

APPLICATION CERTIFICATION FCC Part 15C  
On Behalf of  
Shenzhen HouTian Network Communication Technology Co., Ltd

Wifi Repeater  
Model No.: VRP150

FCC ID: 2AARM-VRP150

Prepared for : Shenzhen HouTian Network Communication Technology  
Co., Ltd  
Address : RM421, Area 3, Block B, Mingyou Ind. Products  
Purchasing Center, Baoan Dist., Shenzhen, China

Prepared by : Accurate Technology Co., Ltd.  
Address : F1, Bldg. A, Changyuan New Material Port, Keyuan Rd.  
Science & Industry Park, Nanshan, Shenzhen, Guangdong  
P.R. China

Tel: (0755) 26503290  
Fax: (0755) 26503396

Report Number : ATE20131606  
Date of Test : July 24-27, 2013  
Date of Report : August 1, 2013

## TABLE OF CONTENTS

Description	Page
Test Report Certification	
<b>1. GENERAL INFORMATION .....</b>	<b>5</b>
1.1. Description of Device (EUT).....	5
1.2. Carrier Frequency of Channels.....	6
1.3. Test Procedure .....	6
1.4. Special Accessory and Auxiliary Equipment .....	6
1.5. Description of Test Facility .....	7
1.6. Measurement Uncertainty.....	7
<b>2. MEASURING DEVICE AND TEST EQUIPMENT .....</b>	<b>8</b>
<b>3. OPERATION OF EUT DURING TESTING .....</b>	<b>9</b>
3.1. Operating Mode.....	9
3.2. Configuration and peripherals .....	9
<b>4. TEST PROCEDURES AND RESULTS .....</b>	<b>10</b>
<b>5. 6DB BANDWIDTH MEASUREMENT.....</b>	<b>11</b>
5.1. Block Diagram of Test Setup.....	11
5.2. The Requirement For Section 15.247(a)(2).....	11
5.3. EUT Configuration on Measurement .....	11
5.4. Operating Condition of EUT .....	11
5.5. Test Procedure .....	12
5.6. Test Result .....	12
<b>6. MAXIMUM PEAK OUTPUT POWER .....</b>	<b>26</b>
6.1. Block Diagram of Test Setup.....	26
6.2. The Requirement For Section 15.247(b)(3).....	26
6.3. EUT Configuration on Measurement .....	26
6.4. Operating Condition of EUT .....	26
6.5. Test Procedure .....	27
6.6. Test Result .....	28
<b>7. POWER SPECTRAL DENSITY MEASUREMENT.....</b>	<b>41</b>
7.1. Block Diagram of Test Setup.....	41
7.2. The Requirement For Section 15.247(e).....	41
7.3. EUT Configuration on Measurement .....	41
7.4. Operating Condition of EUT .....	41
7.5. Test Procedure .....	42
7.6. Test Result .....	43
<b>8. BAND EDGE COMPLIANCE TEST .....</b>	<b>56</b>
8.1. Block Diagram of Test Setup.....	56
8.2. The Requirement For Section 15.247(d) .....	56
8.3. EUT Configuration on Measurement .....	56
8.4. Operating Condition of EUT .....	57
8.5. Test Procedure .....	57
8.6. Test Result .....	58
<b>9. RADIATED SPURIOUS EMISSION TEST .....</b>	<b>91</b>
9.1. Block Diagram of Test Setup.....	91
9.2. The Limit For Section 15.247(d) .....	92
9.3. Restricted bands of operation .....	92

- 9.4. Configuration of EUT on Measurement .....93
- 9.5. Operating Condition of EUT .....93
- 9.6. Test Procedure .....93
- 9.7. The Field Strength of Radiation Emission Measurement Results .....94
- 10. CONDUCTED SPURIOUS EMISSION COMPLIANCE TEST ..... 178**
  - 10.1. Block Diagram of Test Setup..... 178
  - 10.2. The Requirement For Section 15.247(d) ..... 178
  - 10.3. EUT Configuration on Measurement ..... 178
  - 10.4. Operating Condition of EUT ..... 179
  - 10.5. Test Procedure ..... 179
  - 10.6. Test Result ..... 179
- 11. AC POWER LINE CONDUCTED EMISSION FOR FCC PART 15 SECTION 15.207(A) 192**
  - 11.1. Block Diagram of Test Setup..... 192
  - 11.2. The Emission Limit ..... 192
  - 11.3. Configuration of EUT on Measurement ..... 193
  - 11.4. Operating Condition of EUT ..... 193
  - 11.5. Test Procedure ..... 193
  - 11.6. Power Line Conducted Emission Measurement Results ..... 194
- 12. ANTENNA REQUIREMENT..... 197**
  - 12.1. The Requirement ..... 197
  - 12.2. Antenna Construction ..... 197

## Test Report Certification

Applicant : Shenzhen HouTian Network Communication Technology Co., Ltd  
Manufacturer : Shenzhen HouTian Network Communication Technology Co., Ltd  
EUT Description : Wifi Repeater  
(A) MODEL NO.: VRP150  
(B) SERIAL NO.: N/A  
(C) POWER SUPPLY: DC 5V (Power by PC)

Measurement Procedure Used:

### **FCC Rules and Regulations Part 15 Subpart C Section 15.247 ANSI C63.4-2009**

The EUT was tested according to 558074 D01 DTS Meas Guidance v03r01

The device described above is tested by ACCURATE TECHNOLOGY CO. LTD to determine the maximum emission levels emanating from the device. The maximum emission levels are compared to the FCC Part 15 Subpart C Section 15.247 limits. The measurement results are contained in this test report and ACCURATE TECHNOLOGY CO. LTD is assumed full responsibility for the accuracy and completeness of these measurements. Also, this report shows that the Equipment Under Test (EUT) is to be technically compliant with the FCC requirements.

This report applies to above tested sample only. This report shall not be reproduced in part without written approval of Accurate Technology Co., Ltd.

Date of Test : July 24-27, 2013

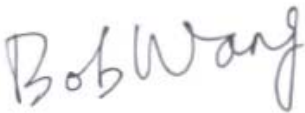
Prepared by :   
(Engineer)

Approved & Authorized Signer :   
(Manager)

# 1. GENERAL INFORMATION

## 1.1. Description of Device (EUT)

EUT	:	Wifi Repeater
Model Number	:	VRP150
Frequency Range	:	802.11b/g/n(20MHz): 2412-2462MHz 802.11n(40MHz): 2422-2452MHz
Number of Channels	:	802.11b/g/n (20MHz):11 802.11n (40MHz): 7
Trade Name	:	VONETS
Antenna Gain	:	2dBi
Power Supply	:	DC 5V (Power by PC)
Data Rate	:	802.11b: 11, 5.5, 2, 1 Mbps 802.11g: 54, 48, 36, 24, 18, 12, 9, 6 Mbps 802.11n: up to 150Mbps
Applicant	:	Shenzhen HouTian Network Communication Technology Co., Ltd
Address	:	RM421, Area 3, Block B, Mingyou Ind. Products Purchasing Center, Baoan Dist., Shenzhen, China
Manufacturer	:	Shenzhen HouTian Network Communication Technology Co., Ltd
Address	:	RM421, Area 3, Block B, Mingyou Ind. Products Purchasing Center, Baoan Dist., Shenzhen, China
Date of sample received	:	July 25, 2013
Date of Test	:	July 24-27, 2013

## 1.2. Carrier Frequency of Channels

802.11b, 802.11g, 802.11n (20MHz)

Channel	Frequency(MHz)	Channel	Frequency(MHz)
01	2412	07	2442
02	2417	08	2447
03	2422	09	2452
04	2427	10	2457
05	2432	11	2462
06	2437	---	---

802.11n (40MHz)

Channel	Frequency(MHz)	Channel	Frequency(MHz)
---	---	07	2442
---	---	08	2447
03	2422	09	2452
04	2427	---	---
05	2432	---	---
06	2437	---	---

## 1.3. Test Procedure

The EUT was tested according to 558074 D01 DTS Meas Guidance v03r01

## 1.4. Special Accessory and Auxiliary Equipment

n.a.

### 1.5. Description of Test Facility

EMC Lab : Accredited by TUV Rheinland Shenzhen

Listed by FCC  
The Registration Number is 752051

Listed by Industry Canada  
The Registration Number is 5077A-2

Accredited by China National Accreditation Committee  
for Laboratories  
The Certificate Registration Number is L3193

Name of Firm : Accurate Technology Co., Ltd.  
Site Location : F1, Bldg. A, Changyuan New Material Port, Keyuan Rd.  
Science & Industry Park, Nanshan, Shenzhen, Guangdong  
P.R. China

### 1.6. Measurement Uncertainty

Conducted Emission Expanded Uncertainty = 2.23dB, k=2

Radiated emission expanded uncertainty = 3.08dB, k=2  
(9kHz-30MHz)

Radiated emission expanded uncertainty = 4.42dB, k=2  
(30MHz-1000MHz)

Radiated emission expanded uncertainty = 4.06dB, k=2  
(Above 1GHz)

## 2. MEASURING DEVICE AND TEST EQUIPMENT

**Table 1: List of Test and Measurement Equipment**

Kind of equipment	Manufacturer	Type	S/N	Calibrated dates	Calibrated until
EMI Test Receiver	Rohde&Schwarz	ESCS30	100307	Jan. 12, 2013	Jan. 11, 2014
EMI Test Receiver	Rohde&Schwarz	ESPI3	101526/003	Jan. 12, 2013	Jan. 11, 2014
Spectrum Analyzer	Agilent	E7405A	MY45115511	Jan. 12, 2013	Jan. 11, 2014
Pre-Amplifier	Rohde&Schwarz	CBLU118354 0-01	3791	Jan. 12, 2013	Jan. 11, 2014
Loop Antenna	Schwarzbeck	FMZB1516	1516131	Feb. 6, 2013	Feb. 5, 2014
Bilog Antenna	Schwarzbeck	VULB9163	9163-323	Feb. 6, 2013	Feb. 5, 2014
Horn Antenna	Schwarzbeck	BBHA9120D	9120D-655	Feb. 6, 2013	Feb. 5, 2014
Horn Antenna	Schwarzbeck	BBHA9170	9170-359	Feb. 6, 2013	Feb. 5, 2014
LISN	Rohde&Schwarz	ESH3-Z5	100305	Jan. 12, 2013	Jan. 11, 2014
LISN	Schwarzbeck	NSLK8126	8126431	Jan. 12, 2013	Jan. 11, 2014
Highpass Filter	Wainwright Instruments	WHKX3.6/18 G-10SS	N/A	Jan. 12, 2013	Jan. 11, 2014
Band Reject Filter	Wainwright Instruments	WRCG2400/2 485-2375/2510 -60/11SS	N/A	Jan. 12, 2013	Jan. 11, 2014



### 3. OPERATION OF EUT DURING TESTING

#### 3.1. Operating Mode

The mode is used: **1.802.11b Transmitting mode**

Low Channel: 2412MHz

Middle Channel: 2437MHz

High Channel: 2462MHz

**2.802.11g Transmitting mode**

Low Channel: 2412MHz

Middle Channel: 2437MHz

High Channel: 2462MHz

**3.802.11n (20MHz) Transmitting mode**

Low Channel: 2412MHz

Middle Channel: 2437MHz

High Channel: 2462MHz

**4.802.11n (40MHz) Transmitting mode**

Low Channel: 2422MHz

Middle Channel: 2437MHz

High Channel: 2452MHz

#### 3.2. Configuration and peripherals

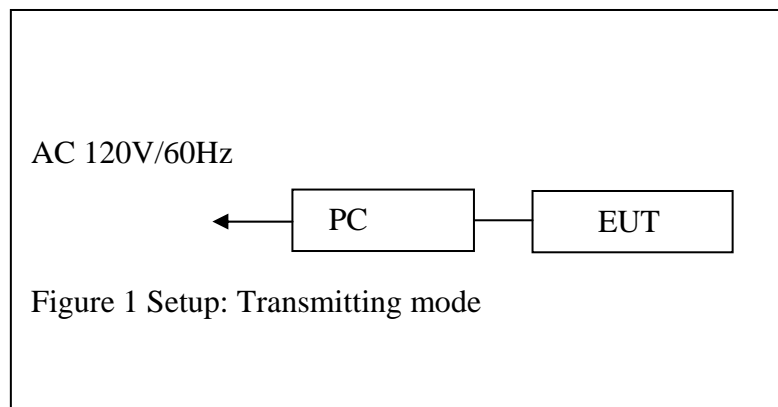

#### 4. TEST PROCEDURES AND RESULTS

<b>FCC Rules</b>	<b>Description of Test</b>	<b>Result</b>
Section 15.247(a)(2)	6dB Bandwidth Test	Compliant
Section 15.247(e)	Power Spectral Density Test	Compliant
Section 15.247(b)(3)	Maximum Peak Output Power Test	Compliant
Section 15.247(d)	Band Edge Compliance Test	Compliant
Section 15.247(d) Section 15.209	Radiated Spurious Emission Test	Compliant
Section 15.247(d)	Conducted Spurious Emission Test	Compliant
Section 15.207	AC Power Line Conducted Emission Test	Compliant
Section 15.203	Antenna Requirement	Compliant

## 5. 6DB BANDWIDTH MEASUREMENT

### 5.1. Block Diagram of Test Setup

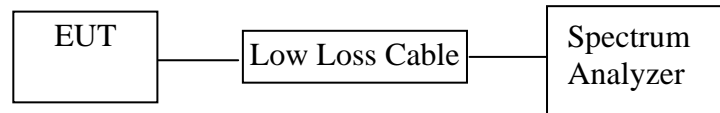

(EUT: Wifi Repeater)

### 5.2. The Requirement For Section 15.247(a)(2)

Section 15.247(a)(2): Systems using digital modulation techniques may operate in the 902-928MHz, 2400-2483.5MHz, and 5725-5850MHz bands. The minimum 6 dB bandwidth shall be at least 500 kHz.

### 5.3. EUT Configuration on Measurement

The following equipment are installed on the emission measurement to meet the commission requirements and operating regulations in a manner which tends to maximize its emission characteristics in normal application.

#### 5.3.1. Wifi Repeater (EUT)

Model Number	:	VRP150
Serial Number	:	N/A
Manufacturer	:	Shenzhen HouTian Network Communication Technology Co., Ltd

### 5.4. Operating Condition of EUT

5.4.1. Setup the EUT and simulator as shown as Section 5.1.

5.4.2. Turn on the power of all equipment.

5.4.3. Let the EUT work in TX modes measure it. The transmit frequency are 2412-2462 and 2422-2452MHz. We select 2412MHz, 2437MHz, 2462MHz and 2422MHz, 2437MHz, 2452MHz TX frequency to transmit.

### 5.5. Test Procedure

1. Set resolution bandwidth (RBW) = 100 kHz.
2. Set the video bandwidth (VBW)  $\geq 3 \times$  RBW.
3. Detector = Peak.
4. Trace mode = max hold.
5. Sweep = auto couple.
6. Allow the trace to stabilize.
7. Measure the maximum width of the emission that is constrained by the frequencies associated with the two outermost amplitude points (upper and lower) that are attenuated by 6 dB relative to the maximum level measured in the fundamental emission.

### 5.6. Test Result

**PASS.**

Date of Test:	<u>July 25, 2013</u>	Temperature:	<u>25°C</u>
EUT:	<u>Wifi Repeater</u>	Humidity:	<u>50%</u>
Model No.:	<u>VRP150</u>	Power Supply:	<u>AC 120V/60HZ</u>
Test Mode:	<u>TX</u>	Test Engineer:	<u>Star</u>

The test was performed with 802.11b

Channel	Frequency (MHz)	6dB Bandwidth (MHz)	Limit (MHz)
Low	2412	10.12	> 0.5MHz
Middle	2437	10.12	> 0.5MHz
High	2462	10.12	> 0.5MHz

The test was performed with 802.11g

Channel	Frequency (MHz)	6dB Bandwidth (MHz)	Limit (MHz)
Low	2412	16.40	> 0.5MHz
Middle	2437	16.40	> 0.5MHz
High	2462	16.40	> 0.5MHz

The test was performed with 802.11n (Bandwidth: 20 MHz)			
Channel	Frequency (MHz)	6dB Bandwidth (MHz)	Limit (MHz)
Low	2412	17.60	> 0.5MHz
Middle	2437	17.60	> 0.5MHz
High	2462	17.60	> 0.5MHz

The test was performed with 802.11n (Bandwidth: 40 MHz)			
Channel	Frequency (MHz)	6dB Bandwidth (MHz)	Limit (MHz)
Low	2422	35.28	> 0.5MHz
Middle	2437	35.36	> 0.5MHz
High	2452	35.28	> 0.5MHz

The spectrum analyzer plots are attached as below.

802.11b Channel Low 2412MHz

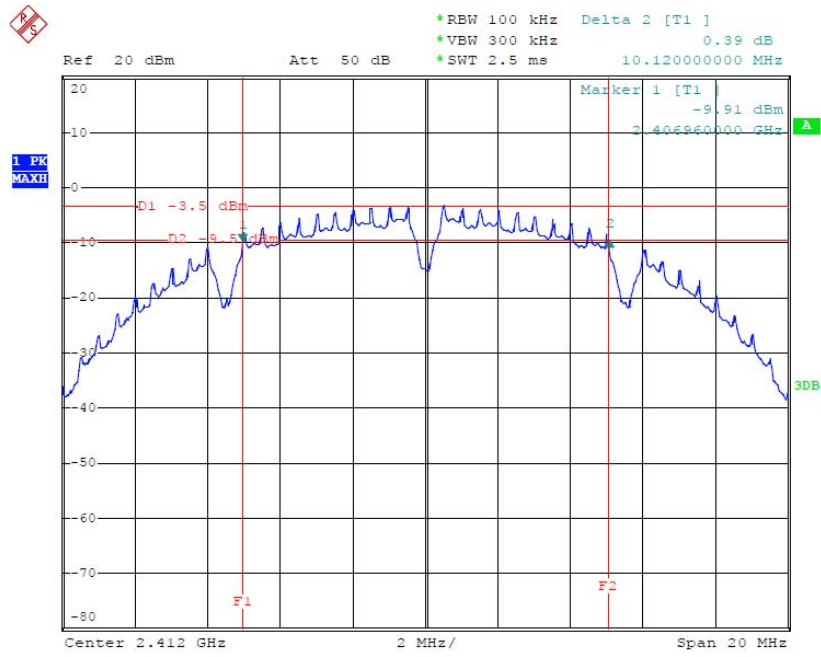

802.11b Channel Middle 2437MHz

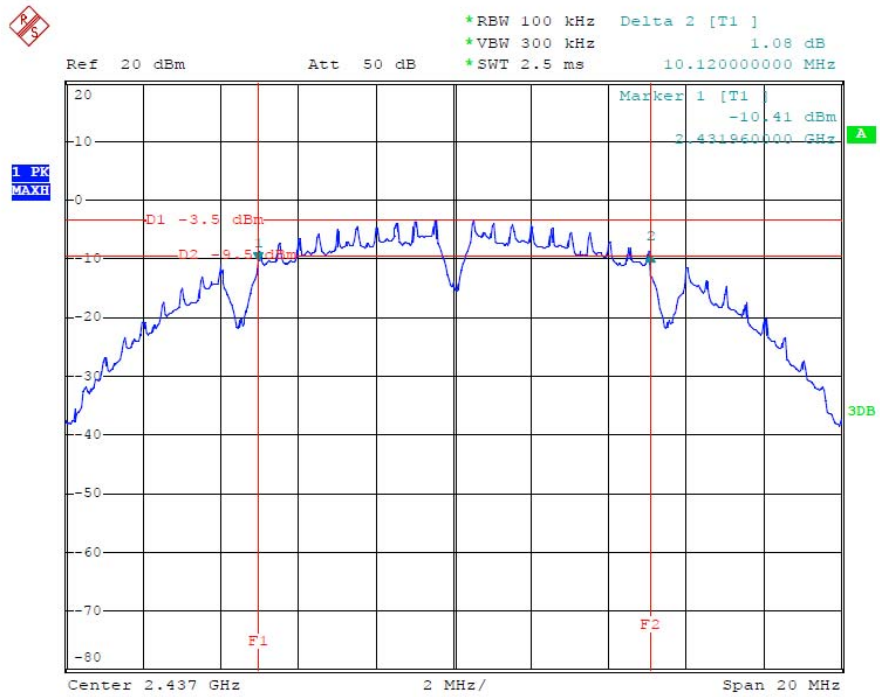

### 802.11b Channel High 2462MHz

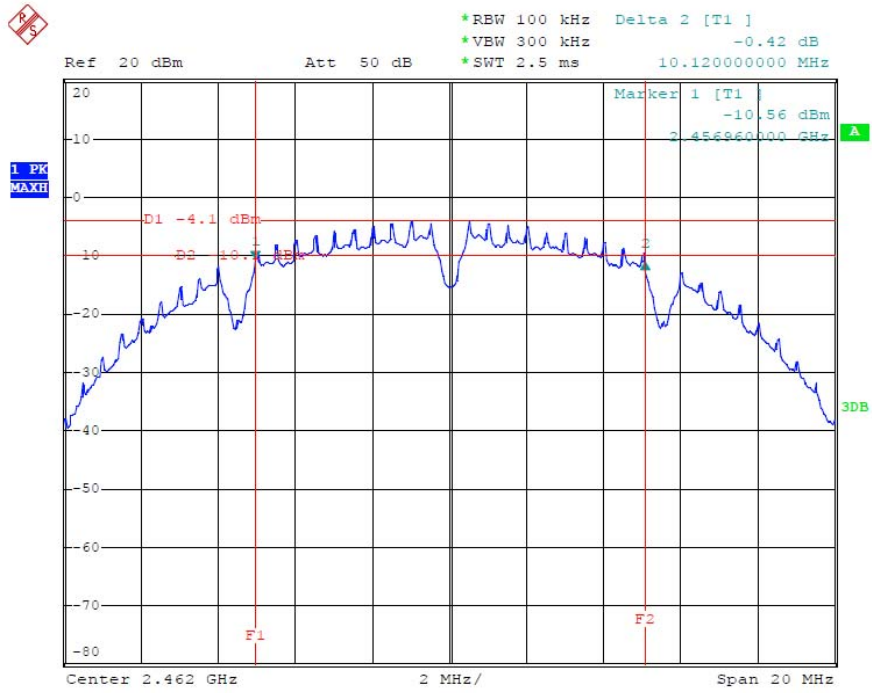



### 802.11g Channel Low 2412MHz

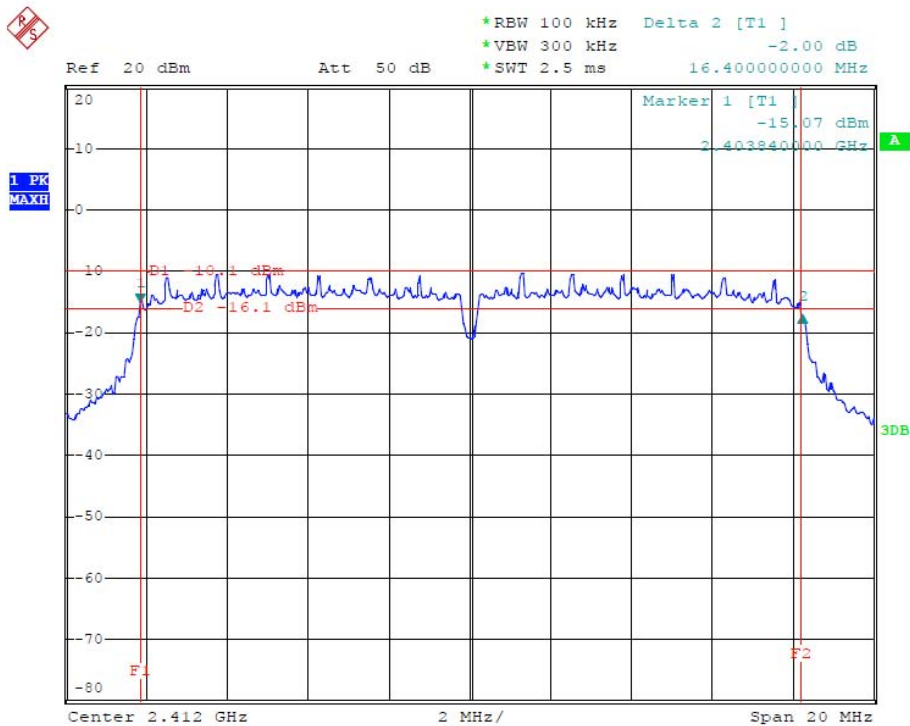

### 802.11g Channel Middle 2437MHz

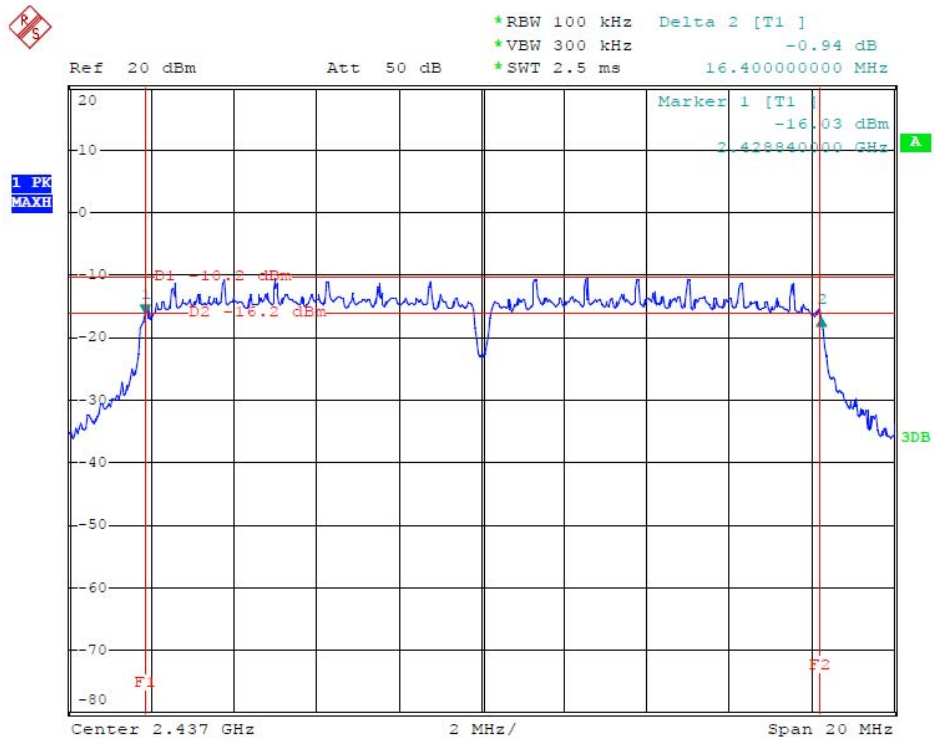

### 802.11g Channel High 2462MHz

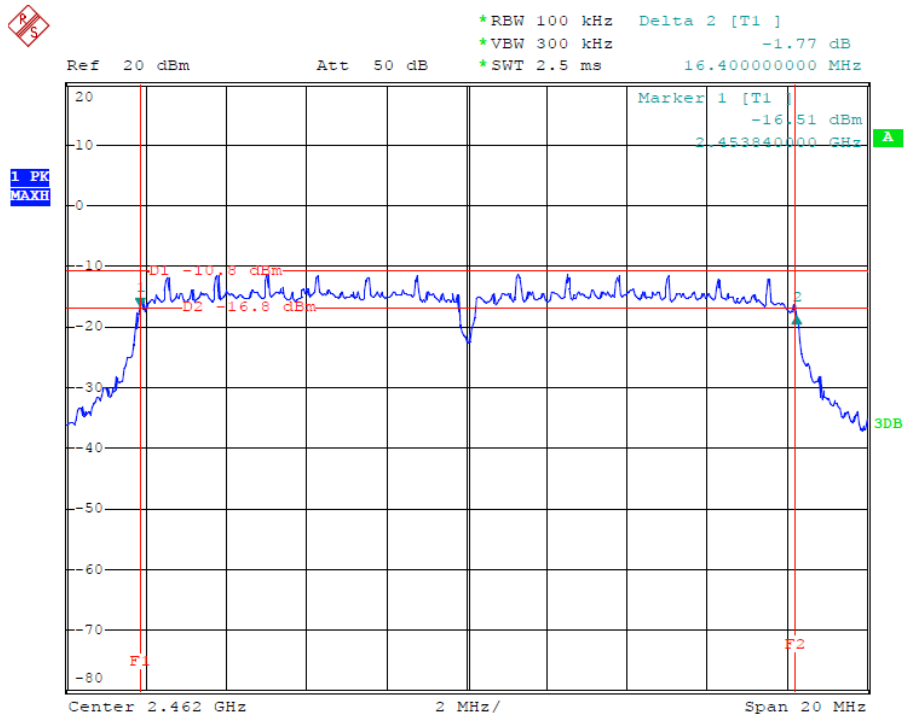

802.11n Channel Low 2412MHz (20MHz)

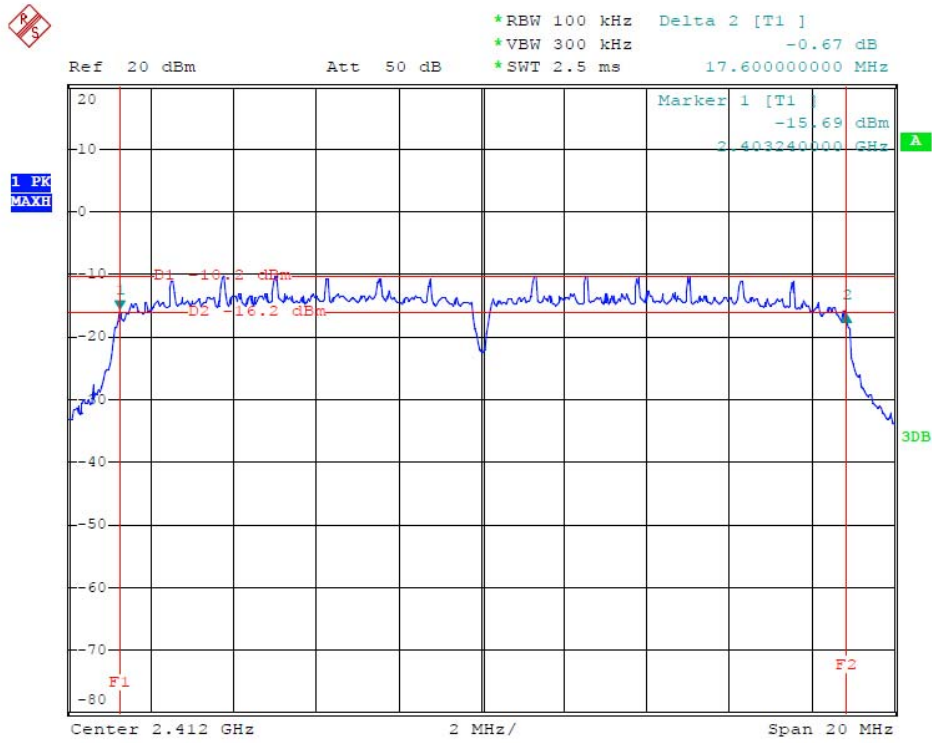

802.11n Channel Middle 2437MHz(20MHz)

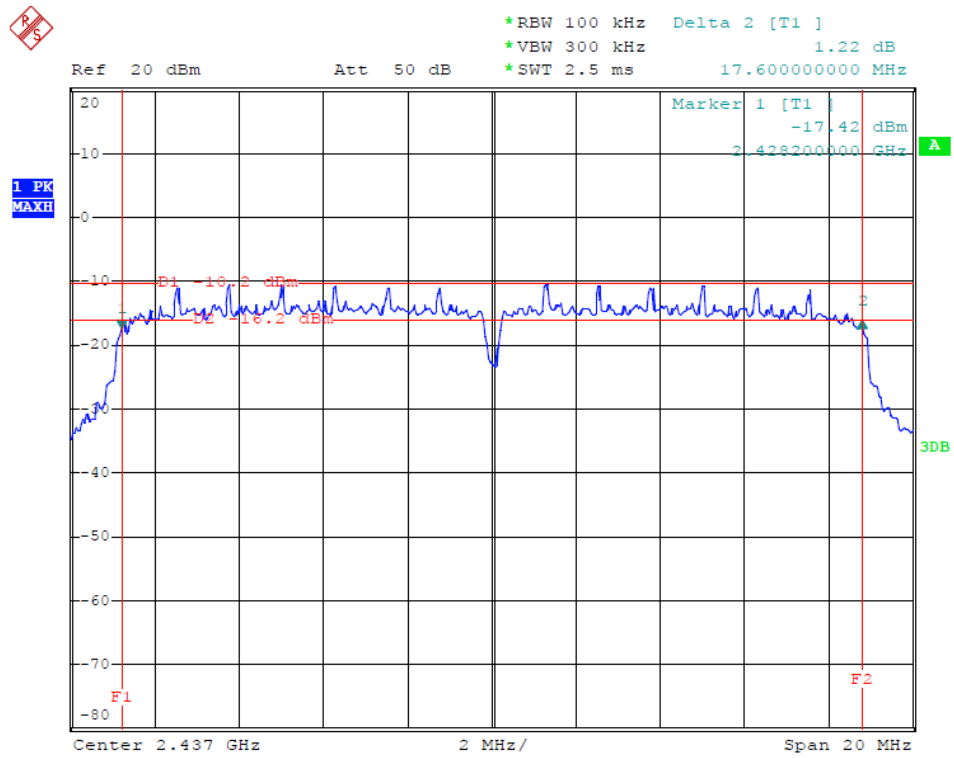

802.11n Channel High 2462MHz(20MHz)

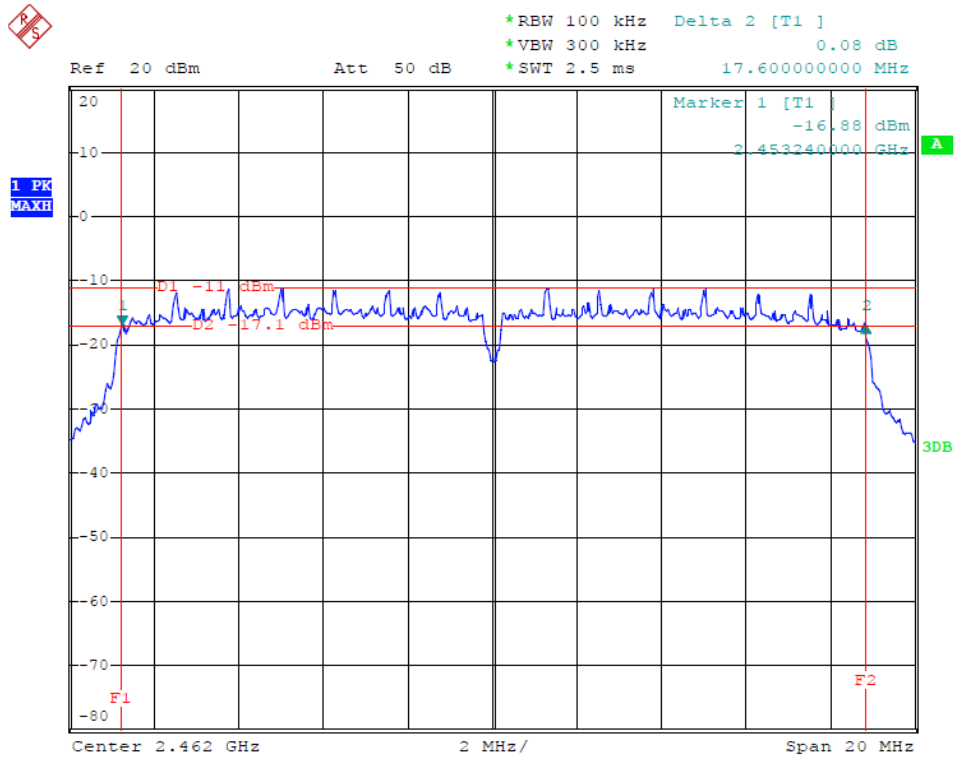

802.11n Channel Low 2422MHz (40MHz)

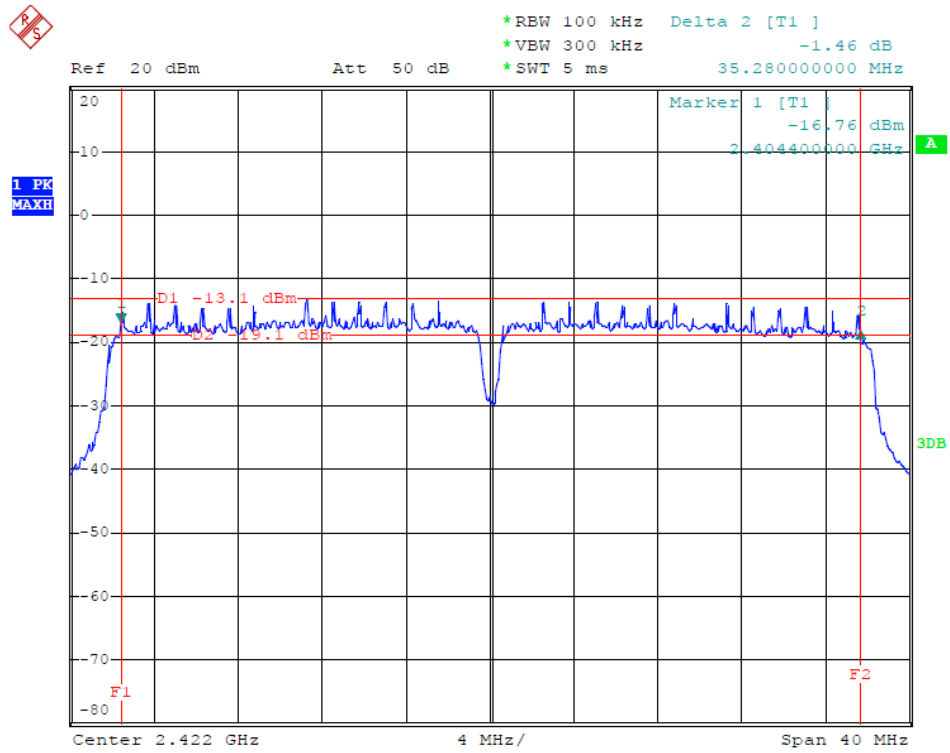

802.11n Channel Middle 2437MHz(40MHz)

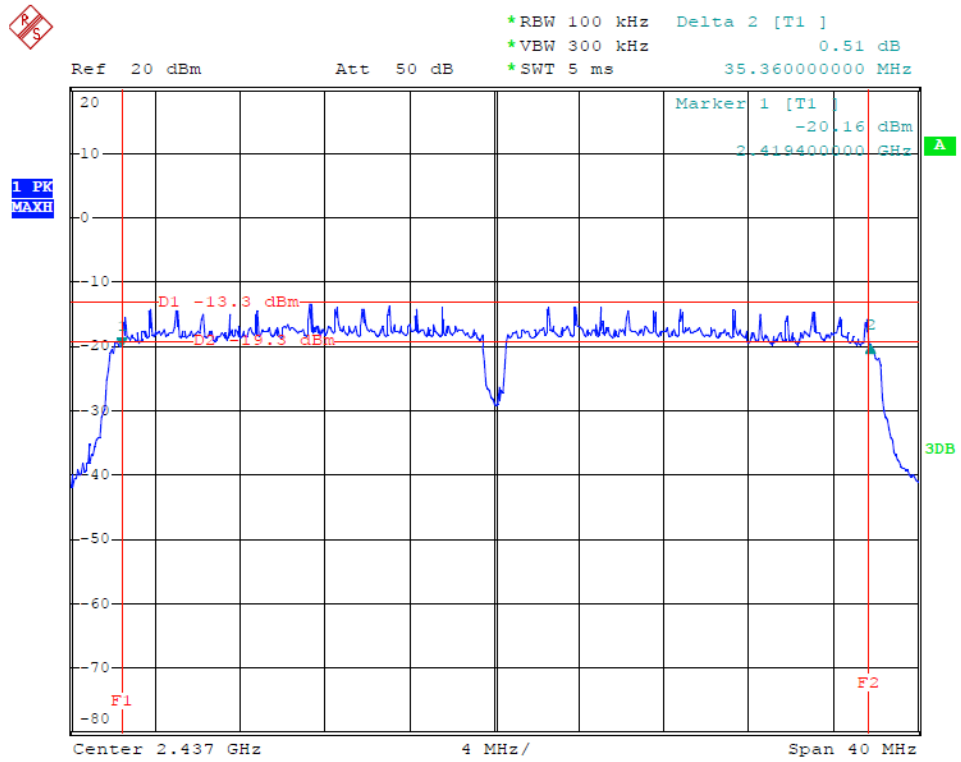



802.11n Channel High 2452MHz(40MHz)

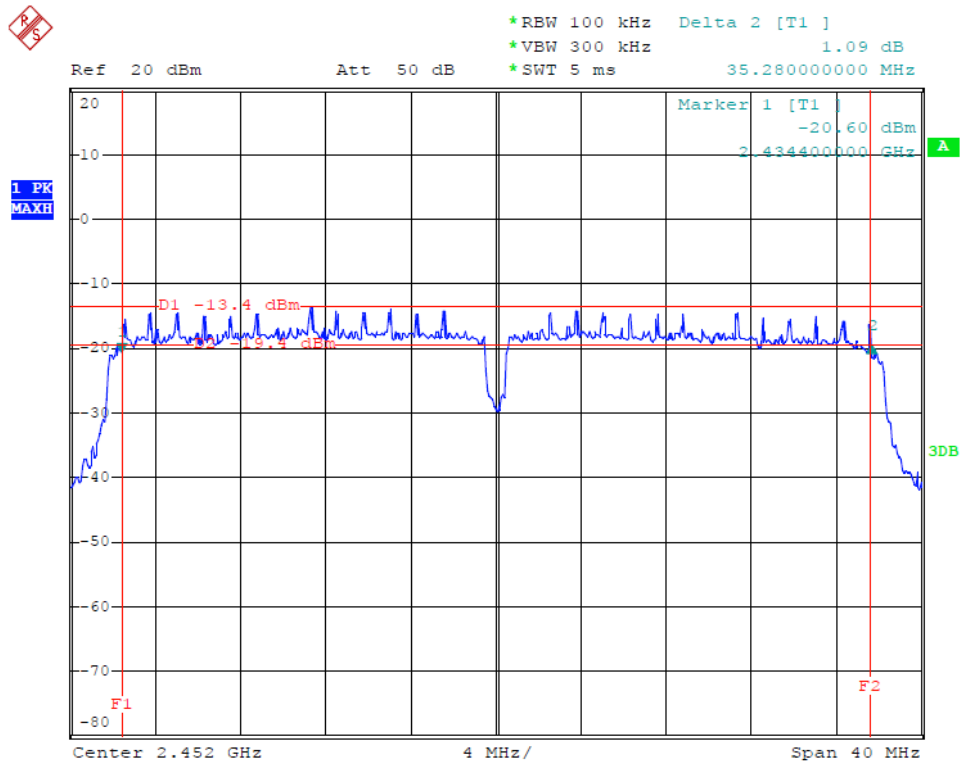

## 6. MAXIMUM PEAK OUTPUT POWER

### 6.1. Block Diagram of Test Setup

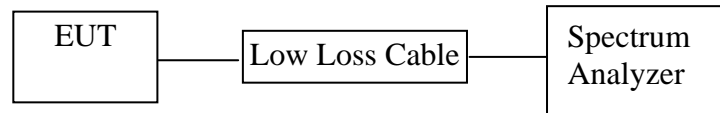

(EUT: Wifi Repeater)

### 6.2. The Requirement For Section 15.247(b)(3)

Section 15.247(b)(3): For systems using digital modulation in the 902-928MHz, 2400-2483.5MHz, and 5725-5850MHz bands: 1 Watt.

### 6.3. EUT Configuration on Measurement

The following equipment are installed on the emission Measurement to meet the commission requirements and operating regulations in a manner which tends to maximize its emission characteristics in normal application.

#### 6.3.1. Wifi Repeater (EUT)

Model Number	:	VRP150
Serial Number	:	N/A
Manufacturer	:	Shenzhen HouTian Network Communication Technology Co., Ltd

### 6.4. Operating Condition of EUT

6.4.1. Setup the EUT and simulator as shown as Section 6.1.

6.4.2. Turn on the power of all equipment.

6.4.3. Let the EUT work in TX modes measure it. The transmit frequency are 2412-2462 and 2422-2452MHz. We select 2412MHz, 2437MHz, 2462MHz and 2422MHz, 2437MHz, 2452MHz TX frequency to transmit.

## 6.5. Test Procedure

6.5.1. The EUT was tested according to Section 9.1.2 of the 558074 D01 DTS Meas Guidance v03r01

6.5.2. The transmitter output was connected to the spectrum analyzer through a low loss cable.

6.5.3. a) Set the RBW = 1 MHz.

b) Set the VBW  $\geq$  3 RBW

c) Set the span  $\geq$  1.5 x DTS bandwidth.

d) Detector = peak.

e) Sweep time = auto couple.

f) Trace mode = max hold.

g) Allow trace to fully stabilize.

h) Use the instrument's band/channel power measurement function with the band limits set equal to the DTS bandwidth edges (for some instruments, this may require a manual override to select peak detector). If the instrument does not have a band power function, sum the spectrum levels (in linear power units) at intervals equal to the RBW extending across the DTS bandwidth.

6.5.4. Measurement the maximum peak output power.

## 6.6. Test Result

**PASS.**

Date of Test:	July 25, 2013	Temperature:	25°C
EUT:	Wifi Repeater	Humidity:	50%
Model No.:	VRP150	Power Supply:	AC 120V/60HZ
Test Mode:	TX	Test Engineer:	Star

The test was performed with 802.11b

Channel	Frequency (MHz)	Peak Output Power (dBm)	Peak Output Power (mW)	Limits dBm / W
Low	2412	8.80	7.59	30 dBm / 1 W
Middle	2437	8.44	6.98	30 dBm / 1 W
High	2462	7.72	5.92	30 dBm / 1 W

The test was performed with 802.11g

Channel	Frequency (MHz)	Peak Output Power (dBm)	Peak Output Power (mW)	Limits dBm / W
Low	2412	9.54	8.99	30 dBm / 1 W
Middle	2437	9.16	8.29	30 dBm / 1 W
High	2462	8.53	7.13	30 dBm / 1 W

The test was performed with 802.11n (20MHz)

Channel	Frequency (MHz)	Peak Output Power (dBm)	Peak Output Power (mW)	Limits dBm / W
Low	2412	9.50	8.91	30 dBm / 1 W
Middle	2437	9.18	8.28	30 dBm / 1 W
High	2462	8.81	7.60	30 dBm / 1 W

The test was performed with 802.11n (40MHz)

Channel	Frequency (MHz)	Peak Output Power (dBm)	Peak Output Power (mW)	Limits dBm / W
Low	2422	9.07	8.07	30 dBm / 1 W
Middle	2437	8.76	7.52	30 dBm / 1 W
High	2452	8.37	6.87	30 dBm / 1 W

The spectrum analyzer plots are attached as below.

### 802.11b Channel Low 2412MHz

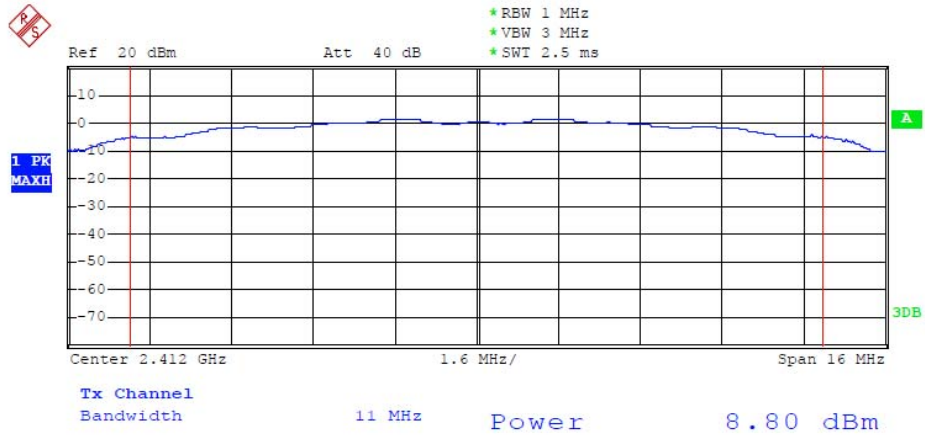

### 802.11b Channel Middle 2437MHz

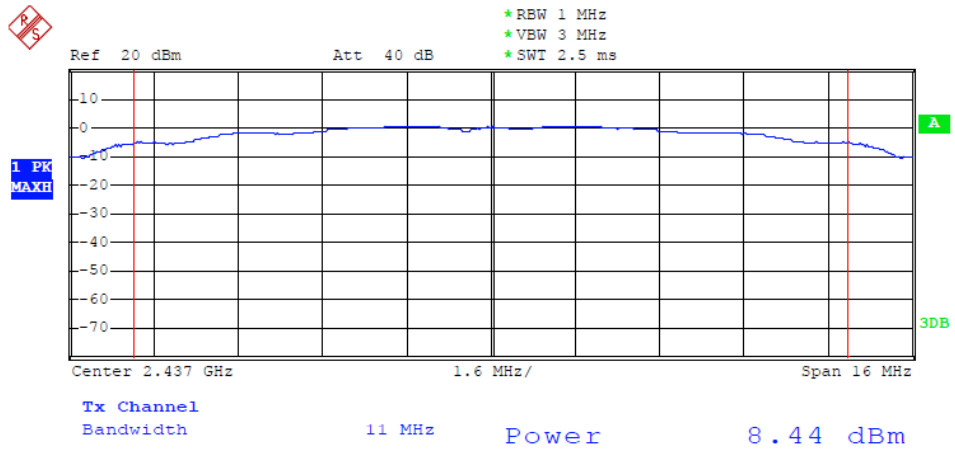

### 802.11b Channel High 2462MHz

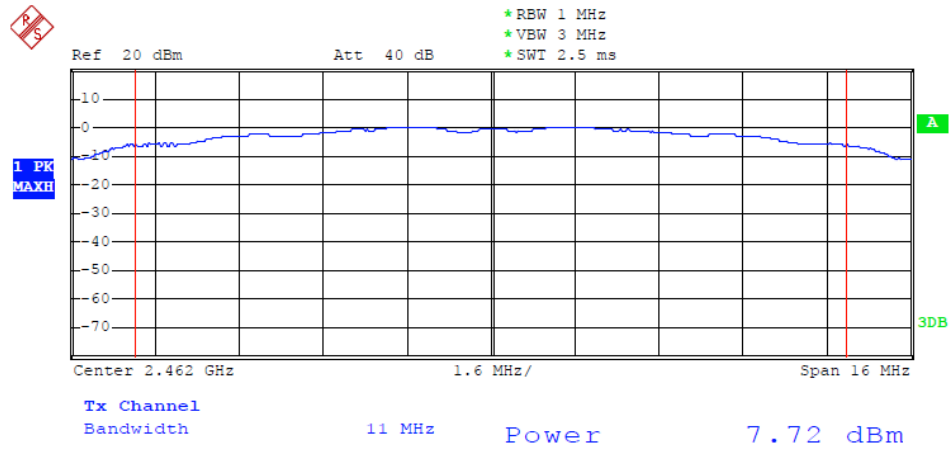

### 802.11g Channel Low 2412MHz

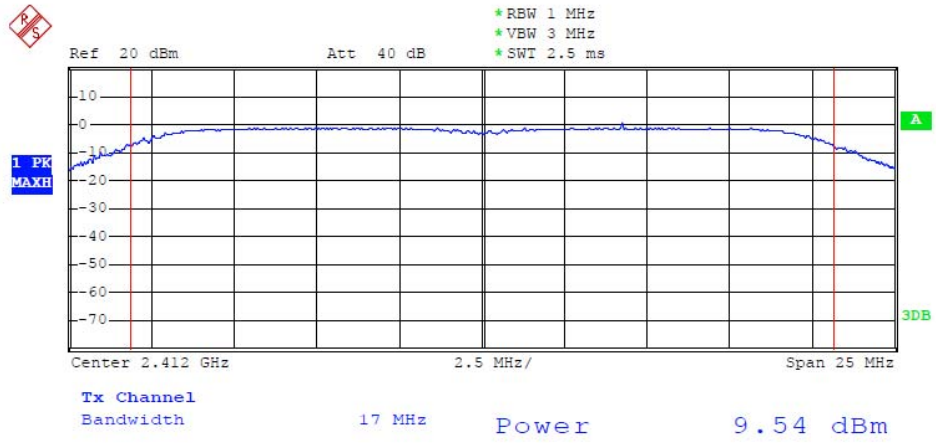



### 802.11g Channel Middle 2437MHz

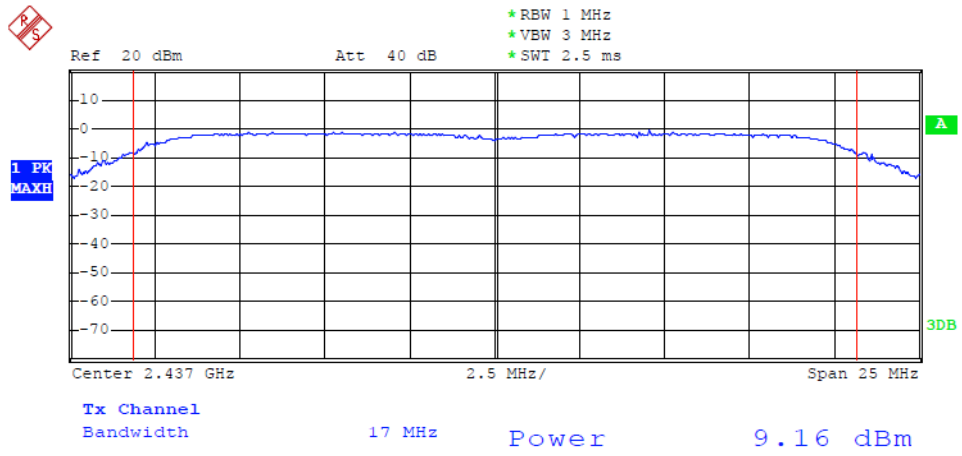

### 802.11g Channel High 2462MHz

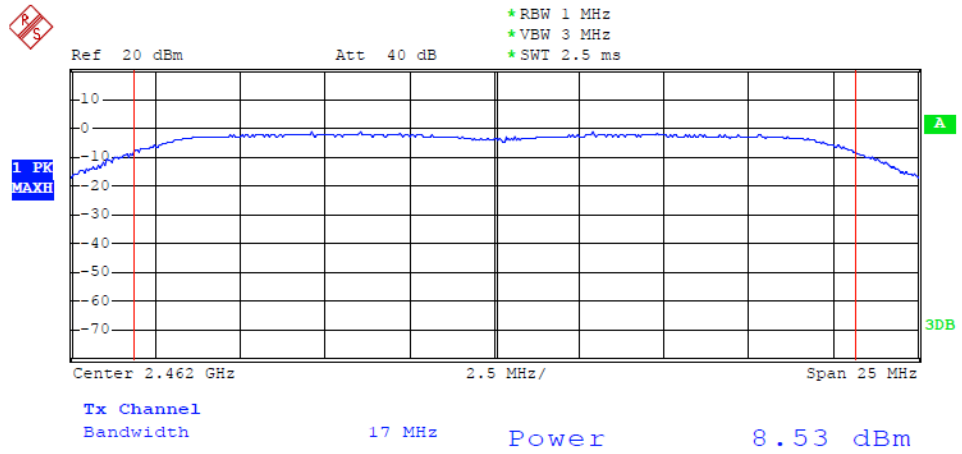

### 802.11n Channel Low 2412MHz (20MHz)

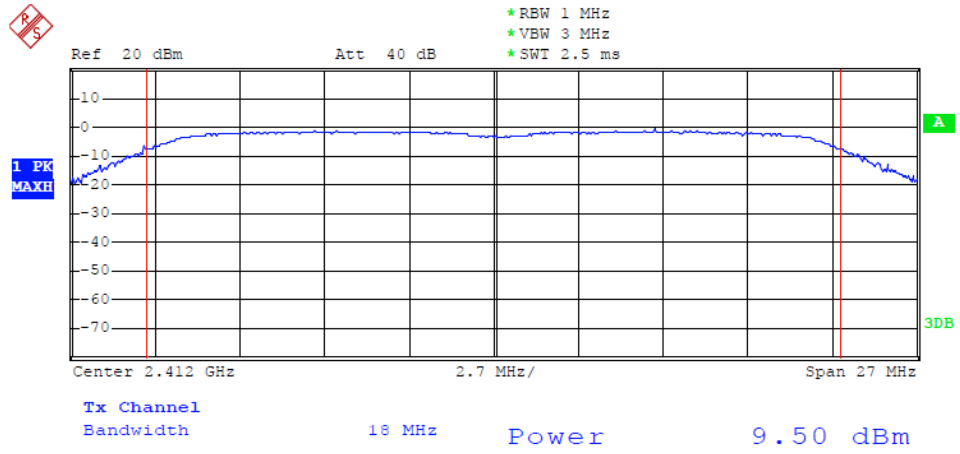

### 802.11n Channel Middle 2437MHz (20MHz)

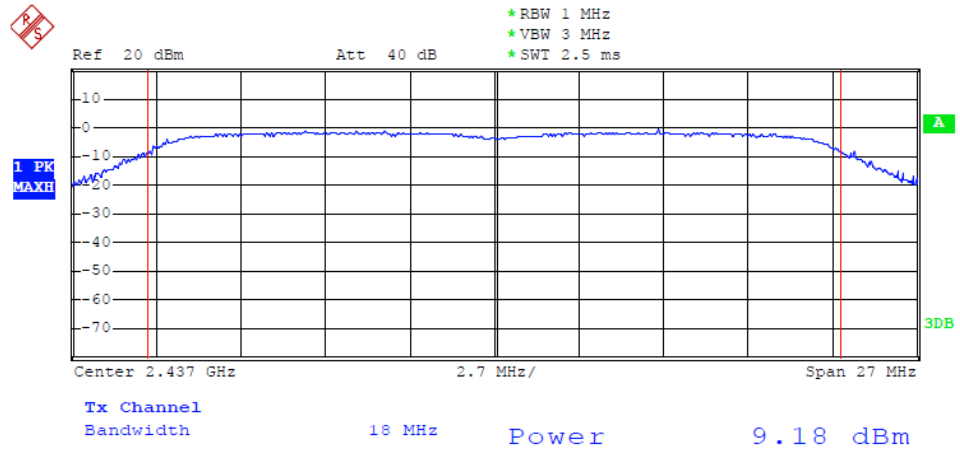

### 802.11n Channel High 2462MHz (20MHz)

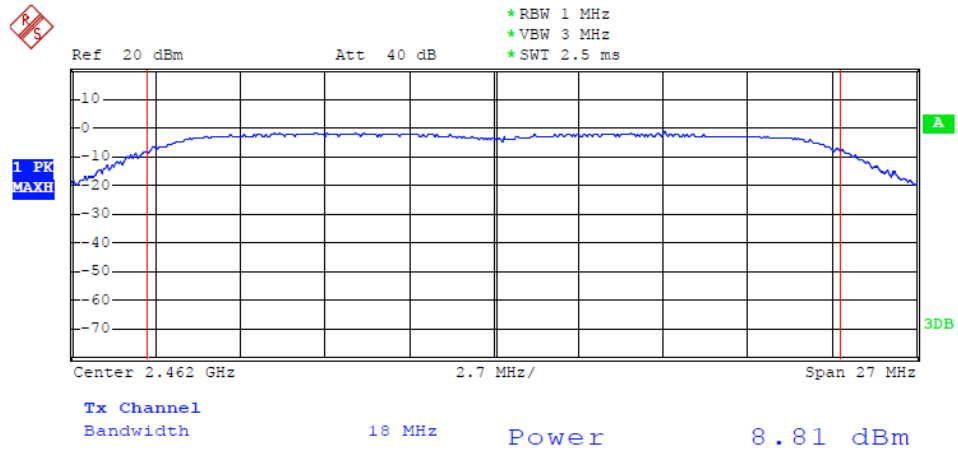

### 802.11n Channel Low 2422MHz (40MHz)

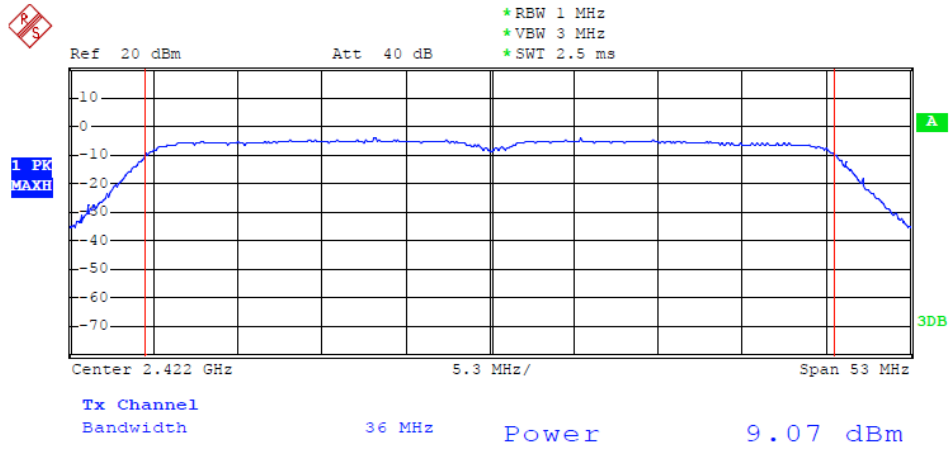

### 802.11n Channel Middle 2437MHz (40MHz)

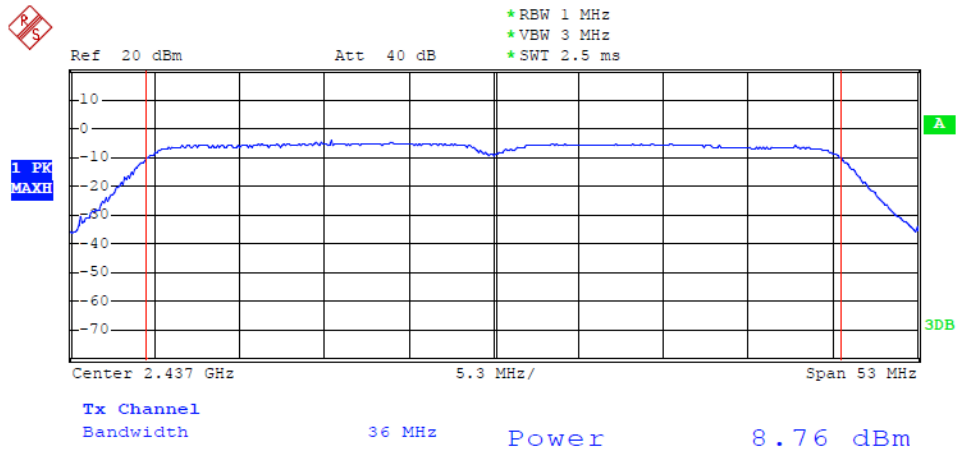

### 802.11n Channel High 2452MHz (40MHz)

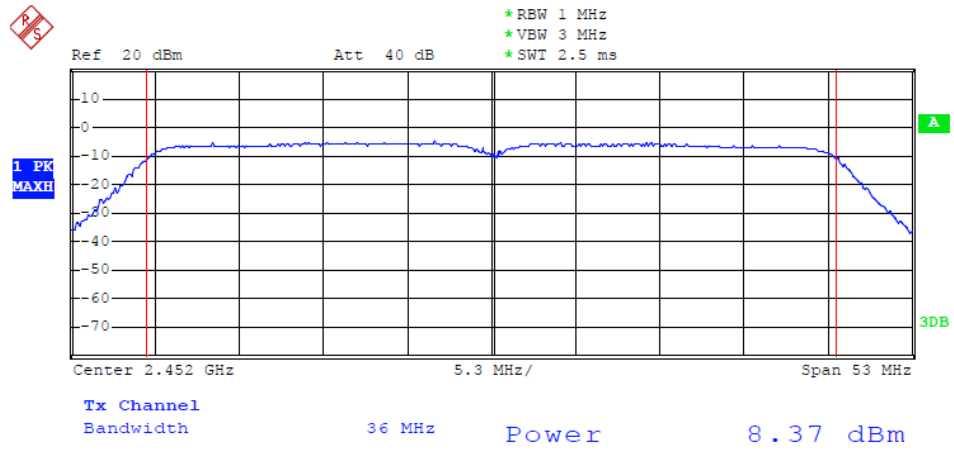



## 7. POWER SPECTRAL DENSITY MEASUREMENT

### 7.1. Block Diagram of Test Setup

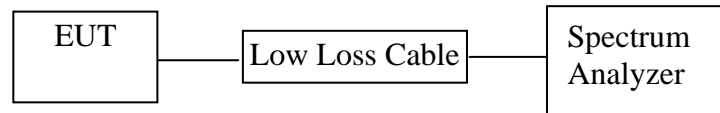

(EUT: Wifi Repeater)

### 7.2. The Requirement For Section 15.247(e)

Section 15.247(e): For digitally modulated systems, the power spectral density conducted from the intentional radiator to the antenna shall not be greater than 8 dBm in any 3 kHz band during any time interval of continuous transmission.

### 7.3. EUT Configuration on Measurement

The following equipment are installed on the emission Measurement to meet the commission requirements and operating regulations in a manner which tends to maximize its emission characteristics in normal application.

#### 7.3.1. Wifi Repeater (EUT)

Model Number	:	VRP150
Serial Number	:	N/A
Manufacturer	:	Shenzhen HouTian Network Communication Technology Co., Ltd

### 7.4. Operating Condition of EUT

7.4.1. Setup the EUT and simulator as shown as Section 7.1.

7.4.2. Turn on the power of all equipment.

7.4.3. Let the EUT work in TX modes measure it. The transmit frequency are 2412-2462 and 2422-2452MHz. We select 2412MHz, 2437MHz, 2462MHz and 2422MHz, 2437MHz, 2452MHz TX frequency to transmit.

## 7.5. Test Procedure

7.5.1. The EUT was tested according to Section 10.2 of the 558074 D01 DTS Meas Guidance v03r01.

7.5.2. The transmitter output was connected to the spectrum analyzer through a low loss cable.

7.5.3. Measurement Procedure PKPSD (peak PSD):

This procedure shall be used if maximum peak conducted output power was used to demonstrate compliance, and is optional if the maximum conducted (average) output power was used to demonstrate compliance.

1. Set analyzer center frequency to DTS channel center frequency.
2. Set the span to 1.5 times the DTS channel bandwidth.
3. Set the RBW  $\geq$  3 kHz.
4. Set the VBW  $\geq$  3 x RBW.
5. Detector = peak.
6. Sweep time = auto couple.
7. Trace mode = max hold.
8. Allow trace to fully stabilize.
9. Use the peak marker function to determine the maximum amplitude level.
10. If measured value exceeds limit, reduce RBW (no less than 3 kHz) and repeat.

7.5.4. Measurement the maximum power spectral density.

## 7.6. Test Result

**PASS.**

Date of Test:	July 25, 2013	Temperature:	25°C
EUT:	Wifi Repeater	Humidity:	50%
Model No.:	VRP150	Power Supply:	AC 120V/60Hz
Test Mode:	TX	Test Engineer:	Star

The test was performed with 802.11b

Channel	Frequency (MHz)	Power Spectral Density (dBm)	Limits (dBm)
Low	2412	-17.98	8 dBm
Middle	2437	-18.97	8 dBm
High	2462	-18.64	8 dBm

The test was performed with 802.11g

Channel	Frequency (MHz)	Power Spectral Density (dBm)	Limits (dBm)
Low	2412	-25.22	8 dBm
Middle	2437	-24.30	8 dBm
High	2462	-24.63	8 dBm

The test was performed with 802.11n (20MHz)

Channel	Frequency (MHz)	Power Spectral Density (dBm)	Limits (dBm)
Low	2412	-23.84	8 dBm
Middle	2437	-24.79	8 dBm
High	2462	-25.42	8 dBm

The test was performed with 802.11n (40MHz)

Channel	Frequency (MHz)	Power Spectral Density (dBm)	Limits (dBm)
Low	2422	-28.36	8 dBm
Middle	2437	-27.20	8 dBm
High	2452	-28.69	8 dBm

The spectrum analyzer plots are attached as below.

### 802.11b Channel Low 2412MHz

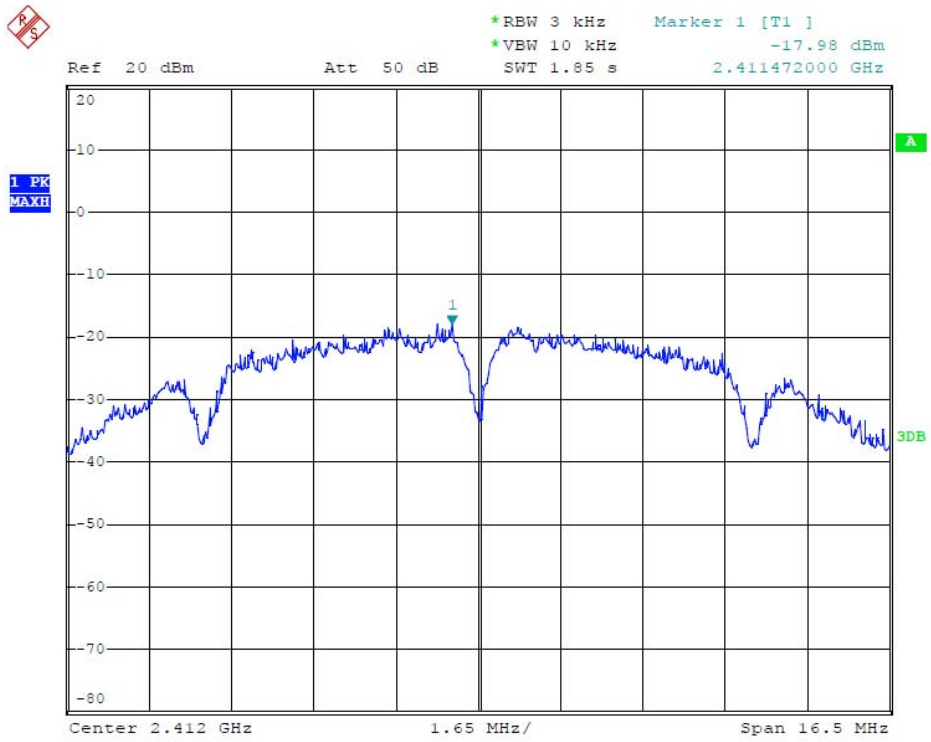

### 802.11b Channel Middle 2437MHz

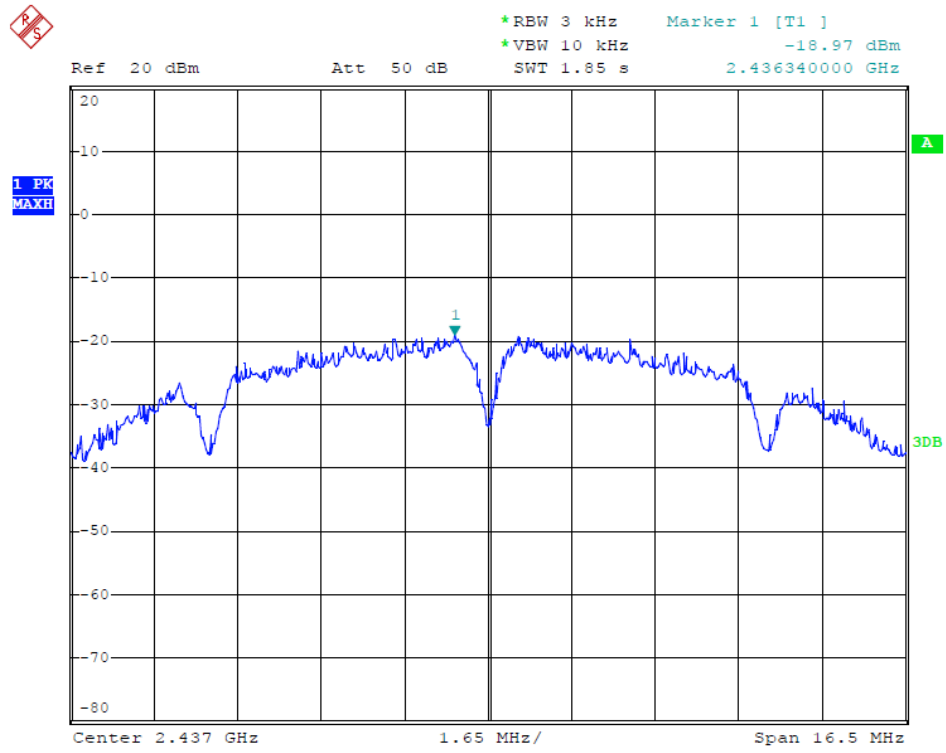

### 802.11b Channel High 2462MHz

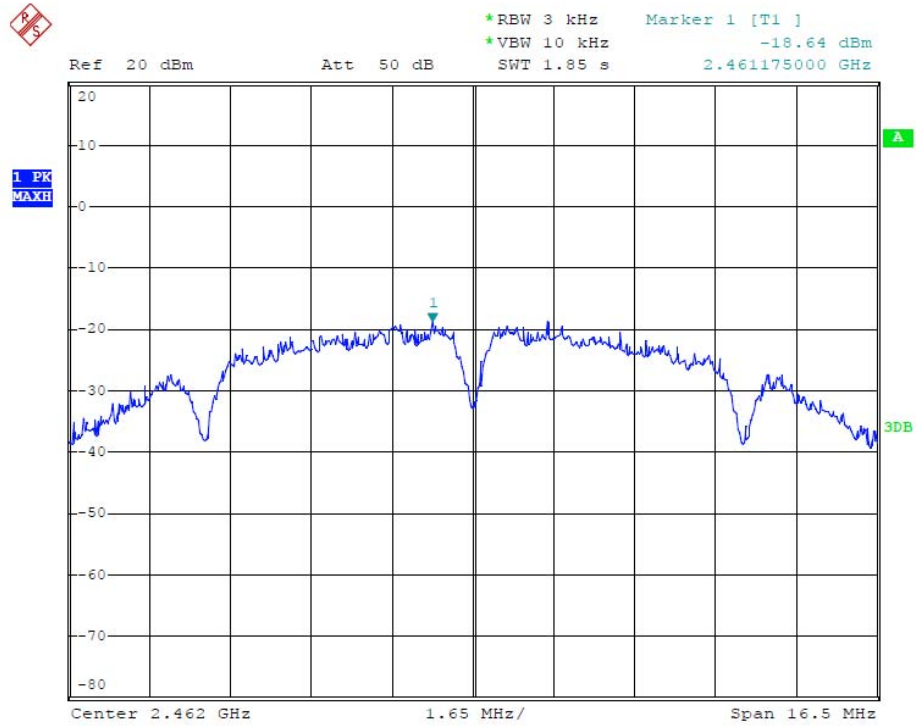

### 802.11g Channel Low 2412MHz

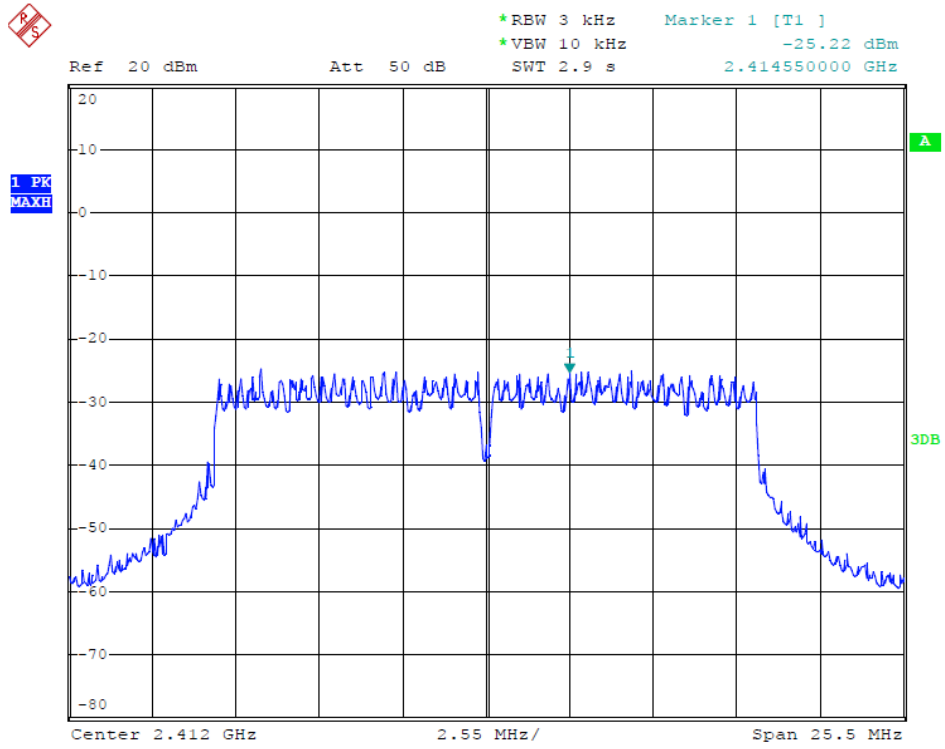

### 802.11g Channel Middle 2437MHz

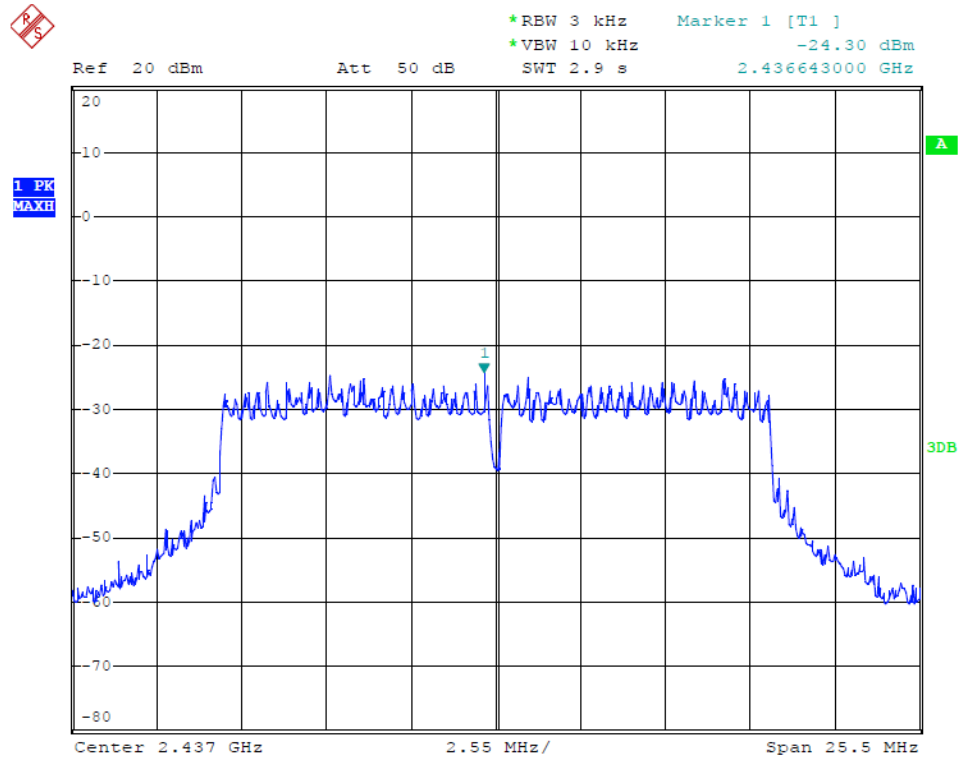



### 802.11g Channel High 2462MHz

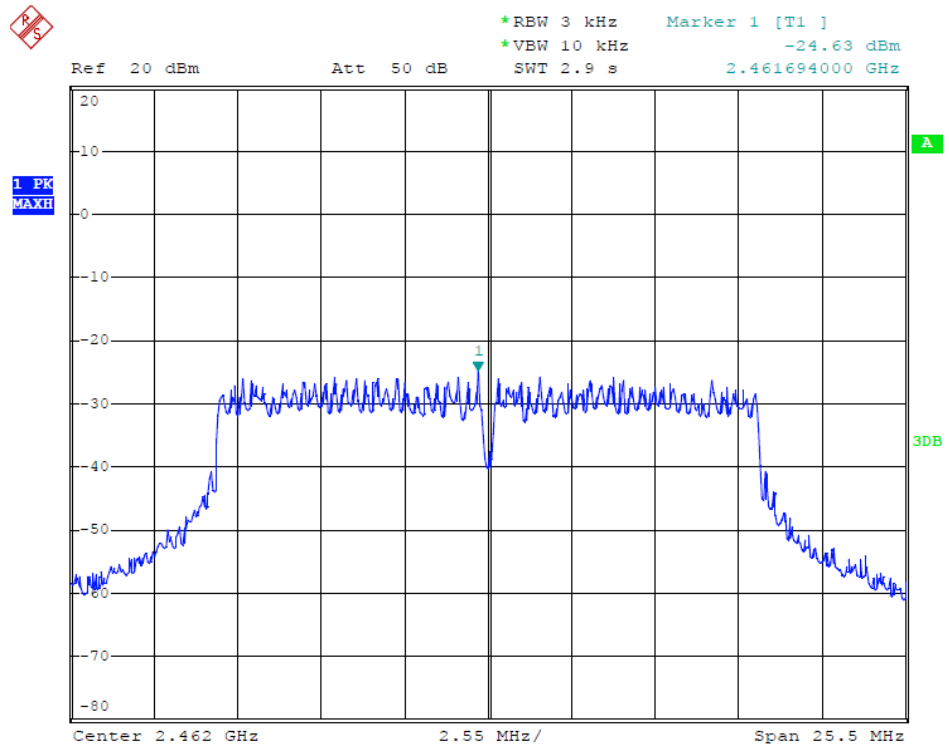

### 802.11n Channel Low 2412MHz (20MHz)

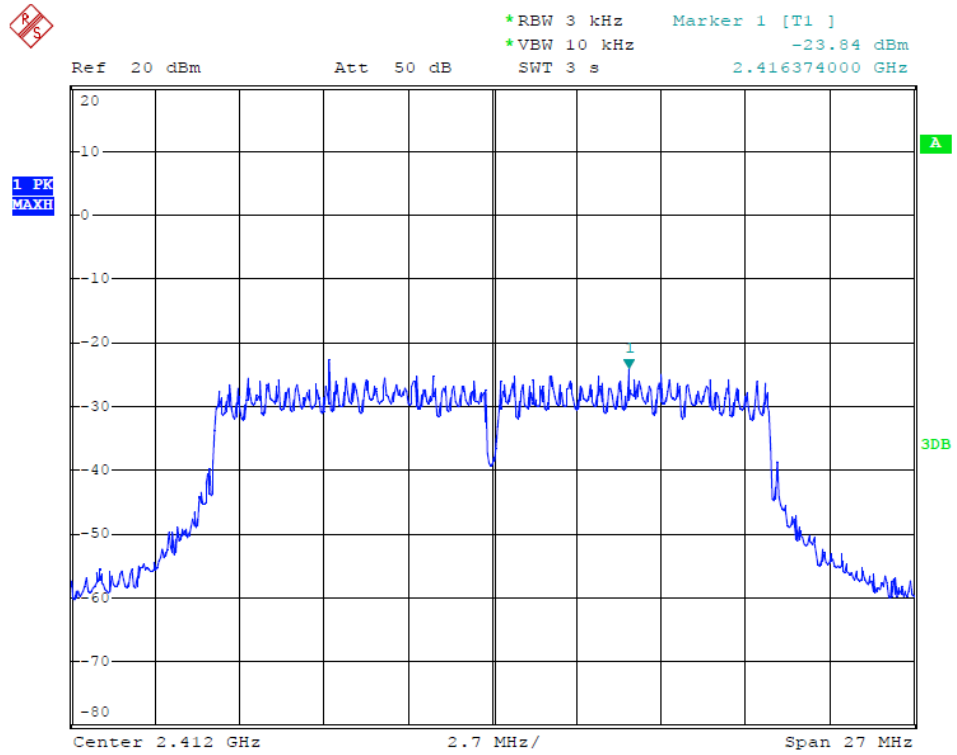

### 802.11n Channel Middle 2437MHz (20MHz)

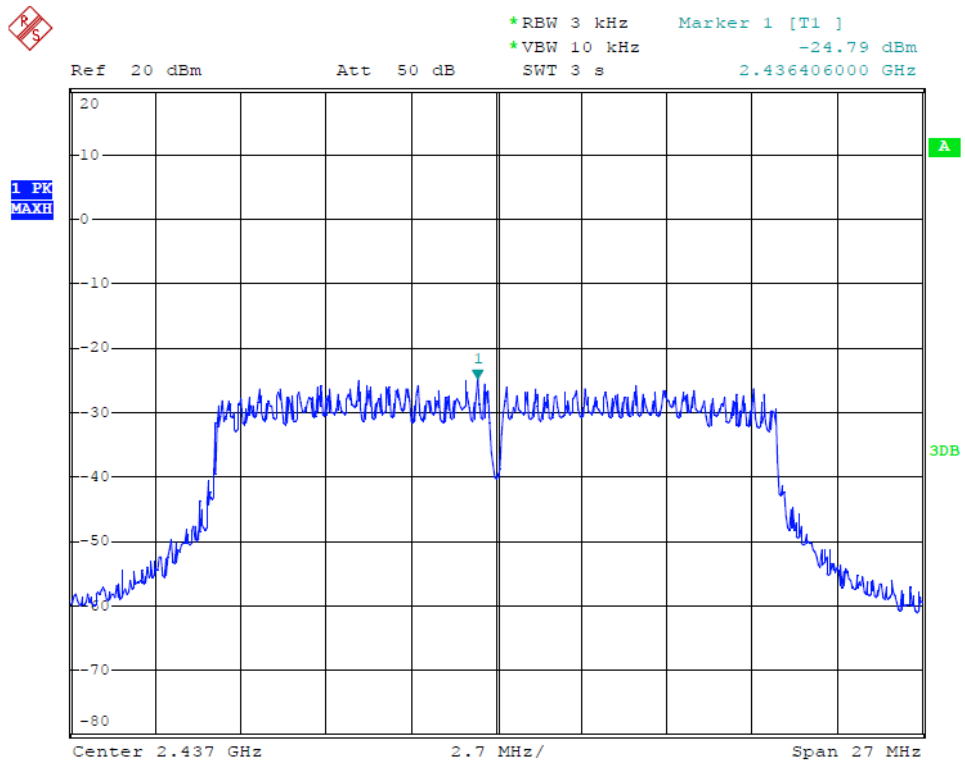

### 802.11n Channel High 2462MHz(20MHz)

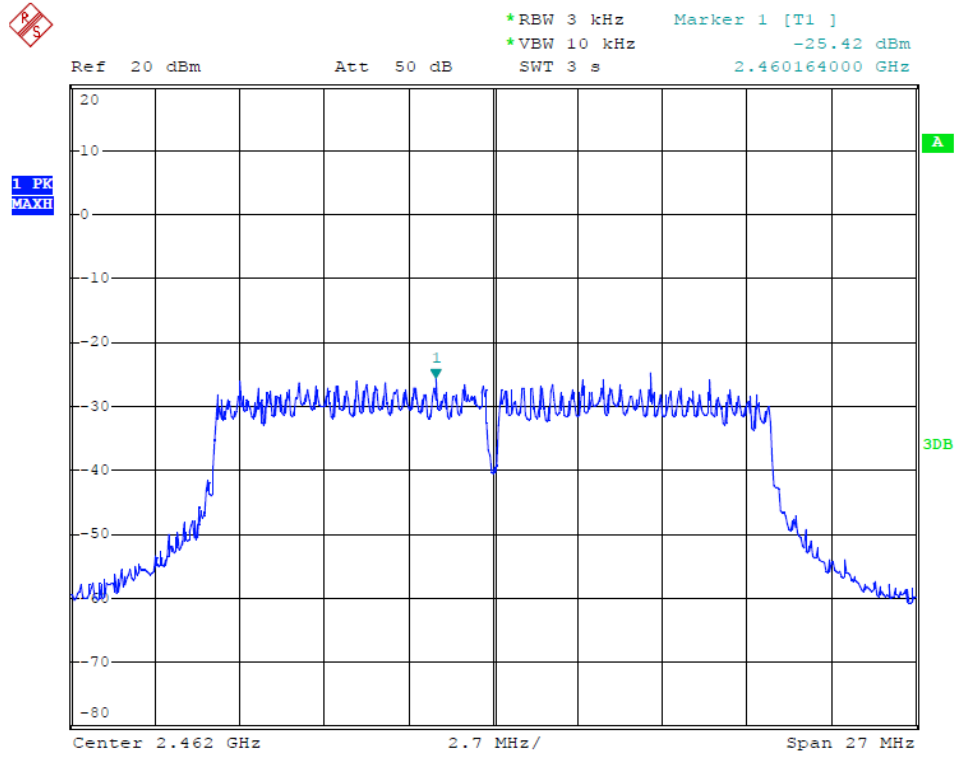

### 802.11n Channel Low 2422MHz (40MHz)

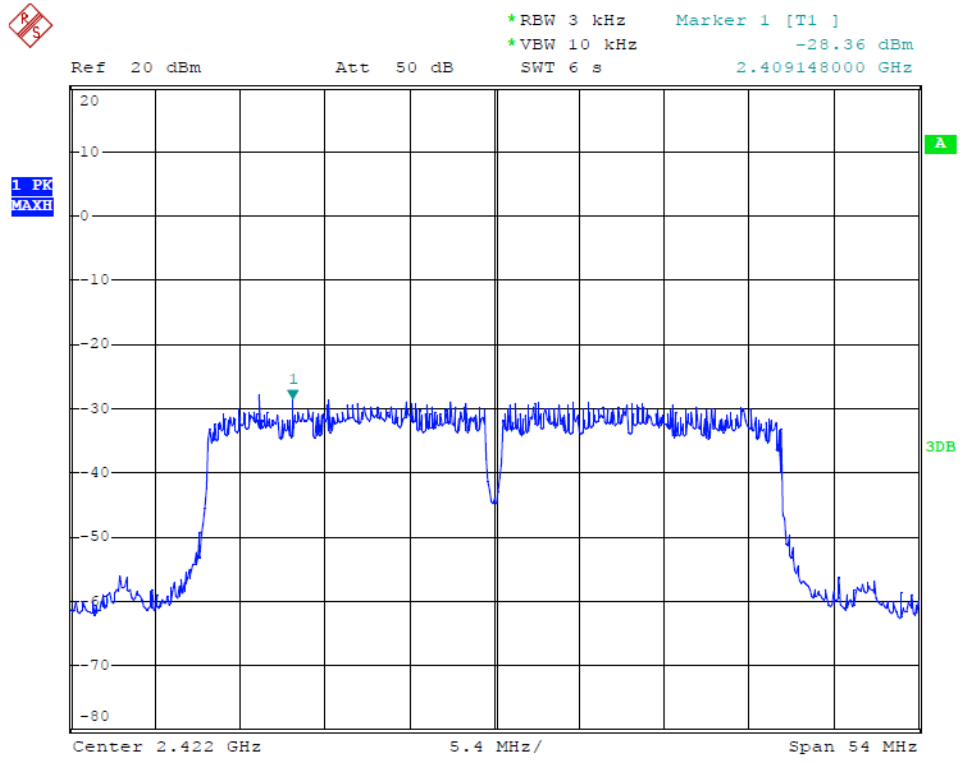

### 802.11n Channel Middle 2437MHz(40MHz)

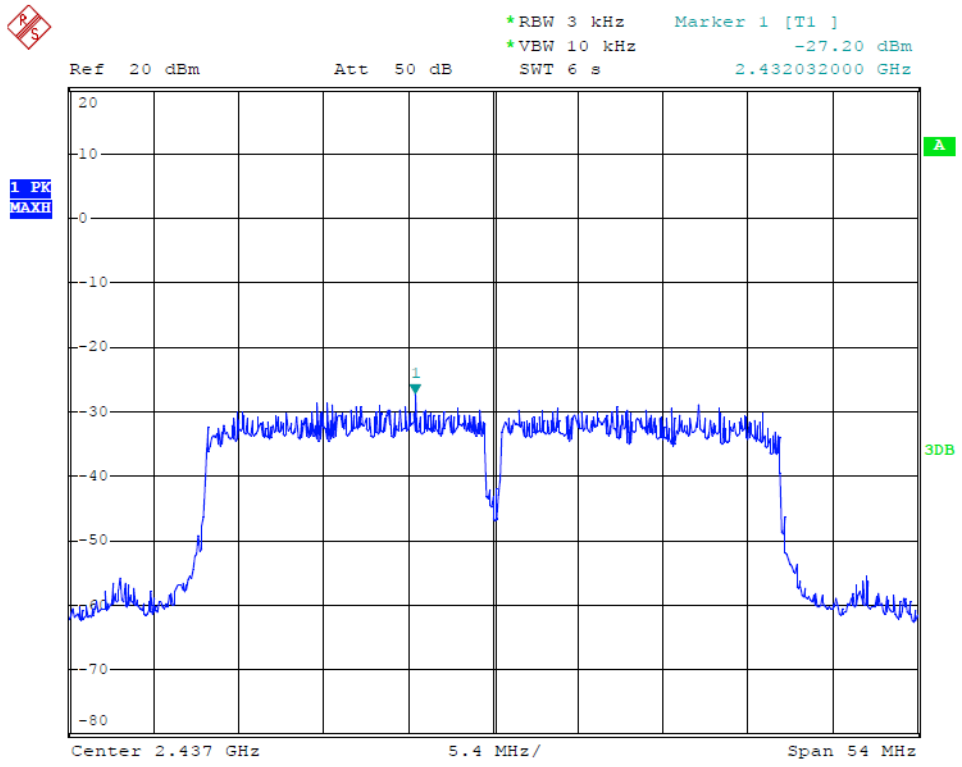

### 802.11n Channel High 2452MHz(40MHz)

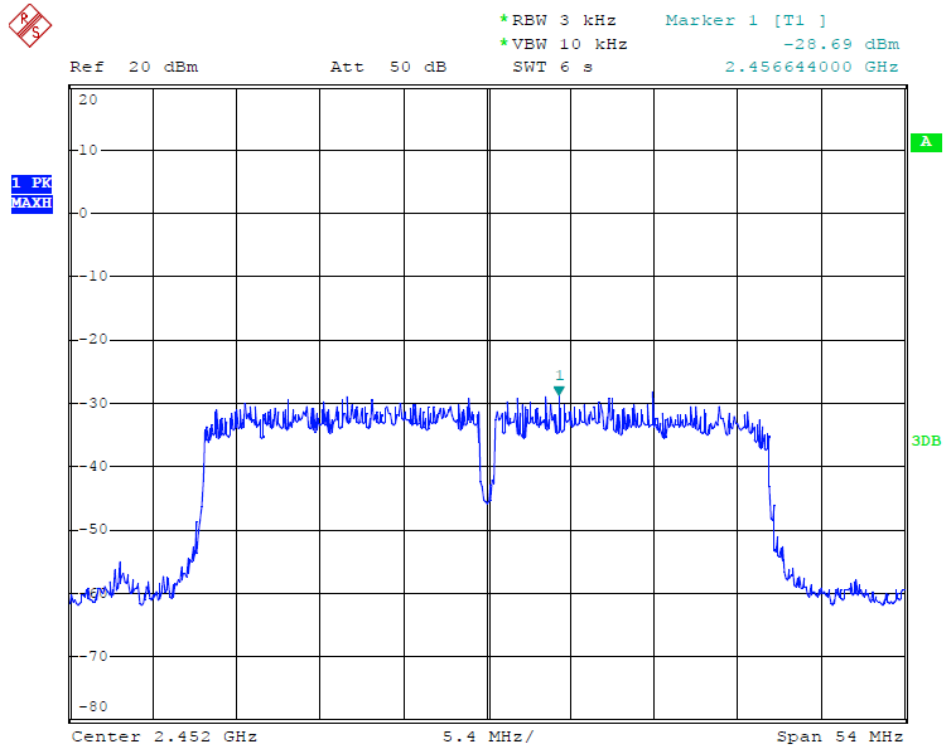

## 8. BAND EDGE COMPLIANCE TEST

### 8.1. Block Diagram of Test Setup

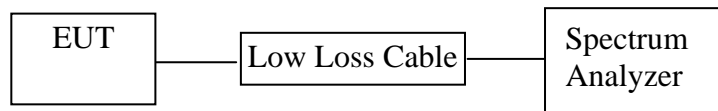

(EUT: Wifi Repeater)

### 8.2. The Requirement For Section 15.247(d)

Section 15.247(d): In any 100 kHz bandwidth outside the frequency band in which the spread spectrum or digitally modulated intentional radiator is operating, the radio frequency power that is produced by the intentional radiator shall be at least 20 dB below that in the 100 kHz bandwidth within the band that contains the highest level of the desired power, based on either an RF conducted or a radiated measurement, provided the transmitter demonstrates compliance with the peak conducted power limits. If the transmitter complies with the conducted power limits based on the use of RMS averaging over a time interval, as permitted under paragraph (b)(3) of this section, the attenuation required under this paragraph shall be 30 dB instead of 20 dB. Attenuation below the general limits specified in Section 15.209(a) is not required. In addition, radiated emissions which fall in the restricted bands, as defined in Section 15.205(a), must also comply with the radiated emission limits specified in Section 15.209(a).

### 8.3. EUT Configuration on Measurement

The following equipment are installed on the emission Measurement to meet the commission requirements and operating regulations in a manner which tends to maximize its emission characteristics in normal application.

#### 8.3.1. Wifi Repeater (EUT)

Model Number	:	VRP150
Serial Number	:	N/A
Manufacturer	:	Shenzhen HouTian Network Communication Technology Co., Ltd



## 8.4. Operating Condition of EUT

8.4.1. Setup the EUT and simulator as shown as Section 8.1.

8.4.2. Turn on the power of all equipment.

8.4.3. Let the EUT work in TX modes measure it. The transmit frequency are 2412-2462 and 2422-2452MHz MHz. We select 2412MHz, 2462MHz and 2422MHz, 2452MHz TX frequency to transmit.

## 8.5. Test Procedure

### Conducted Band Edge:

8.5.1. The transmitter output was connected to the spectrum analyzer via a low loss cable.

8.5.2. Set RBW of spectrum analyzer to 100kHz and VBW to 300kHz.

### Radiate Band Edge:

8.5.3. The EUT is placed on a turntable, which is 0.8m above the ground plane and worked at highest radiated power.

8.5.4. The turntable was rotated for 360 degrees to determine the position of maximum emission level.

8.5.5. EUT is set 3m away from the receiving antenna, which is varied from 1m to 4m to find out the highest emission.

8.5.6. Set the spectrum analyzer in the following setting in order to capture the lower and upper band-edges of the emission:

RBW=1MHz, VBW=1MHz

8.5.7. The band edges was measured and recorded.

## 8.6. Test Result

**Pass****Conducted test**

Date of Test:	July 25, 2013	Temperature:	25°C
EUT:	Wifi Repeater	Humidity:	50%
Model No.:	VRP150	Power Supply:	AC 120V/60Hz
Test Mode:	TX	Test Engineer:	Star

The test was performed with 802.11b

Frequency (MHz)	Result of Band Edge (dBc)	Limit of Band Edge (dBc)
2412	38.02	> 20dBc
2462	39.35	> 20dBc

The test was performed with 802.11g

Frequency (MHz)	Result of Band Edge (dBc)	Limit of Band Edge (dBc)
2412	31.11	> 20dBc
2462	31.68	> 20dBc

The test was performed with 802.11n (20MHz)

Frequency (MHz)	Result of Band Edge (dBc)	Limit of Band Edge (dBc)
2412	27.83	> 20dBc
2462	31.81	> 20dBc

The test was performed with 802.11n (40MHz)

Frequency (MHz)	Result of Band Edge (dBc)	Limit of Band Edge (dBc)
2422	26.18	> 20dBc
2452	28.88	> 20dBc

### 802.11b Channel Low 2412MHz

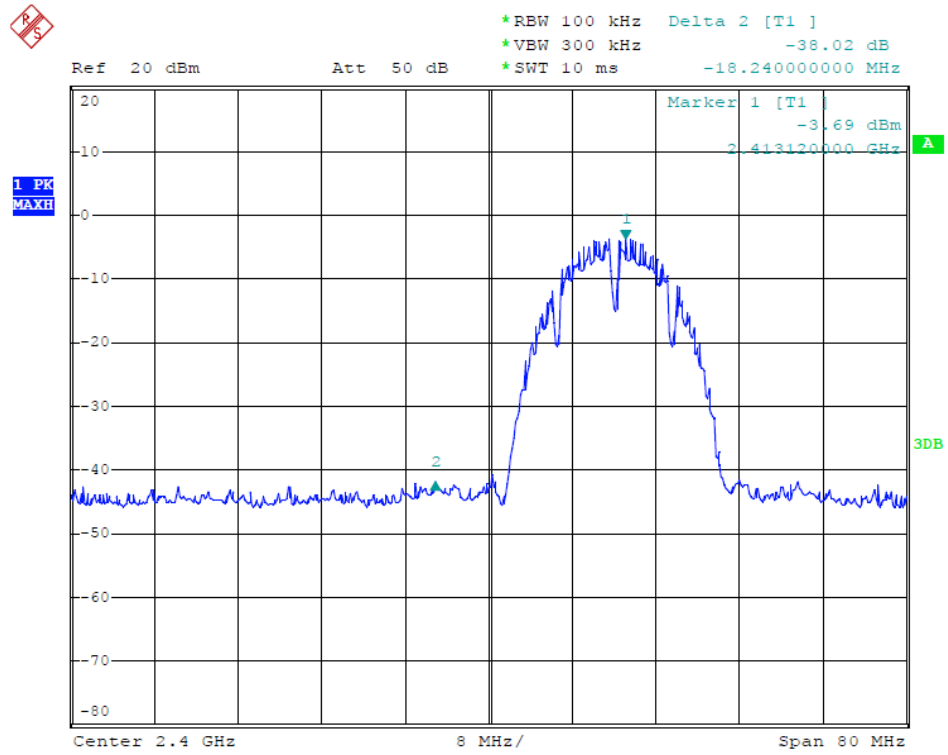

### 802.11b Channel High 2462MHz

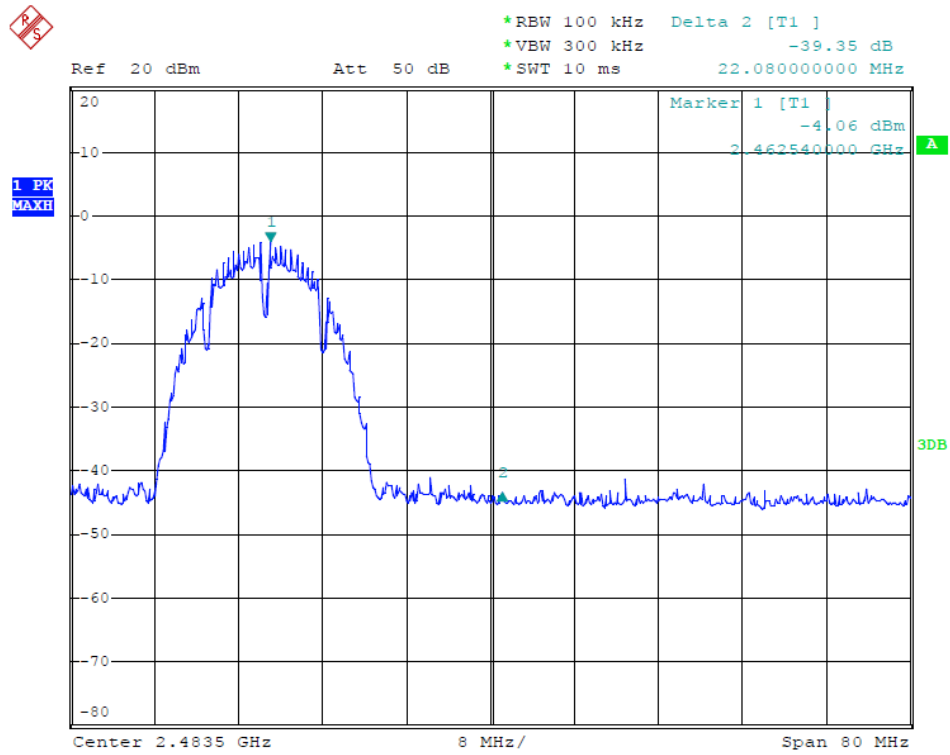

### 802.11g Channel Low 2412MHz

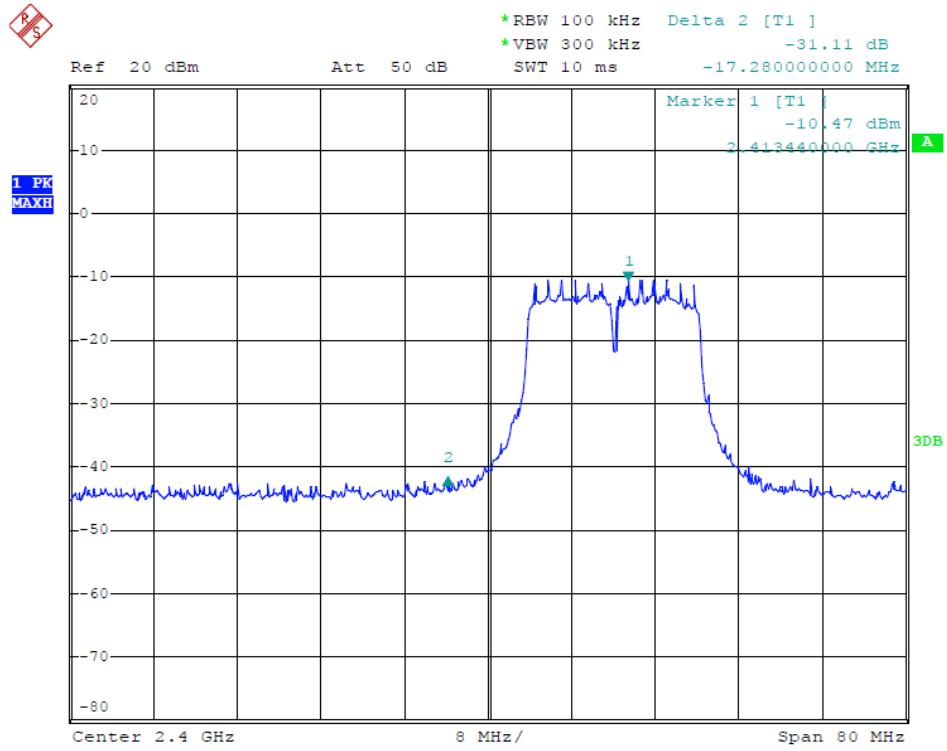

### 802.11g Channel High 2462MHz

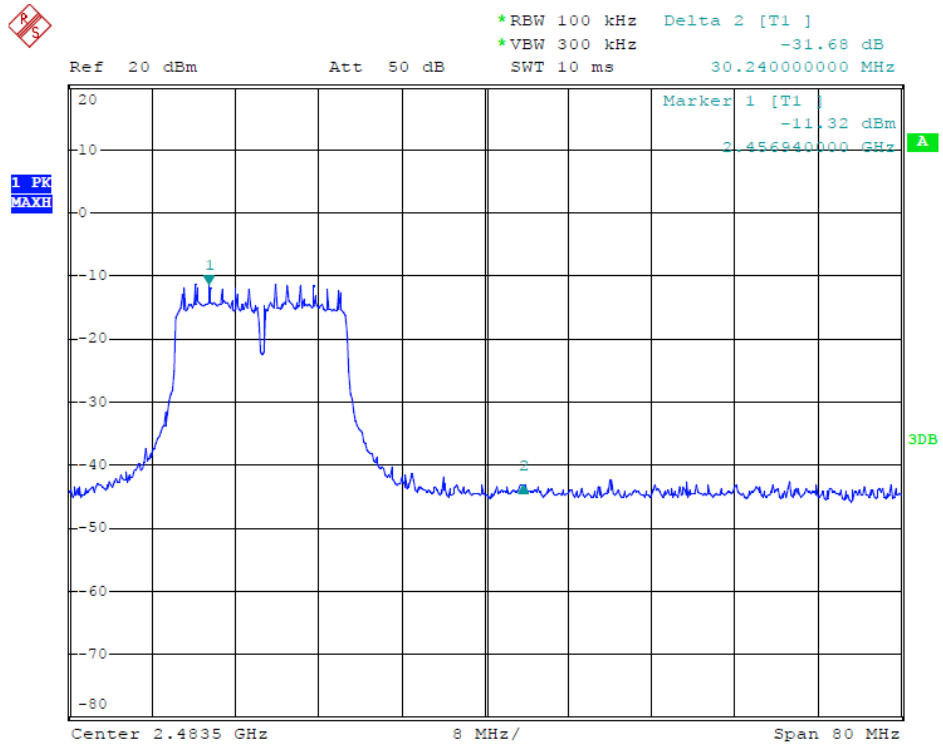

### 802.11n Channel Low 2412MHz (20MHz)

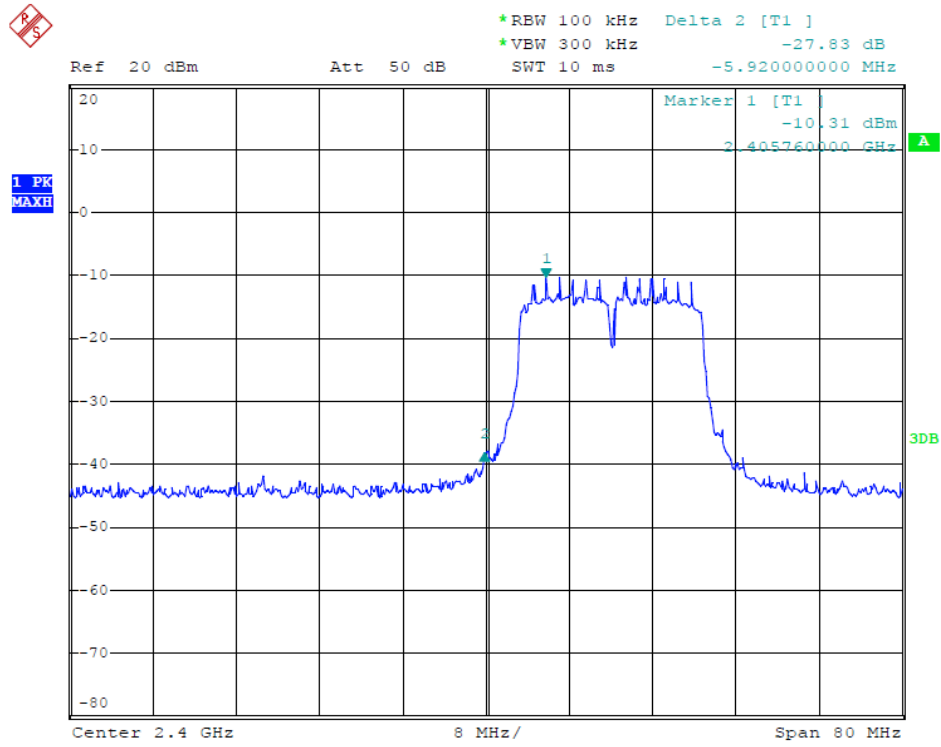

### 802.11n Channel High 2462MHz (20MHz)

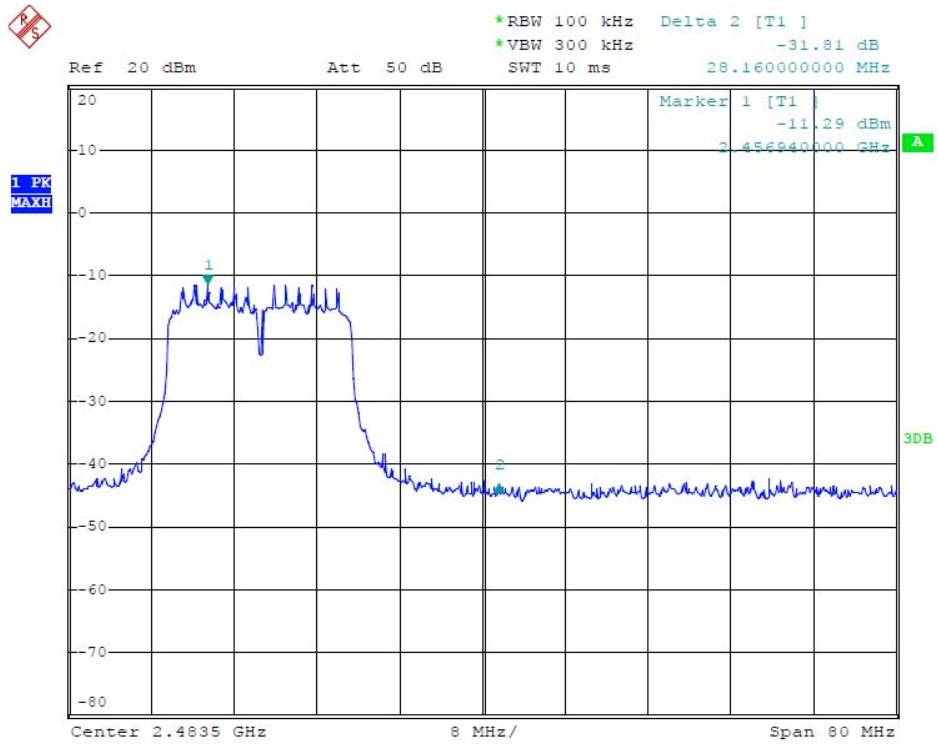



### 802.11n Channel Low 2422MHz (40MHz)

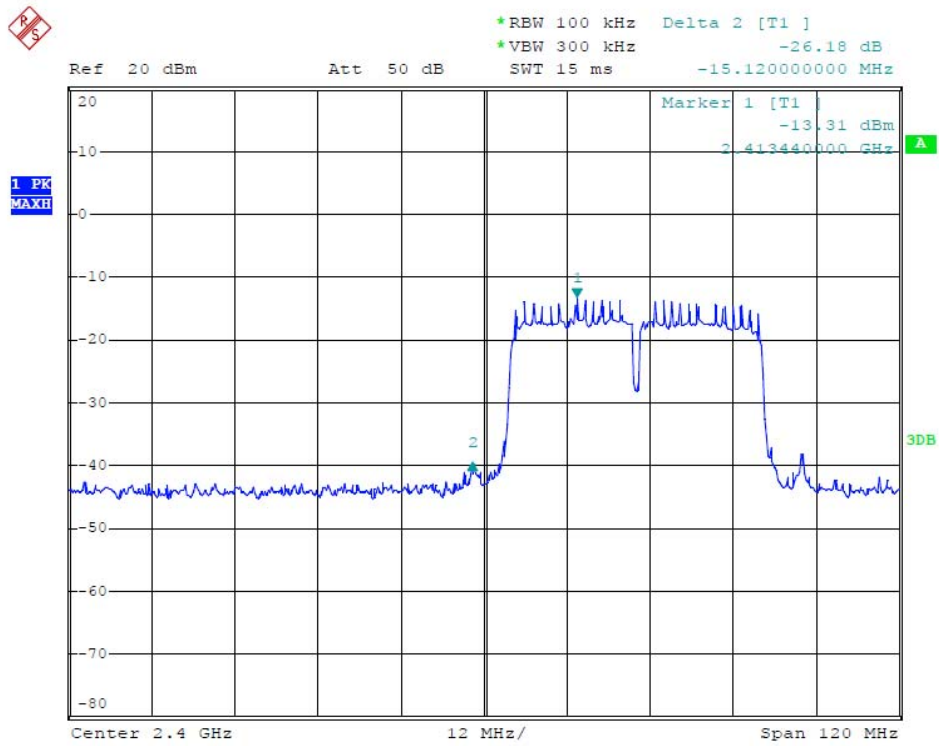

### 802.11n Channel High 2452MHz (40MHz)

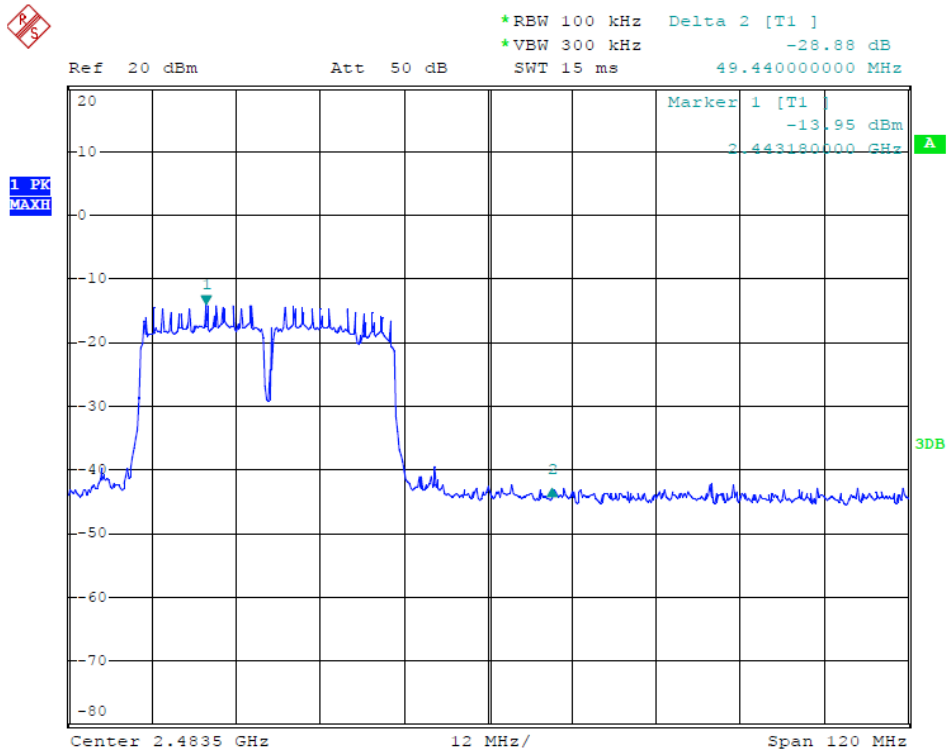

**Radiated Band Edge Result**

Date of Test:	<u>July 25, 2013</u>	Temperature:	<u>25°C</u>
EUT:	<u>Wifi Repeater</u>	Humidity:	<u>50%</u>
Model No.:	<u>VRP150</u>	Power Supply:	<u>AC 120V/60Hz</u>
Test Mode:	<u>802.11b Channel Low 2412MHz</u>	Test Engineer:	<u>Star</u>

Frequency (MHz)	Reading(dBμV/m)		Factor(dB) Corr.	Result(dBμV/m)		Limit(dBμV/m)		Margin(dB)		Polarization
	AV	PEAK		AV	PEAK	AV	PEAK	AV	PEAK	
2310.000	40.00	49.97	-7.81	32.19	42.16	54.00	74.00	-21.81	-31.84	Vertical
2359.168	40.28	51.20	-7.73	32.55	43.47	54.00	74.00	-21.45	-30.53	Vertical
2390.000	42.82	51.04	-7.53	35.29	43.51	54.00	74.00	-18.71	-30.49	Vertical
2310.000	39.18	46.79	-7.81	31.37	38.98	54.00	74.00	-22.63	-35.02	Horizontal
2342.882	40.15	48.46	-7.79	32.36	40.67	54.00	74.00	-21.64	-33.33	Horizontal
2390.000	36.99	43.96	-7.53	29.46	36.43	54.00	74.00	-24.54	-37.57	Horizontal

## Note:

1. Emissions attenuated more than 20 dB below the permissible value are not reported.
2. The field strength is calculated by adding the antenna factor, high pass filter loss(if used) and cable loss, and subtracting the amplifier gain(if any)from the measured reading. The basic equation calculation is as follows:  

$$\text{Result} = \text{Reading} + \text{Corrected Factor}$$
3. Display the measurement of peak values.

Date of Test:	<u>July 25, 2013</u>	Temperature:	<u>25°C</u>
EUT:	<u>Wifi Repeater</u>	Humidity:	<u>50%</u>
Model No.:	<u>VRP150</u>	Power Supply:	<u>AC 120V/60Hz</u>
Test Mode:	<u>802.11b Channel High 2462MHz</u>	Test Engineer:	<u>Star</u>

Frequency (MHz)	Reading(dBμV/m)		Factor(dB) Corr.	Result(dBμV/m)		Limit(dBμV/m)		Margin(dB)		Polarization
	AV	PEAK		AV	PEAK	AV	PEAK	AV	PEAK	
2483.500	35.11	45.88	-7.37	27.74	38.51	54.00	74.00	26.26	-35.49	Vertical
2491.627	36.18	47.66	-7.39	28.79	40.27	54.00	74.00	-25.21	-33.73	Vertical
2500.000	34.28	43.96	-7.40	26.88	35.56	54.00	74.00	-27.12	-37.44	Vertical
2483.500	33.69	44.87	-7.37	26.32	37.50	54.00	74.00	-27.68	-36.50	Horizontal
2494.641	35.28	46.34	-7.39	27.89	38.95	54.00	74.00	-26.11	-35.05	Horizontal
2500.000	31.28	43.81	-7.40	23.88	36.41	54.00	74.00	-30.12	-37.59	Horizontal

## Note:

1. Emissions attenuated more than 20 dB below the permissible value are not reported.
2. The field strength is calculated by adding the antenna factor, high pass filter loss(if used) and cable loss, and subtracting the amplifier gain(if any)from the measured reading. The basic equation calculation is as follows:  
Result = Reading + Corrected Factor
3. Display the measurement of peak values.

Date of Test:	<u>July 25, 2013</u>	Temperature:	<u>25°C</u>
EUT:	<u>Wifi Repeater</u>	Humidity:	<u>50%</u>
Model No.:	<u>VRP150</u>	Power Supply:	<u>DC 5V</u>
Test Mode:	<u>802.11g Channel Low 2412MHz</u>	Test Engineer:	<u>Star</u>

Frequency (MHz)	Reading(dBμV/m)		Factor(dB) Corr.	Result(dBμV/m)		Limit(dBμV/m)		Margin(dB)		Polarization
	AV	PEAK		AV	PEAK	AV	PEAK	AV	PEAK	
2310.000	37.61	48.53	-7.81	29.80	40.72	54.00	74.00	-24.20	-33.28	Vertical
2345.380	38.29	50.02	-7.79	30.50	42.23	54.00	74.00	-23.50	-31.77	Vertical
2390.000	35.91	46.54	-7.53	28.38	39.01	54.00	74.00	-25.62	-34.99	Vertical
2310.000	38.91	47.47	-7.81	31.10	39.66	54.00	74.00	-22.90	-34.34	Horizontal
2344.686	38.22	49.93	-7.79	30.43	42.14	54.00	74.00	-23.57	-31.86	Horizontal
2390.000	36.43	45.66	-7.53	28.90	38.13	54.00	74.00	-25.10	-35.87	Horizontal

## Note:

1. Emissions attenuated more than 20 dB below the permissible value are not reported.
2. The field strength is calculated by adding the antenna factor, high pass filter loss(if used) and cable loss, and subtracting the amplifier gain(if any)from the measured reading. The basic equation calculation is as follows:  

$$\text{Result} = \text{Reading} + \text{Corrected Factor}$$
3. Display the measurement of peak values.

Date of Test:	<u>July 25, 2013</u>	Temperature:	<u>25°C</u>
EUT:	<u>Wifi Repeater</u>	Humidity:	<u>50%</u>
Model No.:	<u>VRP150</u>	Power Supply:	<u>DC 5V</u>
Test Mode:	<u>802.11g Channel High 2462MHz</u>	Test Engineer:	<u>Star</u>

Frequency (MHz)	Reading(dBμV/m)		Factor(dB) Corr.	Result(dBμV/m)		Limit(dBμV/m)		Margin(dB)		Polarization
	AV	PEAK		AV	PEAK	AV	PEAK	AV	PEAK	
2483.500	34.17	45.47	-7.37	26.80	38.10	54.00	74.00	-27.20	-35.90	Vertical
2494.006	35.91	46.64	-7.40	28.51	39.24	54.00	74.00	-25.49	-34.76	Vertical
2500.000	32.58	44.82	-7.40	25.18	37.42	54.00	74.00	-28.82	-36.58	Vertical
2483.500	34.67	44.50	-7.37	27.30	37.13	54.00	74.00	-26.70	-36.87	Horizontal
2493.848	34.19	45.47	-7.40	26.79	38.07	54.00	74.00	-27.21	-35.93	Horizontal
2500.000	36.48	45.21	-7.40	29.08	37.81	54.00	74.00	-24.92	-36.19	Horizontal

## Note:

1. Emissions attenuated more than 20 dB below the permissible value are not reported.
2. The field strength is calculated by adding the antenna factor, high pass filter loss(if used) and cable loss, and subtracting the amplifier gain(if any)from the measured reading. The basic equation calculation is as follows:  
Result = Reading + Corrected Factor
3. Display the measurement of peak values.

Date of Test:	<u>July 25, 2013</u>	Temperature:	<u>25°C</u>
EUT:	<u>Wifi Repeater</u>	Humidity:	<u>50%</u>
Model No.:	<u>VRP150</u>	Power Supply:	<u>DC 5V</u>
	<u>802.11n Channel Low 2412MHz</u>		
Test Mode:	<u>(20MHz)</u>	Test Engineer:	<u>Star</u>

Frequency (MHz)	Reading(dBμV/m)		Factor(dB) Corr.	Result(dBμV/m)		Limit(dBμV/m)		Margin(dB)		Polarization
	AV	PEAK		AV	PEAK	AV	PEAK	AV	PEAK	
2310.000	39.33	48.26	-7.81	31.52	40.45	54.00	74.00	-22.48	-33.55	Vertical
2358.191	39.36	50.86	-7.74	31.62	43.12	54.00	74.00	-22.38	-30.88	Vertical
2390.000	34.58	44.94	-7.53	27.05	37.41	54.00	74.00	-26.95	-36.59	Vertical
2310.000	39.24	47.88	-7.81	31.43	40.07	54.00	74.00	-22.57	-33.93	Horizontal
2343.160	39.88	50.17	-7.79	32.09	42.38	54.00	74.00	-21.91	-31.62	Horizontal
2390.000	34.81	45.76	-7.53	27.28	38.23	54.00	74.00	-26.72	-35.77	Horizontal

## Note:

1. Emissions attenuated more than 20 dB below the permissible value are not reported.
2. The field strength is calculated by adding the antenna factor, high pass filter loss(if used) and cable loss, and subtracting the amplifier gain(if any)from the measured reading. The basic equation calculation is as follows:  

$$\text{Result} = \text{Reading} + \text{Corrected Factor}$$
3. Display the measurement of peak values.

Date of Test:	<u>July 25, 2013</u>	Temperature:	<u>25°C</u>
EUT:	<u>Wifi Repeater</u>	Humidity:	<u>50%</u>
Model No.:	<u>VRP150</u>	Power Supply:	<u>DC 5V</u>
	<u>802.11n Channel High 2462MHz</u>		
Test Mode:	<u>(20MHz)</u>	Test Engineer:	<u>Star</u>

Frequency (MHz)	Reading(dBμV/m)		Factor(dB) Corr.	Result(dBμV/m)		Limit(dBμV/m)		Margin(dB)		Polarization
	AV	PEAK		AV	PEAK	AV	PEAK	AV	PEAK	
2483.500	33.80	44.77	-7.37	26.43	37.40	54.00	74.00	-27.57	-36.60	Vertical
2492.102	35.17	48.02	-7.39	27.78	40.63	54.00	74.00	-26.22	-33.37	Vertical
2500.000	32.93	44.65	-7.40	25.53	37.25	54.00	74.00	-28.47	-36.75	Vertical
2483.500	34.28	45.40	-7.37	26.91	38.03	54.00	74.00	-27.09	-35.97	Horizontal
2493.372	37.92	46.17	-7.39	30.53	38.78	54.00	74.00	-23.47	-35.22	Horizontal
2500.000	35.91	44.68	-7.40	28.51	37.28	54.00	74.00	-25.49	-36.72	Horizontal

## Note:

1. Emissions attenuated more than 20 dB below the permissible value are not reported.
2. The field strength is calculated by adding the antenna factor, high pass filter loss(if used) and cable loss, and subtracting the amplifier gain(if any)from the measured reading. The basic equation calculation is as follows:  
Result = Reading + Corrected Factor
3. Display the measurement of peak values.



Date of Test:	<u>April 9, 2013</u>	Temperature:	<u>25°C</u>
EUT:	<u>Wifi Repeater</u>	Humidity:	<u>50%</u>
Model No.:	<u>VRP150</u>	Power Supply:	<u>DC 5V</u>
	<u>802.11n Channel Low 2422MHz</u>		
Test Mode:	<u>(40MHz)</u>	Test Engineer:	<u>Star</u>

Frequency (MHz)	Reading(dBμV/m)		Factor(dB) Corr.	Result(dBμV/m)		Limit(dBμV/m)		Margin(dB)		Polarization
	AV	PEAK		AV	PEAK	AV	PEAK	AV	PEAK	
2310.000	43.08	50.94	-7.81	35.27	43.13	54.00	74.00	-18.73	-30.87	Vertical
2342.646	42.18	52.49	7.79	34.39	44.70	54.00	74.00	-19.61	-29.30	Vertical
2390.000	43.99	51.17	-7.53	36.46	43.64	54.00	74.00	-17.54	-30.36	Vertical
2310.000	40.28	47.08	-7.81	32.47	39.27	54.00	74.00	-21.53	-34.73	Horizontal
2335.020	43.17	50.71	-7.80	35.37	42.91	54.00	74.00	-18.63	-31.09	Horizontal
2390.000	39.83	47.97	-7.53	32.30	40.44	54.00	74.00	-21.70	-33.56	Horizontal

## Note:

1. Emissions attenuated more than 20 dB below the permissible value are not reported.
2. The field strength is calculated by adding the antenna factor, high pass filter loss(if used) and cable loss, and subtracting the amplifier gain(if any)from the measured reading. The basic equation calculation is as follows:  

$$\text{Result} = \text{Reading} + \text{Corrected Factor}$$
3. Display the measurement of peak values.

Date of Test:	<u>April 9, 2013</u>	Temperature:	<u>25°C</u>
EUT:	<u>Wifi Repeater</u>	Humidity:	<u>50%</u>
Model No.:	<u>VRP150</u>	Power Supply:	<u>DC 5V</u>
Test Mode:	<u>802.11n Channel High 2452MHz</u>	Test Engineer:	<u>Star</u>
	<u>(40MHz)</u>		

Frequency (MHz)	Reading(dBμV/m)		Factor(dB) Corr.	Result(dBμV/m)		Limit(dBμV/m)		Margin(dB)		Polarization
	AV	PEAK		AV	PEAK	AV	PEAK	AV	PEAK	
2483.500	41.89	48.40	-7.37	34.52	41.03	54.00	74.00	-19.48	-32.97	Vertical
2494.262	41.00	48.52	-7.39	33.61	41.13	54.00	74.00	-20.39	-32.87	Vertical
2500.000	38.91	46.08	-7.40	31.51	38.68	54.00	74.00	-22.49	-35.32	Vertical
2483.500	35.17	44.87	-7.37	27.80	37.50	54.00	74.00	-26.20	-36.50	Horizontal
2494.262	36.99	46.29	-7.39	29.60	38.90	54.00	74.00	-24.40	-35.10	Horizontal
2500.000	33.55	44.48	-7.40	26.15	37.08	54.00	74.00	-27.85	-36.92	Horizontal

Note:

1. Emissions attenuated more than 20 dB below the permissible value are not reported.
2. The field strength is calculated by adding the antenna factor, high pass filter loss(if used) and cable loss, and subtracting the amplifier gain(if any)from the measured reading. The basic equation calculation is as follows:  
Result = Reading + Corrected Factor
3. Display the measurement of peak values.

**ACCURATE TECHNOLOGY CO., LTD.**

 F1,Bldg,A,Changyuan New Material Port Keyuan Rd,  
 Science & Industry Park,Nanshan Shenzhen,P.R.China

Site: 2# chamber

Tel:+86-0755-26503290

Fax:+86-0755-26503396

Job No.: star #2901

Standard: FCC 15C PK

Test item: Radiation Test

Temp.( C)/Hum.(%) 23 C / 49 %

EUT: Wifi Repeater

Mode: TX Channel 1(802.11b)

Model: VRP150

Manufacturer: HouTian

Polarization: Horizontal

Power Source: DC 5V

Date: 13/07/25/

Time: 13/18/32

Engineer Signature:

Distance: 3m

Note: Report No.:ATE20131606

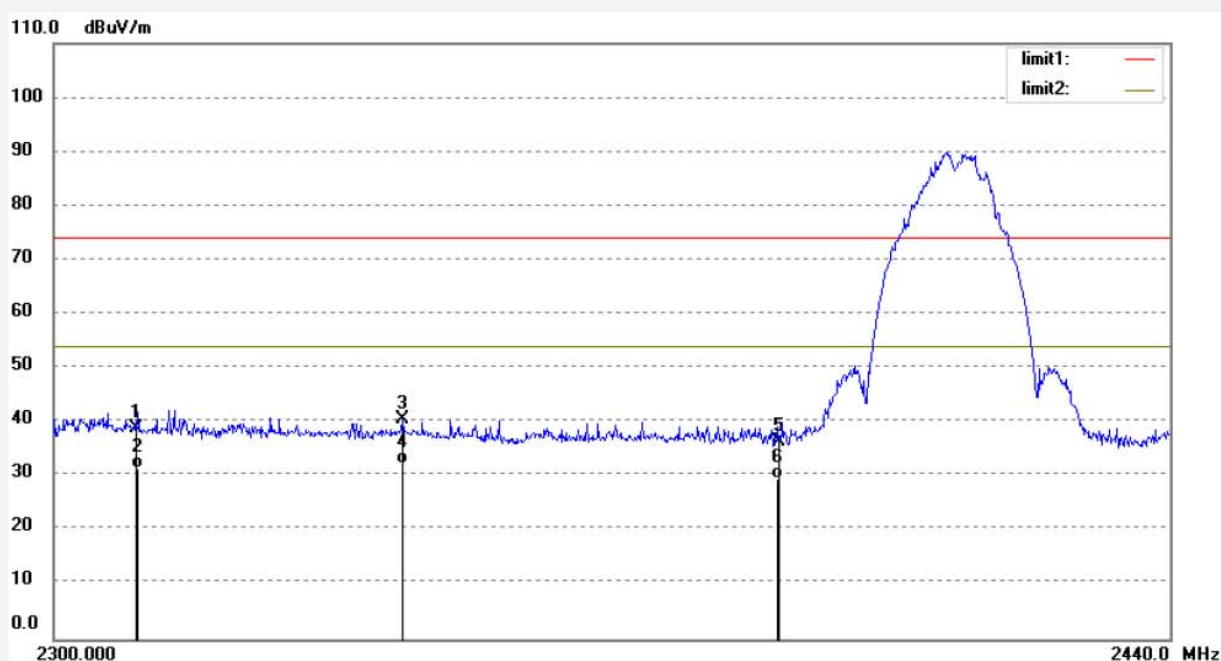

No.	Freq. (MHz)	Reading (dBuV/m)	Factor (dB)	Result (dBuV/m)	Limit (dBuV/m)	Margin (dB)	Detector	Height (cm)	Degree (deg.)	Remark
1	2310.000	46.79	-7.81	38.98	74.00	-35.02	peak			
2	2310.000	39.18	-7.81	31.37	54.00	-22.63	AVG			
3	2342.882	48.46	-7.79	40.67	74.00	-33.33	peak			
4	2342.882	40.15	-7.79	32.36	54.00	-21.64	AVG			
5	2390.000	43.96	-7.53	36.43	74.00	-37.57	peak			
6	2390.000	36.99	-7.53	29.46	54.00	-24.54	AVG			

**ACCURATE TECHNOLOGY CO., LTD.**

 F1,Bldg,A,Changyuan New Material Port Keyuan Rd,  
 Science & Industry Park,Nanshan Shenzhen,P.R.China

Site: 2# chamber

Tel:+86-0755-26503290

Fax:+86-0755-26503396

Job No.: star #2902

Standard: FCC 15C PK

Test item: Radiation Test

Temp.( C)/Hum.(%) 23 C / 49 %

EUT: Wifi Repeater

Mode: TX Channel 1(802.11b)

Model: VRP150

Manufacturer: HouTian

Polarization: Vertical

Power Source: DC 5V

Date: 13/07/25/

Time: 13/22/34

Engineer Signature:

Distance: 3m

Note: Report No.:ATE20131606

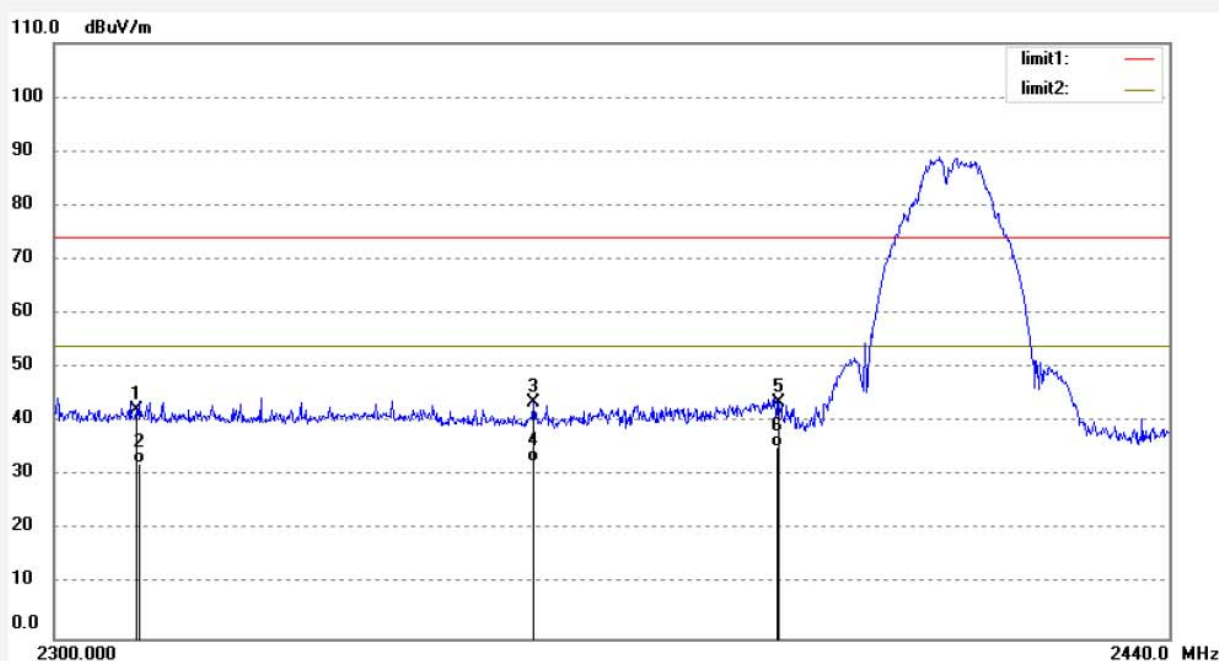

No.	Freq. (MHz)	Reading (dBuV/m)	Factor (dB)	Result (dBuV/m)	Limit (dBuV/m)	Margin (dB)	Detector	Height (cm)	Degree (deg.)	Remark
1	2310.000	49.97	-7.81	42.16	74.00	-31.84	peak			
2	2310.000	40.00	-7.81	32.19	54.00	-21.81	AVG			
3	2359.168	51.20	-7.73	43.47	74.00	-30.53	peak			
4	2359.168	40.28	-7.73	32.55	54.00	-21.45	AVG			
5	2390.000	51.04	-7.53	43.51	74.00	-30.49	peak			
6	2390.000	42.82	-7.53	35.29	54.00	-18.71	AVG			



**ACCURATE TECHNOLOGY CO., LTD.**

F1,Bldg.A,Changyuan New Material Port Keyuan Rd,  
Science & Industry Park,Nanshan Shenzhen,P.R.China

Site: 2# chamber  
Tel:+86-0755-26503290  
Fax:+86-0755-26503396

Job No.: star #2903	Polarization: Vertical
Standard: FCC 15C PK	Power Source: DC 5V
Test item: Radiation Test	Date: 13/07/25/
Temp.( C)/Hum.(%) 23 C / 49 %	Time: 13/27/41
EUT: Wifi Repeater	Engineer Signature:
Mode: TX Channel 11(802.11b)	Distance: 3m
Model: VRP150	
Manufacturer: HouTian	

Note: Report No.:ATE20131606

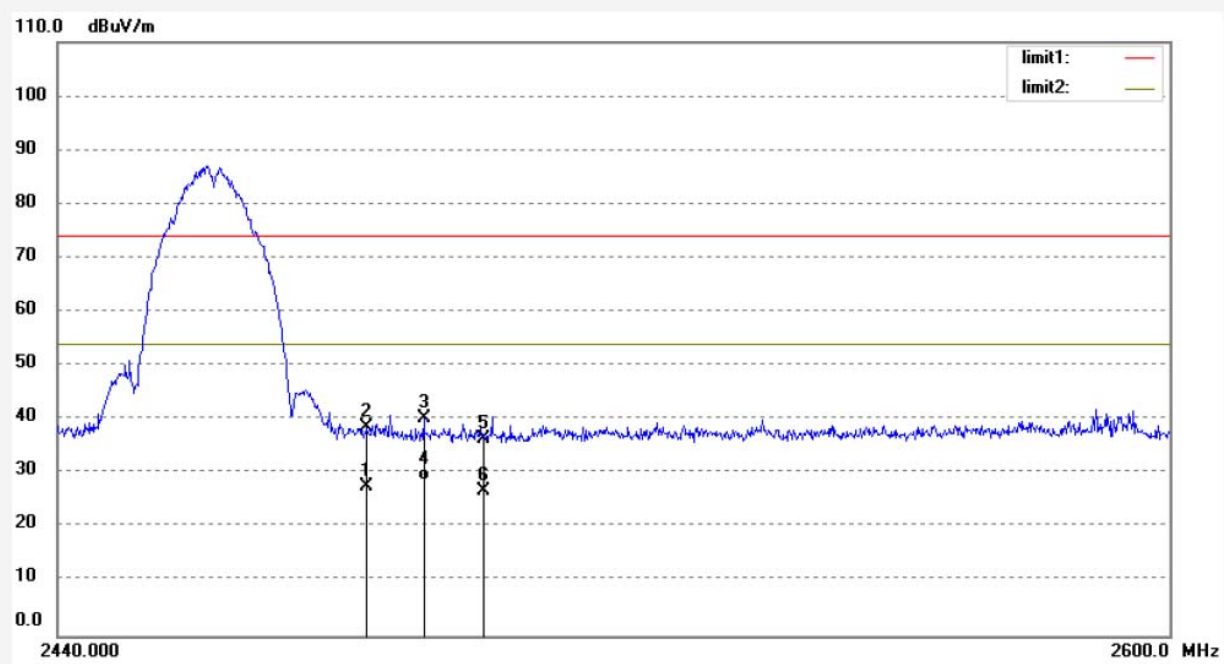

No.	Freq. (MHz)	Reading (dBuV/m)	Factor (dB)	Result (dBuV/m)	Limit (dBuV/m)	Margin (dB)	Detector	Height (cm)	Degree (deg.)	Remark
1	2483.500	35.11	-7.37	27.74	54.00	-26.26	AVG			
2	2483.500	45.88	-7.37	38.51	74.00	-35.49	peak			
3	2491.627	47.66	-7.39	40.27	74.00	-33.73	peak			
4	2491.627	36.18	-7.39	28.79	54.00	-25.21	AVG			
5	2500.000	43.96	-7.40	36.56	74.00	-37.44	peak			
6	2500.000	34.28	-7.40	26.88	54.00	-27.12	AVG			



**ACCURATE TECHNOLOGY CO., LTD.**

F1,Bldg,A,Changyuan New Material Port Keyuan Rd,  
Science & Industry Park,Nanshan Shenzhen,P.R.China

Site: 2# chamber  
Tel:+86-0755-26503290  
Fax:+86-0755-26503396

Job No.: star #2904  
Standard: FCC 15C PK  
Test item: Radiation Test  
Temp.( C)/Hum.(%) 23 C / 49 %  
EUT: Wifi Repeater  
Mode: TX Channel 11(802.11b)  
Model: VRP150  
Manufacturer: HouTian

Polarization: Horizontal  
Power Source: DC 5V  
Date: 13/07/25/  
Time: 13/32/24  
Engineer Signature:  
Distance: 3m

Note: Report No.:ATE20131606

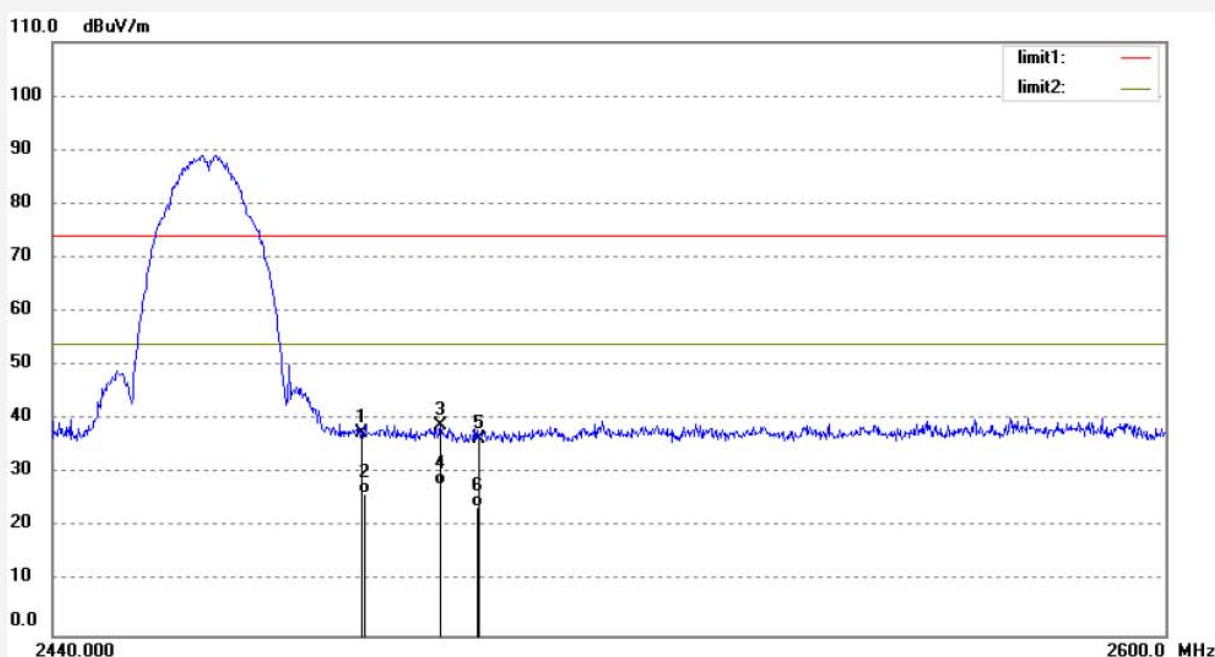

No.	Freq. (MHz)	Reading (dBuV/m)	Factor (dB)	Result (dBuV/m)	Limit (dBuV/m)	Margin (dB)	Detector	Height (cm)	Degree (deg.)	Remark
1	2483.500	44.87	-7.37	37.50	74.00	-36.50	peak			
2	2483.500	33.69	-7.37	26.32	54.00	-27.68	AVG			
3	2494.641	46.34	-7.39	38.95	74.00	-35.05	peak			
4	2494.641	35.28	-7.39	27.89	54.00	-26.11	AVG			
5	2500.000	43.81	-7.40	36.41	74.00	-37.59	peak			
6	2500.000	31.28	-7.40	23.88	54.00	-30.12	AVG			



**ACCURATE TECHNOLOGY CO., LTD.**

F1,Bldg,A,Changyuan New Material Port Keyuan Rd,  
Science & Industry Park,Nanshan Shenzhen,P.R.China

Site: 2# chamber  
Tel:+86-0755-26503290  
Fax:+86-0755-26503396

Job No.: star #2908	Polarization: Horizontal
Standard: FCC 15C PK	Power Source: DC 5V
Test item: Radiation Test	Date: 13/07/25/
Temp.( C)/Hum.(%) 23 C / 49 %	Time: 13/52/31
EUT: Wifi Repeater	Engineer Signature:
Mode: TX Channel 1(802.11g)	Distance: 3m
Model: VRP150	
Manufacturer: HouTian	

Note: Report No.:ATE20131606

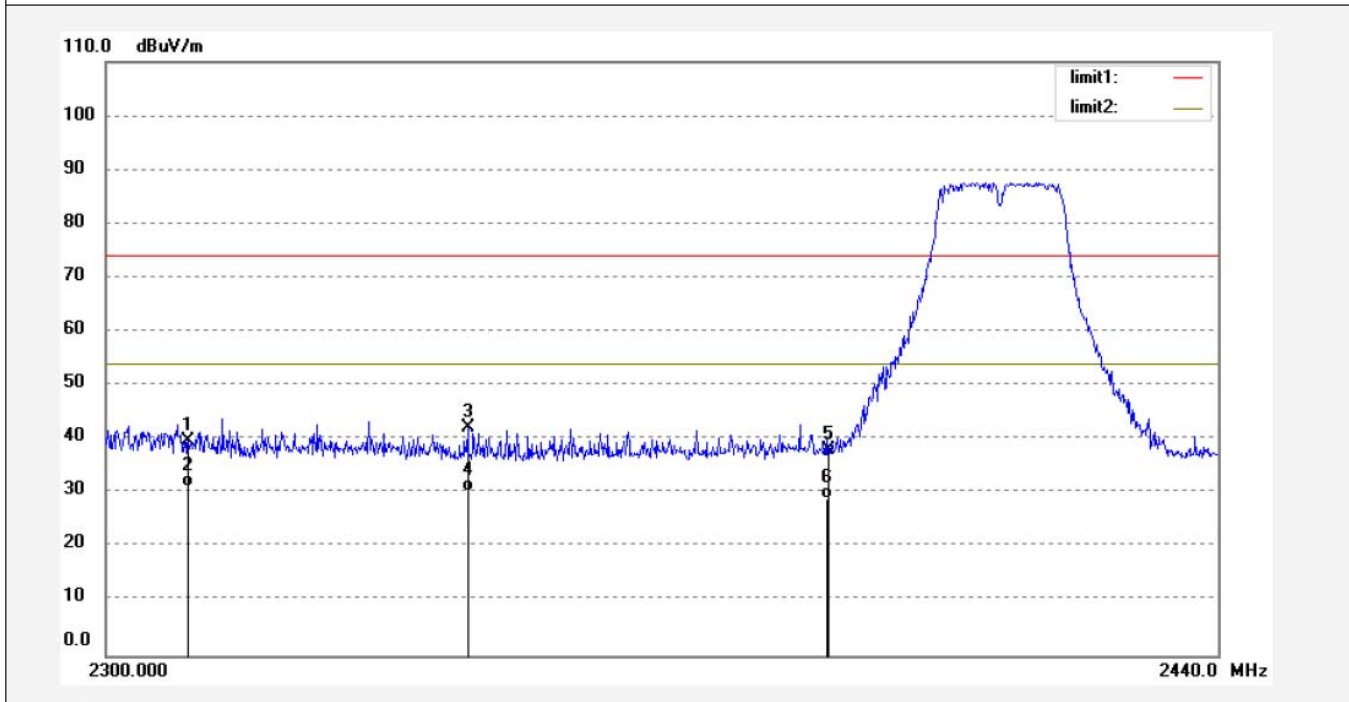

No.	Freq. (MHz)	Reading (dBuV/m)	Factor (dB)	Result (dBuV/m)	Limit (dBuV/m)	Margin (dB)	Detector	Height (cm)	Degree (deg.)	Remark
1	2310.000	47.47	-7.81	39.66	74.00	-34.34	peak			
2	2310.000	38.91	-7.81	31.10	54.00	-22.90	AVG			
3	2344.686	49.93	-7.79	42.14	74.00	-31.86	peak			
4	2344.686	38.22	-7.79	30.43	54.00	-23.57	AVG			
5	2390.000	45.66	-7.53	38.13	74.00	-35.87	peak			
6	2390.000	36.43	-7.53	28.90	54.00	-25.10	AVG			

**ACCURATE TECHNOLOGY CO., LTD.**

 F1,Bldg,A,Changyuan New Material Port Keyuan Rd,  
 Science & Industry Park,Nanshan Shenzhen,P.R.China

Site: 2# chamber

Tel:+86-0755-26503290

Fax:+86-0755-26503396

 Job No.: star #2907  
 Standard: FCC 15C PK  
 Test item: Radiation Test  
 Temp.( C)/Hum.(%) 23 C / 49 %  
 EUT: Wifi Repeater  
 Mode: TX Channel 1(802.11g)  
 Model: VRP150  
 Manufacturer: HouTian

 Polarization: Vertical  
 Power Source: DC 5V  
 Date: 13/07/25/  
 Time: 13/48/54  
 Engineer Signature:  
 Distance: 3m

Note: Report No.:ATE20131606

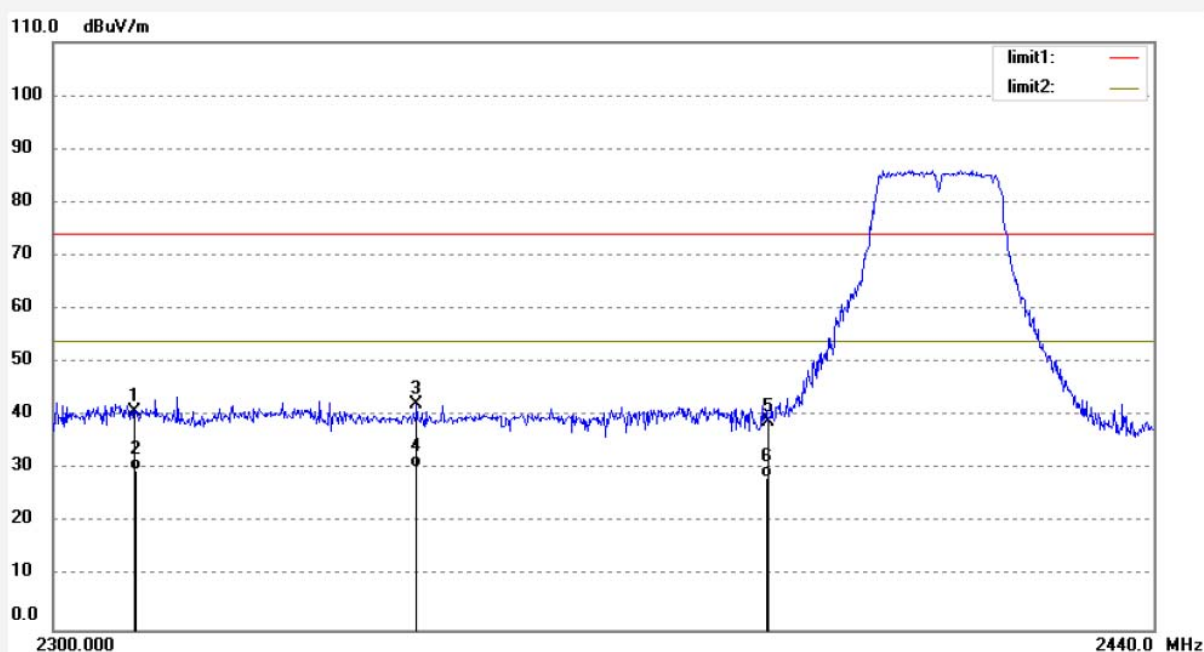

No.	Freq. (MHz)	Reading (dBuV/m)	Factor (dB)	Result (dBuV/m)	Limit (dBuV/m)	Margin (dB)	Detector	Height (cm)	Degree (deg.)	Remark
1	2310.000	48.53	-7.81	40.72	74.00	-33.28	peak			
2	2310.000	37.61	-7.81	29.80	54.00	-24.20	AVG			
3	2345.380	50.02	-7.79	42.23	74.00	-31.77	peak			
4	2345.380	38.29	-7.79	30.50	54.00	-23.50	AVG			
5	2390.000	46.54	-7.53	39.01	74.00	-34.99	peak			
6	2390.000	35.91	-7.53	28.38	54.00	-25.62	AVG			





**ACCURATE TECHNOLOGY CO., LTD.**

F1,Bldg,A,Changyuan New Material Port Keyuan Rd,  
Science & Industry Park,Nanshan Shenzhen,P.R.China

Site: 2# chamber  
Tel:+86-0755-26503290  
Fax:+86-0755-26503396

Job No.: star #2906	Polarization: Vertical
Standard: FCC 15C PK	Power Source: DC 5V
Test item: Radiation Test	Date: 13/07/25/
Temp.( C)/Hum.(%) 23 C / 49 %	Time: 13/44/42
EUT: Wifi Repeater	Engineer Signature:
Mode: TX Channel 11(802.11g)	Distance: 3m
Model: VRP150	
Manufacturer: HouTian	

Note: Report No.:ATE20131606

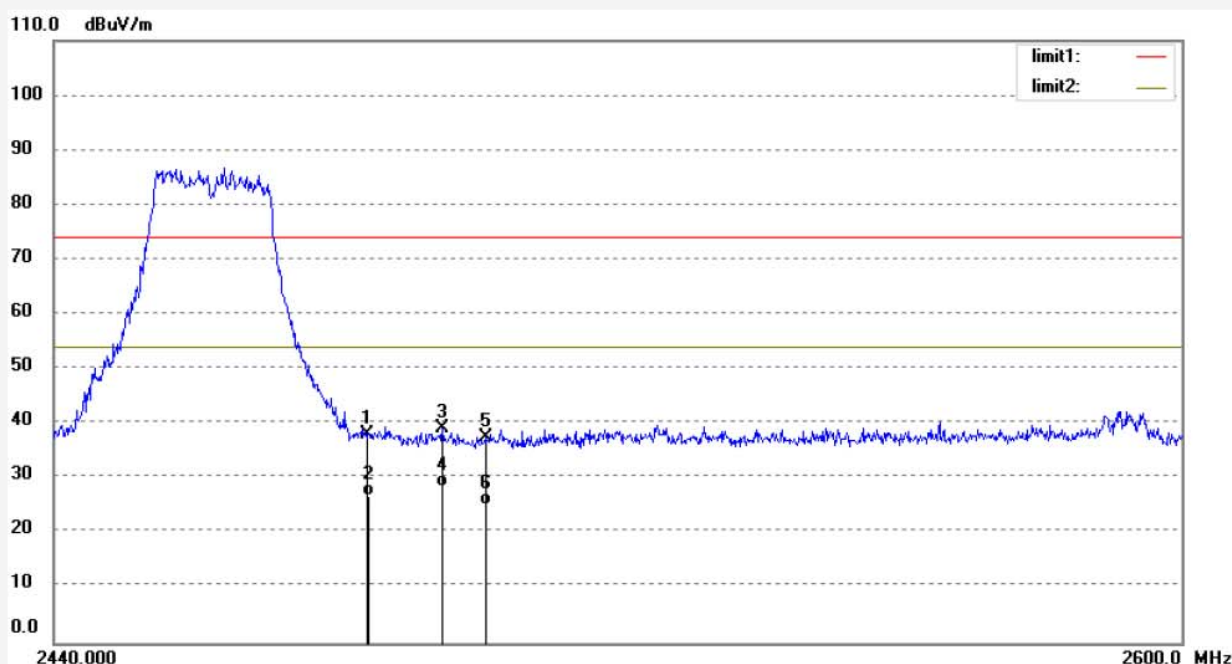

No.	Freq. (MHz)	Reading (dBuV/m)	Factor (dB)	Result (dBuV/m)	Limit (dBuV/m)	Margin (dB)	Detector	Height (cm)	Degree (deg.)	Remark
1	2483.500	45.47	-7.37	38.10	74.00	-35.90	peak			
2	2483.500	34.17	-7.37	26.80	54.00	-27.20	AVG			
3	2494.006	46.64	-7.40	39.24	74.00	-34.76	peak			
4	2494.006	35.91	-7.40	28.51	54.00	-25.49	AVG			
5	2500.000	44.82	-7.40	37.42	74.00	-36.58	peak			
6	2500.000	32.58	-7.40	25.18	54.00	-28.82	AVG			



**ACCURATE TECHNOLOGY CO., LTD.**

F1,Bldg,A,Changyuan New Material Port Keyuan Rd,  
Science & Industry Park,Nanshan Shenzhen,P.R.China

Site: 2# chamber  
Tel:+86-0755-26503290  
Fax:+86-0755-26503396

Job No.: star #2905	Polarization: Horizontal
Standard: FCC 15C PK	Power Source: DC 5V
Test item: Radiation Test	Date: 13/07/25/
Temp.( C)/Hum.(%) 23 C / 49 %	Time: 13/38/10
EUT: Wifi Repeater	Engineer Signature:
Mode: TX Channel 11(802.11g)	Distance: 3m
Model: VRP150	
Manufacturer: HouTian	

Note: Report No.:ATE20131606

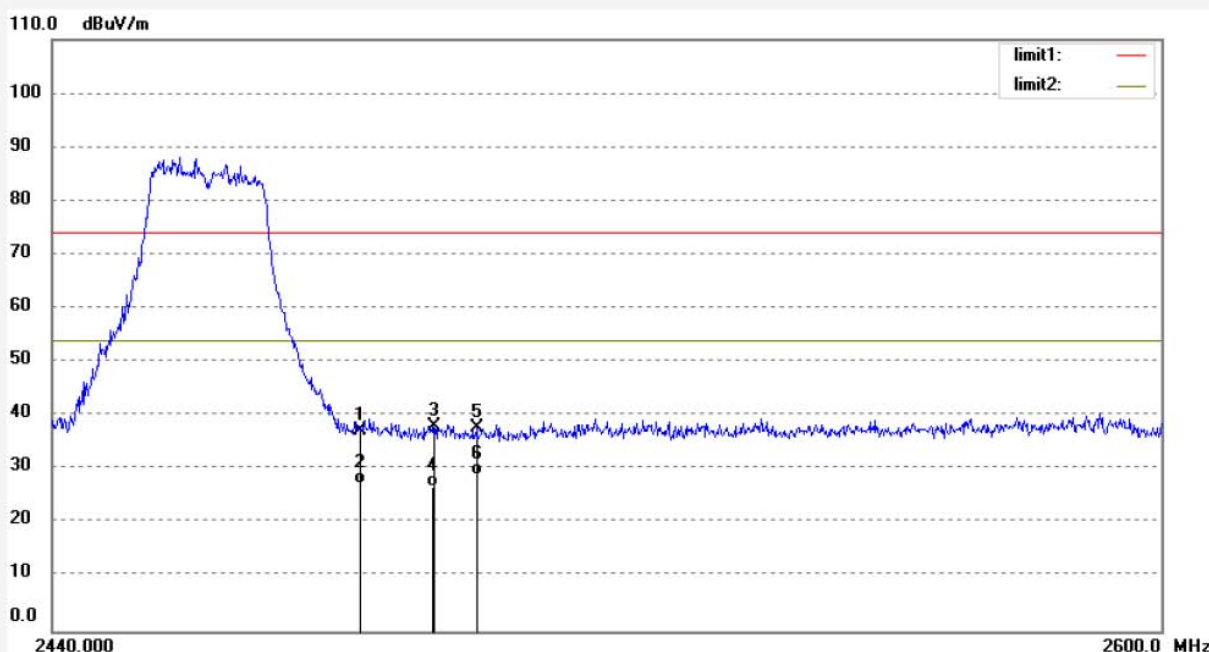

No.	Freq. (MHz)	Reading (dBuV/m)	Factor (dB)	Result (dBuV/m)	Limit (dBuV/m)	Margin (dB)	Detector	Height (cm)	Degree (deg.)	Remark
1	2483.500	44.50	-7.37	37.13	74.00	-36.87	peak			
2	2483.500	34.67	-7.37	27.30	54.00	-26.70	AVG			
3	2493.848	45.47	-7.40	38.07	74.00	-35.93	peak			
4	2493.848	34.19	-7.40	26.79	54.00	-27.21	AVG			
5	2500.000	45.21	-7.40	37.81	74.00	-36.19	peak			
6	2500.000	36.48	-7.40	29.08	54.00	-24.92	AVG			



**ACCURATE TECHNOLOGY CO., LTD.**

F1,Bldg,A,Changyuan New Material Port Keyuan Rd,  
Science & Industry Park,Nanshan Shenzhen,P.R.China

Site: 2# chamber  
Tel:+86-0755-26503290  
Fax:+86-0755-26503396

Job No.: star #2909  
Standard: FCC 15C PK  
Test item: Radiation Test  
Temp.( C)/Hum.(%) 23 C / 49 %  
EUT: Wifi Repeater  
Mode: TX Channel 1(802.11n)  
Model: VRP150  
Manufacturer: HouTian

Polarization: Horizontal  
Power Source: DC 5V  
Date: 13/07/25/  
Time: 13/58/23  
Engineer Signature:  
Distance: 3m

Note: Report No.:ATE20131606

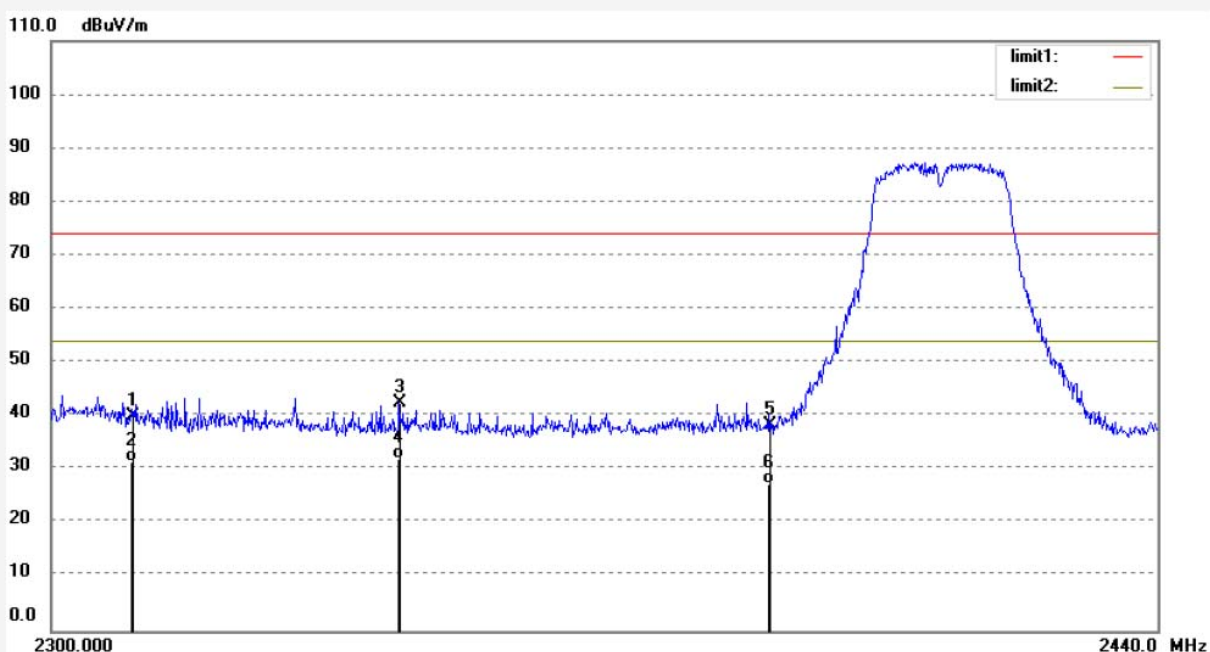

No.	Freq. (MHz)	Reading (dBuV/m)	Factor (dB)	Result (dBuV/m)	Limit (dBuV/m)	Margin (dB)	Detector	Height (cm)	Degree (deg.)	Remark
1	2310.000	47.88	-7.81	40.07	74.00	-33.93	peak			
2	2310.000	39.24	-7.81	31.43	54.00	-22.57	AVG			
3	2343.160	50.17	-7.79	42.38	74.00	-31.62	peak			
4	2343.160	39.88	-7.79	32.09	54.00	-21.91	AVG			
5	2390.000	45.76	-7.53	38.23	74.00	-35.77	peak			
6	2390.000	34.81	-7.53	27.28	54.00	-26.72	AVG			



**ACCURATE TECHNOLOGY CO., LTD.**

F1,Bldg,A,Changyuan New Material Port Keyuan Rd,  
Science & Industry Park,Nanshan Shenzhen,P.R.China

Site: 2# chamber  
Tel:+86-0755-26503290  
Fax:+86-0755-26503396

Job No.: star #2910	Polarization: Vertical
Standard: FCC 15C PK	Power Source: DC 5V
Test item: Radiation Test	Date: 13/07/25/
Temp.( C)/Hum.(%) 23 C / 49 %	Time: 14/03/14
EUT: Wifi Repeater	Engineer Signature:
Mode: TX Channel 1(802.11n)	Distance: 3m
Model: VRP150	
Manufacturer: HouTian	

Note: Report No.:ATE20131606

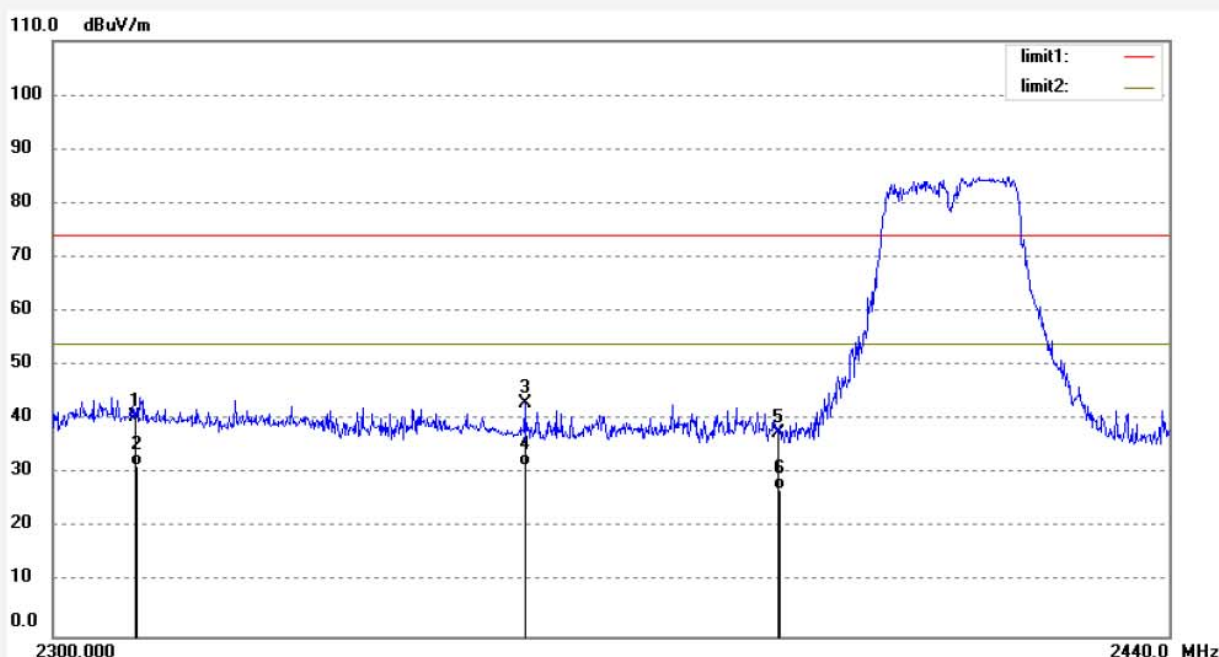

No.	Freq. (MHz)	Reading (dBuV/m)	Factor (dB)	Result (dBuV/m)	Limit (dBuV/m)	Margin (dB)	Detector	Height (cm)	Degree (deg.)	Remark
1	2310.000	48.26	-7.81	40.45	74.00	-33.55	peak			
2	2310.000	39.33	-7.81	31.52	54.00	-22.48	AVG			
3	2358.191	50.86	-7.74	43.12	74.00	-30.88	peak			
4	2358.191	39.36	-7.74	31.62	54.00	-22.38	AVG			
5	2390.000	44.94	-7.53	37.41	74.00	-36.59	peak			
6	2390.000	34.58	-7.53	27.05	54.00	-26.95	AVG			



**ACCURATE TECHNOLOGY CO., LTD.**

F1,Bldg,A,Changyuan New Material Port Keyuan Rd,  
Science & Industry Park,Nanshan Shenzhen,P.R.China

Site: 2# chamber  
Tel:+86-0755-26503290  
Fax:+86-0755-26503396

Job No.: star #2911  
Standard: FCC 15C PK  
Test item: Radiation Test  
Temp.( C)/Hum.(%) 23 C / 49 %  
EUT: Wifi Repeater  
Mode: TX Channel 11(802.11n)  
Model: VRP150  
Manufacturer: HouTian

Polarization: Vertical  
Power Source: DC 5V  
Date: 13/07/25/  
Time: 14/10/25  
Engineer Signature:  
Distance: 3m

Note: Report No.:ATE20131606

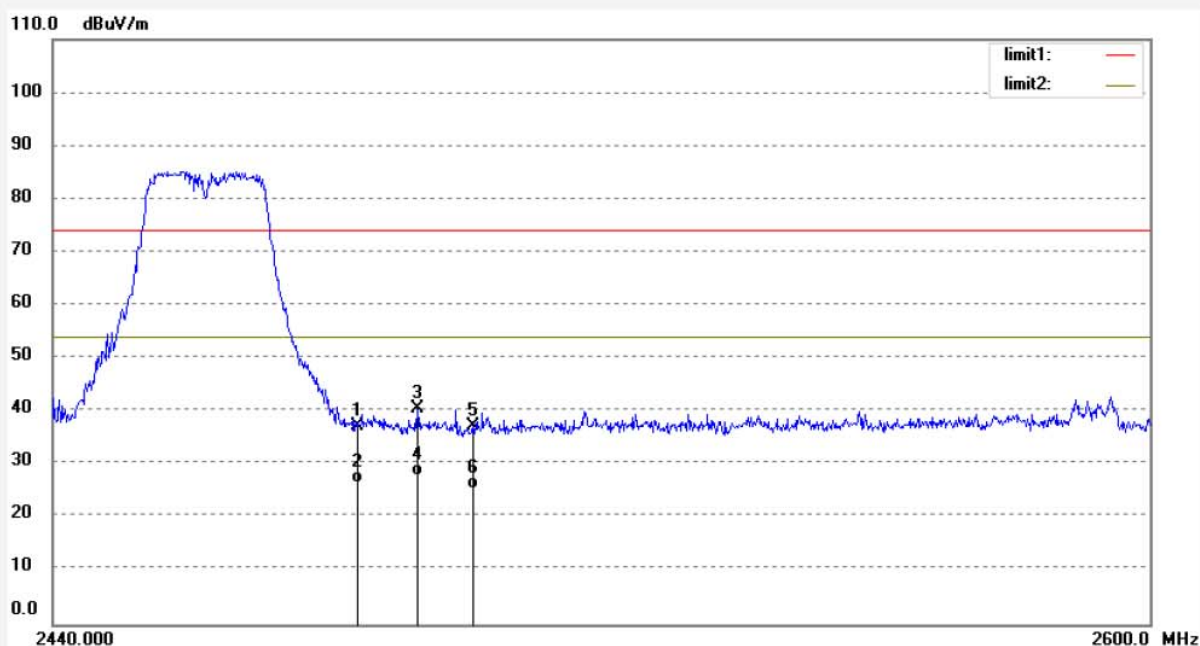

No.	Freq. (MHz)	Reading (dBuV/m)	Factor (dB)	Result (dBuV/m)	Limit (dBuV/m)	Margin (dB)	Detector	Height (cm)	Degree (deg.)	Remark
1	2483.500	44.77	-7.37	37.40	74.00	-36.60	peak			
2	2483.500	33.80	-7.37	26.43	54.00	-27.57	AVG			
3	2492.102	48.02	-7.39	40.63	74.00	-33.37	peak			
4	2492.102	35.17	-7.39	27.78	54.00	-26.22	AVG			
5	2500.000	44.65	-7.40	37.25	74.00	-36.75	peak			
6	2500.000	32.93	-7.40	25.53	54.00	-28.47	AVG			



**ACCURATE TECHNOLOGY CO., LTD.**

F1,Bldg,A,Changyuan New Material Port Keyuan Rd,  
Science & Industry Park,Nanshan Shenzhen,P.R.China

Site: 2# chamber  
Tel:+86-0755-26503290  
Fax:+86-0755-26503396

Job No.: star #2912	Polarization: Horizontal
Standard: FCC 15C PK	Power Source: DC 5V
Test item: Radiation Test	Date: 13/07/25/
Temp.( C)/Hum.(%) 23 C / 49 %	Time: 14/15/12
EUT: Wifi Repeater	Engineer Signature:
Mode: TX Channel 11(802.11n)	Distance: 3m
Model: VRP150	
Manufacturer: HouTian	

Note: Report No.:ATE20131606

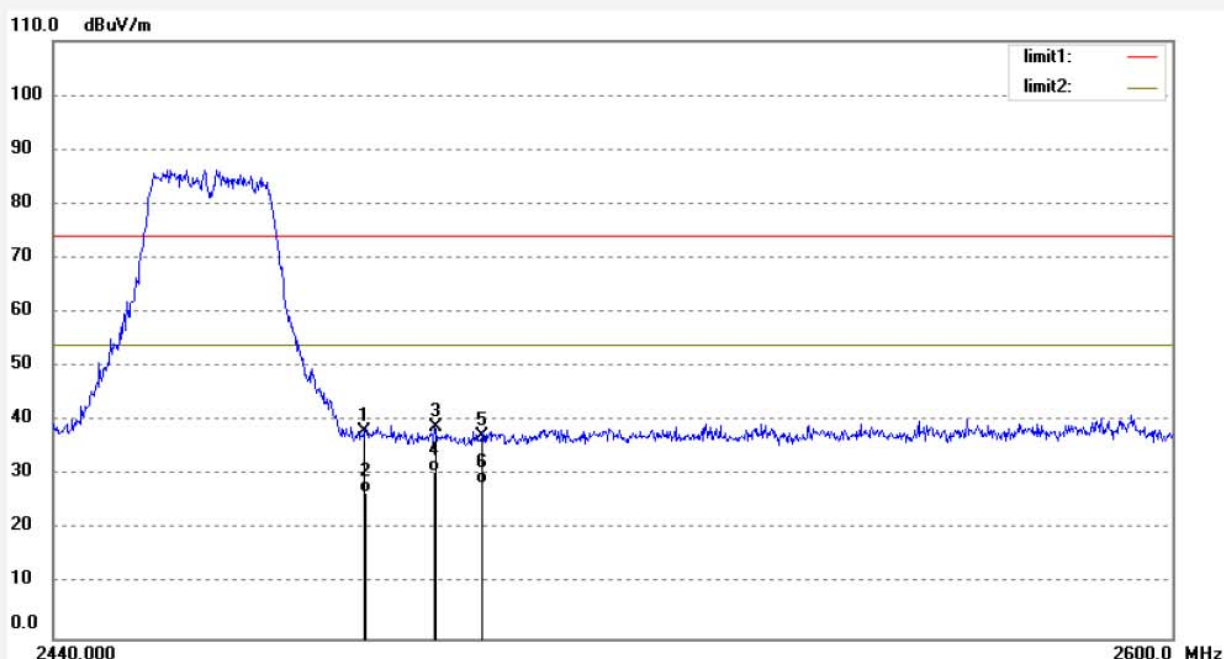

No.	Freq. (MHz)	Reading (dBuV/m)	Factor (dB)	Result (dBuV/m)	Limit (dBuV/m)	Margin (dB)	Detector	Height (cm)	Degree (deg.)	Remark
1	2483.500	45.40	-7.37	38.03	74.00	-35.97	peak			
2	2483.500	34.28	-7.37	26.91	54.00	-27.09	AVG			
3	2493.372	46.17	-7.39	38.78	74.00	-35.22	peak			
4	2493.372	37.92	-7.39	30.53	54.00	-23.47	AVG			
5	2500.000	44.68	-7.40	37.28	74.00	-36.72	peak			
6	2500.000	35.91	-7.40	28.51	54.00	-25.49	AVG			



**ACCURATE TECHNOLOGY CO., LTD.**

F1,Bldg,A,Changyuan New Material Port Keyuan Rd,  
Science & Industry Park,Nanshan Shenzhen,P.R.China

Site: 2# chamber  
Tel:+86-0755-26503290  
Fax:+86-0755-26503396

Job No.: star #2916	Polarization: Horizontal
Standard: FCC 15C PK	Power Source: DC 5V
Test item: Radiation Test	Date: 13/07/25/
Temp.( C)/Hum.(%) 23 C / 49 %	Time: 14/39/42
EUT: Wifi Repeater	Engineer Signature:
Mode: TX Channel 3(802.11n)40MHz	Distance: 3m
Model: VRP150	
Manufacturer: HouTian	

Note: Report No.:ATE20131606

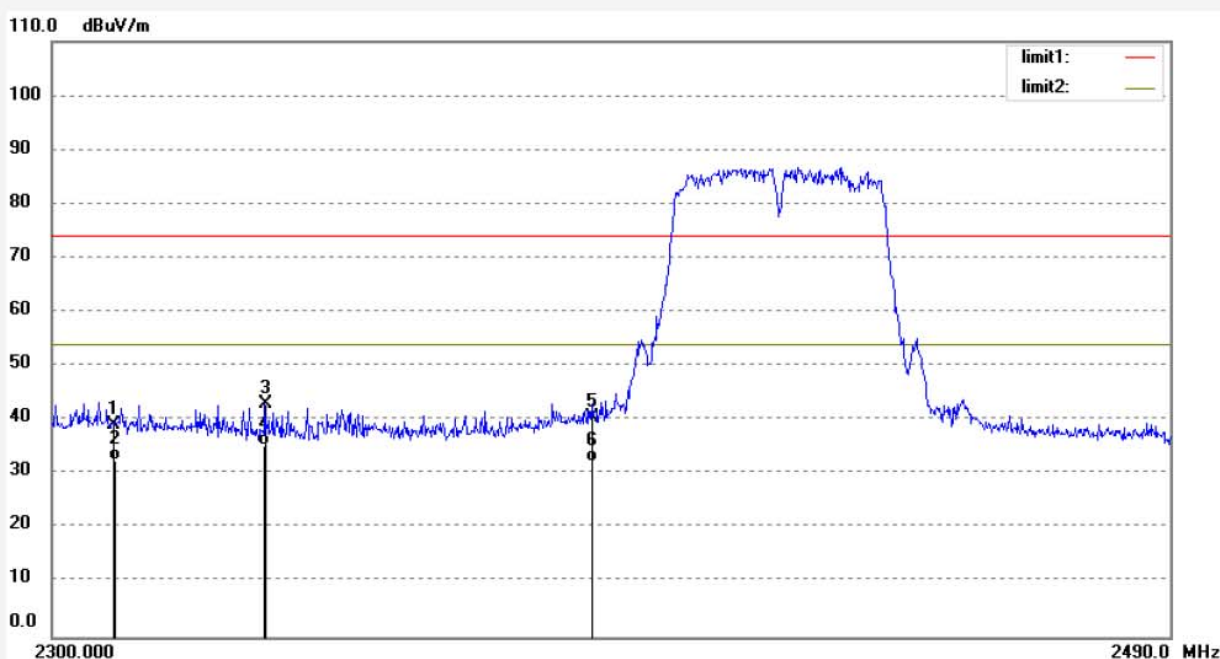

No.	Freq. (MHz)	Reading (dBuV/m)	Factor (dB)	Result (dBuV/m)	Limit (dBuV/m)	Margin (dB)	Detector	Height (cm)	Degree (deg.)	Remark
1	2310.000	47.08	-7.81	39.27	74.00	-34.73	peak			
2	2310.000	40.28	-7.81	32.47	54.00	-21.53	AVG			
3	2335.020	50.71	-7.80	42.91	74.00	-31.09	peak			
4	2335.020	43.17	-7.80	35.37	54.00	-18.63	AVG			
5	2390.000	47.97	-7.53	40.44	74.00	-33.56	peak			
6	2390.000	39.83	-7.53	32.30	54.00	-21.70	AVG			



**ACCURATE TECHNOLOGY CO., LTD.**

F1,Bldg,A,Changyuan New Material Port Keyuan Rd,  
Science & Industry Park,Nanshan Shenzhen,P.R.China

Site: 2# chamber  
Tel:+86-0755-26503290  
Fax:+86-0755-26503396

Job No.: star #2915	Polarization: Vertical
Standard: FCC 15C PK	Power Source: DC 5V
Test item: Radiation Test	Date: 13/07/25/
Temp.( C)/Hum.(%) 23 C / 49 %	Time: 14/33/52
EUT: Wifi Repeater	Engineer Signature:
Mode: TX Channel 3(802.11n)40MHz	Distance: 3m
Model: VRP150	
Manufacturer: HouTian	

Note: Report No.:ATE20131606

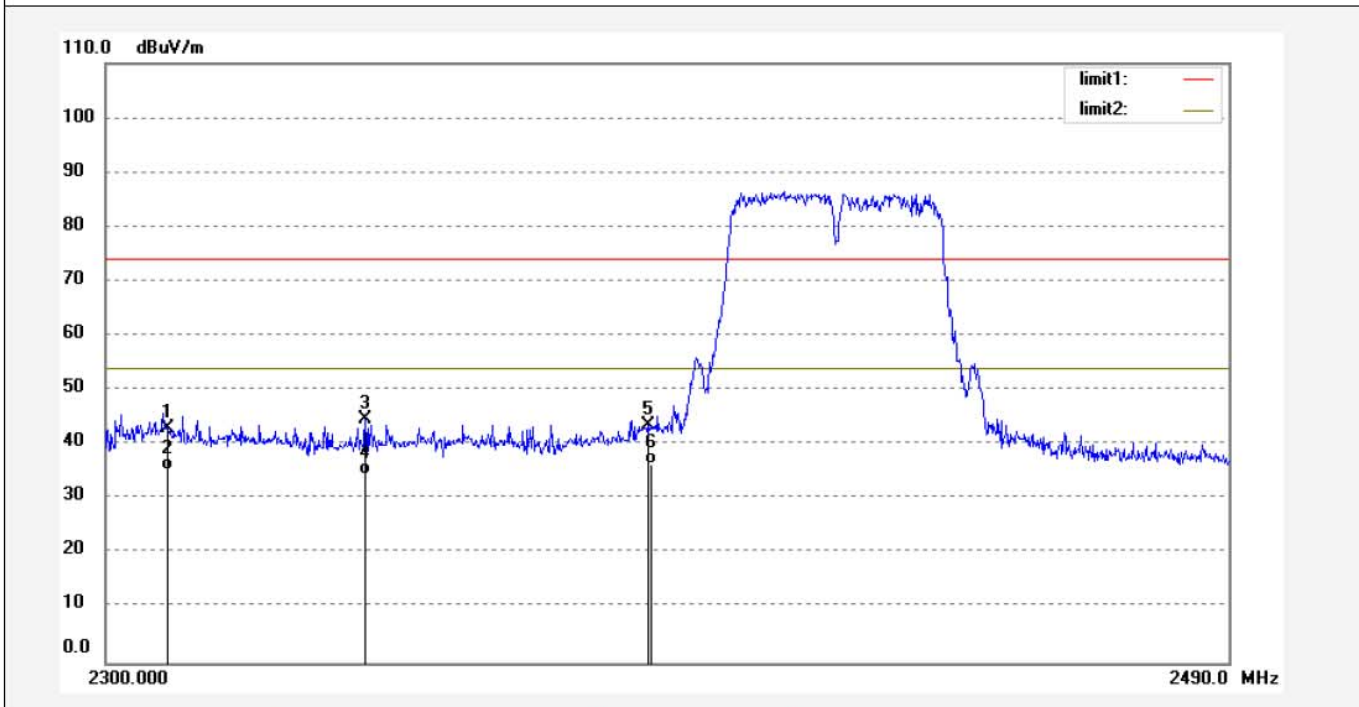

No.	Freq. (MHz)	Reading (dBuV/m)	Factor (dB)	Result (dBuV/m)	Limit (dBuV/m)	Margin (dB)	Detector	Height (cm)	Degree (deg.)	Remark
1	2310.000	50.94	-7.81	43.13	74.00	-30.87	peak			
2	2310.000	43.08	-7.81	35.27	54.00	-18.73	AVG			
3	2342.646	52.49	-7.79	44.70	74.00	-29.30	peak			
4	2342.646	42.18	-7.79	34.39	54.00	-19.61	AVG			
5	2390.000	51.17	-7.53	43.64	74.00	-30.36	peak			
6	2390.000	43.99	-7.53	36.46	54.00	-17.54	AVG			



**ACCURATE TECHNOLOGY CO., LTD.**

 F1,Bldg,A,Changyuan New Material Port Keyuan Rd,  
 Science & Industry Park,Nanshan Shenzhen,P.R.China

 Site: 2# chamber  
 Tel:+86-0755-26503290  
 Fax:+86-0755-26503396

Job No.: star #2914

Standard: FCC 15C PK

Test item: Radiation Test

Temp.( C)/Hum.(%) 23 C / 49 %

EUT: Wifi Repeater

Mode: TX Channel 9(802.11n)40MHz

Model: VRP150

Manufacturer: HouTian

Polarization: Vertical

Power Source: DC 5V

Date: 13/07/25/

Time: 14/27/55

Engineer Signature:

Distance: 3m

Note: Report No.:ATE20131606

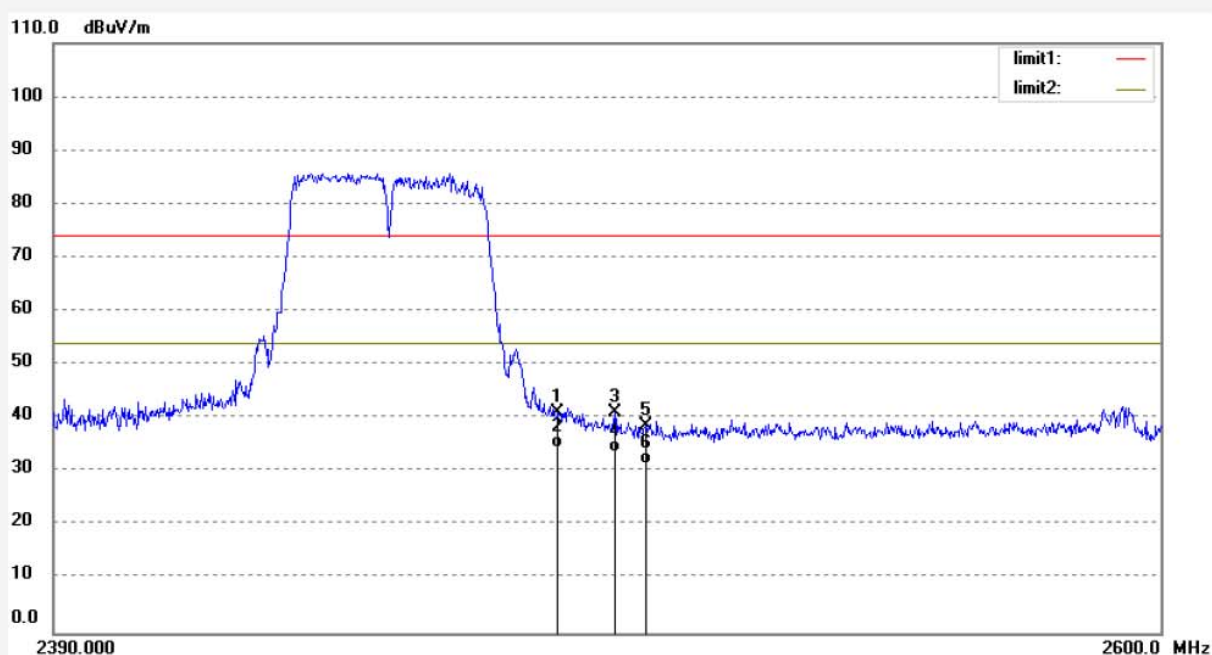

No.	Freq. (MHz)	Reading (dBuV/m)	Factor (dB)	Result (dBuV/m)	Limit (dBuV/m)	Margin (dB)	Detector	Height (cm)	Degree (deg.)	Remark
1	2483.500	48.40	-7.37	41.03	74.00	-32.97	peak			
2	2483.500	41.89	-7.37	34.52	54.00	-19.48	AVG			
3	2494.262	48.52	-7.39	41.13	74.00	-32.87	peak			
4	2494.262	41.00	-7.39	33.61	54.00	-20.39	AVG			
5	2500.000	46.08	-7.40	38.68	74.00	-35.32	peak			
6	2500.000	38.91	-7.40	31.51	54.00	-22.49	AVG			



**ACCURATE TECHNOLOGY CO., LTD.**

F1,Bldg,A,Changyuan New Material Port Keyuan Rd,  
Science & Industry Park,Nanshan Shenzhen,P.R.China

Site: 2# chamber  
Tel:+86-0755-26503290  
Fax:+86-0755-26503396

Job No.: star #2913	Polarization: Horizontal
Standard: FCC 15C PK	Power Source: DC 5V
Test item: Radiation Test	Date: 13/07/25/
Temp.( C)/Hum.(%) 23 C / 49 %	Time: 14/21/19
EUT: Wifi Repeater	Engineer Signature:
Mode: TX Channel 9(802.11n)40MHz	Distance: 3m
Model: VRP150	
Manufacturer: HouTian	

Note: Report No.:ATE20131606

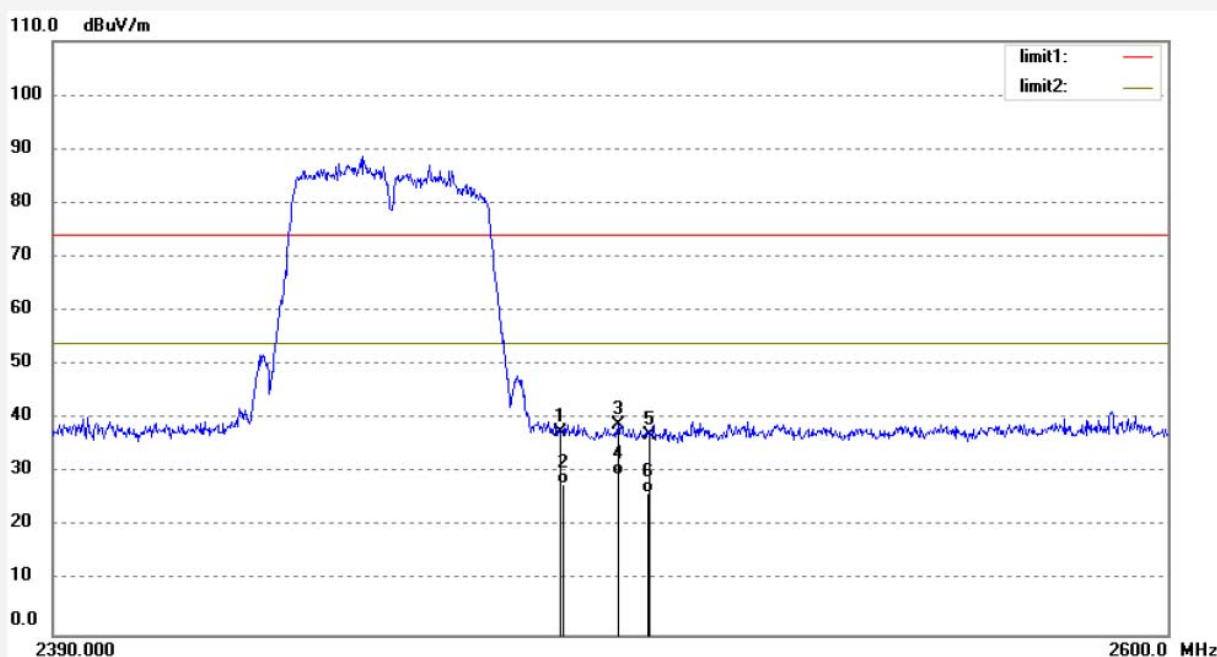

No.	Freq. (MHz)	Reading (dBuV/m)	Factor (dB)	Result (dBuV/m)	Limit (dBuV/m)	Margin (dB)	Detector	Height (cm)	Degree (deg.)	Remark
1	2483.500	44.87	-7.37	37.50	74.00	-36.50	peak			
2	2483.500	35.17	-7.37	27.80	54.00	-26.20	AVG			
3	2494.262	46.29	-7.39	38.90	74.00	-35.10	peak			
4	2494.262	36.99	-7.39	29.60	54.00	-24.40	AVG			
5	2500.000	44.48	-7.40	37.08	74.00	-36.92	peak			
6	2500.000	33.55	-7.40	26.15	54.00	-27.85	AVG			

## 9. RADIATED SPURIOUS EMISSION TEST

### 9.1. Block Diagram of Test Setup

#### 9.1.1. Block diagram of connection between the EUT and peripherals

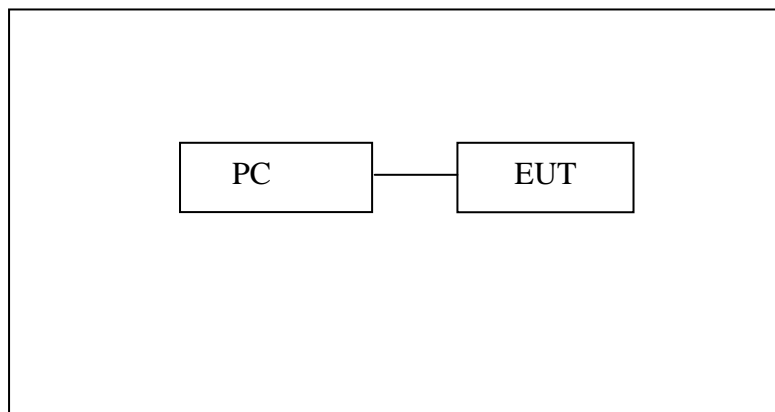

Setup: Transmitting mode

(EUT: Wifi Repeater)

#### 9.1.2. Semi-Anechoic Chamber Test Setup Diagram

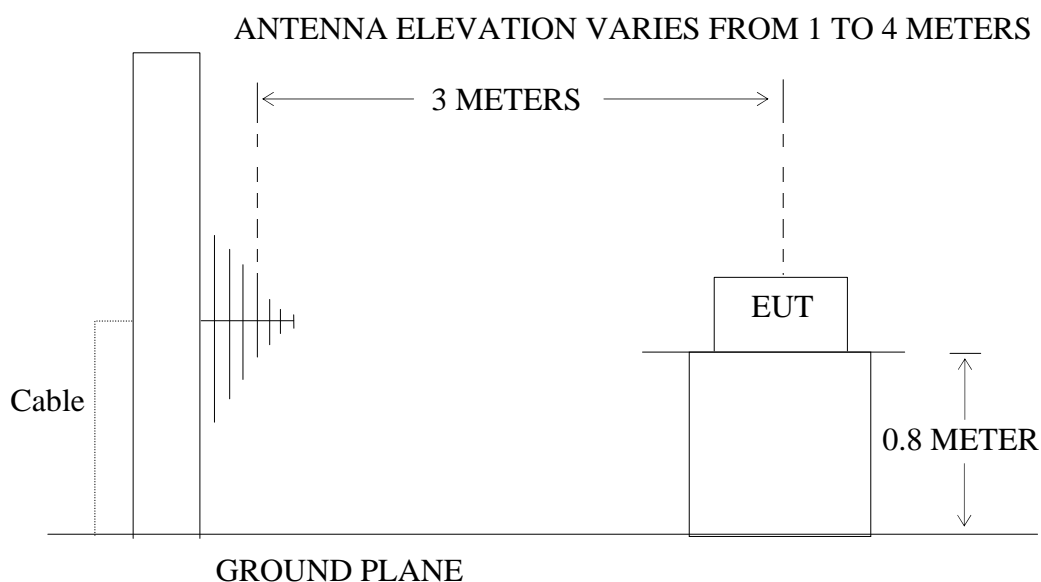

(EUT: Wifi Repeater)

## 9.2.The Limit For Section 15.247(d)

Section 15.247(d): In any 100 kHz bandwidth outside the frequency band in which the spread spectrum or digitally modulated intentional radiator is operating, the radio frequency power that is produced by the intentional radiator shall be at least 20 dB below that in the 100 kHz bandwidth within the band that contains the highest level of the desired power, based on either an RF conducted or a radiated measurement, provided the transmitter demonstrates compliance with the peak conducted power limits. If the transmitter complies with the conducted power limits based on the use of RMS averaging over a time interval, as permitted under paragraph (b)(3) of this section, the attenuation required under this paragraph shall be 30 dB instead of 20 dB. Attenuation below the general limits specified in Section 15.209(a) is not required. In addition, radiated emissions which fall in the restricted bands, as defined in Section 15.205(a), must also comply with the radiated emission limits specified in Section 15.209(a).

## 9.3.Restricted bands of operation

### 9.3.1.FCC Part 15.205 Restricted bands of operation

(a) Except as shown in paragraph (d) of this section, Only spurious emissions are permitted in any of the frequency bands listed below:

MHz	MHz	MHz	GHz
0.090-0.110	16.42-16.423	399.9-410	4.5-5.15
<sup>1</sup> 0.495-0.505	16.69475-16.69525	608-614	5.35-5.46
2.1735-2.1905	16.80425-16.80475	960-1240	7.25-7.75
4.125-4.128	25.5-25.67	1300-1427	8.025-8.5
4.17725-4.17775	37.5-38.25	1435-1626.5	9.0-9.2
4.20725-4.20775	73-74.6	1645.5-1646.5	9.3-9.5
6.215-6.218	74.8-75.2	1660-1710	10.6-12.7
6.26775-6.26825	108-121.94	1718.8-1722.2	13.25-13.4
6.31175-6.31225	123-138	2200-2300	14.47-14.5
8.291-8.294	149.9-150.05	2310-2390	15.35-16.2
8.362-8.366	156.52475-156.52525	2483.5-2500	17.7-21.4
8.37625-8.38675	156.7-156.9	2690-2900	22.01-23.12
8.41425-8.41475	162.0125-167.17	3260-3267	23.6-24.0
12.29-12.293	167.72-173.2	3332-3339	31.2-31.8
12.51975-12.52025	240-285	3345.8-3358	36.43-36.5
12.57675-12.57725	322-335.4	3600-4400	( <sup>2</sup> )
13.36-13.41			

<sup>1</sup>Until February 1, 1999, this restricted band shall be 0.490-0.510

<sup>2</sup>Above 38.6

(b) Except as provided in paragraphs (d) and (e), the field strength of emission appearing within these frequency bands shall not exceed the limits shown in Section 15.209. At frequencies equal to or less than 1000MHz, Compliance with the limits in Section 15.209 shall be demonstrated using measurement instrumentation employing a CISPR quasi-peak detector. Above 1000MHz, compliance with the emission limits in Section 15.209 shall be demonstrated based on the average value of the measured emissions. The provisions in Section 15.35 apply to these measurements.

## 9.4. Configuration of EUT on Measurement

The following equipment are installed on Radiated Emission Measurement to meet the commission requirements and operating regulations in a manner which tends to maximize its emission characteristics in normal application.

### 9.4.1. Wifi Repeater (EUT)

Model Number : VRP150  
 Serial Number : N/A  
 Manufacturer : Shenzhen HouTian Network Communication  
 Technology Co., Ltd

## 9.5. Operating Condition of EUT

9.5.1. Setup the EUT and simulator as shown as Section 9.1.

9.5.2. Turn on the power of all equipment.

9.5.3. Let the EUT work in TX modes measure it. The transmit frequency are 2412-2462 and 2422-2452MHz. We select 2412MHz, 2437MHz, 2462MHz and 2422MHz, 2437MHz, 2452MHz TX frequency to transmit.

## 9.6. Test Procedure

The EUT and its simulators are placed on a turntable, which is 0.8 meter high above ground. The turntable can rotate 360 degrees to determine the position of the maximum emission level. EUT is set 3.0 meters away from the receiving antenna, which is mounted on an antenna tower. The antenna can be moved up and down between 1.0 meter and 4 meters to find out the maximum emission level. Broadband antenna (calibrated bilog antenna) is used as receiving antenna. Both horizontal and vertical polarizations of the antenna are set on measurement. In order to find the maximum emission levels, all of the interface cables must be manipulated according to ANSI C63.4-2009 on radiated emission measurement. The EUT was tested in 3 orthogonal planes.

The worst-case data rate for this channel to be 1Mbps for 802.11b mode and 6Mbps for 802.11g mode and 150Mbps for 802.11n mode, based on previous with 802.11 WLAN product design architectures.

The bandwidth of test receiver is set at 9kHz in below 30MHz. and set at 120kHz in 30-1000MHz, and 1MHz in above 1000MHz.

The frequency range from 9kHz to 25GHz is checked.

The final measurement in band 9-90kHz, 110-490kHz and above 1000MHz is performed with Average detector. Except those frequency bands mention above, the final measurement for frequencies below 1000MHz is performed with Quasi Peak detector.

The field strength is calculated by adding the antenna factor, and cable loss, and subtracting the amplifier gain from the measured reading. The basic equation calculation is as follows:

Result = Reading + Corrected Factor

Where Corrected Factor = Antenna Factor + Cable Loss – Amplifier Gain

## 9.7. The Field Strength of Radiation Emission Measurement Results

**PASS.**

Date of Test:	July 25, 2013	Temperature:	25°C
EUT:	Wifi Repeater	Humidity:	50%
Model No.:	VRP150	Power Supply:	AC120V/60Hz
Test Mode:	802.11b Channel Low 2412MHz	Test Engineer:	Star

### For 30MHz-1000MHz

Corrected Factor = Antenna Factor + Cable Loss – Amplifier Gain

Frequency (MHz)	Reading (dBμV/m)		Factor Corr. (dB)	Result (dBμV/m)		Limit (dBμV/m)	Margin (dB)		Polarization
	QP			QP	QP		QP	QP	
601.4265	47.56		-11.65	35.91		46.50		-10.59	Vertical
721.7259	50.31		-9.28	41.03		46.50		-5.47	
929.0082	46.15		-5.70	40.45		46.50		-6.05	
360.4476	55.98		-15.92	40.06		46.50		-6.44	Horizontal
721.7259	54.25		-9.28	44.97		46.50		-1.53	
842.1295	47.92		-7.10	40.82		46.50		-5.68	

### For 1GHz-25GHz

Corrected Factor = Antenna Factor + Cable Loss – Amplifier Gain

Frequency (MHz)	Reading(dBμV/m)		Factor Corr. (dB)	Result(dBμV/m)		Limit(dBμV/m)		Margin(dBμV/m)		Polarization
	AV	PEAK		AV	PEAK	AV	PEAK	AV	PEAK	
-	-	-	-	-	-	-	-	-	-	Vertical
-	-	-	-	-	-	-	-	-	-	Horizontal

**Note: 1. Emissions attenuated more than 20 dB below the permissible value are not reported.**

**2. \*: Denotes restricted band of operation.**

**3. The fundamental radiated emissions were reduced by Band Reject Filter in the attached plots.**

Date of Test:	July 25, 2013	Temperature:	25°C
EUT:	Wifi Repeater	Humidity:	50%
Model No.:	VRP150	Power Supply:	AC120V/60Hz
Test Mode:	802.11b Channel Middle 2437MHz	Test Engineer:	Star

**For 30MHz-1000MHz**

Corrected Factor = Antenna Factor + Cable Loss – Amplifier Gain

Frequency (MHz)	Reading (dBμV/m)		Factor Corr. (dB)	Result (dBμV/m)		Limit (dBμV/m)	Margin (dB)		Polarization
	QP			QP	QP		QP	QP	
601.4265	47.24		-11.65	35.59		46.50	-10.91		Vertical
721.7259	50.46		-9.28	41.18		46.50	-5.32		
842.1295	43.02		-7.10	35.92		46.50	-10.58		
360.4476	56.97		-15.92	41.05		46.50	-5.45		Horizontal
721.7259	53.97		-9.28	44.69		46.50	-1.81		
842.1296	48.08		-7.10	40.98		46.50	-5.52		

**For 1GHz-25GHz**

Corrected Factor = Antenna Factor + Cable Loss – Amplifier Gain

Frequency (MHz)	Reading(dBμV/m)		Factor Corr. (dB)	Result(dBμV/m)		Limit(dBμV/m)		Margin(dBμV/m)		Polarization
	AV	PEAK		AV	PEAK	AV	PEAK	AV	PEAK	
-	-	-	-	-	-	-	-	-	-	Vertical
-	-	-	-	-	-	-	-	-	-	Horizontal

**Note: 1. Emissions attenuated more than 20 dB below the permissible value are not reported.**

**2. \*: Denotes restricted band of operation.**

**3. The fundamental radiated emissions were reduced by Band Reject Filter in the attached plots.**

Date of Test:	July 25, 2013	Temperature:	25°C
EUT:	Wifi Repeater	Humidity:	50%
Model No.:	VRP150	Power Supply:	AC120V/60Hz
Test Mode:	802.11b Channel High 2462MHz	Test Engineer:	Star

**For 30MHz-1000MHz**

Corrected Factor = Antenna Factor + Cable Loss – Amplifier Gain

Frequency (MHz)	Reading (dBμV/m)		Factor Corr. (dB)	Result (dBμV/m)		Limit (dBμV/m)	Margin (dB)		Polarization
	QP			QP	QP		QP	QP	
601.4265	46.74		-11.65	35.09		46.50	-11.41		Vertical
721.7259	50.33		-9.28	41.05		46.50	-5.45		
842.1295	42.59		-7.10	35.48		46.50	-11.02		
360.4476	57.13		-15.92	41.21		46.50	-5.29		Horizontal
721.7259	54.11		-9.28	44.83		46.50	-1.67		
842.1295	48.43		-7.10	41.33		46.50	-5.17		

**For 1GHz-25GHz**

Corrected Factor = Antenna Factor + Cable Loss – Amplifier Gain

Frequency (MHz)	Reading(dBμV/m)		Factor Corr. (dB)	Result(dBμV/m)		Limit(dBμV/m)		Margin(dBμV/m)		Polarization
	AV	PEAK		AV	PEAK	AV	PEAK	AV	PEAK	
-	-	-	-	-	-	-	-	-	-	Vertical
-	-	-	-	-	-	-	-	-	-	Horizontal

**Note: 1. Emissions attenuated more than 20 dB below the permissible value are not reported.**

**2. \*: Denotes restricted band of operation.**

**3. The fundamental radiated emissions were reduced by Band Reject Filter in the attached plots.**



Date of Test:	July 25, 2013	Temperature:	25°C
EUT:	Wifi Repeater	Humidity:	50%
Model No.:	VRP150	Power Supply:	AC120V/60Hz
Test Mode:	802.11g Channel Low 2412MHz	Test Engineer:	Star

**For 30MHz-1000MHz**

Corrected Factor = Antenna Factor + Cable Loss – Amplifier Gain

Frequency (MHz)	Reading (dBμV/m)	Factor Corr. (dB)	Result (dBμV/m)	Limit (dBμV/m)	Margin (dB)	Polarization
	QP		QP	QP	QP	
601.4265	47.05	-11.65	35.40	46.50	-11.10	Vertical
721.7259	50.06	-9.28	40.78	46.50	-5.72	
842.1295	42.93	-7.10	35.83	46.50	-10.67	
360.4476	57.04	-15.92	41.12	46.50	-5.38	Horizontal
721.7259	54.19	-9.28	44.91	46.50	-1.59	
842.1296	50.73	-7.10	43.63	46.50	-2.87	

**For 1GHz-25GHz**

Corrected Factor = Antenna Factor + Cable Loss – Amplifier Gain

Frequency (MHz)	Reading(dBμV/m)		Factor Corr. (dB)	Result(dBμV/m)		Limit(dBμV/m)		Margin(dBμV/m)		Polarization
	AV	PEAK		AV	PEAK	AV	PEAK	AV	PEAK	
-	-	-	-	-	-	-	-	-	-	Vertical
-	-	-	-	-	-	-	-	-	-	Horizontal

**Note: 1. Emissions attenuated more than 20 dB below the permissible value are not reported.**

**2. \*: Denotes restricted band of operation.**

**3. The fundamental radiated emissions were reduced by Band Reject Filter in the attached plots.**

Date of Test:	July 25, 2013	Temperature:	25°C
EUT:	Wifi Repeater	Humidity:	50%
Model No.:	VRP150	Power Supply:	AC120V/60Hz
Test Mode:	802.11g Channel Middle 2437MHz	Test Engineer:	Star

**For 30MHz-1000MHz**

Corrected Factor = Antenna Factor + Cable Loss – Amplifier Gain

Frequency (MHz)	Reading (dBμV/m)	Factor Corr. (dB)	Result (dBμV/m)	Limit (dBμV/m)	Margin (dB)	Polarization
	QP		QP	QP	QP	
601.4265	46.52	-11.65	34.87	46.50	-11.63	Vertical
721.7259	50.05	-9.28	40.77	46.50	-5.73	
842.1295	43.42	-7.10	36.32	46.50	-10.18	
360.4476	57.21	-15.92	41.29	46.50	-5.21	Horizontal
721.7259	54.03	-9.28	44.75	46.50	-1.75	
842.1295	51.31	-7.10	44.21	46.50	-2.29	

**For 1GHz-25GHz**

Corrected Factor = Antenna Factor + Cable Loss – Amplifier Gain

Frequency (MHz)	Reading(dBμV/m)		Factor Corr. (dB)	Result(dBμV/m)		Limit(dBμV/m)		Margin(dBμV/m)		Polarization
	AV	PEAK		AV	PEAK	AV	PEAK	AV	PEAK	
-	-	-	-	-	-	-	-	-	-	Vertical
-	-	-	-	-	-	-	-	-	-	Horizontal

**Note: 1. Emissions attenuated more than 20 dB below the permissible value are not reported.**

**2. \*: Denotes restricted band of operation.**

**3. The fundamental radiated emissions were reduced by Band Reject Filter in the attached plots.**

Date of Test:	July 25, 2013	Temperature:	25°C
EUT:	Wifi Repeater	Humidity:	50%
Model No.:	VRP150	Power Supply:	AC120V/60Hz
Test Mode:	802.11g Channel High 2462MHz	Test Engineer:	Star

**For 30MHz-1000MHz**

Corrected Factor = Antenna Factor + Cable Loss – Amplifier Gain

Frequency (MHz)	Reading (dBμV/m)		Factor Corr. (dB)	Result (dBμV/m)		Limit (dBμV/m)	Margin (dB)		Polarization
	QP			QP	QP		QP	QP	
601.4265	46.38		-11.65	34.73		46.50	-11.77		Vertical
721.7259	49.85		-9.28	40.57		46.50	-5.93		
842.1295	43.39		-7.10	36.29		46.50	-10.21		
360.4476	56.98		-15.92	41.06		46.50	-5.44		Horizontal
721.7259	54.18		-9.28	44.90		46.50	-1.60		
842.1296	50.47		-7.10	43.37		46.50	-3.13		

**For 1GHz-25GHz**

Corrected Factor = Antenna Factor + Cable Loss – Amplifier Gain

Frequency (MHz)	Reading(dBμV/m)		Factor Corr. (dB)	Result(dBμV/m)		Limit(dBμV/m)		Margin(dBμV/m)		Polarization
	AV	PEAK		AV	PEAK	AV	PEAK	AV	PEAK	
-	-	-	-	-	-	-	-	-	-	Vertical
-	-	-	-	-	-	-	-	-	-	Horizontal

**Note: 1. Emissions attenuated more than 20 dB below the permissible value are not reported.****2. \*: Denotes restricted band of operation.****3. The fundamental radiated emissions were reduced by Band Reject Filter in the attached plots.**

Date of Test:	<u>July 25, 2013</u>	Temperature:	<u>25°C</u>
EUT:	<u>Wifi Repeater</u>	Humidity:	<u>50%</u>
Model No.:	<u>VRP150</u>	Power Supply:	<u>AC120V/60Hz</u>
	<u>802.11n Channel Low 2412MHz</u>		
Test Mode:	<u>(20MHz)</u>	Test Engineer:	<u>Star</u>

**For 30MHz-1000MHz**

Corrected Factor = Antenna Factor + Cable Loss – Amplifier Gain

Frequency (MHz)	Reading (dBμV/m)	Factor Corr. (dB)	Result (dBμV/m)	Limit (dBμV/m)	Margin (dB)	Polarization
	QP		QP	QP	QP	
601.4265	46.40	-11.65	34.75	46.50	-11.75	Vertical
721.7259	50.47	-9.28	41.19	46.50	-5.31	
842.1295	42.68	-7.10	35.58	46.50	-10.92	
360.4476	56.66	-15.92	40.74	46.50	-5.76	Horizontal
721.7259	54.11	-9.28	44.83	46.50	-1.67	
842.1295	48.48	-7.10	41.38	46.50	-5.12	

**For 1GHz-25GHz**

Corrected Factor = Antenna Factor + Cable Loss – Amplifier Gain

Frequency (MHz)	Reading(dBμV/m)		Factor Corr. (dB)	Result(dBμV/m)		Limit(dBμV/m)		Margin(dBμV/m)		Polarization
	AV	PEAK		AV	PEAK	AV	PEAK	AV	PEAK	
-	-	-	-	-	-	-	-	-	-	Vertical
-	-	-	-	-	-	-	-	-	-	Horizontal

**Note: 1. Emissions attenuated more than 20 dB below the permissible value are not reported.**

**2. \*: Denotes restricted band of operation.**

**3. The fundamental radiated emissions were reduced by Band Reject Filter in the attached plots.**

Date of Test:	<u>July 25, 2013</u>	Temperature:	<u>25°C</u>
EUT:	<u>Wifi Repeater</u>	Humidity:	<u>50%</u>
Model No.:	<u>VRP150</u>	Power Supply:	<u>AC120V/60Hz</u>
	<u>802.11n Channel Middle 2437MHz</u>		
Test Mode:	<u>(20MHz)</u>	Test Engineer:	<u>Star</u>

**For 30MHz-1000MHz**

Corrected Factor = Antenna Factor + Cable Loss – Amplifier Gain

Frequency (MHz)	Reading (dBμV/m)		Factor Corr. (dB)	Result (dBμV/m)		Limit (dBμV/m)	Margin (dB)	Polarization
	QP			QP	QP			
601.4265	47.04		-11.65	35.39		46.50	-11.11	Vertical
721.7259	50.00		-9.28	40.72		46.50	-5.78	
842.1296	42.57		-7.10	35.47		46.50	-11.03	
360.4476	57.20		-15.92	41.28		46.50	-5.22	Horizontal
721.7259	54.30		-9.28	45.02		46.50	-1.48	
842.1296	50.48		-7.10	43.38		46.50	-3.12	

**For 1GHz-25GHz**

Corrected Factor = Antenna Factor + Cable Loss – Amplifier Gain

Frequency (MHz)	Reading(dBμV/m)		Factor Corr. (dB)	Result(dBμV/m)		Limit(dBμV/m)		Margin(dBμV/m)		Polarization
	AV	PEAK		AV	PEAK	AV	PEAK	AV	PEAK	
-	-	-	-	-	-	-	-	-	-	Vertical
-	-	-	-	-	-	-	-	-	-	Horizontal

**Note: 1. Emissions attenuated more than 20 dB below the permissible value are not reported.****2. \*: Denotes restricted band of operation.****3. The fundamental radiated emissions were reduced by Band Reject Filter in the attached plots.**

Date of Test:	<u>July 25, 2013</u>	Temperature:	<u>25°C</u>
EUT:	<u>Wifi Repeater</u>	Humidity:	<u>50%</u>
Model No.:	<u>VRP150</u>	Power Supply:	<u>AC120V/60Hz</u>
	<u>802.11n Channel High 2462MHz</u>		
Test Mode:	<u>(20MHz)</u>	Test Engineer:	<u>Star</u>

**For 30MHz-1000MHz**

Corrected Factor = Antenna Factor + Cable Loss – Amplifier Gain

Frequency (MHz)	Reading (dBμV/m)		Factor Corr. (dB)	Result (dBμV/m)		Limit (dBμV/m)	Margin (dB)	Polarization
	QP			QP	QP			
601.4265	46.74		-11.65	35.09		46.50	-11.41	Vertical
721.7259	50.93		-9.28	41.65		46.50	-4.85	
779.6068	45.20		-8.12	37.08		46.50	-9.42	
360.4476	56.99		-15.92	41.07		46.50	-5.43	Horizontal
721.7259	54.22		-9.28	44.94		46.50	-1.56	
842.1295	49.87		-7.10	42.77		46.50	-3.73	

**For 1GHz-25GHz**

Corrected Factor = Antenna Factor + Cable Loss – Amplifier Gain

Frequency (MHz)	Reading(dBμV/m)		Factor Corr. (dB)	Result(dBμV/m)		Limit(dBμV/m)		Margin(dBμV/m)		Polarization
	AV	PEAK		AV	PEAK	AV	PEAK	AV	PEAK	
-	-	-	-	-	-	-	-	-	-	Vertical
-	-	-	-	-	-	-	-	-	-	Horizontal

**Note: 1. Emissions attenuated more than 20 dB below the permissible value are not reported.**

**2. \*: Denotes restricted band of operation.**

**3. The fundamental radiated emissions were reduced by Band Reject Filter in the attached plots.**

Date of Test:	<u>July 25, 2013</u>	Temperature:	<u>25°C</u>
EUT:	<u>Wifi Repeater</u>	Humidity:	<u>50%</u>
Model No.:	<u>VRP150</u>	Power Supply:	<u>AC120V/60Hz</u>
	<u>802.11n Channel Low 2422MHz</u>		
Test Mode:	<u>(40MHz)</u>	Test Engineer:	<u>Star</u>

**For 30MHz-1000MHz**

Corrected Factor = Antenna Factor + Cable Loss – Amplifier Gain

Frequency (MHz)	Reading (dBμV/m)	Factor Corr. (dB)	Result (dBμV/m)	Limit (dBμV/m)	Margin (dB)	Polarization
	QP		QP	QP	QP	
601.4265	46.48	-11.65	34.83	46.50	-11.67	Vertical
721.7259	50.42	-9.28	41.14	46.50	-5.36	
782.3452	44.73	-8.06	36.67	46.50	-9.83	
360.4476	56.80	-15.92	40.88	46.50	-5.62	Horizontal
721.7259	54.40	-9.28	45.12	46.50	-1.38	
842.1296	50.31	-7.10	43.21	46.50	-3.29	

**For 1GHz-25GHz**

Corrected Factor = Antenna Factor + Cable Loss – Amplifier Gain

Frequency (MHz)	Reading(dBμV/m)		Factor Corr. (dB)	Result(dBμV/m)		Limit(dBμV/m)		Margin(dBμV/m)		Polarization
	AV	PEAK		AV	PEAK	AV	PEAK	AV	PEAK	
-	-	-	-	-	-	-	-	-	-	Vertical
-	-	-	-	-	-	-	-	-	-	Horizontal

**Note: 1. Emissions attenuated more than 20 dB below the permissible value are not reported.**

**2. \*: Denotes restricted band of operation.**

**3. The fundamental radiated emissions were reduced by Band Reject Filter in the attached plots.**

Date of Test:	July 25, 2013	Temperature:	25°C
EUT:	Wifi Repeater	Humidity:	50%
Model No.:	VRP150	Power Supply:	AC120V/60Hz
	802.11n Channel Middle 2437MHz		
Test Mode:	(40MHz)	Test Engineer:	Star

**For 30MHz-1000MHz**

Corrected Factor = Antenna Factor + Cable Loss – Amplifier Gain

Frequency (MHz)	Reading (dBμV/m)		Factor Corr. (dB)	Result (dBμV/m)		Limit (dBμV/m)	Margin (dB)	Polarization
	QP			QP				
601.4265	46.24		-11.65	34.59		46.50	-11.91	Vertical
721.7259	49.63		-9.28	40.35		46.50	-6.15	
842.1295	42.59		-7.10	35.46		46.50	-11.04	
360.4476	57.12		-15.92	41.20		46.50	-5.30	Horizontal
721.7259	54.16		-9.28	44.88		46.50	-1.62	
782.3452	51.65		-8.06	43.59		46.50	-2.91	

**For 1GHz-25GHz**

Corrected Factor = Antenna Factor + Cable Loss – Amplifier Gain

Frequency (MHz)	Reading(dBμV/m)		Factor Corr. (dB)	Result(dBμV/m)		Limit(dBμV/m)		Margin(dBμV/m)		Polarization
	AV	PEAK		AV	PEAK	AV	PEAK	AV	PEAK	
-	-	-	-	-	-	-	-	-	-	Vertical
-	-	-	-	-	-	-	-	-	-	Horizontal

**Note: 1. Emissions attenuated more than 20 dB below the permissible value are not reported.****2. \*: Denotes restricted band of operation.****3. The fundamental radiated emissions were reduced by Band Reject Filter in the attached plots.**



Date of Test:	<u>July 25, 2013</u>	Temperature:	<u>25°C</u>
EUT:	<u>Wifi Repeater</u>	Humidity:	<u>50%</u>
Model No.:	<u>VRP150</u>	Power Supply:	<u>AC120V/60Hz</u>
	<u>802.11n Channel High 2452MHz</u>		
Test Mode:	<u>(40MHz)</u>	Test Engineer:	<u>Star</u>

**For 30MHz-1000MHz**

Corrected Factor = Antenna Factor + Cable Loss – Amplifier Gain

Frequency (MHz)	Reading (dBμV/m)	Factor Corr. (dB)	Result (dBμV/m)	Limit (dBμV/m)	Margin (dB)	Polarization
	QP		QP	QP	QP	
601.4265	46.53	-11.65	34.88	46.50	-11.62	Vertical
721.7259	49.95	-9.28	40.67	46.50	-5.83	
842.1296	42.38	-7.10	35.28	46.50	-11.22	
721.7259	54.41	-9.28	45.13	46.50	-1.37	Horizontal
779.6068	52.26	-8.12	44.14	46.50	-2.36	
842.1296	50.08	-7.10	42.98	46.50	-3.52	

**For 1GHz-25GHz**

Corrected Factor = Antenna Factor + Cable Loss – Amplifier Gain

Frequency (MHz)	Reading(dBμV/m)		Factor Corr. (dB)	Result(dBμV/m)		Limit(dBμV/m)		Margin(dBμV/m)		Polarization
	AV	PEAK		AV	PEAK	AV	PEAK	AV	PEAK	
-	-	-	-	-	-	-	-	-	-	Vertical
-	-	-	-	-	-	-	-	-	-	Horizontal

**Note: 1. Emissions attenuated more than 20 dB below the permissible value are not reported.**

**2. \*: Denotes restricted band of operation.**

**3. The fundamental radiated emissions were reduced by Band Reject Filter in the attached plots.**



**ACCURATE TECHNOLOGY CO., LTD.**

F1,Bldg,A,Changyuan New Material Port Keyuan Rd,  
Science & Industry Park,Nanshan Shenzhen,P.R.China

Site: 1# Chamber  
Tel:+86-0755-26503290  
Fax:+86-0755-26503396

Job No.: star #2335	Polarization: Horizontal
Standard: FCC Class B 3M Radiated	Power Source: DC 5V
Test item: Radiation Test	Date: 13/07/25/
Temp.( C)/Hum.(%) 25 C / 55 %	Time: 9/25/37
EUT: Wifi Repeater	Engineer Signature: STAR
Mode: TX Channel 1(802.11b)	Distance: 3m
Model: VRP150	
Manufacturer: HouTian	

Note: Report No.:ATE20131606

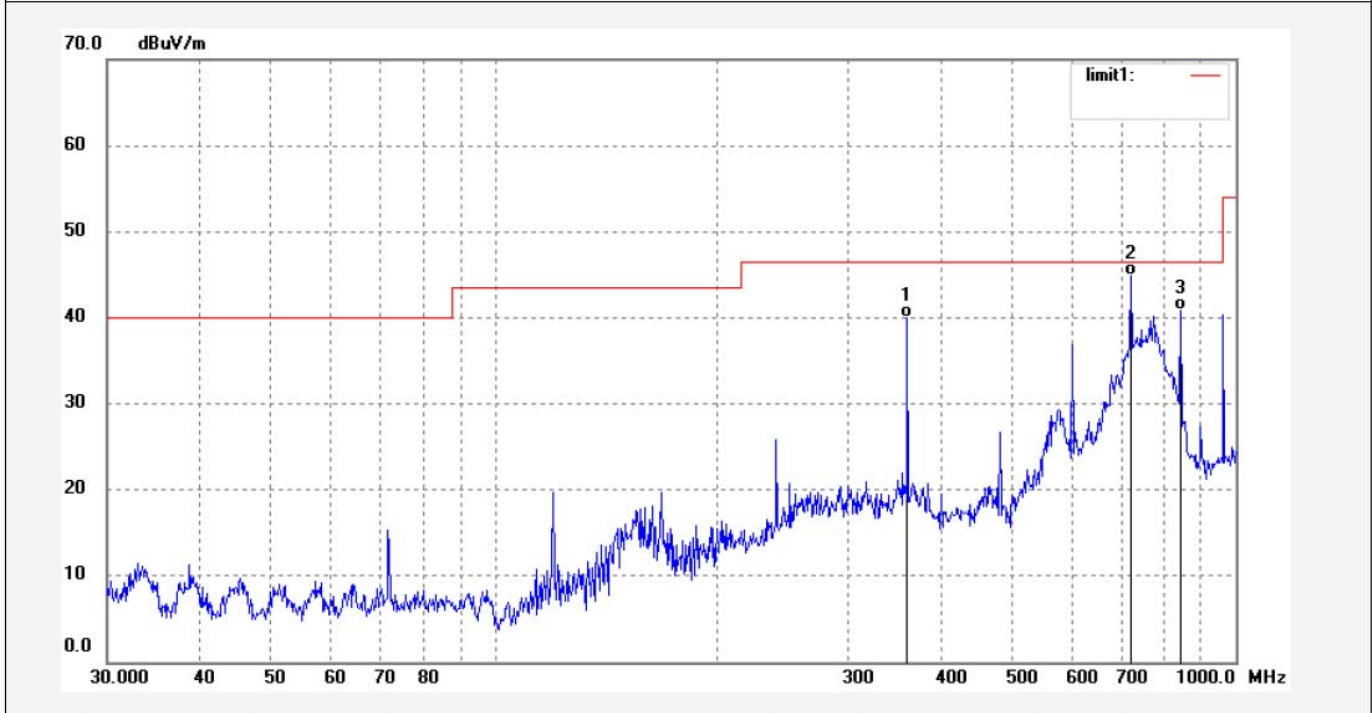

No.	Freq. (MHz)	Reading (dBuV/m)	Factor (dB)	Result (dBuV/m)	Limit (dBuV/m)	Margin (dB)	Detector	Height (cm)	Degree (deg.)	Remark
1	360.4476	55.98	-15.92	40.06	46.50	-6.44	QP			
2	721.7259	54.25	-9.28	44.97	46.50	-1.53	QP			
3	842.1295	47.92	-7.10	40.82	46.50	-5.68	QP			



**ACCURATE TECHNOLOGY CO., LTD.**

F1,Bldg,A,Changyuan New Material Port Keyuan Rd,  
Science & Industry Park,Nanshan Shenzhen,P.R.China

Site: 1# Chamber  
Tel:+86-0755-26503290  
Fax:+86-0755-26503396

Job No.: star #2336  
Standard: FCC Class B 3M Radiated  
Test item: Radiation Test  
Temp.( C)/Hum.(%) 25 C / 55 %  
EUT: Wifi Repeater  
Mode: TX Channel 1(802.11b)  
Model: VRP150  
Manufacturer: HouTian

Polarization: Vertical  
Power Source: DC 5V  
Date: 13/07/25/  
Time: 9/28/17  
Engineer Signature: STAR  
Distance: 3m

Note: Report No.:ATE20131606

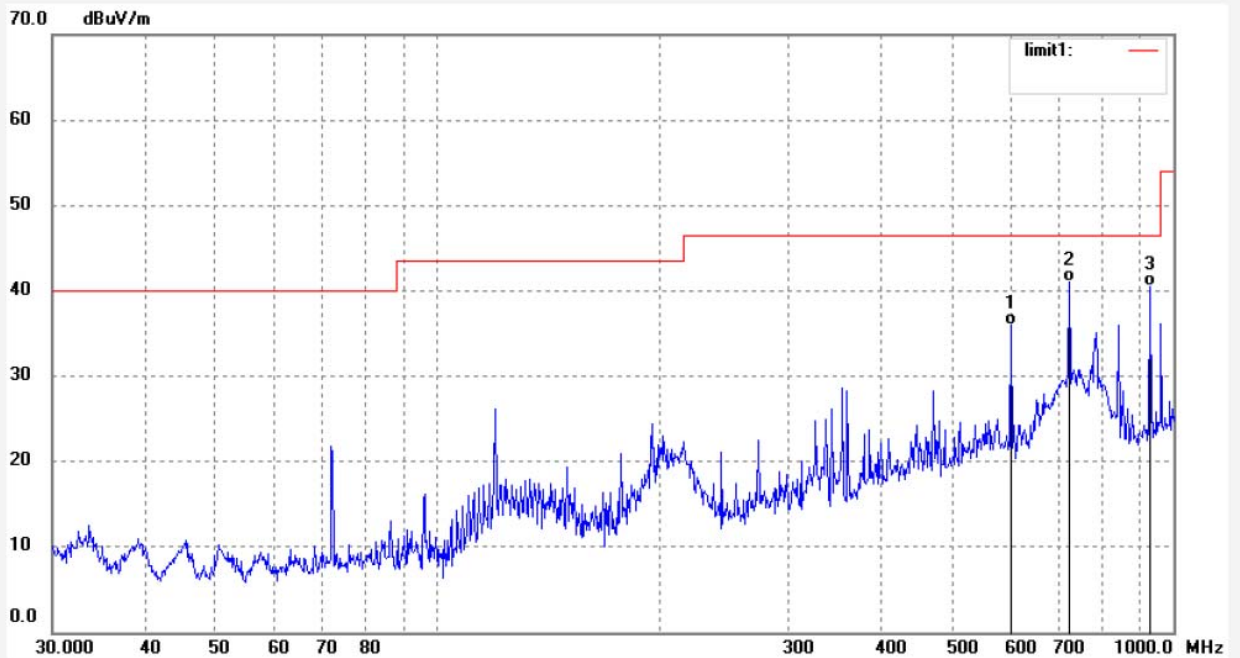

No.	Freq. (MHz)	Reading (dBuV/m)	Factor (dB)	Result (dBuV/m)	Limit (dBuV/m)	Margin (dB)	Detector	Height (cm)	Degree (deg.)	Remark
1	601.4265	47.56	-11.65	35.91	46.50	-10.59	QP			
2	721.7259	50.31	-9.28	41.03	46.50	-5.47	QP			
3	929.0082	46.15	-5.70	40.45	46.50	-6.05	QP			



**ACCURATE TECHNOLOGY CO., LTD.**

F1,Bldg,A,Changyuan New Material Port Keyuan Rd,  
Science & Industry Park,Nanshan Shenzhen,P.R.China

Site: 2# chamber  
Tel:+86-0755-26503290  
Fax:+86-0755-26503396

Job No.: star #2509	Polarization: Horizontal
Standard: FCC Class B 3M Radiated	Power Source: DC 5V
Test item: Radiation Test	Date: 13/07/24/
Temp.( C)/Hum.(%) 23 C / 49 %	Time: 10/02/57
EUT: Wifi Repeater	Engineer Signature:
Mode: TX Channel 1(802.11b)	Distance: 3m
Model: VRP150	
Manufacturer: HouTian	

Note: Report No.:ATE20131606

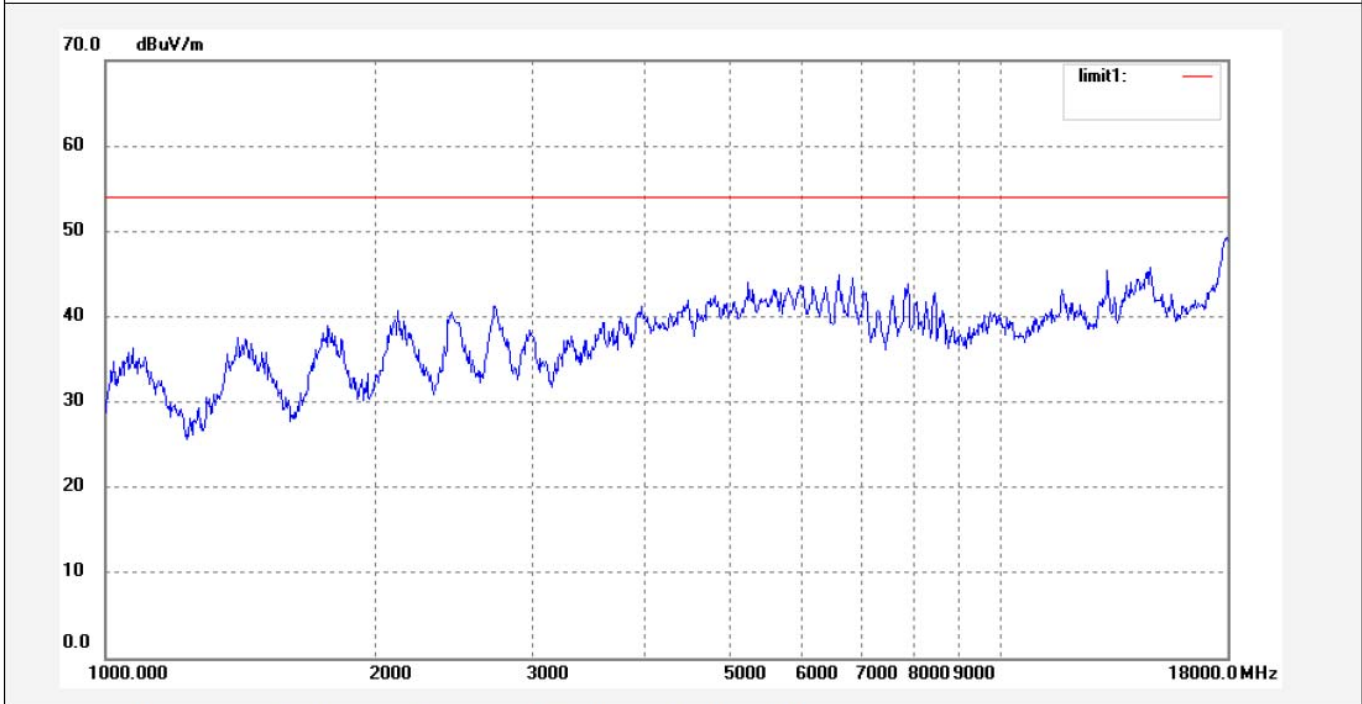

No.	Freq. (MHz)	Reading (dBuV/m)	Factor (dB)	Result (dBuV/m)	Limit (dBuV/m)	Margin (dB)	Detector	Height (cm)	Degree (deg.)	Remark
-----	-------------	------------------	-------------	-----------------	----------------	-------------	----------	-------------	---------------	--------



**ACCURATE TECHNOLOGY CO., LTD.**

F1,Bldg,A,Changyuan New Material Port Keyuan Rd,  
Science & Industry Park,Nanshan Shenzhen,P.R.China

Site: 2# chamber  
Tel:+86-0755-26503290  
Fax:+86-0755-26503396

Job No.: star #2510  
Standard: FCC Class B 3M Radiated  
Test item: Radiation Test  
Temp.( C)/Hum.(%) 23 C / 49 %  
EUT: Wifi Repeater  
Mode: TX Channel 1(802.11b)  
Model: VRP150  
Manufacturer: HouTian

Polarization: Vertical  
Power Source: DC 5V  
Date: 13/07/24/  
Time: 10/06/21  
Engineer Signature:  
Distance: 3m

Note: Report No.:ATE20131606

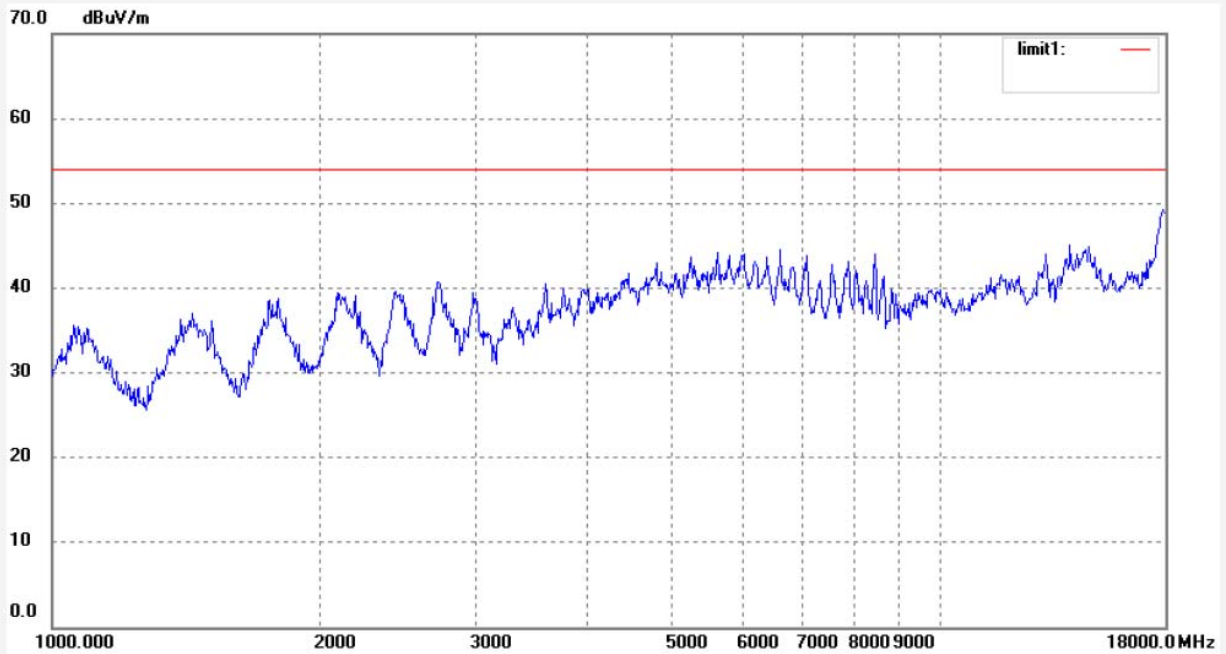

No.	Freq. (MHz)	Reading (dBuV/m)	Factor (dB)	Result (dBuV/m)	Limit (dBuV/m)	Margin (dB)	Detector	Height (cm)	Degree (deg.)	Remark
-----	-------------	------------------	-------------	-----------------	----------------	-------------	----------	-------------	---------------	--------



**ACCURATE TECHNOLOGY CO., LTD.**

F1,Bldg,A,Changyuan New Material Port Keyuan Rd,  
Science & Industry Park,Nanshan Shenzhen,P.R.China

Site: 2# chamber  
Tel:+86-0755-26503290  
Fax:+86-0755-26503396

Job No.: star #2533  
Standard: FCC Class B 3M Radiated  
Test item: Radiation Test  
Temp.( C)/Hum.(%) 23 C / 49 %  
EUT: Wifi Repeater  
Mode: TX Channel 1(802.11b)  
Model: VRP150  
Manufacturer: HouTian

Polarization: Vertical  
Power Source: DC 5V  
Date: 13/07/25/  
Time: 11/35/40  
Engineer Signature:  
Distance: 3m

Note: Report No.:ATE20131606

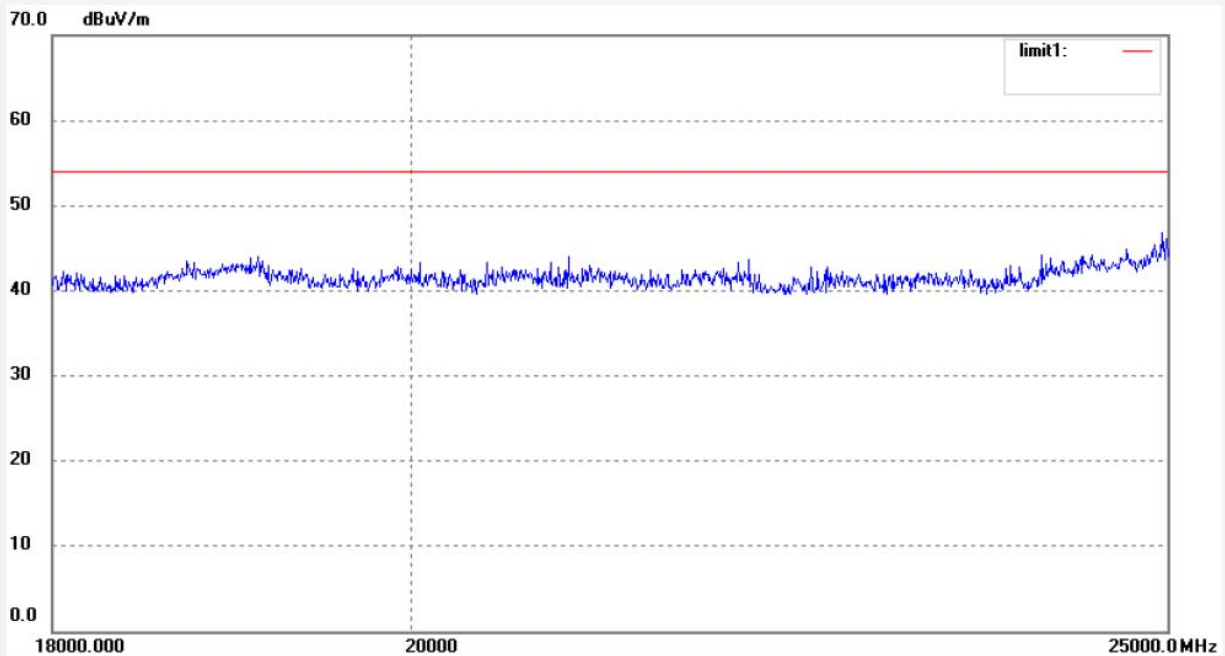

No.	Freq. (MHz)	Reading (dBuV/m)	Factor (dB)	Result (dBuV/m)	Limit (dBuV/m)	Margin (dB)	Detector	Height (cm)	Degree (deg.)	Remark
-----	-------------	------------------	-------------	-----------------	----------------	-------------	----------	-------------	---------------	--------