

SYLVANIA

BLUETOOTH SPORTS HEADPHONES

MA-2430



EN

1. REPLACEMENT PARTS - When replacement parts are required, be sure the service technician has used replacement parts specified by the manufacturer or have the same characteristics as the original part. Unauthorized substitutions may result in fire, electric shock, or other hazards.

2. SAFETY CHECK - Upon completion of any service or repairs to this product, ask the service technician to perform safety checks to determine that the product is in proper operating condition.

3. HEAT - The product should be situated away from heat sources such as radiators, heat registers, stoves, or other products (including amplifiers) that produce heat.

Warning: Changes or modifications to this unit not expressly approved by the party responsible for compliance could void the users' authority to operate the equipment.

FCC Statement

This equipment has been tested and found to comply with the limits for a Class B digital device, pursuant to Part 15 of the FCC Rules. These limits are designed to provide reasonable protection against harmful interference in a residential installation. This equipment generates uses and can radiate radio frequency energy and, if not installed and used in accordance with the instructions, may cause harmful interference to radio communications. However, there is no guarantee that interference will not occur in a particular installation. If this equipment does cause harmful interference to radio or television reception, which can be determined by turning the equipment off and on, the user is encouraged to try to correct the interference by one or more of the following measures:

- Reorient or relocate the receiving antenna.
- Increase the separation between the equipment and receiver.
- Connect the equipment into an outlet on a circuit different from that to which the receiver is connected. -- Consult the dealer or an experienced radio/TV technician for help.

This device complies with part 15 of the FCC Rules. Operation is subject to the following two conditions: (1) This device may not cause harmful interference, and (2) this device must accept any interference received, including interference that may cause undesired operation.

Changes or modifications not expressly approved by the party responsible for compliance could void the user's authority to operate the equipment.

Location of Controls:

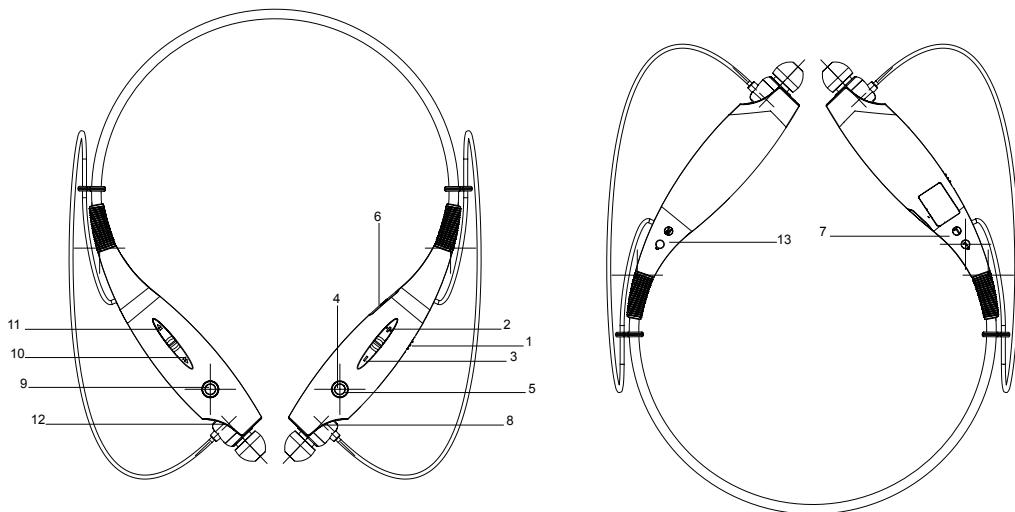

1. Power ON/OFF Switch
2. Volume Up
3. Volume Down
4. Answer Call / End Call
5. LED Indicator Light
6. Micro USB DC 5V Charging Port
7. Left Channel
8. Magnetic Holder for Left Earbuds
9. Pause
10. Previous Track
11. Next Track
12. Magnetic Holder for Right Earbuds
13. Right Channel



Specifications

Bluetooth 2.1 (Headset/Hands-Free/A2DP Profiles)

Battery: Built-in rechargeable 3.7V / 170mAh lithium battery

Standby time: Up to 200hrs

Talk time: Up to 3hrs

Music play time: Up to 3hrs

Charging time: < 2.5hrs

Operating range: Up to 10 meters

Operation temperature: -10 °C ~60 °C

Dimension: 135.6mm(W)x167.3mm(L)x16.9mm(T)

Weight: 32g

How to Use

To turn it on:

Move the power switch to the 'ON' side to turn on the headphone while it vibrates one second and the blue light flash.

To turn it off:

Move the power switch to the 'OFF' side to turn off the headphone.

To pair it:

Move the power switch to the 'ON' side, then it will vibrate and flash blue light then you will hear "Power supply has been on".

When the Bluetooth enabled device finds it, select **Sylvania MA-2430** from the list of found devices. Once the headset enters Pairing Mode, the LED indicator will show a blinking blue light.

If asked for the PASS/PIN code please enter "0000"(4 zeros).

Note: If your handset supports Secure Simple Pairing (SSP), you will not need to enter PASS/PIN code.

-Once pairing has completed successfully, you will hear "Already connected".

Some handsets might ask for permission to access the phone's contact list. If you receive a message from your handset, please select "OK" or "Allow access"

To answer a phone call:

Press Answer Call / End Call button to answer a phone call.

To reject a phone call:

Long press Answer Call / End Call button to reject the call.

To play the music:

Press Play/Pause button to play or pause music.

Charge the battery:

1. Plug the Micro-USB charging cable into the headset.
2. Plug the USB port on a computer or power adapter.
3. Charge for 2.5 hours or until the Battery status red light turns off.

Caution:

1. When not in use for a prolonged period, it is recommended that you turn off the headset to lengthen the battery life.
2. When the power blue light flashing, it is recommended that charging the headset not less than 3 hours.

Safety Caution

1. Keep the item away from sharp objects.
2. Do not place heavy object on the headset.
3. Away from microwave items.
4. Do not force or distorted the headset.
5. Keep away from oil, chemical or other organic liquid items.