

承 認 書

SPECIFICATION FOR APPROVAL

客 戶: CUSTOMER:	DONG GUAN KAFULLE ELECTRONICS CO.LTD
客 戶 料 號: CUST P/N:	
松 島 料 號: FINE P/N:	G43-6.3uH Single coil0.15*15P*10TS
產 品 型 號: DESC:	Φ43MMX5.3MMX0.65MM Double-slot magnetic sheet
日 期: DATE:	2023/11/07
版 本: Version:	A.0

擬 制 PREPARED BY	審 核 CHECKED BY	批 准 APPROVED BY	客 戶 承 認 CUSTOMER APPROVE

Manufacturer:Shenzhensongdaotechnologyco.,ltd

Factory Address: 8th Floor, Building 2, Sanjia High-tech Industrial Park, No.123

Junfa Third Road, Dongkeng Town, Dongguan City

TEL: 13728755750

FAX: 0755-84526500

E-mail: 506388681@qq.com

SPECIFICATION

產品型號: DESC	Φ 20.5x37-6.3uH-0.15x15-30mm	版本 Rev: A.0	客戶 CUST: 客戶料号 CUST P/N:	XXX
---------------	------------------------------	----------------	----------------------------	------------

一、尺寸 DIMENSION:(mm)

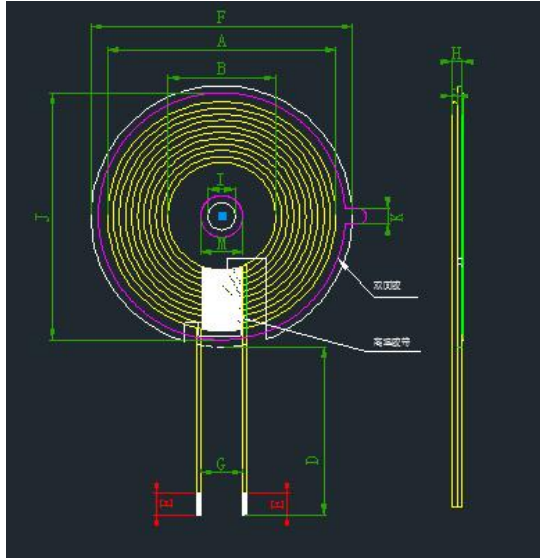

A	37±0.5
B	20.5±0.5
C	1.25 Max
D	30±2
E	4±2
F	43±0.5
G	10.0 ref
H	1.7±0.1
I	5.3 ref
M	8.0 ref
J	42±1
K	3.0±1

二、原理图 SCHEMATIC DIAGRAM:

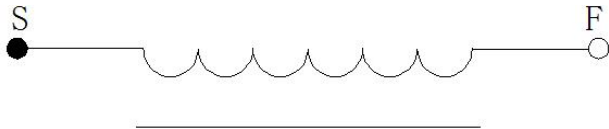

Note:

1. Cross outgoing line;
2. Wrap 9mm(ref) width high-temperature adhesive tape for 1-2Ts at the outlet position;
3. The coil is attached with a circular hard magnetic sheet with a groove, the size of the magnetic sheet is 43.5 ±0.5mm, the inner hole is 5.3mm, and the thickness is 0.65 0.2 mm. .

三、绕线参数 Winding Specification:

序号 NO.	端子 TERMINAL		线径 WIRE	圈数 Turns	绕线方向 Winding Direction
1	S	F	丝包线 0.15*15P	10Ts	CCW

四、电气特性 ELECTRICAL CHARACTERISTICS:

温度 TEMPERATURE:25±10°C, 湿度 RELATIVE HUMIDITY:65±20%

序号 NO.	项目 ITEM	端子 TERMINAL	标准 SPECIFICATION	测试条件 TEST FREQUENCY	测试仪器 TEST EQUIPMENTS
1	IND.	S-F	3.8uH ±20%Separate coil	100KHz/1.0V	LCZ METER 1062B
2	IND.	S-F	6.5uH ±10%Add magnetic disk	100KHz/1.0V	LCZ METER 1062B
3	DCR	S-F	≤75m Ω	100KHz/1.0V	LCZ METER 502B
4	Q	S-F	≥40	100KHz/1.0V	LCZ METER 502B

拟制/日期 PREPARED BY/DATE	审核/日期 CHECKED BY/DATE
2023/11/07	2023/11/07