



深圳市深广电子科技有限公司

Shenzhen Shenguang Electronic Technology Co.,LTD

客户/Client **DONG GUAN KAFULLE ELECTRONICS CO.LTD**

名称/TYPE Magnetic disk 43.5 * 5.3 * 0.8; Adhesive tape, high temperature adhesive tape, l = 200mm6.5uh.

产品型号

Model NO **SG-A1143.5-6.5UH**

产品编号 **SG-A1143.5-200-002**

Part numbering systey

客户料号

Client p/NO

工程编号

Enginrer NO **TQE 1800510003**

日期/Date **2023-11-7**

本公司工程部/For Enginer Departner Only	
修改内容/Rvised Content	认可日期/APProved Date

编制/Prepared

XieYanQi

审核/Checked

DuanJiaWang

认可/Approved

XieXiaoZai

客户认可回签/Authorixed Signaturure Company Chop		
工程/ Enginrer	认可/QC APProved	认可日期/APProved



深圳市深广电子科技有限公司

Shenzhen Shenguang Electronic Technology Co.,LTD

一、线圈工艺/Winding Procese:

NO	winding	wire gauge	number of windings	direction of winding	remarks
1	N1	2UEW-B-0.08*24P*2	10TS	CCW	
2					

二. 电气性能/FEATURES:

1. (Test conditions) : 25°C,65%RH@100KHz/1V

1.1 (Inductance)

1.11 L0A (single coil)=3.8uH±20%

1.12 L0A(Coil+magnetic sheet)=6.5uH±10%

1.2 Q value=35MIN

1.3 Dc resistance (DCR) : 85mΩ MAX

1.4 (Operating Temperature): -25°C~85°C

2.(Test instrument): L:1068+1310;DCR:502BC;SIZE:Callipers

3.bill of materials

NO	project	material
1	WIRE	φ 0.08-24-2P 2UEW
2	FERRITE	43.5*5.3*0.8 LDouble-slot ferrite hard magnetism
3	GLUE	white bonding adhesive
4	SOLDER	XCD-907B
5	Adhesive	Double-sided adhesive
6	High temperature adhesive	6MM(ref)High temperature adhesive tape
7		

三. 电路图/CIRCUIT DIAGRAM



单位: MM

四. 外形图/OUTSIDE DIAGRA

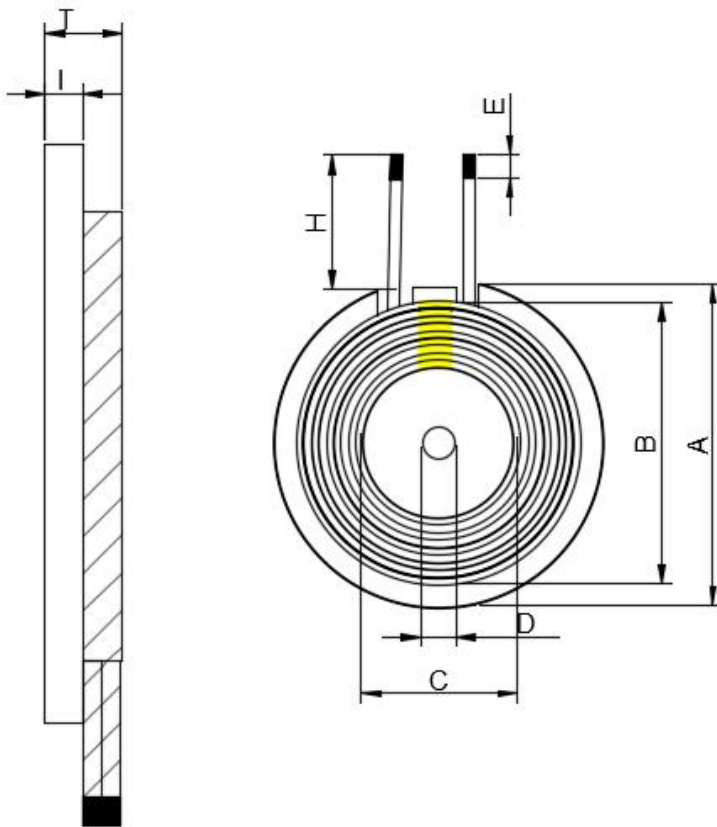

Note: 6MM(ref) high-temperature adhesive tape is wound at the outlet position of the coil.

stan dard	A	B	C	D	E	I	T	H
STD	43.5±0.5	39.0±1.5	5.3±0.5	20.5±0.5	2-5	0.8±0.15	2.6Max	200±5

unit of length: MM

五. 包装/PACKAGE

5.1 包装图片 Packing pictures:

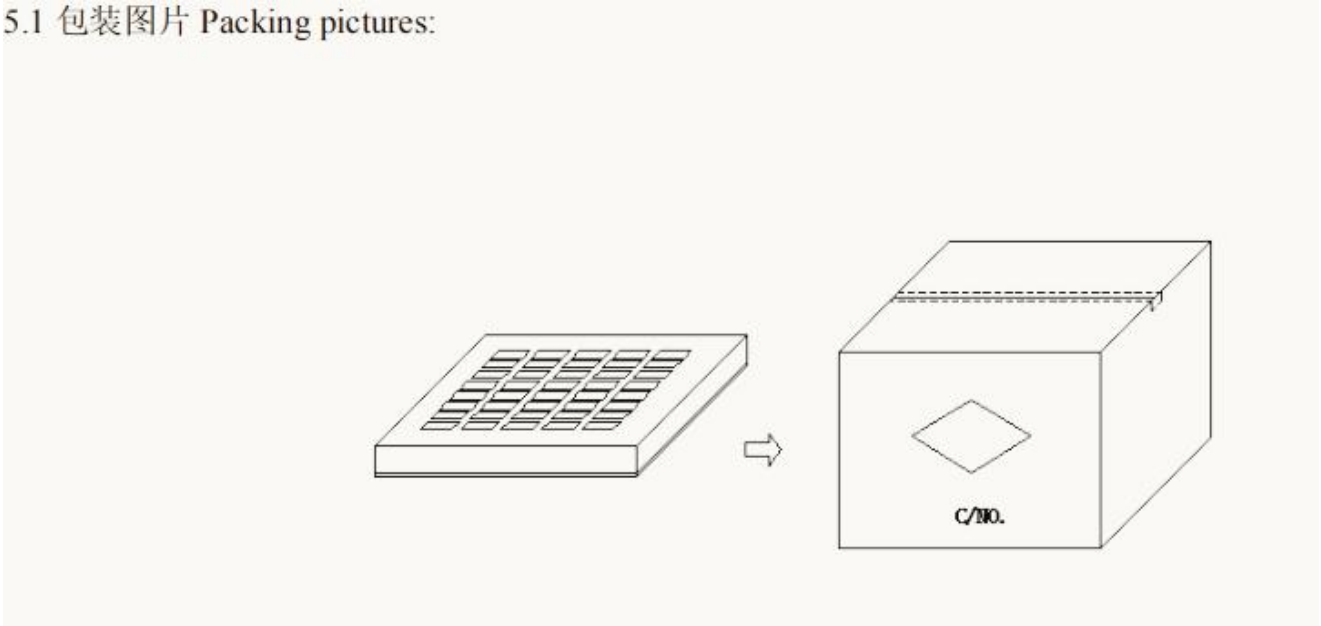

5.2 包装数量及规格 Packing Quantity:

项目 Item	数量 Quantity	材料规格 Material
盒 Box	350 Pcs	345*330*50 mm
箱 Big Carton	1400 Pcs	360*340*280 mm

5.3 包装以现有包装盘为参照标准，以实际出货包装为准，如有特要求可以定制。

The packaging shall be based on the existing packing plate and the actual delivery package shall prevail .If there is any requirement,we can customize it.



深圳市深广电子科技有限公司

Shenzhen Shenguang Electronic Technology Co.,LTD

六、贮存和使用条件 Storage and Use condition

6.1 贮存条件 Storage condition

6.1.1 建议贮存条件：温度 $-25^{\circ}\text{C} \sim 85^{\circ}\text{C}$ ，湿度 70% (Max.)

Recommended keeping conditions: $-25^{\circ}\text{C} \sim 85^{\circ}\text{C}$, 70%RH (Max.)

6.1.2 贮存期限：自生产之日起六个月内

Storage life : Within the limits of six months from being produced.

6.2 使用条件 Use condition

使用条件限制：温度 $-25^{\circ}\text{C} \sim 85^{\circ}\text{C}$ ，湿度 $\leq 90\%$

Use condition limit: $T=-25^{\circ}\text{C} \sim 85^{\circ}\text{C}$, $\text{RH} \leq 90\%$.

Manufacturer: Shenzhen Shenguang Electronic Technology Co.,LTD

Address: No.1165 Guangguan Road, Guihua Community, guanlan street, Longhua District, Shenzhen, China.