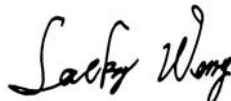

FCC Radio Test Report

FCC ID: 2AAPFMKWFT-T

Report No. : TB-FCC137776
Applicant : Hongkong Meike Digital Technology Co., LTD.
Equipment Under Test (EUT)
EUT Name : Wireless Flash Trigger
Model No. : MK-RC8
Serial No. : MK-RC7, MK-RC9, MK-RC10, MK-RC11, MK-RC12, MKRC13,
MK-RC14, MK-RC15, MK-RC16, MK-RC17, MK- RC18, MK-RC19,
MK-RC20
Brand Name : Meike
Receipt Date : 2013-07-08
Test Date : 2013-07-30 to 2013-08-05
Issue Date : 2013-08-07
Standards : FCC Part 15, Subpart C(15.249)
Test Method : ANSI C63.4:2003
Conclusions : **PASS**

In the configuration tested, the EUT complied with the standards specified above,
The EUT technically complies with the FCC requirements

Test/Witness Engineer : 
Approved & Authorized : 

This report details the results of the testing carried out on one sample. The results contained in this test report do not relate to other samples of the same product. The manufacturer should ensure that all products in series production are in conformity with the product sample detailed in the report.

Contents

CONTENTS	2
1. GENERAL INFORMATION ABOUT EUT	4
1.1 Client Information.....	4
1.2 General Description of EUT (Equipment Under Test)	4
1.3 Block Diagram Showing the Configuration of System Tested.....	5
1.4 Description of Support Units	5
1.5 Description of Test Mode.....	5
1.6 Description of Test Software Setting	6
1.7 Test Facility.....	7
2. TEST SUMMARY	7
3. CONDUCTED EMISSION TEST	9
3.1 Test Standard and Limit.....	9
3.2 Test Setup.....	9
3.3 Test Procedure.....	9
3.4 Test Equipment Used.....	10
3.5 EUT Operating Mode	10
3.6 Test Data.....	10
4. RADIATED EMISSION TEST	11
4.1 Test Standard and Limit.....	11
4.2 Test Setup.....	12
4.3 Test Procedure.....	13
4.4 EUT Operating Condition	13
4.5 Test Equipment	14
4.6 Test Data.....	14
5. RESTRICTED BANDS REQUIREMENT	20
5.1 Test Standard and Limit.....	20
5.2 Test Setup.....	20
5.3 Test Procedure.....	20
5.4 EUT Operating Condition	21
5.5 Test Equipment	21
5.6 Test Data.....	22
6. BANDWIDTH TEST	23
6.1 Test Setup.....	23
6.2 Test Procedure.....	23
6.3 EUT Operating Condition	23
6.4 Test Equipment	23
6.5 Test Data.....	23

7.	ANTENNA REQUIREMENT.....	25
	7.1 Standard Requirement.....	25
	7.2 Antenna Connected Construction	25
	7.3 Result.....	25

1. General Information About EUT

1.1 Client Information

Applicant : Hongkong Meike Digital Technology Co., LTD.
Address : Room 902.9/F., Fu Fai Commercial Centre, 27 Hillier Street , Sheung Wan, Hongkong
Manufacturer : Sky wise Medical Instrument(Shenzhen) CO., LTD.
Address : No.12, Pingxi South Road, Pingdi Town, Longgang District, Shenzhen 518117, China

1.2 General Description of EUT (Equipment Under Test)

EUT Name	:	Wireless Flash Trigger	
Models No.	:	MK-RC8, MK-RC7, MK-RC9, MK-RC10, MK-RC11, MK-RC12, MKRC13, MK-RC14, MK-RC15, MK-RC16, MK-RC17, MK- RC18, MK-RC19, MK-RC20	
Model Difference	:	The different models are identical in schematic, structure and critical component, the only different is the appearance.	
Product Description	:	Operating Frequency:	
		Number of Channels:	1 Channel
		Out Power	RF(2450):98.25 dBuV/m@3m (Peak) 85.49 dBuV/m@3m (Avg)
		Antenna Gain:	2 dBi
		Modulation Type:	FSK
Power Supply	:	DC Voltage supplied by AAA battery.	
Power Rating	:	DC 6.0V by 2*AAA Lithium batteries	
Connecting I/O Port(S)	:	Please refer to the User's Manual	

Note:

- (1) For a more detailed features description, please refer to the manufacturer's specifications or the User's Manual.
- (2) Channel List:

Channel	Frequency (MHz)
CH 1	2450

1.3 Block Diagram Showing the Configuration of System Tested

Mode 1: RF Link Mode

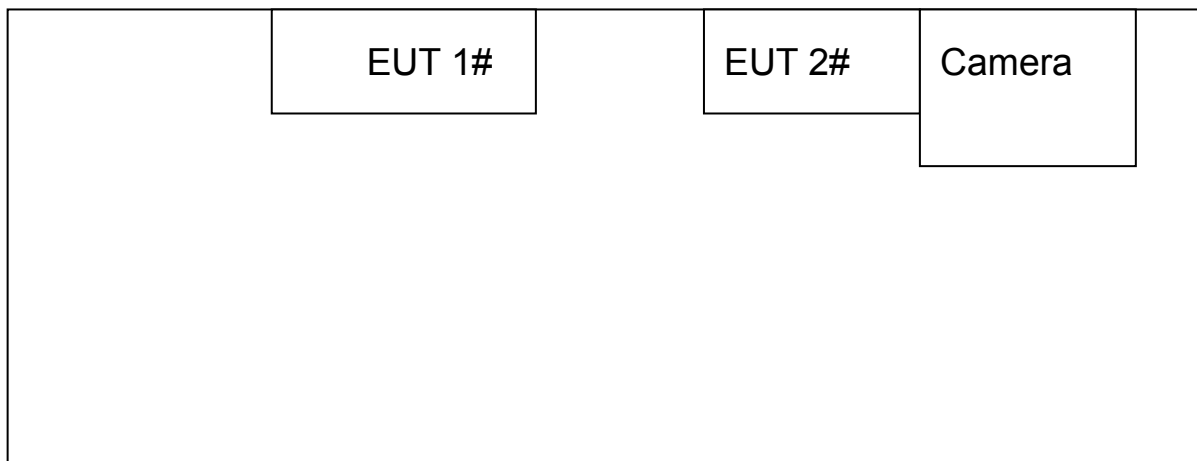

Mode 2: TX Mode

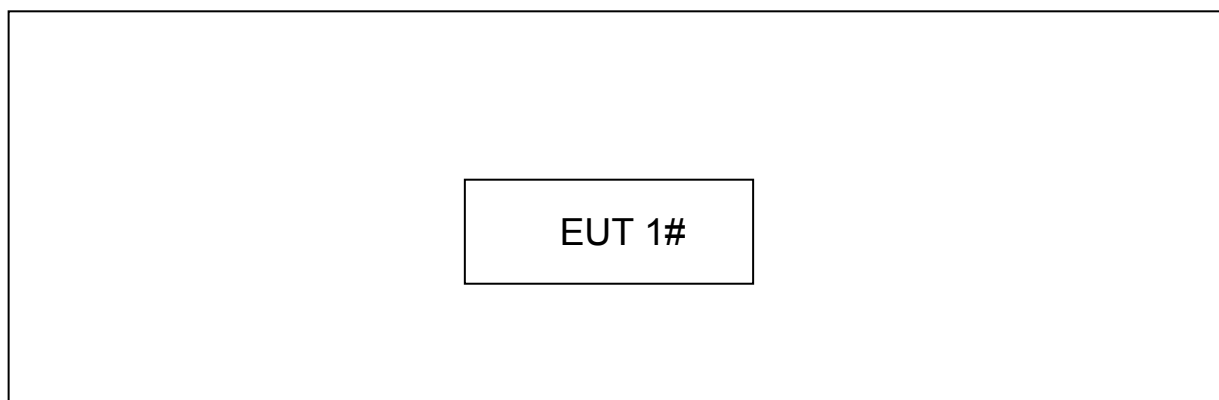

EUT 1#: Wireless Flash Trigger (TX) FCC ID: 2AAPFMKWFT-T

EUT 2#: Wireless Flash Trigger (RX) FCC ID: 2AAPFMKWFT-R

1.4 Description of Support Units

No support units used during testing.

Name	Model	S/N	Manufacturer	Used “√”
---	---	---	---	---

1.5 Description of Test Mode

To investigate the maximum EMI emission characteristics generates from EUT, the test system was pre-scanning tested base on the consideration of following EUT operation mode or test configuration mode which possible have effect on EMI emission level. Each of these

EUT operation mode(s) or test configuration mode(s) mentioned follow was evaluated respectively.

For Conducted Test	
Final Test Mode	Description
N/A	
Note: The equipment is powered by DC battery, and so no requirement for this test.	

For Radiated Test	
Final Test Mode	Description
Mode 1	RF Link Mode
Mode 2	TX Mode

Note:

For all test, we have verified the construction and function in typical operation. And all the test modes were carried out with the EUT in transmitting operation in maximum power with all kinds of data rate.

- (1) According to ANSI C63.4 standards, the measurements are performed at the highest, middle, lowest available channels.
- (2) During the testing procedure, the continuously transmitting with the maximum power mode was programmed by the customer.
- (3) The EUT is considered a portable unit; it was pre-tested on the positioned of each 3 axis, X-plane, Y-plane and Z-plane. The worst case was found positioned on Z-plane. Therefore only the test data of this Z-plane was used for radiated emission measurement test.

1.6 Description of Test Software Setting

During testing channel & Power controlling software provided by the customer was used to control the operating channel as well as the output power level. The RF output power selection is for the setting of RF output power expected by the customer and is going to be fixed on the firmware of the final end product power parameters of RF mode.

Test Software Version	EUT was Programed by the applicant
Frequency	2450 MHz

1.7 Test Facility

The tests were performed at:

Shenzhen Certification Technology Service Co., Ltd

2F, Building B, East Area of Nanchang Second Industrial Zone, Gushu 2nd Road, Bao'an District, Shenzhen, 518126, China

Tel: 86-755-86375552

Fax: 86-755-26736857

At the time of testing, the Laboratory is accredited. It is listed in the United States of American Federal Communications Commission (FCC), and the registration number is 197647.

The test report was fulfilled by Shenzhen Toby Technology Co., Ltd. Shenzhen Toby Technology Co., Ltd. is assumed full responsibility for the accuracy and completeness of these measurements results.

2. Test Summary

FCC Part 15 Subpart C(15.249)			
Standard Section	Test Item	Judgment	Remark
15.203	Antenna Requirement	PASS	N/A
15.205	Restricted Bands	PASS	N/A
15.207	Conducted Emission	PASS	N/A
15.249 &15.209	Radiated Spurious Emission	PASS	N/A
15.215(C)	20dB Bandwidth	PASS	N/A

Note: N/A is an abbreviation for Not Applicable.

3. Conducted Emission Test

3.1 Test Standard and Limit

3.1.1 Test Standard

FCC Part 15.207

3.1.2 Test Limit

Conducted Emission Test Limit

Frequency	Maximum RF Line Voltage (dB μ V)	
	Quasi-peak Level	Average Level
150kHz~500kHz	66 ~ 56 *	56 ~ 46 *
500kHz~5MHz	56	46
5MHz~30MHz	60	50

Notes:

- (1) *Decreasing linearly with logarithm of the frequency.
- (2) The lower limit shall apply at the transition frequencies.
- (3) The limit decrease in line with the logarithm of the frequency in the range of 0.15 to 0.50MHz.

3.2 Test Setup

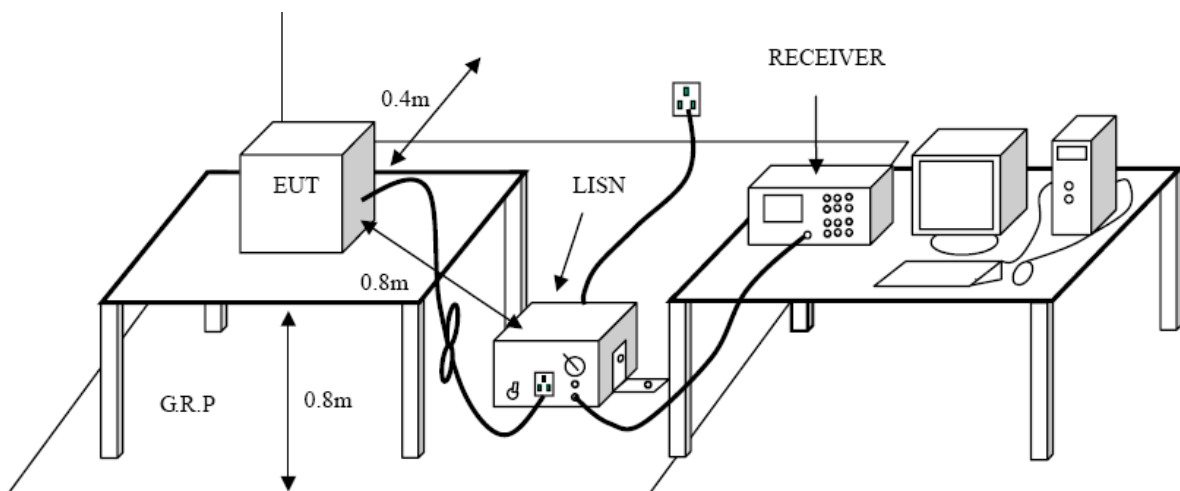

3.3 Test Procedure

The EUT was placed 0.8 meters from the horizontal ground plane with EUT being connected to the power mains through a line impedance stabilization network (LISN). All other support equipments powered from additional LISN(s). The LISN provide 50 Ohm/ 50uH of coupling impedance for the measuring instrument.

Interconnecting cables that hang closer than 40 cm to the ground plane shall be folded back and forth in the center forming a bundle 30 to 40 cm long.

I/O cables that are not connected to a peripheral shall be bundled in the center. The end of the cable may be terminated, if required, using the correct terminating impedance. The overall length shall not exceed 1 m.

LISN at least 80 cm from nearest part of EUT chassis.

The bandwidth of EMI test receiver is set at 9kHz, and the test frequency band is from 0.15MHz to 30MHz.

3.4 Test Equipment Used

Description	Manufacturer	Model No.	Serial No.	Cal. Date	Cal. Due Date
EMI Test Receiver	ROHDE& SCHWARZ	ESCI	100321	2012-08-07	2013-08-06
50Ω Coaxial Switch	Anritsu	MP59B	X10321	2012-08-07	2013-08-06
L.I.S.N	Rohde & Schwarz	ENV216	101131	2012-08-07	2013-08-06
L.I.S.N	SCHWARZBECK	NNBL 8226-2	8226-2/164	2012-08-07	2013-08-06

3.5 EUT Operating Mode

Please refer to the description of test mode.

3.6 Test Data

Please see the next page.

4. Radiated Emission Test

4.1 Test Standard and Limit

4.1.1 Test Standard

FCC Part 15.209

4.1.2 Test Limit

Radiated Emission Limit (9kHz~1000MHz)

Frequency (MHz)	Field Strength (microvolt/meter)	Measurement Distance (meters)
0.009~0.490	2400/F(KHz)	300
0.490~1.705	24000/F(KHz)	30
1.705~30.0	30	30
30~88	100	3
88~216	150	3
216~960	200	3
Above 960	500	3

Radiated Emission Limit (Above 1000MHz)

Frequency (MHz)	Class A (dBuV/m)(at 3 M)		Class B (dBuV/m)(at 3 M)	
	Peak	Average	Peak	Average
Above 1000	80	60	74	54

Note:

- (1) The tighter limit applies at the band edges.
- (2) Emission Level(dBuV/m)=20log Emission Level(Uv/m)

Limits of radiated emission measurement (15.249)

FCC Part 15 (15.249), Subpart C	
Limit	Frequency Range (MHz)
Field strength of fundamental 50000 μ V/m (94 dB μ V/m) @ 3 m	902~928
Field strength of fundamental 50000 μ V/m (94 dB μ V/m) @ 3 m	2400~2483.5
Field strength of fundamental 50000 μ V/m (94 dB μ V/m) @ 3 m	5725~5875
Field strength of fundamental 250000 μ V/m (107.9 dB μ V/m) @ 3 m	24000~24250

4.2 Test Setup

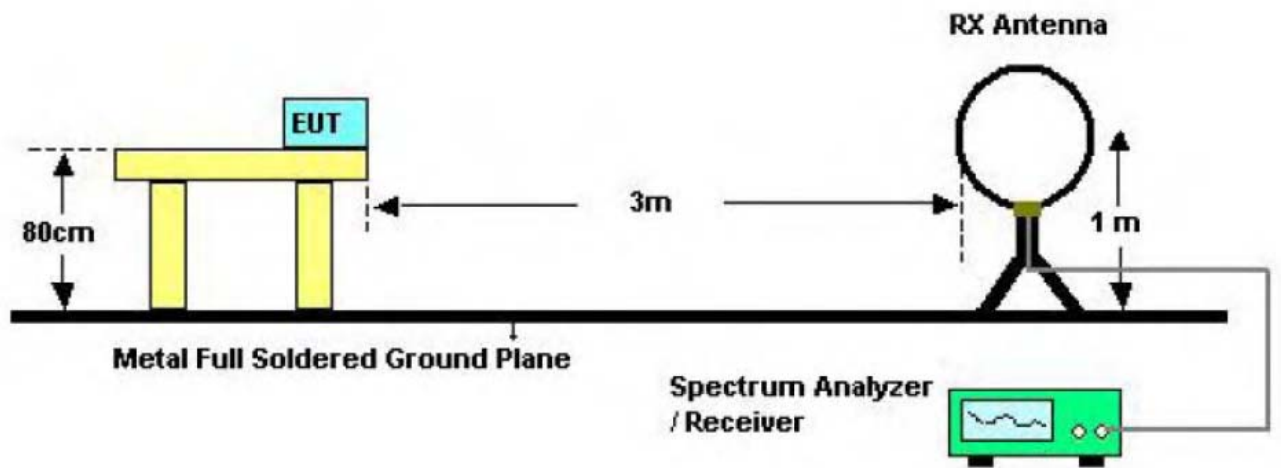

Bellow 30MHz Test Setup

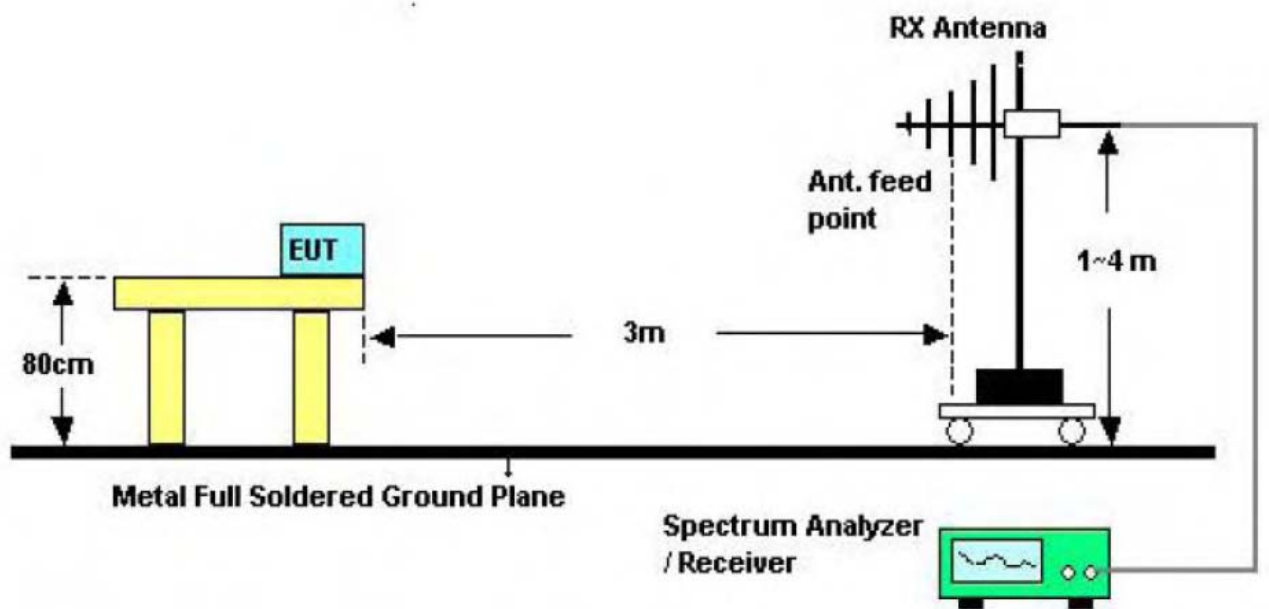

Bellow 1000MHz Test Setup

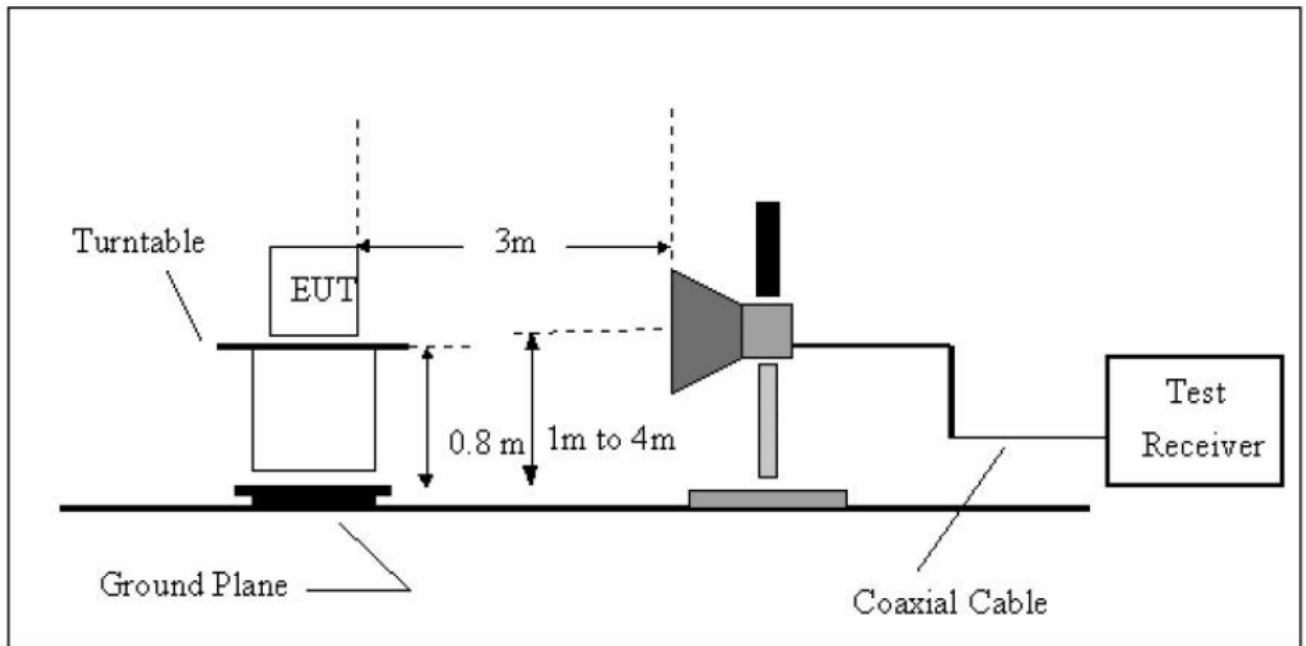

Above 1GHz Test Setup

4.3 Test Procedure

- (1) The measuring distance of 3m shall be used for measurements at frequency up to 1GHz and above 1 GHz. The EUT was placed on a rotating 0.8m high above ground, the table was rotated 360 degrees to determine the position of the highest radiation.
- (2) The Test antenna shall vary between 1m and 4m, Both Horizontal and Vertical antenna are set to make measurement.
- (3) The initial step in collecting conducted emission data is a spectrum analyzer peak detector mode pre-scanning the measurement frequency range. Significant peaks are then marked and then Quasi Peak detector mode re-measured.
- (4) If the Peak Mode measured value compliance with and lower than Quasi Peak Mode Limit Bellow 1 GHz, the EUT shall be deemed to meet QP Limits and then no additional QP Mode measurement performed. But the Peak Value and average value both need to comply with applicable limit above 1 GHz.
- (5) For the actual test configuration, please see the test setup photo.

4.4 EUT Operating Condition

The Equipment Under Test was set to Continual Transmitting in maximum power.

4.5 Test Equipment

Description	Manufacturer	Model No.	Serial No.	Cal. Date	Cal. Due Date
Spectrum Analyzer	ROHDE& SCHWARZ	FSP30	DE25181	2012-12-31	2013-12-30
Spectrum Analyzer	Agilent	E4407B	MY49510055	2012-12-31	2013-12-30
EMI Test Receiver	ROHDE& SCHWARZ	ESCI	101165	2012-12-31	2013-12-30
Bilog Antenna	SCHWARZBECK	VULB9168	9168-438	2013-02-12	2014-02-11
Horn Antenna	SCHWARZBECK	BBHA 9120D	BBHA9120D	2013-02-12	2014-02-11
Horn Antenna	SCHWARZBECK	BBHA 9170	BBHA9170D	2013-02-12	2014-02-11
Active Loop Antenna	Beijing Daze	ZN30900A	SEL0097	2013-02-12	2014-02-11
Pre-amplifier	SCHWARZBECK	BBV9743	9743-019	2012-10-31	2013-10-30
Pre-amplifier	Quietek	AP-180C	CHM-0602012	2012-10-31	2013-10-30

4.6 Test Data

Please see the next page.

Fundamental Power

Freq. (MHz)	Ant. Pol. (H/V)	Emission Level (dBuv/m)	Limit (@3m) (dBuv/m)	Detector	Margin (dB)
2450	V	98.25	114.00	Peak	15.75
2450		85.49	94.00	Average	8.51
2450	H	92.84	114.00	Peak	21.16
2450		80.08	94.00	Average	13.92

Note: During testing the device was set to continual transmitting to demonstrate comply with the FCC standards.

Average=Peak-12.76

Duty Cycle

(1) Continual transmitting mode, 100ms transmitting.

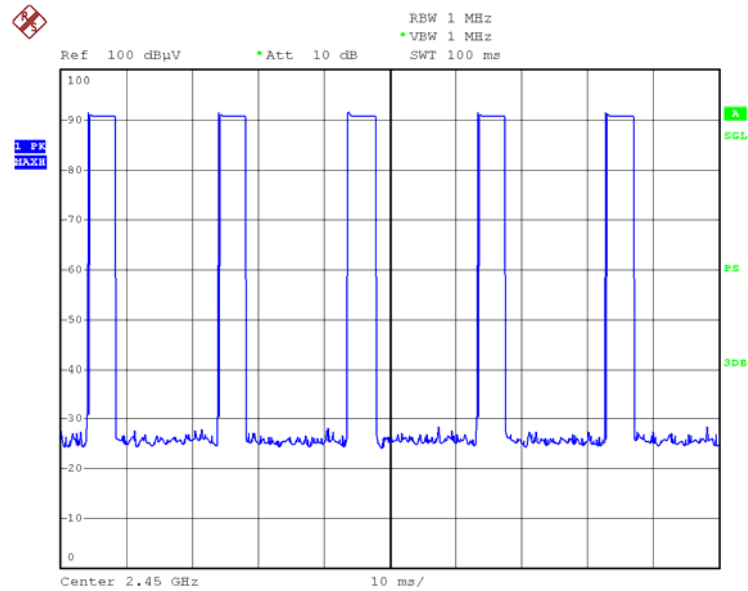

Date: 3.AUG.2013 11:41:06

(2) For each cycle the transmitting time.

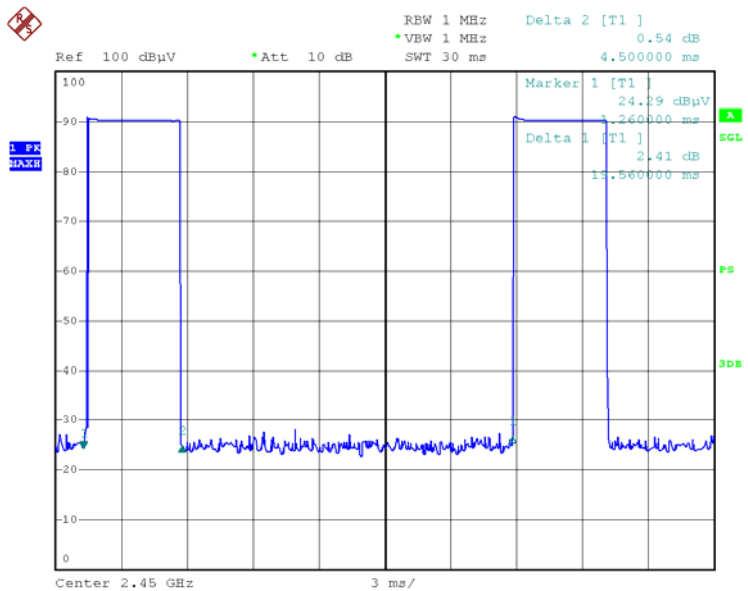

Date: 3.AUG.2013 11:21:57

(3) Duty Cycle=4.5ms/19.56ms=0.23

Avg=Peak+20log(Duty Cycle)=Peak+20*log(0.2)=Peak-12.76

Spurious Emission Bellow 1GHz

Operation Mode:	TX 2450 MHz	Test Date :	August 02, 2013
Frequency Range:	30~1000MHz	Temperature :	28 °C
Measured Distance:	3m	Humidity :	65 %
Test Voltage:	DC 3.0V		
Ant. Pol.	Horizontal		

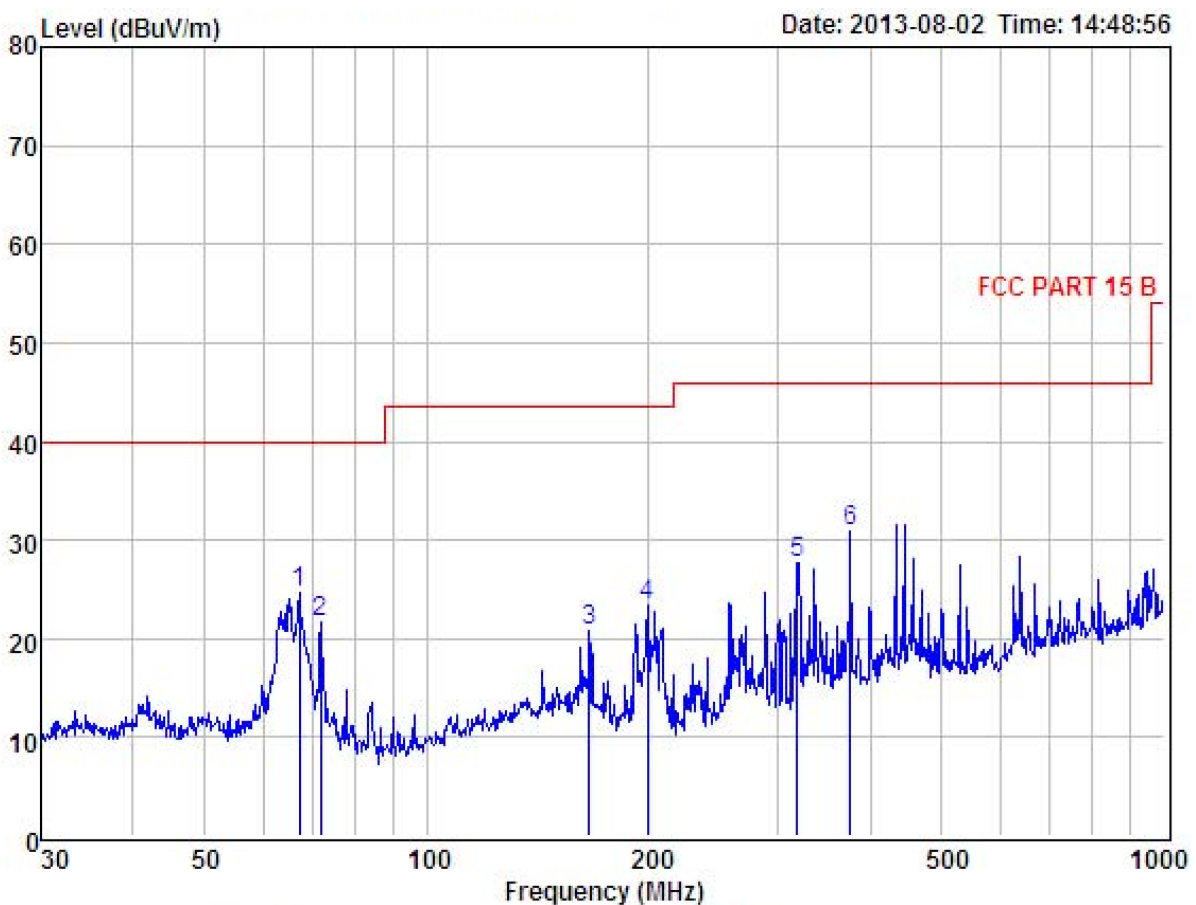

Item	Freq MHz	Read Level dBuV	Antenna Factor dB	Preamp Factor dB	Cable Loss dB	Level dBuV	Limit dBuV	Margin dBuV	Remark
1	67.20	40.06	11.21	26.98	0.28	24.57	40.00	-15.43	Peak
2	71.83	37.76	10.51	26.77	0.19	21.69	40.00	-18.31	Peak
3	166.07	33.67	13.56	26.92	0.39	20.70	43.50	-22.80	Peak
4	199.29	39.92	9.90	26.97	0.43	23.28	43.50	-20.22	Peak
5	317.70	41.06	13.24	27.22	0.61	27.69	46.00	-18.31	Peak
6	375.94	43.01	14.35	27.35	0.96	30.97	46.00	-15.03	Peak

Remark: Level = Read Level + Antenna Factor - Preamp Factor + Cable Loss

Operation Mode:	TX 2450 MHz	Test Date :	August 02, 2013
Frequency Range:	30~1000MHz	Temperature :	28 °C
Measured Distance:	3m	Humidity :	65 %
Test Voltage:	DC 3.0V		
Ant. Pol.	Vertical		

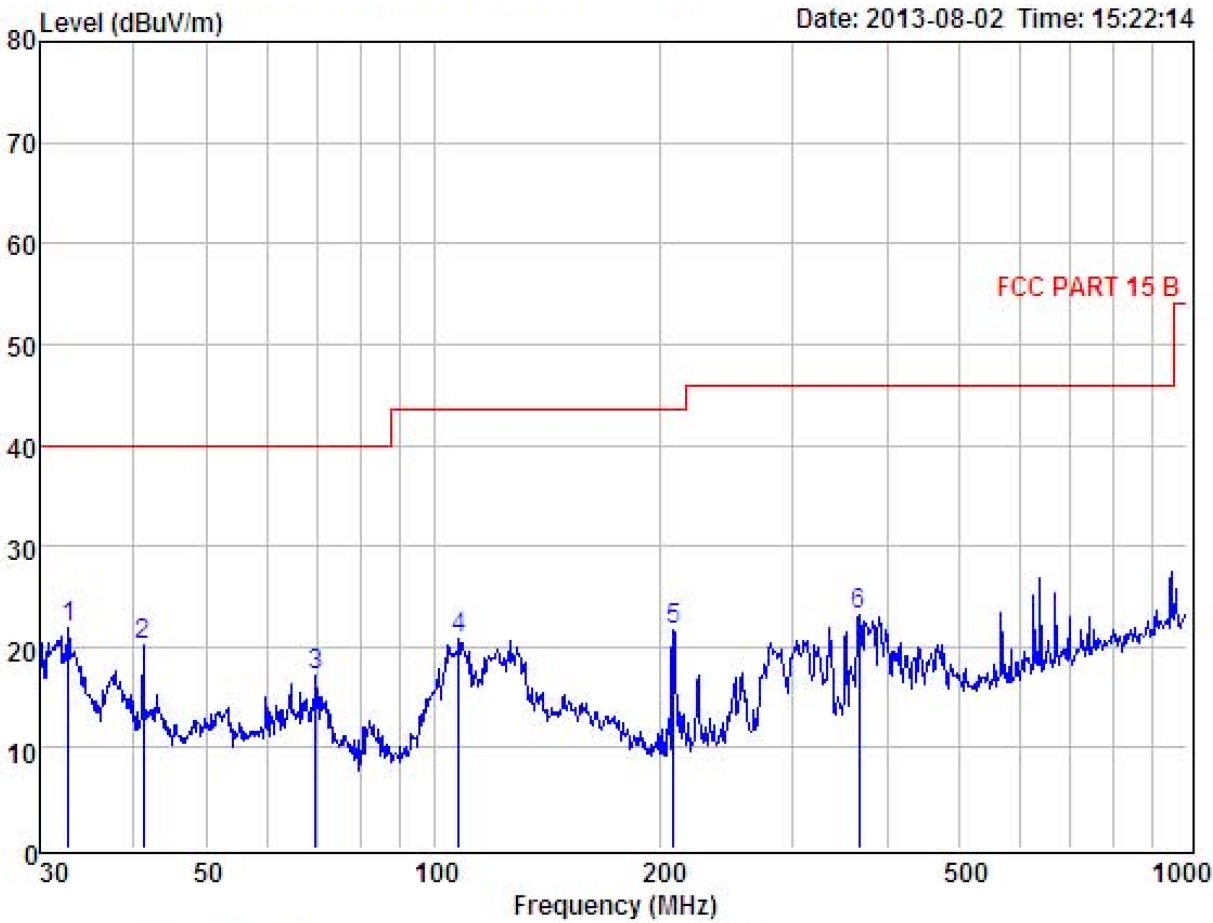

Item	Freq MHz	Read Level dBuV	Antenna Factor dB	Preamp Factor dB	Cable Loss dB	Level dBuV	Limit dBuV	Margin dBuV	Remark
1	32.75	35.96	13.28	27.51	0.11	21.84	40.00	-18.16	Peak
2	41.13	33.92	13.93	27.81	0.18	20.22	40.00	-19.78	Peak
3	69.84	32.89	10.82	26.76	0.24	17.19	40.00	-22.81	Peak
4	107.89	36.29	10.93	26.86	0.44	20.80	43.50	-22.70	Peak
5	207.85	38.24	10.04	27.01	0.49	21.76	43.50	-21.74	Peak
6	366.82	35.35	14.16	27.32	0.87	23.06	46.00	-22.94	Peak

Harmonics emissions

Operation Mode: TX 2450 MHz Test Date : August 02, 2013
 Frequency Range: 1-25GHz Temperature : 28 °C
 Measured Distance: 3m Humidity : 65 %
 Test Voltage: DC 3.0V

Freq. (MHz)	Ant.Pol. H/V	Emission Level (dBuV/m)		Limit3m (dBuV/m)		Margin (dB)	
		PK	AV	PK	AV	PK	AV
4899.900	V	59.76	47.00	74.00	54.00	14.24	7.00
7349.800	V	53.68	40.92	74.00	54.00	20.32	13.08
--	V	--	--	74.00	54.00	--	--
--	V	--	--	74.00	54.00	--	--
--	V	--	--	74.00	54.00	--	--
4899.900	H	57.45	44.69	74.00	54.00	44.69	9.31
7349.800	H	51.09	38.33	74.00	54.00	22.91	15.67
--	H	--	--	74.00	54.00	--	--
--	H	--	--	74.00	54.00	--	--
--	H	--	--	74.00	54.00	--	--

Other harmonics emissions are lower than 20dB below the allowable limit.

- Note:**
- (1) All Readings are Peak Value and AV.
 - (2) Emission Level= Reading Level + Probe Factor +Cable Loss
 - (3) Data of measurement within this frequency range shown "--" in the table above means the reading of emissions are attenuated more than 20dB below the permissible limits or the field strength is too small to be measured.
 - (4) For above 1GHz radiated emissions
 Peak value set RBW/VBW: 1MHz/3MHz;
 Average =Peak-12.76

5. Restricted Bands Requirement

5.1 Test Standard and Limit

5.1.1 Test Standard

FCC Part 15.209

FCC Part 15.205

5.1.2 Test Limit

Restricted Frequency Band (MHz)	Class B (dBuV/m)(at 3 M)
2310~2390	Attenuated by at least 50 dB below the level of the fundamental or to the general radiated emission limits in 15.209, whichever is the lesser attenuation
2483.5~2500	

5.2 Test Setup

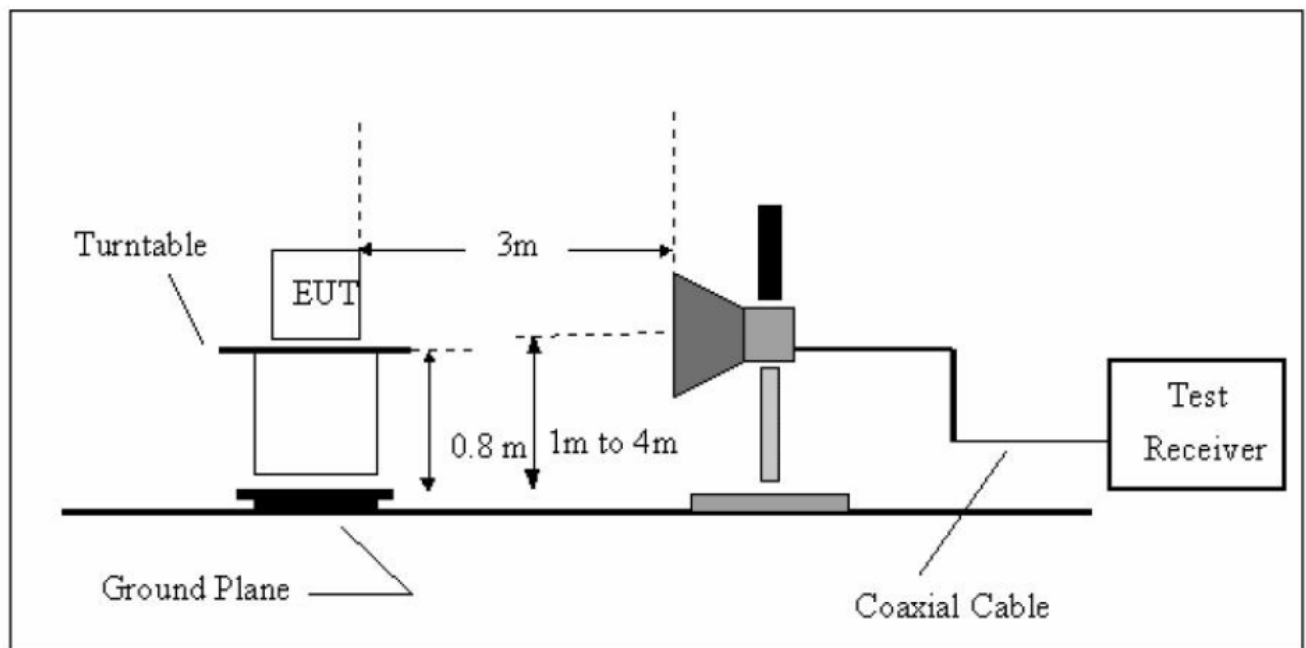

5.3 Test Procedure

- (1) The measuring distance of 3m shall be used for measurements at frequency up to 1GHz and above 1 GHz. The EUT was placed on a rotating 0.8m high above ground, the table was rotated 360 degrees to determine the position of the highest radiation.
- (2) The Test antenna shall vary between 1m and 4m, Both Horizontal and Vertical antenna are set to make measurement.
- (3) The initial step in collecting conducted emission data is a spectrum analyzer peak detector

mode pre-scanning the measurement frequency range. Significant peaks are then marked and then Quasi Peak detector mode re-measured.

- (4) If the Peak Mode measured value compliance with and lower than Quasi Peak Mode Limit Bellow 1 GHz, the EUT shall be deemed to meet QP Limits and then no additional QP Mode measurement performed. But the Peak Value and average value both need to comply with applicable limit above 1 GHz.
- (5) For the actual test configuration, please see the test setup photo.

5.4 EUT Operating Condition

The Equipment Under Test was set to Continual Transmitting in maximum power.

5.5 Test Equipment

Description	Manufacturer	Model No.	Serial No.	Cal. Date	Cal. Due Date
Spectrum Analyzer	ROHDE& SCHWARZ	FSP30	DE25181	2012-12-31	2013-12-30
Spectrum Analyzer	Agilent	E4407B	MY49510055	2012-12-31	2013-12-30
EMI Test Receiver	ROHDE& SCHWARZ	ESCI	101165	2012-12-31	2013-12-30
Bilog Antenna	SCHWARZBECK	VULB9168	9168-438	2013-02-12	2014-02-11
Horn Antenna	SCHWARZBECK	BBHA 9120D	BBHA9120D	2013-02-12	2014-02-11
Horn Antenna	SCHWARZBECK	BBHA 9170	BBHA9170D	2013-02-12	2014-02-11
Active Loop Antenna	Beijing Daze	ZN30900A	SEL0097	2013-02-12	2014-02-11
Pre-amplifier	SCHWARZBECK	BBV9743	9743-019	2012-10-31	2013-10-30
Pre-amplifier	Quietek	AP-180C	CHM-0602012	2012-10-31	2013-10-30

5.6 Test Data

Spectrum Detector: PK Test Date : August 02, 2013
 Temperature : 28 °C Humidity : 65 %

1. Lower Band Edge

Freq. (MHz)	Ant.Pol. H/V	Emission Level (dBuV/m)		Limit3m (dBuV/m)		Margin (dB)	
		PK	AV	PK	AV	PK	AV
2310.000	V	42.53	29.77	74.00	54.00	31.47	24.23
2390.000	V	45.58	32.82	74.00	54.00	28.42	21.28
2310.000	H	36.25	23.49	74.00	54.00	37.75	30.51
2390.000	H	39.57	26.81	74.00	54.00	34.43	27.19

2. Upper Band Edge

Freq. (MHz)	Ant.Pol. H/V	Emission Level (dBuV/m)		Limit3m (dBuV/m)		Margin (dB)	
		PK	AV	PK	AV	PK	AV
2483.500	V	48.46	35.70	74.00	54.00	25.54	18.30
2500.000	V	41.11	28.53	74.00	54.00	32.89	25.65
2483.500	H	46.38	33.62	74.00	54.00	27.62	20.38
2500.000	H	40.25	27.49	74.00	54.00	33.75	26.51

6. Bandwidth Test

6.1 Test Setup

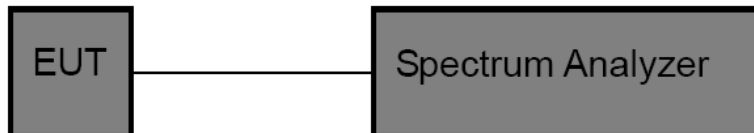

6.2 Test Procedure

- (1) The EUT was directly connected to the spectrum analyzer and antenna output port as show in the block diagram above.
- (2) Spectrum Setting:
 - Bandwidth: RBW=100 kHz, VBW=100 kHz for bellow 1GHz.
 - Bandwidth: RBW=100 kHz, VBW=300 kHz for above 1GHz.
- (3) The bandwidth is measured at an amplitude level reduced 20dB from the reference level. The reference level is the level of the highest amplitude signal observed from the transmitter at the fundamental frequency. Once the reference level is established, the equipment is conditioned with typical modulating signal to produce the worst –case (i.e the widest) bandwidth.

6.3 EUT Operating Condition

The EUT was set to continuously transmitting for the Bandwidth Test.

6.4 Test Equipment

Description	Manufacturer	Model No.	Serial No.	Cal. Date	Cal. Due Date
Spectrum Analyzer	ROHDE& SCHWARZ	FSP30	DE25181	2012-12-31	2013-12-30

6.5 Test Data

Channel number	Channel frequency (MHz)	20dB Bandwidth (KHz)
CH 1	2450	1000

2450 MHz

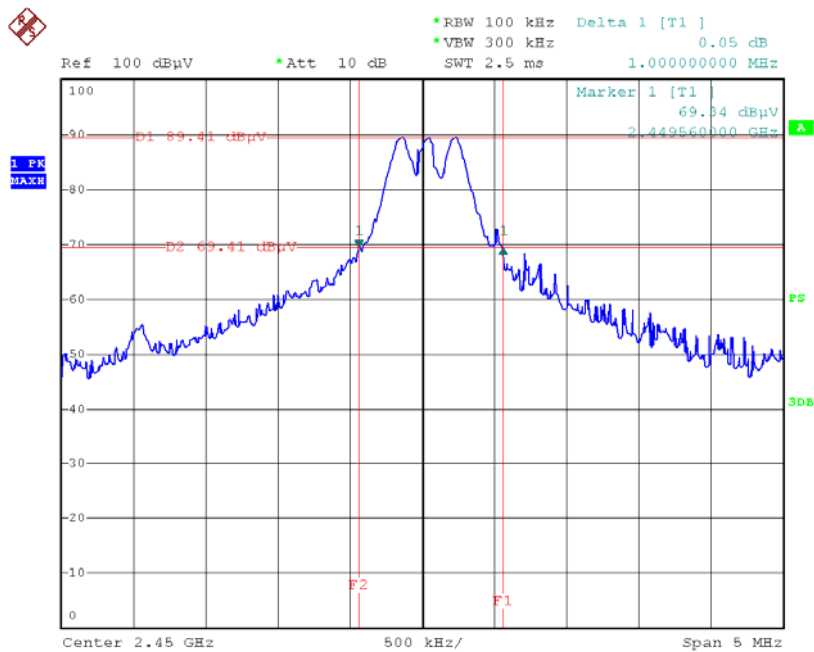

Date: 3.AUG.2013 15:37:14

7. Antenna Requirement

7.1 Standard Requirement

7.1.1 Standard

FCC Part 15.203

7.1.2 Requirement

An intentional radiator shall be designed to ensure that no antenna other than that furnished by the responsible party shall be used with the device. The use of a permanently attached antenna or of an antenna that uses a unique coupling to the intentional radiator shall be considered sufficient to comply with the provisions of this Section. The manufacturer may design the unit so that a broken antenna can be replaced by the user, but the use of a standard antenna jack or electrical connector is prohibited.

7.2 Antenna Connected Construction

The directional gains of the antenna used for transmitting is 0 Bi, and the antenna de-signed with permanent attachment and no consideration of replacement. Please see the EUT photo for details.

7.3 Result

The EUT antenna is a Printed Antenna. It complies with the standard requirement.