

TEST REPORT

Applicant:	Guoguang Electric Co., Ltd.
Address of Applicant:	No.8 Jinghu Road, Xinhua Street, Huadu Reg, Guangzhou, China
Manufacturer:	MEIZU Technology Co., Ltd.
Address of Manufacturer:	MEIZU Tech Bldg., Technology & Innovation Coast Zhuhai, 519085, Guangdong, China
Product name:	Meizu wireless speaker
Model:	Gravity A8
Rating(s):	Rated Input: 15Vdc, 3.0A (For main); 100V-240V~, 50/60Hz, 1.5A (For AC Adapter); Rated Output: 15Vdc, 3.0A (For AC Adapter)
Trademark:	MEIZU
Standards:	47 CFR PART 15 Subpart C: 2016 section 15.247
FCC ID:	2AAP8GRAVITYA8
Data of Receipt:	2016-11-21
Date of Test:	2016-11-21~2017-01-13
Date of Issue:	2017-01-16
Test Result	Pass*

* In the configuration tested, the test item complied with the standards specified above.

Authorized for issue by:**Test by:****Reviewed by:**

Jan.16, 2017 Eleven Liang

Jan.16, 2017

Pauler Li

Project Engineer

Project Engineer

Date

Name/Position

Signature

Date

Name/Position

Signature

Possible test case verdicts:

test case does not apply to the test object ...: N/A
test object does meet the requirement: P (Pass)
test object does not meet the requirement ...: F (Fail)

Testing Laboratory information:

Testing Laboratory Name: I-Test Laboratory
Address.....: 1-2 floor, South Block, Building A2 , No 3 Keyan Lu,
Science City, Guangzhou, Guangdong Province, P.R. China
Testing location : Same as above
Tel : 0086-20-32209330
Fax : 0086-20-62824387
E-mail : itl@i-testlab.com

General remarks:

The test results presented in this report relate only to the object tested.

The results contained in this report reflect the results for this particular model and serial number. It is the responsibility of the manufacturer to ensure that all production models meet the intent of the requirements detailed within this report.

This report would be invalid test report without all the signatures of testing technician and approver.

This report shall not be reproduced, except in full, without the written approval of the Issuing testing laboratory.

Note:

/

1 Test Summary

Test	Test Requirement	Test method	Result
Antenna Requirement	FCC PART 15 C section 15.247 (c) and Section 15.203	FCC PART 15 C section 15.247 (c) and Section 15.203	PASS
6 dB Bandwidth	FCC PART 15 C section 15.247 (a)(2)	ANSI C63.10:2013 Clause 6.9	PASS
Maximum Peak Output Power	FCC PART 15 C section 15.247(b)(3)	ANSI C63.10: 2013 Clause 6.10	PASS
Peak Power Spectral Density	FCC PART 15 C section 15.247(e)	ANSI C63.10:2013 Clause 6.11	PASS
Conducted Spurious Emission (30MHz to 25GHz)	FCC PART 15 C section 15.209 &15.247(d)	ANSI C63.10:2013 Clause 6.7	PASS
Radiated Spurious Emission (30 MHz to 25 GHz)	FCC PART 15 C section 15.209 &15.247(d)	ANSI C63.10:2013 Clause 6.4, 6.5	PASS
Band Edges Measurement	FCC PART 15 C section 15.247 (d) &15.205	ANSI C63.10:2013 Clause 6.9	PASS
Conducted Emissions at Mains Terminals	FCC PART 15 C section 15.207	ANSI C63.10:2013 Clause 6.2	PASS

2 Contents

	Page
TEST REPORT	1
1 TEST SUMMARY	3
2 CONTENTS	4
3 GENERAL INFORMATION	5
3.1 CLIENT INFORMATION	5
3.2 GENERAL DESCRIPTION OF E.U.T.	5
3.3 DETAILS OF E.U.T.	5
3.4 DESCRIPTION OF SUPPORT UNITS	6
3.5 TEST LOCATION	6
3.6 DEVIATION FROM STANDARDS	6
3.7 ABNORMALITIES FROM STANDARD CONDITIONS	6
3.8 OTHER INFORMATION REQUESTED BY THE CUSTOMER	6
3.9 TEST FACILITY	6
3.10 MEASUREMENT UNCERTAINTY	6
4 INSTRUMENTS USED DURING TEST	7
5 TEST RESULTS	8
5.1 E.U.T. TEST CONDITIONS	8
5.2 ANTENNA REQUIREMENT	10
5.3 6 DB BANDWIDTH	11
5.4 MAXIMUM PEAK OUTPUT POWER	14
5.4.1 <i>Method of measurement</i>	<i>14</i>
5.4.2 <i>Test results</i>	<i>14</i>
5.5 PEAK POWER SPECTRAL DENSITY	15
5.6 CONDUCTED SPURIOUS EMISSIONS	19
5.7 RADIATED SPURIOUS EMISSIONS	22
5.7.1 <i>Harmonic and other spurious emissions</i>	<i>25</i>
5.8 RADIATED EMISSIONS WHICH FALL IN THE RESTRICTED BANDS	34
5.9 BAND EDGES REQUIREMENT	38
5.10 CONDUCTED EMISSIONS AT MAINS TERMINALS 150 KHZ TO 30MHZ	41
5.10.1 <i>Measurement Data</i>	<i>43</i>

3 General Information

3.1 Client Information

Applicant: Guoguang Electric Co., Ltd.
 Address of Applicant: No.8 Jinghu Road, Xinhua Street, Huadu Reg, Guangzhou, China

3.2 General Description of E.U.T.

Name: Meizu wireless speaker
 Model No.: Gravity A8
 Trade Mark: MEIZU
 Operating Frequency: 2402 MHz to 2480 MHz for bluetooth
 Bluetooth Version: 4.0
 This report is for BLE mode.
 40 channels with 2MHz step

Channels:

channel	Frequency	channel	Frequency	channel	Frequency	channel	Frequency
1	2402	11	2422	21	2442	31	2462
2	2404	12	2424	22	2444	32	2464
3	2406	13	2426	23	2446	33	2466
4	2408	14	2428	24	2448	34	2468
5	2410	15	2430	25	2450	35	2470
6	2412	16	2432	26	2452	36	2472
7	2414	17	2434	27	2454	37	2474
8	2416	18	2436	28	2456	38	2476
9	2418	19	2438	29	2458	39	2478
10	2420	20	2440	30	2460	40	2480

Type of Modulation: GFSK for Bluetooth
 Function: wireless speaker
 Antenna Type: FPC antenna
 Antenna gain: 2.91 dBi
 Hardware version: V03
 Software version: V0.42

3.3 Details of E.U.T.

EUT Power Supply: Rated Input: 15Vdc, 3.0A (For main);
 100V-240V~, 50/60Hz, 1.5A (For AC Adapter);
 Rated Output: 15Vdc, 3.0A (For AC Adapter)
 Test mode: The program used to control the EUT for staying in continuous transmitting and receiving mode is programmed. Channel lowest (2402MHz), middle (2440MHz) and highest (2480MHz) are chosen for full testing.
 Power cord: Direct plug
 Manufacturer: MEIZU Technology Co., Ltd.
 Model number: Gravity A8
 Input/output voltage: Rated Input: 15Vdc, 3.0A (For main);

range: 100V-240V~, 50/60Hz, 1.5A (For AC Adapter);
Rated Output: 15Vdc, 3.0A (For AC Adapter)

3.4 Description of Support Units

The EUT has been tested as an independent unit for fixed frequency by testing lab.

Details of Support Equipment(s)

Description	Manufacturer	Model No.	Connection	Working state
Portable computer	Lenovo	E431	USB line	Normal working

3.5 Test Location

All tests were performed at:

I-Test Laboratory

1-2 floor, South Block, Building A2 , No 3 Keyan Lu, Science City, Guangzhou, Guangdong Province, P.R. China

0086-20-32209330

itl@i-testlab.com

No tests were sub-contracted.

3.6 Deviation from Standards

Biconical and log periodic antennas were used instead of dipole antennas.

3.7 Abnormalities from Standard Conditions

None.

3.8 Other Information Requested by the Customer

None.

3.9 Test Facility

The test facility is recognized, certified, or accredited by the following organizations:

- CNAS(Lab code:L4957)
- FCC (Registration No.:935596)
- IC (Registration NO.:8368A)

3.10 Measurement Uncertainty

The below measurement uncertainties given below are based on a 95% confidence level (base on a coverage factor (k=2).)

Parameter	Uncertainty
Radio frequency	$\pm 1.06 \times 10^{-7}$
total RF power, conducted	1.37 dB
RF power density , conducted	2.89 dB
All emissions, radiated	± 3.35 dB
Temperature	± 0.23 °C
Humidity	± 0.3 %
DC and low frequency voltages	± 0.3 %

4 Instruments Used during Test

No.	Test Equipment	Manufacturer	Model	Serial No.	Last Cal.	Cal. Due
ITL-114	Spectrum Analyzer	Agilent	N9010A	MY51250936	2016/01/25	2017/01/25
ITL-154	EMI test receiver 9kHz to 26.5GHz	R&S	ESR26	101257	2016/01/25	2017/01/25
ITL-116	Pre Amplifier	HP	8447F	3113A05905	2016/01/25	2017/01/25
ITL-117	Wideband Amplifier Super Ultra	Mini-circuits	ZVA-183- S+	469101134	2016/01/25	2017/01/25
ITL-105	Biconilog Antenna	ETS•Lindgren	3142D	00108096	2015/01/24	2018/01/24
ITL-110	Horn Antenna	A-INFOMW	JXTXLB- 10180-N	J2031090612 133	2015/01/24	2018/01/24
ITL-102	EMI Test receiver	R&S	ESCI	100910	2016/06/17	2017/06/17
ITL-103	Two-line v- network	R&S	ENV216	100120	2016/06/17	2017/06/17
ITL-115	50Ω Coaxial Cable	Mini-circuits	CBL	C001	2016/06/17	2017/06/17
ITL-100	Semi-Anechoic chamber	ETS•Lindgren	FACT3 2.0	CT09015	2014/06/17	2017/06/17
ITL-145	Loop Antenna	ZHINAN	ZN30900 A	002489	2016/01/25	2017/01/25
ITL-146	Horn Antenna	Schwarzbeck	BBHA 9170	B09806543	2016/06/17	2017/06/17
ITL-101	Shielded Room	ETS•Lindgren	8*4*3	CT09010	2015/03/09	2018/03/09

5 Test Results

5.1 E.U.T. test conditions

Test Voltage: AC 120V
Temperature: 23.2 -25.0 °C
Humidity: 38-50 % RH
Atmospheric Pressure: 1000 -1010 mbar

Requirements: **15.31(e):** For intentional radiators, measurements of the variation of the input power or the radiated signal level of the fundamental frequency component of the emission, as appropriate, shall be performed with the supply voltage varied between 85% and 115% of the nominal rated supply voltage. For battery operated equipment, the equipment tests shall be performed using a new battery.
15.32: Power supplies and CPU boards used with personal computers and for which separate authorizations are required to be obtained shall be tested as follows: Testing shall be in accordance with the procedures specified in Section 15.31 of this part.

Test frequencies and frequency range: According to the 15.31(m) Measurements on intentional radiators or receivers, other than TV broadcast receivers, shall be performed and, if required, reported for each band in which the device can be operated with the device operating at the number of frequencies in each band specified in the following table:

According to the 15.33 (a) For an intentional radiator, the spectrum shall be investigated from the lowest radio frequency signal generated in the device, without going below 9 kHz, up to at least the frequency shown in the following table:

Number of fundamental frequencies to be tested in EUT transmit band

Frequency range in which	Number of	Location in frequency range
1 MHz or less	1	Middle
1 MHz to 10 MHz	2	1 near top and 1 near bottom
More than 10 MHz	3	1 near top, 1 near middle and 1 near bottom

Frequency range of radiated emission measurements

Lowest frequency generated	Upper frequency range of measurement
9 kHz to below 10 GHz	10th harmonic of highest fundamental frequency or to 40 GHz,
At or above 10 GHz to below	5th harmonic of highest fundamental frequency or to 100 GHz,
At or above 30 GHz	5th harmonic of highest fundamental frequency or to 200 GHz,

EUT channels and frequencies list:

channel	Frequency	channel	Frequency	channel	Frequency	channel	Frequency
1	2402	11	2422	21	2442	31	2462
2	2404	12	2424	22	2444	32	2464
3	2406	13	2426	23	2446	33	2466
4	2408	14	2428	24	2448	34	2468
5	2410	15	2430	25	2450	35	2470
6	2412	16	2432	26	2452	36	2472
7	2414	17	2434	27	2454	37	2474
8	2416	18	2436	28	2456	38	2476
9	2418	19	2438	29	2458	39	2478
10	2420	20	2440	30	2460	40	2480

Test frequencies are the lowest channel: 1 channel (2402MHz), middle channel: 20 channel (2440 MHz) and highest channel: 40 channel (2480 MHz)

Test the EUT in continuous transmission mode, duty cycle > 98%.

5.2 Antenna requirement

Standard requirement

15.203 requirement:

For intentional device. According to 15.203. An intentional radiator shall be designed to Ensure that no antenna other than that furnished by the responsible party shall be used with the device.

15.247(c) (1)(i) requirement:

(i) Systems operating in the 2400-2483.5 MHz bands that are used exclusively for fixed. Point-to-point operations may employ transmitting antennas with directional gain greater than 6 dBi provided the maximum conducted output power of the intentional radiator is reduced by 1 dB for every 3 dB that the directional gain of the antenna exceeds 6 dBi.

EUT Antenna

The antenna is a FPC antenna and no consideration of replacement. The best case gain of the antenna is 2.91dBi.

Test result: The unit does meet the FCC requirements.

5.3 6 dB Bandwidth

Test Requirement:	FCC Part 15 C section 15.247 (a)(2) Systems using digital modulation techniques may operate in the 902-928 MHz, 2400-2483.5MHz, and 5725-5850 MHz bands. The minimum 6 dB bandwidth shall be at least 500 kHz.
Test Method:	ANSI C63.10:2013 Clause 6.9
Test Status:	Pre-Scan has been conducted to determine the worst-case mode from all possible combinations between available modulations, channels and antenna ports (if EUT with antenna diversity architecture). Following channel(s) was (were) selected for the final test as listed below.

Test Configuration:

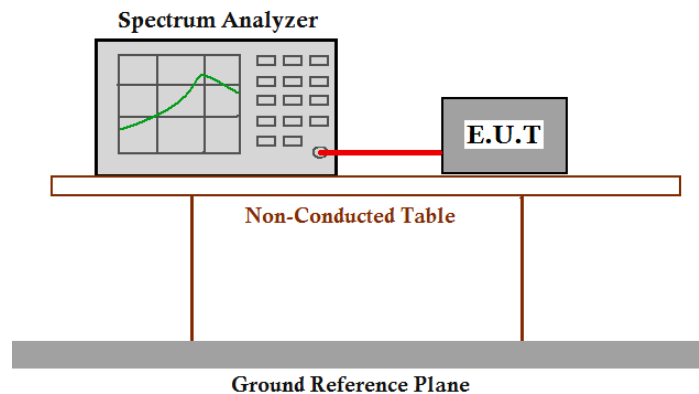

Test Procedure:

1. Remove the antenna from the EUT and then connect a low attention attenuation RF cable (Cable loss =0.5dB) from the antenna port to the spectrum.
2. Set the spectrum analyzer: RBW=100kHz. VBW = 300kHz, Sweep = auto; Detector Function = Peak. Trace = Max Hold, Set span to encompass the entire emission bandwidth of the signal.
3. Mark the peak power frequency and -6dB (upper and lower) power frequency.
4. Repeat until all the test status is investigated.
5. Report the worst case.

Channel No.	Frequency (MHz)	Measured 6dB bandwidth (MHz)	Limit	Result
1	2402	0.707	≥500KHz	Pass
20	2440	0.712		Pass
40	2480	0.700		Pass

6dB bandwidth:

Result plot as follows:

Channel 1:2.402GHz:

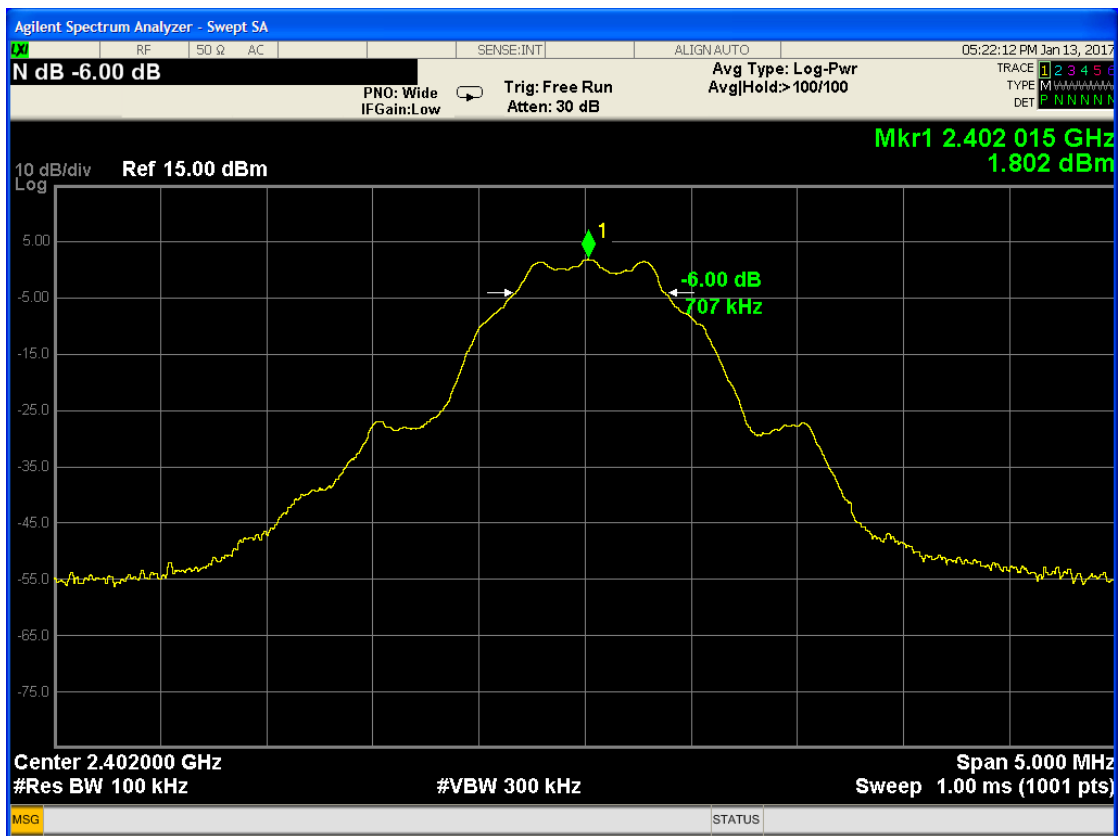

Channel 20:2.440GHz:

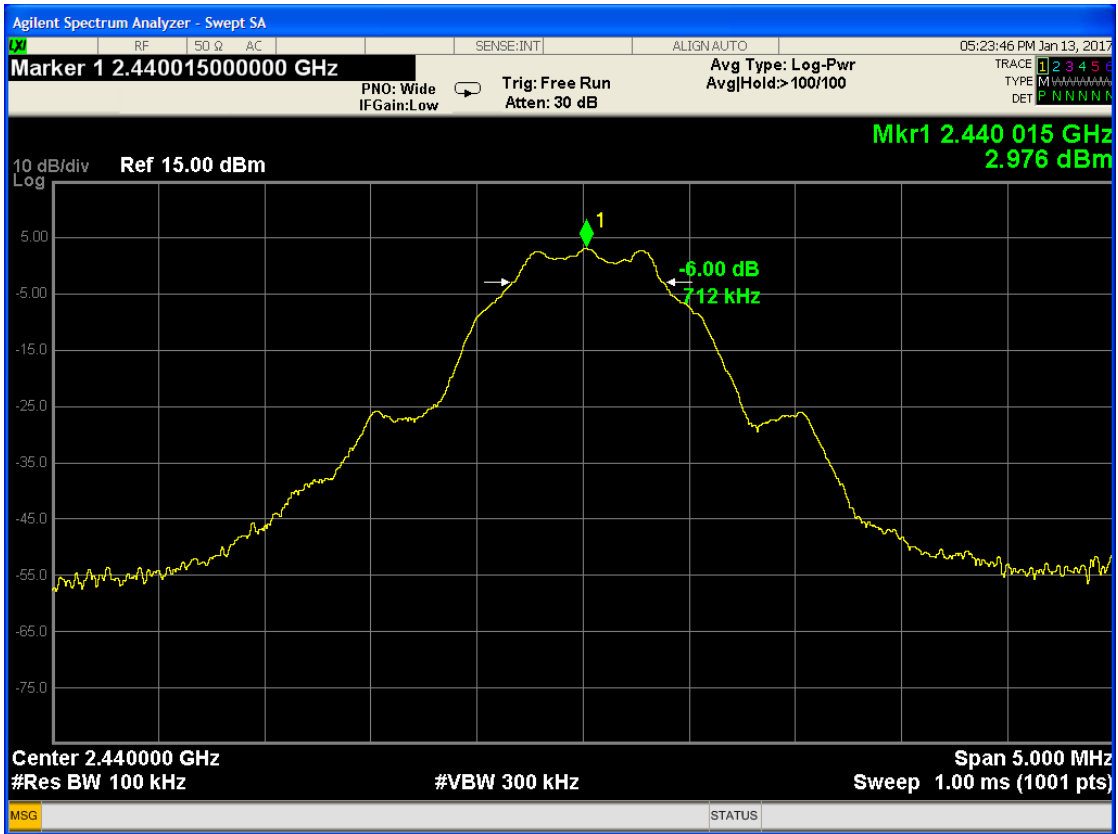

Channel 40:2.480GHz:

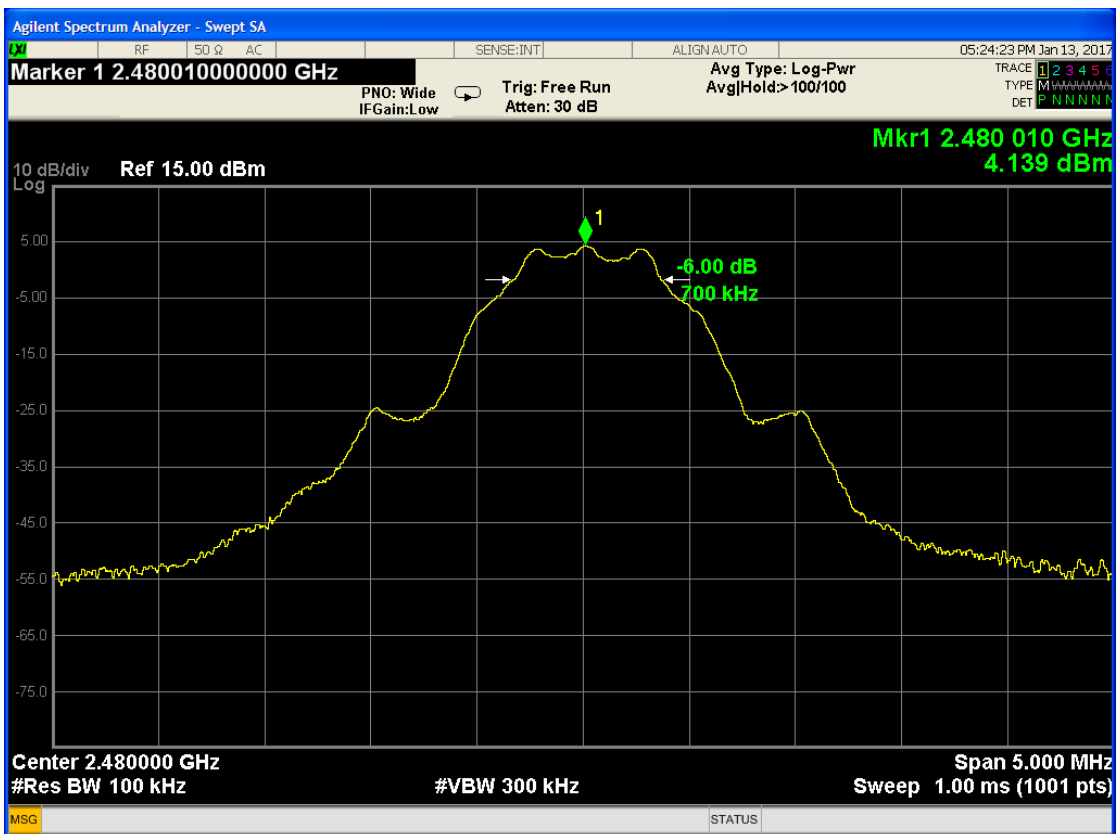

5.4 Maximum Peak Output Power

5.4.1 Method of measurement

The EUT has to be connected to the power meter via a loss cable.

The measurement procedures described here in are based on the use of an antenna-port conducted test configuration.

PKPM1-Peak power meter method was used for this test.

The measurement was performed at the upper and lower end and the middle of the assigned frequency band.

Test set-up:



5.4.2 Test results

Channel No.	Frequency (MHz)	Measured Power (dBm)	Limit (dBm)	Result
1	2402	3.45	30	Pass
20	2440	4.70		Pass
40	2480	5.29		Pass
Remark: cable loss=0.5dB				

The unit does meet the FCC requirements.

5.5 Peak Power Spectral Density

Test Requirement: FCC Part 15 C section 15.247
(e) For digitally modulated systems, the power spectral density conducted from the intentional radiator to the antenna shall not be greater than 8 dBm in any 3 kHz band during any time interval of continuous transmission. This power spectral density shall be determined in accordance with the provisions of paragraph (b) of this section. The same method of determining the conducted output power shall be used to determine the power spectral density.

Test Method: ANSI C63.10:2013 Clause 6.11

Test Status: Pre-Scan has been conducted to determine the worst-case mode from all possible combinations between available modulations, channel and antenna ports (if EUT with antenna diversity architecture). Following channel(s) was (were) selected for the final test as listed below.

Test Configuration:

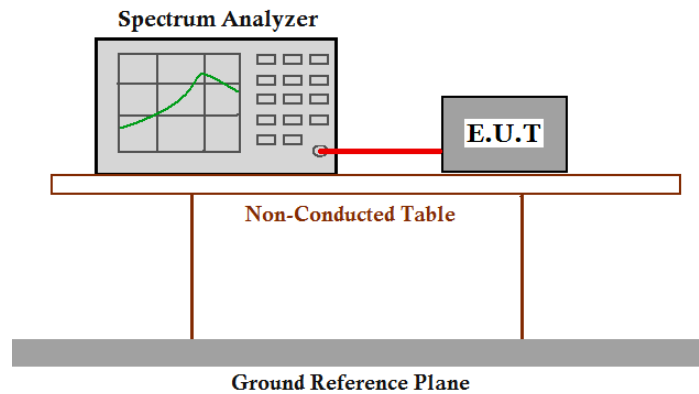

Test Procedure:

1. Remove the antenna from the EUT and then connect a low attention attenuation RF cable
(Cable loss =0.5 dB) from the antenna port to the spectrum analyzer or power meter.
2. Set the spectrum analyzer:
 - a) Set CENTER FREQUENCY = Frequency from Power Spectral Density Test Matrix (see 6.10.2)
 - b) Set SPAN = 20 MHz (For devices with a nominal 40 MHz BW, 50 MHz span will be needed)
 - c) Set REFERENCE LEVEL = 15 dBm
 - d) Set ATTENUATION = 0 dB (add internal attenuation, if necessary)
 - e) Set SWEEP TIME = Coupled
 - f) Set RBW = 3 kHz
 - g) Set VBW = 3 MHz
 - h) Set DETECTOR = Peak
 - i) Set MKR = Center Frequency
 - j) Set TRACE = CLEAR WRITE

Place the radio in continuous transmit mode. Set the TRACE to MAX HOLD, and after the trace stabilizes, the TRACE to VIEW. Set the marker on the peak of the signal and then adjust the center frequency of the spectrum analyzer to the marker frequency.

After viewing the EUT waveform on the spectrum analyzer, perform the following spectrum analyzer functions to capture the trace:

Set SPAN = 2 MHz
Set SWEEP TIME = 100 s
Set TRACE = MAX HOLD
Set MKR = PEAK SEARCH

3. Measure the Power Spectral Density of the test frequency with special test status.
4. Repeat until all the test status is investigated.
5. Report the worse case.

Test result:

Channel No.	Frequency (MHz)	Measured Peak Power Spectral Density (dBm/3kHz)	Limit	Result
1	2402	-10.74	8dBm/3kHz	Pass
20	2440	-9.52		Pass
40	2480	-8.56		Pass
Remark: cable loss=0.5dB				

Test result: Level = Read Level + Cable Loss.
 The results does meet the FCC requirements.

Result plot as follows:

Channel 1:2.402 GHz:

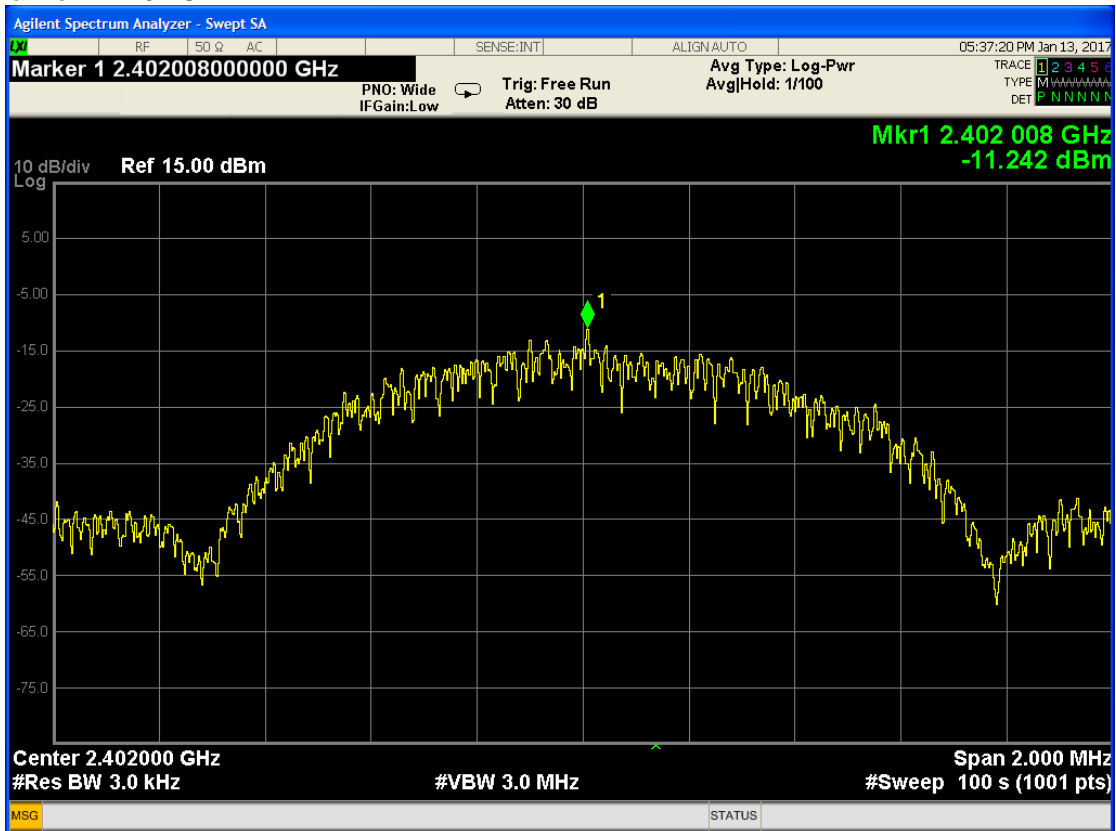

Channel 20:2.440GHz:

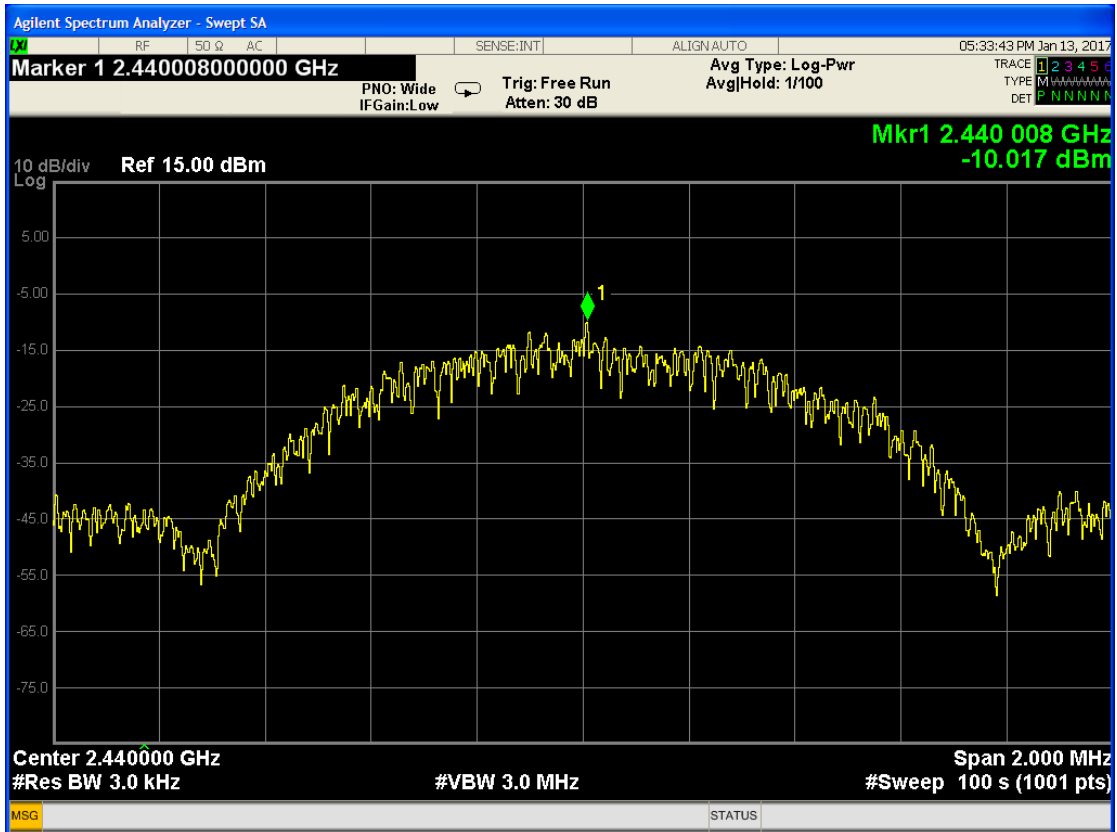

Channel 40:2.480 GHz:

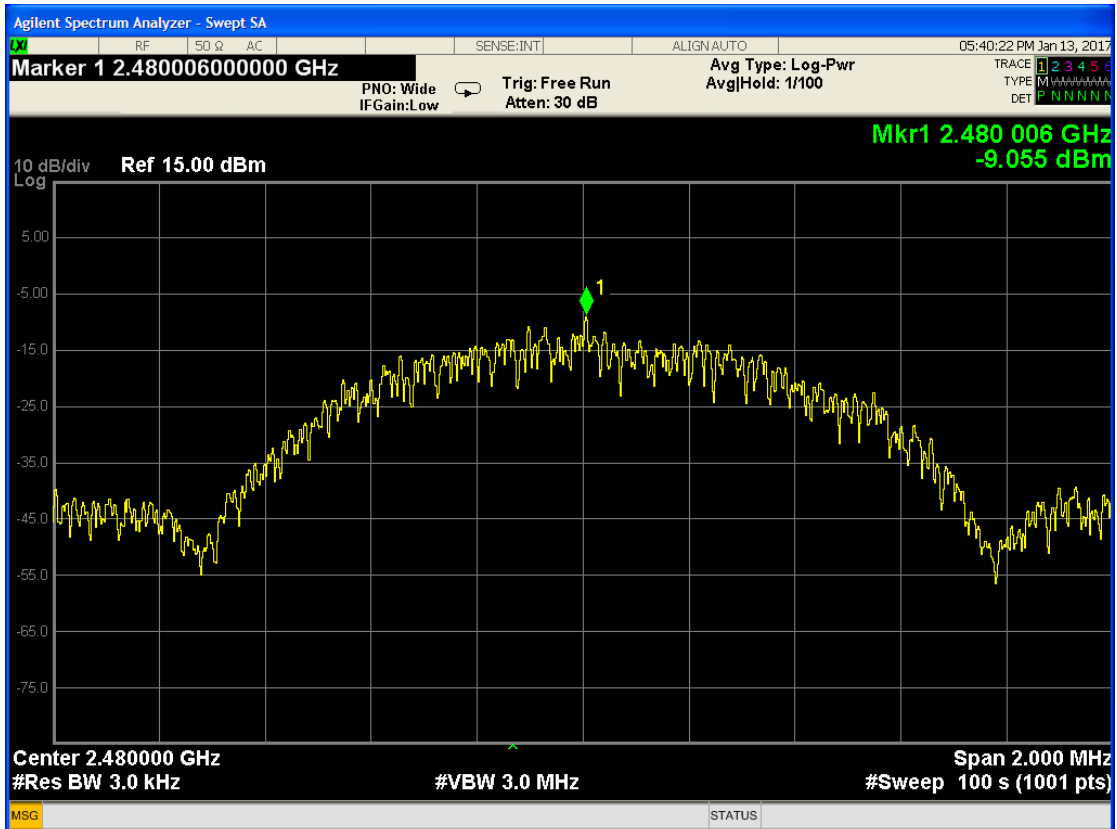

5.6 Conducted Spurious Emissions

Test Requirement: FCC Part 15 C section 15.247

(d) In any 100 kHz bandwidth outside the frequency band in which the spread spectrum or digitally modulated intentional radiator is operating, the radio frequency power that is produced by the intentional radiator shall be at least 20 dB below that in the 100 kHz bandwidth within the band that contains the highest level of the desired power. Based on either an RF conducted or a radiated measurement. Provided the transmitter demonstrates compliance with the peak conducted power limits.

Test Method: ANSI C63.10:2013 Clause 6.7

Test Status: Pre-Scan has been conducted to determine the worst-case mode from all possible combinations between available modulations, channel and antenna ports (if EUT with antenna diversity architecture). Following channel(s) was (were) selected for the final test as listed below.

Test Configuration:

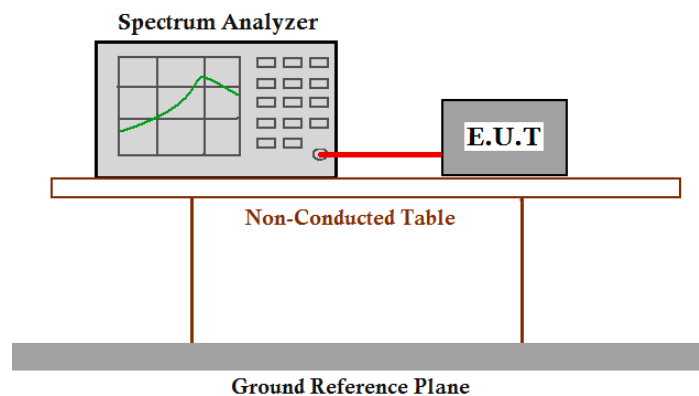

Test Procedure:

1. Remove the antenna from the EUT and then connect a low RF cable from the antenna port to the spectrum analyzer or power meter.
2. Set the spectrum analyzer: RBW=100 KHz, VBW = 300KHz. Sweep = auto; Detector Function = Peak. Trace = Max Hold, Scan up through 10th harmonic.
3. Measure the Conducted Spurious Emissions of the test frequency with special test status.
4. Repeat until all the test status is investigated.
5. Report the worse case.

Result plot as follows:

Channel 1: 2.402 GHz

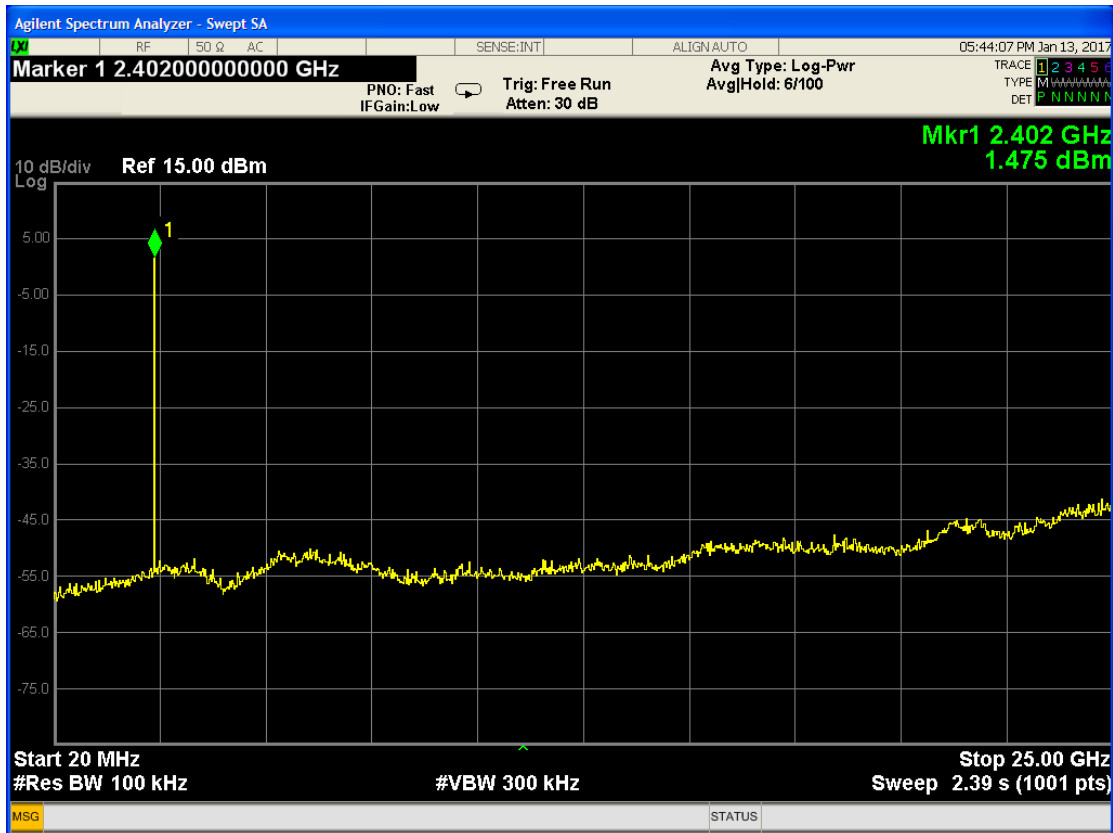

Channel 20: 2.440 GHz

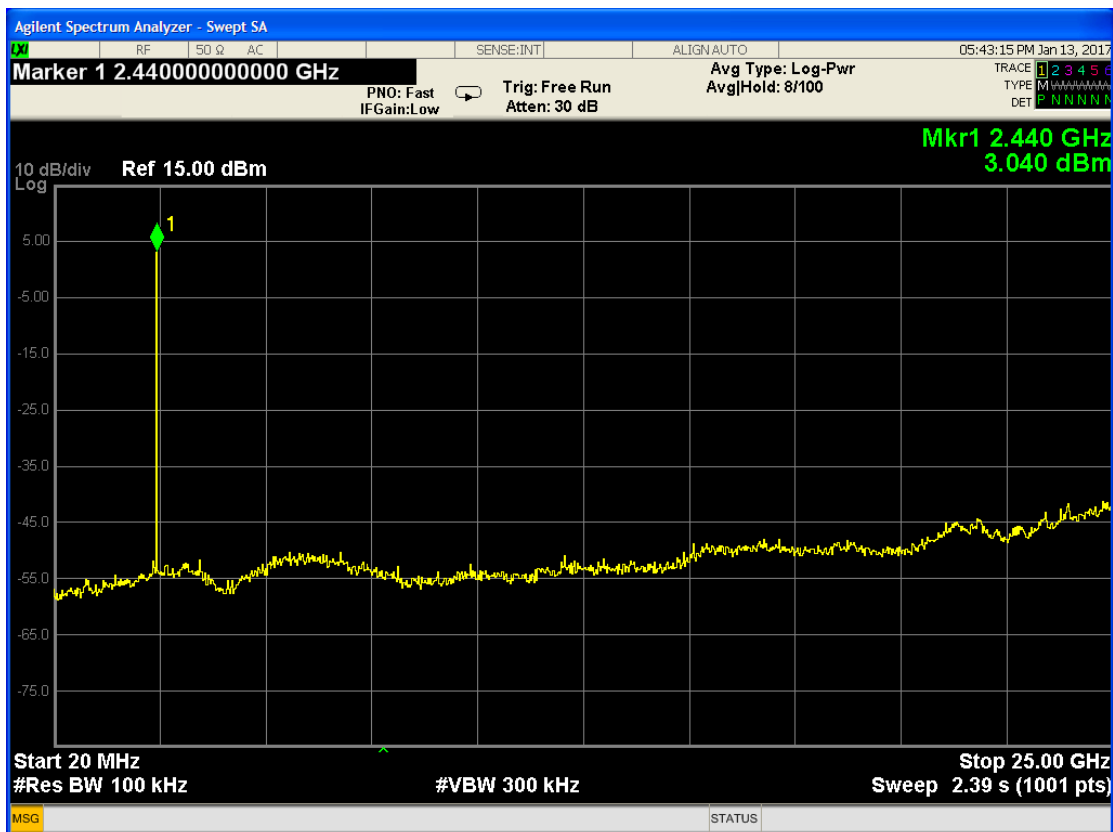

Channel 40: 2.480 GHz

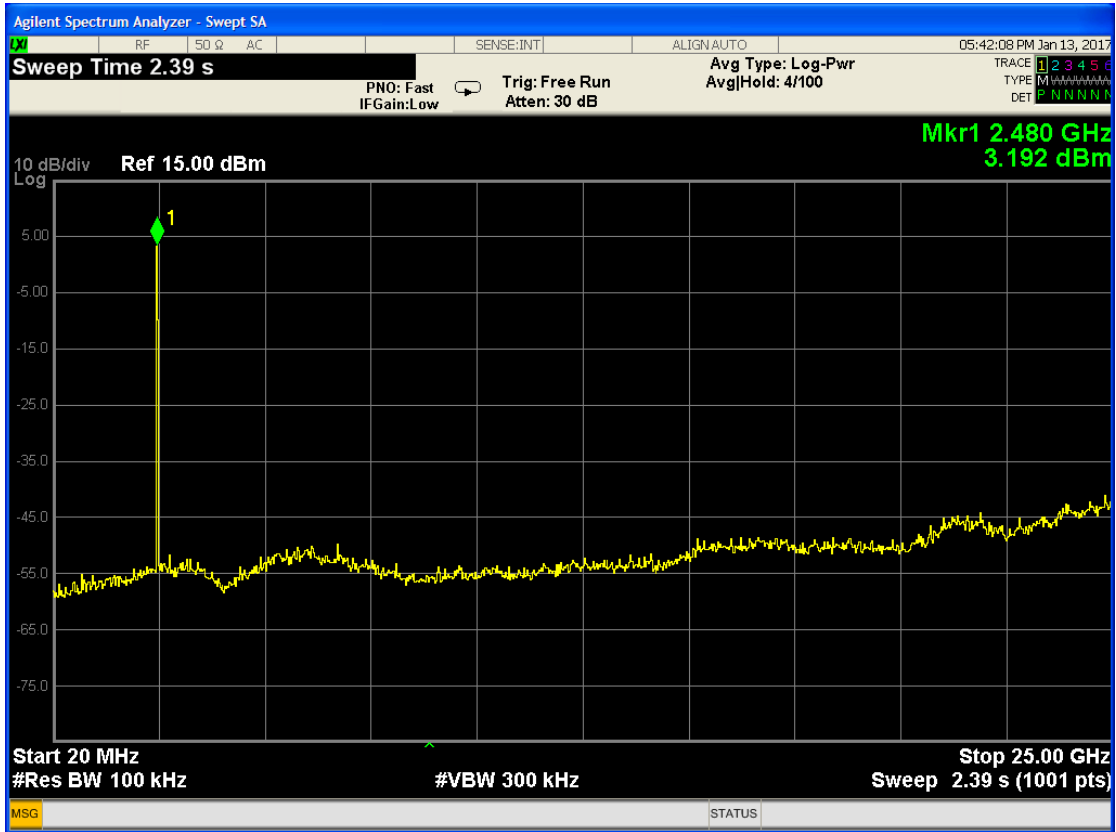

The results does meet the FCC requirements.

5.7 Radiated Spurious Emissions

Test Requirement: FCC Part 15 C section 15.247
(d) In any 100 kHz bandwidth outside the frequency band in which the spread spectrum or digitally modulated intentional radiator is operating. The radio frequency power that is produced by the intentional radiator shall be at least 20 dB below that in the 100 kHz bandwidth within the band that contains the highest level of the desired power, based on either an RF conducted or a radiated measurement, and provided the transmitter demonstrates compliance with the peak conducted power limits.

Test Method: ANSI C63.10:2013 Clause 6.4, 6.5 and 6.6

Test Status: Pre-Scan has been conducted to determine the worst-case mode from all possible combinations between available modulations, channels and antenna ports (if EUT with antenna diversity architecture). Following channel(s) was (were) selected for the final test as listed below.

Detector: For PK value:

RBW = 1 MHz for $f \geq 1$ GHz, 100 kHz for $f < 1$ GHz

VBW \geq RBW

Sweep = auto

Detector function = peak

Trace = max hold

For AV value:

RBW = 1 MHz for $f \geq 1$ GHz, 100 kHz for $f < 1$ GHz, 9kHz for < 30 MHz

VBW = 10 Hz

Sweep = auto

Detector function = peak

Trace = max hold

15.209 Limit: 40.0 dB μ V/m between 30 MHz & 88 MHz
43.5 dB μ V/m between 88 MHz & 216 MHz
46.0 dB μ V/m between 216 MHz & 960 MHz
54.0 dB μ V/m above 960 MHz

Test Configuration:

1) 9kHz to 30MHz emissions:

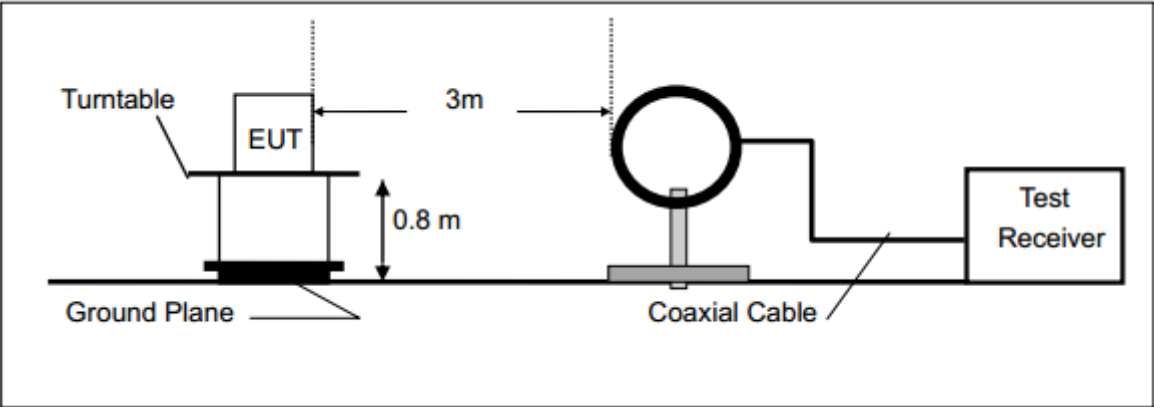

2) 30 MHz to 1 GHz emissions:

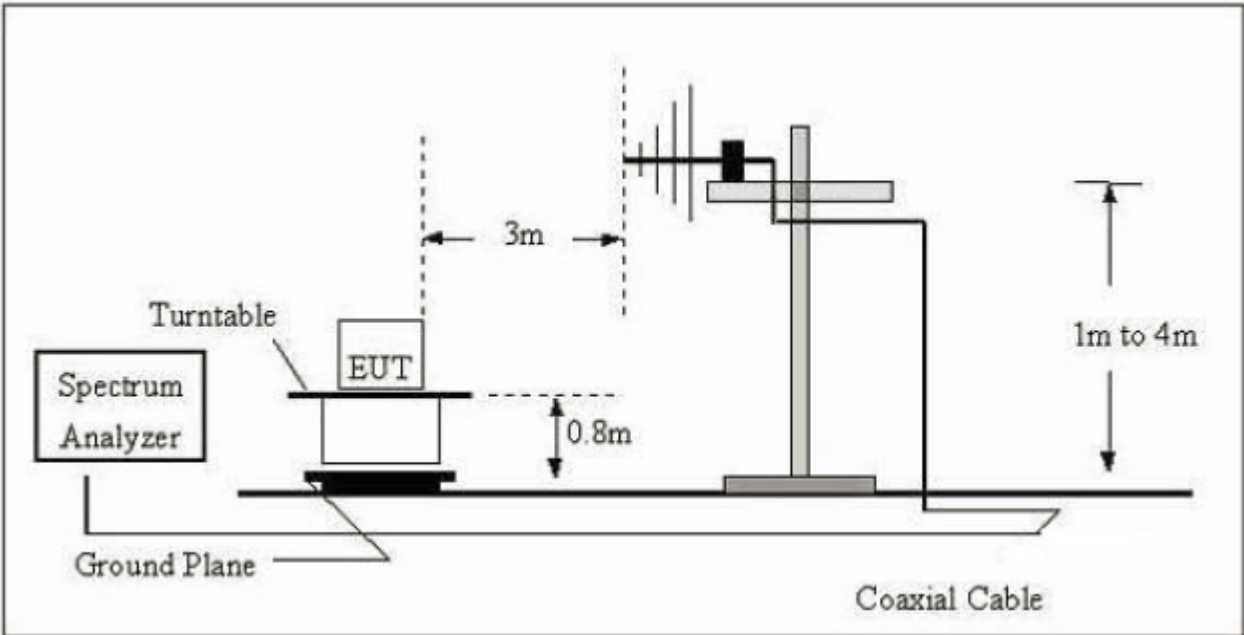

3) 1 GHz to 40 GHz emissions:

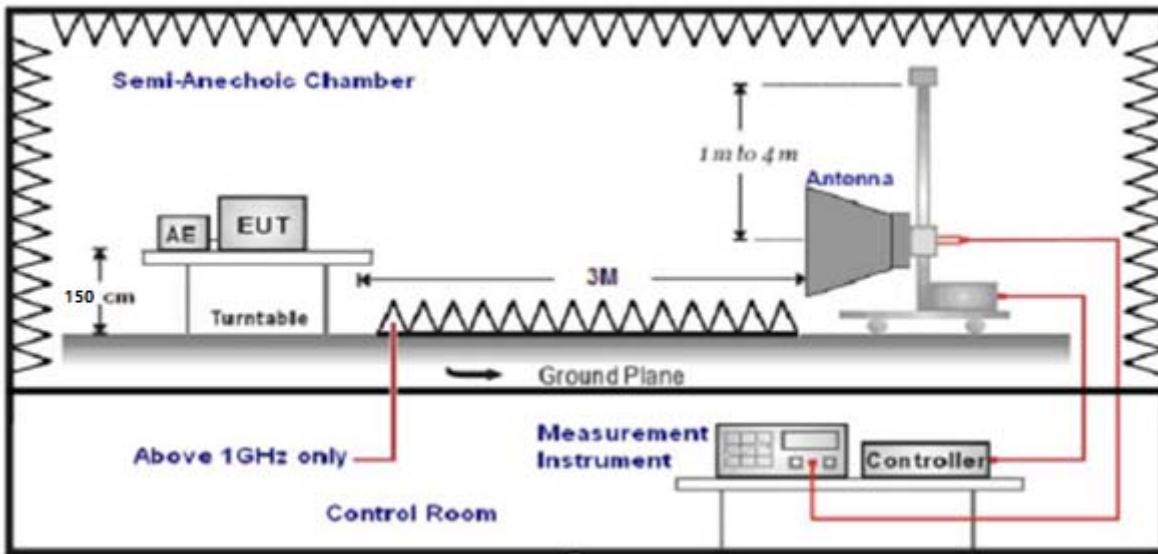

Test Procedure: The receiver was scanned from 9kHz to 25GHz. When an emission was found, the table was rotated to produce the maximum signal strength. An initial pre-scan was performed for in peak detection mode using the receiver. The EUT was measured for both the Horizontal and Vertical polarities and performed. For intentional radiators, measurements of the variation of the input power or the radiated signal level of the fundamental frequency component of the emission, as appropriate, shall be performed with the supply voltage varied between 85% and 115% of the nominal rated supply voltage. The worst case emissions were reported.

Now set the VBW to 10 Hz, while maintaining all of the other instrument settings. This peak level, once corrected, must comply with the limit specified in Section 15.209. If the dwell time per channel of the hopping signal is less than 100 ms, then the reading obtained with the 10 Hz VBW may be further adjusted by a "duty cycle correction factor", derived from $20\log(\text{dwell time}/100 \text{ ms})$, in an effort to demonstrate compliance with the 15.209 limit.

Submit this data.

For the radiated emission test above 1GHz:

Place the measurement antenna away from each area of the EUT determined to be a source of emissions at the specified measurement distance, while keeping the measurement antenna aimed at the source of emissions at each frequency of significant emissions, with polarization oriented for maximum response. The measurement antenna may have to be higher or lower than the EUT, depending on the radiation pattern of the emission and staying aimed at the emission source for receiving the maximum signal. The final measurement antenna elevation shall be that which maximizes the emissions. The measurement antenna elevation for maximum emissions shall be restricted to a range of heights of from 1 m to 4 m above the ground or reference ground plane.

5.7.1 Harmonic and other spurious emissions

Test at Channel 1 (2.402 GHz) in transmitting status

9kHz~30MHz Test result

The Low frequency, which started from 9kHz to 30MHz, was pre-scanned and the result which was 20dB lower than the limit line per 15.31(o) was not report

30 MHz~1 GHz Spurious Emissions .Quasi-Peak Measurement

Horizontal:

Peak scan

Level (dB μ V/m)

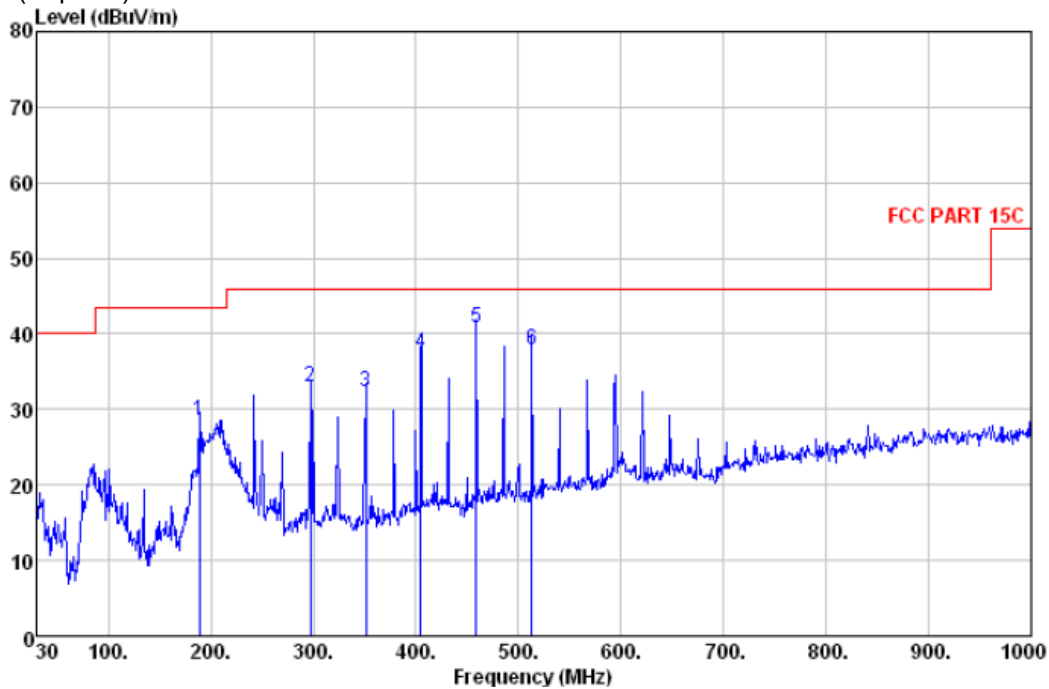

Quasi-peak measurement

No.	Freq MHz	Read Level dB μ V	Antenna Factor dB	Cable Loss dB	Preamp Factor dB	Level dB μ V/m	Limit Line dB μ V/m	Over Limit dB	Pol/Phase	Remark
1	189.080	45.78	8.73	1.66	27.62	28.55	43.50	-14.95	HORIZONTAL	QP
2	296.750	44.91	13.53	2.11	27.57	32.98	46.00	-13.02	HORIZONTAL	QP
3	351.070	43.70	13.75	2.28	27.35	32.38	46.00	-13.62	HORIZONTAL	QP
4	404.420	47.24	15.84	2.47	28.18	37.37	46.00	-8.63	HORIZONTAL	QP
5	458.740	49.80	16.95	2.65	28.53	40.87	46.00	-5.13	HORIZONTAL	QP
6	513.060	45.49	18.38	2.81	28.69	37.99	46.00	-8.01	HORIZONTAL	QP

Level=Read Level + Antenna Factor + Cable Loss - Preamp Factor

Vertical:

Peak scan

Level (dBµV/m)

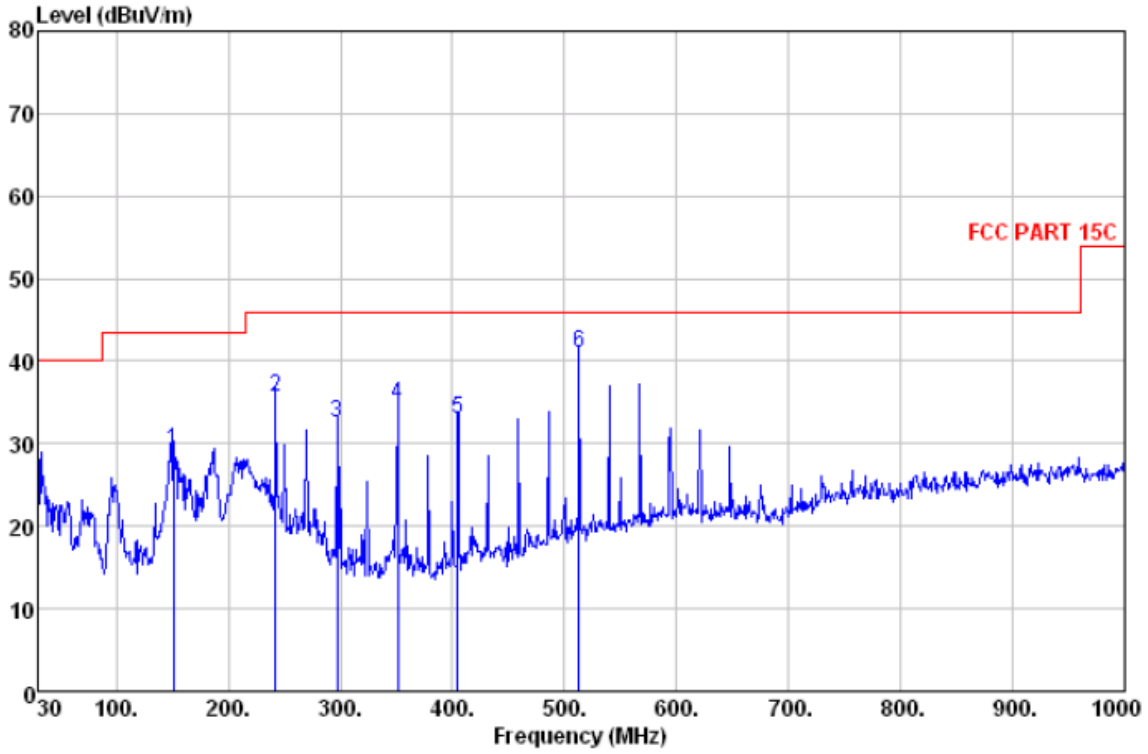

Quasi-peak measurement

No.	Freq MHz	Read Level dBµV	Antenna Factor dB	Cable Loss dB	Preamp Factor dB	Level dBµV/m	Limit Line dBµV/m	Over Limit dB	Pol/Phase	Remark
1	151.250	48.99	7.35	1.47	28.54	29.27	43.50	-14.23	VERTICAL	QP
2	242.430	50.24	10.84	1.90	27.22	35.76	46.00	-10.24	VERTICAL	QP
3	296.750	44.37	13.53	2.11	27.57	32.44	46.00	-13.56	VERTICAL	QP
4	351.070	46.09	13.75	2.28	27.35	34.77	46.00	-11.23	VERTICAL	QP
5	404.420	42.78	15.84	2.47	28.18	32.91	46.00	-13.09	VERTICAL	QP
6	513.060	48.46	18.38	2.81	28.69	40.96	46.00	-5.04	VERTICAL	QP

Level=Read Level + Antenna Factor + Cable Loss - Preamp Factor

1~25 GHz Harmonics & Spurious Emissions. Peak & Average Measurement

Peak Measurement:

Frequency (MHz)	Antenna factors (dB/m)	Cable loss (dB)	Preamp factor (dB)	Reading Level (dB μ V)	Emission Level (dB μ V/m)	Limit (dB μ V/m)	Antenna polarization
4804.000	34.32	9.59	27.62	35.41	51.70	74.00	V
7206.000	34.88	12.15	27.33	35.33	55.03	74.00	V
4804.000	34.32	9.59	27.62	33.51	49.80	74.00	H
7206.000	34.88	12.15	27.33	34.74	54.44	74.00	H

Average Measurement:

Frequency (MHz)	Antenna factors (dB/m)	Cable loss (dB)	Preamp factor (dB)	Reading Level (dB μ V)	Emission Level (dB μ V/m)	Limit (dB μ V/m)	Antenna polarization
4804.000	34.32	9.59	27.62	22.44	38.73	54.00	V
7206.000	34.88	12.15	27.33	23.23	42.93	54.00	V
4804.000	34.32	9.59	27.62	23.61	39.90	54.00	H
7206.000	34.88	12.15	27.33	22.23	41.93	54.00	H

Test at Channel 20 (2.440 GHz) in transmitting status

9 kHz~30MHz Test result

The Low frequency, which started from 9 kHz to 30MHz, was pre-scanned and the result which was 20dB lower than the limit line per 15.31(o) was not report

30 MHz~1 GHz Spurious Emissions .Quasi-Peak Measurement

Horizontal:

Peak scan

Level (dBμV/m)

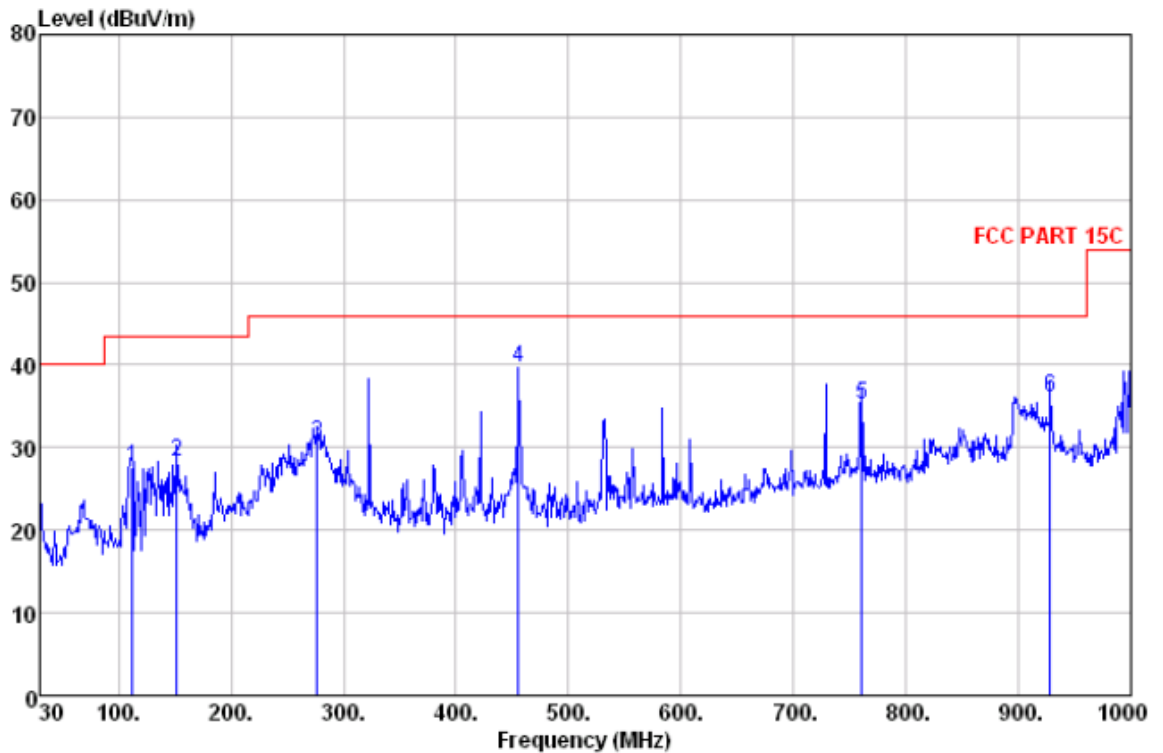

Quasi-peak measurement

No.	Freq MHz	Level dBμV/m	Remark	Antenna Factor dB/m	Cable Loss dB	Limit Line dBμV/m	Margin dB	A/pos cm	I/pos deg
1	112.450	27.56	QP	8.35	1.25	43.50	-15.94	100	223
2	152.220	28.25	QP	7.32	1.47	43.50	-15.25	100	172
3	276.380	30.48	QP	12.71	2.03	46.00	-15.52	100	286
4	455.830	39.75	QP	17.09	2.64	46.00	-6.25	200	212
5	760.410	35.17	QP	22.00	3.47	46.00	-10.83	200	176
6	928.220	36.02	QP	24.05	3.86	46.00	-9.98	200	321

Level=Read Level + Antenna Factor + Cable Loss

Vertical:

Peak scan

Level (dBµV/m)

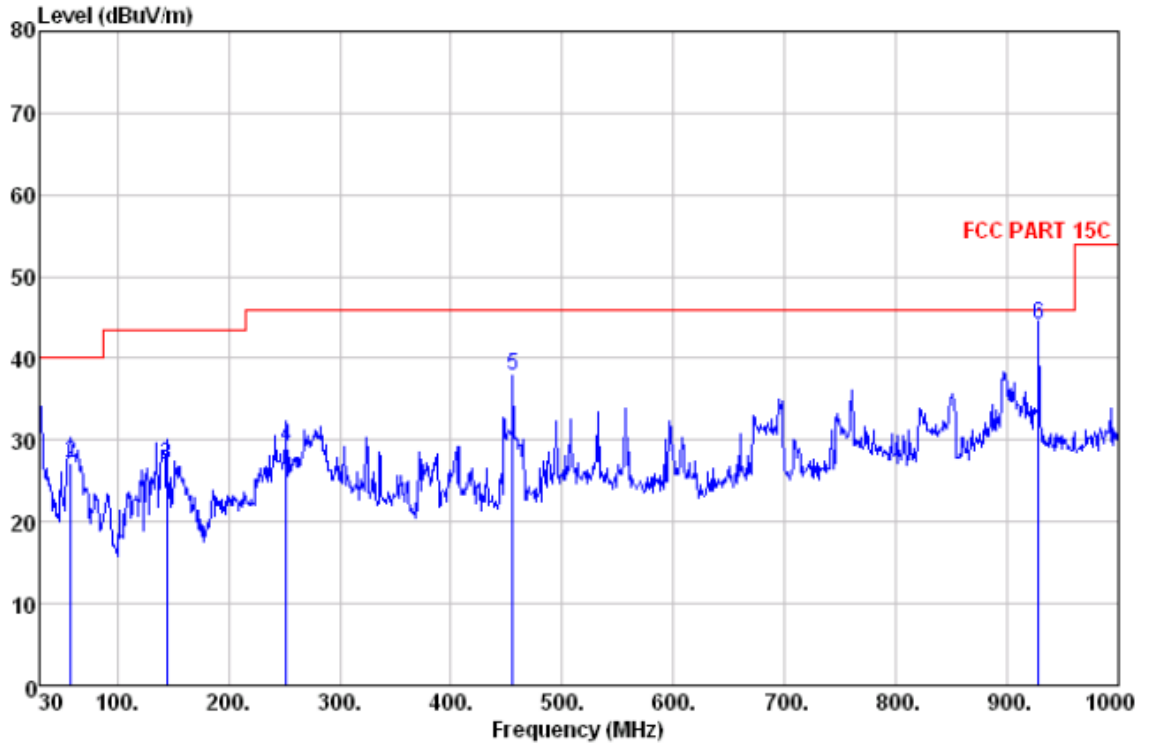

Quasi-peak measurement

No.	Freq MHz	Level dBµV/m	Remark	Antenna Factor dB/m	Cable Loss dB	Limit Line dBµV/m	Margin dB	A/pos cm	I/pos deg
1	30.000	33.71	QP	17.90	0.63	40.00	-6.29	100	233
2	58.130	27.25	QP	6.98	0.88	40.00	-12.75	100	27
3	144.460	27.06	QP	7.40	1.43	43.50	-16.44	100	227
4	252.130	29.28	QP	11.89	1.94	46.00	-16.72	200	223
5	455.830	37.89	QP	17.09	2.64	46.00	-8.11	200	212
6	928.220	44.04	QP	24.05	3.86	46.00	-1.96	200	133

Level=Read Level + Antenna Factor + Cable Loss

1~25 GHz Harmonics & Spurious Emissions. Peak & Average Measurement

Peak Measurement:

Frequency (MHz)	Antenna factors (dB/m)	Cable loss (dB)	Preamp factor (dB)	Reading Level (dB μ V)	Emission Level (dB μ V/m)	Limit (dB μ V/m)	Antenna polarization
4880.00	34.37	9.66	27.61	33.33	49.75	74.00	V
7320.00	35.07	12.23	27.33	33.46	53.43	74.00	V
4880.00	34.37	9.66	27.61	34.51	50.93	74.00	H
7320.00	35.07	12.23	27.33	35.25	55.22	74.00	H

Average Measurement:

Frequency (MHz)	Antenna factors (dB/m)	Cable loss (dB)	Preamp factor (dB)	Reading Level (dB μ V)	Emission Level (dB μ V/m)	Limit (dB μ V/m)	Antenna polarization
4880.00	34.37	9.66	27.61	23.42	39.84	54.00	V
7320.00	35.07	12.23	27.33	25.14	45.11	54.00	V
4880.00	34.37	9.66	27.61	24.66	41.08	54.00	H
7320.00	35.07	12.23	27.33	24.24	44.21	54.00	H

Test at Channel 40 (2.480 GHz) in transmitting status

9kHz~30MHz Test result

The Low frequency, which started from 9kHz to 30MHz, was pre-scanned and the result which was 20dB lower than the limit line per 15.31(o) was not report

30 MHz~1 GHz Spurious Emissions .Quasi-Peak Measurement

Horizontal:

Peak scan

Level (dBμV/m)

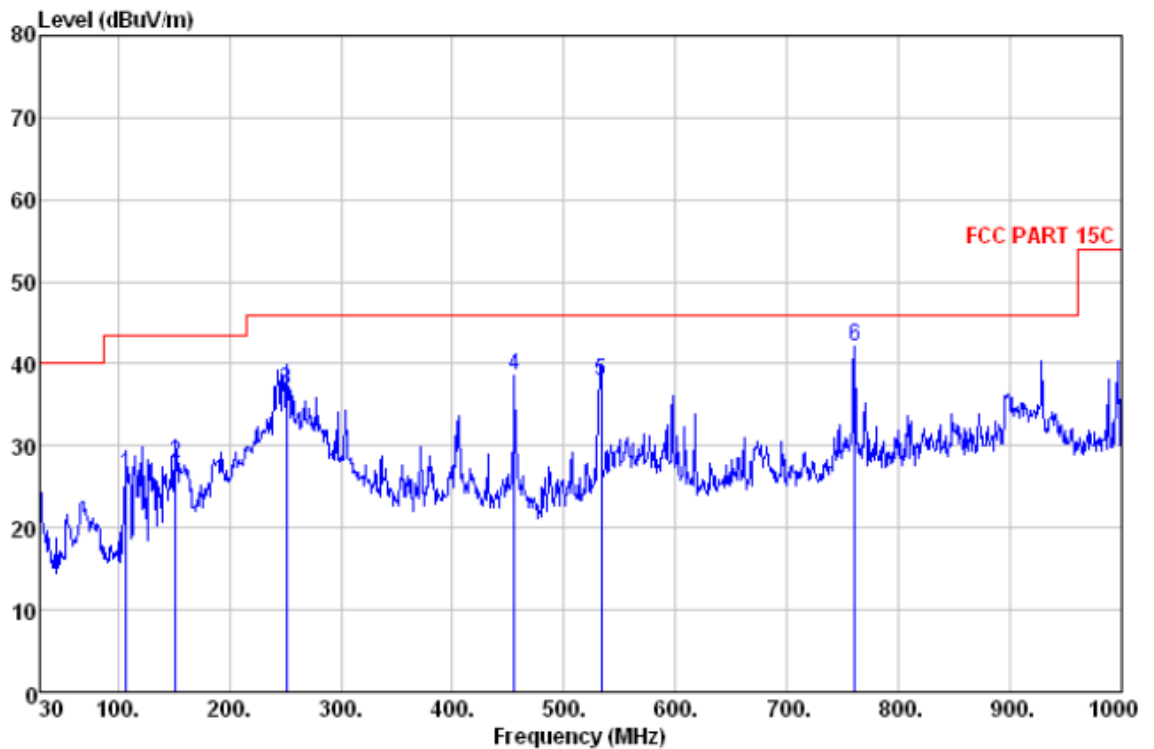

Quasi-peak measurement

No.	Freq MHz	Level dBμV/m	Remark	Antenna Factor dB/m	Cable Loss dB	Limit Line dBμV/m	Margin dB	A/pos cm	T/pos deg
1	107.600	26.43	QP	8.50	1.22	43.50	-17.07	100	186
2	152.220	27.79	QP	7.32	1.47	43.50	-15.71	100	245
3	251.160	36.82	QP	11.85	1.93	46.00	-9.18	100	241
4	455.830	38.65	QP	17.09	2.64	46.00	-7.35	200	332
5	533.430	37.98	QP	19.50	2.87	46.00	-8.02	200	147
6	760.410	42.06	QP	22.00	3.47	46.00	-3.94	200	286

Level=Read Level + Antenna Factor + Cable Loss

Vertical:

Peak scan

Level (dBµV/m)

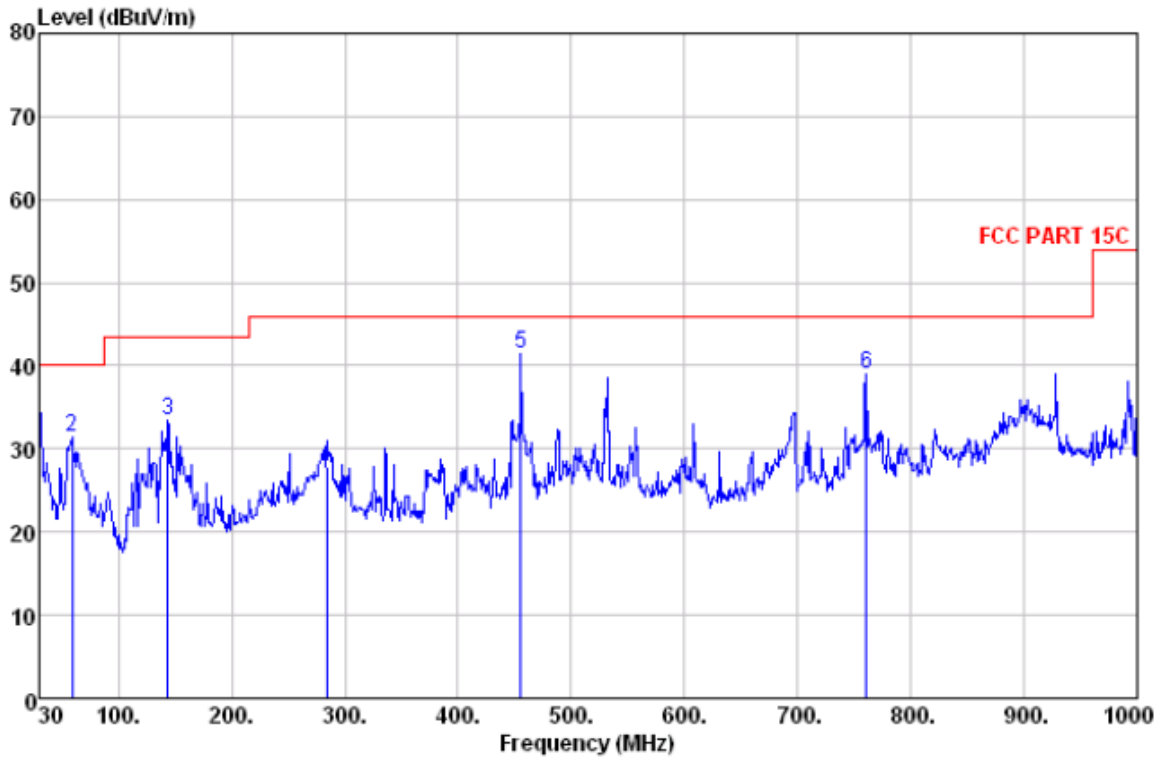

Quasi-peak measurement

No.	Freq MHz	Level dBµV/m	Remark	Antenna Factor dB/m	Cable Loss dB	Limit Line dBµV/m	Margin dB	A/pos cm	I/pos deg
1	30.000	35.74	QP	17.90	0.63	40.00	-4.26	100	253
2	59.100	31.32	QP	6.83	0.88	40.00	-8.68	100	188
3	143.490	33.46	QP	7.40	1.43	43.50	-10.04	100	175
4	284.140	27.96	QP	13.50	2.06	46.00	-18.04	200	245
5	455.830	41.41	QP	17.09	2.64	46.00	-4.59	200	111
6	760.410	38.92	QP	22.00	3.47	46.00	-7.08	200	23

Level=Read Level + Antenna Factor + Cable Loss

1~25 GHz Harmonics & Spurious Emissions. Peak & Average Measurement

Peak Measurement:

Frequency (MHz)	Antenna factors (dB/m)	Cable loss (dB)	Preamp factor (dB)	Reading Level (dBμV)	Emission Level (dBμV/m)	Limit (dBμV/m)	Antenna polarization
4960.00	34.36	9.60	27.61	35.22	51.57	74.00	V
7440.00	34.98	12.19	27.30	34.64	54.51	74.00	V
4960.00	34.36	9.60	27.61	34.23	50.58	74.00	H
7440.00	34.98	12.19	27.30	33.50	53.37	74.00	H

Average Measurement:

Frequency (MHz)	Antenna factors (dB/m)	Cable loss (dB)	Preamp factor (dB)	Reading Level (dBμV)	Emission Level (dBμV/m)	Limit (dBμV/m)	Antenna polarization
4960.00	34.36	9.60	27.61	23.34	39.69	54.00	V
7440.00	34.98	12.19	27.30	24.62	44.49	54.00	V
4960.00	34.36	9.60	27.61	23.33	39.68	54.00	H
7440.00	34.98	12.19	27.30	24.65	44.52	54.00	H

The field strength is calculated by adding the Antenna Factor. Cable Factor & Pre-amplifier. The basic equation with a sample calculation is as follows:

Final Test Level = Receiver Reading + Antenna Factor + Cable Factor – Pre-amplifier Factor.

No any other emissions level which are attenuated less than 20dB below the limit.

According to 15.31(o), the amplitude of spurious emissions from intentional radiators and emissions from unintentional radiators which are attenuated more than 20 dB below the permissible value need not be reported unless specifically required elsewhere in this Part.

Hence there no other emissions have been reported.

Remark:

- 1) .For this intentional radiator operates below 25 GHz. The spectrum shall be investigated to the tenth harmonics of the highest fundamental frequency. And above the third harmonic of this intentional radiator, the disturbance is very low. So the test result only displays to 3rd harmonic.
- 2). As shown in Section, for frequencies above 1000 MHz. the above field strength limits are based on average limits. However, the peak field strength of any emission shall not exceed the maximum permitted average limits specified above by more than 20 dB under any condition of modulation.
- 3). The test only perform the EUT in transmitting status since the test frequencies were over 1GHz only required transmitting status.

Test result: The unit does meet the FCC requirements.

5.8 Radiated Emissions which fall in the restricted bands

Test Requirement:	FCC Part 15 C section 15.247 (d) In addition, radiated emissions which fall in the restricted bands, as defined in Section 15.205(a), must also comply with the radiated emission limits specified in Section 15.209(a) (see Section 15.205(c)).
Test Method:	ANSI C63.10:2013 Clause 6.4, 6.5 and 6.6
Test Status:	Pre-Scan has been conducted to determine the worst-case mode from all possible combinations between available modulations, channels and antenna ports (if EUT with antenna diversity architecture). Following channel(s) was (were) selected for the final test as listed below.
Test site:	Measurement Distance: 3m (Semi-Anechoic Chamber)
Limit:	40.0 dB μ V/m between 30MHz & 88MHz; 43.5 dB μ V/m between 88MHz & 216MHz; 46.0 dB μ V/m between 216MHz & 960MHz; 54.0 dB μ V/m above 960MHz.
Detector:	For PK value: RBW = 1 MHz for $f \geq 1$ GHz, 100 kHz for $f < 1$ GHz VBW \geq RBW Sweep = auto Detector function = peak Trace = max hold For AV value: RBW = 1 MHz for $f \geq 1$ GHz, 100 kHz for $f < 1$ GHz VBW = 10Hz Sweep = auto Detector function = peak Trace = max hold

Section 15.205 Restricted bands of operation.

(a) Except as shown in paragraph (d) of this section. Only spurious emissions are permitted in any of the frequency bands listed below:

MHz	MHz	MHz	GHz
0.090 - 0.110	16.42 - 16.423	399.9 - 410	4.5 - 5.15
¹ 0.495 - 0.505	16.69475 - 16.69525	608 - 614	5.35 - 5.46
2.1735 - 2.1905	16.80425 - 16.80475	960 - 1240	7.25 - 7.75
4.125 - 4.128	25.5 - 25.67	1300 - 1427	8.025 - 8.5
4.17725 - 4.17775	37.5 - 38.25	1435 - 1626.5	9.0 - 9.2
4.20725 - 4.20775	73 - 74.6	1645.5 - 1646.5	9.3 - 9.5
6.215 - 6.218	74.8 - 75.2	1660 - 1710	10.6 - 12.7
6.26775 - 6.26825	108 - 121.94	1718.8 - 1722.2	13.25 - 13.4
6.31175 - 6.31225	123 - 138	2200 - 2300	14.47 - 14.5
8.291 - 8.294	149.9 - 150.05	2310 - 2390	15.35 - 16.2
8.362 - 8.366	156.52475 -	2483.5 - 2500	17.7 - 21.4
8.37625 - 8.38675	156.52525	2655 - 2900	22.01 - 23.12
8.41425 - 8.41475	156.7 - 156.9	3260 - 3267	23.6 - 24.0
12.29 - 12.293	162.0125 - 167.17	3332 - 3339	31.2 - 31.8
12.51975 - 12.52025	167.72 - 173.2	3345.8 - 3358	36.43 - 36.5
12.57675 - 12.57725	240 - 285	3600 - 4400	
13.36 - 13.41	322 - 335.4		

Test Result:

Test at Channel 1 (2.402 GHz) in transmitting status

Antenna polarization: Vertical

Frequency (MHz)	Antenna factors (dB/m)	Cable loss(dB)	Preamp factor(dB)	Peak Reading Level (dB μ V)	Average Reading Level (dB μ V)	Peak Emission Level (dB μ V/m)	Average Emission Level (dB μ V/m)
2310.000	26.65	6.45	27.78	34.22	22.43	39.54	27.75
2390.000	26.56	6.46	27.79	33.52	24.22	38.75	29.45
2500.000	25.70	6.62	27.80	34.15	23.65	38.67	28.17
2483.500	25.79	6.61	27.80	35.45	22.76	40.05	27.36

Antenna polarization: Horizontal

Frequency (MHz)	Antenna factors (dB/m)	Cable loss(dB)	Preamp factor(dB)	Peak Reading Level (dB μ V)	Average Reading Level (dB μ V)	Peak Emission Level (dB μ V/m)	Average Emission Level (dB μ V/m)
2310.000	26.65	6.45	27.78	34.66	22.75	39.98	28.07
2390.000	26.56	6.46	27.79	34.63	24.63	39.86	29.86
2500.000	25.70	6.62	27.80	37.41	22.61	41.93	27.13
2483.500	25.79	6.61	27.80	36.88	23.32	41.48	27.92

Test at Channel 20 (2.440 GHz) in transmitting status

Antenna polarization: Vertical

Frequency (MHz)	Antenna factors (dB/m)	Cable loss(dB)	Preamp factor(dB)	Peak Reading Level (dB μ V)	Average Reading Level (dB μ V)	Peak Emission Level (dB μ V/m)	Average Emission Level (dB μ V/m)
2310.000	26.65	6.45	27.78	38.32	22.61	43.64	27.93
2390.000	26.56	6.46	27.79	37.22	24.18	42.45	29.41
2500.000	25.70	6.62	27.80	36.87	23.07	41.39	27.59
2483.500	25.79	6.61	27.80	36.42	22.33	41.02	26.93

Antenna polarization: Horizontal

Frequency (MHz)	Antenna factors (dB/m)	Cable loss(dB)	Preamp factor(dB)	Peak Reading Level (dB μ V)	Average Reading Level (dB μ V)	Peak Emission Level (dB μ V/m)	Average Emission Level (dB μ V/m)
2310.000	26.65	6.45	27.78	36.56	23.45	41.88	28.77
2390.000	26.56	6.46	27.79	35.34	22.32	40.57	27.55
2500.000	25.70	6.62	27.80	35.55	23.42	40.07	27.94
2483.500	25.79	6.61	27.80	34.64	22.55	39.24	27.15

Test at Channel 40 (2.480 GHz) in transmitting status

Antenna polarization: Vertical

Frequency (MHz)	Antenna factors (dB/m)	Cable loss(dB)	Preamp factor(dB)	Peak Reading Level (dB μ V)	Average Reading Level (dB μ V)	Peak Emission Level (dB μ V/m)	Average Emission Level (dB μ V/m)
2310.000	26.65	6.45	27.78	32.64	23.32	37.96	28.64
2390.000	26.56	6.46	27.79	33.06	22.75	38.29	27.98
2500.000	25.70	6.62	27.80	35.44	22.18	39.96	26.70
2483.500	25.79	6.61	27.80	35.32	23.13	39.92	27.73

Antenna polarization: Horizontal

Frequency (MHz)	Antenna factors (dB/m)	Cable loss(dB)	Preamp factor(dB)	Peak Reading Level (dB μ V)	Average Reading Level (dB μ V)	Peak Emission Level (dB μ V/m)	Average Emission Level (dB μ V/m)
2310.000	26.65	6.45	27.78	33.62	23.76	38.94	29.08
2390.000	26.56	6.46	27.79	33.88	22.66	39.11	27.89
2500.000	25.70	6.62	27.80	35.35	24.07	39.87	28.59
2483.500	25.79	6.61	27.80	35.54	22.55	40.14	27.15

5.9 Band Edges Requirement

Test Requirement: FCC Part 15 C section 15.247
(d) In any 100 kHz bandwidth outside the frequency band in which the spread spectrum or digitally modulated intentional radiator is operating. The radio frequency power that is produced by the intentional radiator shall be at least 20 dB below that in the 100 kHz bandwidth within the band that contains the highest level of the desired power. Based on either an RF conducted or a radiated measurement. Provided the transmitter demonstrates compliance with the peak conducted power limits.

Frequency Band: 2400 MHz to 2483.5 MHz

Test Method: ANSI C63.10:2013 Clause 6.9

Test Status: Pre-Scan has been conducted to determine the worst-case mode from all possible combinations between available modulations, channels and antenna ports (if EUT with antenna diversity architecture). Following channel(s) was (were) selected for the final test as listed below.

Test Configuration:

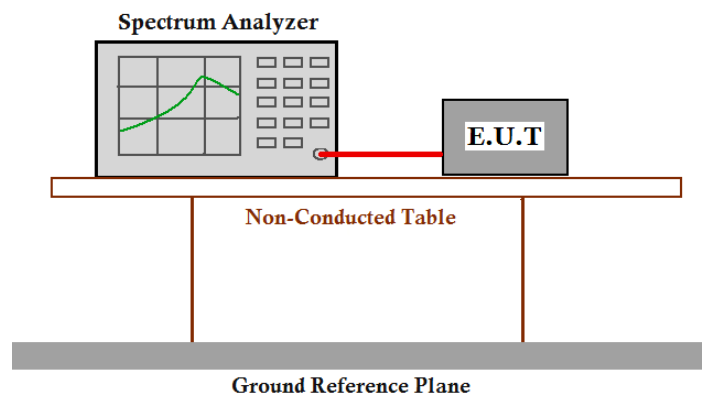

Test Procedure:

1. Remove the antenna from the EUT and then connect a low RF cable from the antenna port to the spectrum analyzer or power meter.
2. Set RBW=100 kHz, VBW=300 KHz, suitable frequency span including 1000 kHz bandwidth from band edge.
3. Measure the Conducted Spurious Emissions and Radiated Emissions of the test frequency with special test status.
4. Repeat until all the test status is investigated.
5. Report the worse.

5.10 Conducted Emissions at Mains Terminals 150 kHz to 30MHz

Test Requirement: FCC Part 15 C section 15.207

Test Method: ANSI C63.10:2013 Clause 6.2

Test Voltage: 120V AC, 60Hz

Frequency Range: 150 kHz to 30 MHz

Detector: Peak for pre-scan (9 kHz Resolution Bandwidth)

Test Limit

Limits for conducted disturbance at the mains ports of class B

Frequency Range	Class B Limit dB(μ V)	
	Quasi-peak	Average
0.15 to 0.50	66 to 56	56 to 46
0.50 to 5	56	46
5 to 30	60	50

NOTE 1 The limit decreases linearly with the logarithm of the frequency in the range 0,15 MHz to 0,50 MHz.

EUT Operation:

Test in normal operating mode. For intentional radiators, measurements of the variation of the input power or the radiated signal level of the fundamental frequency component of the emission, as appropriate, shall be performed with the supply voltage varied between 85% and 115% of the nominal rated supply voltage.

Pre-Scan has been conducted to determine the worst-case mode from all possible combinations between available modulations, channels and antenna ports (if EUT with antenna diversity architecture).

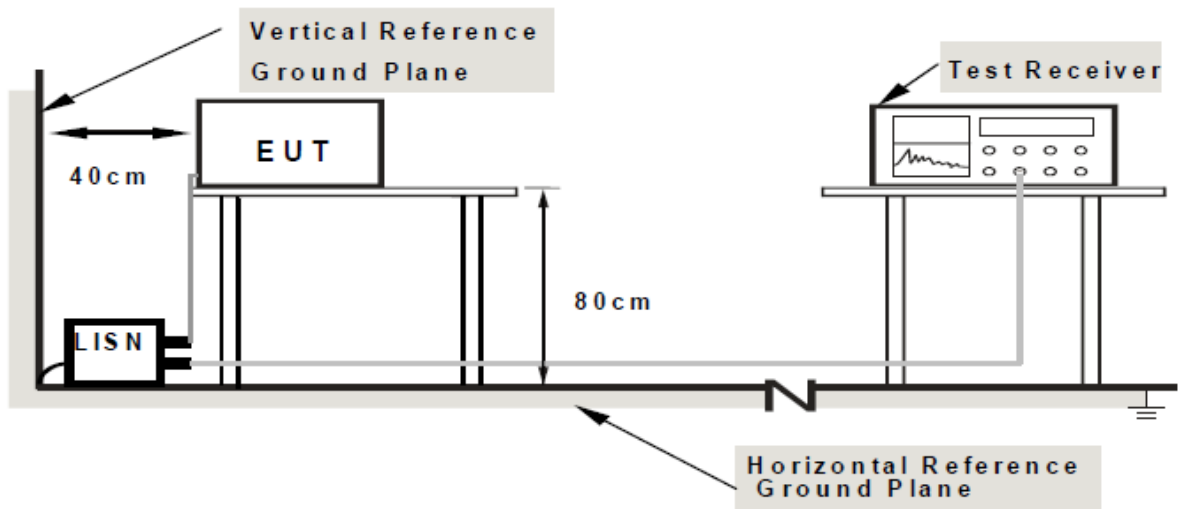
Test Configuration:

Note: 1. Support units were connected to second LISN.

2. Both of LISNs (AMN) are 80 cm from EUT and at least 80 cm from other units and other metal planes

Test procedure:

1. The mains terminal disturbance voltage test was conducted in a shielded room.
2. The tabletop EUT was placed upon a non-metallic table 0.8m above the ground reference plane. And for floor-standing arrangement, the EUT was placed on the horizontal ground reference plane, but separated from metallic contact with the ground reference plane by 0.1m of insulation.

5.10.1 Measurement Data

An initial pre-scan was performed on the live and neutral lines with peak detector.

Quasi-Peak and Average measurement were performed at the frequencies with maximized peak emission were detected. For EUT the communicating was worst case mode.

The following Quasi-Peak and Average measurements were performed on the EUT Live line

Peak Scan:

Level (dBμV)

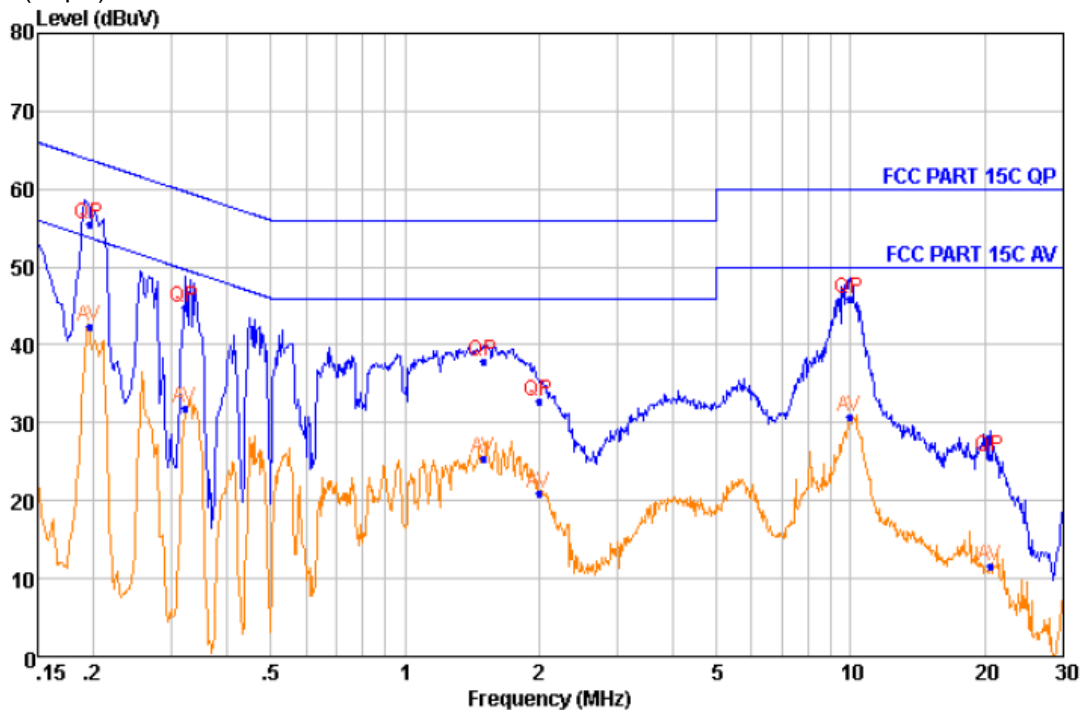

Quasi-peak and Average measurement

NO.	Freq MHz	Level dBμV	Remark	LISN Factor dB	Cable Loss dB	Limit Line dBμV	Over Limit dB
1	0.195	55.44	QP	9.53	0.40	63.80	-8.36
2	0.195	42.44	Average	9.53	0.40	53.80	-11.36
3	0.321	44.74	QP	9.44	0.42	59.68	-14.94
4	0.321	31.81	Average	9.44	0.42	49.68	-17.87
5	1.500	37.99	QP	9.30	0.48	56.00	-18.01
6	1.500	25.45	Average	9.30	0.48	46.00	-20.55
7	2.000	32.81	QP	9.32	0.49	56.00	-23.19
8	2.000	20.97	Average	9.32	0.49	46.00	-25.03
9	9.946	45.96	QP	9.37	0.56	60.00	-14.04
10	9.946	30.65	Average	9.37	0.56	50.00	-19.35
11	20.547	25.64	QP	9.75	0.59	60.00	-34.36
12	20.547	11.49	Average	9.75	0.59	50.00	-38.51

Neutral Line

Peak Scan:

Level (dBµV)

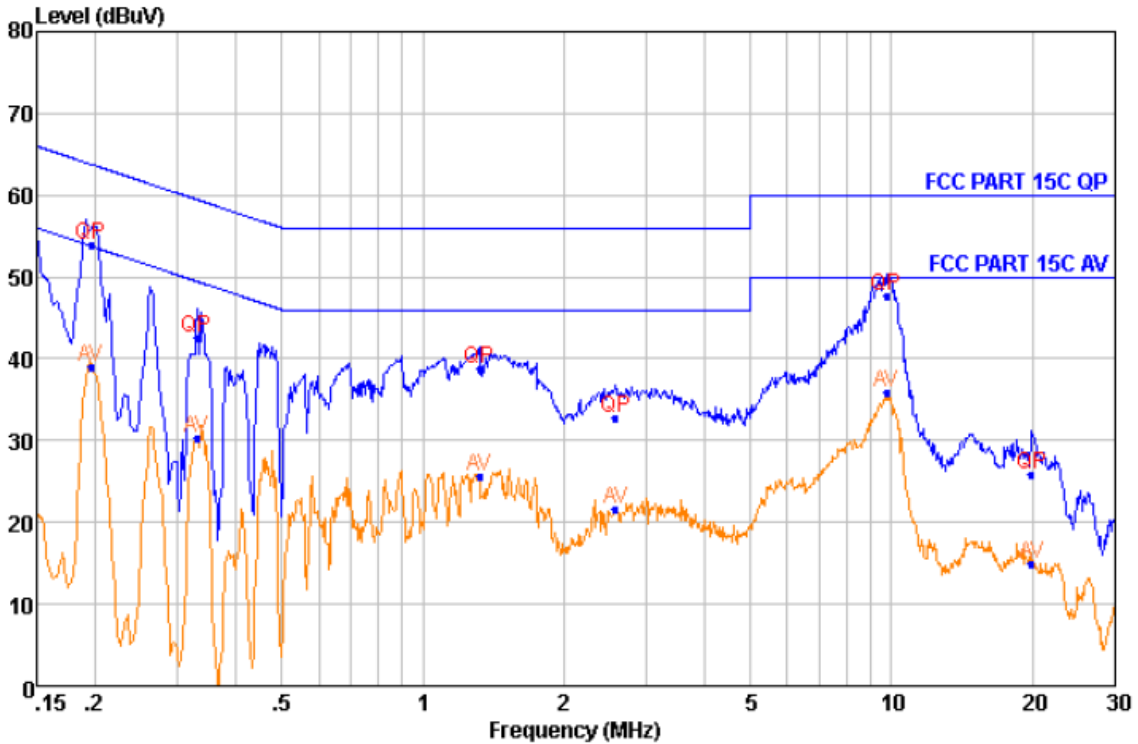

Quasi-peak and Average measurement

NO.	Freq MHz	Level dBµV	Remark	LISN Factor dB	Cable Loss dB	Limit Line dBµV	Over Limit dB
1	0.195	54.03	QP	9.37	0.40	63.80	-9.77
2	0.195	39.03	Average	9.37	0.40	53.80	-14.77
3	0.330	42.58	QP	9.36	0.42	59.46	-16.88
4	0.330	30.36	Average	9.36	0.42	49.46	-19.10
5	1.321	38.67	QP	9.38	0.48	56.00	-17.33
6	1.321	25.68	Average	9.38	0.48	46.00	-20.32
7	2.575	32.80	QP	9.40	0.50	56.00	-23.20
8	2.575	21.59	Average	9.40	0.50	46.00	-24.41
9	9.741	47.59	QP	9.54	0.56	60.00	-12.41
10	9.741	35.95	Average	9.54	0.56	50.00	-14.05
11	19.903	25.87	QP	9.91	0.58	60.00	-34.13
12	19.903	14.86	Average	9.91	0.58	50.00	-35.14

-- End of test report --