



TEST REPORT

Report Reference No...... : **TRE1410009401** R/C.....:53771
FCC ID..... : **2AAP6M7054**
Applicant's name..... : **SHENZHEN ZOWEE TECHNOLOGY CO.,LTD**
 Address..... : Science &Technology Industrial Park of Privately Owned Enterprises, Pingshan, Xili, Nanshan District, Shenzhen, PR CHINA
 Manufacturer..... : SHENZHEN ZOWEE TECHNOLOGY CO.,LTD
 Address..... : Science &Technology Industrial Park of Privately Owned Enterprises, Pingshan, Xili, Nanshan District, Shenzhen, PR CHINA
Test item description : **Internet Tablet**
 Trade Mark : TMAX,APEX,DOPO,NOBIS,DAGE, NOVISION
 Model/Type reference..... : M7054
 Listed Model(s) : DPM7828,DPM7827,DPM7826, TM7005, TM7006, TM7008, NB7856, NB7866
Standard : **FCC CFR Title 47 Part 15 Subpart C Section 15.247**
 Date of receipt of test sample..... : Oct 24, 2014
 Date of testing..... : Oct 25 ~ Nov 04, 2014
 Date of issue..... : Nov 04, 2014
Result..... : **PASS**

Compiled by
 (position+printed name+signature)...: File administrators Any Yang

Any Yang

Supervised by
 (position+printed name+signature)...: Project Engineer Lion Cai

Lion Cai

Approved by
 (position+printed name+signature)...: RF Manager Hans Hu

Hans Hu

Testing Laboratory Name : **Shenzhen Huatongwei International Inspection Co., Ltd**
 Address..... : Bldg3, Hongfa Hi-tech Industrial Park, Genyu Road, Shenzhen, China

Shenzhen Huatongwei International Inspection Co., Ltd. All rights reserved.

This publication may be reproduced in whole or in part for non-commercial purposes as long as the Shenzhen Huatongwei International Inspection Co., Ltd is acknowledged as copyright owner and source of the material. Shenzhen Huatongwei International Inspection Co., Ltd takes no responsibility for and will not assume liability for damages resulting from the reader's interpretation of the reproduced material due to its placement and context.

Contents

| | | |
|-----------|---|-----------|
| 1. | <u>TEST STANDARDS AND TEST DESCRIPTION</u> | 3 |
| 1.1. | Test Standards | 3 |
| 1.2. | Test Description | 3 |
| 2. | <u>SUMMARY</u> | 4 |
| 2.1. | Client Information | 4 |
| 2.2. | Product Description | 4 |
| 2.3. | EUT operation mode | 5 |
| 2.4. | EUT configuration | 5 |
| 2.5. | Modifications | 5 |
| 3. | <u>TEST ENVIRONMENT</u> | 6 |
| 3.1. | Address of the test laboratory | 6 |
| 3.2. | Test Facility | 6 |
| 3.3. | Environmental conditions | 7 |
| 3.4. | Statement of the measurement uncertainty | 7 |
| 3.5. | Equipments Used during the Test | 8 |
| 4. | <u>TEST CONDITIONS AND RESULTS</u> | 9 |
| 4.1. | Antenna requirement | 9 |
| 4.2. | Conducted Emission (AC Main) | 10 |
| 4.3. | Conducted Peak Output Power | 13 |
| 4.4. | Power Spectral Density | 14 |
| 4.5. | 6dB bandwidth | 19 |
| 4.6. | Band Edge | 24 |
| 4.7. | Spurious Emission (conducted) | 33 |
| 4.8. | Spurious Emission (radiated) | 46 |
| 5. | <u>TEST SETUP PHOTOS OF THE EUT</u> | 53 |
| 6. | <u>EXTERNAL AND INTERNAL PHOTOS OF THE EUT</u> | 54 |

1. TEST STANDARDS AND TEST DESCRIPTION

1.1. Test Standards

The tests were performed according to following standards:

[FCC Rules Part 15.247](#): Frequency Hopping, Direct Spread Spectrum and Hybrid Systems that are in operation within the bands of 902-928 MHz, 2400-2483.5 MHz, and 5725-5850 MHz.

[ANSI C63.10](#): American National Standard for Testing Unlicensed Wireless Devices

[KDB558074 D01 V03R02](#): Guidance for Performing Compliance Measurements on Digital Transmission Systems (DTS) Operating Under §15.247

1.2. Test Description

| Test Item | Section in CFR 47 | Result |
|-----------------------------------|-------------------|--------|
| Antenna requirement | 15.203/15.247 (c) | Pass |
| Line Conducted Emission (AC Main) | 15.207 | Pass |
| Conducted Peak Output Power | 15.247 (b)(3) | Pass |
| Power Spectral Density | 15.247 (e) | Pass |
| 6dB Bandwidth | 15.247 (a)(2) | Pass |
| Band Edge | 15.247(d) | Pass |
| Spurious Emission | 15.205/15.209 | Pass |

Remark: The measurement uncertainty is not included in the test result.

2. SUMMARY

2.1. Client Information

| | |
|---------------|---|
| Applicant: | SHENZHEN ZOWEE TECHNOLOGY CO.,LTD |
| Address: | Science &Technology Industrial Park of Privately Owned Enterprises, Pingshan, Xili, Nanshan District, Shenzhen, PR CHINA |
| Manufacturer: | SHENZHEN ZOWEE TECHNOLOGY CO.,LTD |
| Address: | Science &Technology Industrial Park of Privately Owned Enterprises, Pingshan, Xili, Nanshan District, Shenzhen, PR CHINA |

2.2. Product Description

| | |
|----------------------|---|
| Name of EUT | Internet Tablet |
| Trade Mark: | TMAX,APEX,DOPO,NOBIS,DAGE, NOVISION |
| Model No.: | M7054 |
| Listed Model(s): | DPM7828,DPM7827,DPM7826, TM7005, TM7006, TM7008, NB7856, NB7866 |
| Power supply: | DC 3.7V From Internal Battery |
| Adapter information: | Model No.:JK050150-S02USU Input: AC 100-240V~, 50/60Hz, 0.3A Output: DC 5.0V 1.5A |
| WIFI | |
| Supported type: | 802.11b/802.11g/802.11n(H20)/802.11n(H40) |
| Modulation: | 802.11b: DSSS 802.11g/802.11n(H20)/802.11n(H40):OFDM |
| Operation frequency: | 802.11b/802.11g/802.11n(H20): 2412MHz~2462MHz 802.11n(H40): 2422MHz~2452MHz |
| Channel number: | 802.11b/802.11g/802.11n(H20): 11 802.11n(H40): 7 |
| Channel separation: | 5MHz |
| Antenna type: | Internal Antenna |
| Antenna gain: | 2.0 dBi |

Operation Frequency List:

| 802.11b/g/n(H20) | | 802.11n(H40) | |
|------------------|-----------------|--------------|-----------------|
| Channel | Frequency (MHz) | Channel | Frequency (MHz) |
| 01 | 2412 | 01 | -- |
| 02 | 2417 | 02 | -- |
| 03 | 2422 | 03 | 2422 |
| ⋮ | ⋮ | ⋮ | ⋮ |
| 06 | 2437 | 06 | 2442 |
| ⋮ | ⋮ | ⋮ | ⋮ |
| 09 | 2452 | 09 | 2452 |
| 10 | 2457 | 10 | -- |
| 11 | 2462 | 11 | -- |

Note:

In section 15.31(m), regards to the operating frequency range over 10 MHz, the Lowest frequency, the middle frequency, and the highest frequency of channel were selected to perform the test, please see the above gray bottom.

2.3. EUT operation mode

The EUT has been tested under test mode condition. The Applicant provides software to control the EUT for staying in continuous transmitting and receiving mode for testing.

And found which the below bit rate is worst case mode, so only show data which it is a worst case mode.

| Mode | Bit rate (worst mode) |
|--------------|-----------------------|
| 802.11b | 1Mbps |
| 802.11g | 6Mbps |
| 802.11n(H20) | 6.5Mbps |
| 802.11n(H40) | 6.5Mbps |

The EUT was programmed to be in continuously transmitting mode and the transmit duty cycle is not less than 98%.

2.4. EUT configuration

The following peripheral devices and interface cables were connected during the measurement:

● - supplied by the manufacturer

○ - supplied by the lab

| | | | |
|-----------------------|-------------|----------------|---|
| <input type="radio"/> | Power Cable | Length (m) : | / |
| | | Shield : | / |
| | | Detachable : | / |
| <input type="radio"/> | Multimeter | Manufacturer : | / |
| | | Model No. : | / |

2.5. Modifications

No modifications were implemented to meet testing criteria.

3. TEST ENVIRONMENT

3.1. Address of the test laboratory

Test Laboratory: Shenzhen Huatongwei International Inspection Co., Ltd
Address: Bldg3, Hongfa Hi-tech Industrial Park, Genyu Road, Shenzhen, China
Phone: 86-755-26715686 Fax: 86-755-26748089

3.2. Test Facility

The test facility is recognized, certified, or accredited by the following organizations:

CNAS-Lab Code: L1225

Shenzhen Huatongwei International Inspection Co., Ltd. has been assessed and proved to be in compliance with CNAS-CL01 Accreditation Criteria for Testing and Calibration Laboratories (identical to ISO/IEC 17025: 2005 General Requirements) for the Competence of Testing and Calibration Laboratories, Date of Registration: Mar. 01, 2012. Valid time is until February 28, 2015.

A2LA-Lab Cert. No. 2243.01

Shenzhen Huatongwei International Inspection Co., Ltd. EMC Laboratory has been accredited by A2LA for technical competence in the field of electrical testing, and proved to be in compliance with ISO/IEC 17025: 2005 General Requirements for the Competence of Testing and Calibration Laboratories and any additional program requirements in the identified field of testing. Valid time is until Sept 30, 2015.

FCC-Registration No.: 662850

Shenzhen Huatongwei International Inspection Co., Ltd. EMC Laboratory has been registered and fully described in a report filed with the FCC (Federal Communications Commission). The acceptance letter from the FCC is maintained in our files. Registration 662850, Renewal date Jul. 01, 2012, valid time is until Jun. 01, 2015.

FCC-Registration No.: 317478

Shenzhen Huatongwei International Inspection Co., Ltd. (Gongming EMC Laboratory) has been registered and fully described in a report filed with the FCC (Federal Communications Commission). The acceptance letter from the FCC is maintained in our files. Registration 317478, Renewal date July 18, 2014, valid time is until July. 18, 2017.

IC-Registration No.: 5377A

The 3m Alternate Test Site of Shenzhen Huatongwei International Inspection Co., Ltd. has been registered by Certification and Engineering Bureau of Industry Canada for the performance of radiated measurements with Registration No. 5377A on Dec. 31, 2013, valid time is until Dec. 31, 2016.

IC-Registration No.: 5377B

The 3m Alternate Test Site of Shenzhen Huatongwei International Inspection Co., Ltd. (Gongming EMC Laboratory) has been registered by Certification and Engineering Bureau of Industry Canada for the performance of radiated measurements with Registration No. 5377B on September 3, 2014, valid time is until September 3, 2017.

ACA

Shenzhen Huatongwei International Inspection Co., Ltd. EMC Laboratory can also perform testing for the Australian C-Tick mark as a result of our A2LA accreditation.

VCCI

The 3m Semi-anechoic chamber (12.2m×7.95m×6.7m) of Shenzhen Huatongwei International Inspection Co., Ltd. has been registered in accordance with the Regulations for Voluntary Control Measures with Registration No.:R-2484. Date of Registration: Dec. 20, 2012. Valid time is until Dec. 29, 2015.

Radiated disturbance above 1GHz measurement of Shenzhen Huatongwei International Inspection Co., Ltd. has been registered in accordance with the Regulations for Voluntary Control Measures with Registration No.: G-292. Date of Registration: Dec. 24, 2013. Valid time is until Dec. 23, 2016.

Main Ports Conducted Interference Measurement of Shenzhen Huatongwei International Inspection Co., Ltd. has been registered in accordance with the Regulations for Voluntary Control Measures with Registration No.: C-2726. Date of Registration: Dec. 20, 2012. Valid time is until Dec. 19, 2015.

Telecommunication Ports Conducted Interference Measurement of Shenzhen Huatongwei International Inspection Co., Ltd. has been registered in accordance with the Regulations for Voluntary Control Measures with Registration No.: T-1837. Date of Registration: May 07, 2013. Valid time is until May 06, 2016.

DNV

Shenzhen Huatongwei International Inspection Co., Ltd. has been found to comply with the requirements of DNV towards subcontractor of EMC and safety testing services in conjunction with the EMC and Low voltage Directives and in the voluntary field. The acceptance is based on a formal quality Audit and follow-ups according to relevant parts of ISO/IEC Guide 17025 (2005), in accordance with the requirements of the DNV Laboratory Quality Manual towards subcontractors. Valid time is until Aug. 24, 2016.

3.3. Environmental conditions

During the measurement the environmental conditions were within the listed ranges:

| | |
|--------------------|-------------|
| Temperature: | 15~35°C |
| Relative Humidity: | 30~60 % |
| Air Pressure: | 950~1050mba |

3.4. Statement of the measurement uncertainty

The data and results referenced in this document are true and accurate. The reader is cautioned that there may be errors within the calibration limits of the equipment and facilities. The measurement uncertainty was calculated for all measurements listed in this test report according to TR-100028-01 "Electromagnetic compatibility and Radio spectrum Matters (ERM); Uncertainties in the measurement of mobile radio equipment characteristics; Part 1" and TR-100028-02 "Electromagnetic compatibility and Radio spectrum Matters (ERM); Uncertainties in the measurement of mobile radio equipment characteristics; Part 2" and is documented in the Shenzhen Huatongwei International Inspection Co., Ltd quality system according to DIN EN ISO/IEC 17025. Furthermore, component and process variability of devices similar to that tested may result in additional deviation. The manufacturer has the sole responsibility of continued compliance of the device.

Hereafter the best measurement capability for Shenzhen Huatongwei laboratory is reported:

| Test Items | Measurement Uncertainty | Notes |
|---|-------------------------|-------|
| Transmitter power conducted | 0.57 dB | (1) |
| Transmitter power Radiated | 2.20 dB | (1) |
| Conducted spurious emission 9KHz-40 GHz | 1.60 dB | (1) |
| Radiated spurious emission 9KHz-40 GHz | 2.20 dB | (1) |
| Conducted Emission 9KHz-30MHz | 3.39 dB | (1) |
| Radiated Emission 30~1000MHz | 4.24 dB | (1) |
| Radiated Emission 1~18GHz | 5.16 dB | (1) |
| Radiated Emission 18-40GHz | 5.54 dB | (1) |
| Occupied Bandwidth | ----- | (1) |

(1) This uncertainty represents an expanded uncertainty expressed at approximately the 95% confidence level using a coverage factor of $k=1.96$.

3.5. Equipments Used during the Test

| AC Power Conducted Emission | | | | | |
|-----------------------------|-------------------|---------------|-------------|------------|------------|
| Item | Test Equipment | Manufacturer | Model No. | Serial No. | Cal Due |
| 1 | Artificial Mains | Rohde&Schwarz | ESH2-Z5 | 100028 | 2015/11/01 |
| 2 | EMI Test Receiver | Rohde&Schwarz | ESCI3 | 100038 | 2015/11/01 |
| 3 | Pulse Limiter | Rohde&Schwarz | ESHSZ2 | 100044 | 2015/11/01 |
| 4 | EMI Test Software | Rohde&Schwarz | ES-K1 V1.71 | N/A | N/A |

| Radiated Emission | | | | | |
|-------------------|-------------------------|------------------------------|--------------------|------------|------------|
| Item | Test Equipment | Manufacturer | Model No. | Serial No. | Cal Due |
| 1 | Ultra-Broadband Antenna | ShwarzBeck | VULB9163 | 538 | 2015/11/01 |
| 2 | EMI TEST RECEIVER | Rohde&Schwarz | ESI 26 | 100009 | 2015/11/01 |
| 3 | EMI TEST Software | Audix | E3 | N/A | N/A |
| 4 | TURNTABLE | ETS | 2088 | 2149 | N/A |
| 5 | ANTENNA MAST | ETS | 2075 | 2346 | N/A |
| 6 | EMI TEST Software | Rohde&Schwarz | ESK1 | N/A | N/A |
| 7 | HORN ANTENNA | ShwarzBeck | 9120D | 1011 | 2015/11/01 |
| 8 | Amplifer | Sonoma | 310N | E009-13 | 2015/11/01 |
| 9 | JS amplifer | Rohde&Schwarz | JS4-00101800-28-5A | F201504 | 2015/11/01 |
| 10 | High pass filter | Compliance Direction systems | BSU-6 | 34202 | 2015/11/01 |
| 11 | HORN ANTENNA | ShwarzBeck | 9120D | 1012 | 2015/11/01 |
| 12 | Amplifer | Compliance Direction systems | PAP1-4060 | 120 | 2015/11/01 |
| 13 | Loop Antenna | Rohde&Schwarz | HFH2-Z2 | 100020 | 2015/11/01 |
| 14 | TURNTABLE | MATURO | TT2.0 | ---- | N/A |
| 15 | ANTENNA MAST | MATURO | TAM-4.0-P | ---- | N/A |
| 16 | Horn Antenna | SCHWARZBECK | BBHA9170 | 25841 | 2015/11/01 |
| 17 | ULTRA-BROADBAND ANTENNA | Rohde&Schwarz | HL562 | 100015 | 2015/11/01 |

| Maximum Peak Output Power / Power Spectral Density / 6dB Bandwidth / Band Edge Compliance of RF Emission / Spurious RF Conducted Emission | | | | | |
|---|-------------------|---------------|-----------|--------------|------------|
| Item | Test Equipment | Manufacturer | Model No. | Serial No. | Cal Due |
| 1 | Spectrum Analyzer | Rohde&Schwarz | FSP | 1164.4391.40 | 2015/11/01 |
| 2 | Power Meter | Anritsu | MA2411B | 100258 | 2015/11/01 |

The Cal.Interval was one year

4. TEST CONDITIONS AND RESULTS

4.1. Antenna requirement

Requirement

FCC CFR Title 47 Part 15 Subpart C Section 15.203:

An intentional radiator shall be designed to ensure that no antenna other than that furnished by the responsible party shall be used with the device. The use of a permanently attached antenna or of an antenna that uses a unique coupling to the intentional radiator, the manufacturer may design the unit so that a broken antenna can be replaced by the user, but the use of a standard antenna jack or electrical connector is prohibited.

FCC CFR Title 47 Part 15 Subpart C Section 15.247(c) (1)(i):

(i) Systems operating in the 2400-2483.5 MHz band that is used exclusively for fixed. Point-to-point operations may employ transmitting antennas with directional gain greater than 6dBi provided the maximum conducted output power of the intentional radiator is reduced by 1 dB for every 3 dB that the directional gain of the antenna exceeds 6dBi.

Test Result:

The antenna is integral antenna, the best case gain of the antenna is 2.0dBi

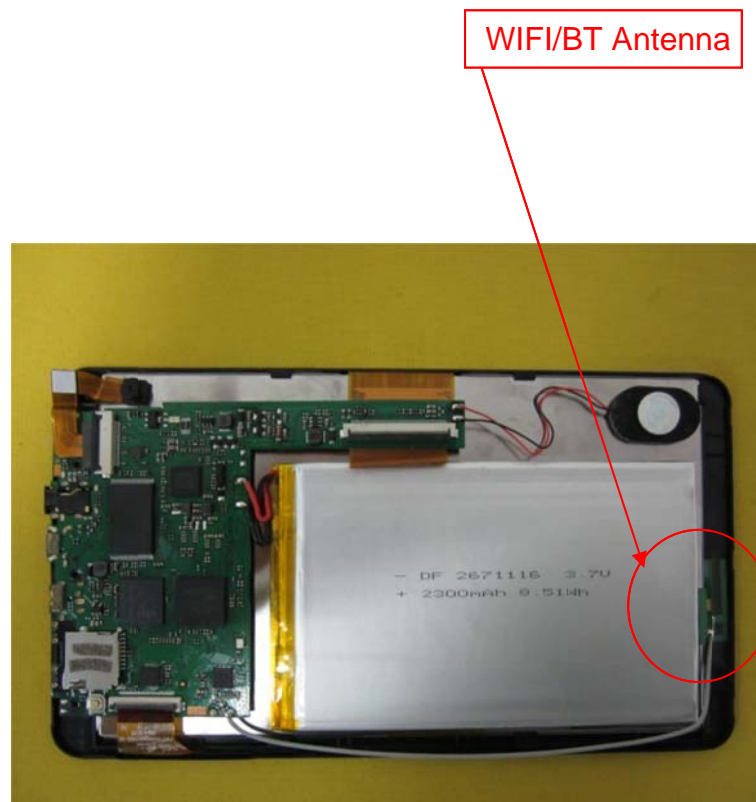

4.2. Conducted Emission (AC Main)

LIMIT

FCC CFR Title 47 Part 15 Subpart C Section 15.207

| Frequency range (MHz) | Limit (dBuV) | |
|-----------------------|--------------|-----------|
| | Quasi-peak | Average |
| 0.15-0.5 | 66 to 56* | 56 to 46* |
| 0.5-5 | 56 | 46 |
| 5-30 | 60 | 50 |

* Decreases with the logarithm of the frequency.

TEST CONFIGURATION

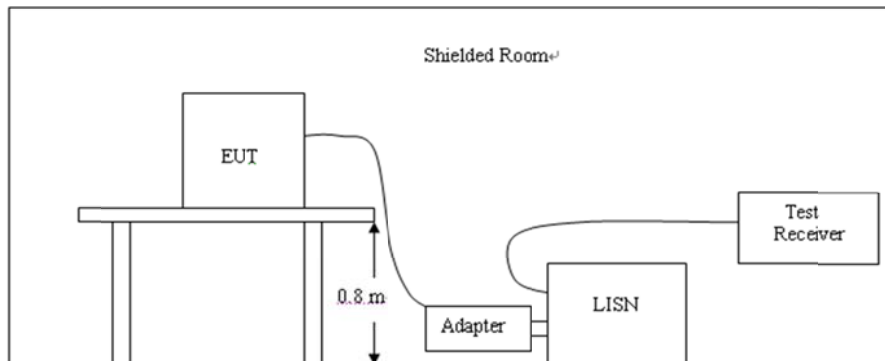

TEST PROCEDURE

1. The EUT was setup according to ANSI C63.4: 2009 and tested according to ANSI C63.10:2009 for compliance to FCC 47CFR 15.247 requirements.
2. The EUT was placed on a platform of nominal size, 1 m by 1.5 m, raised 80 cm above the conducting ground plane. The vertical conducting plane was located 40 cm to the rear of the EUT. All other surfaces of EUT were at least 80 cm from any other grounded conducting surface.
3. The EUT and simulators are connected to the main power through a line impedance stabilization network (LISN). The LISN provides a 50 ohm /50uH coupling impedance for the measuring equipment.
4. The peripheral devices are also connected to the main power through a LISN. (Please refer to the block diagram of the test setup and photographs)
5. Each current-carrying conductor of the EUT power cord, except the ground (safety) conductor, was individually connected through a LISN to the input power source.
6. The excess length of the power cord between the EUT and the LISN receptacle were folded back and forth at the center of the lead to form a bundle not exceeding 40 cm in length.
7. Conducted emissions were investigated over the frequency range from 0.15MHz to 30MHz using a receiver bandwidth of 9 kHz.

TEST RESULTS

| | | | |
|------------|------|--------------|---|
| Test mode: | WIFI | Polarization | L |
|------------|------|--------------|---|

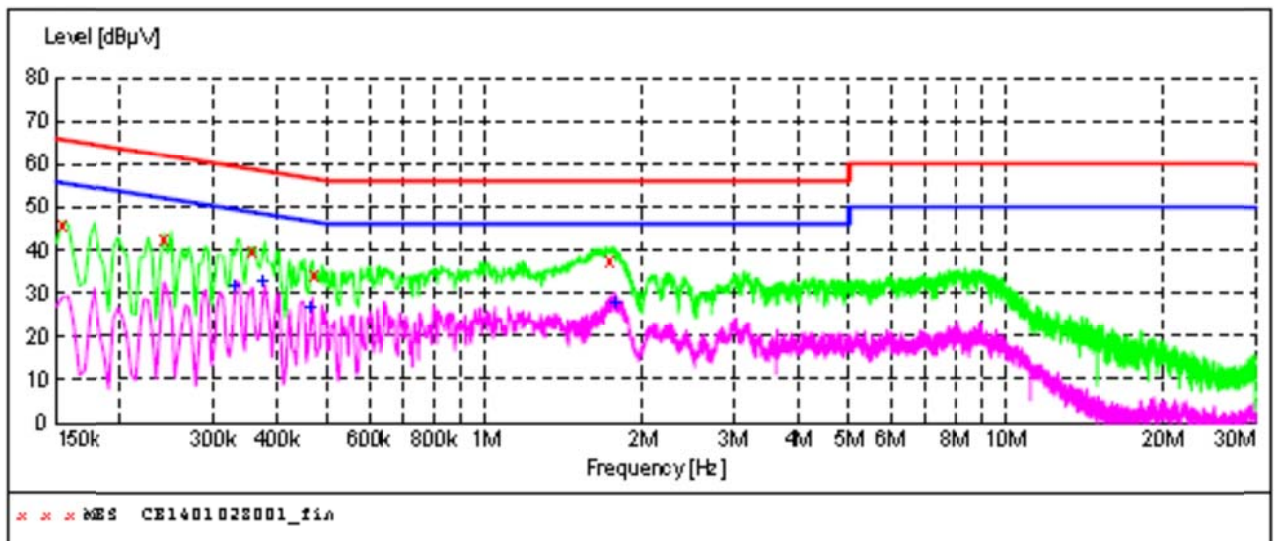

MEASUREMENT RESULT: "CE1401028001_fir"

10/28/2014 10:15AM

| Frequency MHz | Level dBµV | Transd dB | Limit dBµV | Margin dB | Detector | Line | PE |
|------------------|---------------|--------------|---------------|--------------|----------|------|-----|
| 0.154000 | 46.00 | 12.3 | 66 | 19.8 | QP | L1 | GND |
| 0.242000 | 42.50 | 11.8 | 62 | 19.5 | QP | L1 | GND |
| 0.358000 | 39.50 | 10.9 | 59 | 19.3 | QP | L1 | GND |
| 0.470000 | 34.10 | 10.1 | 57 | 22.4 | QP | L1 | GND |
| 1.726000 | 37.60 | 10.1 | 56 | 18.4 | QP | L1 | GND |

MEASUREMENT RESULT: "CE1401028001_fir2"

10/28/2014 10:15AM

| Frequency MHz | Level dBµV | Transd dB | Limit dBµV | Margin dB | Detector | Line | PE |
|------------------|---------------|--------------|---------------|--------------|----------|------|-----|
| 0.330000 | 31.90 | 11.2 | 50 | 17.6 | AV | L1 | GND |
| 0.374000 | 32.90 | 10.8 | 48 | 15.5 | AV | L1 | GND |
| 0.462000 | 27.10 | 10.1 | 47 | 19.6 | AV | L1 | GND |
| 1.770000 | 27.90 | 10.1 | 46 | 18.1 | AV | L1 | GND |

| | | | |
|------------|------|--------------|---|
| Test mode: | WIFI | Polarization | N |
|------------|------|--------------|---|

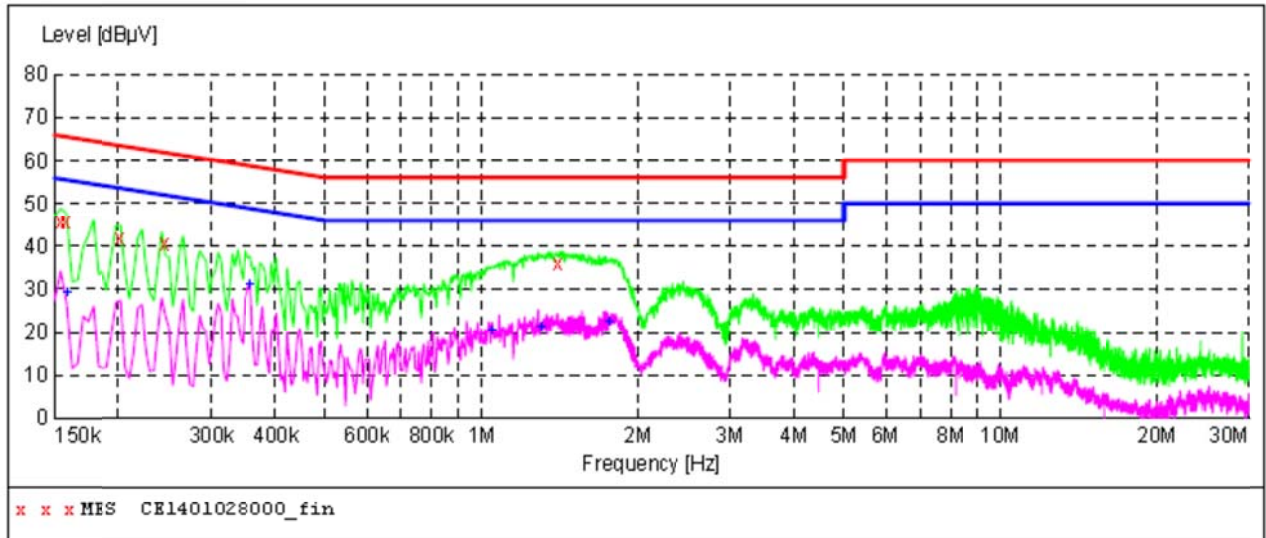

MEASUREMENT RESULT: "CE1401028000_fin"

10/28/2014 10:11AM

| Frequency MHz | Level dBµV | Transd dB | Limit dBµV | Margin dB | Detector | Line | PE |
|---------------|------------|-----------|------------|-----------|----------|------|-----|
| 0.154000 | 45.80 | 12.3 | 66 | 20.0 | QP | N | GND |
| 0.158000 | 45.80 | 12.3 | 66 | 19.8 | QP | N | GND |
| 0.202000 | 42.00 | 12.0 | 64 | 21.5 | QP | N | GND |
| 0.246000 | 40.90 | 11.8 | 62 | 21.0 | QP | N | GND |
| 1.406000 | 36.20 | 10.1 | 56 | 19.8 | QP | N | GND |

MEASUREMENT RESULT: "CE1401028000_fin2"

10/28/2014 10:11AM

| Frequency MHz | Level dBµV | Transd dB | Limit dBµV | Margin dB | Detector | Line | PE |
|---------------|------------|-----------|------------|-----------|----------|------|-----|
| 0.158000 | 29.20 | 12.3 | 56 | 26.4 | AV | N | GND |
| 0.358000 | 31.10 | 10.9 | 49 | 17.7 | AV | N | GND |
| 1.046000 | 20.40 | 10.1 | 46 | 25.6 | AV | N | GND |
| 1.298000 | 21.30 | 10.1 | 46 | 24.7 | AV | N | GND |
| 1.754000 | 22.60 | 10.1 | 46 | 23.4 | AV | N | GND |

4.3. Conducted Peak Output Power

LIMIT

FCC CFR Title 47 Part 15 Subpart C Section 15.247 (b)(3): **30dBm**

TEST CONFIGURATION



TEST PROCEDURE

1. The EUT was tested according to ANSI C63.10: 2009 and KDB 558074 D01 V03R02 for compliance to FCC 47CFR 15.247 requirements.
2. Use the wideband power meter to test peak power and record the result.

TEST RESULTS

| Type | Channel | Output power (dBm) | Limit (dBm) | Result |
|--------------|---------|--------------------|-------------|--------|
| 802.11b | 01 | 15.95 | 30.00 | Pass |
| | 06 | 16.15 | | |
| | 11 | 16.39 | | |
| 802.11g | 01 | 14.17 | 30.00 | Pass |
| | 06 | 14.51 | | |
| | 11 | 14.75 | | |
| 802.11n(H20) | 01 | 13.81 | 30.00 | Pass |
| | 06 | 13.77 | | |
| | 11 | 13.27 | | |
| 802.11n(H40) | 03 | 12.33 | 30.00 | Pass |
| | 06 | 12.47 | | |
| | 09 | 12.52 | | |

4.4. Power Spectral Density

LIMIT

FCC CFR Title 47 Part 15 Subpart C Section 15.247 (e): **8dBm/3KHz**

For digitally modulated systems, the power spectral density conducted from the intentional radiator to the antenna shall not be greater than 8 dBm in any 3 kHz band during any time interval of continuous transmission.

TEST CONFIGURATION



TEST PROCEDURE

1. According to KDB 558074 D01 V03R02 Method PKPSD (peak PSD) This procedure shall be used if maximum peak conducted output power was used to demonstrate compliance, and is optional if the maximum conducted (average) output power was used to demonstrate compliance.
2. Analyzer set:
Center frequency =Channel center frequency
RBW =3 kHz~100 kHz, VBW≥3RBW, Detector=Peak, Span=1.5 times the bandwidth
3. Allow trace to fully stabilize, use the peak marker function to determine the maximum amplitude level within the RBW.
4. If measured value exceeds limit, reduce RBW (no less than 3 kHz) and repeat.

TEST RESULTS

| Type | Channel | Power Spectral Density (dBm/3KHz) | Limit (dBm/3KHz) | Result |
|--------------|---------|-----------------------------------|------------------|--------|
| 802.11b | 01 | -10.67 | 8.00 | Pass |
| | 06 | -10.06 | | |
| | 11 | -10.12 | | |
| 802.11g | 01 | -15.71 | 8.00 | Pass |
| | 06 | -15.58 | | |
| | 11 | -15.33 | | |
| 802.11n(H20) | 01 | -15.61 | 8.00 | Pass |
| | 06 | -15.67 | | |
| | 11 | -15.60 | | |
| 802.11n(H40) | 03 | -20.29 | 8.00 | Pass |
| | 06 | -19.70 | | |
| | 09 | -20.01 | | |

Test plot as follows:

802.11b

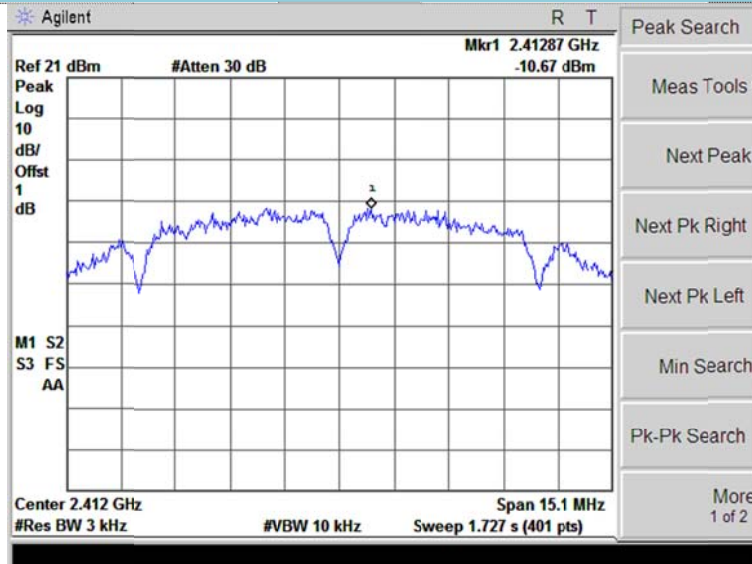

CH01

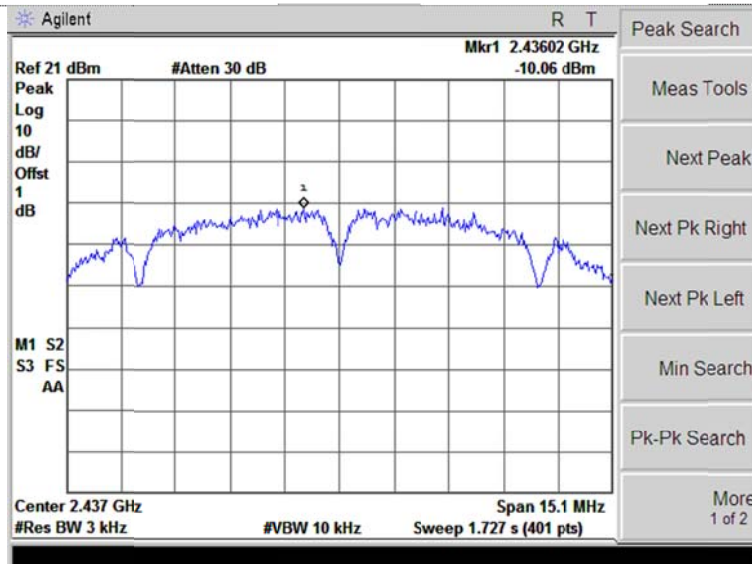

CH06

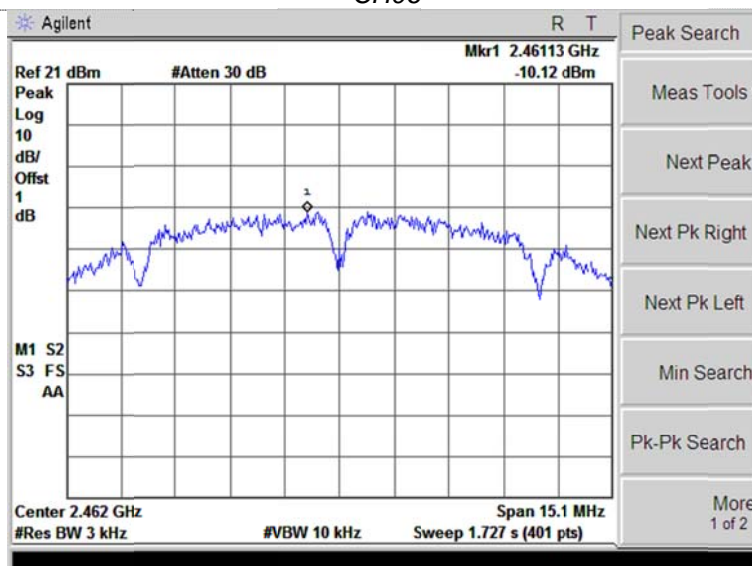

CH11

802.11g

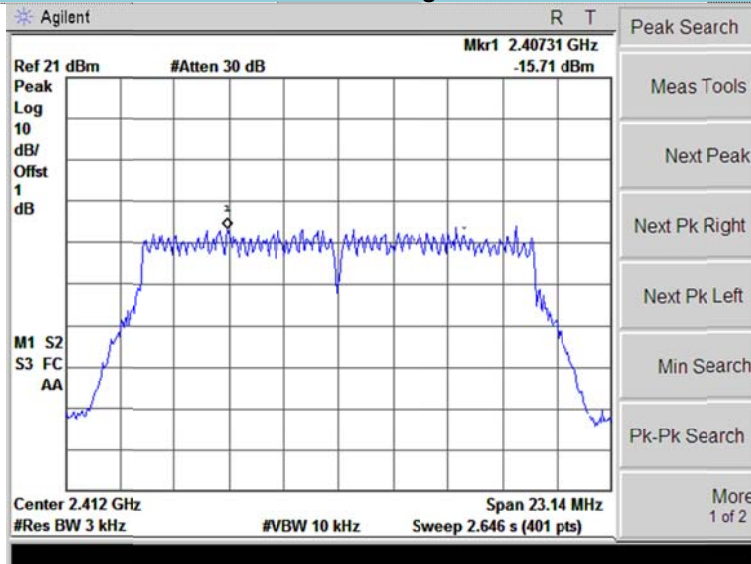

CH01

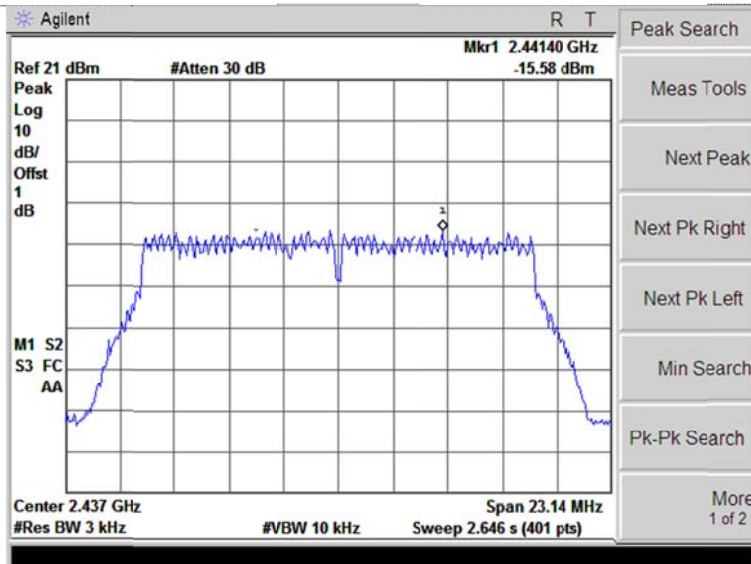

CH06

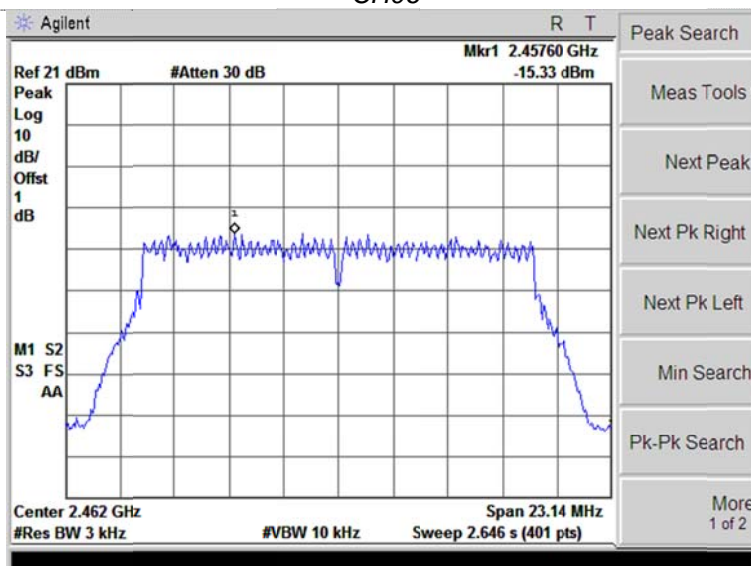

CH11

802.11n(H20)

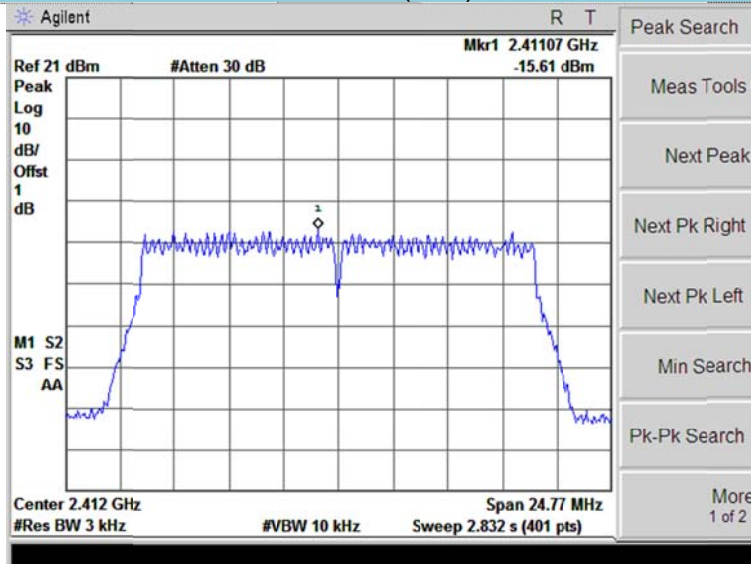

CH01

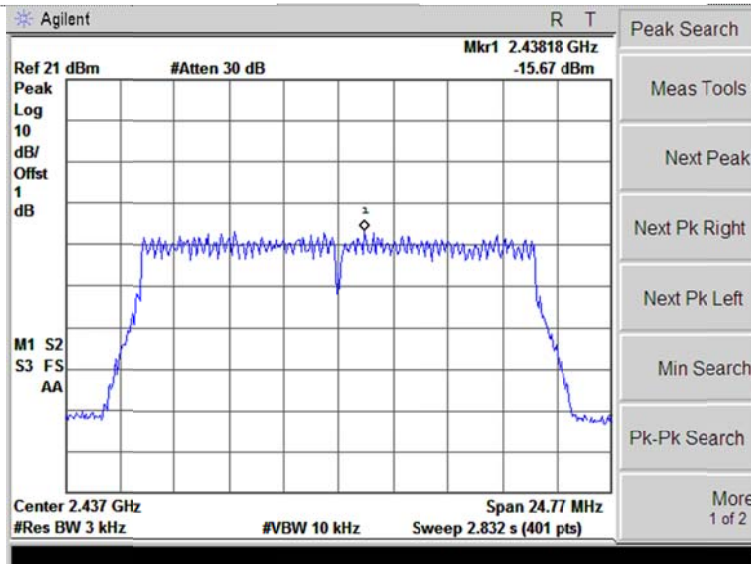

CH06

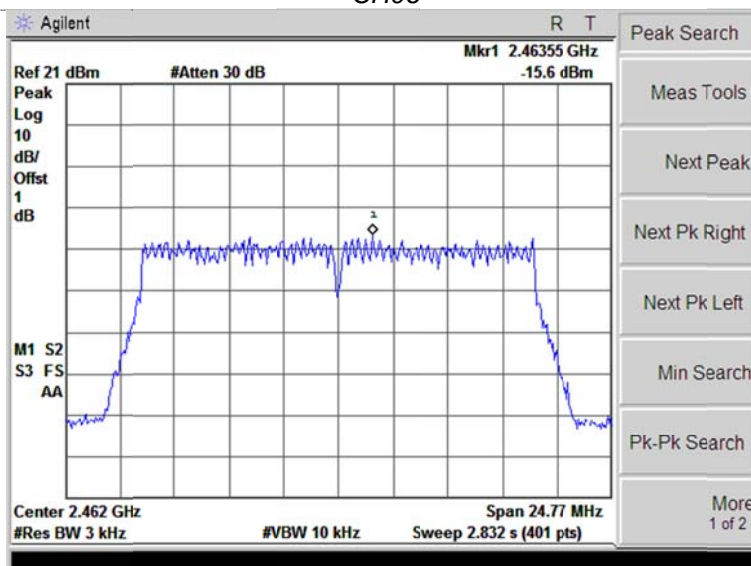

CH11

802.11n(H40)

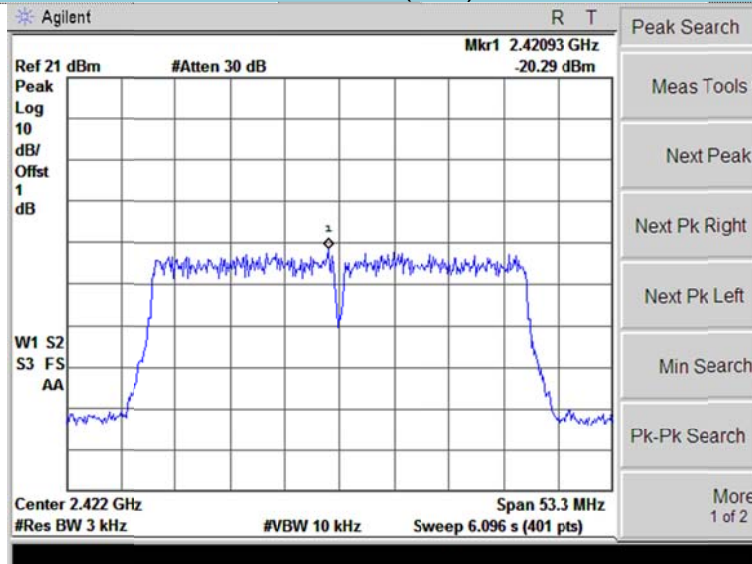

CH03

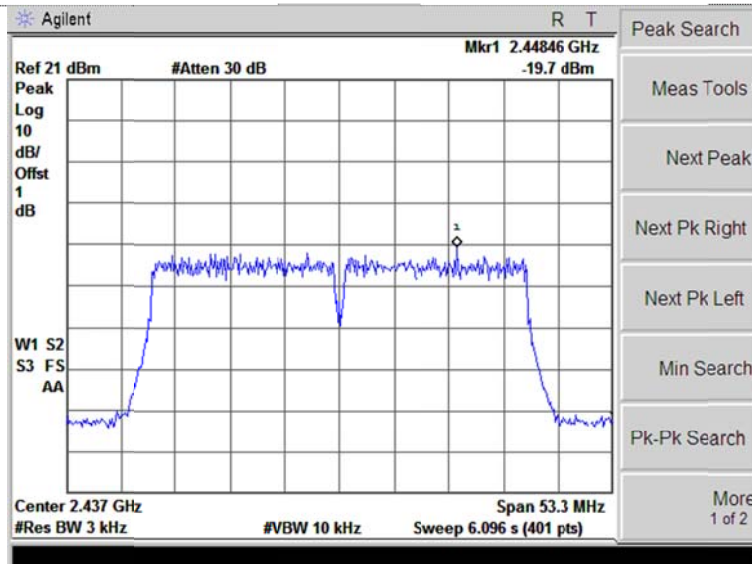

CH06

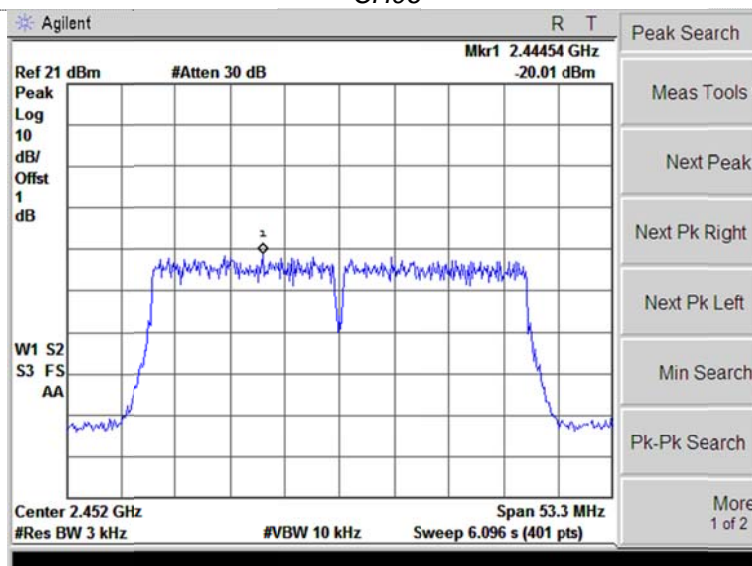

CH09

4.5. 6dB bandwidth

LIMIT

FCC CFR Title 47 Part 15 Subpart C Section 15.247 (a)(2): **at least 500KHz**

For digital modulation systems, the minimum 6 dB bandwidth shall be at least 500 kHz.

TEST CONFIGURATION

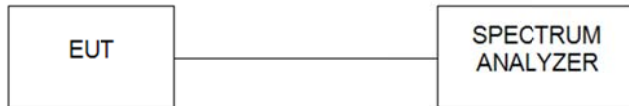

TEST PROCEDURE

1. The transmitter output was connected to the spectrum analyzer through an attenuator. The bandwidth of the fundamental frequency was measured by spectrum analyzer
2. The 6dB bandwidth is defined as the total spectrum the power of which is higher than peak power minus 6dB.
3. According to KDB 558074 D01 V03R02 for one of the following procedures may be used to determine the modulated DTS device signal bandwidth.
Center frequency =Channel center frequency
RBW =100 kHz, VBW \geq 3RBW, Detector=Peak,
4. Allow the trace to stabilize.
5. Measure the maximum width of the emission that is constrained by the frequencies associated with the two outermost amplitude points (upper and lower frequencies) that are attenuated by 6 dB relative to the maximum level measured in the fundamental emission.

TEST RESULTS

| Type | Channel | 6dB Bandwidth(MHz) | Limit (KHz) | Result |
|--------------|---------|--------------------|-------------|--------|
| 802.11b | 01 | 9.11 | \geq 500 | Pass |
| | 06 | 10.06 | | |
| | 11 | 10.06 | | |
| 802.11g | 01 | 15.12 | \geq 500 | Pass |
| | 06 | 15.42 | | |
| | 11 | 15.39 | | |
| 802.11n(H20) | 01 | 16.31 | \geq 500 | Pass |
| | 06 | 16.51 | | |
| | 11 | 16.07 | | |
| 802.11n(H40) | 03 | 35.42 | \geq 500 | Pass |
| | 06 | 35.53 | | |
| | 09 | 35.21 | | |

Test plot as follows:

802.11b

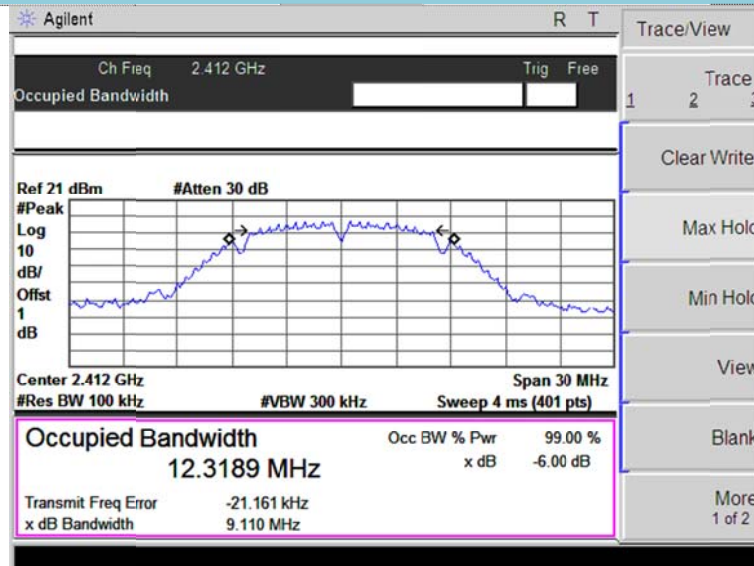

CH01

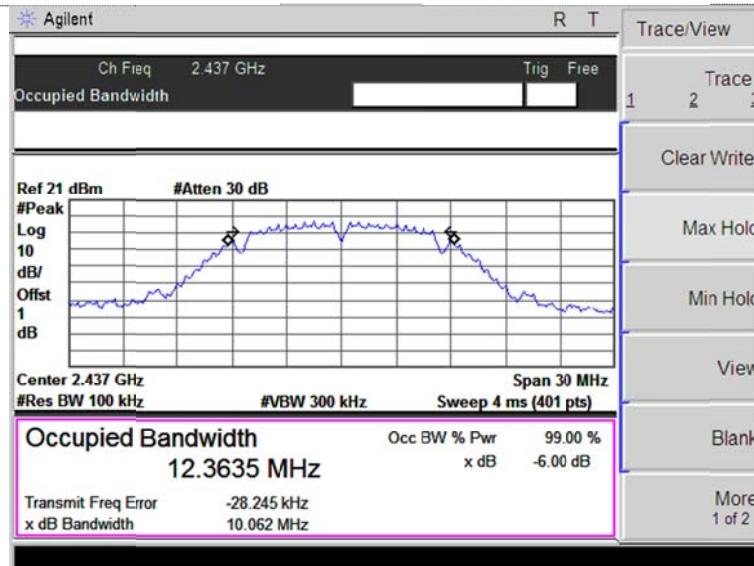

CH06

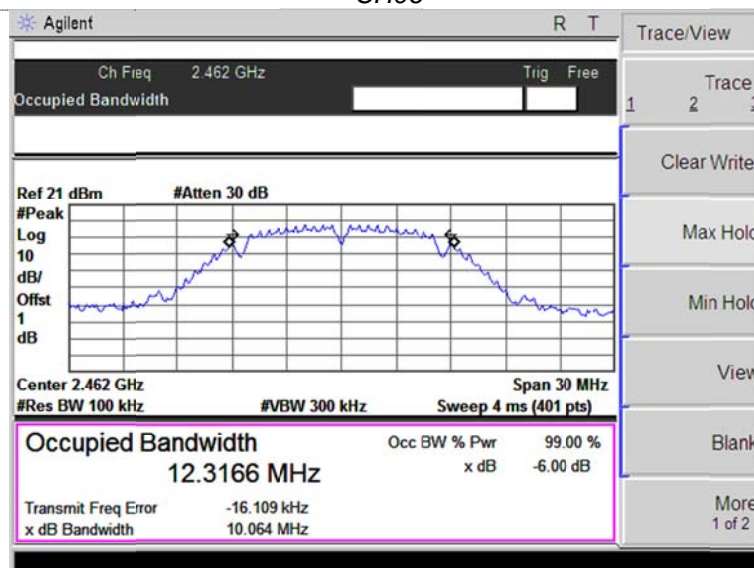

CH11

802.11g

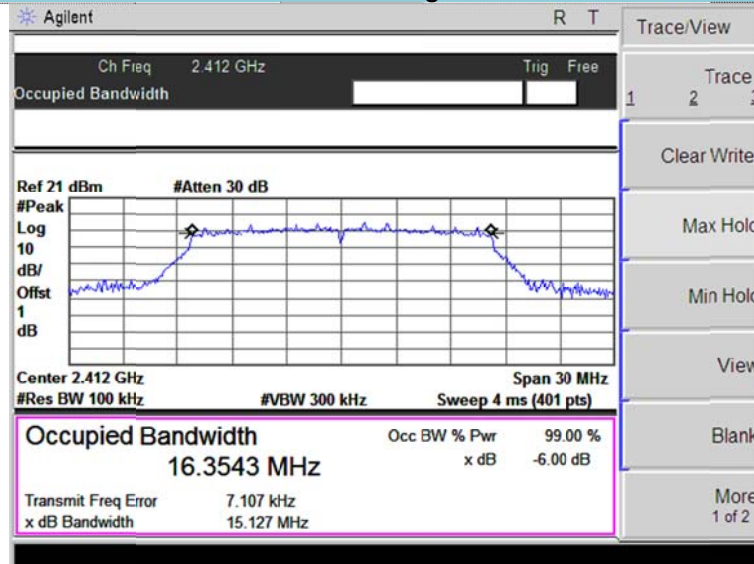

CH01

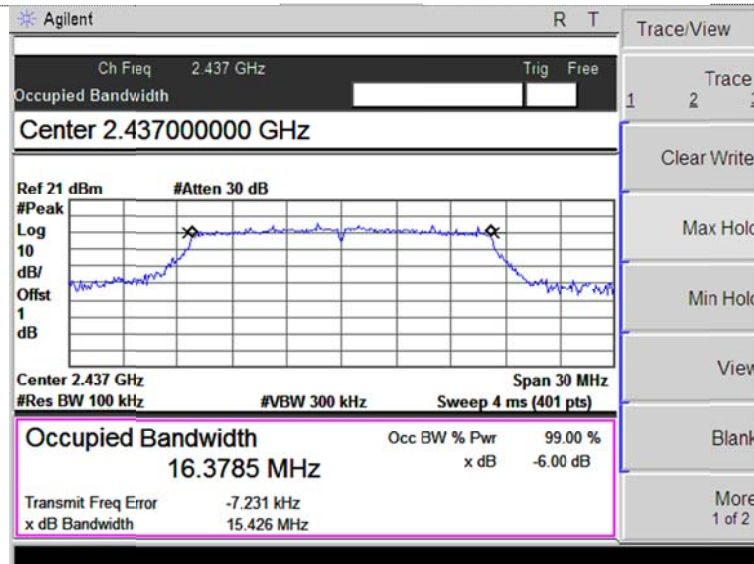

CH06

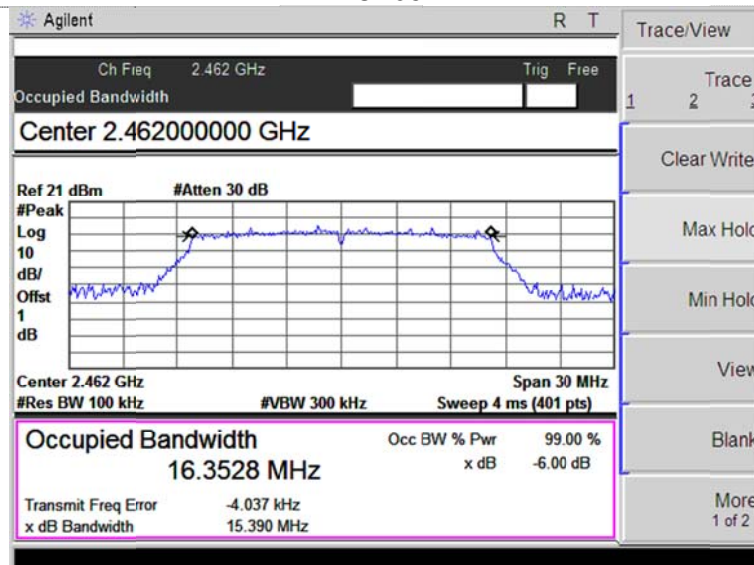

CH11

802.11n(H20)

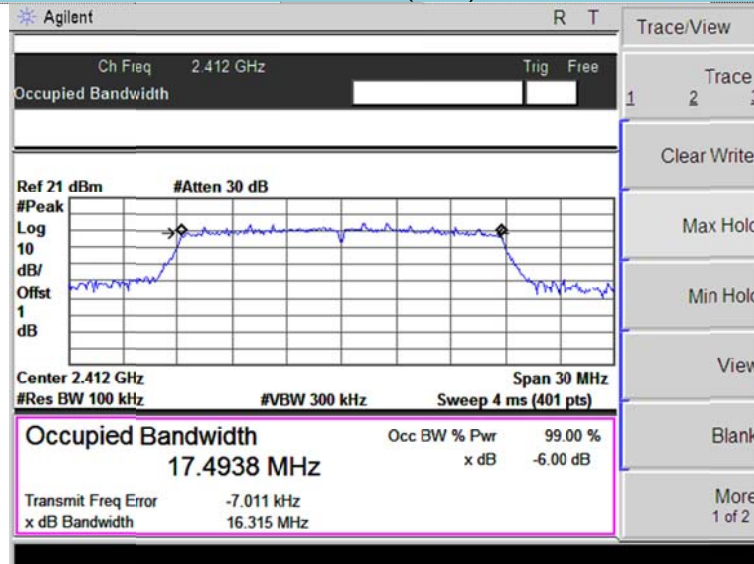

CH01

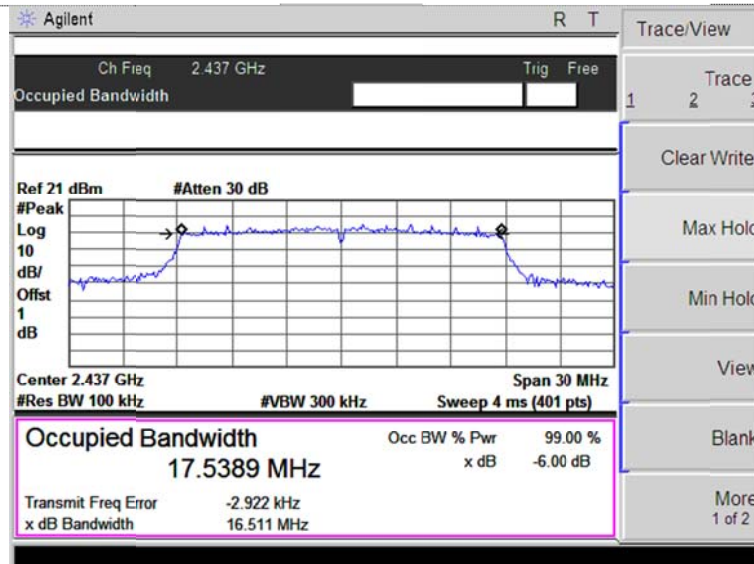

CH06

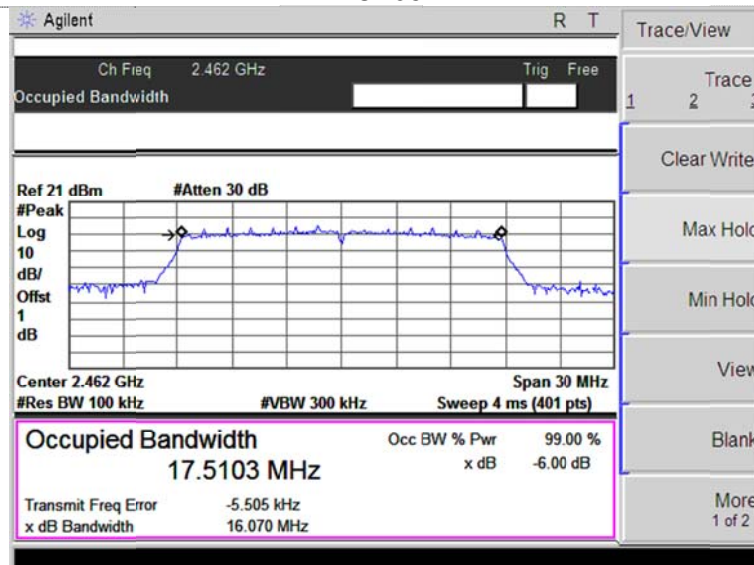

CH11

802.11n(H40)

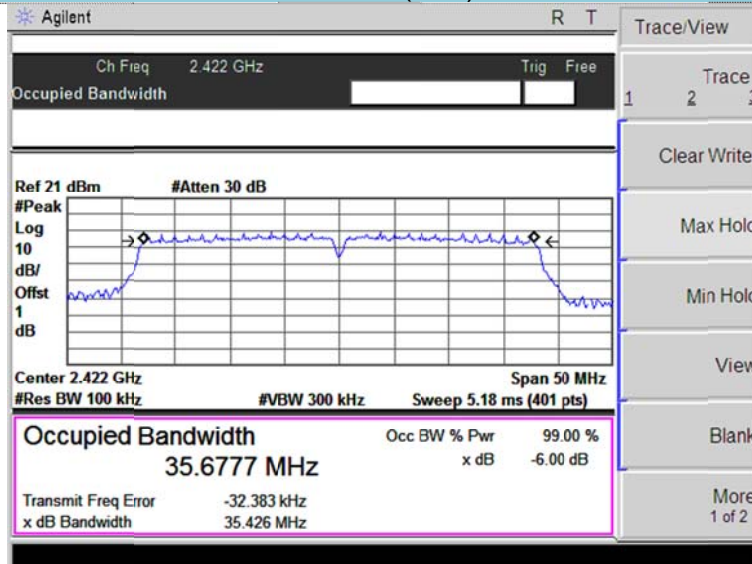

CH03

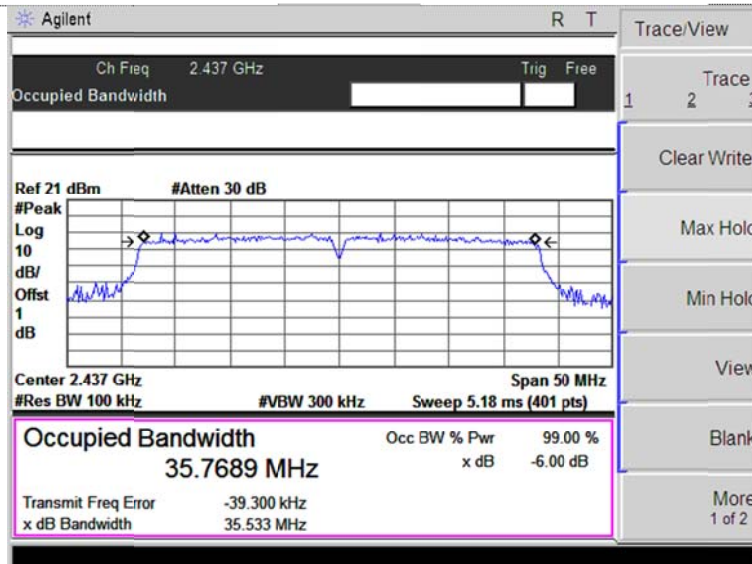

CH06

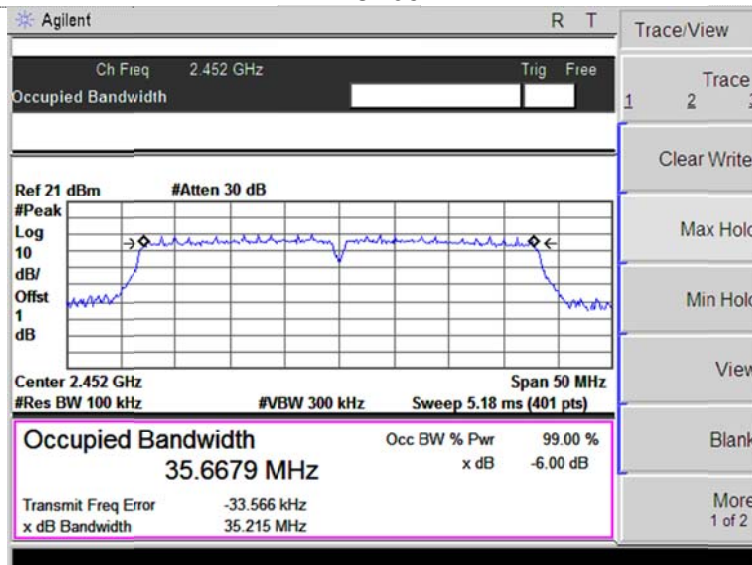

CH09

4.6. Band Edge

LIMIT

FCC CFR Title 47 Part 15 Subpart C Section 15.247 (d):

In any 100 kHz bandwidth outside the frequency band in which the spread spectrum or digitally modulated intentional radiator is operating, the radio frequency power that is produced by the intentional radiator shall be at least 20 dB below that in the 100 kHz bandwidth within the band that contains the highest level of the desired power, based on either an RF conducted or a radiated measurement, provided the transmitter demonstrates compliance with the peak conducted power limits. If the transmitter complies with the conducted power limits based on the use of RMS averaging over a time interval, as permitted under paragraph (b)(3) of this section, the attenuation required under this paragraph shall be 30 dB instead of 20 dB. Attenuation below the general limits specified in §15.209(a) is not required. In addition, radiated emissions which fall in the restricted bands, as defined in §15.205(a), must also comply with the radiated emission limits specified in §15.209(a) (see §15.205(c)).

TEST CONFIGURATION



TEST PROCEDURE

1. According to KDB 558074 D01 V03R02 for Antenna-port conducted measurement. Antenna-port conducted measurements may also be used as an alternative to radiated measurements for demonstrating compliance in the restricted frequency bands. If conducted measurements are performed, then proper impedance matching must be ensured and an additional radiated test for cabinet/case spurious emissions is required.
2. Remove the antenna from the EUT and then connect to a low loss RF cable from the antenna port to a EMI test receiver, then turn on the EUT and make it operate in transmitting mode. Then set it to Low Channel and High Channel within its operating range, and make sure the instrument is operated in its linear range.
3. Set both RBW and VBW of spectrum analyzer to 100 kHz with a convenient frequency span including 100kHz bandwidth from band edge, for Radiated emissions restricted band RBW=1MHz, VBW=3MHz for peak detector and RBW=1MHz, VBW=10Hz, Peak detector for average measurement.
4. Measure the highest amplitude appearing on spectral display and set it as a reference level. Plot the graph with marking the highest point and edge frequency.
5. Repeat above procedures until all measured frequencies were complete.
6. Measure the conducted output power (in dBm) using the detector specified by the appropriate regulatory agency
7. Add the maximum transmit antenna gain (in dBi) to the measured output power level to determine the EIRP level
8. Add the appropriate maximum ground reflection factor to the EIRP level (6 dB for frequencies ≤ 30 MHz, 4.7 dB for frequencies between 30 MHz and 1000 MHz, inclusive and 0 dB for frequencies > 1000 MHz).
9. For devices with multiple antenna-ports, measure the power of each individual chain and sum the EIRP of all chains in linear terms (e.g., Watts, mW).
10. Convert the resultant EIRP level to an equivalent electric field strength using the following relationship:

$$E = \text{EIRP} - 20\log D + 104.8$$
 where:
 E = electric field strength in dB μ V/m,
 EIRP = equivalent isotropic radiated power in dBm
 D = specified measurement distance in meters.
11. Since the out-of-band characteristics of the EUT transmit antenna will often be unknown, the use of a conservative antenna gain value is necessary. Thus, when determining the EIRP based on the measured conducted power, the upper bound on antenna gain for a device with a single RF output shall be selected as the maximum in-band gain of the antenna across all operating bands, or 2 dBi, whichever is greater. However, for devices that operate in multiple frequency bands while using the same transmit antenna, the highest gain of the antenna within the operating band nearest in frequency to the restricted band emission being measured may be used in lieu of the overall highest gain when the emission is at a frequency that is within 20 percent of the nearest band edge frequency, but in no case shall a value less than 2 dBi be used.
12. Compare the resultant electric field strength level to the applicable regulatory limit.
13. Perform radiated spurious emission test dures until all measured frequencies were complete.

TEST RESULTS

Mode: 802.11b Test channel: 2412MHz

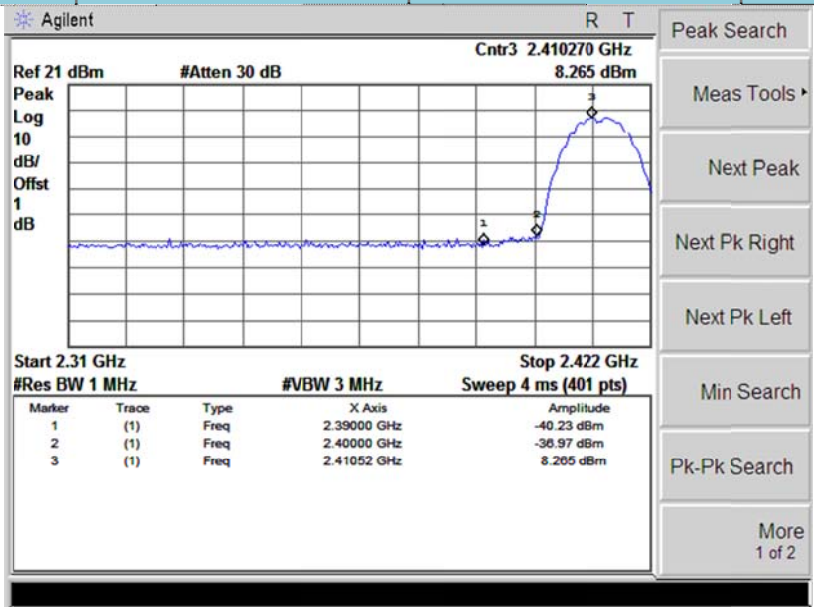

Peak

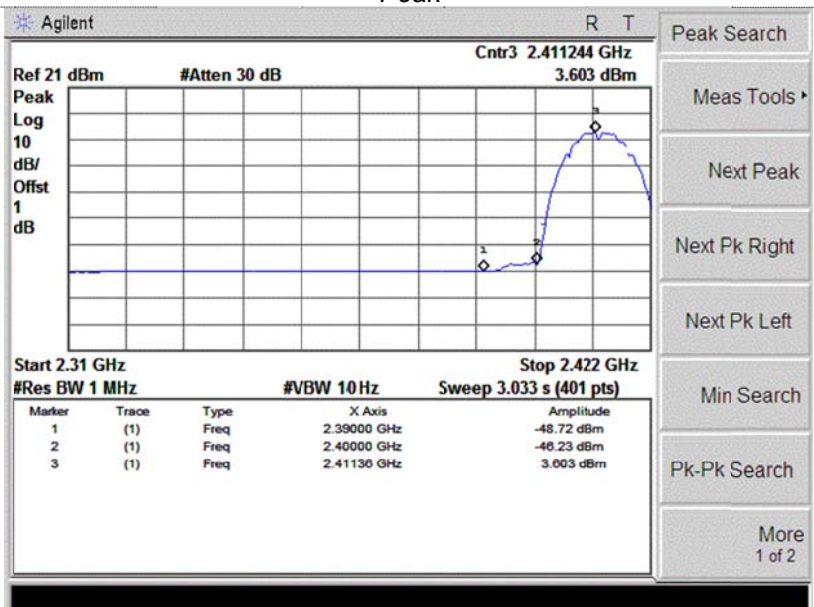

Average

| Frequency (MHz) | Conducted Power (dBm) | Antenna Gain (dBi) | Ground Reflection Factor (dB) | Covert Radiated E Level at 3m (dBuV/m) | Detector | Limit (dBuV/m) | Result |
|-----------------|-----------------------|--------------------|-------------------------------|--|----------|----------------|--------|
| 2390.00 | -40.23 | 2.00 | 0.00 | 57.03 | Peak | 74.00 | Pass |
| 2410.52 | 8.26 | 2.00 | 0.00 | 105.52 | Peak | | Pass |
| 2390.00 | -48.72 | 2.00 | 0.00 | 48.54 | Average | 54.00 | Pass |
| 2411.36 | 3.60 | 2.00 | 0.00 | 100.86 | Average | | Pass |

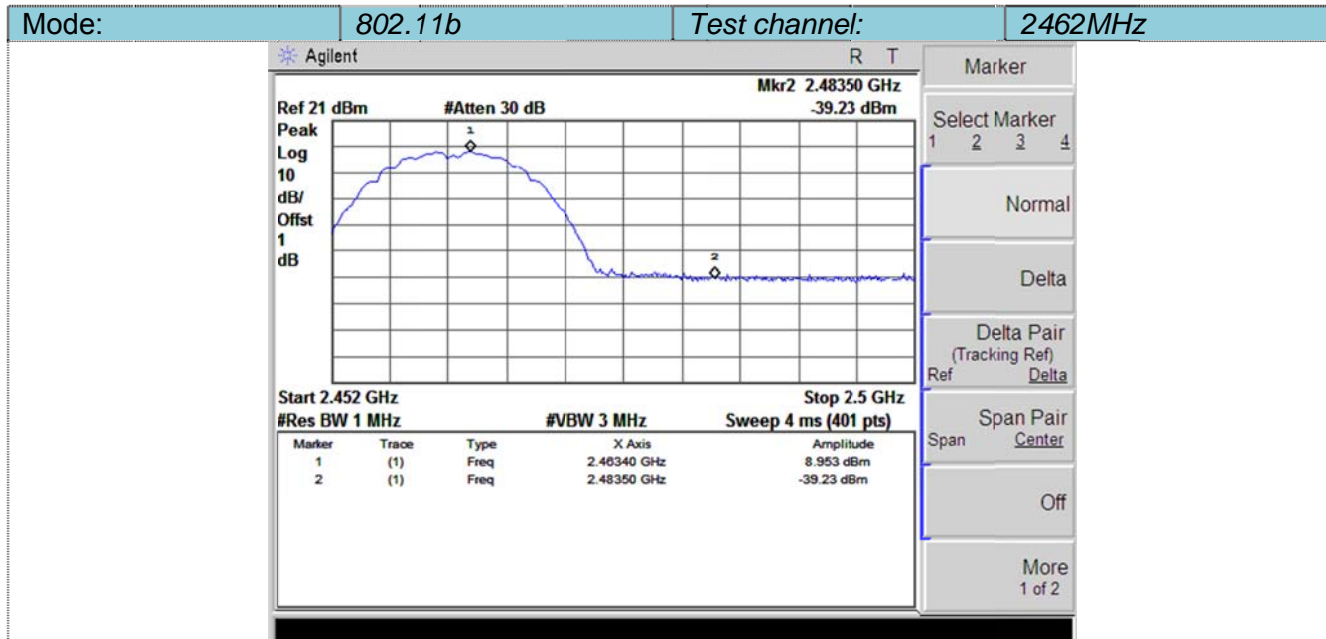

Peak

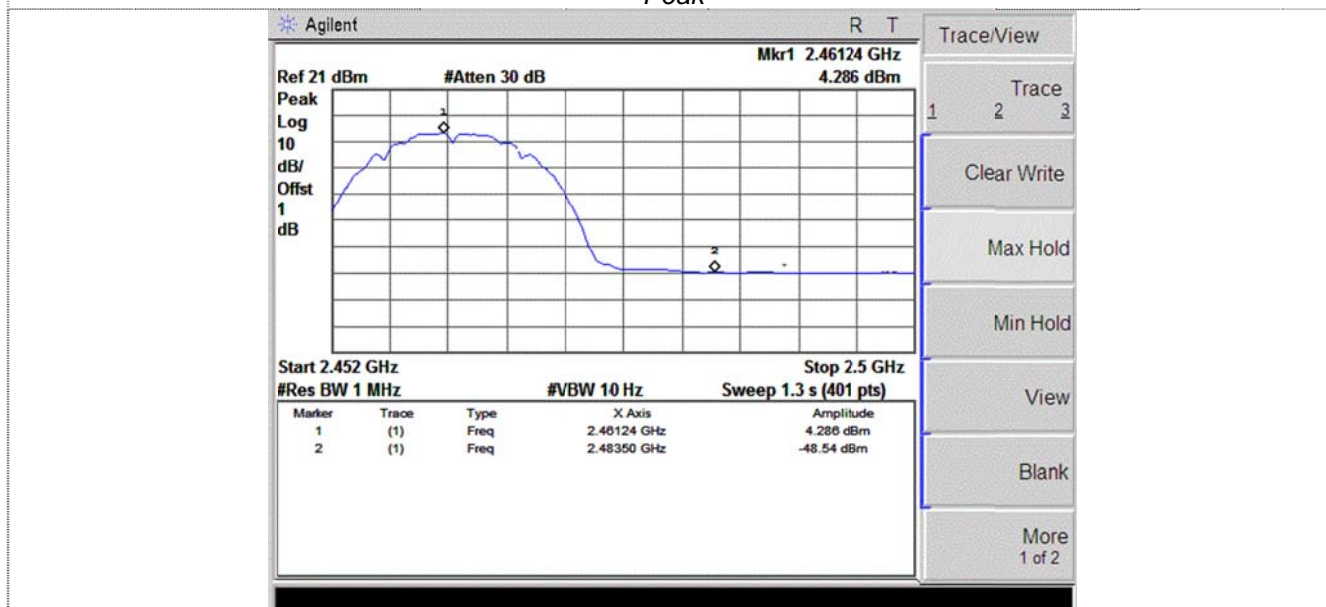

Average

| Frequency (MHz) | Conducted Power (dBm) | Antenna Gain (dBi) | Ground Reflection Factor (dB) | Covert Radiated E Level at 3m (dBuV/m) | Detector | Limit (dBuV/m) | Result |
|-----------------|-----------------------|--------------------|-------------------------------|--|----------|----------------|--------|
| 2463.40 | 8.95 | 2.00 | 0.00 | 106.21 | Peak | | Pass |
| 2483.50 | -39.23 | 2.00 | 0.00 | 58.03 | Peak | 74.00 | Pass |
| 2461.24 | 4.28 | 2.00 | 0.00 | 101.54 | Average | | Pass |
| 2483.50 | -48.54 | 2.00 | 0.00 | 48.72 | Average | 54.00 | Pass |

Mode: 802.11g Test channel: 2412MHz

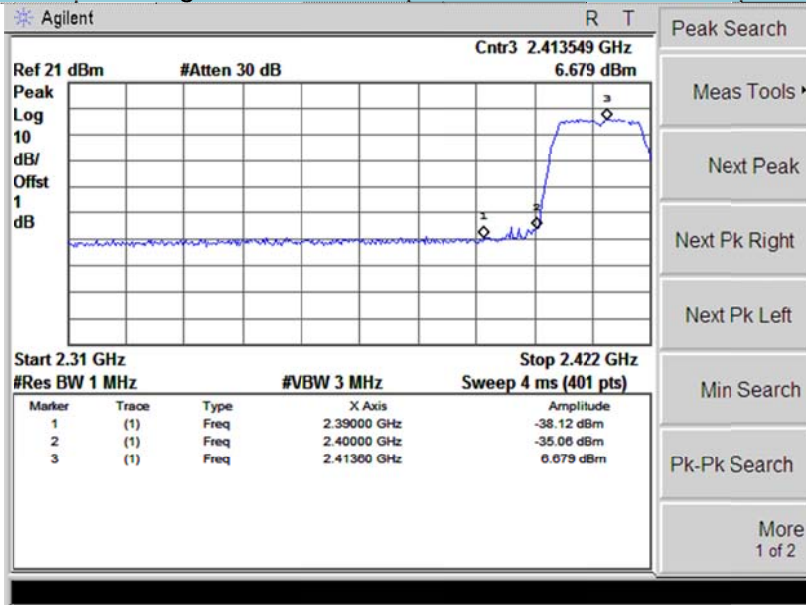

Peak

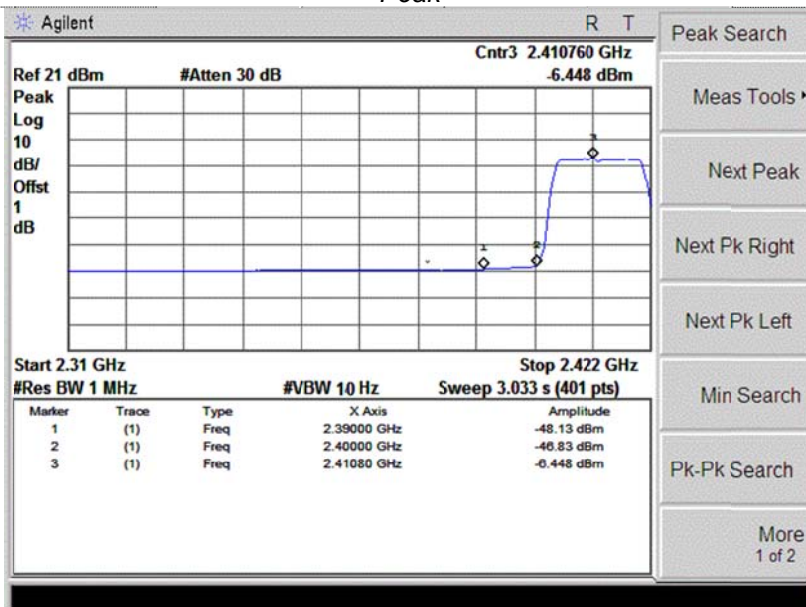

Average

| Frequency (MHz) | Conducted Power (dBm) | Antenna Gain (dBi) | Ground Reflection Factor (dB) | Covert Radiated E Level at 3m (dBuV/m) | Detector | Limit (dBuV/m) | Result |
|-----------------|-----------------------|--------------------|-------------------------------|--|----------|----------------|--------|
| 2390.00 | -38.12 | 2.00 | 0.00 | 59.14 | Peak | 74.00 | Pass |
| 2413.60 | 6.67 | 2.00 | 0.00 | 103.93 | Peak | | Pass |
| 2390.00 | -48.13 | 2.00 | 0.00 | 49.13 | Average | 54.00 | Pass |
| 2410.80 | -6.44 | 2.00 | 0.00 | 90.82 | Average | | Pass |

Mode: 802.11g Test channel: 2462MHz

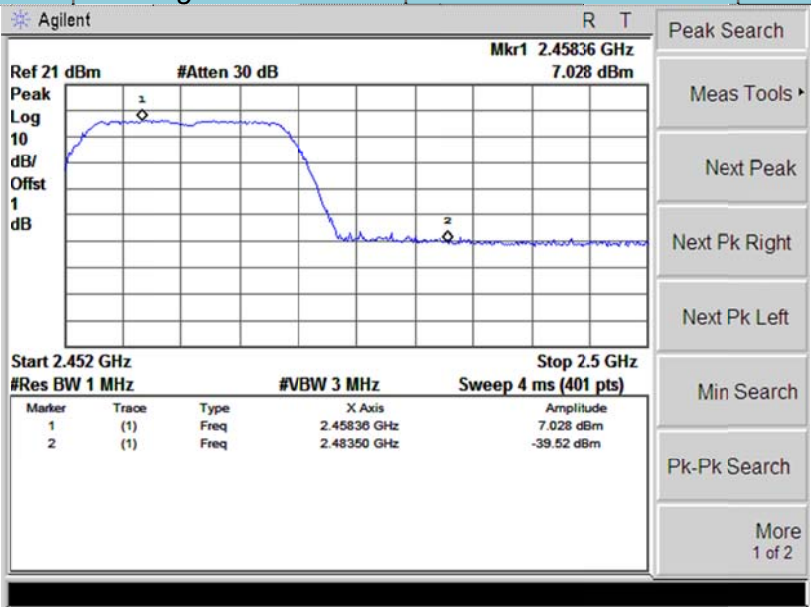

Peak

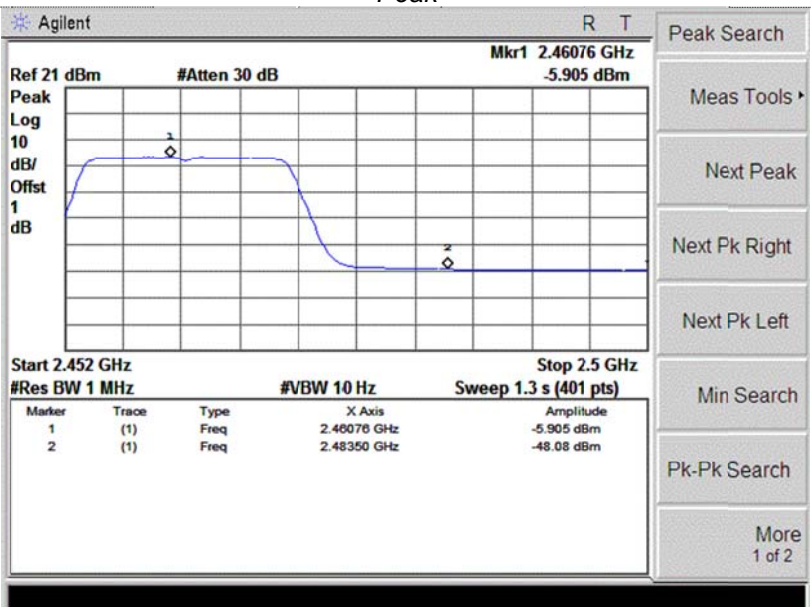

Average

| Frequency (MHz) | Conducted Power (dBm) | Antenna Gain (dBi) | Ground Reflection Factor (dB) | Covert Radiated E Level at 3m (dBuV/m) | Detector | Limit (dBuV/m) | Result |
|-----------------|-----------------------|--------------------|-------------------------------|--|----------|----------------|--------|
| 2458.36 | 7.02 | 2.00 | 0.00 | 104.28 | Peak | | Pass |
| 2483.50 | -39.52 | 2.00 | 0.00 | 57.74 | Peak | 74.00 | Pass |
| 2460.76 | -5.90 | 2.00 | 0.00 | 91.36 | Average | | Pass |
| 2483.50 | -48.08 | 2.00 | 0.00 | 49.18 | Average | 54.00 | Pass |

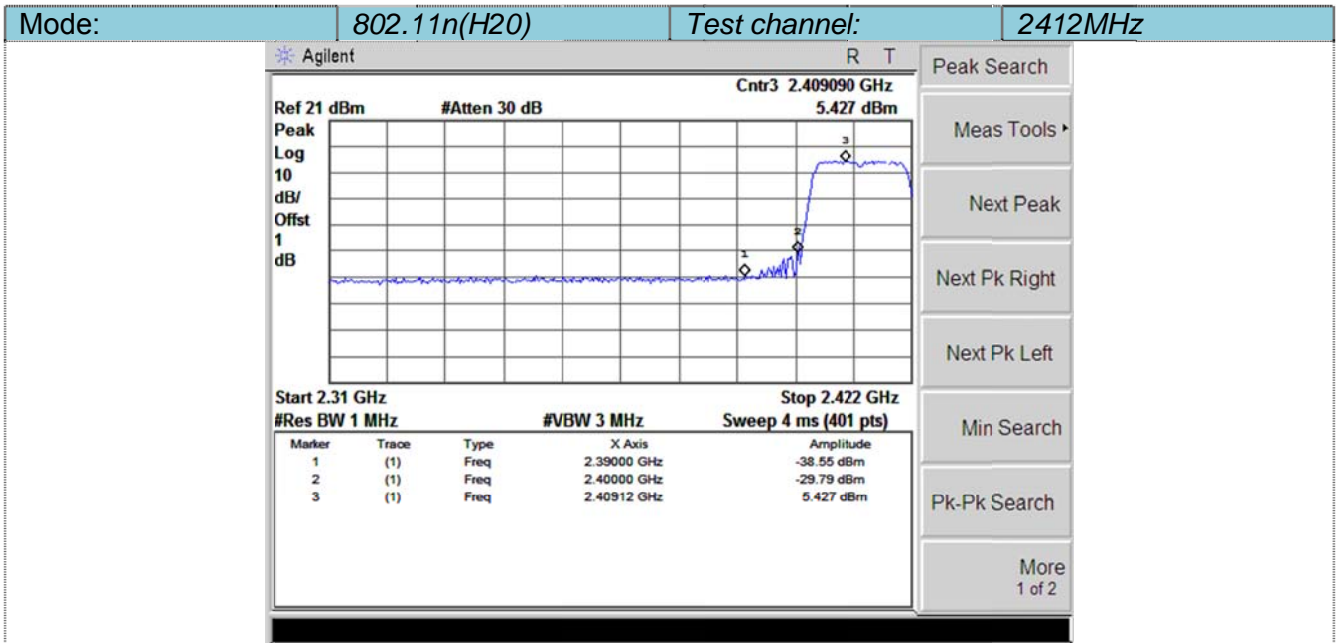

Peak

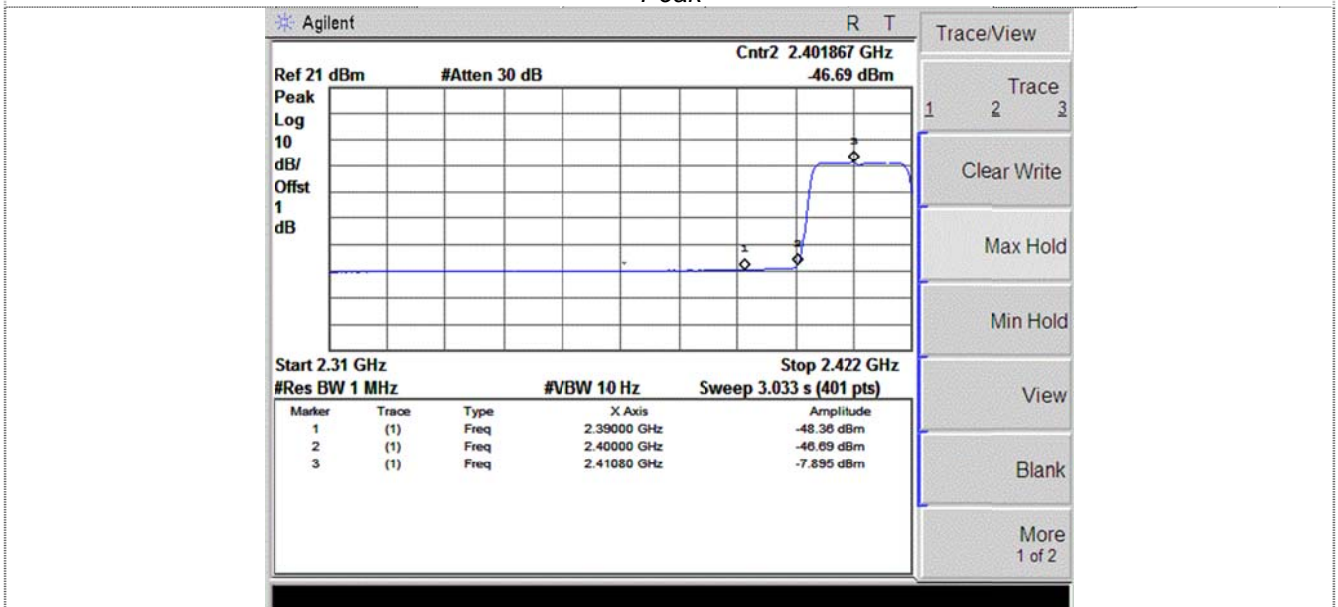

Average

| Frequency (MHz) | Conducted Power (dBm) | Antenna Gain (dBi) | Ground Reflection Factor (dB) | Covert Radiated E Level at 3m (dBuV/m) | Detector | Limit (dBuV/m) | Result |
|-----------------|-----------------------|--------------------|-------------------------------|--|----------|----------------|--------|
| 2390.00 | -38.55 | 2.00 | 0.00 | 58.71 | Peak | 74.00 | Pass |
| 2409.12 | 5.42 | 2.00 | 0.00 | 102.68 | Peak | | Pass |
| 2390.00 | -48.36 | 2.00 | 0.00 | 48.90 | Average | 54.00 | Pass |
| 2410.80 | -7.89 | 2.00 | 0.00 | 89.37 | Average | | Pass |

Mode: 802.11n(H20) Test channel: 2462MHz

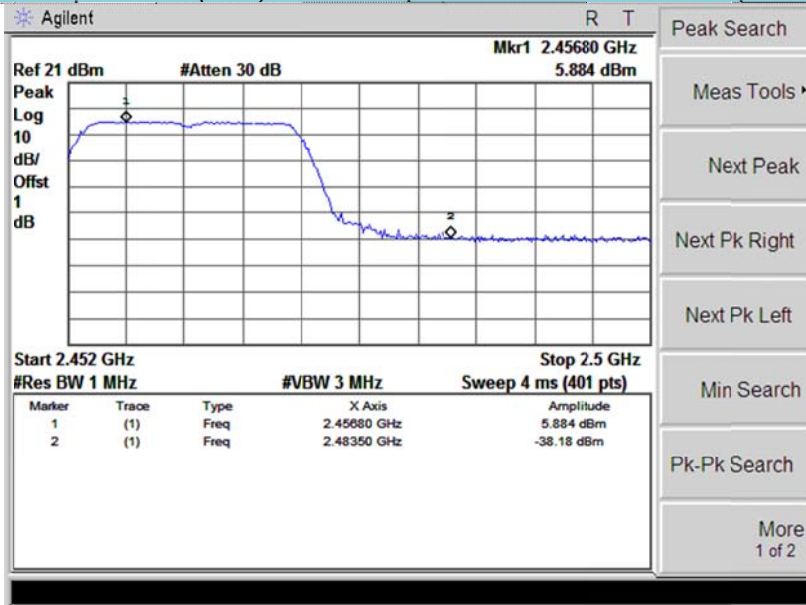

Peak

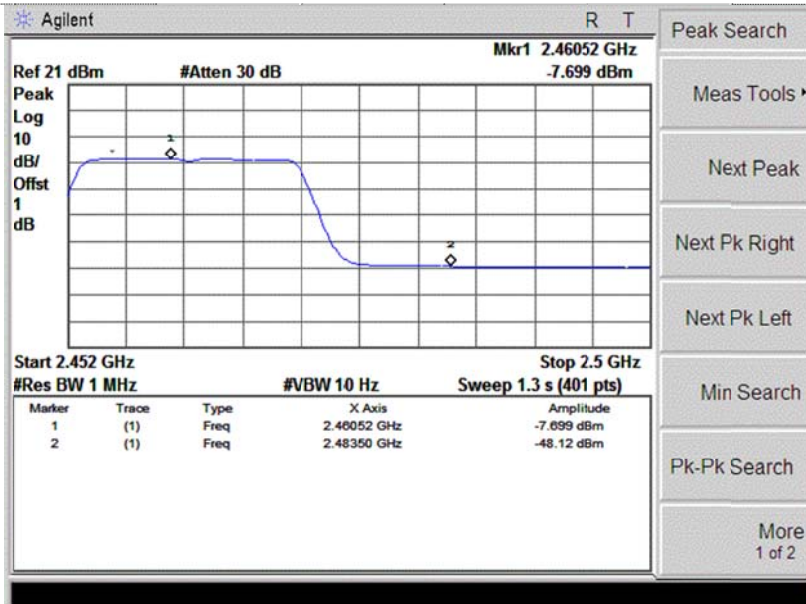

Average

| Frequency (MHz) | Conducted Power (dBm) | Antenna Gain (dBi) | Ground Reflection Factor (dB) | Covert Radiated E Level at 3m (dBuV/m) | Detector | Limit (dBuV/m) | Result |
|-----------------|-----------------------|--------------------|-------------------------------|--|----------|----------------|--------|
| 2456.80 | 5.88 | 2.00 | 0.00 | 103.14 | Peak | | Pass |
| 2483.50 | -38.18 | 2.00 | 0.00 | 59.08 | Peak | 74.00 | Pass |
| 2460.52 | -7.69 | 2.00 | 0.00 | 89.57 | Average | | Pass |
| 2483.50 | -48.12 | 2.00 | 0.00 | 49.14 | Average | 54.00 | Pass |

Mode: 802.11n(H40) Test channel: 2422MHz

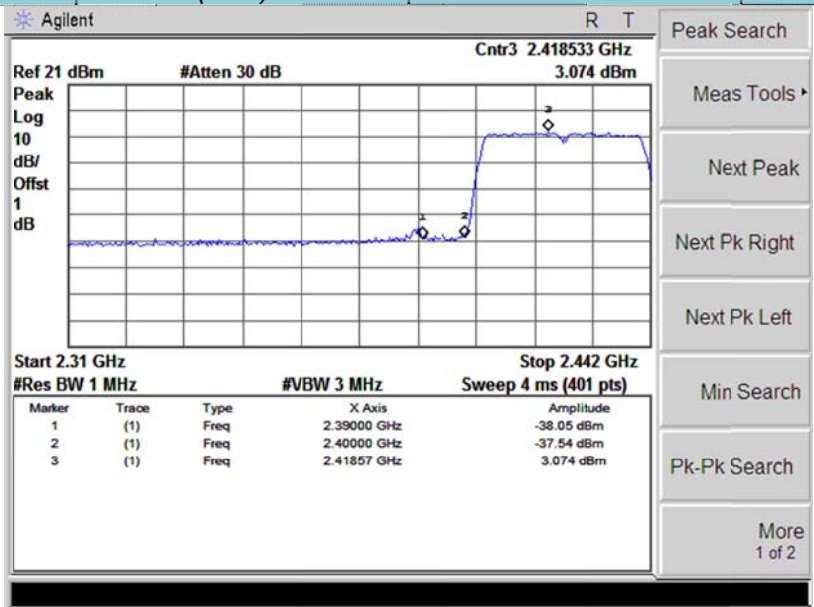

Peak

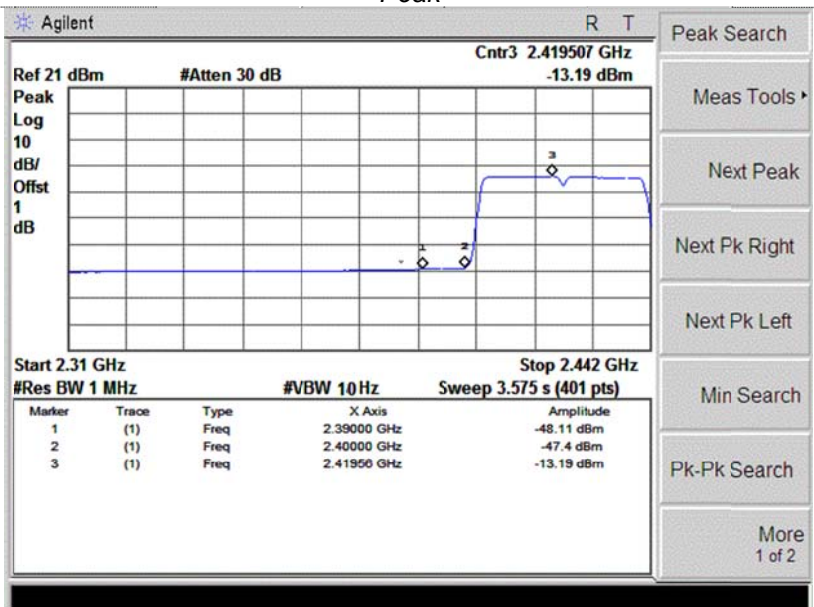

Average

| Frequency (MHz) | Conducted Power (dBm) | Antenna Gain (dBi) | Ground Reflection Factor (dB) | Covert Radiated E Level at 3m (dBuV/m) | Detector | Limit (dBuV/m) | Result |
|-----------------|-----------------------|--------------------|-------------------------------|--|----------|----------------|--------|
| 2390.00 | -38.05 | 2.00 | 0.00 | 59.21 | Peak | | Pass |
| 2418.57 | 3.07 | 2.00 | 0.00 | 100.33 | Peak | 74.00 | Pass |
| 2390.00 | -47.10 | 2.00 | 0.00 | 50.16 | Average | 54.00 | Pass |
| 2419.56 | -13.19 | 2.00 | 0.00 | 84.07 | Average | | Pass |

Mode: 802.11n(H40) Test channel: 2452MHz

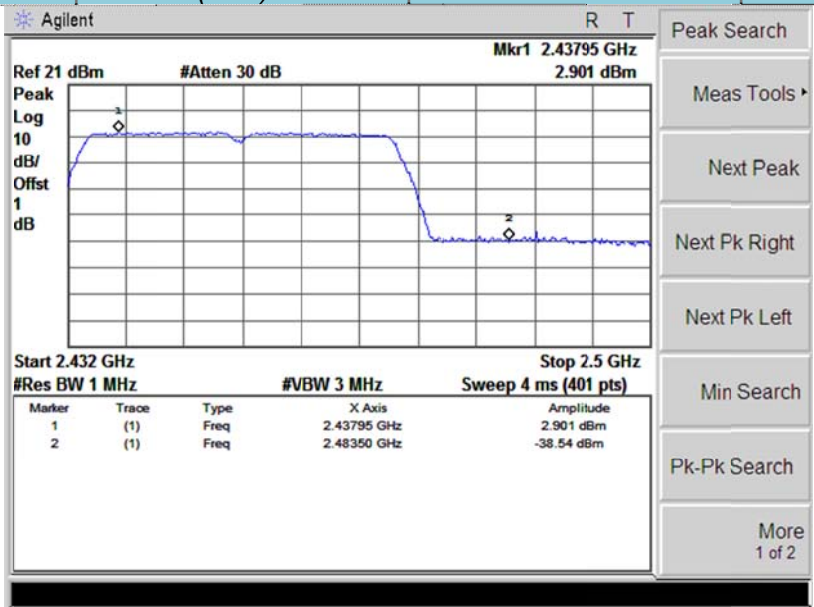

Peak

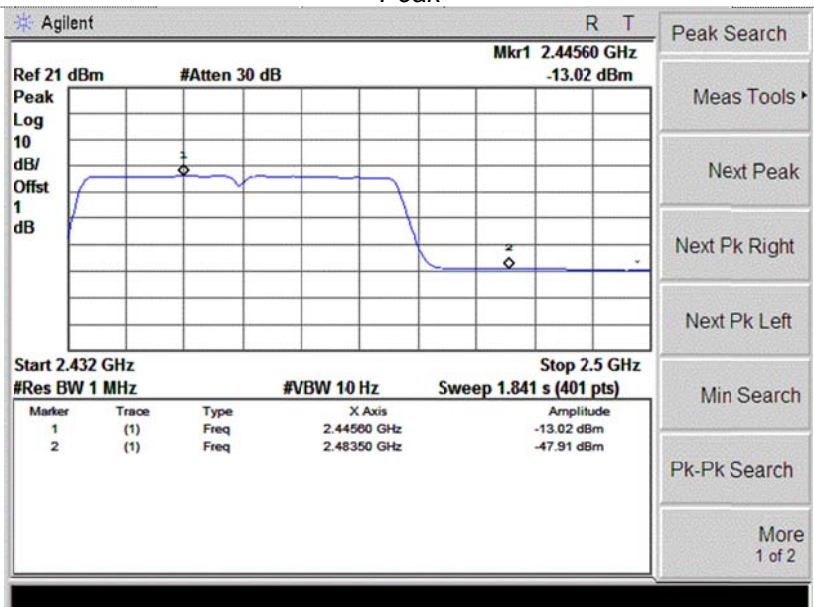

Average

| Frequency (MHz) | Conducted Power (dBm) | Antenna Gain (dBi) | Ground Reflection Factor (dB) | Covert Radiated E Level at 3m (dBuV/m) | Detector | Limit (dBuV/m) | Result |
|-----------------|-----------------------|--------------------|-------------------------------|--|----------|----------------|--------|
| 2437.95 | 2.90 | 2.00 | 0.00 | 100.16 | Peak | | Pass |
| 2483.50 | -38.54 | 2.00 | 0.00 | 58.72 | Peak | 74.00 | Pass |
| 2445.60 | -13.02 | 2.00 | 0.00 | 84.24 | Average | | Pass |
| 2483.50 | -47.91 | 2.00 | 0.00 | 49.35 | Average | 54.00 | Pass |

4.7. Spurious Emission (conducted)

LIMIT

FCC CFR Title 47 Part 15 Subpart C Section 15.247 (d):

In any 100 kHz bandwidth outside the frequency band in which the spread spectrum intentional radiator is operating, the radio frequency power that is produced by the intentional radiator shall be at least 20 dB below that in the 100 kHz bandwidth within the band that contains the highest level of the desired power, based on either an RF conducted or a radiated measurement.

TEST CONFIGURATION



TEST PROCEDURE

1. The transmitter output was connected to the spectrum analyzer through an attenuator.
2. The bandwidth of the fundamental frequency was measured by spectrum analyzer with RBW=100 KHz and VBW=300KHz, scan up through 10th harmonic

TEST RESULTS

Test plot as follows:

802.11b

Test channel

2412MHz

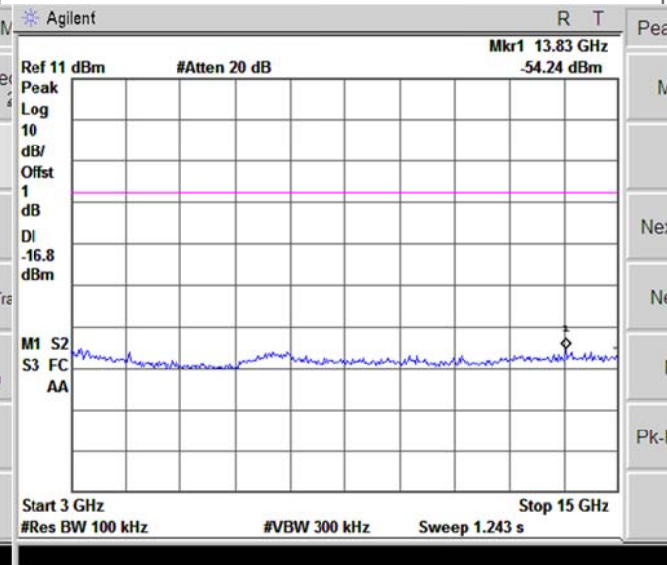
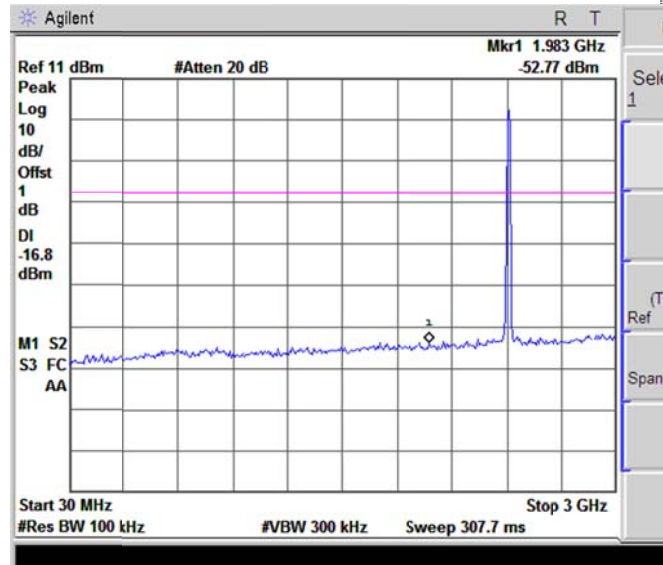

30MHz~3GHz

3GHz~15GHz

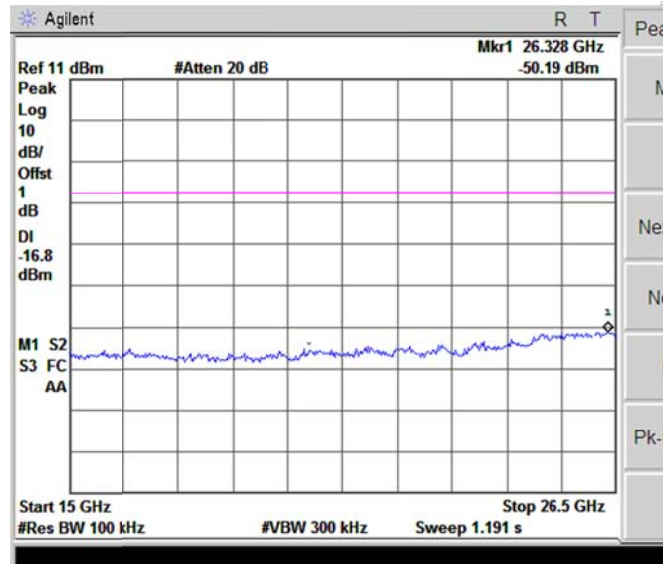

15GHz~26.5GHz

Test channel

2437MHz

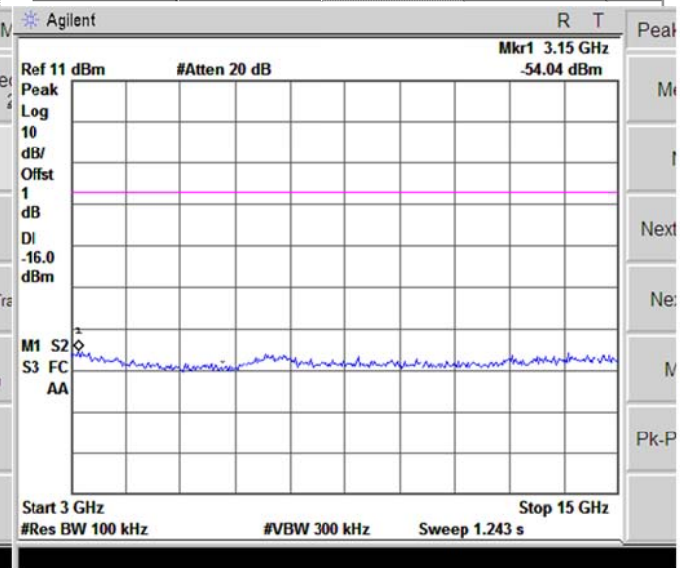
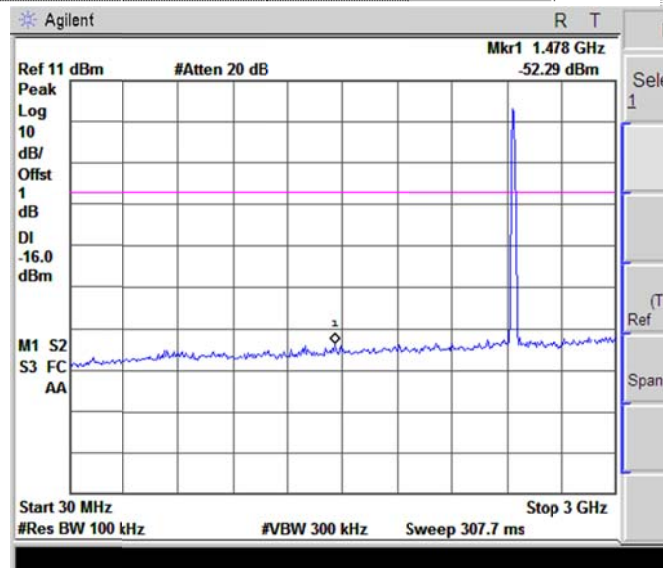

30MHz~3GHz

3GHz~15GHz

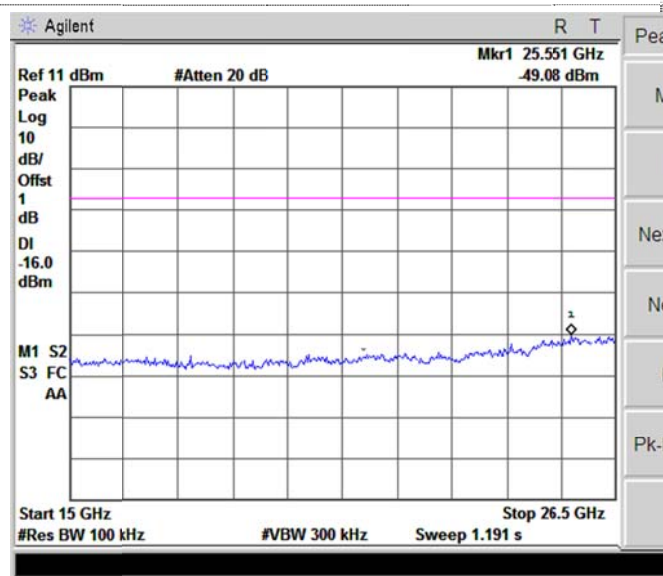

15GHz~26.5GHz

Test channel

2462MHz

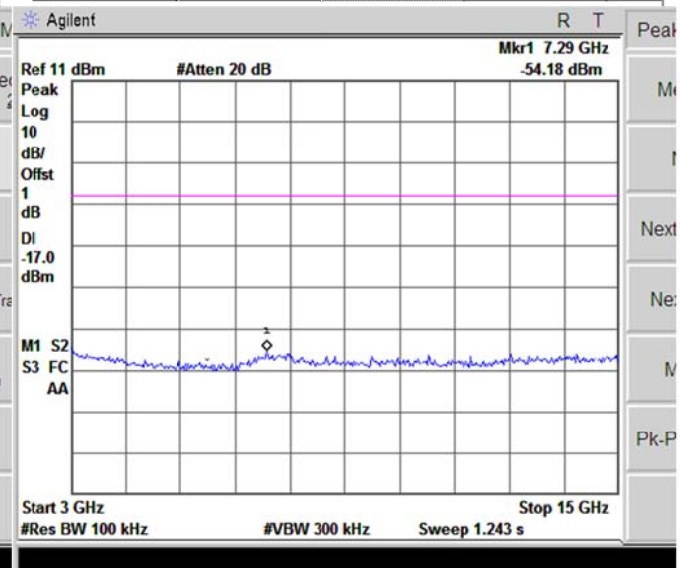
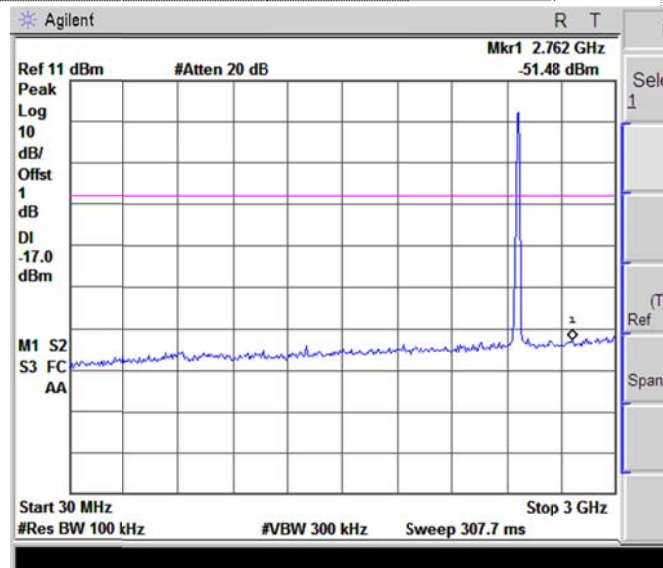

30MHz~3GHz

3GHz~15GHz

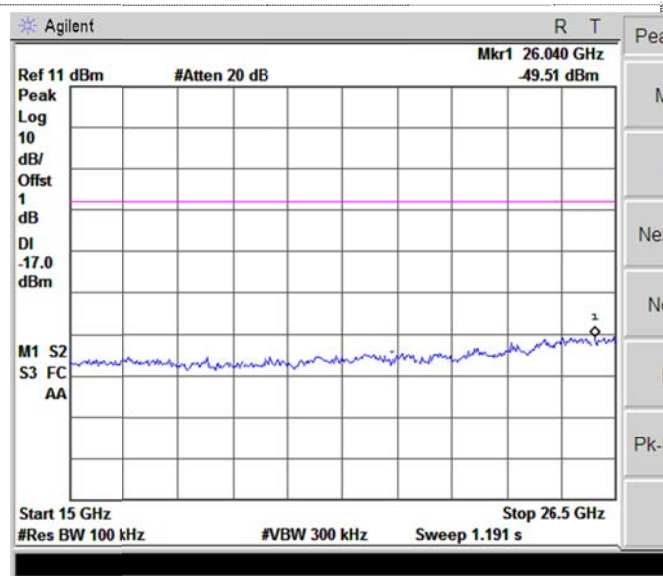

15GHz~26.5GHz

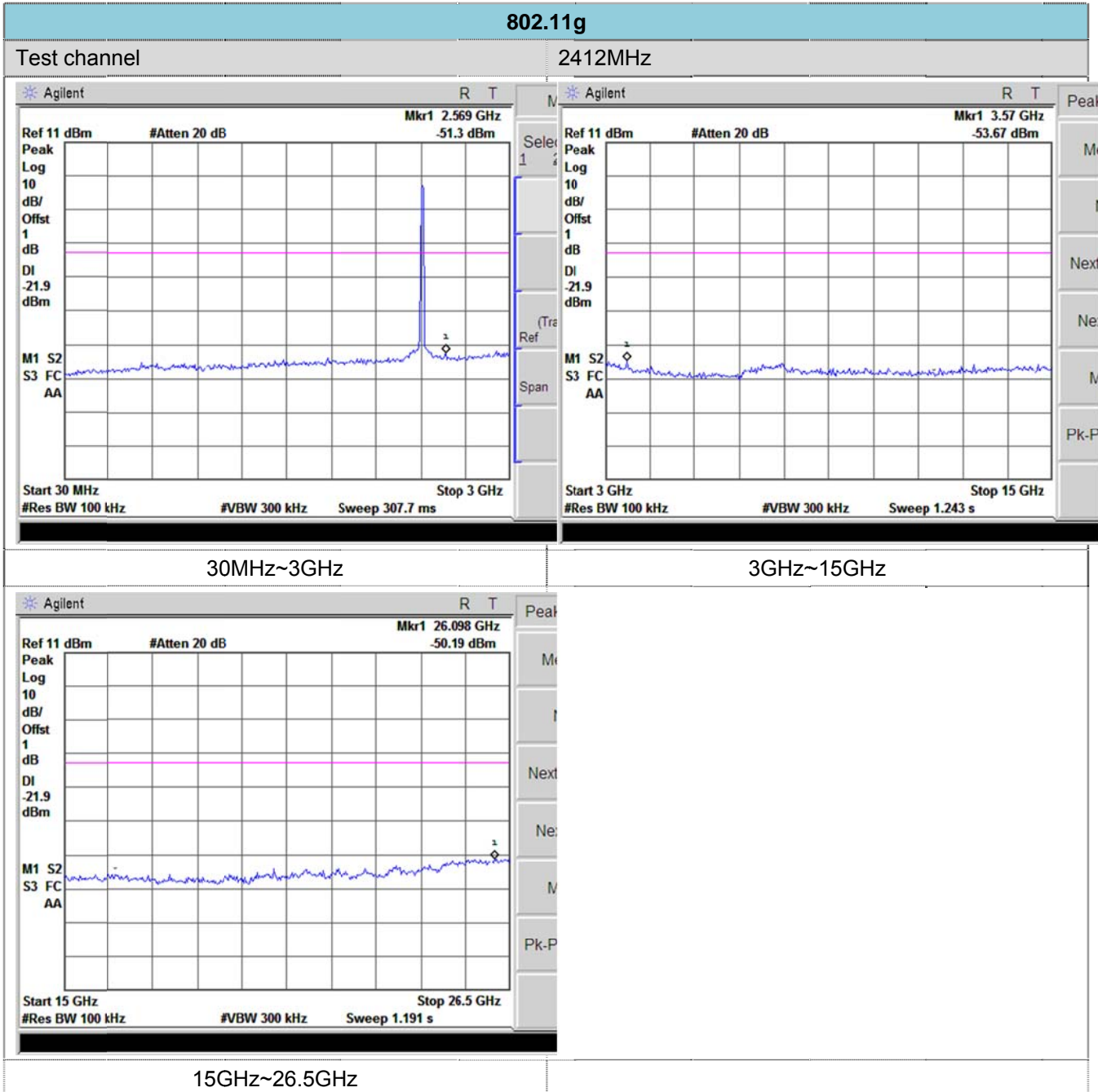

Test channel

2437MHz

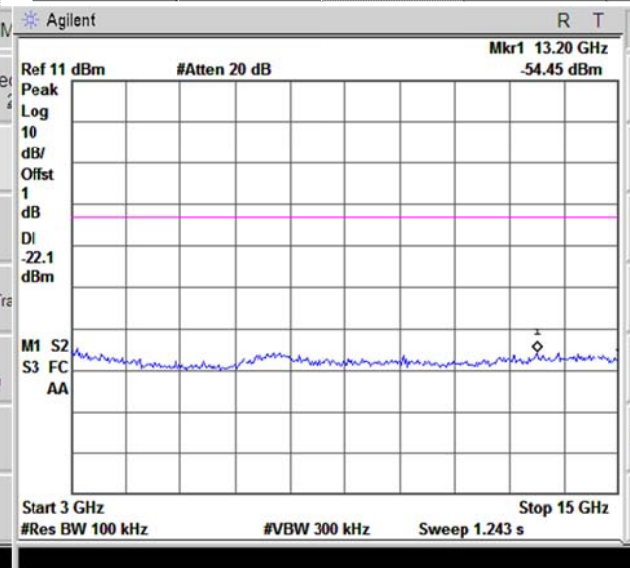
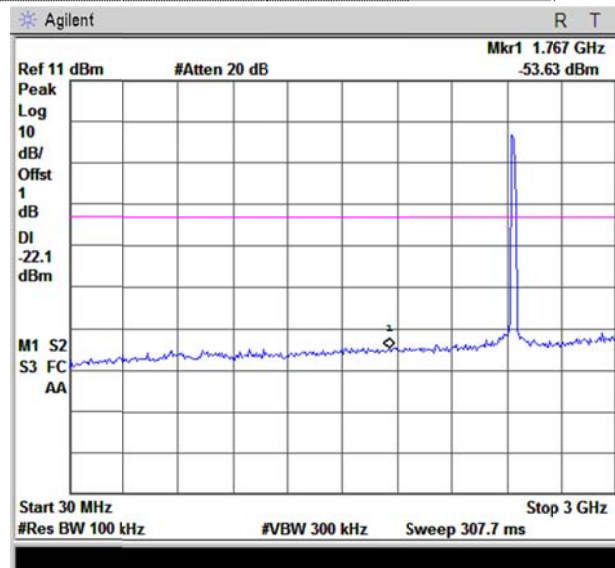

30MHz~3GHz

3GHz~15GHz

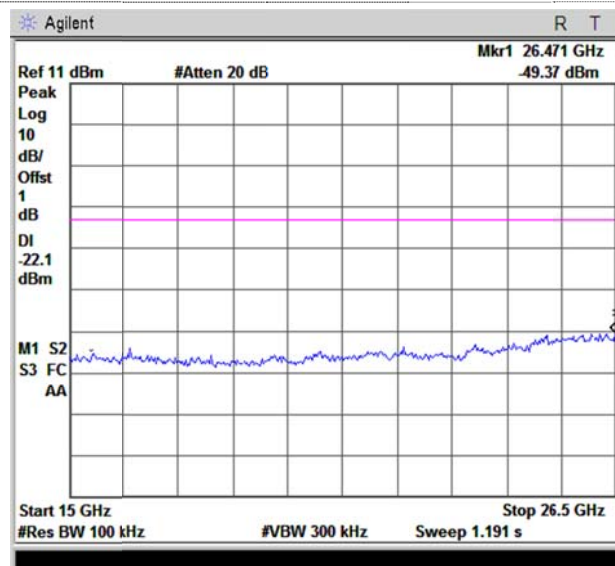

15GHz~26.5GHz

Test channel

2462MHz

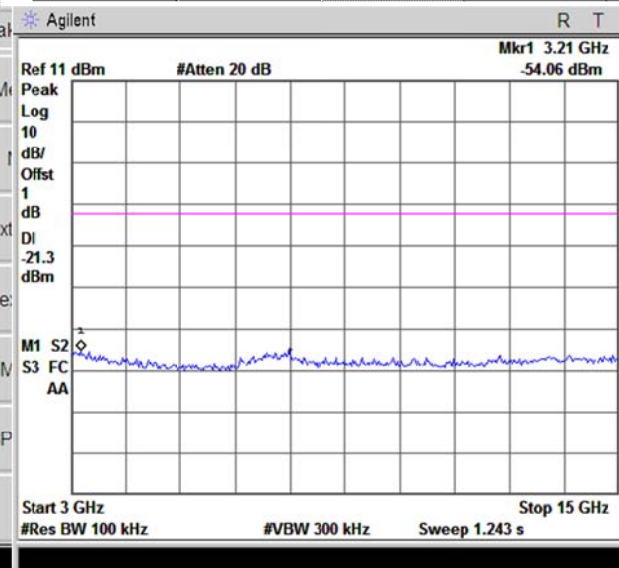
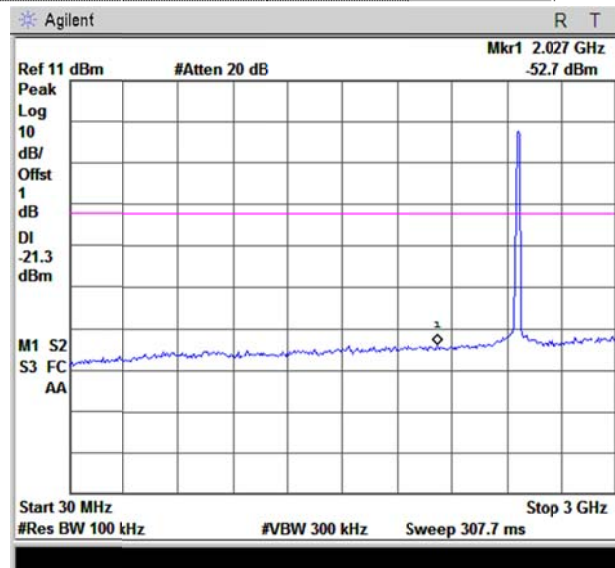

30MHz~3GHz

3GHz~15GHz

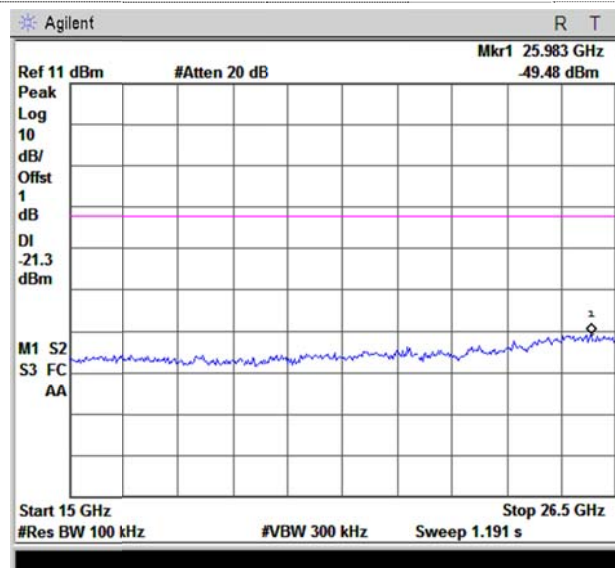

15GHz~26.5GHz

802.11n(H20)

Test channel

2412MHz

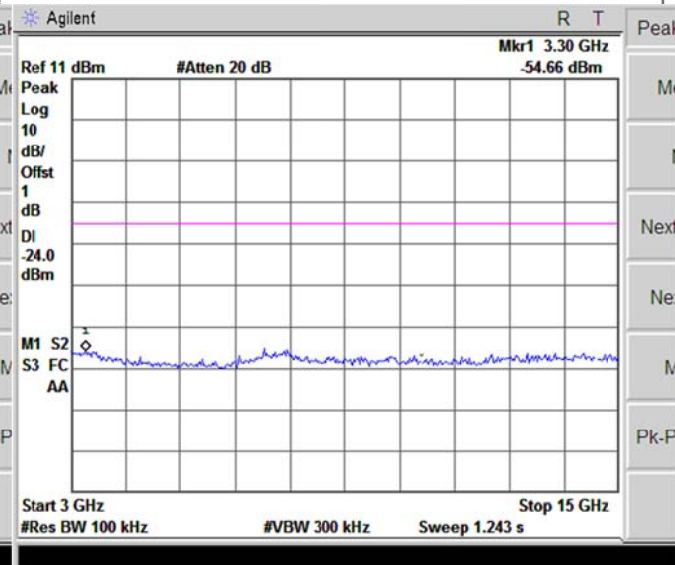
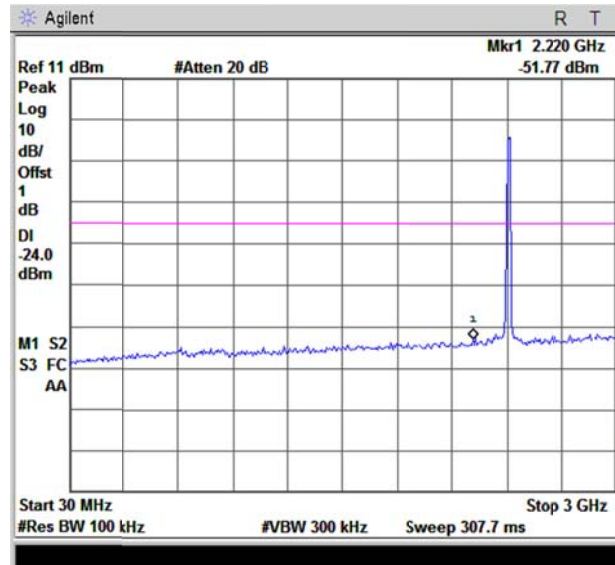

30MHz~3GHz

3GHz~15GHz

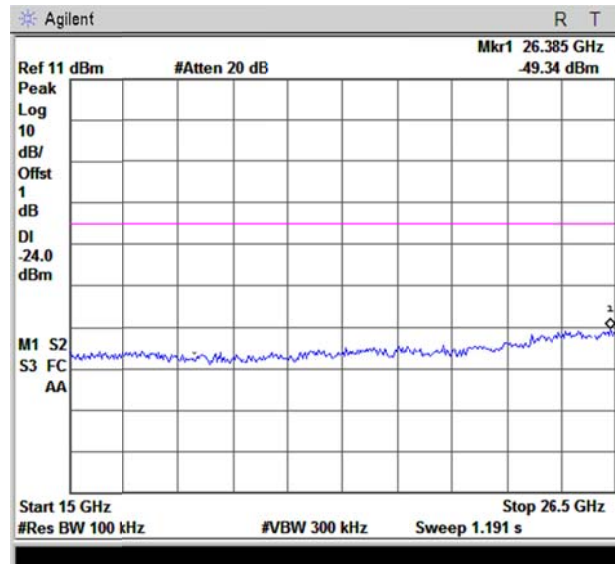

15GHz~26.5GHz

Test channel

2437MHz

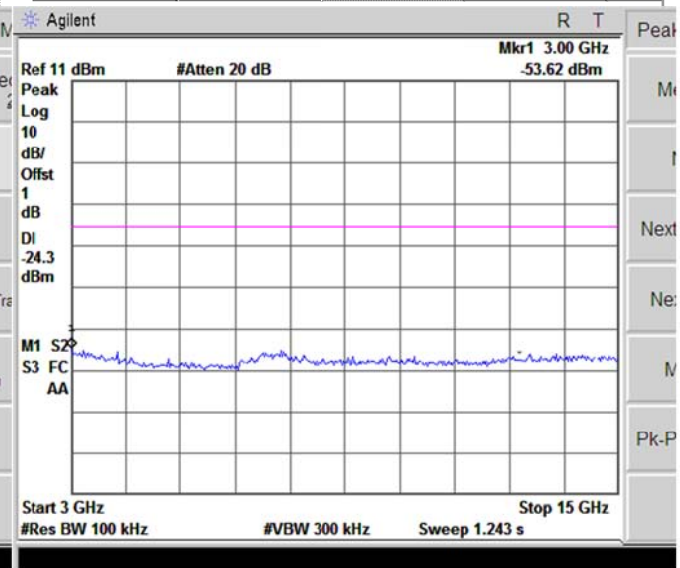
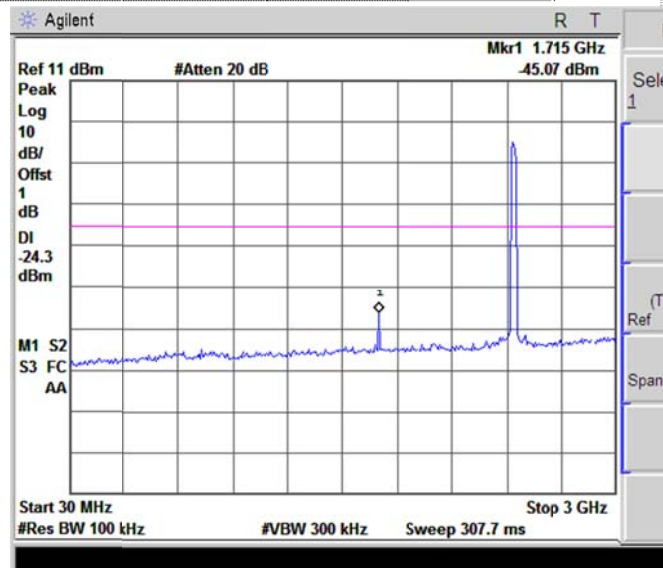

30MHz~3GHz

3GHz~15GHz

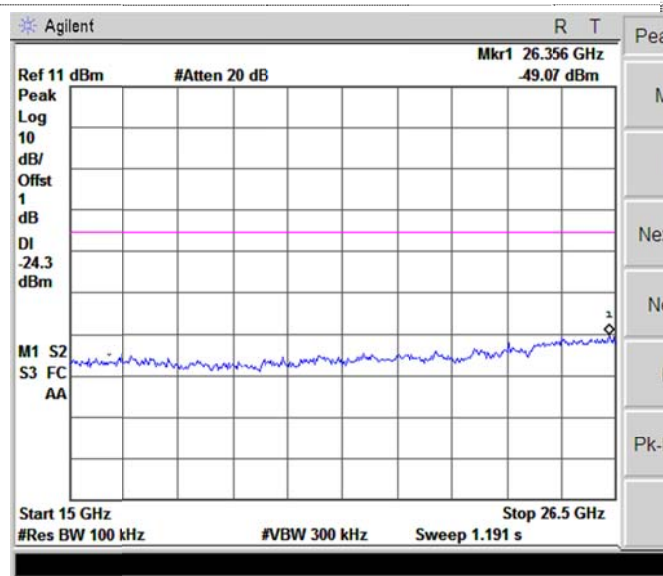

15GHz~26.5GHz

Test channel

2462MHz

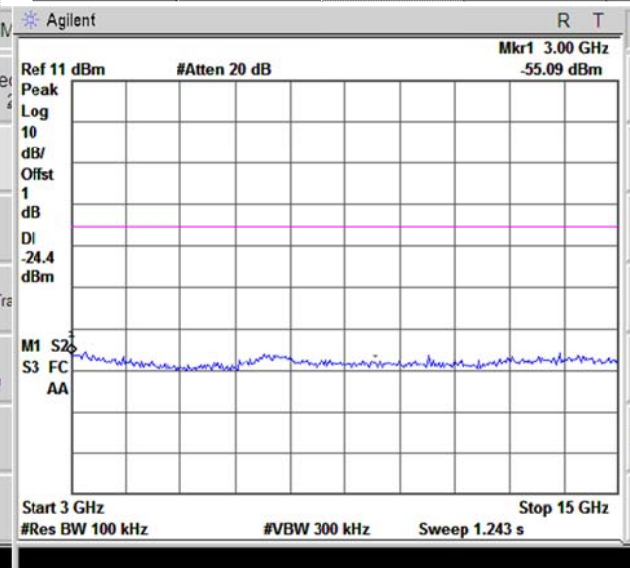
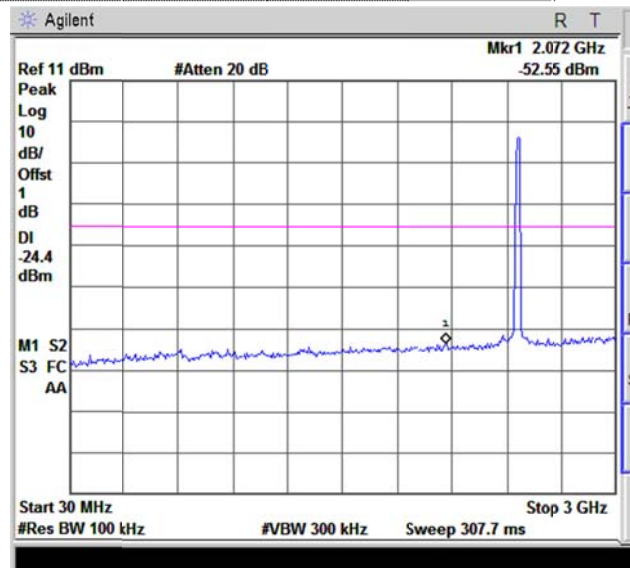

30MHz~3GHz

3GHz~15GHz

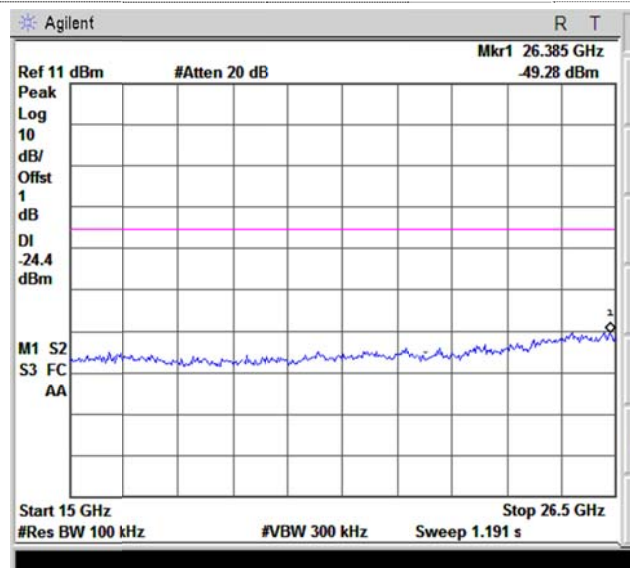

15GHz~26.5GHz

802.11n(H40)

Test channel

2422MHz

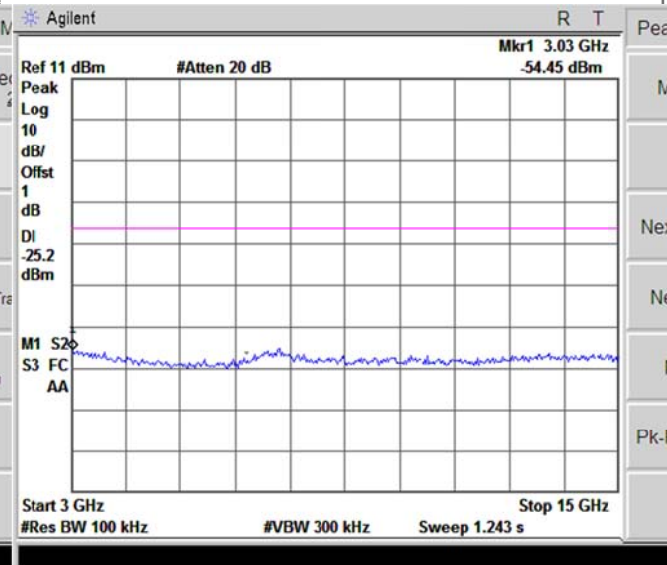
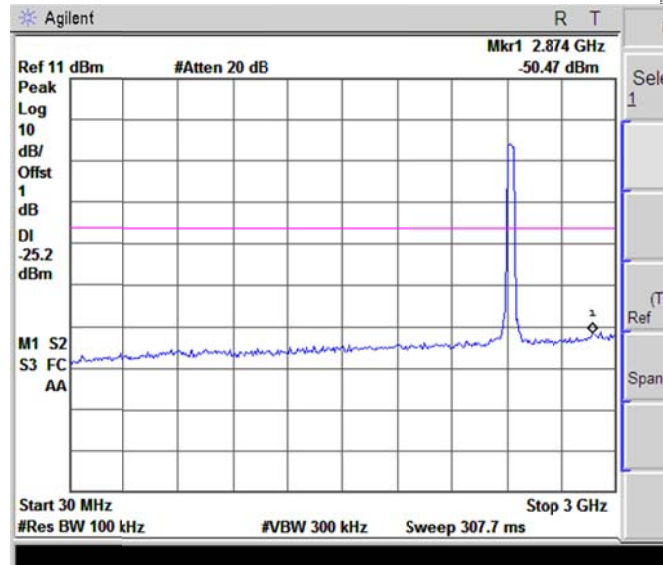

30MHz~3GHz

3GHz~15GHz

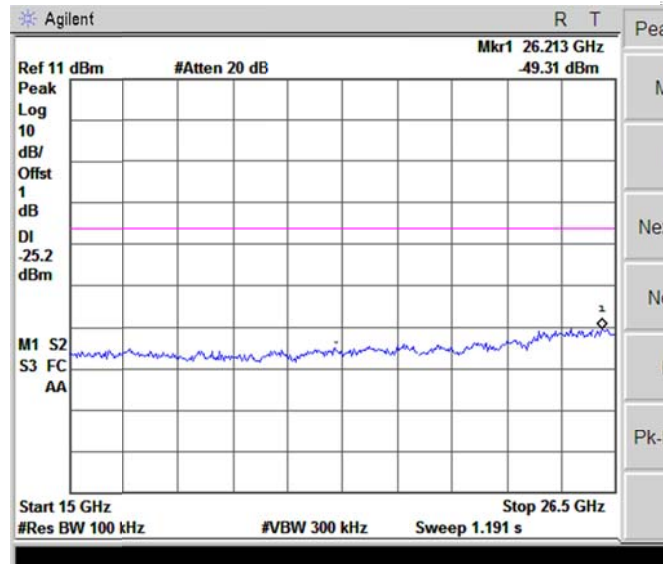

15GHz~26.5GHz

Test channel

2437MHz

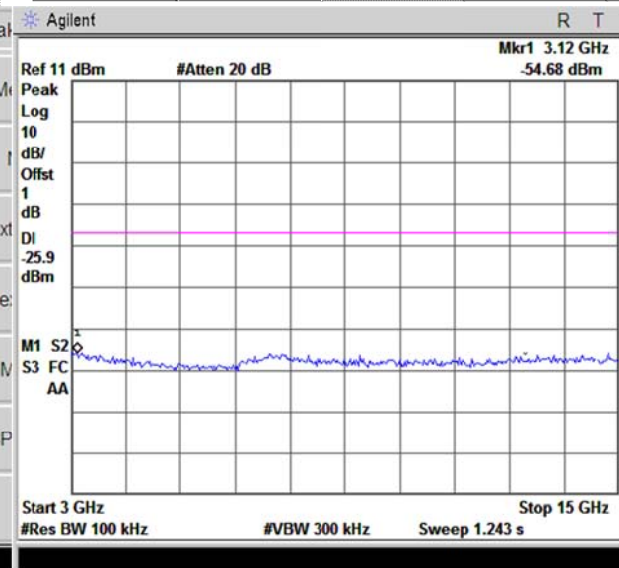
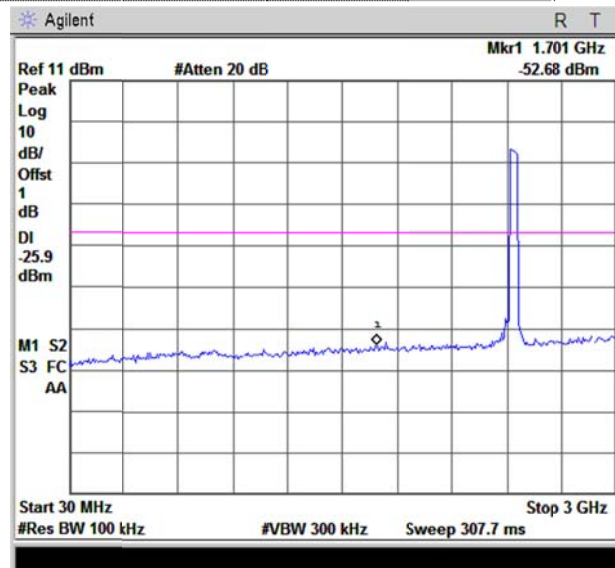

30MHz~3GHz

3GHz~15GHz

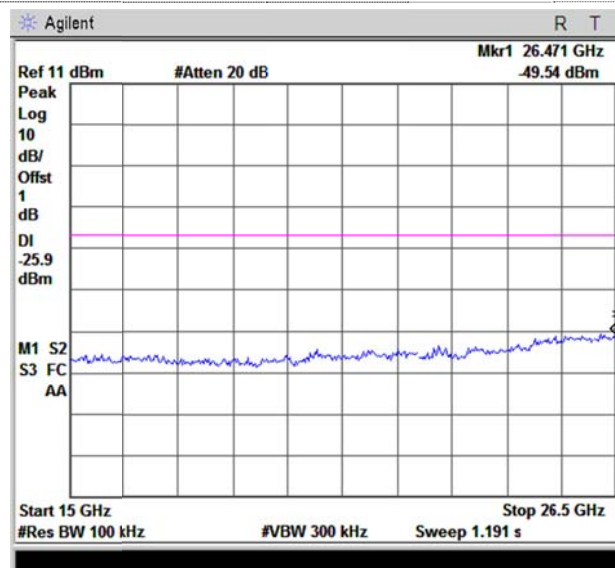

15GHz~26.5GHz

Test channel

2452MHz

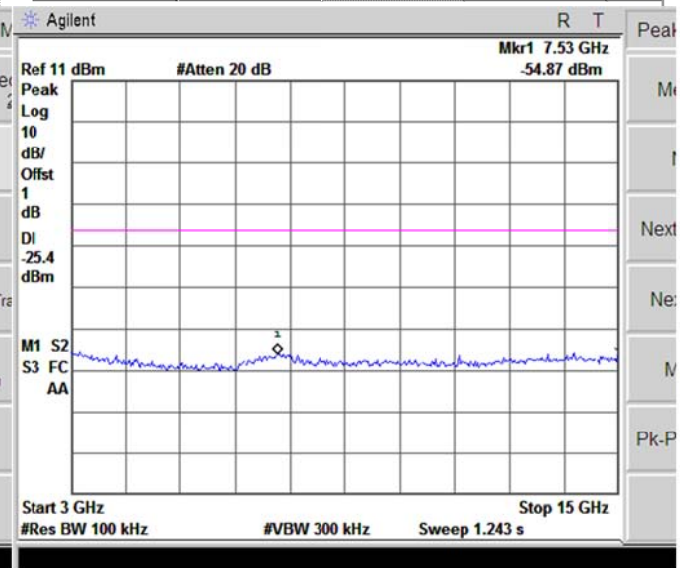
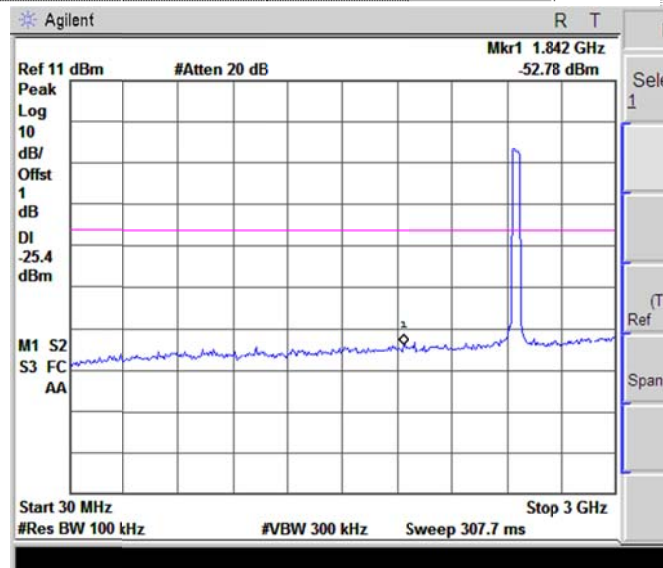

30MHz~3GHz

3GHz~15GHz

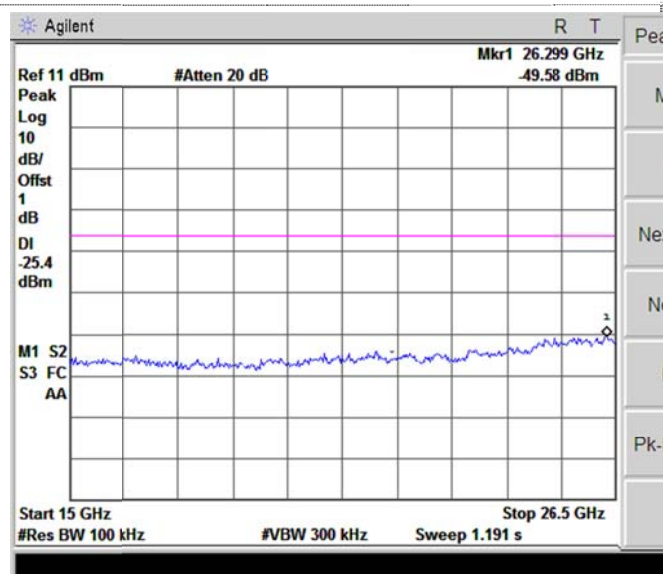

15GHz~26.5GHz

4.8. Spurious Emission (radiated)

LIMIT

FCC CFR Title 47 Part 15 Subpart C Section 15.209

| Frequency | Limit (dBuV/m @3m) | Value |
|---------------|--------------------|------------|
| 30MHz-88MHz | 40.00 | Quasi-peak |
| 88MHz-216MHz | 43.50 | Quasi-peak |
| 216MHz-960MHz | 46.00 | Quasi-peak |
| 960MHz-1GHz | 54.00 | Quasi-peak |
| Above 1GHz | 54.00 | Average |
| | 74.00 | Peak |

TEST CONFIGURATION

- Below 1GHz

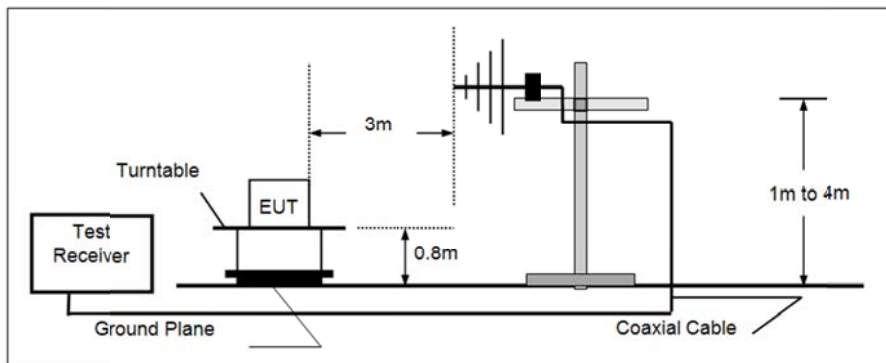

- Above 1GHz

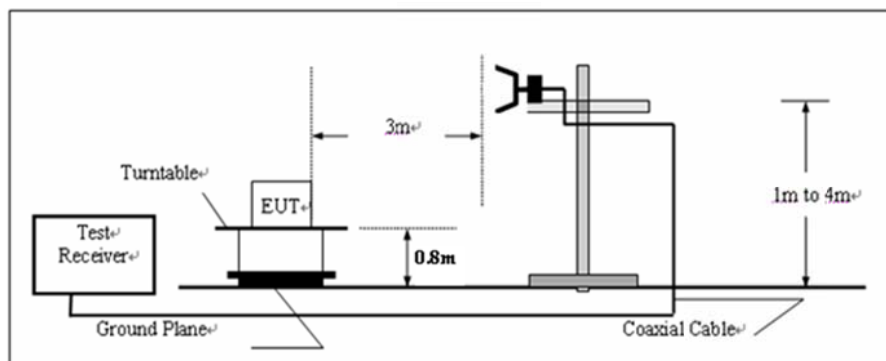

TEST PROCEDURE

1. The EUT was setup according to ANSI C63.4: 2009 and tested according to ANSI C63.10:2009 for compliance to FCC 47CFR 15.247 requirements.
2. The EUT is placed on a turn table which is 0.8 meter above ground. The turn table is rotated 360 degrees to determine the position of the maximum emission level.
3. The EUT was positioned such that the distance from antenna to the EUT was 3 meters.
4. The antenna is scanned from 1 meter to 4 meters to find out the maximum emission level. This is repeated for both horizontal and vertical polarization of the antenna. In order to find the maximum emission, all of the interface cables were manipulated according to ANSI C63.4:2009 on radiated measurement.
5. The resolution bandwidth below 1GHz setting on the field strength meter is 120 kHz and above 1GHz is 1MHz.
6. For Frequencies below 1 GHz, RBW= 120 kHz, testing was performed with CISPR16 compliant test receiver with QP detector. Above 1 GHz tests were performed using a spectrum analyser using the following settings:
Peak RBW=VBW= 1MHz , Peak detector
Average RBW 1MHz , VBW=10Hz, Peak detector
7. These settings as per ANSI C63.10

TEST RESULTS

Noted:

Have pre-scan all modulation mode, found the 802.11b mode which it was worst case, so only the worst case's data on the test report.

For 9KHz to 30MHz

| Frequency (MHz) | Level (dBuV/m)@3m | Limit Line (dBuV/m)@3m | Margin (dB) | Detector | Result |
|-----------------|-------------------|------------------------|-------------|----------|--------|
| 13.45 | 42.37 | 69.54 | -27.17 | QP | PASS |
| 24.63 | 40.85 | 69.54 | -28.69 | QP | PASS |

Measurement data:

■ Below 1GHz

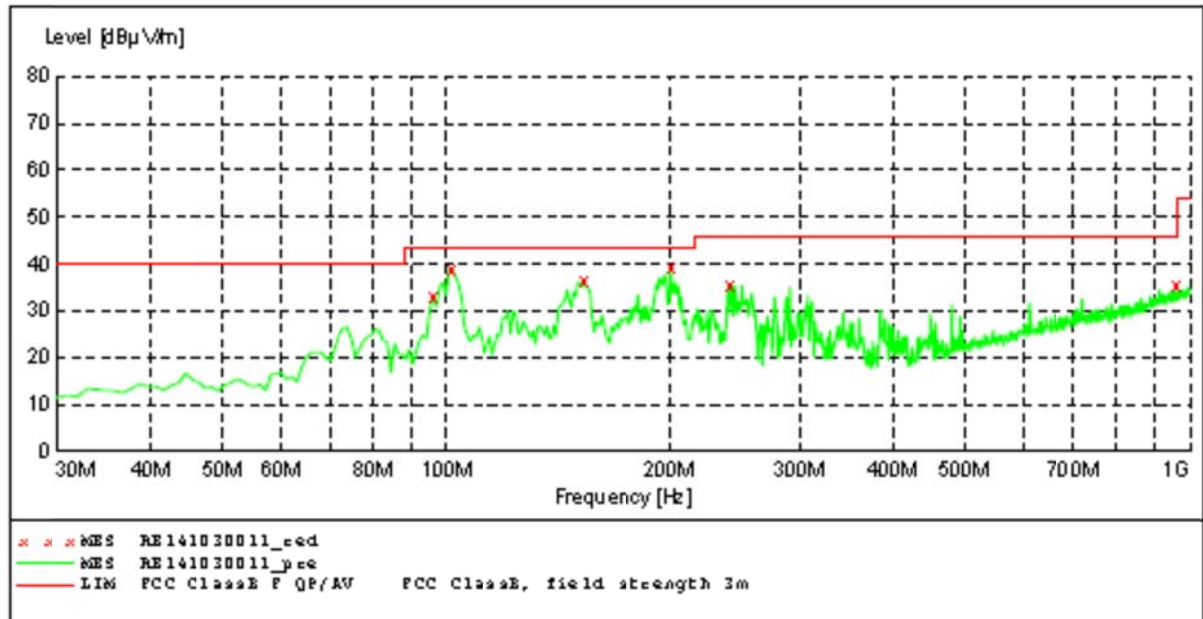

MEASUREMENT RESULT: "RE141030011_red"

10/30/2014 8:00PM

| Frequency MHz | Level dBµV/m | Transd dB | Limit dBµV/m | Margin dB | Det. | Height cm | Azimuth deg | Polarization |
|------------------|-----------------|--------------|-----------------|--------------|------|--------------|----------------|--------------|
| 95.960000 | 32.90 | -14.2 | 43.5 | 10.6 | QP | 300.0 | 303.00 | HORIZONTAL |
| 101.780000 | 39.10 | -13.8 | 43.5 | 4.4 | QP | 300.0 | 303.00 | HORIZONTAL |
| 153.190000 | 36.50 | -18.0 | 43.5 | 7.0 | QP | 100.0 | 139.00 | HORIZONTAL |
| 200.720000 | 39.50 | -14.5 | 43.5 | 4.0 | QP | 100.0 | 168.00 | HORIZONTAL |
| 241.460000 | 35.40 | -15.3 | 46.0 | 10.6 | QP | 100.0 | 139.00 | HORIZONTAL |
| 958.290000 | 35.30 | 3.5 | 46.0 | 10.7 | QP | 300.0 | 90.00 | HORIZONTAL |

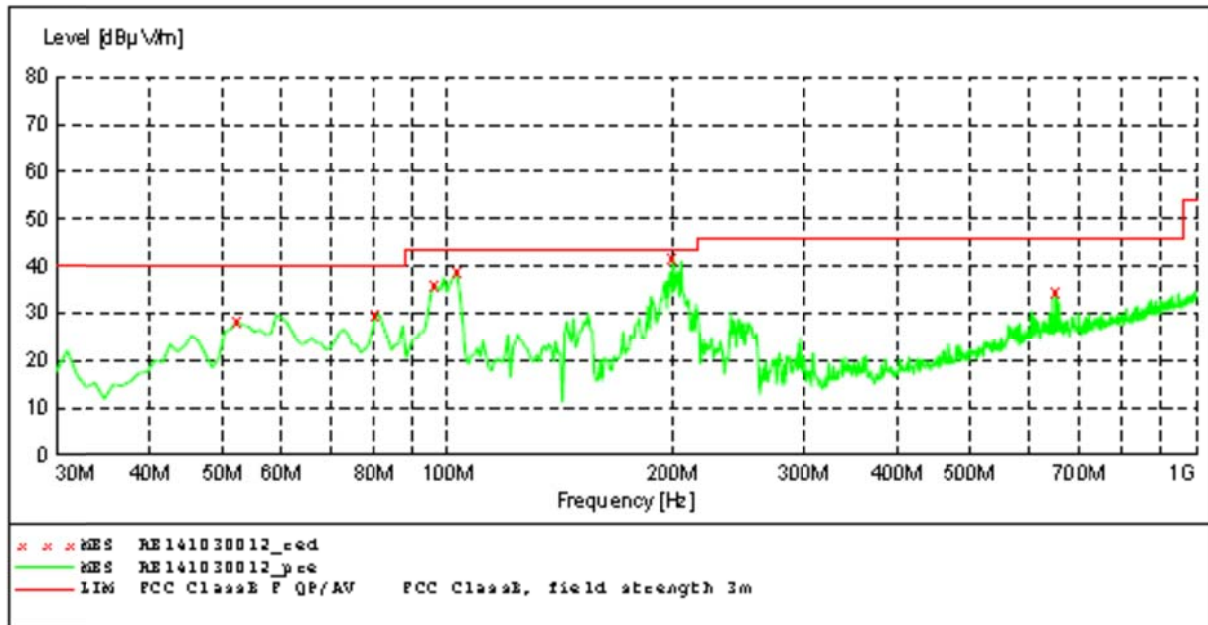

MEASUREMENT RESULT: "RE141030012_red"

10/30/2014 8:03PM

| Frequency MHz | Level dBµV/m | Transd dB | Limit dBµV/m | Margin dB | Det. | Height cm | Azimuth deg | Polarization |
|------------------|-----------------|--------------|-----------------|--------------|------|--------------|----------------|--------------|
| 52.310000 | 28.20 | -15.3 | 40.0 | 11.8 | QP | 100.0 | 360.00 | VERTICAL |
| 80.440000 | 29.60 | -19.0 | 40.0 | 10.4 | QP | 100.0 | 66.00 | VERTICAL |
| 95.960000 | 36.10 | -14.2 | 43.5 | 7.4 | QP | 100.0 | 300.00 | VERTICAL |
| 102.750000 | 38.70 | -13.9 | 43.5 | 4.8 | QP | 100.0 | 66.00 | VERTICAL |
| 200.720000 | 41.80 | -14.5 | 43.5 | 1.7 | QP | 100.0 | 125.00 | VERTICAL |
| 651.770000 | 34.70 | -2.3 | 46.0 | 11.3 | QP | 100.0 | 242.00 | VERTICAL |

Above 1GHz

| | |
|---------------|----|
| Test channel: | 01 |
|---------------|----|

Peak value:

| Frequency (MHz) | Read Level (dBuV) | Antenna Factor (dB/m) | Cable Loss (dB) | Preamp Factor (dB) | Level (dBuV/m) | Limit Line (dBuV/m) | Margin Limit (dB) | Polarization |
|-----------------|-------------------|-----------------------|-----------------|--------------------|----------------|---------------------|-------------------|--------------|
| 4824.00 | 38.40 | 31.44 | 5.87 | 35.46 | 40.25 | 74.00 | -33.75 | Vertical |
| 7236.00 | 35.50 | 36.38 | 7.08 | 35.32 | 43.64 | 74.00 | -30.36 | Vertical |
| 9648.00 | 36.22 | 38.01 | 9.01 | 35.72 | 47.52 | 74.00 | -26.48 | Vertical |
| 12060.00 | * | | | | | 74.00 | | Vertical |
| 14472.00 | * | | | | | 74.00 | | Vertical |
| 4824.00 | 38.51 | 31.44 | 5.87 | 35.46 | 40.36 | 74.00 | -33.64 | Horizontal |
| 7236.00 | 33.44 | 36.38 | 7.08 | 35.32 | 41.58 | 74.00 | -32.42 | Horizontal |
| 9648.00 | 35.45 | 38.01 | 9.01 | 35.72 | 46.75 | 74.00 | -27.25 | Horizontal |
| 12060.00 | * | | | | | 74.00 | | Horizontal |
| 14472.00 | * | | | | | 74.00 | | Horizontal |

Average value:

| Frequency (MHz) | Read Level (dBuV) | Antenna Factor (dB/m) | Cable Loss (dB) | Preamp Factor (dB) | Level (dBuV/m) | Limit Line (dBuV/m) | Margin Limit (dB) | Polarization |
|-----------------|-------------------|-----------------------|-----------------|--------------------|----------------|---------------------|-------------------|--------------|
| 4824.00 | 33.62 | 31.44 | 5.87 | 35.46 | 35.47 | 54.00 | -18.53 | Vertical |
| 7236.00 | 28.44 | 36.38 | 7.08 | 35.32 | 36.58 | 54.00 | -17.42 | Vertical |
| 9648.00 | 26.54 | 38.01 | 9.01 | 35.72 | 37.84 | 54.00 | -16.16 | Vertical |
| 12060.00 | * | | | | | 54.00 | | Vertical |
| 14472.00 | * | | | | | 54.00 | | Vertical |
| 4824.00 | 33.40 | 31.44 | 5.87 | 35.46 | 35.25 | 54.00 | -18.75 | Horizontal |
| 7236.00 | 28.24 | 36.38 | 7.08 | 35.32 | 36.38 | 54.00 | -17.62 | Horizontal |
| 9648.00 | 26.64 | 38.01 | 9.01 | 35.72 | 37.94 | 54.00 | -16.06 | Horizontal |
| 12060.00 | * | | | | | 54.00 | | Horizontal |
| 14472.00 | * | | | | | 54.00 | | Horizontal |

Remark:

1. Final Level = Receiver Read level + Antenna Factor + Cable Loss – Pre-amplifier Factor
2. “*”, means this data is too weak instrument of signal is unable to test.
3. The emission levels of other frequencies are very lower than the limit and not show in test report.

| | |
|---------------|----|
| Test channel: | 06 |
|---------------|----|

Peak value:

| Frequency (MHz) | Read Level (dBuV) | Antenna Factor (dB/m) | Cable Loss (dB) | Preamp Factor (dB) | Level (dBuV/m) | Limit Line (dBuV/m) | Over Limit (dB) | Polarization |
|-----------------|-------------------|-----------------------|-----------------|--------------------|----------------|---------------------|-----------------|--------------|
| 4874.00 | 38.95 | 30.88 | 5.70 | 35.27 | 40.26 | 74.00 | -33.74 | Vertical |
| 7311.00 | 35.92 | 35.82 | 6.91 | 35.13 | 43.52 | 74.00 | -30.48 | Vertical |
| 9748.00 | 37.08 | 37.45 | 8.84 | 35.53 | 47.84 | 74.00 | -26.16 | Vertical |
| 12185.00 | * | | | | | 74.00 | | Vertical |
| 14622.00 | * | | | | | 74.00 | | Vertical |
| 4874.00 | 39.34 | 30.88 | 5.70 | 35.27 | 40.65 | 74.00 | -33.35 | Horizontal |
| 7311.00 | 34.04 | 35.82 | 6.91 | 35.13 | 41.64 | 74.00 | -32.36 | Horizontal |
| 9748.00 | 35.13 | 37.45 | 8.84 | 35.53 | 45.89 | 74.00 | -28.11 | Horizontal |
| 12185.00 | * | | | | | 74.00 | | Horizontal |
| 14622.00 | * | | | | | 74.00 | | Horizontal |

Average value:

| Frequency (MHz) | Read Level (dBuV) | Antenna Factor (dB/m) | Cable Loss (dB) | Preamp Factor (dB) | Level (dBuV/m) | Limit Line (dBuV/m) | Over Limit (dB) | Polarization |
|-----------------|-------------------|-----------------------|-----------------|--------------------|----------------|---------------------|-----------------|--------------|
| 4874.00 | 34.37 | 30.88 | 5.70 | 35.27 | 35.68 | 54.00 | -18.32 | Vertical |
| 7311.00 | 29.15 | 35.82 | 6.91 | 35.13 | 36.75 | 54.00 | -17.25 | Vertical |
| 9748.00 | 27.73 | 37.45 | 8.84 | 35.53 | 38.49 | 54.00 | -15.51 | Vertical |
| 12185.00 | * | | | | | 54.00 | | Vertical |
| 14622.00 | * | | | | | 54.00 | | Vertical |
| 4874.00 | 34.33 | 30.88 | 5.70 | 35.27 | 35.64 | 54.00 | -18.36 | Horizontal |
| 7311.00 | 28.22 | 35.82 | 6.91 | 35.13 | 35.82 | 54.00 | -18.18 | Horizontal |
| 9748.00 | 26.93 | 37.45 | 8.84 | 35.53 | 37.69 | 54.00 | -16.31 | Horizontal |
| 12185.00 | * | | | | | 54.00 | | Horizontal |
| 14622.00 | * | | | | | 54.00 | | Horizontal |

Remark:

1. Final Level = Receiver Read level + Antenna Factor + Cable Loss – Pre-amplifier Factor
2. “*”, means this data is too weak instrument of signal is unable to test.
3. The emission levels of other frequencies are very lower than the limit and not show in test report.

| | |
|---------------|----|
| Test channel: | 11 |
|---------------|----|

Peak value:

| Frequency (MHz) | Read Level (dBuV) | Antenna Factor (dB/m) | Cable Loss (dB) | Preamp Factor (dB) | Level (dBuV/m) | Limit Line (dBuV/m) | Over Limit (dB) | Polarization |
|-----------------|-------------------|-----------------------|-----------------|--------------------|----------------|---------------------|-----------------|--------------|
| 4924.00 | 39.66 | 30.98 | 5.73 | 35.32 | 41.05 | 74.00 | -32.95 | Vertical |
| 7386.00 | 34.57 | 35.92 | 6.94 | 35.18 | 42.25 | 74.00 | -31.75 | Vertical |
| 9848.00 | 35.91 | 37.55 | 8.87 | 35.58 | 46.75 | 74.00 | -27.25 | Vertical |
| 12310.00 | * | | | | | 74.00 | | Vertical |
| 14772.00 | * | | | | | 74.00 | | Vertical |
| 4924.00 | 38.85 | 30.98 | 5.73 | 35.32 | 40.24 | 74.00 | -33.76 | Horizontal |
| 7386.00 | 35.40 | 35.92 | 6.94 | 35.18 | 43.08 | 74.00 | -30.92 | Horizontal |
| 9848.00 | 36.01 | 37.55 | 8.87 | 35.58 | 46.85 | 74.00 | -27.15 | Horizontal |
| 12310.00 | * | | | | | 74.00 | | Horizontal |
| 14772.00 | * | | | | | 74.00 | | Horizontal |

Average value:

| Frequency (MHz) | Read Level (dBuV) | Antenna Factor (dB/m) | Cable Loss (dB) | Preamp Factor (dB) | Level (dBuV/m) | Limit Line (dBuV/m) | Over Limit (dB) | Polarization |
|-----------------|-------------------|-----------------------|-----------------|--------------------|----------------|---------------------|-----------------|--------------|
| 4924.00 | 34.46 | 30.98 | 5.73 | 35.32 | 35.85 | 54.00 | -18.15 | Vertical |
| 7386.00 | 29.06 | 35.92 | 6.94 | 35.18 | 36.74 | 54.00 | -17.26 | Vertical |
| 9848.00 | 27.02 | 37.55 | 8.87 | 35.58 | 37.86 | 54.00 | -16.14 | Vertical |
| 12310.00 | * | | | | | 54.00 | | Vertical |
| 14772.00 | * | | | | | 54.00 | | Vertical |
| 4924.00 | 34.35 | 30.98 | 5.73 | 35.32 | 35.74 | 54.00 | -18.26 | Horizontal |
| 7386.00 | 29.17 | 35.92 | 6.94 | 35.18 | 36.85 | 54.00 | -17.15 | Horizontal |
| 9848.00 | 28.10 | 37.55 | 8.87 | 35.58 | 38.94 | 54.00 | -15.06 | Horizontal |
| 12310.00 | * | | | | | 54.00 | | Horizontal |
| 14772.00 | * | | | | | 54.00 | | Horizontal |

Remark:

1. Final Level = Receiver Read level + Antenna Factor + Cable Loss – Pre-amplifier Factor
2. “*”, means this data is too weak instrument of signal is unable to test.
3. The emission levels of other frequencies are very lower than the limit and not show in test report.

5. Test Setup Photos of the EUT

Radiated Emission (30MHz-1GHz)



Radiated Emission (above 1GHz)

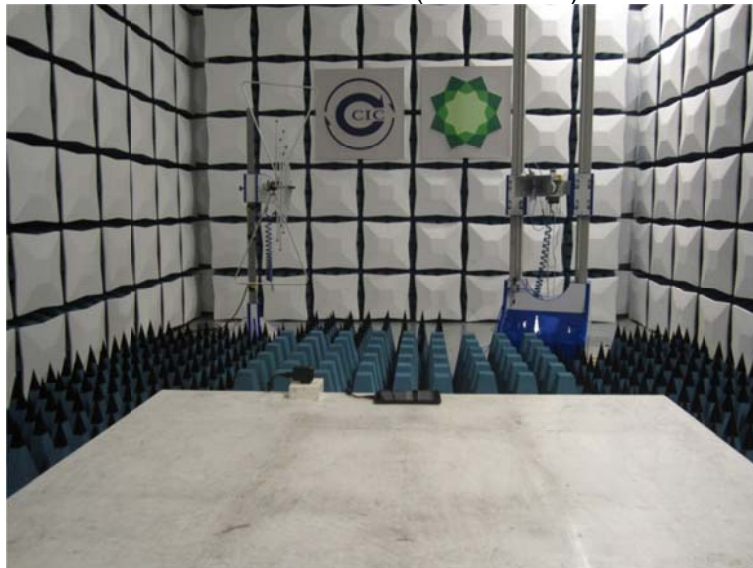

Conducted Emission (AC Mains)



6. External and Internal Photos of the EUT External photos of the EUT







Internal photos of the EUT



WIFI/BT Antenna

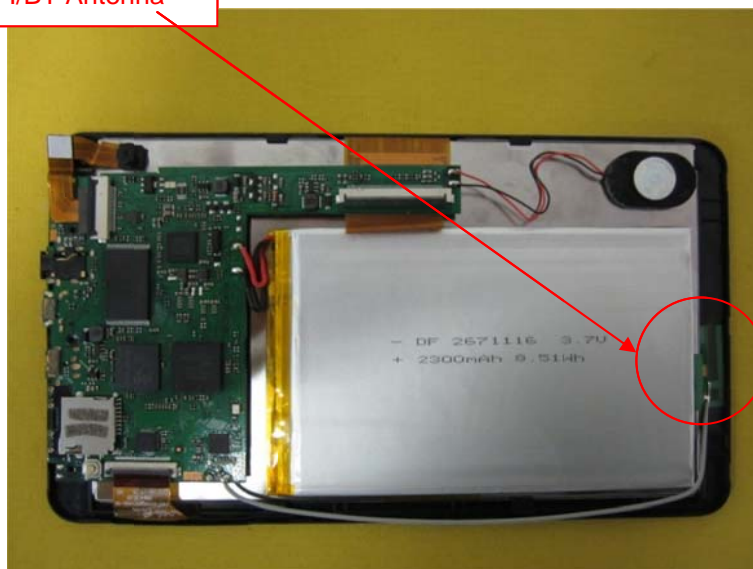

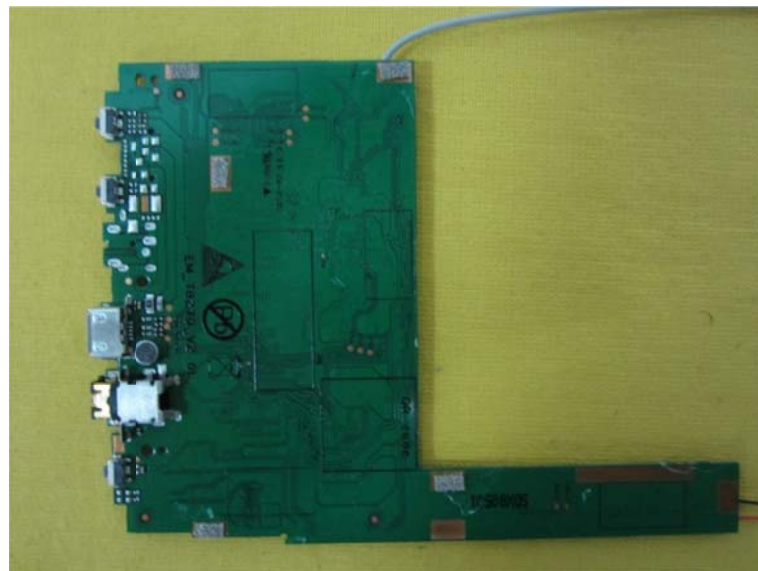

.....End of Report.....