



# TEST REPORT

**Report Reference No.**..... : **TRE1408006501** R/C.....:92788  
**FCC ID**..... : **2AAP6M1041**  
**Applicant's name**..... : **SHENZHEN ZOWEE TECHNOLOGY CO.,LTD**  
 Address..... : Science &Technology Industrial Park of Privately Owned Enterprises, Pingshan, Xili, Nanshan District, Shenzhen, PR CHINA  
 Manufacturer..... : SHENZHEN ZOWEE TECHNOLOGY CO.,LTD  
 Address..... : Science &Technology Industrial Park of Privately Owned Enterprises, Pingshan, Xili, Nanshan District, Shenzhen, PR CHINA  
**Test item description** ..... : **Internet Tablet**  
 Trade Mark ..... : NOBIS,DOPO,TMAX,APEX,D.AGE,NUVISION  
 Model/Type reference..... : M1041  
 Listed Model(s) ..... : NB1022, NB1022S, DPM1081, DPM1081K, D1081, M1081, M1080, D1022, M1022, DM1022, DM1020, DPM1020, NB1020, NB1020S, NB1081, NB1080  
**Standard** ..... : **FCC CFR Title 47 Part 15 Subpart C Section 15.247**  
 Date of receipt of test sample..... : Aug 19, 2014  
 Date of testing..... : Aug 19 ~ Sept 01, 2014  
 Date of issue..... : Sept 01, 2014  
**Result**..... : **PASS**

Compiled by  
 ( position+printed name+signature)...: File administrators Any Yang

*Any Yang*

Supervised by  
 ( position+printed name+signature)...: Project Engineer Lion Cai

*Lion Cai*

Approved by  
 ( position+printed name+signature)...: RF Manager Hans Hu

*Hans Hu*

**Testing Laboratory Name** ..... : **Shenzhen Huatongwei International Inspection Co., Ltd**  
 Address..... : Keji Nan No.12 Road, Hi-tech Park, Shenzhen, China

**Shenzhen Huatongwei International Inspection Co., Ltd. All rights reserved.**

This publication may be reproduced in whole or in part for non-commercial purposes as long as the Shenzhen Huatongwei International Inspection Co., Ltd is acknowledged as copyright owner and source of the material. Shenzhen Huatongwei International Inspection Co., Ltd takes no responsibility for and will not assume liability for damages resulting from the reader's interpretation of the reproduced material due to its placement and context.

## Contents

<b>1.</b>	<b><u>TEST STANDARDS AND TEST DESCRIPTION</u></b>	<b>3</b>
1.1.	Test Standards	3
1.2.	Test Description	3
<b>2.</b>	<b><u>SUMMARY</u></b>	<b>4</b>
2.1.	Client Information	4
2.2.	Product Description	4
2.3.	EUT operation mode	5
2.4.	EUT configuration	5
2.5.	Modifications	5
<b>3.</b>	<b><u>TEST ENVIRONMENT</u></b>	<b>6</b>
3.1.	Address of the test laboratory	6
3.2.	Test Facility	6
3.3.	Environmental conditions	7
3.4.	Statement of the measurement uncertainty	7
3.5.	Equipments Used during the Test	8
<b>4.</b>	<b><u>TEST CONDITIONS AND RESULTS</u></b>	<b>9</b>
4.1.	Antenna requirement	9
4.2.	Conducted Emission (AC Main)	10
4.3.	Conducted Peak Output Power	13
4.4.	Power Spectral Density	14
4.5.	6dB bandwidth	19
4.6.	Band Edge	24
4.7.	Spurious Emission (conducted)	33
4.8.	Spurious Emission (radiated)	35
<b>5.</b>	<b><u>TEST SETUP PHOTOS OF THE EUT</u></b>	<b>53</b>
<b>6.</b>	<b><u>EXTERNAL AND INTERNAL PHOTOS OF THE EUT</u></b>	<b>54</b>

# 1. TEST STANDARDS AND TEST DESCRIPTION

## 1.1. Test Standards

The tests were performed according to following standards:

[FCC Rules Part 15.247](#): Frequency Hopping, Direct Spread Spectrum and Hybrid Systems that are in operation within the bands of 902-928 MHz, 2400-2483.5 MHz, and 5725-5850 MHz.

[ANSI C63.10](#): American National Standard for Testing Unlicensed Wireless Devices

[KDB558074 D01 V03R02](#): Guidance for Performing Compliance Measurements on Digital Transmission Systems (DTS) Operating Under §15.247

## 1.2. Test Description

Test Item	Section in CFR 47	Result
Antenna requirement	15.203/15.247 (c)	Pass
Line Conducted Emission (AC Main)	15.207	Pass
Conducted Peak Output Power	15.247 (b)(3)	Pass
Power Spectral Density	15.247 (e)	Pass
6dB Bandwidth	15.247 (a)(2)	Pass
Band Edge	15.247(d)	Pass
Spurious Emission	15.205/15.209	Pass

Remark: The measurement uncertainty is not included in the test result.

## 2. SUMMARY

### 2.1. Client Information

Applicant:	SHENZHEN ZOWEE TECHNOLOGY CO.,LTD
Address:	Science &Technology Industrial Park of Privately Owned Enterprises, Pingshan, Xili, Nanshan District, Shenzhen, PR CHINA
Manufacturer:	SHENZHEN ZOWEE TECHNOLOGY CO.,LTD
Address:	Science &Technology Industrial Park of Privately Owned Enterprises, Pingshan, Xili, Nanshan District, Shenzhen, PR CHINA

### 2.2. Product Description

Name of EUT	Internet Tablet
Trade Mark:	NOBIS,DOPO,TMAX,APEX,D.AGE,NUVISION
Model No.:	M1041
Listed Model(s):	NB1022, NB1022S, DPM1081, DPM1081K, D1081, M1081, M1080, D1022, M1022, DM1022, DM1020, DPM1020, NB1020, NB1020S, NB1081, NB1080
Power supply:	DC 3.7V From Internal Battery
Adapter information:	Model No.:JK050200-S04USA Input: AC 100~240V, 50/60Hz, 0.5A Output: DC 5.0V 2A
<b>WIFI</b>	
Supported type:	802.11b/802.11g/802.11n(H20)/802.11n(H40)
Modulation:	802.11b: DSSS 802.11g/802.11n(H20)/802.11n(H40):OFDM
Operation frequency:	802.11b/802.11g/802.11n(H20): 2412MHz~2462MHz 802.11n(H40): 2422MHz~2452MHz
Channel number:	802.11b/802.11g/802.11n(H20): 11 802.11n(H40): 7
Channel separation:	5MHz
Antenna type:	Internal Antenna
Antenna gain:	2.0 dBi

Operation Frequency List:

802.11b/g/n(H20)		802.11n(H40)	
Channel	Frequency (MHz)	Channel	Frequency (MHz)
01	2412	01	--
02	2417	02	--
03	2422	03	2422
⋮	⋮	⋮	⋮
06	2437	06	2442
⋮	⋮	⋮	⋮
09	2452	09	2452
10	2457	10	--
11	2462	11	--

Note:

In section 15.31(m), regards to the operating frequency range over 10 MHz, the Lowest frequency, the middle frequency, and the highest frequency of channel were selected to perform the test, please see the above gray bottom.

### 2.3. EUT operation mode

The EUT has been tested under test mode condition. The Applicant provides software to control the EUT for staying in continuous transmitting and receiving mode for testing.

And found which the below bit rate is worst case mode, so only show data which it is a worst case mode.

Mode	Bit rate (worst mode)
802.11b	1Mbps
802.11g	6Mbps
802.11n(H20)	13.5Mbps
802.11n(H40)	13.5Mbps

The EUT was programmed to be in continuously transmitting mode and the transmit duty cycle is not less than 98%.

### 2.4. EUT configuration

The following peripheral devices and interface cables were connected during the measurement:

● - supplied by the manufacturer

○ - supplied by the lab

<input type="radio"/>	Power Cable	Length (m) :	/
		Shield :	/
		Detachable :	/
<input type="radio"/>	Multimeter	Manufacturer :	/
		Model No. :	/

### 2.5. Modifications

No modifications were implemented to meet testing criteria.

### **3. TEST ENVIRONMENT**

#### **3.1. Address of the test laboratory**

Test Laboratory: Shenzhen Huatongwei International Inspection Co., Ltd  
Address: Keji Nan No.12 Road, Hi-tech Park, Shenzhen, China  
Phone: 86-755-26715686 Fax: 86-755-26748089

#### **3.2. Test Facility**

The test facility is recognized, certified, or accredited by the following organizations:

##### **CNAS-Lab Code: L1225**

Shenzhen Huatongwei International Inspection Co., Ltd. has been assessed and proved to be in compliance with CNAS-CL01 Accreditation Criteria for Testing and Calibration Laboratories (identical to ISO/IEC 17025: 2005 General Requirements) for the Competence of Testing and Calibration Laboratories, Date of Registration: Mar. 01, 2012. Valid time is until February 28, 2015.

##### **A2LA-Lab Cert. No. 2243.01**

Shenzhen Huatongwei International Inspection Co., Ltd. EMC Laboratory has been accredited by A2LA for technical competence in the field of electrical testing, and proved to be in compliance with ISO/IEC 17025: 2005 General Requirements for the Competence of Testing and Calibration Laboratories and any additional program requirements in the identified field of testing. Valid time is until Sept 30, 2015.

##### **FCC-Registration No.: 662850**

Shenzhen Huatongwei International Inspection Co., Ltd. EMC Laboratory has been registered and fully described in a report filed with the FCC (Federal Communications Commission). The acceptance letter from the FCC is maintained in our files. Registration 662850, Renewal date Jul. 01, 2012, valid time is until Jun. 01, 2015.

##### **IC-Registration No.: 5377A**

The 3m Alternate Test Site of Shenzhen Huatongwei International Inspection Co., Ltd. has been registered by Certification and Engineering Bureau of Industry Canada for the performance of radiated measurements with Registration No. 5377A on Dec. 31, 2013, valid time is until Dec. 31, 2016.

##### **ACA**

Shenzhen Huatongwei International Inspection Co., Ltd. EMC Laboratory can also perform testing for the Australian C-Tick mark as a result of our A2LA accreditation.

##### **VCCI**

The 3m Semi-anechoic chamber (12.2m×7.95m×6.7m) of Shenzhen Huatongwei International Inspection Co., Ltd. has been registered in accordance with the Regulations for Voluntary Control Measures with Registration No.:R-2484. Date of Registration: Dec. 20, 2012. Valid time is until Dec. 29, 2015.

Radiated disturbance above 1GHz measurement of Shenzhen Huatongwei International Inspection Co., Ltd. has been registered in accordance with the Regulations for Voluntary Control Measures with Registration No.: G-292. Date of Registration: Dec. 24, 2013. Valid time is until Dec. 23, 2016.

Main Ports Conducted Interference Measurement of Shenzhen Huatongwei International Inspection Co., Ltd. has been registered in accordance with the Regulations for Voluntary Control Measures with Registration No.: C-2726. Date of Registration: Dec. 20, 2012. Valid time is until Dec. 19, 2015.

Telecommunication Ports Conducted Interference Measurement of Shenzhen Huatongwei International Inspection Co., Ltd. has been registered in accordance with the Regulations for Voluntary Control Measures with Registration No.: T-1837. Date of Registration: May 07, 2013. Valid time is until May 06, 2016.

##### **DNV**

Shenzhen Huatongwei International Inspection Co., Ltd. has been found to comply with the requirements of DNV towards subcontractor of EMC and safety testing services in conjunction with the EMC and Low voltage Directives and in the voluntary field. The acceptance is based on a formal quality Audit and follow-ups according to relevant parts of ISO/IEC Guide 17025 (2005), in accordance with the requirements of the DNV Laboratory Quality Manual towards subcontractors. Valid time is until Aug. 24, 2016.

### 3.3. Environmental conditions

During the measurement the environmental conditions were within the listed ranges:

Temperature:	15~35°C
Relative Humidity:	30~60 %
Air Pressure:	950~1050mba

### 3.4. Statement of the measurement uncertainty

The data and results referenced in this document are true and accurate. The reader is cautioned that there may be errors within the calibration limits of the equipment and facilities. The measurement uncertainty was calculated for all measurements listed in this test report according to TR-100028-01 "Electromagnetic compatibility and Radio spectrum Matters (ERM); Uncertainties in the measurement of mobile radio equipment characteristics; Part 1" and TR-100028-02 "Electromagnetic compatibility and Radio spectrum Matters (ERM); Uncertainties in the measurement of mobile radio equipment characteristics; Part 2" and is documented in the Shenzhen Huatongwei International Inspection Co., Ltd quality system according to DIN EN ISO/IEC 17025. Furthermore, component and process variability of devices similar to that tested may result in additional deviation. The manufacturer has the sole responsibility of continued compliance of the device.

Hereafter the best measurement capability for Shenzhen Huatongwei laboratory is reported:

Test Items	Measurement Uncertainty	Notes
Transmitter power conducted	0.57 dB	(1)
Transmitter power Radiated	2.20 dB	(1)
Conducted spurious emission 9KHz-40 GHz	1.60 dB	(1)
Radiated spurious emission 9KHz-40 GHz	2.20 dB	(1)
Conducted Emission 9KHz-30MHz	3.39 dB	(1)
Radiated Emission 30~1000MHz	4.24 dB	(1)
Radiated Emission 1~18GHz	5.16 dB	(1)
Radiated Emission 18-40GHz	5.54 dB	(1)
Occupied Bandwidth	-----	(1)

(1) This uncertainty represents an expanded uncertainty expressed at approximately the 95% confidence level using a coverage factor of  $k=1.96$ .

**3.5. Equipments Used during the Test**

AC Power Conducted Emission					
Item	Test Equipment	Manufacturer	Model No.	Serial No.	Cal Due
1	Artificial Mains	Rohde&Schwarz	ESH2-Z5	100028	2014/10/25
2	EMI Test Receiver	Rohde&Schwarz	ESCI3	100038	2014/10/25
3	Pulse Limiter	Rohde&Schwarz	ESHSZ2	100044	2014/10/25
4	EMI Test Software	Rohde&Schwarz	ES-K1 V1.71	N/A	N/A

Radiated Emission					
Item	Test Equipment	Manufacturer	Model No.	Serial No.	Cal Due
1	Ultra-Broadband Antenna	ShwarzBeck	VULB9163	538	2014/10/25
2	EMI TEST RECEIVER	Rohde&Schwarz	ESI 26	100009	2014/10/25
3	EMI TEST Software	Audix	E3	N/A	N/A
4	TURNTABLE	ETS	2088	2149	N/A
5	ANTENNA MAST	ETS	2075	2346	N/A
6	EMI TEST Software	Rohde&Schwarz	ESK1	N/A	N/A
7	HORN ANTENNA	ShwarzBeck	9120D	1011	2014/10/25
8	Amplifer	Sonoma	310N	E009-13	2014/10/25
9	JS amplifer	Rohde&Schwarz	JS4-00101800-28-5A	F201504	2014/10/25
10	High pass filter	Compliance Direction systems	BSU-6	34202	2014/10/25
11	HORN ANTENNA	ShwarzBeck	9120D	1012	2014/10/25
12	Amplifer	Compliance Direction systems	PAP1-4060	120	2014/10/25
13	Loop Antenna	Rohde&Schwarz	HFH2-Z2	100020	2014/10/25
14	TURNTABLE	MATURO	TT2.0	----	N/A
15	ANTENNA MAST	MATURO	TAM-4.0-P	----	N/A
16	Horn Antenna	SCHWARZBECK	BBHA9170	25841	2014/10/25
17	ULTRA-BROADBAND ANTENNA	Rohde&Schwarz	HL562	100015	2014/10/25

Maximum Peak Output Power / Power Spectral Density / 6dB Bandwidth / Band Edge Compliance of RF Emission / Spurious RF Conducted Emission					
Item	Test Equipment	Manufacturer	Model No.	Serial No.	Cal Due
1	Spectrum Analyzer	Rohde&Schwarz	FSP	1164.4391.40	2014/10/25
2	Power Meter	Anritsu	MA2411B	100258	2014/10/25

The Cal.Interval was one year



## 4. TEST CONDITIONS AND RESULTS

### 4.1. Antenna requirement

#### Requirement

##### **FCC CFR Title 47 Part 15 Subpart C Section 15.203:**

An intentional radiator shall be designed to ensure that no antenna other than that furnished by the responsible party shall be used with the device. The use of a permanently attached antenna or of an antenna that uses a unique coupling to the intentional radiator, the manufacturer may design the unit so that a broken antenna can be replaced by the user, but the use of a standard antenna jack or electrical connector is prohibited.

##### **FCC CFR Title 47 Part 15 Subpart C Section 15.247(c) (1)(i):**

(i) Systems operating in the 2400-2483.5 MHz band that is used exclusively for fixed. Point-to-point operations may employ transmitting antennas with directional gain greater than 6dBi provided the maximum conducted output power of the intentional radiator is reduced by 1 dB for every 3 dB that the directional gain of the antenna exceeds 6dBi.

#### Test Result:

The antenna is integral antenna, the best case gain of the antenna is 2dBi



## 4.2. Conducted Emission (AC Main)

### LIMIT

FCC CFR Title 47 Part 15 Subpart C Section 15.207

Frequency range (MHz)	Limit (dBuV)	
	Quasi-peak	Average
0.15-0.5	66 to 56*	56 to 46*
0.5-5	56	46
5-30	60	50

\* Decreases with the logarithm of the frequency.

### TEST CONFIGURATION

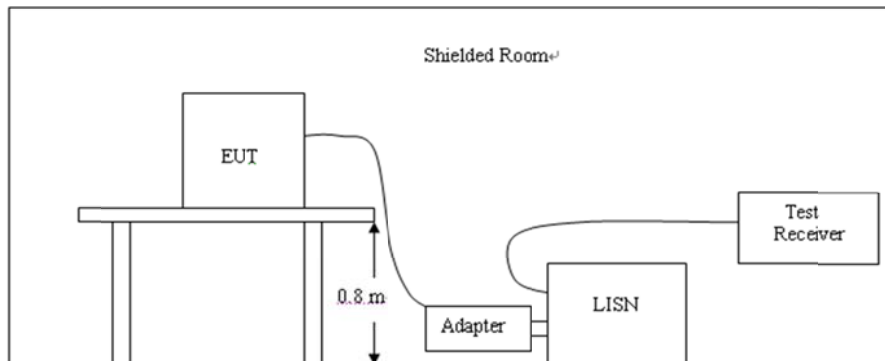

### TEST PROCEDURE

1. The EUT was setup according to ANSI C63.4: 2009 and tested according to ANSI C63.10:2009 for compliance to FCC 47CFR 15.247 requirements.
2. The EUT was placed on a platform of nominal size, 1 m by 1.5 m, raised 80 cm above the conducting ground plane. The vertical conducting plane was located 40 cm to the rear of the EUT. All other surfaces of EUT were at least 80 cm from any other grounded conducting surface.
3. The EUT and simulators are connected to the main power through a line impedance stabilization network (LISN). The LISN provides a 50 ohm /50uH coupling impedance for the measuring equipment.
4. The peripheral devices are also connected to the main power through a LISN. (Please refer to the block diagram of the test setup and photographs)
5. Each current-carrying conductor of the EUT power cord, except the ground (safety) conductor, was individually connected through a LISN to the input power source.
6. The excess length of the power cord between the EUT and the LISN receptacle were folded back and forth at the center of the lead to form a bundle not exceeding 40 cm in length.
7. Conducted emissions were investigated over the frequency range from 0.15MHz to 30MHz using a receiver bandwidth of 9 kHz.

### TEST RESULTS

Test mode:		Polarization	L
------------	--	--------------	---

**SCAN TABLE: "Voltage (9K-30M)FIN"**  
 Short Description: 150K-30M Voltage

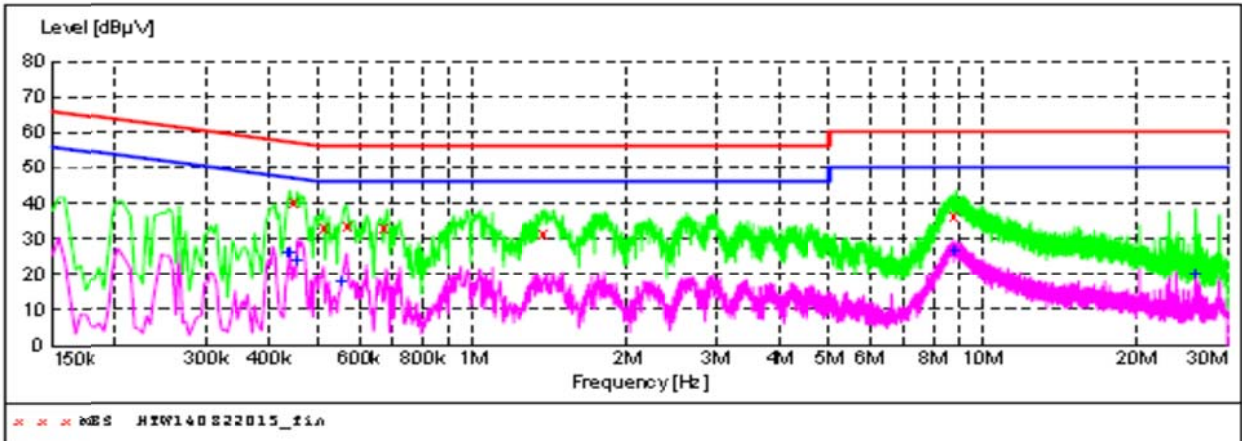

**MEASUREMENT RESULT: "HW140822015\_fin"**

8/22/2014 2:57PM

Frequency MHz	Level dBµV	Transd dB	Limit dBµV	Margin dB	Detector	Line	PE
0.446000	40.60	10.2	57	16.3	QP	L1	GND
0.510000	32.90	9.9	56	23.1	QP	L1	GND
0.566000	33.90	9.9	56	22.1	QP	L1	GND
0.674000	33.00	9.9	56	23.0	QP	L1	GND
1.374000	31.20	10.1	56	24.8	QP	L1	GND
8.778000	36.70	10.3	60	23.3	QP	L1	GND

**MEASUREMENT RESULT: "HW140822015\_fin2"**

8/22/2014 2:57PM

Frequency MHz	Level dBµV	Transd dB	Limit dBµV	Margin dB	Detector	Line	PE
0.434000	26.40	10.3	47	20.8	AV	L1	GND
0.438000	26.60	10.3	47	20.5	AV	L1	GND
0.454000	24.40	10.2	47	22.4	AV	L1	GND
0.554000	18.40	9.9	46	27.6	AV	L1	GND
8.806000	26.80	10.3	50	23.2	AV	L1	GND
26.018000	20.70	10.7	50	29.3	AV	L1	GND

Test mode:		Polarization	N
------------	--	--------------	---

**SCAN TABLE: "Voltage (9K-30M)FIN"**  
 Short Description: 150K-30M Voltage

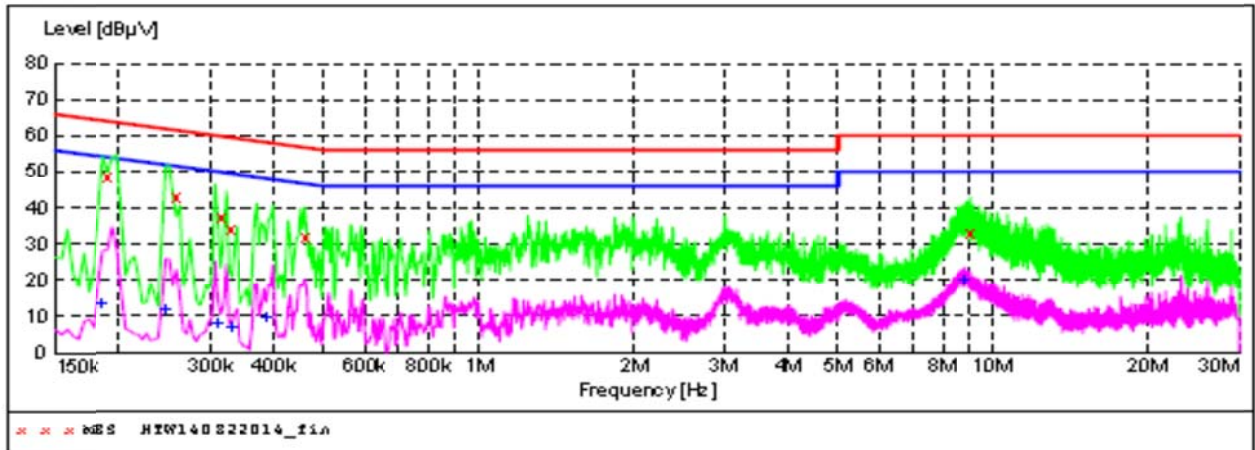

**MEASUREMENT RESULT: "HW140822014\_fin"**

8/22/2014 2:54PM

Frequency MHz	Level dBµV	Transd dB	Limit dBµV	Margin dB	Detector	Line	PE
0.190000	48.70	12.1	64	15.3	QP	N	GND
0.258000	42.90	11.8	62	18.6	QP	N	GND
0.314000	37.70	11.4	60	22.2	QP	N	GND
0.330000	34.50	11.2	60	25.0	QP	N	GND
0.458000	32.10	10.1	57	24.6	QP	N	GND
9.014000	33.30	10.3	60	26.7	QP	N	GND

**MEASUREMENT RESULT: "HW140822014\_fin2"**

8/22/2014 2:54PM

Frequency MHz	Level dBµV	Transd dB	Limit dBµV	Margin dB	Detector	Line	PE
0.186000	13.60	12.1	54	40.6	AV	N	GND
0.246000	12.00	11.8	52	39.9	AV	N	GND
0.310000	8.40	11.5	50	41.6	AV	N	GND
0.330000	7.40	11.2	50	42.1	AV	N	GND
0.386000	9.70	10.6	48	38.4	AV	N	GND
8.778000	20.60	10.3	50	29.4	AV	N	GND

### 4.3. Conducted Peak Output Power

**LIMIT**

FCC CFR Title 47 Part 15 Subpart C Section 15.247 (b)(3): **30dBm**

**TEST CONFIGURATION**



**TEST PROCEDURE**

1. The EUT was tested according to ANSI C63.10: 2009 and KDB 558074 D01 V03R02 for compliance to FCC 47CFR 15.247 requirements.
2. Use the wideband power meter to test peak power and record the result.

**TEST RESULTS**

Type	Channel	Output power (dBm)	Limit (dBm)	Result
802.11b	01	21.62	30.00	Pass
	06	21.98		
	11	22.22		
802.11g	01	17.65	30.00	Pass
	06	18.83		
	11	18.42		
802.11n(H20)	01	19.89	30.00	Pass
	06	21.20		
	11	20.06		
802.11n(H40)	03	17.65	30.00	Pass
	06	20.01		
	09	17.99		

### 4.4. Power Spectral Density

**LIMIT**

FCC CFR Title 47 Part 15 Subpart C Section 15.247 (e): **8dBm/3KHz**

*For digitally modulated systems, the power spectral density conducted from the intentional radiator to the antenna shall not be greater than 8 dBm in any 3 kHz band during any time interval of continuous transmission.*

**TEST CONFIGURATION**



**TEST PROCEDURE**

1. According to KDB 558074 D01 V03R02 Method PKPSD (peak PSD) This procedure shall be used if maximum peak conducted output power was used to demonstrate compliance, and is optional if the maximum conducted (average) output power was used to demonstrate compliance.
2. Analyzer set:  
Center frequency =Channel center frequency  
RBW =3 kHz~100 kHz, VBW≥3RBW, Detector=Peak, Span=1.5 times the bandwidth
3. Allow trace to fully stabilize, use the peak marker function to determine the maximum amplitude level within the RBW.
4. If measured value exceeds limit, reduce RBW (no less than 3 kHz) and repeat.

**TEST RESULTS**

Type	Channel	Power Spectral Density (dBm/3KHz)	Limit (dBm/3KHz)	Result
802.11b	01	-3.462	8.00	Pass
	06	-4.463		
	11	-2.954		
802.11g	01	-9.806	8.00	Pass
	06	-7.243		
	11	-9.001		
802.11n(H20)	01	-8.792	8.00	Pass
	06	-6.646		
	11	-7.984		
802.11n(H40)	03	-14.4	8.00	Pass
	06	-12.94		
	09	-14.95		

Test plot as follows:

802.11b

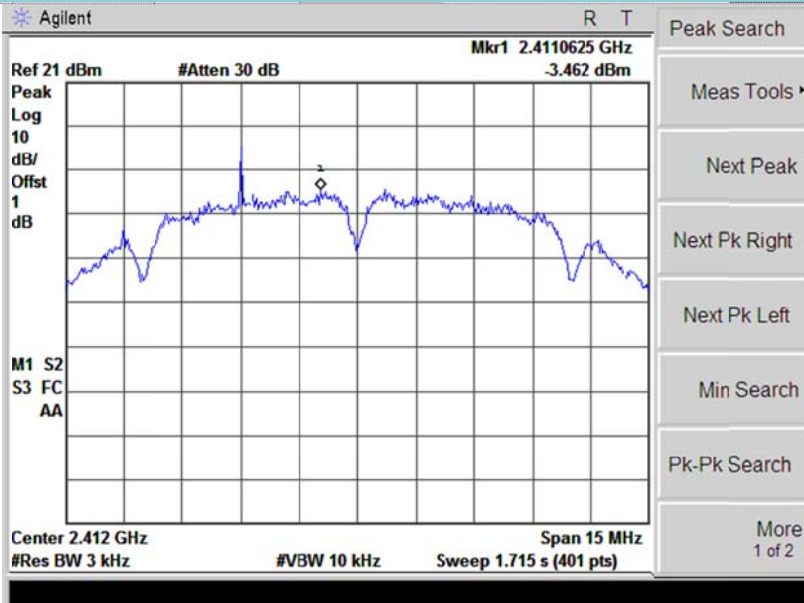

CH01

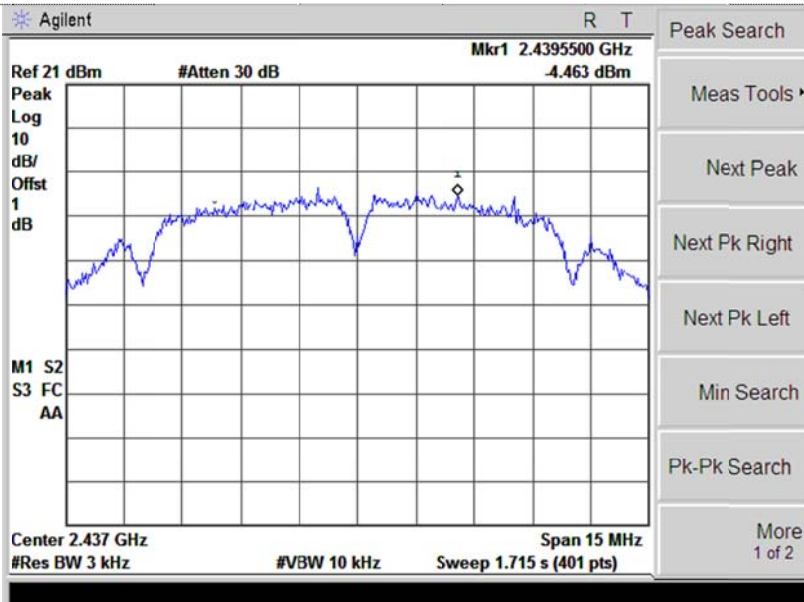

CH06

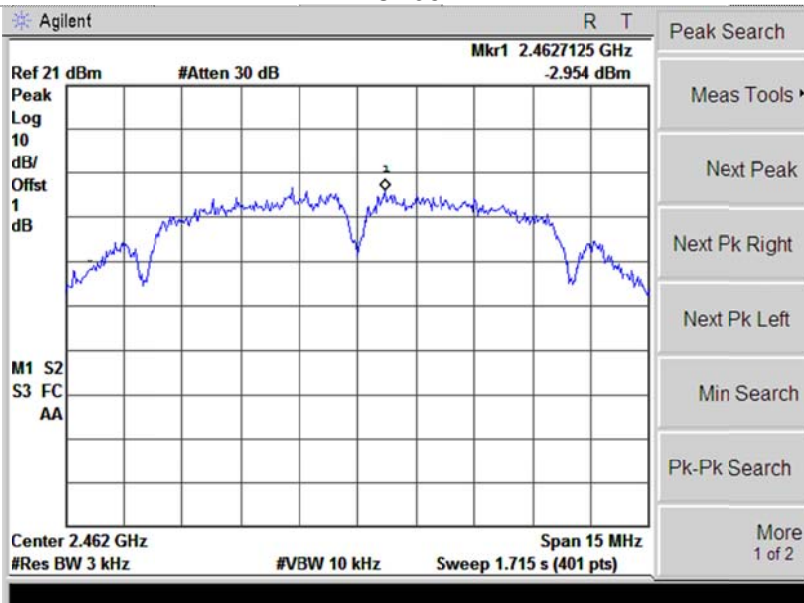

CH11

802.11g

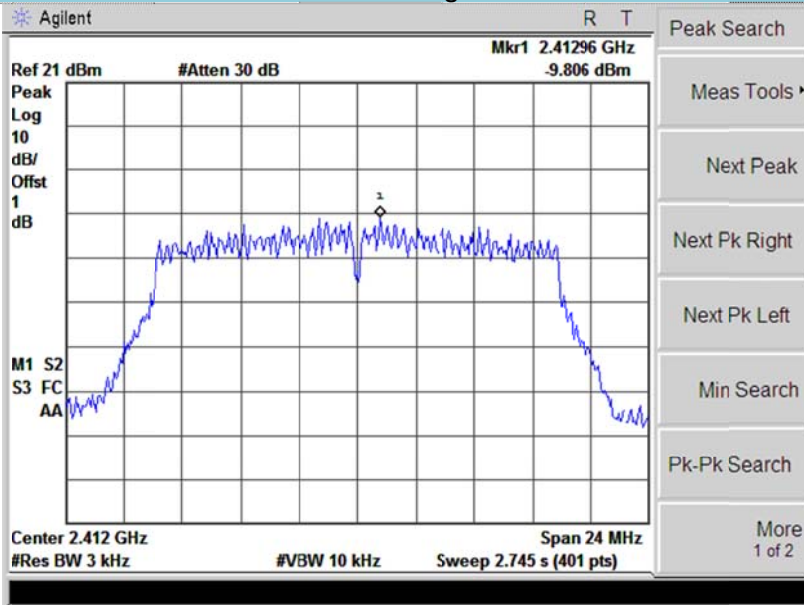

CH01

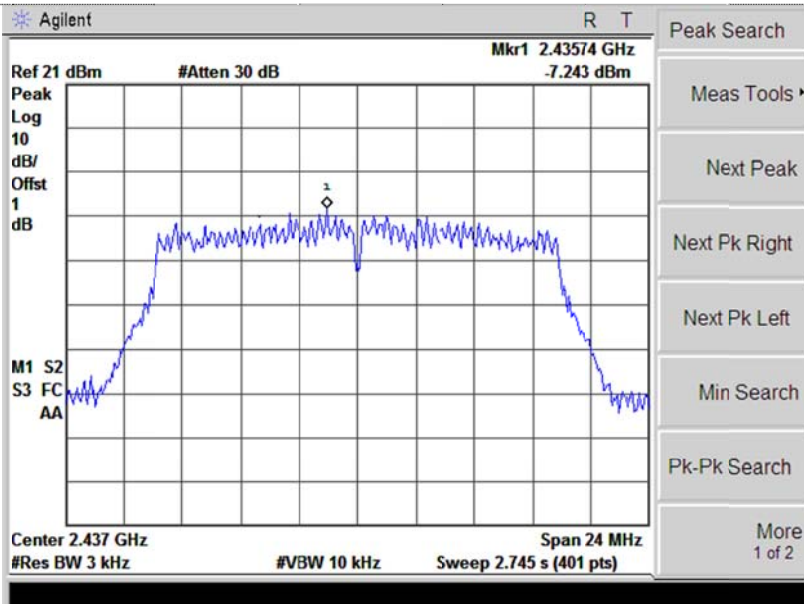

CH06

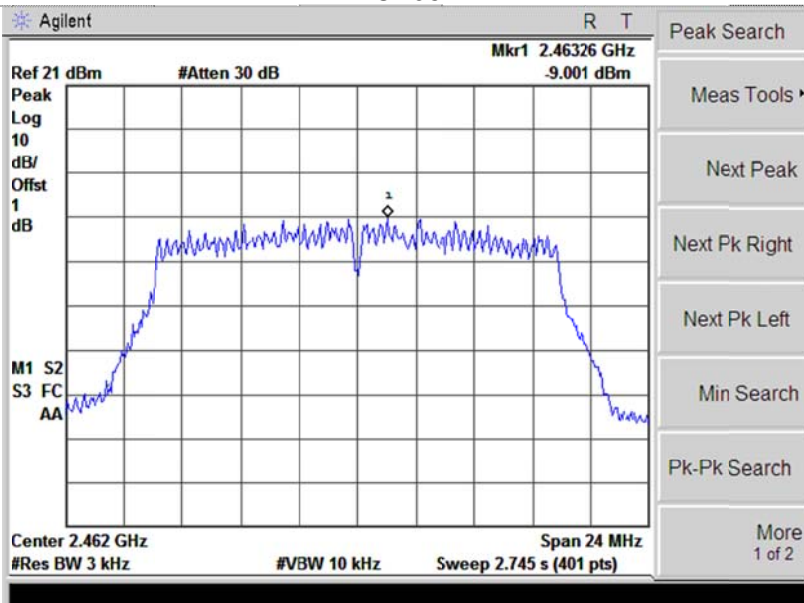

CH11



802.11n(H20)

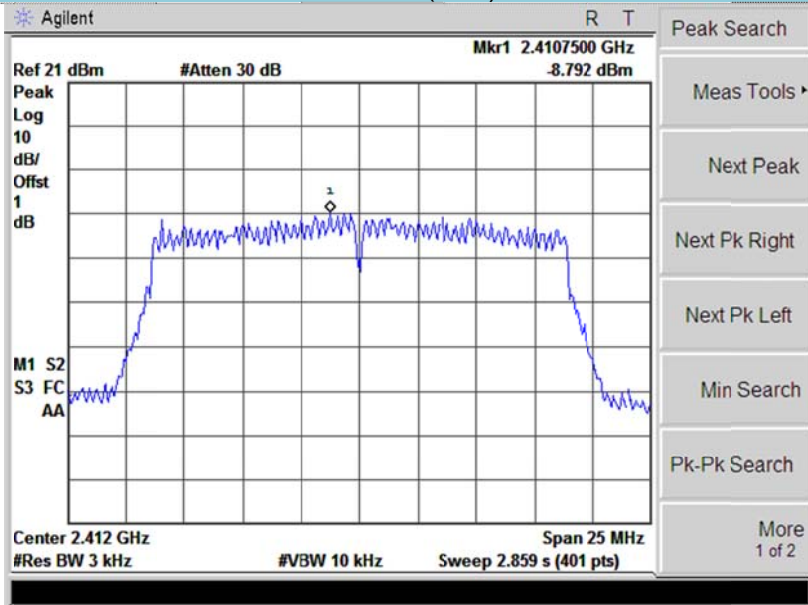

CH01

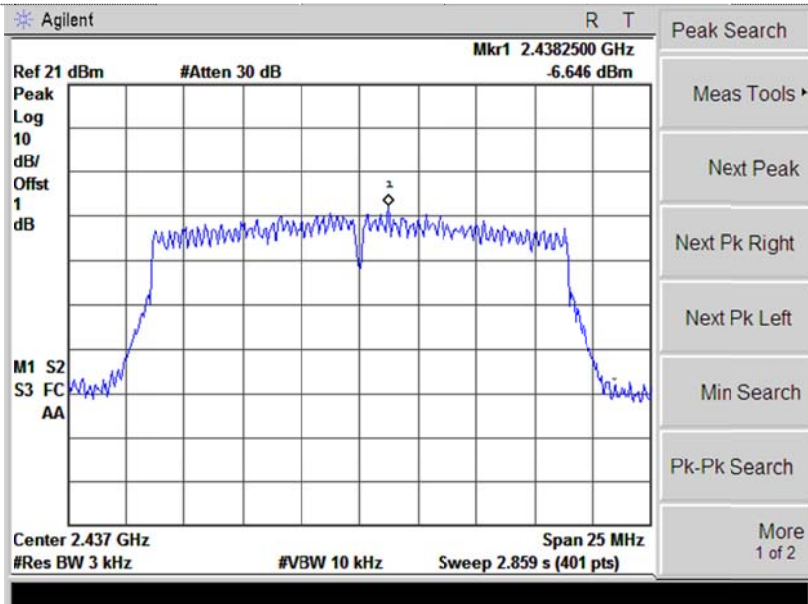

CH06

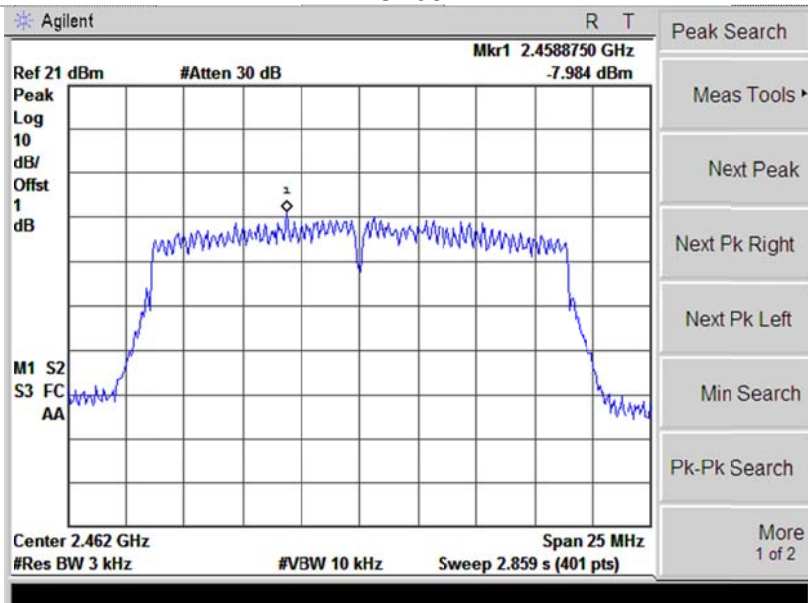

CH11

802.11n(H40)

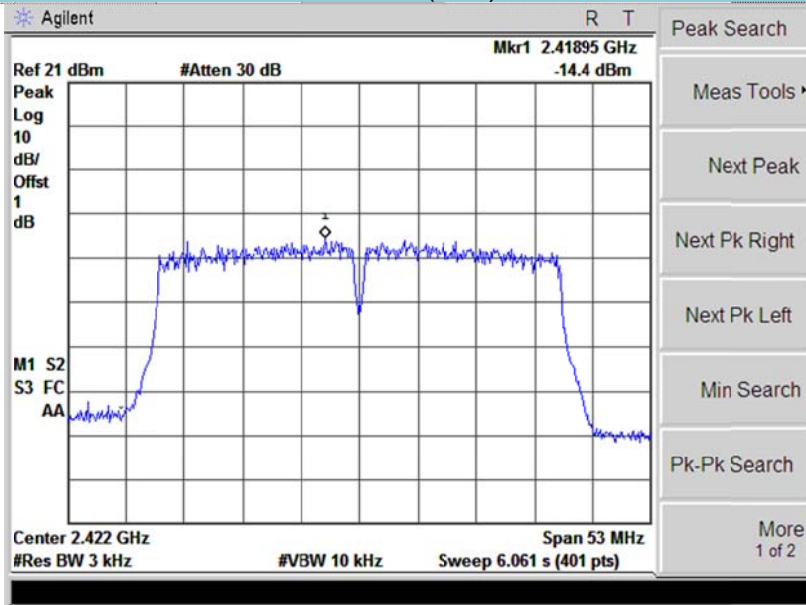

CH03

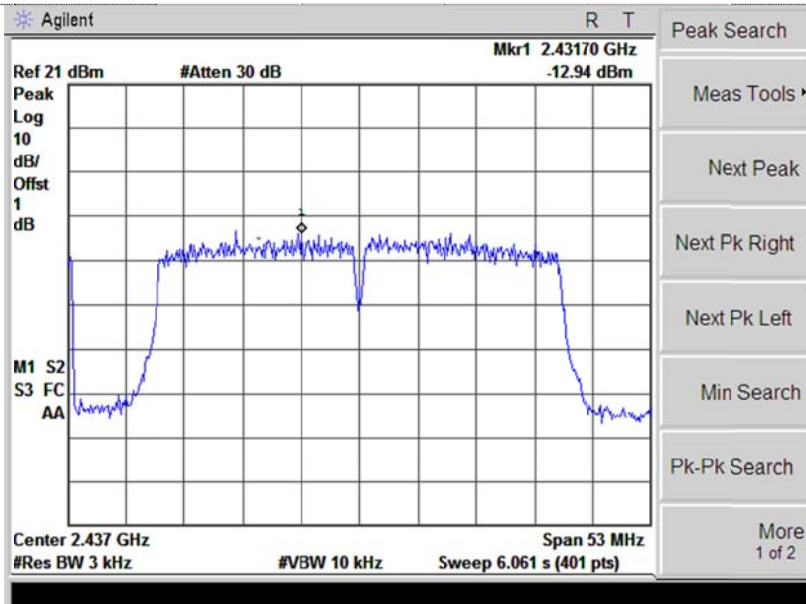

CH06

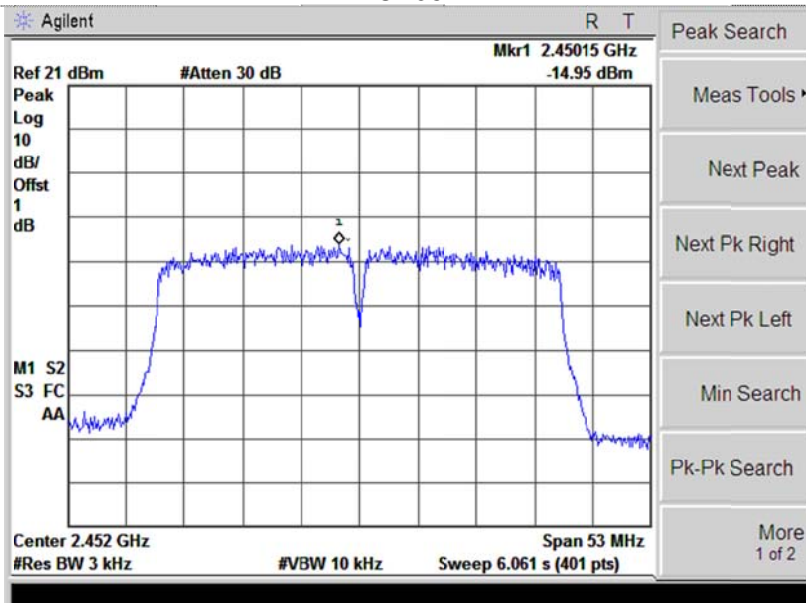

CH09

**4.5. 6dB bandwidth**

**LIMIT**

FCC CFR Title 47 Part 15 Subpart C Section 15.247 (a)(2): **at least 500KHz**

*For digital modulation systems, the minimum 6 dB bandwidth shall be at least 500 kHz.*

**TEST CONFIGURATION**



**TEST PROCEDURE**

1. The transmitter output was connected to the spectrum analyzer through an attenuator. The bandwidth of the fundamental frequency was measured by spectrum analyzer
2. The 6dB bandwidth is defined as the total spectrum the power of which is higher than peak power minus 6dB.
3. According to KDB 558074 D01 V03R02 for one of the following procedures may be used to determine the modulated DTS device signal bandwidth.  
Center frequency =Channel center frequency  
RBW =100 kHz, VBW ≥3RBW, Detector=Peak,
4. Allow the trace to stabilize.
5. Measure the maximum width of the emission that is constrained by the frequencies associated with the two outermost amplitude points (upper and lower frequencies) that are attenuated by 6 dB relative to the maximum level measured in the fundamental emission.

**TEST RESULTS**

Type	Channel	6dB Bandwidth(MHz)	Limit (KHz)	Result
802.11b	01	9.134	≥500	Pass
	06	9.595		
	11	9.138		
802.11g	01	15.721	≥500	Pass
	06	15.328		
	11	15.630		
802.11n(H20)	01	17.138	≥500	Pass
	06	17.160		
	11	17.127		
802.11n(H40)	03	35.206	≥500	Pass
	06	35.174		
	09	35.273		

Test plot as follows:

802.11b

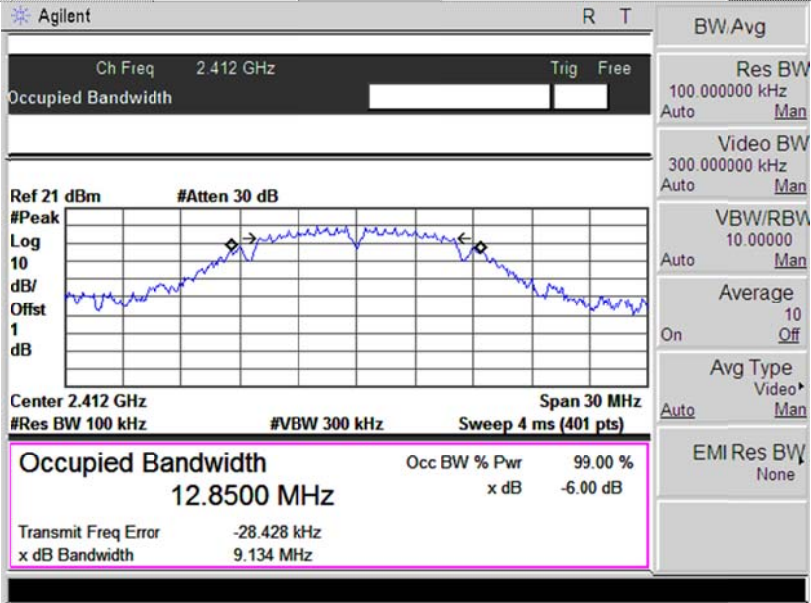

CH01

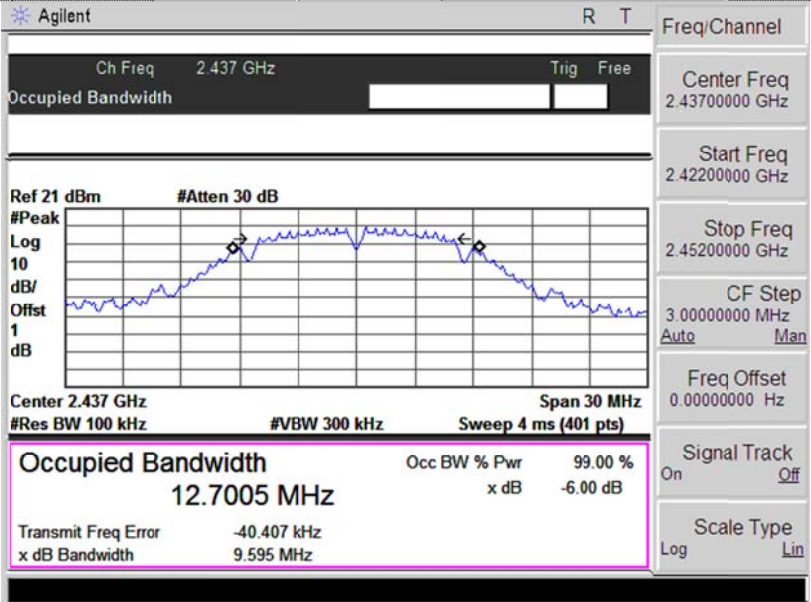

CH06

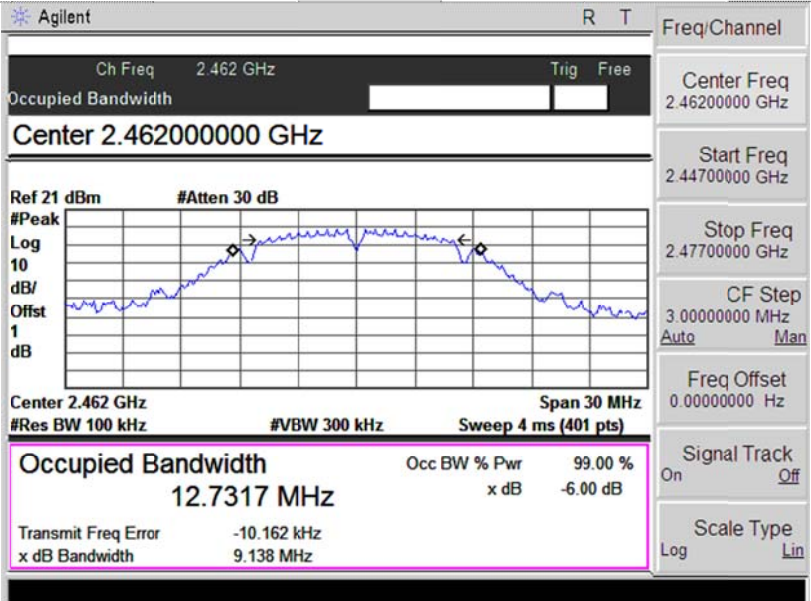

CH11

802.11g

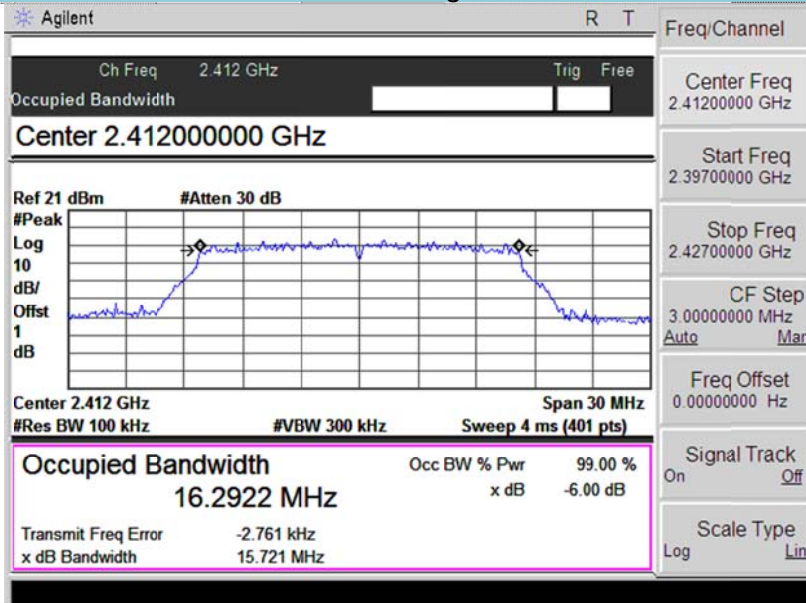

CH01

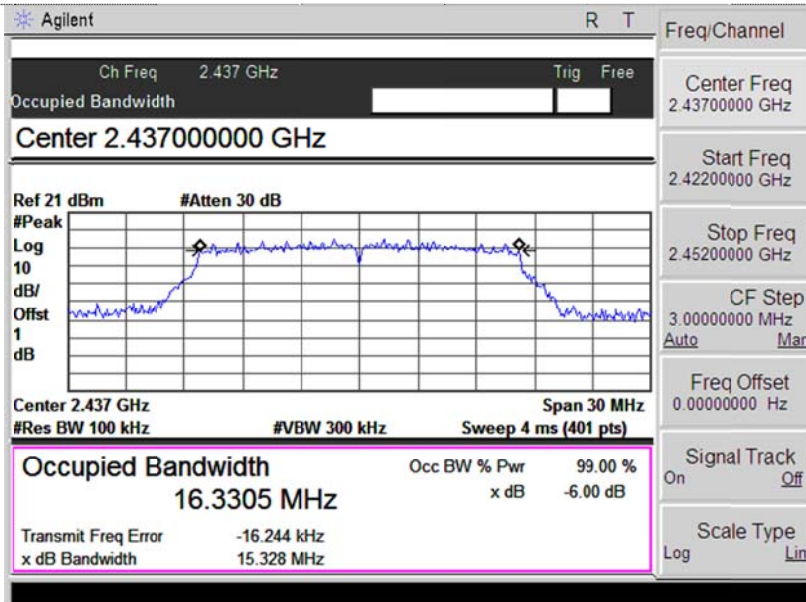

CH06

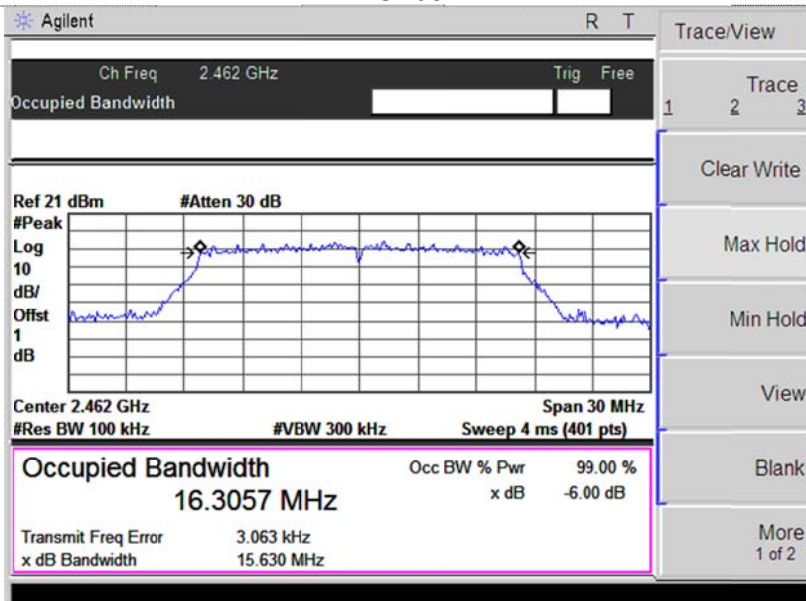

CH11

802.11n(H20)

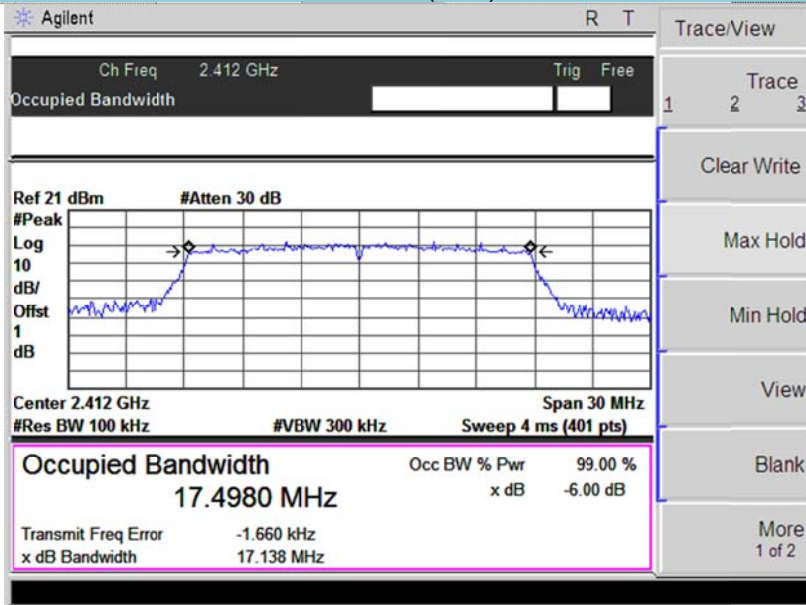

CH01

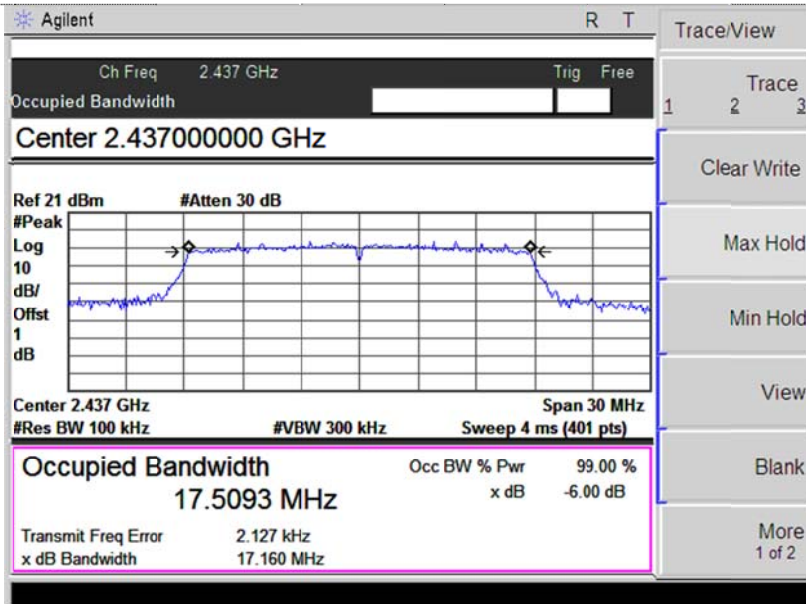

CH06

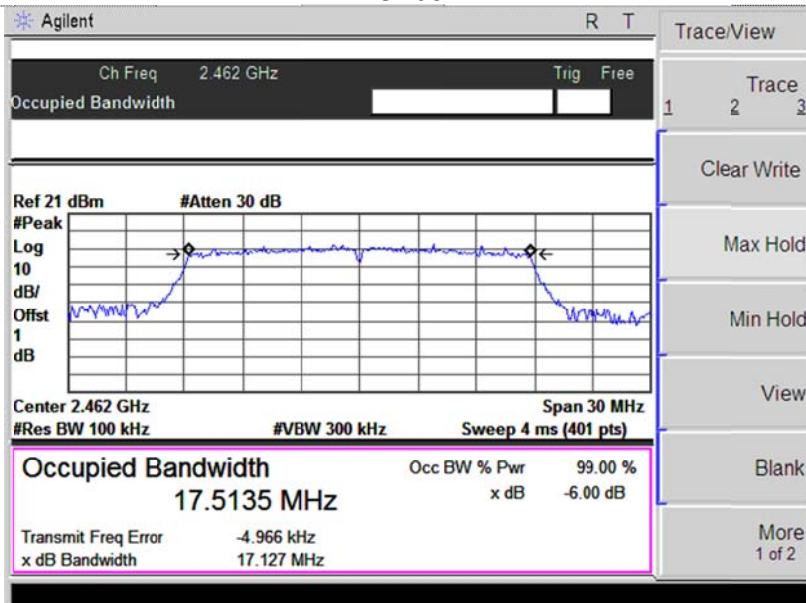

CH11

802.11n(H40)

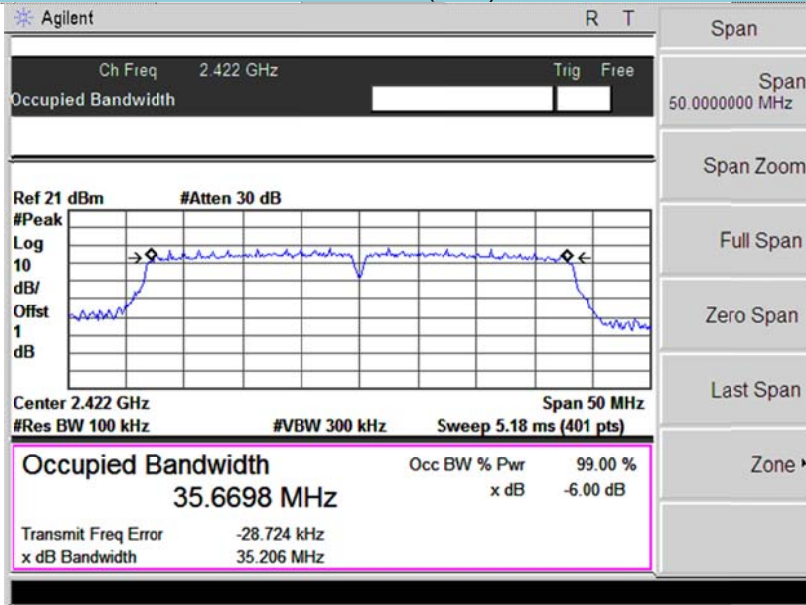

CH03

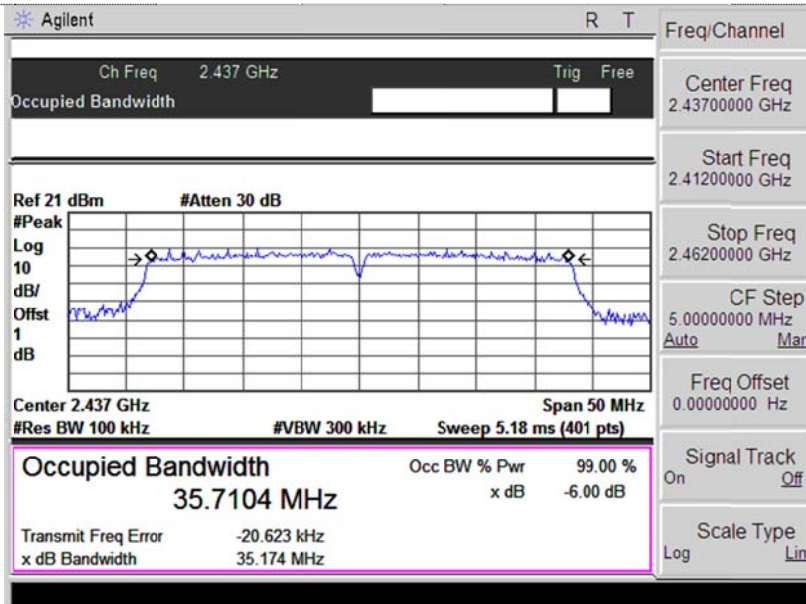

CH06

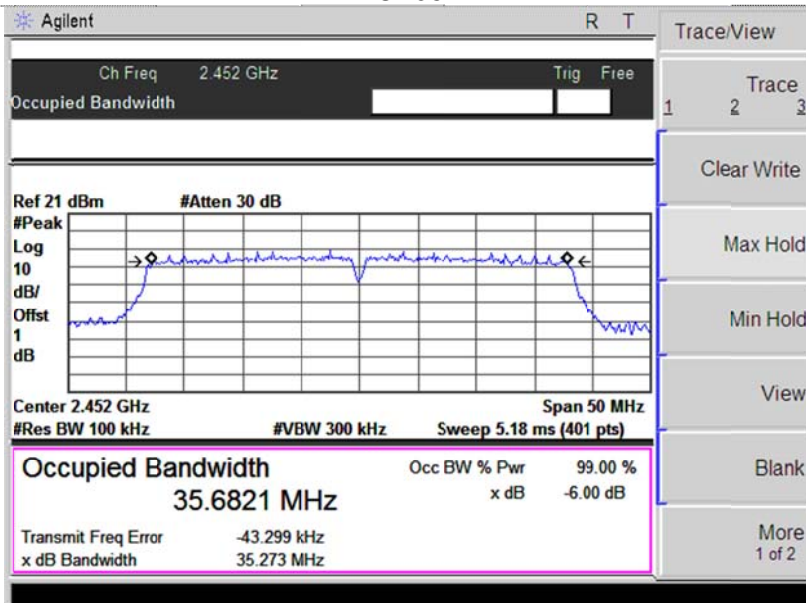

CH09

## 4.6. Band Edge

### LIMIT

FCC CFR Title 47 Part 15 Subpart C Section 15.247 (d):

*In any 100 kHz bandwidth outside the frequency band in which the spread spectrum or digitally modulated intentional radiator is operating, the radio frequency power that is produced by the intentional radiator shall be at least 20 dB below that in the 100 kHz bandwidth within the band that contains the highest level of the desired power, based on either an RF conducted or a radiated measurement, provided the transmitter demonstrates compliance with the peak conducted power limits. If the transmitter complies with the conducted power limits based on the use of RMS averaging over a time interval, as permitted under paragraph (b)(3) of this section, the attenuation required under this paragraph shall be 30 dB instead of 20 dB. Attenuation below the general limits specified in §15.209(a) is not required. In addition, radiated emissions which fall in the restricted bands, as defined in §15.205(a), must also comply with the radiated emission limits specified in §15.209(a) (see §15.205(c)).*

### TEST CONFIGURATION



### TEST PROCEDURE

1. According to KDB 558074 D01 V03R02 for Antenna-port conducted measurement. Antenna-port conducted measurements may also be used as an alternative to radiated measurements for demonstrating compliance in the restricted frequency bands. If conducted measurements are performed, then proper impedance matching must be ensured and an additional radiated test for cabinet/case spurious emissions is required.
2. Remove the antenna from the EUT and then connect to a low loss RF cable from the antenna port to a EMI test receiver, then turn on the EUT and make it operate in transmitting mode. Then set it to Low Channel and High Channel within its operating range, and make sure the instrument is operated in its linear range.
3. Set both RBW and VBW of spectrum analyzer to 100 kHz with a convenient frequency span including 100kHz bandwidth from band edge, for Radiated emissions restricted band RBW=1MHz, VBW=3MHz for peak detector and RBW=1MHz, VBW=10Hz for average detector.
4. Measure the highest amplitude appearing on spectral display and set it as a reference level. Plot the graph with marking the highest point and edge frequency.
5. Repeat above procedures until all measured frequencies were complete.
6. Measure the conducted output power (in dBm) using the detector specified by the appropriate regulatory agency
7. Add the maximum transmit antenna gain (in dBi) to the measured output power level to determine the EIRP level
8. Add the appropriate maximum ground reflection factor to the EIRP level (6 dB for frequencies  $\leq$  30 MHz, 4.7 dB for frequencies between 30 MHz and 1000 MHz, inclusive and 0 dB for frequencies  $>$  1000 MHz).
9. For devices with multiple antenna-ports, measure the power of each individual chain and sum the EIRP of all chains in linear terms (e.g., Watts, mW).
10. Convert the resultant EIRP level to an equivalent electric field strength using the following relationship:  
 $E = \text{EIRP} - 20\log D + 104.8$   
 where:  
 E = electric field strength in dB $\mu$ V/m,  
 EIRP = equivalent isotropic radiated power in dBm  
 D = specified measurement distance in meters.
11. Since the out-of-band characteristics of the EUT transmit antenna will often be unknown, the use of a conservative antenna gain value is necessary. Thus, when determining the EIRP based on the measured conducted power, the upper bound on antenna gain for a device with a single RF output shall be selected as the maximum in-band gain of the antenna across all operating bands, or 2 dBi, whichever is greater. However, for devices that operate in multiple frequency bands while using the same transmit antenna, the highest gain of the antenna within the operating band nearest in frequency to the restricted band emission being measured may be used in lieu of the overall highest gain when the emission is at a frequency that is within 20 percent of the nearest band edge frequency, but in no case shall a value less than 2 dBi be used.
12. Compare the resultant electric field strength level to the applicable regulatory limit.
13. Perform radiated spurious emission test dures until all measured frequencies were complete.

### TEST RESULTS



Mode: 802.11b Test channel: 2412MHz

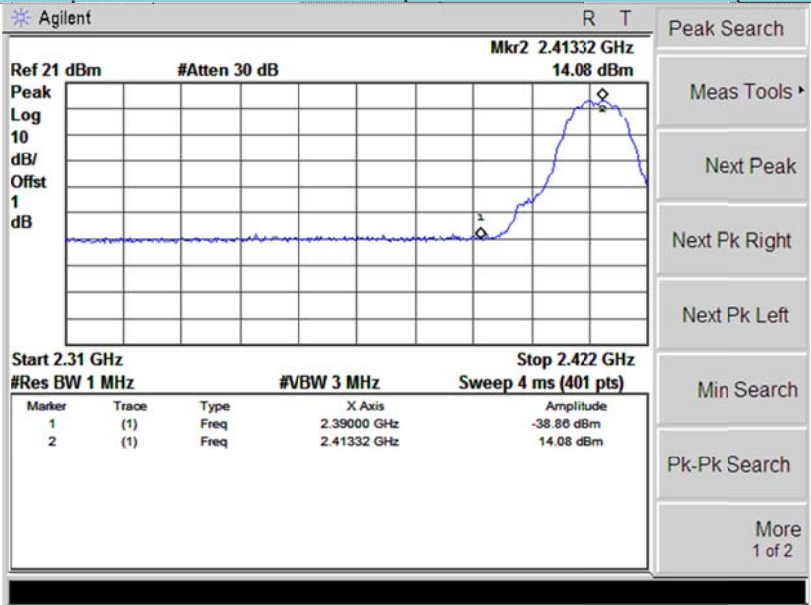

Peak

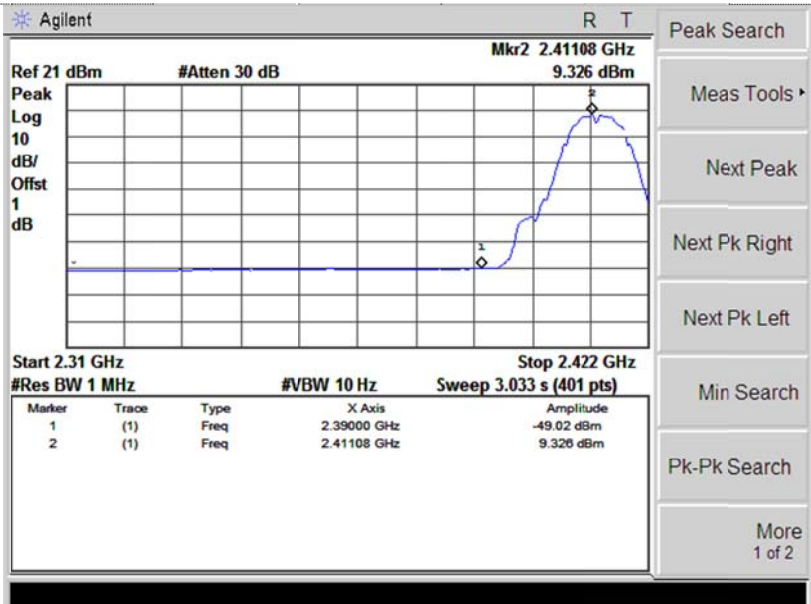

Average

Frequency (MHz)	Conducted Power (dBm)	Antenna Gain (dBi)	Ground Reflection Factor (dB)	Covert Radiated E Level at 3m (dBuV/m)	Detector	Limit (dBuV/m)	Result
2390.00	-38.86	2.00	0.00	58.4	Peak	74.00	Pass
2413.32	14.08	2.00	0.00	111.34	Peak		Pass
2390.00	-49.02	2.00	0.00	48.24	Average	54.00	Pass
2411.08	9.326	2.00	0.00	106.586	Average		Pass

Mode: 802.11b Test channel: 2462MHz

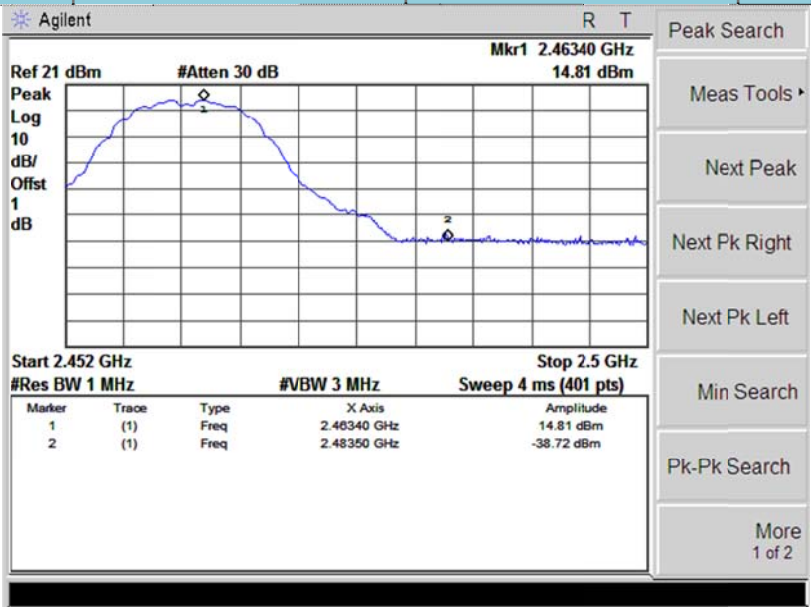

Peak

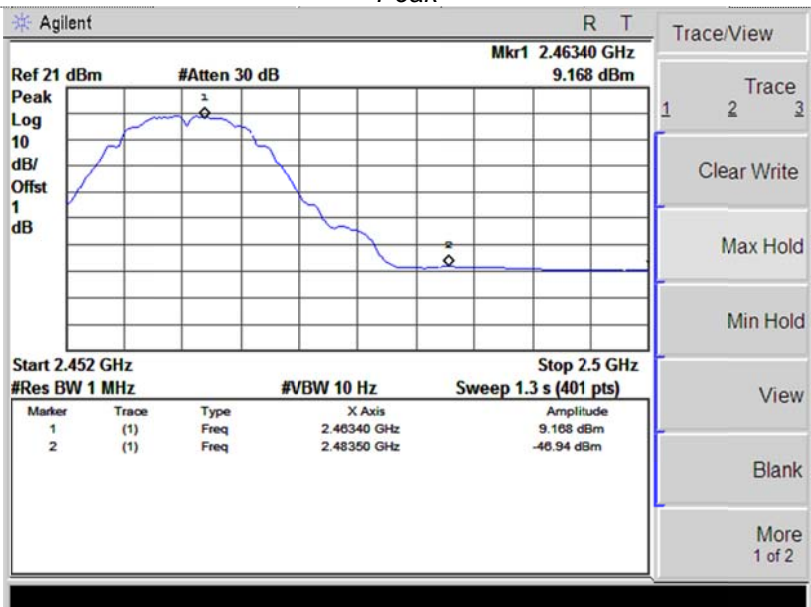

Average

Frequency (MHz)	Conducted Power (dBm)	Antenna Gain (dBi)	Ground Reflection Factor (dB)	Covert Radiated E Level at 3m (dBuV/m)	Detector	Limit (dBuV/m)	Result
2463.40	14.81	2.00	0.00	112.07	Peak		Pass
2483.50	-38.72	2.00	0.00	58.54	Peak	74.00	Pass
2463.40	9.168	2.00	0.00	106.428	Average		Pass
2483.50	-46.94	2.00	0.00	50.32	Average	54.00	Pass

Mode: 802.11g Test channel: 2412MHz

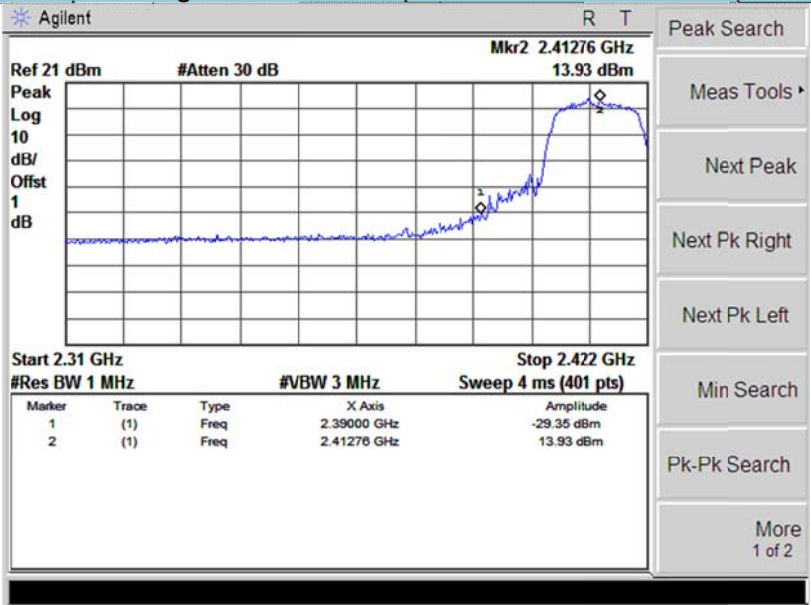

Peak

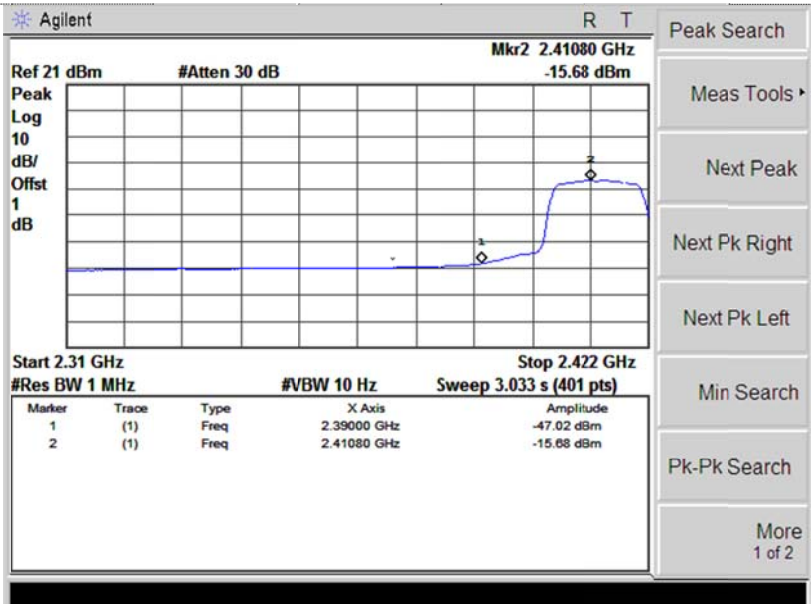

Average

Frequency (MHz)	Conducted Power (dBm)	Antenna Gain (dBi)	Ground Reflection Factor (dB)	Covert Radiated E Level at 3m (dBuV/m)	Detector	Limit (dBuV/m)	Result
2390.00	-29.35	2.00	0.00	67.91	Peak	74.00	Pass
2412.76	13.93	2.00	0.00	111.19	Peak		Pass
2390.00	-47.02	2.00	0.00	50.24	Average	54.00	Pass
2410.80	-15.68	2.00	0.00	81.58	Average		Pass

Mode: 802.11g Test channel: 2462MHz

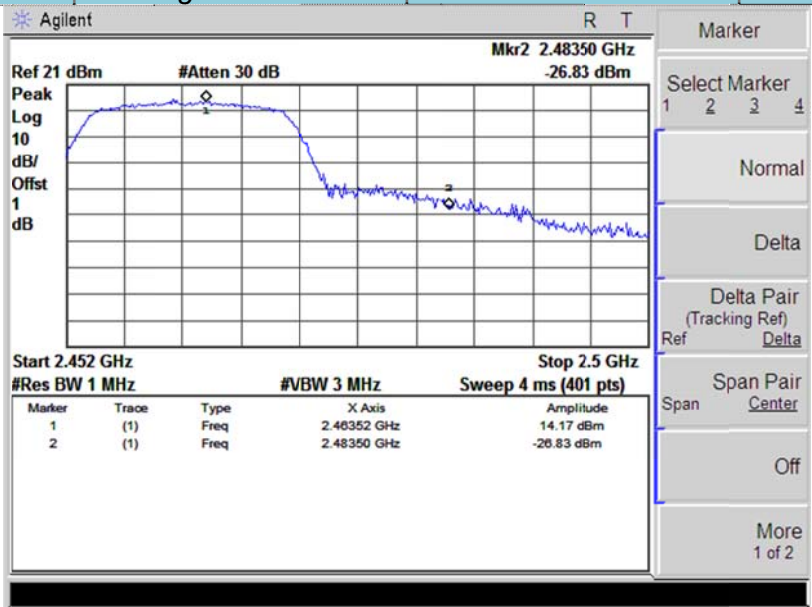

Peak

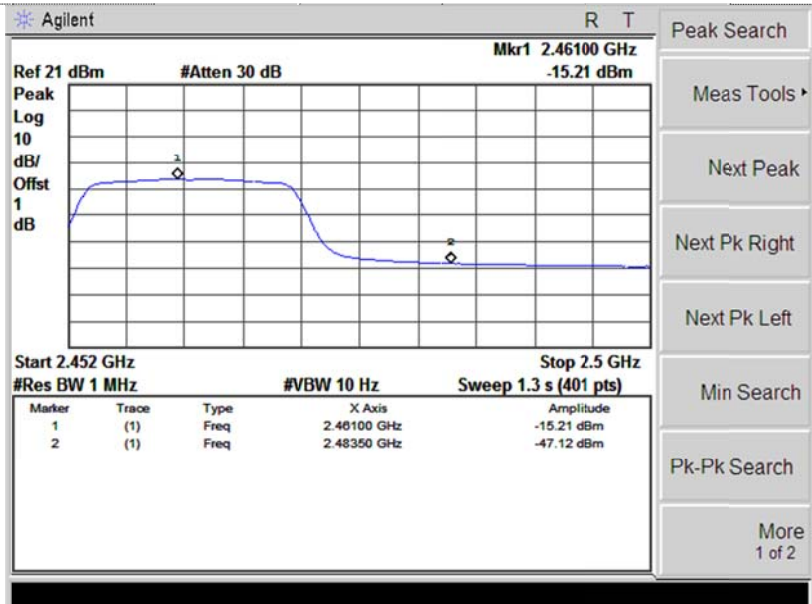

Average

Frequency (MHz)	Conducted Power (dBm)	Antenna Gain (dBi)	Ground Reflection Factor (dB)	Covert Radiated E Level at 3m (dBuV/m)	Detector	Limit (dBuV/m)	Result
2463.52	14.17	2.00	0.00	111.43	Peak		Pass
2483.50	-26.83	2.00	0.00	70.43	Peak	74.00	Pass
2461.00	-15.21	2.00	0.00	82.05	Average		Pass
2483.50	-47.12	2.00	0.00	50.14	Average	54.00	Pass

Mode: 802.11n(H20) Test channel: 2412MHz

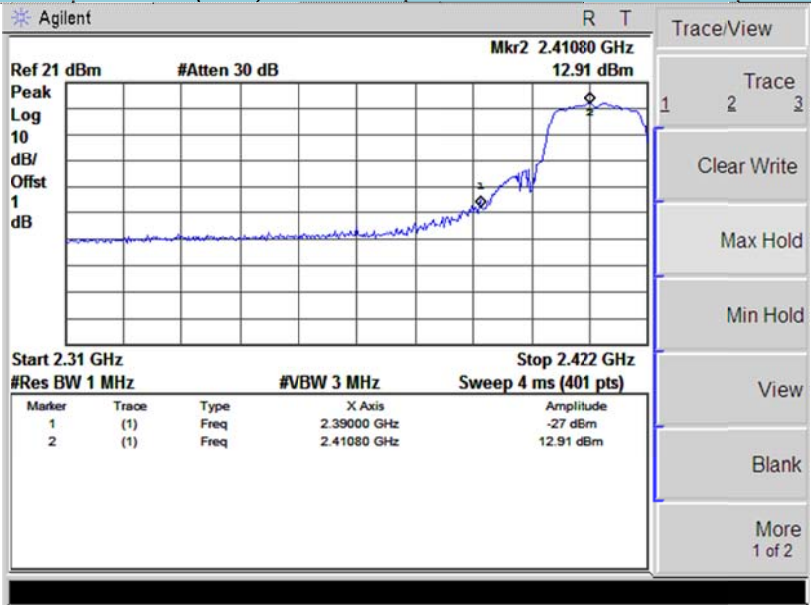

Peak

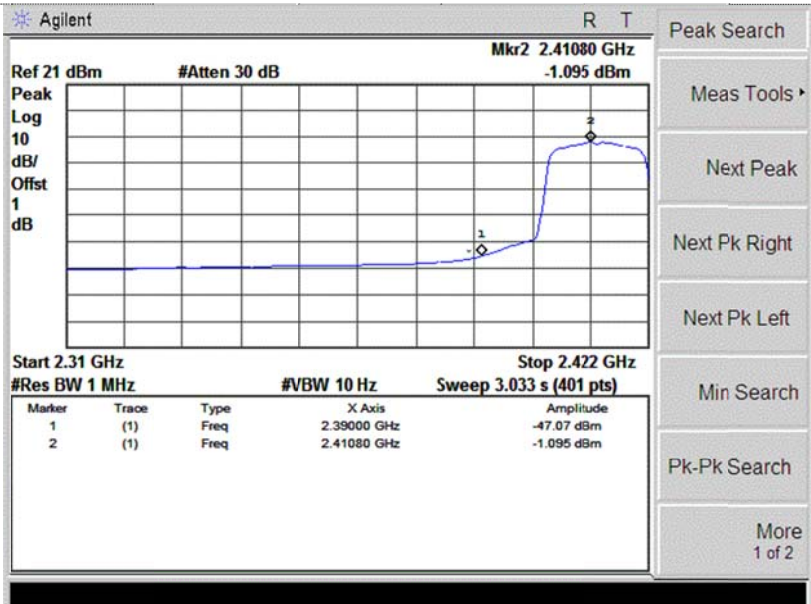

Average

Frequency (MHz)	Conducted Power (dBm)	Antenna Gain (dBi)	Ground Reflection Factor (dB)	Covert Radiated E Level at 3m (dBuV/m)	Detector	Limit (dBuV/m)	Result
2390.00	-27	2.00	0.00	70.26	Peak	74.00	Pass
2410.80	12.91	2.00	0.00	110.17	Peak		Pass
2390.00	-47.07	2.00	0.00	50.19	Average	54.00	Pass
2410.80	-1.095	2.00	0.00	96.165	Average		Pass

Mode: 802.11n(H20) Test channel: 2462MHz

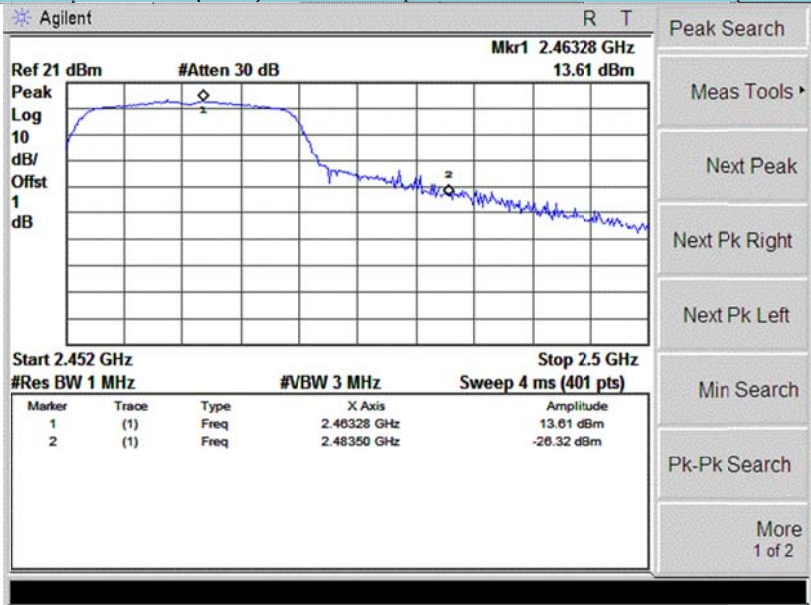

Peak

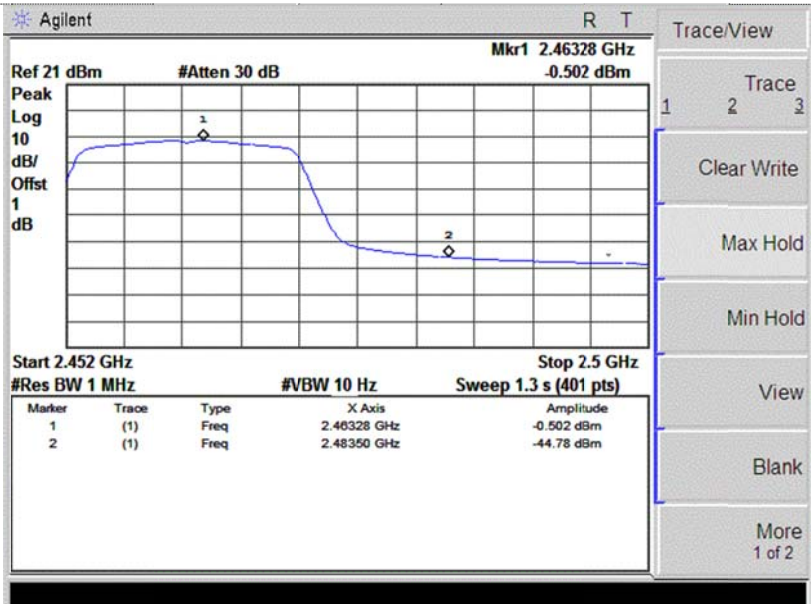

Average

Frequency (MHz)	Conducted Power (dBm)	Antenna Gain (dBi)	Ground Reflection Factor (dB)	Covert Radiated E Level at 3m (dBuV/m)	Detector	Limit (dBuV/m)	Result
2463.28	13.61	2.00	0.00	110.87	Peak		Pass
2483.50	-26.32	2.00	0.00	70.94	Peak	74.00	Pass
2463.28	-0.502	2.00	0.00	96.758	Average		Pass
2483.50	-44.78	2.00	0.00	52.48	Average	54.00	Pass

Mode: 802.11n(H40) Test channel: 2422MHz

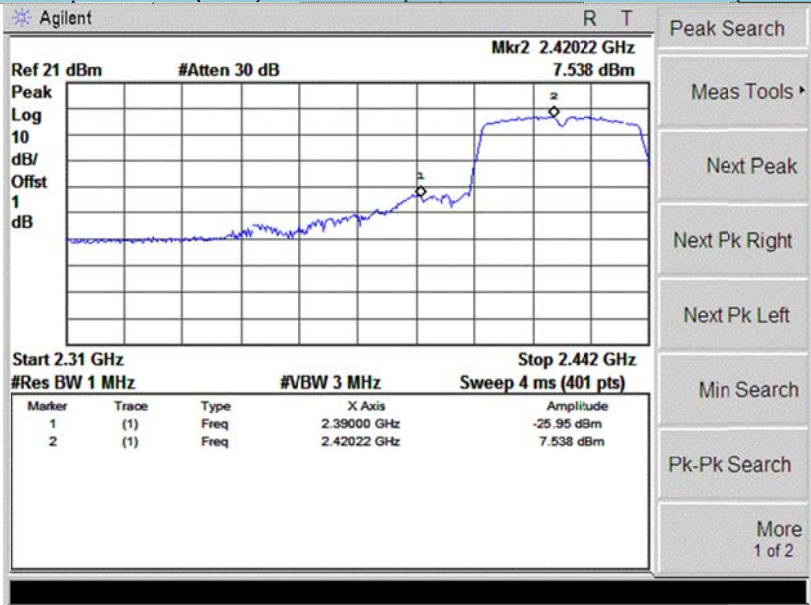

Peak

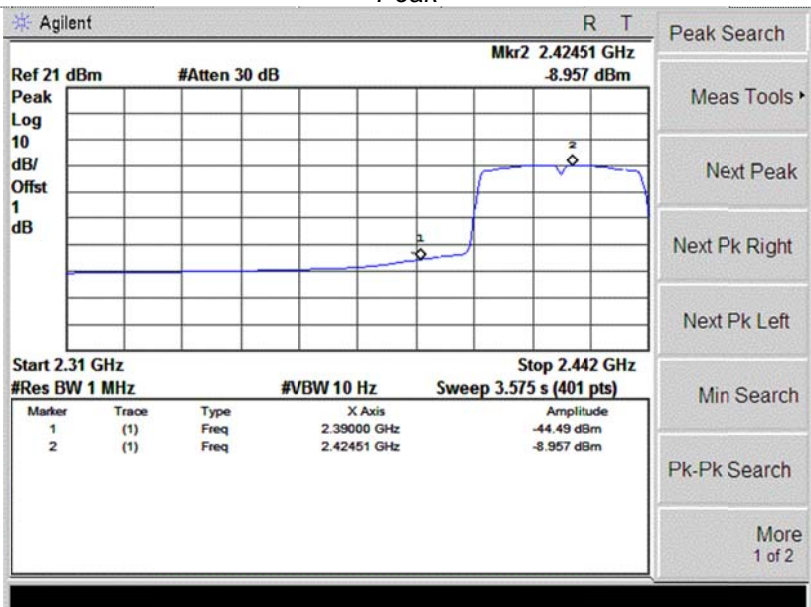

Average

Frequency (MHz)	Conducted Power (dBm)	Antenna Gain (dBi)	Ground Reflection Factor (dB)	Covert Radiated E Level at 3m (dBuV/m)	Detector	Limit (dBuV/m)	Result
2390.00	-25.95	2.00	0.00	71.31	Peak	74.00	Pass
2420.22	7.53	2.00	0.00	104.79	Peak	74.00	Pass
2390.00	-44.49	2.00	0.00	52.77	Average	54.00	Pass
2424.51	-8.95	2.00	0.00	88.31	Average	54.00	Pass

Mode: 802.11n(H40) Test channel: 2452MHz

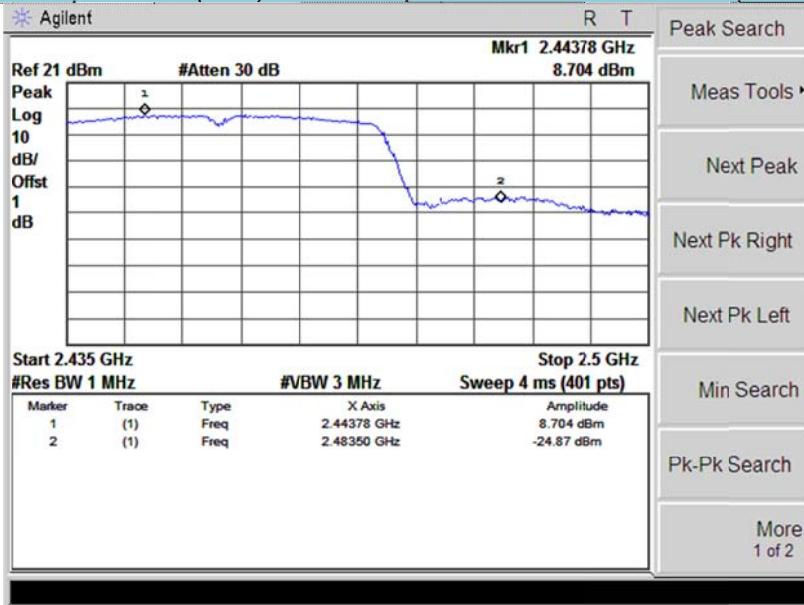

Peak

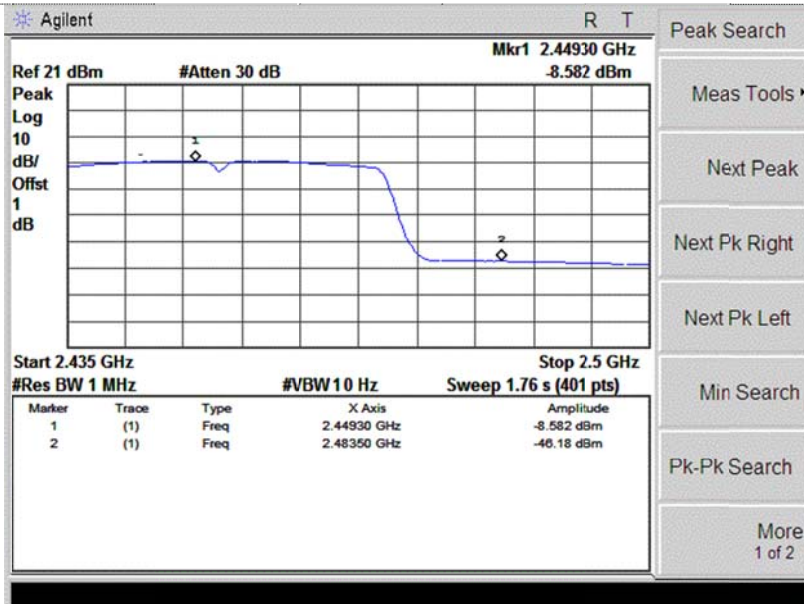

Average

Frequency (MHz)	Conducted Power (dBm)	Antenna Gain (dBi)	Ground Reflection Factor (dB)	Covert Radiated E Level at 3m (dBuV/m)	Detector	Limit (dBuV/m)	Result
2443.78	8.70	2.00	0.00	105.96	Peak		Pass
2483.50	-24.87	2.00	0.00	72.39	Peak	74.00	Pass
2449.30	-8.58	2.00	0.00	88.67	Average		Pass
2483.50	-46.18	2.00	0.00	51.08	Average	54.00	Pass



## 4.7. Spurious Emission (conducted)

### LIMIT

FCC CFR Title 47 Part 15 Subpart C Section 15.247 (d):

*In any 100 kHz bandwidth outside the frequency band in which the spread spectrum intentional radiator is operating, the radio frequency power that is produced by the intentional radiator shall be at least 20 dB below that in the 100 kHz bandwidth within the band that contains the highest level of the desired power, based on either an RF conducted or a radiated measurement.*

### TEST CONFIGURATION



### TEST PROCEDURE

1. The transmitter output was connected to the spectrum analyzer through an attenuator.
2. The bandwidth of the fundamental frequency was measured by spectrum analyzer with RBW=100 KHz and VBW=300KHz, scan up through 10th harmonic

### TEST RESULTS

Test plot as follows:

802.11b

Test channel

2412MHz

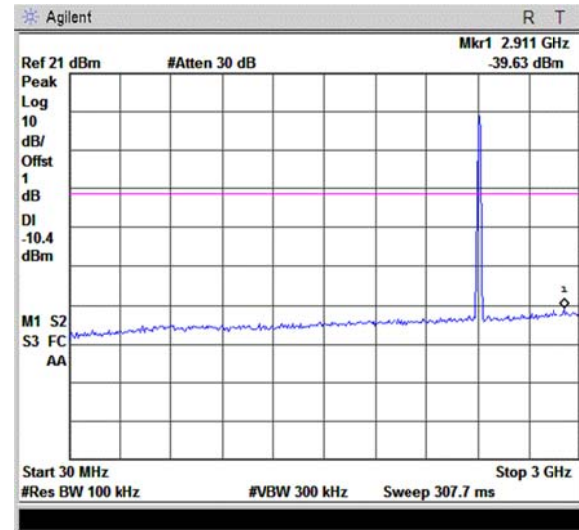

30MHz~3GHz

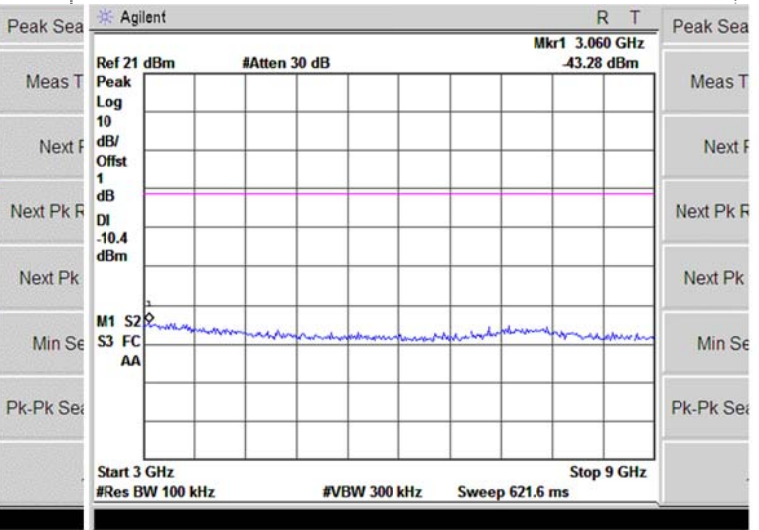

3GHz~9GHz

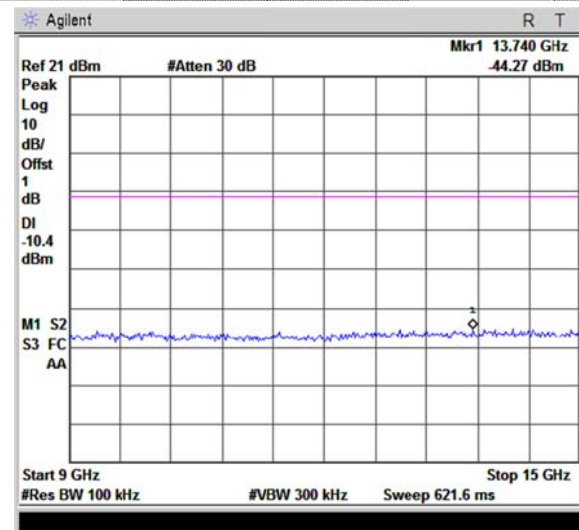

9GHz~15GHz

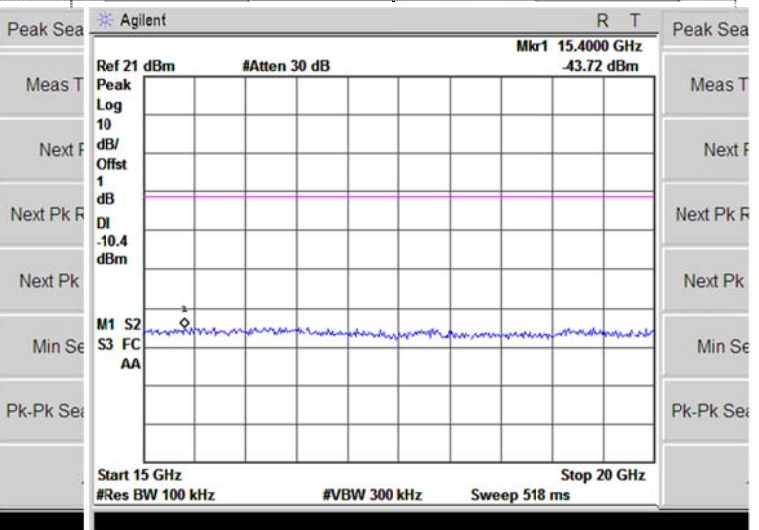

15GHz~20GHz

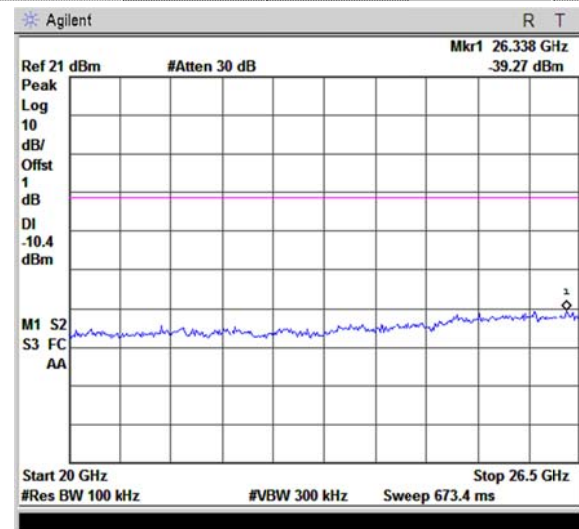

20GHz~26.5GHz

Test channel

2437MHz

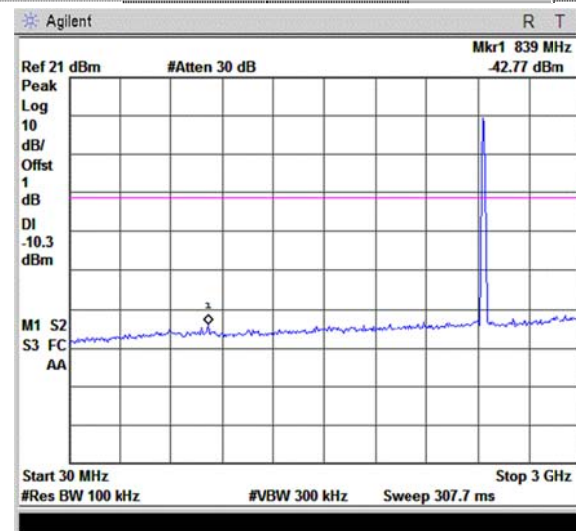

30MHz~3GHz

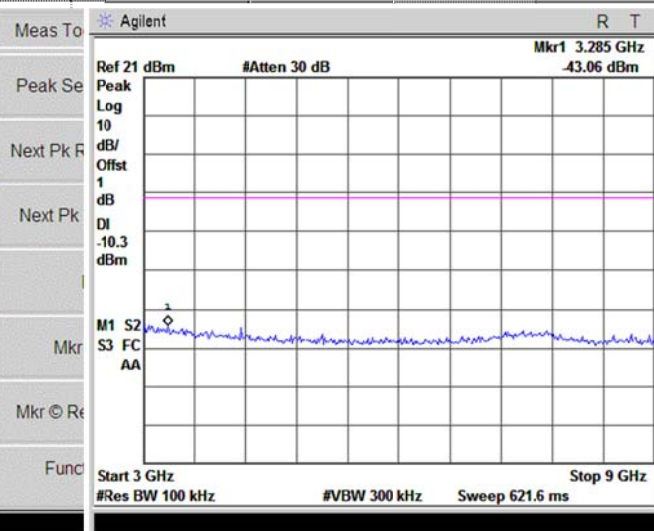

3GHz~9GHz

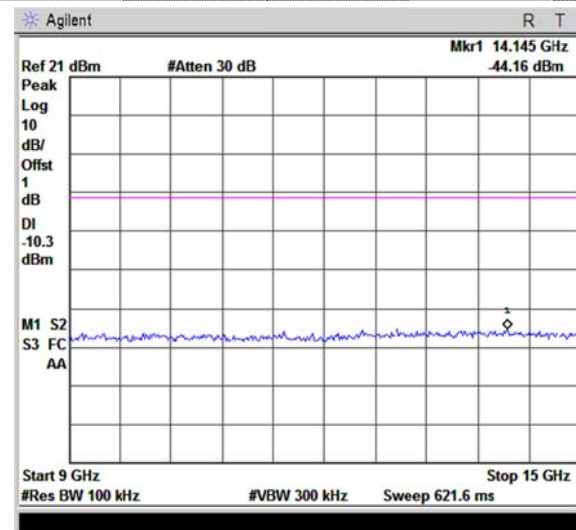

9GHz~15GHz

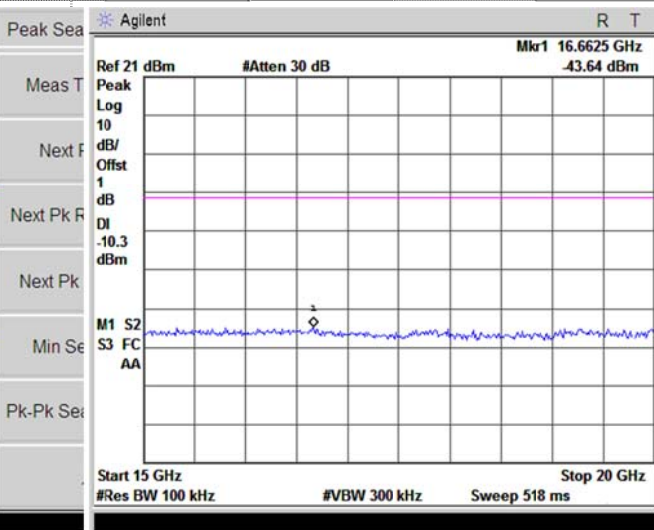

15GHz~20GHz

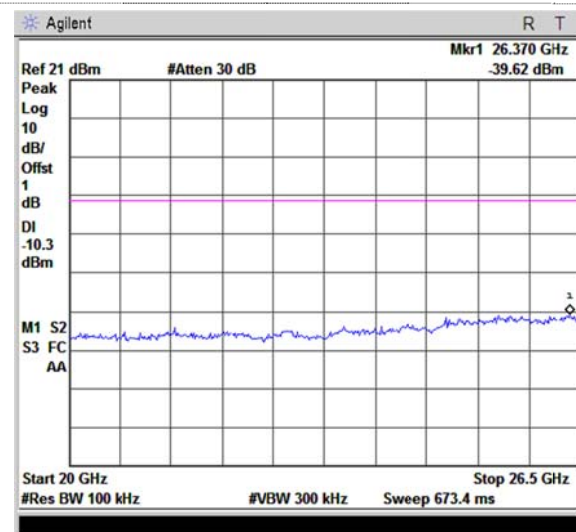

20GHz~26.5GHz

Test channel

2462MHz

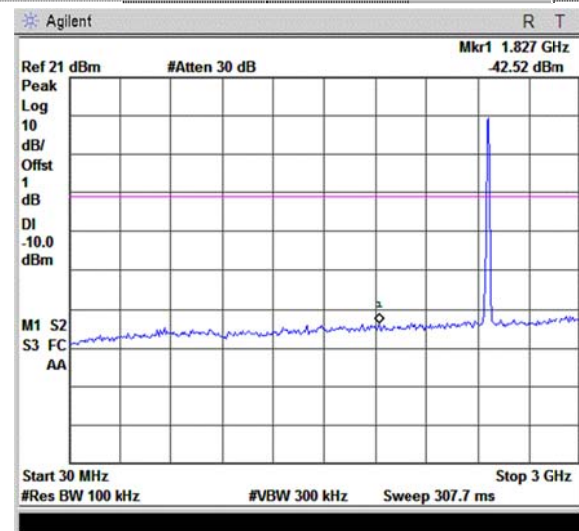

30MHz~3GHz

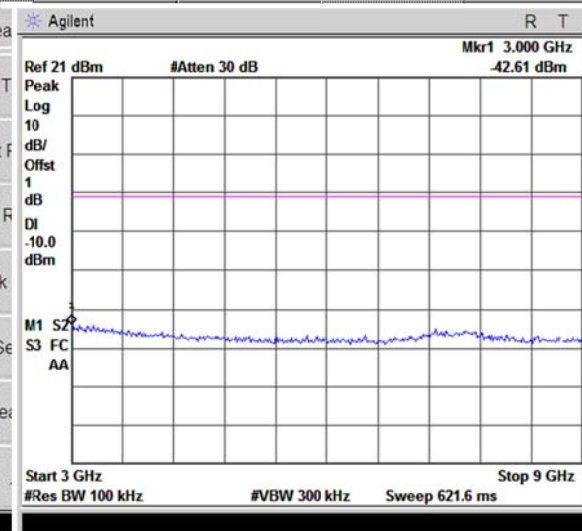

3GHz~9GHz

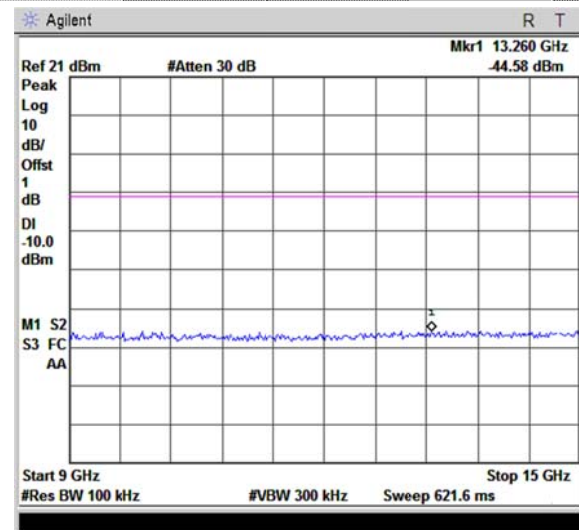

9GHz~15GHz

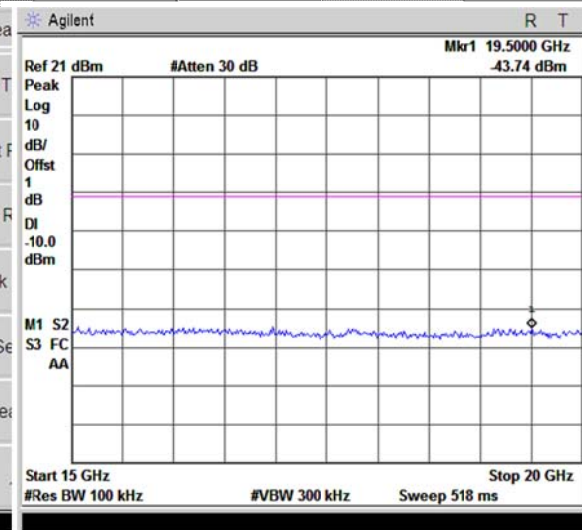

15GHz~20GHz

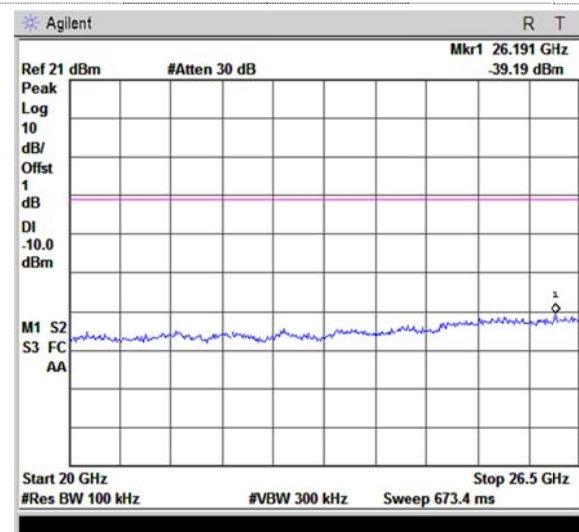

20GHz~26.5GHz

802.11g

Test channel

2412MHz

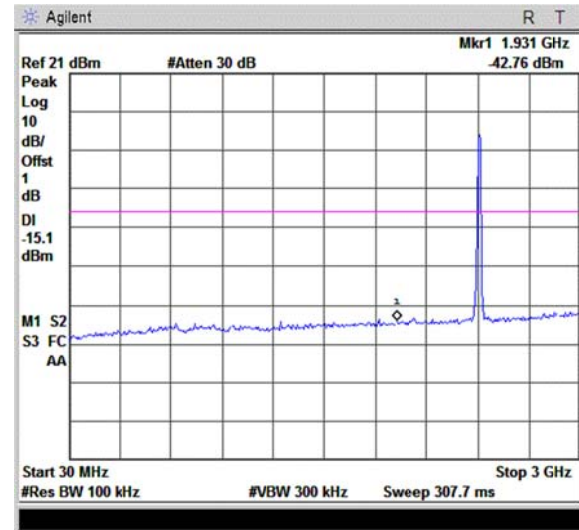

30MHz~3GHz

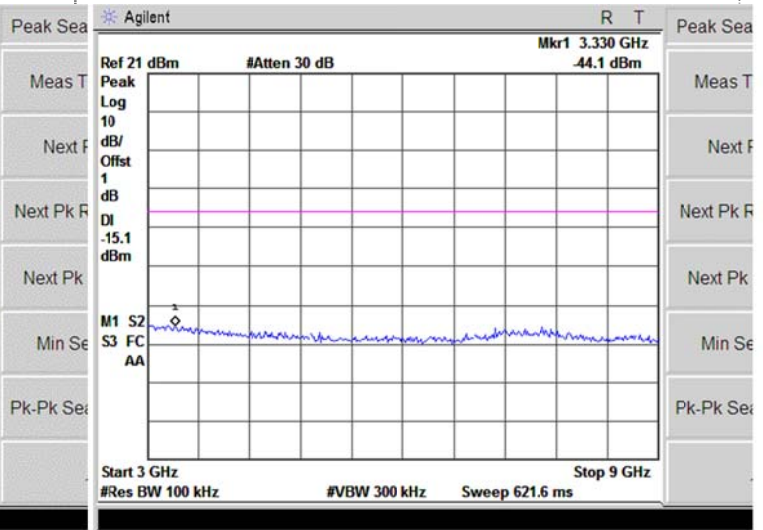

3GHz~9GHz

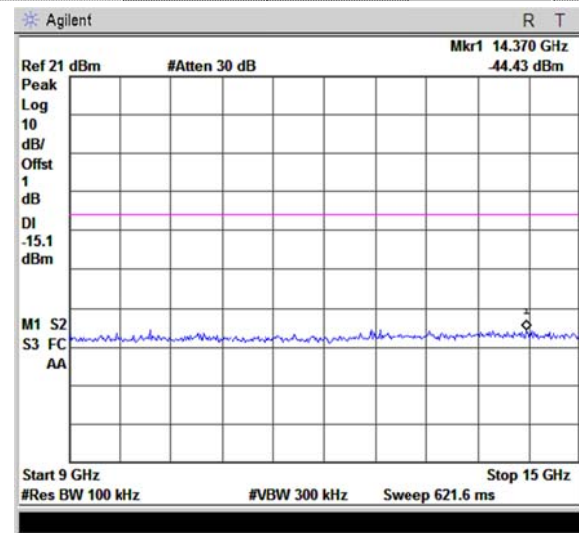

9GHz~15GHz

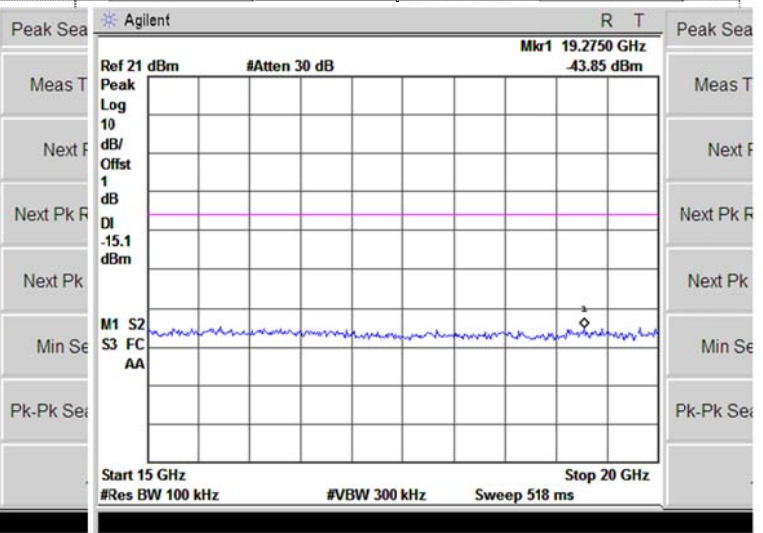

15GHz~20GHz

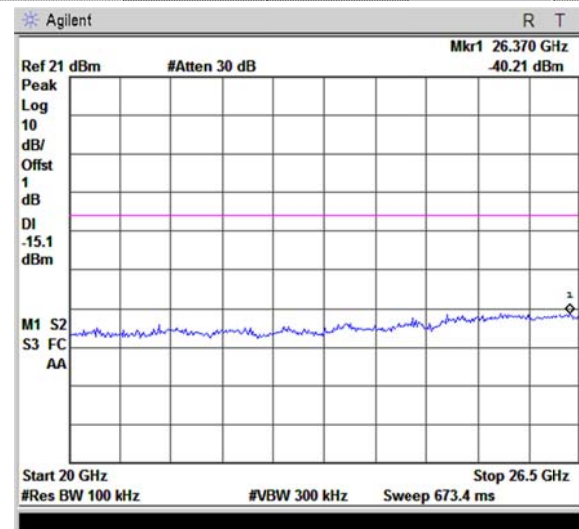

20GHz~26.5GHz

Test channel

2437MHz

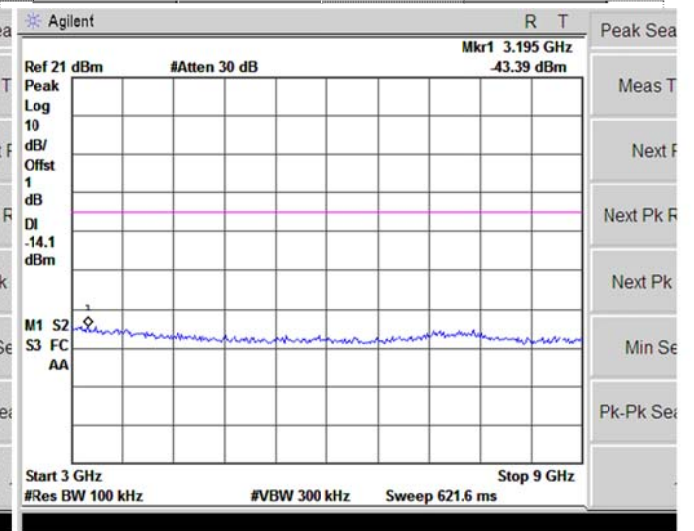
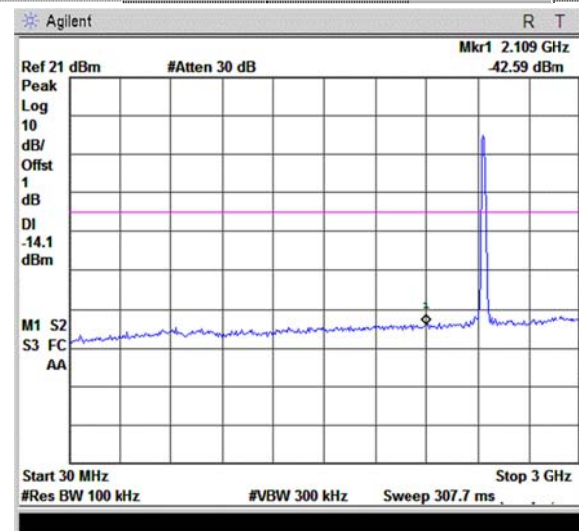

30MHz~3GHz

3GHz~9GHz

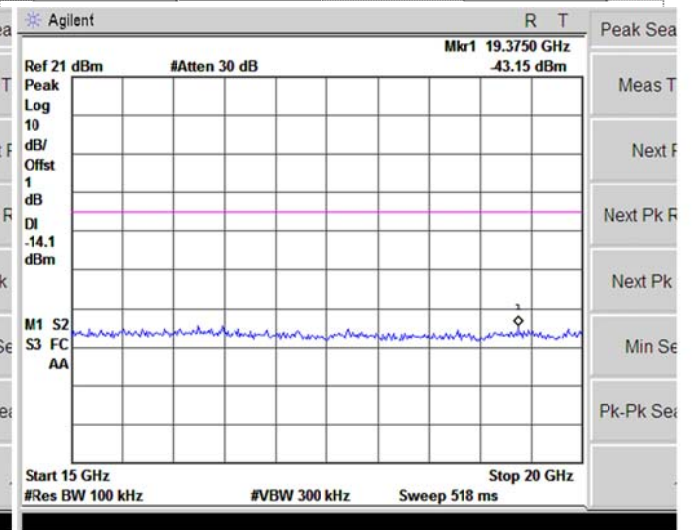
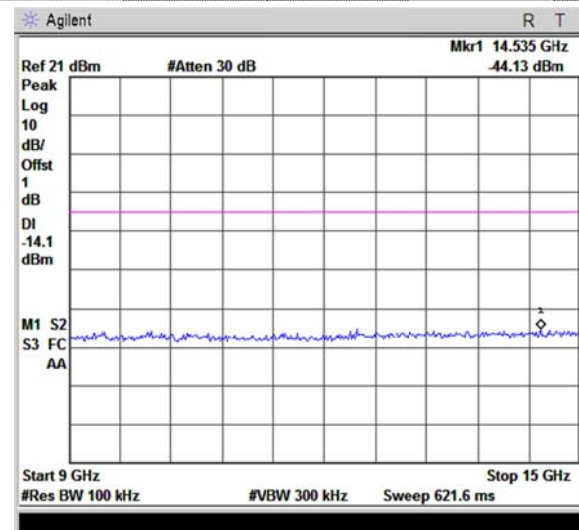

9GHz~15GHz

15GHz~20GHz

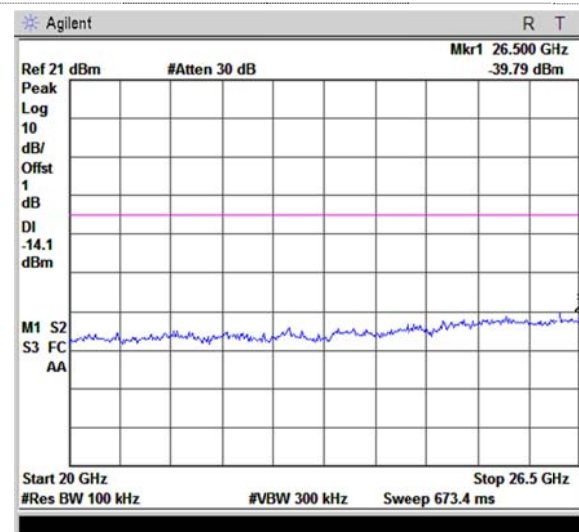

20GHz~26.5GHz

Test channel

2462MHz

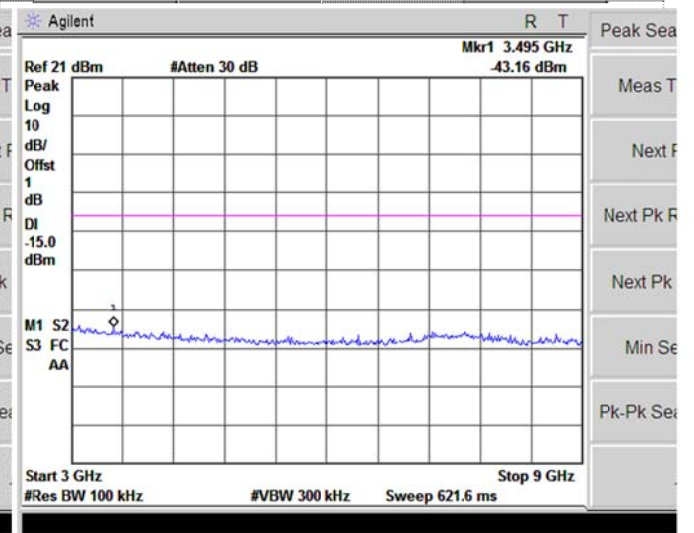
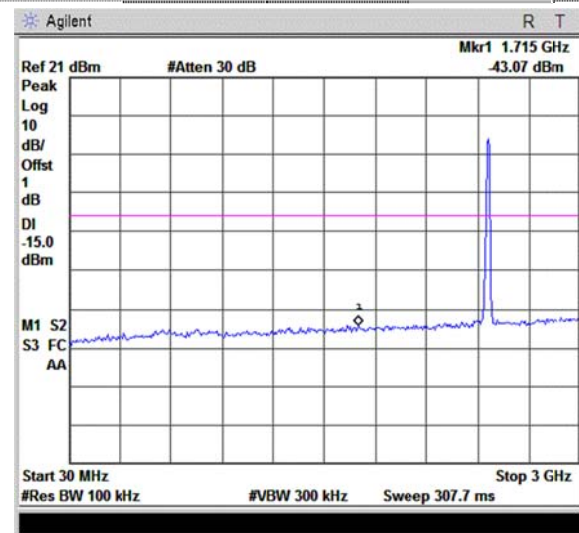

30MHz~3GHz

3GHz~9GHz

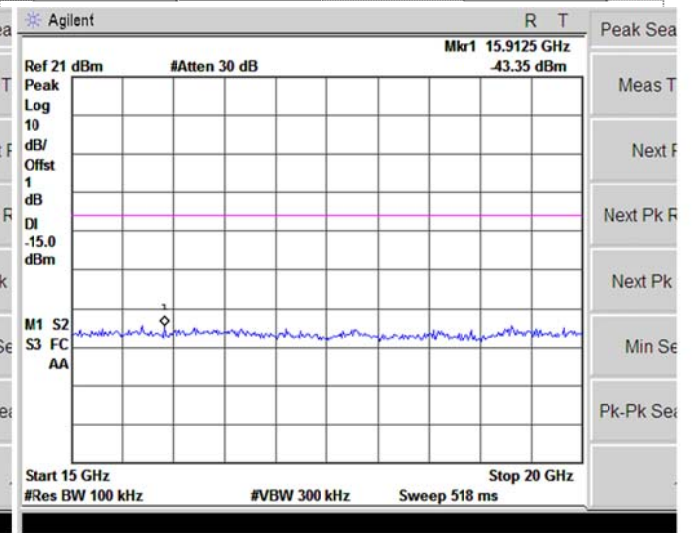
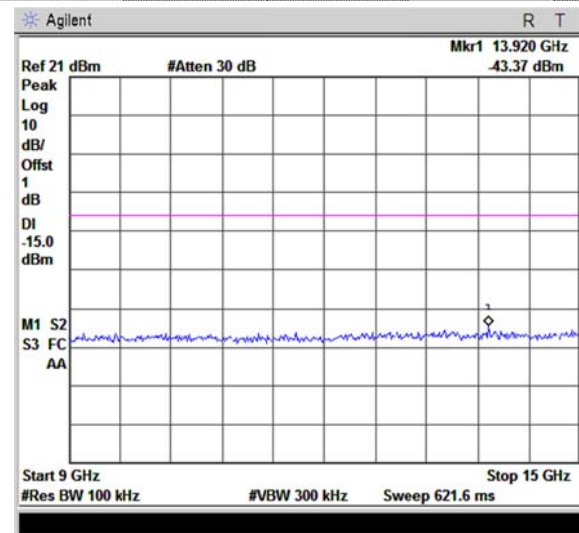

9GHz~15GHz

15GHz~20GHz

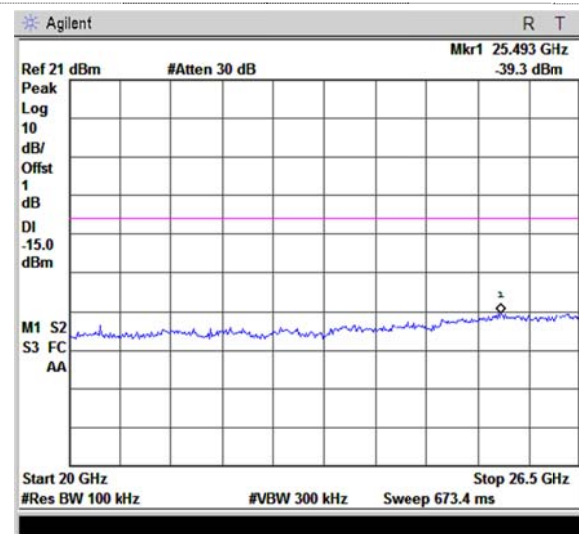

20GHz~26.5GHz

802.11n(H20)

Test channel

2412MHz

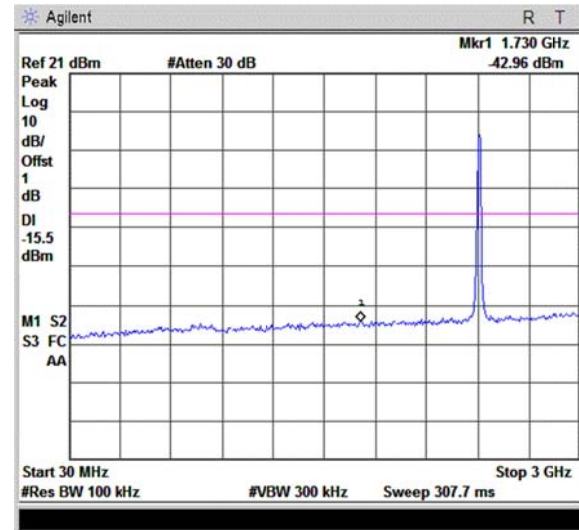

30MHz~3GHz

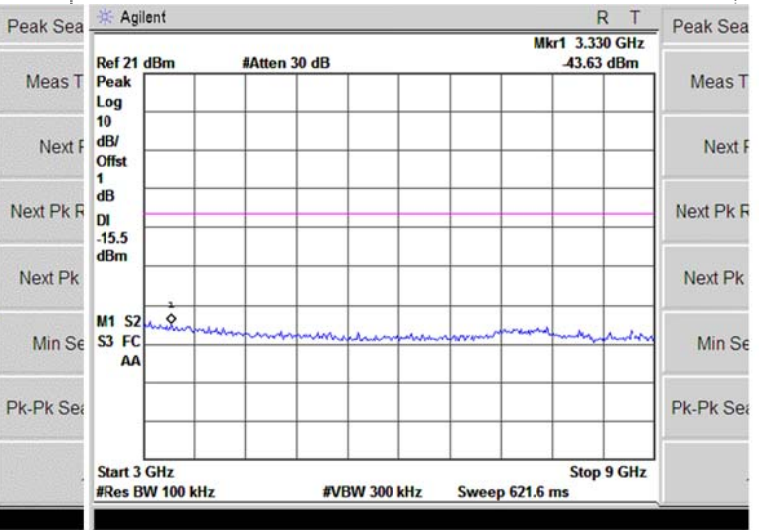

3GHz~9GHz

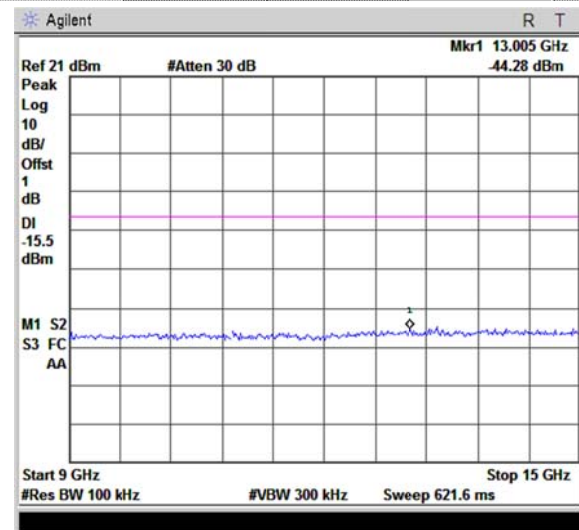

9GHz~15GHz

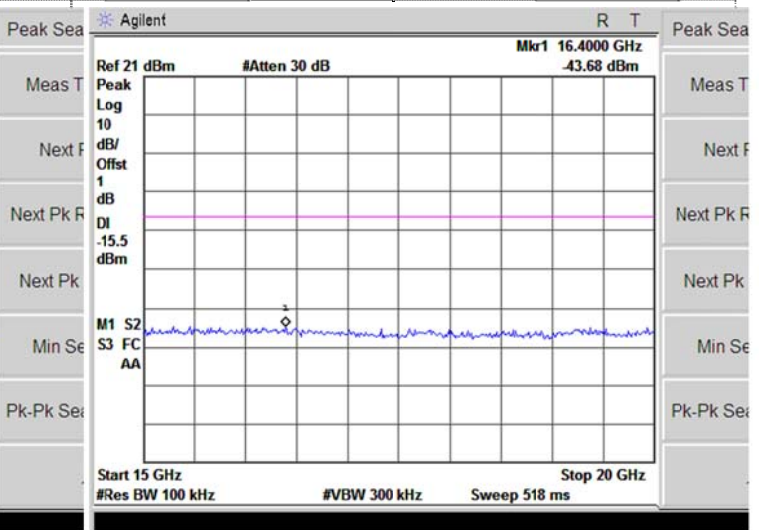

15GHz~20GHz

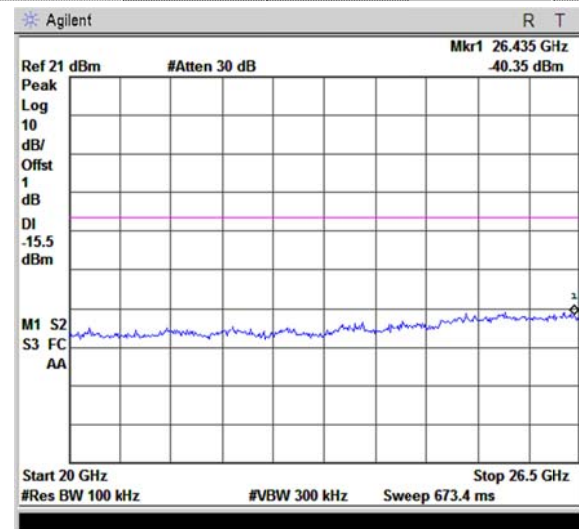

20GHz~26.5GHz



Test channel

2437MHz

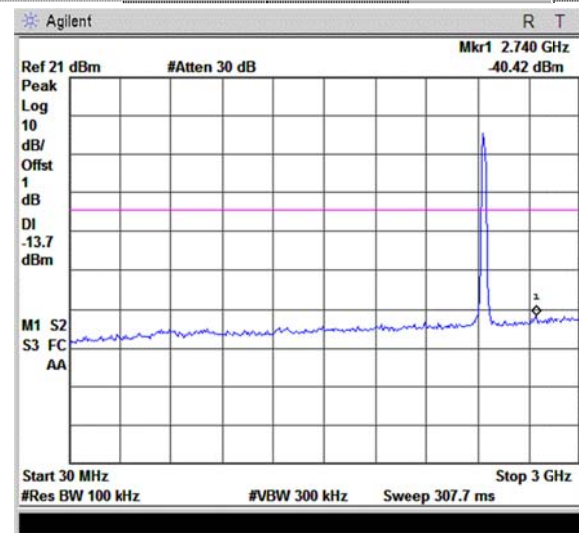

30MHz~3GHz

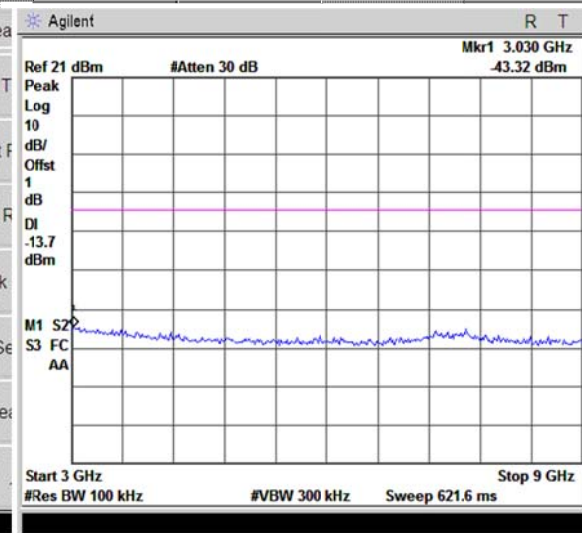

3GHz~9GHz

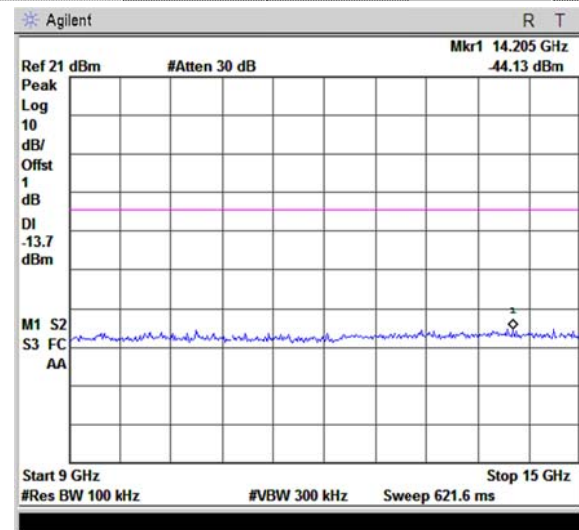

9GHz~15GHz

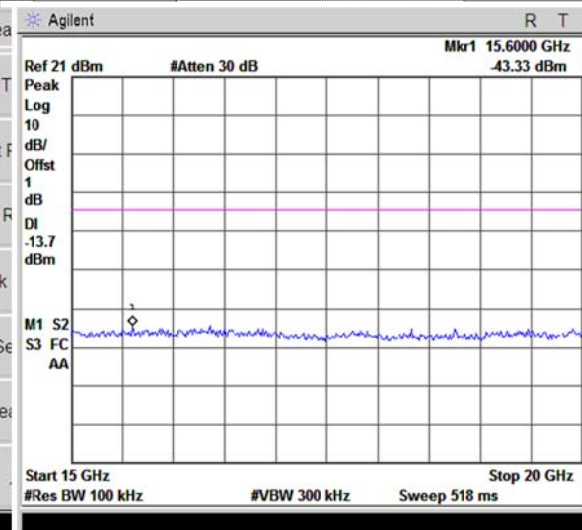

15GHz~20GHz

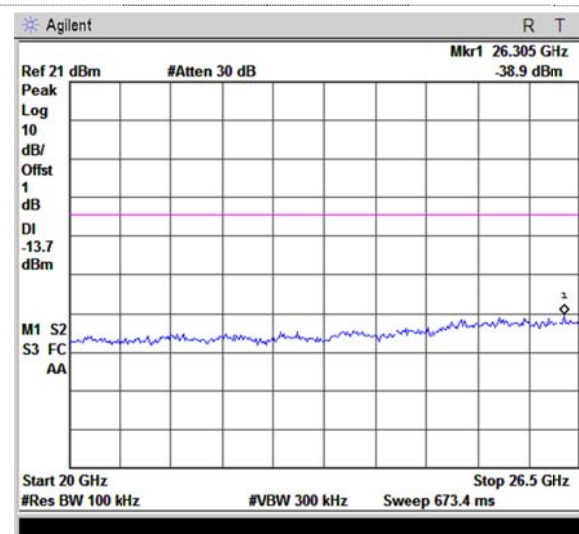

20GHz~26.5GHz

Test channel

2462MHz

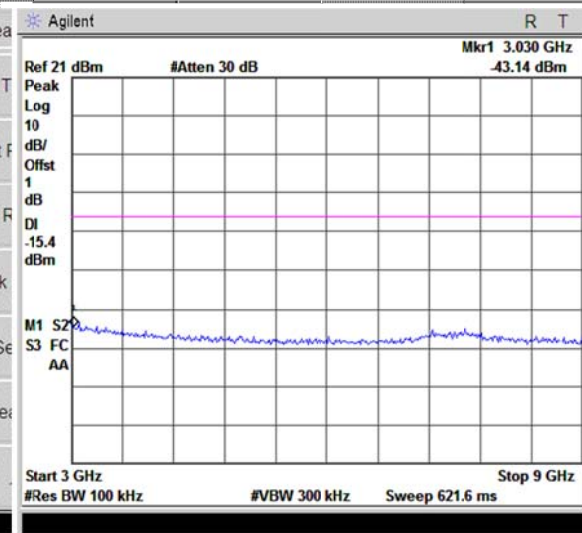
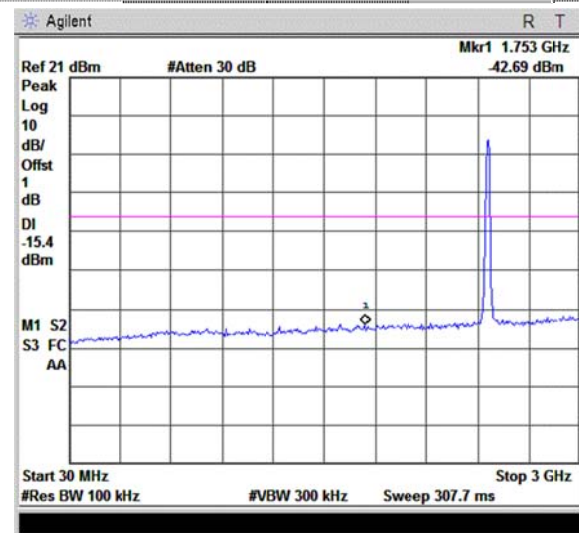

30MHz~3GHz

3GHz~9GHz

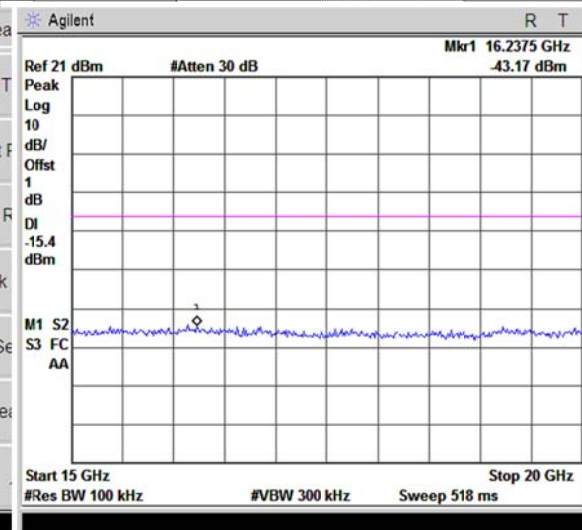
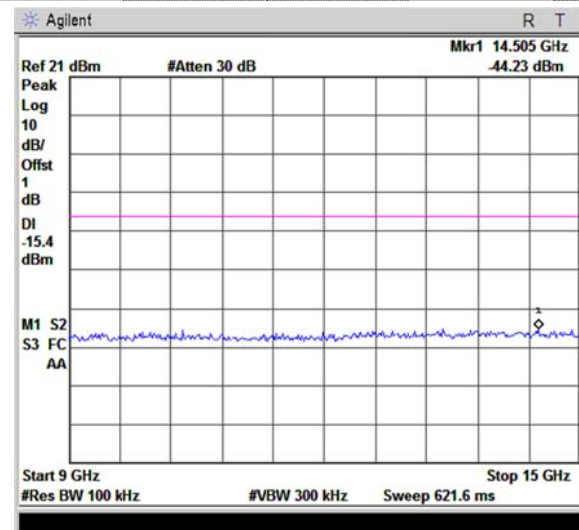

9GHz~15GHz

15GHz~20GHz

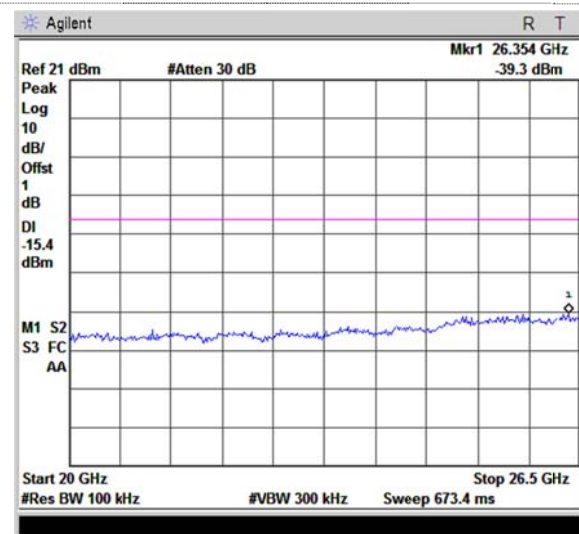

20GHz~26.5GHz

802.11n(H40)

Test channel

2422MHz

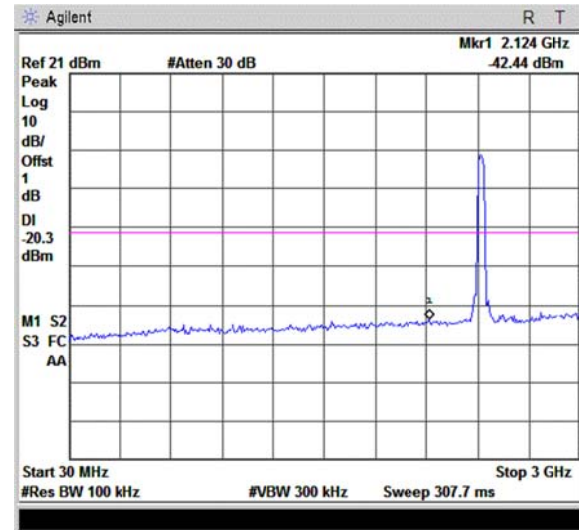

30MHz~3GHz

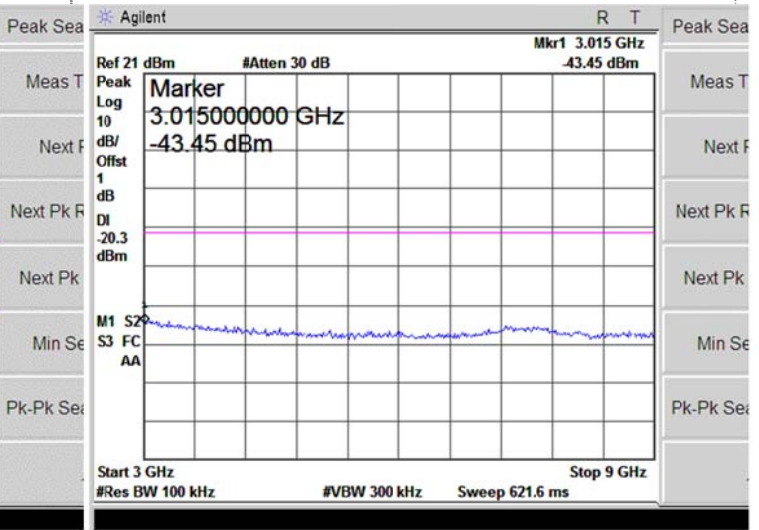

3GHz~9GHz

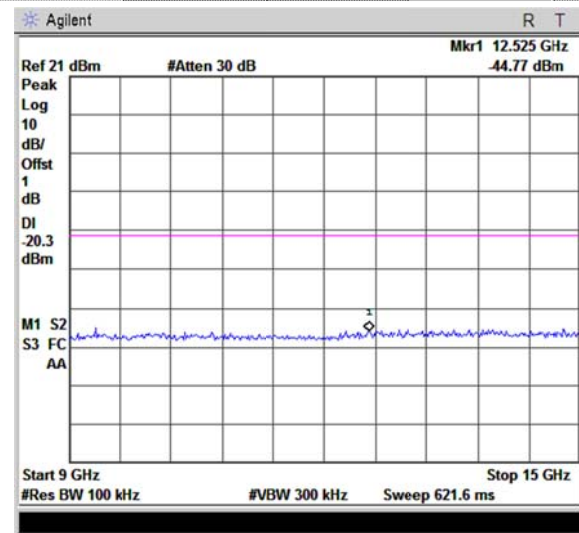

9GHz~15GHz

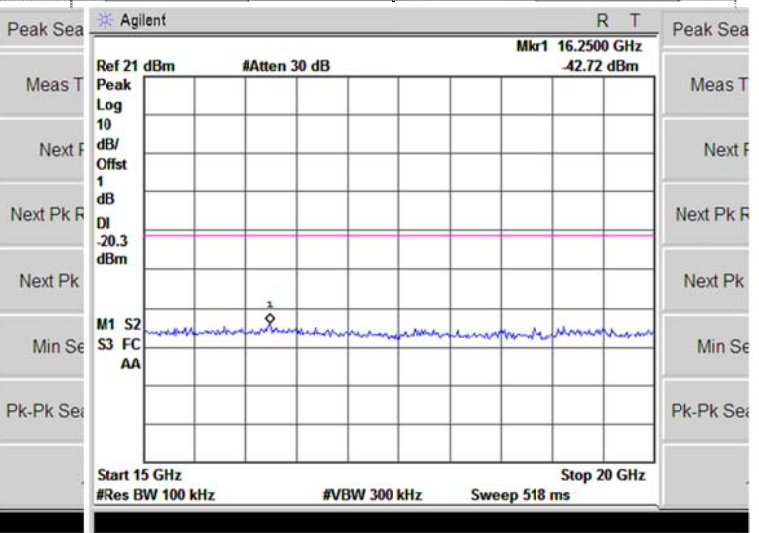

15GHz~20GHz

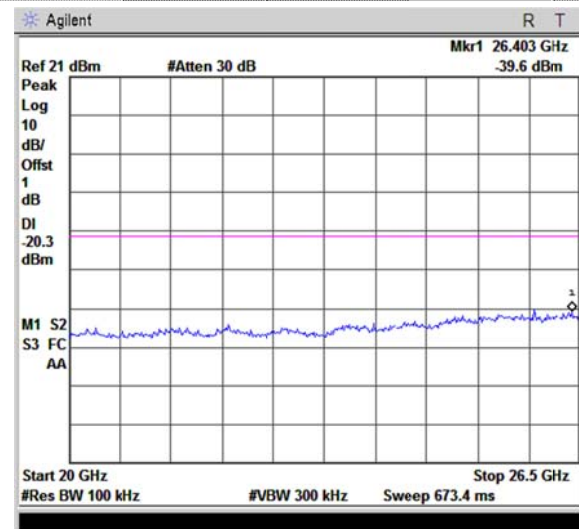

20GHz~26.5GHz

Test channel

2437MHz

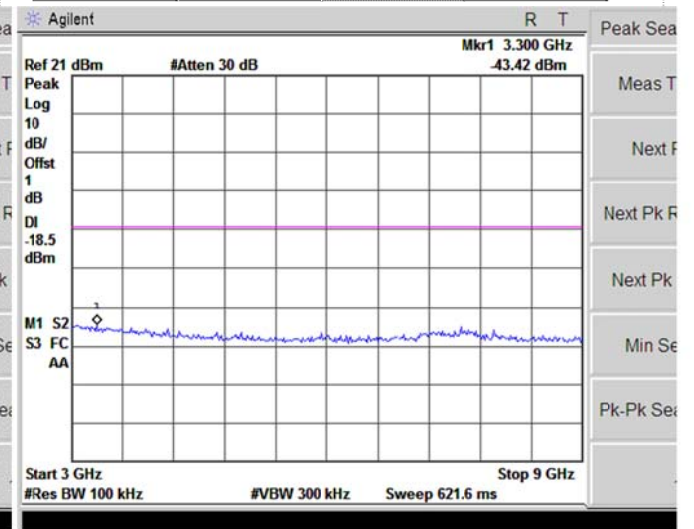
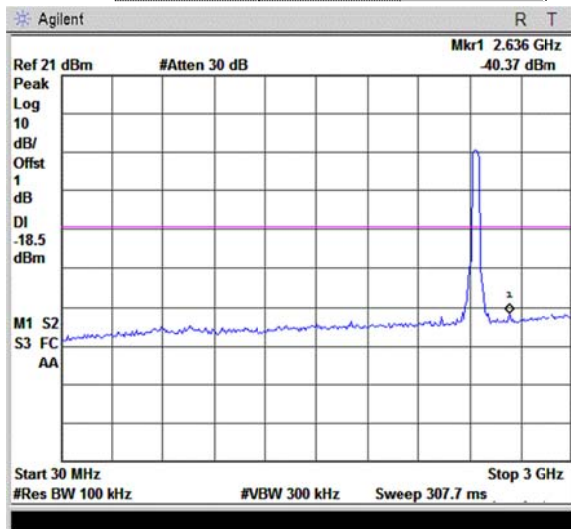

30MHz~3GHz

3GHz~9GHz

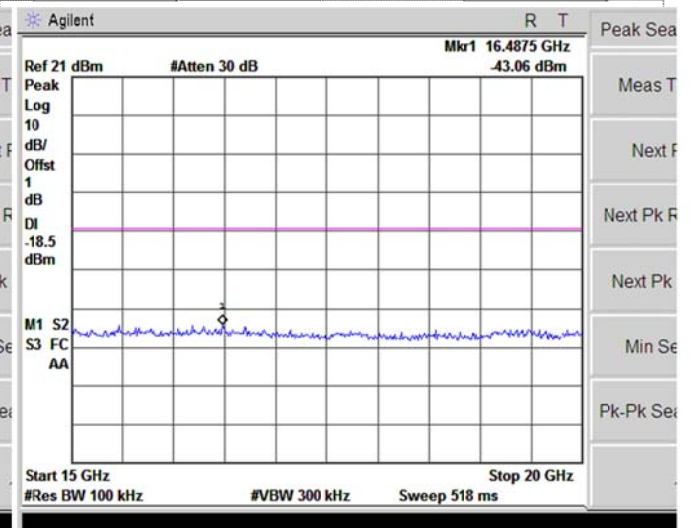
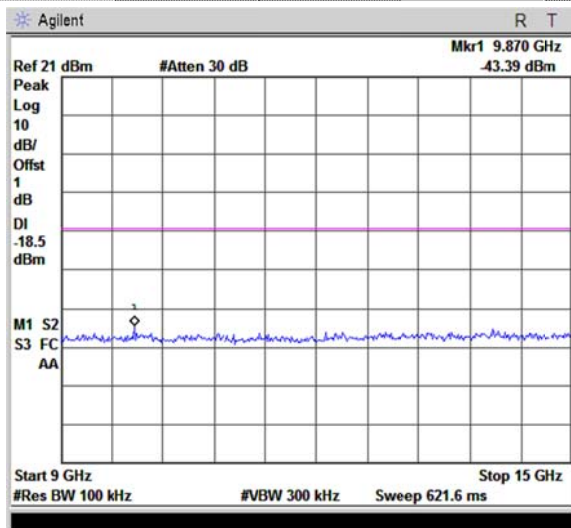

9GHz~15GHz

15GHz~20GHz

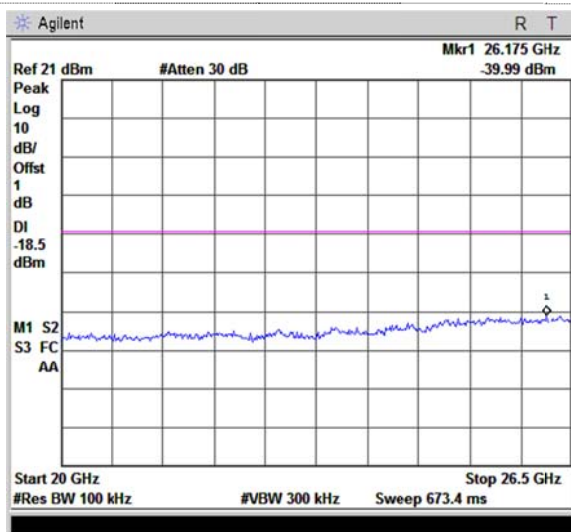

20GHz~26.5GHz

Test channel

2452MHz

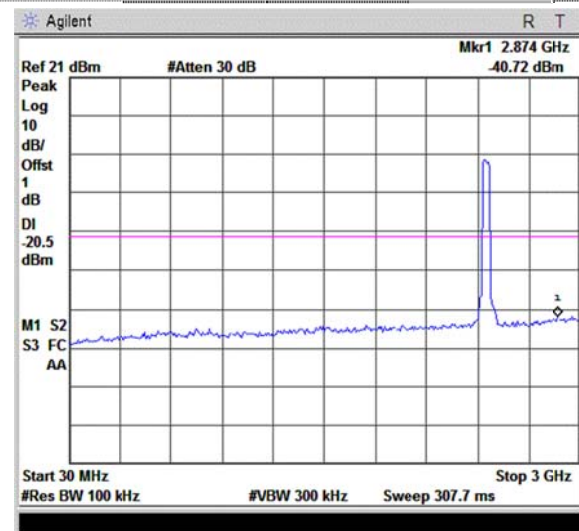

30MHz~3GHz

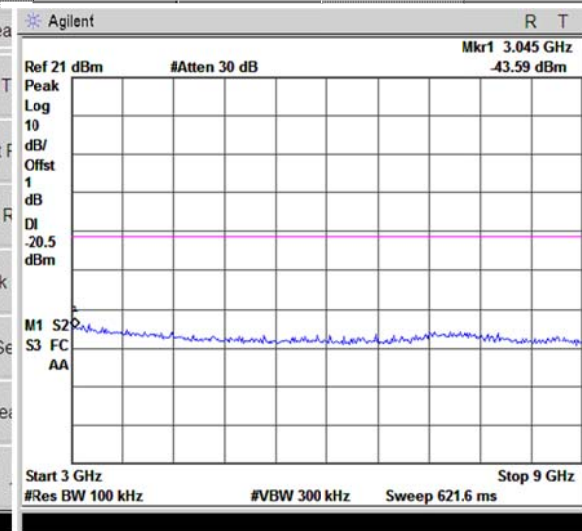

3GHz~9GHz

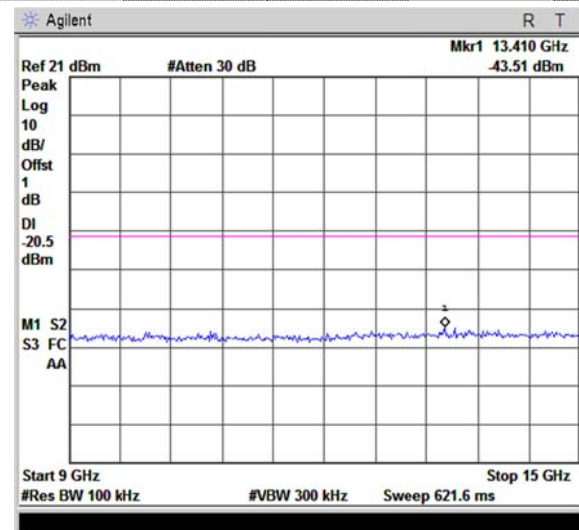

9GHz~15GHz

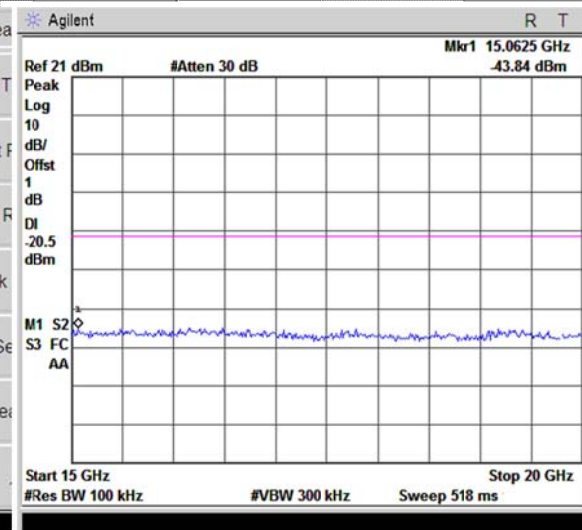

15GHz~20GHz

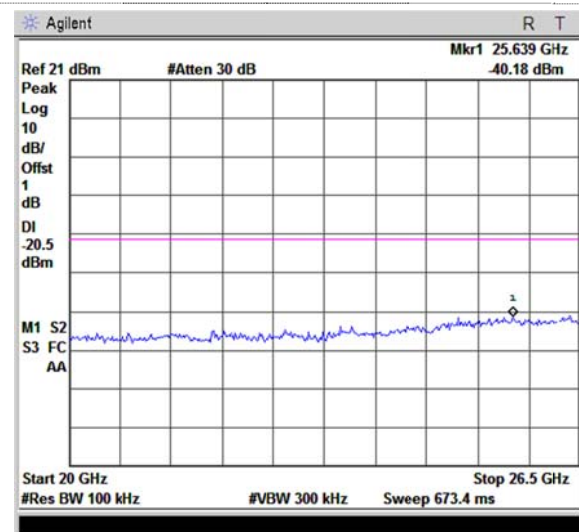

20GHz~26.5GHz

## 4.8. Spurious Emission (radiated)

### LIMIT

FCC CFR Title 47 Part 15 Subpart C Section 15.209

Frequency	Limit (dBuV/m @3m)	Value
30MHz-88MHz	40.00	Quasi-peak
88MHz-216MHz	43.50	Quasi-peak
216MHz-960MHz	46.00	Quasi-peak
960MHz-1GHz	54.00	Quasi-peak
Above 1GHz	54.00	Average
	74.00	Peak

### TEST CONFIGURATION

- Below 1GHz

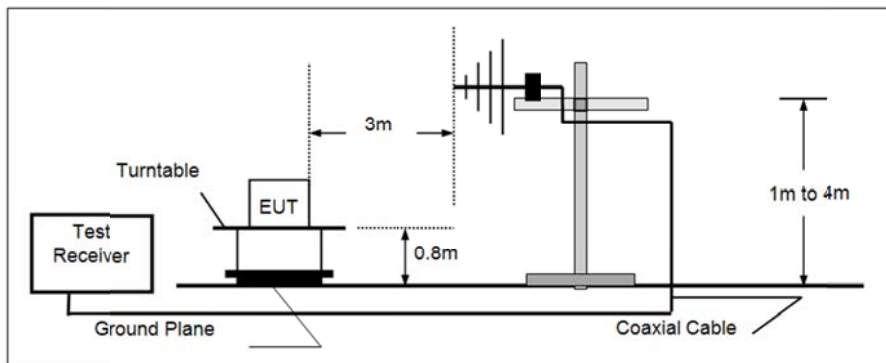

- Above 1GHz

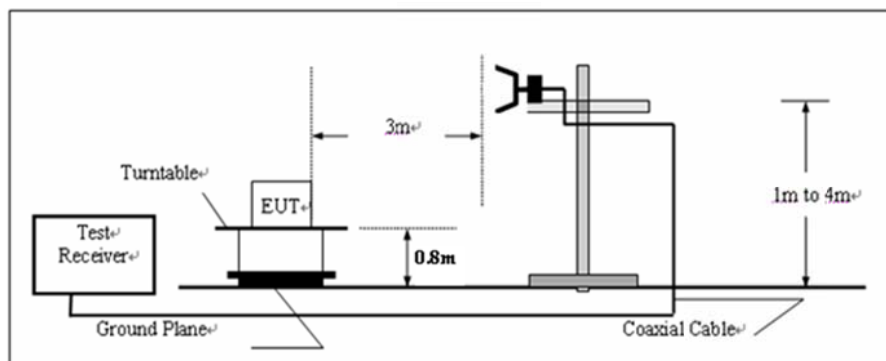

### TEST PROCEDURE

1. The EUT was setup according to ANSI C63.4: 2009 and tested according to ANSI C63.10:2009 for compliance to FCC 47CFR 15.247 requirements.
2. The EUT is placed on a turn table which is 0.8 meter above ground. The turn table is rotated 360 degrees to determine the position of the maximum emission level.
3. The EUT was positioned such that the distance from antenna to the EUT was 3 meters.
4. The antenna is scanned from 1 meter to 4 meters to find out the maximum emission level. This is repeated for both horizontal and vertical polarization of the antenna. In order to find the maximum emission, all of the interface cables were manipulated according to ANSI C63.4:2009 on radiated measurement.
5. The resolution bandwidth below 1GHz setting on the field strength meter is 120 kHz and above 1GHz is 1MHz.
6. For Frequencies below 1 GHz, RBW= 120 kHz, testing was performed with CISPR16 compliant test receiver with QP detector. Above 1 GHz tests were performed using a spectrum analyser using the following settings:  
Peak RBW=VBW= 1MHz  
Average RBW 1MHz , VBW=10Hz
7. These settings as per ANSI C63.10

**TEST RESULTS**

*Noted:*

*Have pre-scan all modulation mode, found the GFSK modulation which it was worst case, so only the worst case's data on the test report.*

***For 9KHz to 30MHz***

Frequency (MHz)	Level (dBuV/m)@3m	Limit Line (dBuV/m)@3m	Margin (dB)	Detector	Result
13.37	42.34	69.54	-24.2	QP	PASS
24.38	41.66	69.54	-27.88	QP	PASS

Measurement data:

■ Below 1GHz

**SWEEP TABLE: "test (30M-1G)"**

Short Description:		Field Strength			
Start	Stop	Detector	Meas. Time	IF Bandw.	Transducer
30.0 MHz	1.1 GHz	MaxPeak	Coupled	100 kHz	VULB9163

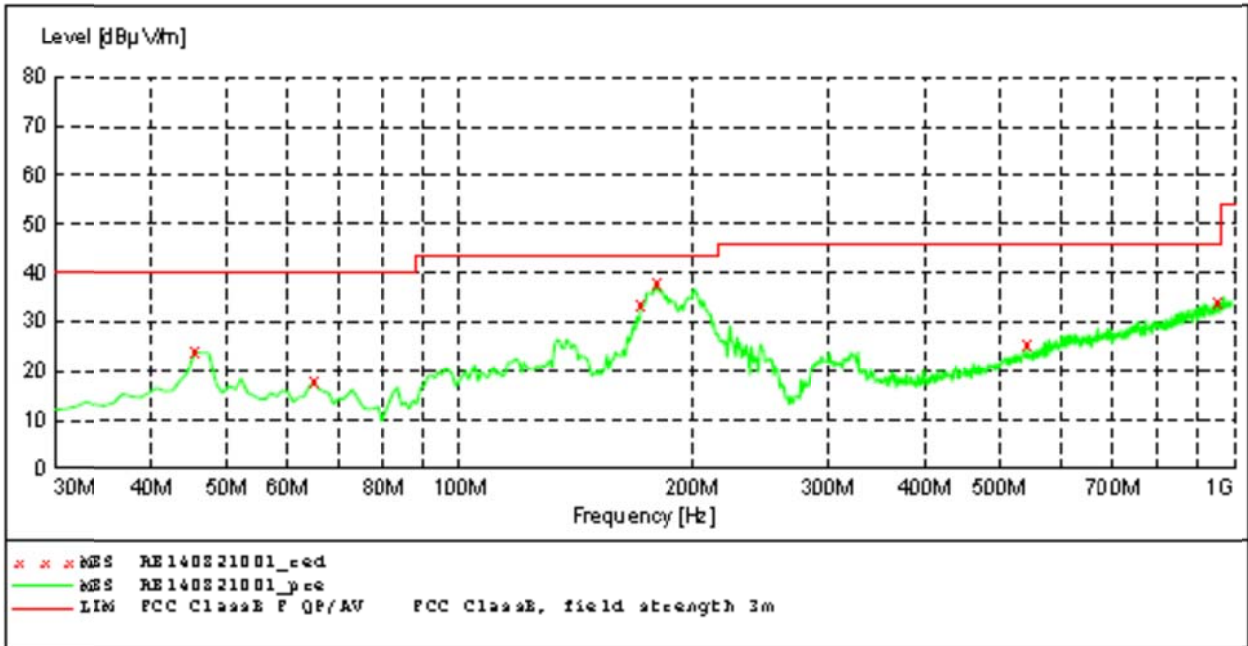

**MEASUREMENT RESULT: "RE140821001\_red"**

8/21/2014 11:28AM

Frequency MHz	Level dBµV/m	Transd dB	Limit dBµV/m	Margin dB	Det.	Height cm	Azimuth deg	Polarization
45.520000	23.80	-15.0	40.0	16.2	QP	300.0	283.00	HORIZONTAL
64.920000	17.60	-17.4	40.0	22.4	QP	300.0	141.00	HORIZONTAL
171.620000	33.70	-16.7	43.5	9.8	QP	100.0	88.00	HORIZONTAL
180.350000	37.80	-15.9	43.5	5.7	QP	300.0	79.00	HORIZONTAL
541.190000	25.50	-5.6	46.0	20.5	QP	300.0	360.00	HORIZONTAL
954.410000	33.90	3.5	46.0	12.1	QP	100.0	135.00	HORIZONTAL



**SWEEP TABLE: "test (30M-1G)"**

Short Description:		Field Strength			
Start	Stop	Detector	Meas.	IF	Transducer
Frequency	Frequency		Time	Bandw.	
30.0 MHz	1.1 GHz	MaxPeak	Coupled	100 kHz	VULB9163

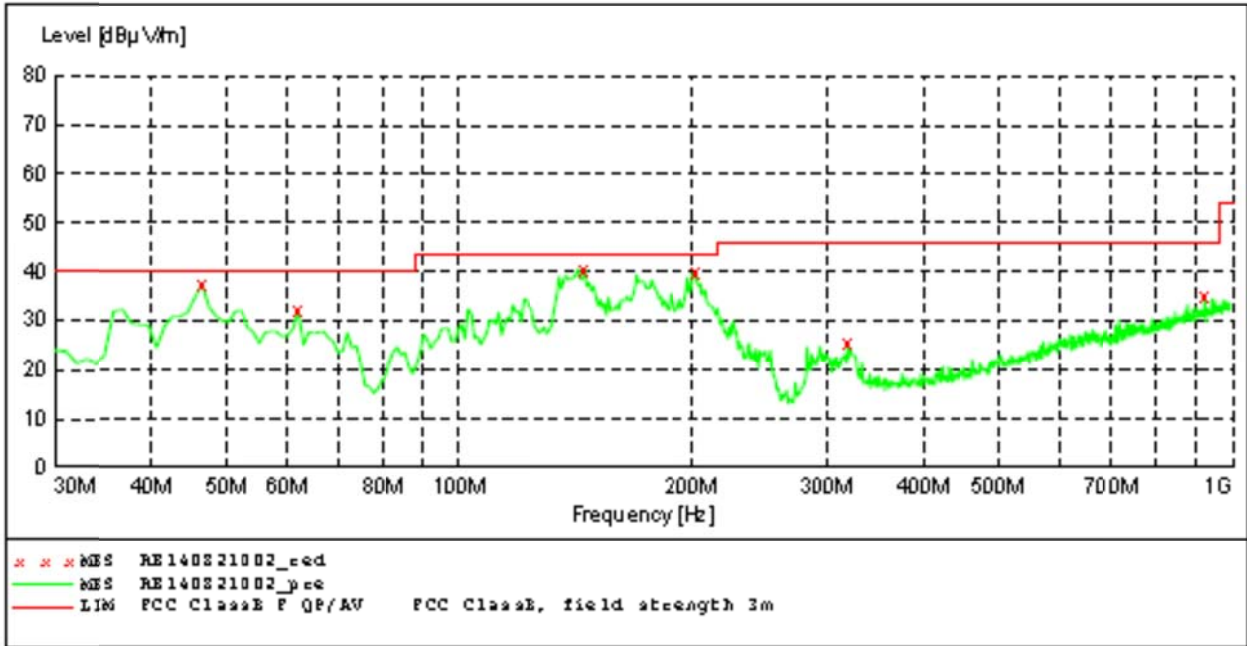

**MEASUREMENT RESULT: "RE140821002\_red"**

8/21/2014 11:32AM

Frequency MHz	Level dBµV/m	Transd dB	Limit dBµV/m	Margin dB	Det.	Height cm	Azimuth deg	Polarization
46.490000	37.50	-15.1	40.0	2.5	QP	100.0	5.00	VERTICAL
62.010000	32.00	-16.4	40.0	8.0	QP	100.0	5.00	VERTICAL
145.430000	40.50	-18.4	43.5	3.0	QP	100.0	114.00	VERTICAL
202.660000	39.60	-14.6	43.5	3.9	QP	100.0	164.00	VERTICAL
319.060000	25.30	-13.3	46.0	20.7	QP	100.0	360.00	VERTICAL
921.430000	35.10	3.0	46.0	10.9	QP	100.0	336.00	VERTICAL

**Above 1GHz**

Test channel:	01
---------------	----

**Peak value:**

Frequency (MHz)	Read Level (dBuV)	Antenna Factor (dB/m)	Cable Loss (dB)	Preamp Factor (dB)	Level (dBuV/m)	Limit Line (dBuV/m)	Margin Limit (dB)	Polarization
4824	37.89	31.44	5.87	35.46	39.74	74	-34.26	Vertical
7236	35.38	36.38	7.08	35.32	43.52	74	-30.48	Vertical
9648	37.37	38.01	9.01	35.72	48.67	74	-25.33	Vertical
12060	*					74		Vertical
14472	*					74		Vertical
4824	40.73	31.44	5.87	35.46	42.58	74	-31.42	Horizontal
7236	36.53	36.38	7.08	35.32	44.67	74	-29.33	Horizontal
9648	37.22	38.01	9.01	35.72	48.52	74	-25.48	Horizontal
12060	*					74		Horizontal
14472	*					74		Horizontal

**Average value:**

Frequency (MHz)	Read Level (dBuV)	Antenna Factor (dB/m)	Cable Loss (dB)	Preamp Factor (dB)	Level (dBuV/m)	Limit Line (dBuV/m)	Margin Limit (dB)	Polarization
4824	33.78	31.44	5.87	35.46	35.63	54	-18.37	Vertical
7236	28.24	36.38	7.08	35.32	36.38	54	-17.62	Vertical
9648	26.29	38.01	9.01	35.72	37.59	54	-16.41	Vertical
12060	*					54		Vertical
14472	*					54		Vertical
4824	34.04	31.44	5.87	35.46	35.89	54	-18.11	Horizontal
7236	28.6	36.38	7.08	35.32	36.74	54	-17.26	Horizontal
9648	26.26	38.01	9.01	35.72	37.56	54	-16.44	Horizontal
12060	*					54		Horizontal
14472	*					54		Horizontal

**Remark:**

1. Final Level = Receiver Read level + Antenna Factor + Cable Loss – Pre-amplifier Factor
2. “\*”, means this data is too weak instrument of signal is unable to test.
3. The emission levels of other frequencies are very lower than the limit and not show in test report.

Test channel:	06
---------------	----

**Peak value:**

Frequency (MHz)	Read Level (dBuV)	Antenna Factor (dB/m)	Cable Loss (dB)	Preamp Factor (dB)	Level (dBuV/m)	Limit Line (dBuV/m)	Over Limit (dB)	Polarization
4874	39.54	30.88	5.7	35.27	40.85	74	-33.15	Vertical
7311	36.09	35.82	6.91	35.13	43.69	74	-30.31	Vertical
9748	36.78	37.45	8.84	35.53	47.54	74	-26.46	Vertical
12185	*					74		Vertical
14622	*					74		Vertical
4874	41.53	30.88	5.7	35.27	42.84	74	-31.16	Horizontal
7311	37.18	35.82	6.91	35.13	44.78	74	-29.22	Horizontal
9748	37.83	37.45	8.84	35.53	48.59	74	-25.41	Horizontal
12185	*					74		Horizontal
14622	*					74		Horizontal

**Average value:**

Frequency (MHz)	Read Level (dBuV)	Antenna Factor (dB/m)	Cable Loss (dB)	Preamp Factor (dB)	Level (dBuV/m)	Limit Line (dBuV/m)	Over Limit (dB)	Polarization
4874	34.44	30.88	5.7	35.27	35.75	54	-18.25	Vertical
7311	29.04	35.82	6.91	35.13	36.64	54	-17.36	Vertical
9748	26.83	37.45	8.84	35.53	37.59	54	-16.41	Vertical
12185	*					54		Vertical
14622	*					54		Vertical
4874	34.12	30.88	5.7	35.27	35.43	54	-18.57	Horizontal
7311	28.98	35.82	6.91	35.13	36.58	54	-17.42	Horizontal
9748	27.09	37.45	8.84	35.53	37.85	54	-16.15	Horizontal
12185	*					54		Horizontal
14622	*					54		Horizontal

**Remark:**

1. Final Level = Receiver Read level + Antenna Factor + Cable Loss – Pre-amplifier Factor
2. “\*”, means this data is too weak instrument of signal is unable to test.
3. The emission levels of other frequencies are very lower than the limit and not show in test report.

Test channel:	11
---------------	----

**Peak value:**

Frequency (MHz)	Read Level (dBuV)	Antenna Factor (dB/m)	Cable Loss (dB)	Preamp Factor (dB)	Level (dBuV/m)	Limit Line (dBuV/m)	Over Limit (dB)	Polarization
4924	41.17	30.98	5.73	35.32	42.56	74	-31.44	Vertical
7386	37.16	35.92	6.94	35.18	44.84	74	-29.16	Vertical
9848	38.11	37.55	8.87	35.58	48.95	74	-25.05	Vertical
12310	*					74		Vertical
14772	*					74		Vertical
4924	40.29	30.98	5.73	35.32	41.68	74	-32.32	Horizontal
7386	38.06	35.92	6.94	35.18	45.74	74	-28.26	Horizontal
9848	36.54	37.55	8.87	35.58	47.38	74	-26.62	Horizontal
12310	*					74		Horizontal
14772	*					74		Horizontal

**Average value:**

Frequency (MHz)	Read Level (dBuV)	Antenna Factor (dB/m)	Cable Loss (dB)	Preamp Factor (dB)	Level (dBuV/m)	Limit Line (dBuV/m)	Over Limit (dB)	Polarization
4924	35.19	30.98	5.73	35.32	36.58	54	-17.42	Vertical
7386	28.79	35.92	6.94	35.18	36.47	54	-17.53	Vertical
9848	27.01	37.55	8.87	35.58	37.85	54	-16.15	Vertical
12310	*					54		Vertical
14772	*					54		Vertical
4924	34.24	30.98	5.73	35.32	35.63	54	-18.37	Horizontal
7386	28.8	35.92	6.94	35.18	36.48	54	-17.52	Horizontal
9848	26.75	37.55	8.87	35.58	37.59	54	-16.41	Horizontal
12310	*					54		Horizontal
14772	*					54		Horizontal

**Remark:**

1. Final Level = Receiver Read level + Antenna Factor + Cable Loss – Pre-amplifier Factor
2. “\*”, means this data is too weak instrument of signal is unable to test.
3. The emission levels of other frequencies are very lower than the limit and not show in test report.

## 5. Test Setup Photos of the EUT

Radiated Emission (30MHz-1GHz)



Radiated Emission (above 1GHz)



Conducted Emission (AC Mains)



## 6. External and Internal Photos of the EUT External photos of the EUT



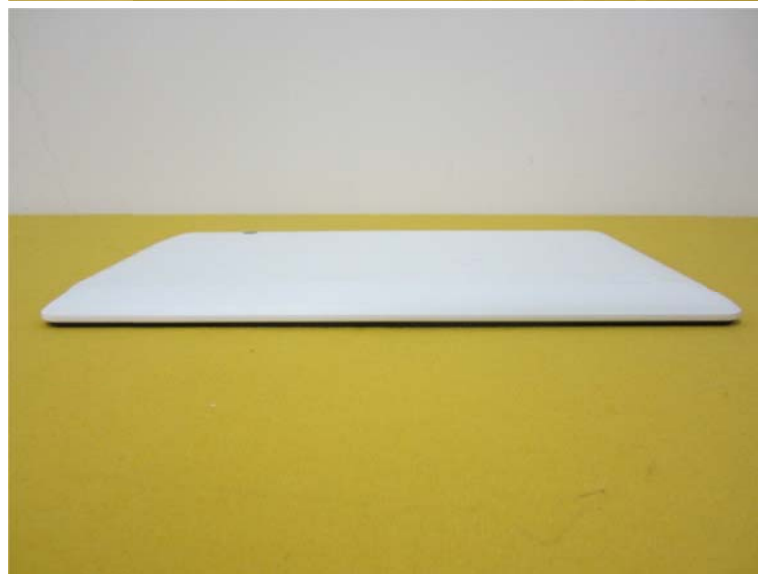





Internal photos of the EUT



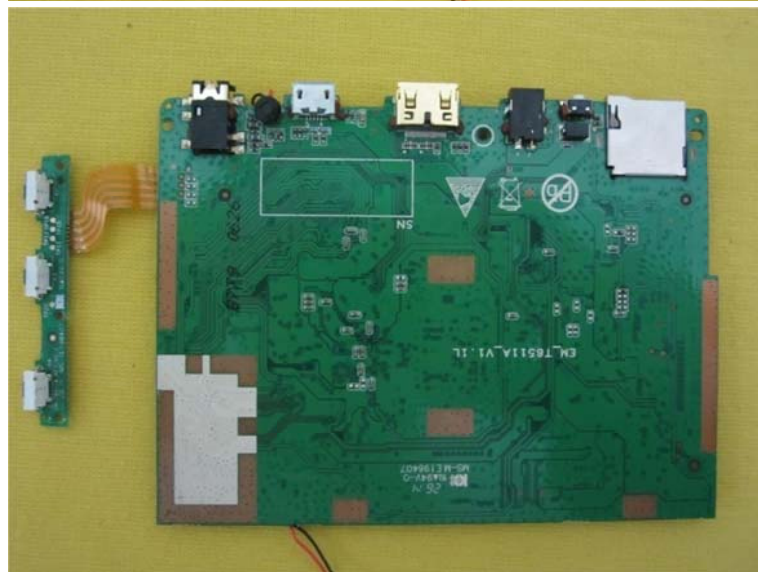

.....End of Report.....