



TEST REPORT

Report Reference No..... : **TRE1408006502** R/C.....: 92788

FCC ID..... : **2AAP6M1041**

Applicant's name..... : **SHENZHEN ZOWEE TECHNOLOGY CO.,LTD**

Address..... : Science &Technology Industrial Park of Privately Owned Enterprises, Pingshan, Xili, Nanshan District, Shenzhen, PR CHINA

Manufacturer..... : SHENZHEN ZOWEE TECHNOLOGY CO.,LTD

Address..... : Science &Technology Industrial Park of Privately Owned Enterprises, Pingshan, Xili, Nanshan District, Shenzhen, PR CHINA

Test item description : **Internet Tablet**

Trade Mark : NOBIS,DOPO,TMAX,APEX,D.AGE,NUVISION

Model/Type reference..... : M1041

Listed Model(s)..... : NB1022, NB1022S, DPM1081, DPM1081K, D1081, M1081, M1080, D1022, M1022, DM1022, DM1020, DPM1020, NB1020, NB1020S, NB1081, NB1080

Standard : **FCC CFR Title 47 Part 15 Subpart C Section 15.247**

Date of receipt of test sample..... : Aug 19, 2014

Date of testing : Aug 19 ~ Sept 01, 2014

Date of issue..... : Sept 01, 2014

Result..... : **PASS**

Compiled by
(position+printed name+signature)..: File administrators Any Yang

Supervised by
(position+printed name+signature)..: Project Engineer Lion Cai

Approved by
(position+printed name+signature)..: RF Manager Hans Hu

Testing Laboratory Name : **Shenzhen Huatongwei International Inspection Co., Ltd**

Address..... : Keji Nan No.12 Road, Hi-tech Park, Shenzhen, China

Shenzhen Huatongwei International Inspection Co., Ltd. All rights reserved.

This publication may be reproduced in whole or in part for non-commercial purposes as long as the Shenzhen Huatongwei International Inspection Co., Ltd is acknowledged as copyright owner and source of the material. Shenzhen Huatongwei International Inspection Co., Ltd takes no responsibility for and will not assume liability for damages resulting from the reader's interpretation of the reproduced material due to its placement and context.

Contents

1.	<u>TEST STANDARDS AND TEST DESCRIPTION</u>	3
1.1.	Test Standards	3
1.2.	Test Description	3
2.	<u>SUMMARY</u>	4
2.1.	Client Information	4
2.2.	Product Description	4
2.3.	EUT operation mode	5
2.4.	EUT configuration	5
2.5.	Modifications	5
3.	<u>TEST ENVIRONMENT</u>	6
3.1.	Address of the test laboratory	6
3.2.	Test Facility	6
3.3.	Environmental conditions	7
3.4.	Statement of the measurement uncertainty	7
3.5.	Equipments Used during the Test	8
4.	<u>TEST CONDITIONS AND RESULTS</u>	9
4.1.	Antenna requirement	9
4.2.	Conducted Emission (AC Main)	10
4.3.	Conducted Peak Output Power	13
4.4.	20dB Emission Bandwidth	17
4.5.	Carrier Frequencies Separation	21
4.6.	Hopping Channel Number	23
4.7.	Dwell Time	25
4.8.	Pseudorandom Frequency Hopping Sequence	29
4.9.	Band Edge	30
4.10.	Spurious Emission (conducted)	37
4.11.	Spurious Emission (radiated)	39
5.	<u>TEST SETUP PHOTOS OF THE EUT</u>	48
6.	<u>EXTERNAL AND INTERNAL PHOTOS OF THE EUT</u>	49

1. TEST STANDARDS AND TEST DESCRIPTION

1.1. Test Standards

The tests were performed according to following standards:

[FCC Rules Part 15.247](#): Frequency Hopping, Direct Spread Spectrum and Hybrid Systems that are in operation within the bands of 902-928 MHz, 2400-2483.5 MHz, and 5725-5850 MHz.

[ANSI C63.10-2009](#): American National Standard for Testing Unlicensed Wireless Devices

1.2. Test Description

Test Item	Section in CFR 47	Result
Antenna Requirement	15.203/15.247 (c)	Pass
AC Power Line Conducted Emission	15.207	Pass
Conducted Peak Output Power	15.247 (b)(1)	Pass
20dB Occupied Bandwidth	15.247 (a)(1)	Pass
Carrier Frequencies Separation	15.247 (a)(1)	Pass
Hopping Channel Number	15.247 (a)(1)	Pass
Dwell Time	15.247 (a)(1)	Pass
Pseudorandom Frequency Hopping Sequence	15.247(b)(4)&TCB Exclusion List (7 July 2002)	Pass
Band Edge	15.247(d)	Pass
Radiated Emission	15.205/15.209	Pass

Remark: The measurement uncertainty is not included in the test result.

2. SUMMARY

2.1. Client Information

Applicant:	SHENZHEN ZOWEE TECHNOLOGY CO.,LTD
Address:	Science &Technology Industrial Park of Privately Owned Enterprises, Pingshan, Xili, Nanshan District, Shenzhen, PR CHINA
Manufacturer:	SHENZHEN ZOWEE TECHNOLOGY CO.,LTD
Address:	Science &Technology Industrial Park of Privately Owned Enterprises, Pingshan, Xili, Nanshan District, Shenzhen, PR CHINA

2.2. Product Description

Name of EUT	Internet Tablet
Trade Mark:	NOBIS,DOPO,TMAX,APEX,D.AGE,NUVISION
Model No.:	M1041
Listed Model(s):	NB1022, NB1022S, DPM1081, DPM1081K, D1081, M1081, M1080, D1022, M1022, DM1022, DM1020, DPM1020, NB1020, NB1020S, NB1081, NB1080
Power supply:	DC 3.7V From Internal Battery
Adapter information:	Model No.:JK050200-S04USA Input: AC 100~240V, 50/60Hz, 0.5A Output: DC 5.0V 2A
Bluetooth	
Version:	Supported BT2.1+EDR
Modulation:	GFSK, $\pi/4$ DQPSK, 8DPSK
Operation frequency:	2402MHz~2480MHz
Channel number:	79
Channel separation:	1MHz
Antenna type:	Internal Antenna
Antenna gain:	2.0dBi

Operation Frequency List:

Channel	Frequency (MHz)
1	2402
2	2403
⋮	⋮
39	2440
40	2441
41	2442
⋮	⋮
78	2479
79	2480

Note:

In section 15.31(m), regards to the operating frequency range over 10 MHz, the Lowest frequency, the middle frequency, and the highest frequency of channel were selected to perform the test, please see the above gray bottom.

2.3. EUT operation mode

The EUT has been tested under typical operating condition. The Applicant provides software to control the EUT for staying in continuous transmitting and receiving mode for testing.

2.4. EUT configuration

The following peripheral devices and interface cables were connected during the measurement:

● - supplied by the manufacturer

○ - supplied by the lab

<input type="radio"/>	Power Cable	Length (m) :	/
		Shield :	/
		Detachable :	/
<input type="radio"/>	Multimeter	Manufacturer :	/
		Model No. :	/

2.5. Modifications

No modifications were implemented to meet testing criteria.

3. TEST ENVIRONMENT

3.1. Address of the test laboratory

Shenzhen Huatongwei International Inspection Co., Ltd.
Keji Nan No.12 Road, Hi-tech Park, Shenzhen, China
Phone: 86-755-26748019 Fax: 86-755-26748089

3.2. Test Facility

The test facility is recognized, certified, or accredited by the following organizations:

CNAS-Lab Code: L1225

Shenzhen Huatongwei International Inspection Co., Ltd. has been assessed and proved to be in compliance with CNAS-CL01 Accreditation Criteria for Testing and Calibration Laboratories (identical to ISO/IEC 17025: 2005 General Requirements) for the Competence of Testing and Calibration Laboratories, Date of Registration: Mar. 01, 2012. Valid time is until February 28, 2015.

A2LA-Lab Cert. No. 2243.01

Shenzhen Huatongwei International Inspection Co., Ltd. EMC Laboratory has been accredited by A2LA for technical competence in the field of electrical testing, and proved to be in compliance with ISO/IEC 17025: 2005 General Requirements for the Competence of Testing and Calibration Laboratories and any additional program requirements in the identified field of testing. Valid time is until Sept 30, 2015.

FCC-Registration No.: 662850

Shenzhen Huatongwei International Inspection Co., Ltd. EMC Laboratory has been registered and fully described in a report filed with the FCC (Federal Communications Commission). The acceptance letter from the FCC is maintained in our files. Registration 662850, Renewal date Jul. 01, 2012, valid time is until Jun. 01, 2015.

IC-Registration No.: 5377A

The 3m Alternate Test Site of Shenzhen Huatongwei International Inspection Co., Ltd. has been registered by Certification and Engineering Bureau of Industry Canada for the performance of radiated measurements with Registration No. 5377A on Dec. 31, 2013, valid time is until Dec. 31, 2016.

ACA

Shenzhen Huatongwei International Inspection Co., Ltd. EMC Laboratory can also perform testing for the Australian C-Tick mark as a result of our A2LA accreditation.

VCCI

The 3m Semi-anechoic chamber (12.2m×7.95m×6.7m) of Shenzhen Huatongwei International Inspection Co., Ltd. has been registered in accordance with the Regulations for Voluntary Control Measures with Registration No.:R-2484. Date of Registration: Dec. 20, 2012. Valid time is until Dec. 29, 2015.

Radiated disturbance above 1GHz measurement of Shenzhen Huatongwei International Inspection Co., Ltd. has been registered in accordance with the Regulations for Voluntary Control Measures with Registration No.: G-292. Date of Registration: Dec. 24, 2013. Valid time is until Dec. 23, 2016.

Main Ports Conducted Interference Measurement of Shenzhen Huatongwei International Inspection Co., Ltd. has been registered in accordance with the Regulations for Voluntary Control Measures with Registration No.: C-2726. Date of Registration: Dec. 20, 2012. Valid time is until Dec. 19, 2015.

Telecommunication Ports Conducted Interference Measurement of Shenzhen Huatongwei International Inspection Co., Ltd. has been registered in accordance with the Regulations for Voluntary Control Measures with Registration No.: T-1837. Date of Registration: May 07, 2013. Valid time is until May 06, 2016.

DNV

Shenzhen Huatongwei International Inspection Co., Ltd. has been found to comply with the requirements of DNV towards subcontractor of EMC and safety testing services in conjunction with the EMC and Low voltage Directives and in the voluntary field. The acceptance is based on a formal quality Audit and follow-ups according to relevant parts of ISO/IEC Guide 17025 (2005), in accordance with the requirements of the DNV Laboratory Quality Manual towards subcontractors. Valid time is until Aug. 24, 2016.

3.3. Environmental conditions

During the measurement the environmental conditions were within the listed ranges:

Temperature:	15~35°C
Relative Humidity:	30~60 %
Air Pressure:	950~1050mba

3.4. Statement of the measurement uncertainty

The data and results referenced in this document are true and accurate. The reader is cautioned that there may be errors within the calibration limits of the equipment and facilities. The measurement uncertainty was calculated for all measurements listed in this test report according to TR-100028-01 "Electromagnetic compatibility and Radio spectrum Matters (ERM); Uncertainties in the measurement of mobile radio equipment characteristics; Part 1" and TR-100028-02 "Electromagnetic compatibility and Radio spectrum Matters (ERM); Uncertainties in the measurement of mobile radio equipment characteristics; Part 2" and is documented in the Shenzhen Huatongwei International Inspection Co., Ltd quality system according to DIN EN ISO/IEC 17025. Furthermore, component and process variability of devices similar to that tested may result in additional deviation. The manufacturer has the sole responsibility of continued compliance of the device.

Hereafter the best measurement capability for Shenzhen Huatongwei laboratory is reported:

Test Items	Measurement Uncertainty	Notes
Transmitter power conducted	0.57 dB	(1)
Transmitter power Radiated	2.20 dB	(1)
Conducted spurious emission 9KHz-40 GHz	1.60 dB	(1)
Radiated spurious emission 9KHz-40 GHz	2.20 dB	(1)
Conducted Emission 9KHz-30MHz	3.39 dB	(1)
Radiated Emission 30~1000MHz	4.24 dB	(1)
Radiated Emission 1~18GHz	5.16 dB	(1)
Radiated Emission 18-40GHz	5.54 dB	(1)
Occupied Bandwidth	-----	(1)

(1) This uncertainty represents an expanded uncertainty expressed at approximately the 95% confidence level using a coverage factor of $k=1.96$.

3.5. Equipments Used during the Test

AC Power Conducted Emission					
Item	Test Equipment	Manufacturer	Model No.	Serial No.	Cal Due
1	Artificial Mains	Rohde&Schwarz	ESH2-Z5	100028	2014/10/25
2	EMI Test Receiver	Rohde&Schwarz	ESCI3	100038	2014/10/25
3	Pulse Limiter	Rohde&Schwarz	ESHSZ2	100044	2014/10/25
4	EMI Test Software	Rohde&Schwarz	ES-K1 V1.71	N/A	N/A

Radiated Emission					
Item	Test Equipment	Manufacturer	Model No.	Serial No.	Cal Due
1	Ultra-Broadband Antenna	ShwarzBeck	VULB9163	538	2014/10/25
2	EMI TEST RECEIVER	Rohde&Schwarz	ESI 26	100009	2014/10/25
3	EMI TEST Software	Audix	E3	N/A	N/A
4	TURNTABLE	ETS	2088	2149	N/A
5	ANTENNA MAST	ETS	2075	2346	N/A
6	EMI TEST Software	Rohde&Schwarz	ESK1	N/A	N/A
7	HORN ANTENNA	ShwarzBeck	9120D	1011	2014/10/25
8	Amplifer	Sonoma	310N	E009-13	2014/10/25
9	JS amplifer	Rohde&Schwarz	JS4-00101800-28-5A	F201504	2014/10/25
10	High pass filter	Compliance Direction systems	BSU-6	34202	2014/10/25
11	HORN ANTENNA	ShwarzBeck	9120D	1012	2014/10/25
12	Amplifer	Compliance Direction systems	PAP1-4060	120	2014/10/25
13	Loop Antenna	Rohde&Schwarz	HFH2-Z2	100020	2014/10/25
14	TURNTABLE	MATURO	TT2.0	----	N/A
15	ANTENNA MAST	MATURO	TAM-4.0-P	----	N/A
16	Horn Antenna	SCHWARZBECK	BBHA9170	25841	2014/10/25
17	ULTRA-BROADBAND ANTENNA	Rohde&Schwarz	HL562	100015	2014/10/25

Maximum Peak Output Power / Power Spectral Density / 6dB Bandwidth / Band Edge Compliance of RF Emission / Spurious RF Conducted Emission					
Item	Test Equipment	Manufacturer	Model No.	Serial No.	Cal Due
1	Spectrum Analyzer	Rohde&Schwarz	FSP	1164.4391.40	2014/10/25

The Cal.Interval was one year

4. TEST CONDITIONS AND RESULTS

4.1. Antenna requirement

Requirement

FCC CFR Title 47 Part 15 Subpart C Section 15.203:

An intentional radiator shall be designed to ensure that no antenna other than that furnished by the responsible party shall be used with the device. The use of a permanently attached antenna or of an antenna that uses a unique coupling to the intentional radiator, the manufacturer may design the unit so that a broken antenna can be replaced by the user, but the use of a standard antenna jack or electrical connector is prohibited.

FCC CFR Title 47 Part 15 Subpart C Section 15.247(c) (1)(i):

(i) Systems operating in the 2400-2483.5 MHz band that is used exclusively for fixed. Point-to-point operations may employ transmitting antennas with directional gain greater than 6dBi provided the maximum conducted output power of the intentional radiator is reduced by 1 dB for every 3 dB that the directional gain of the antenna exceeds 6dBi.

Test Result:

The antenna is integral antenna, the best case gain of the antenna is 2.0dBi

WIFI&BT Antenna Location

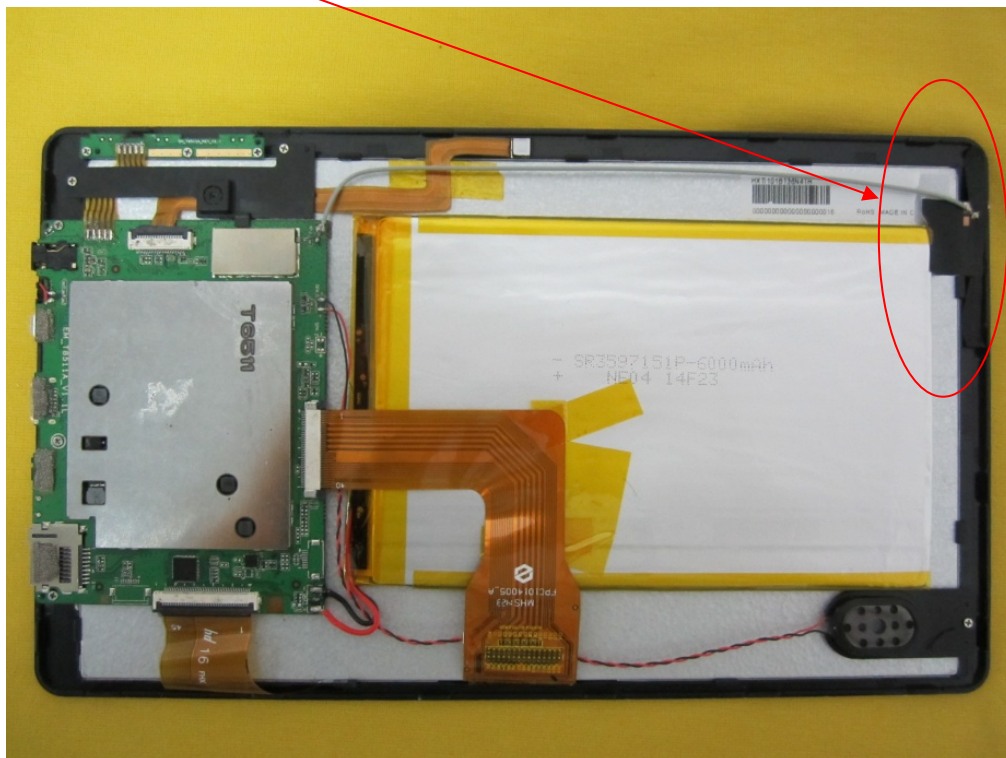

4.2. Conducted Emission (AC Main)

LIMIT

FCC CFR Title 47 Part 15 Subpart C Section 15.207

Frequency range (MHz)	Limit (dBuV)	
	Quasi-peak	Average
0.15-0.5	66 to 56*	56 to 46*
0.5-5	56	46
5-30	60	50

* Decreases with the logarithm of the frequency.

TEST CONFIGURATION

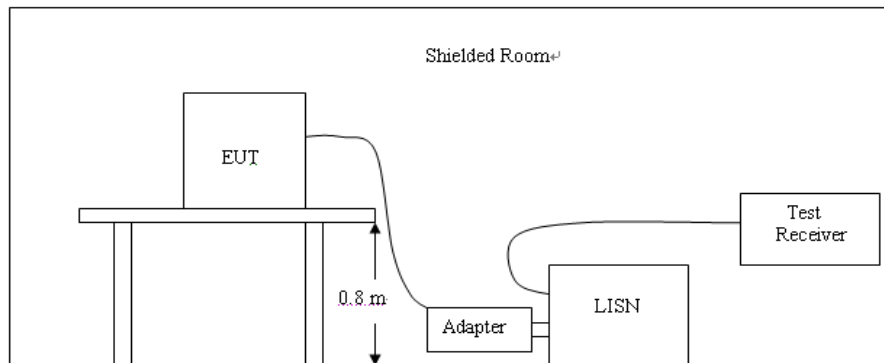

TEST PROCEDURE

1. The equipment was set up as per the test configuration to simulate typical actual usage per the user's manual. The EUT is a tabletop system, a wooden table with a height of 0.8 meters is used and is placed on the ground plane as per ANSI C63.10-2009.
2. Support equipment, if needed, was placed as per ANSI C63.10-2009
3. All I/O cables were positioned to simulate typical actual usage as per ANSI C63.10-2009
4. The EUT received DC5V power from the adapter, the adapter received AC120V/60Hz power through a Line Impedance Stabilization Network (LISN) which supplied power source and was grounded to the ground plane.
5. All support equipments received AC power from a second LISN, if any.
6. The EUT test program was started. Emissions were measured on each current carrying line of the EUT using a spectrum Analyzer / Receiver connected to the LISN powering the EUT. The LISN has two monitoring points: Line 1 (Hot Side) and Line 2 (Neutral Side). Two scans were taken: one with Line 1 connected to Analyzer / Receiver and Line 2 connected to a 50 ohm load; the second scan had Line 1 connected to a 50 ohm load and Line 2 connected to the Analyzer / Receiver.
7. Analyzer / Receiver scanned from 150 KHz to 30MHz for emissions in each of the test modes.
8. During the above scans, the emissions were maximized by cable manipulation.

TEST RESULTS

Test mode:	Bluetooth mode	Polarization	N
------------	----------------	--------------	---

SCAN TABLE: "Voltage (9K-30M)FIN"
 Short Description: 150K-30M Voltage

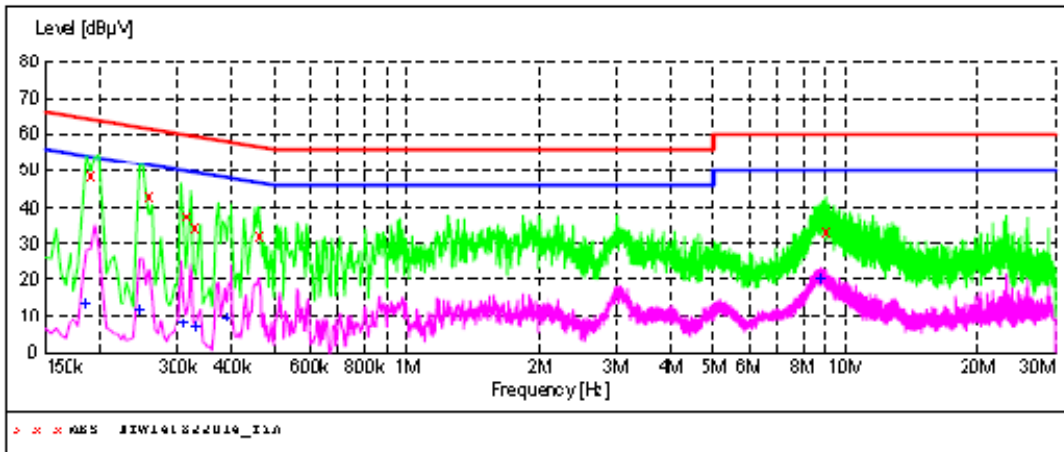

MEASUREMENT RESULT: "HPW140822014_fin"

8/22/2014 2:54PM

Frequency MHz	Level dBµV	Transc dE	Limit dBµV	Margin dB	Detector	Line	PE
0.190000	48.70	12.1	64	15.3	QP	K	GND
0.250000	42.90	11.8	62	18.6	QP	K	GND
0.314000	37.70	11.4	60	22.2	QP	K	GND
0.330000	34.50	11.2	60	25.0	QP	K	GND
0.450000	32.10	10.1	57	24.6	QP	K	GND
9.014000	33.30	10.3	60	26.7	QP	A	GND

MEASUREMENT RESULT: "HPW140822014_fin2"

8/22/2014 2:54PM

Frequency MHz	Level dBµV	Transc dE	Limit dBµV	Margin dB	Detector	Line	PE
0.180000	13.60	12.1	54	40.6	AV	K	GND
0.240000	12.00	11.8	52	39.9	AV	A	GND
0.310000	8.40	11.5	50	41.6	AV	K	GND
0.330000	7.40	11.2	50	42.1	AV	K	GND
0.380000	9.70	10.6	48	38.4	AV	K	GND
9.770000	20.60	10.3	50	39.4	AV	K	GND

4.3. Conducted Peak Output Power

LIMIT

FCC CFR Title 47 Part 15 Subpart C Section 15.247 (b)(3): **30dBm**

TEST CONFIGURATION



TEST PROCEDURE

Remove the antenna from the EUT and then connect a low loss RF cable from the antenna port to the spectrum.

TEST RESULTS

Modulation type	Channel	Output power (dBm)	Limit (dBm)	Result
GFSK	01	7.164	30	Pass
	40	7.593		
	79	7.511		
π/4DQPSK	01	6.455	21	Pass
	40	6.911		
	79	6.876		
8DPSK	01	6.45	21	Pass
	40	6.925		
	79	6.892		

Test plot as follows:

GFSK Modulation

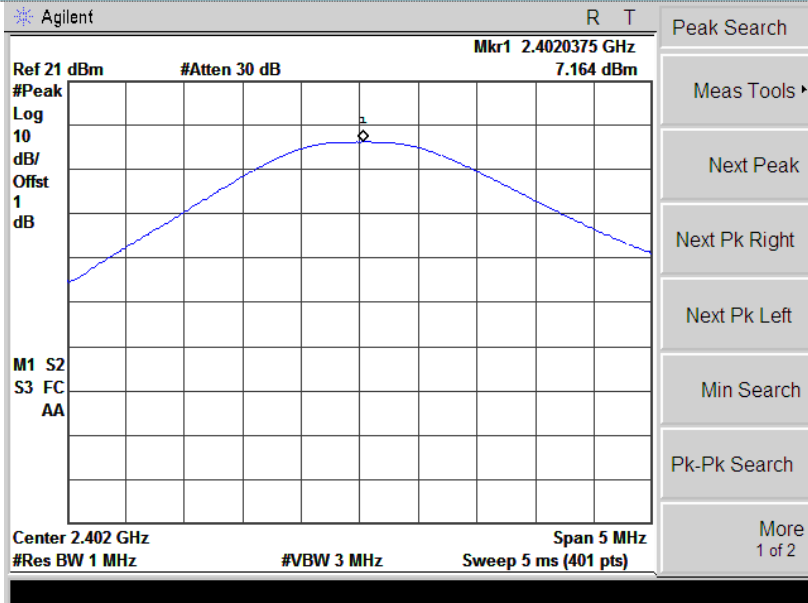

CH01

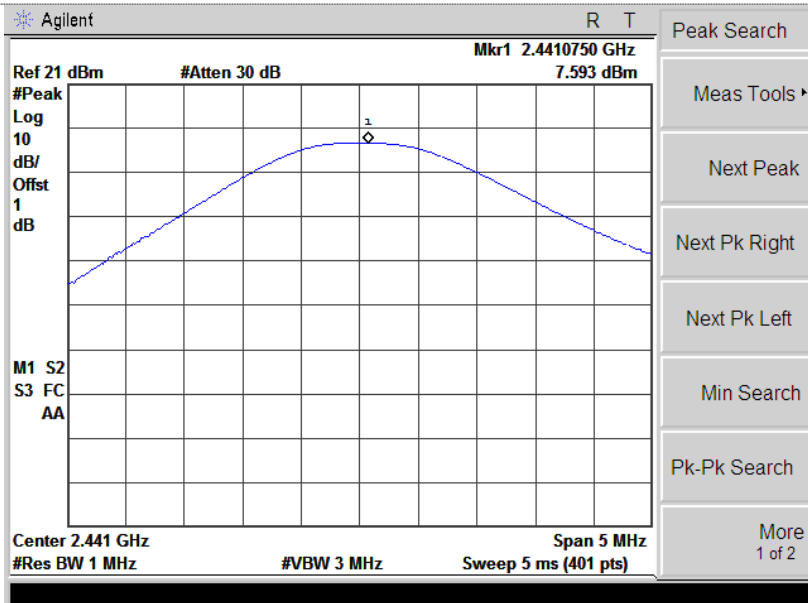

CH40

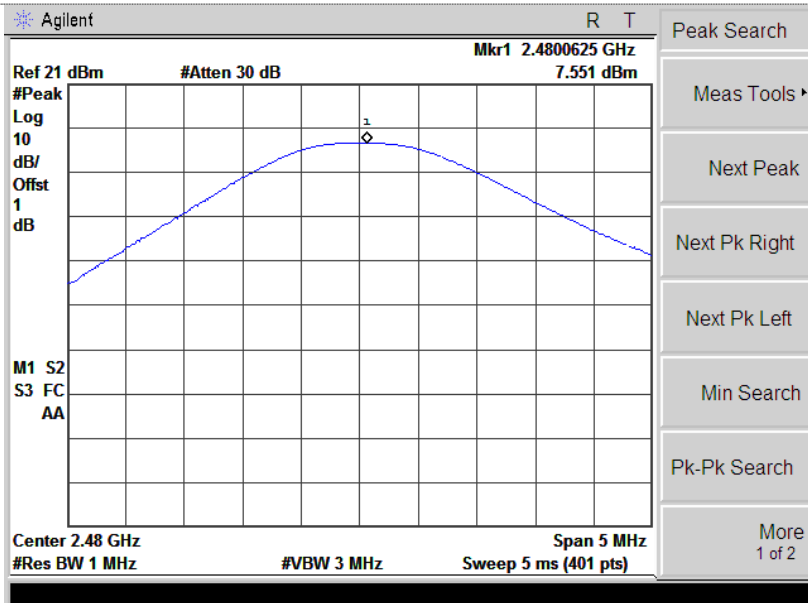

CH79

$\pi/4$ DQPSK Modulation

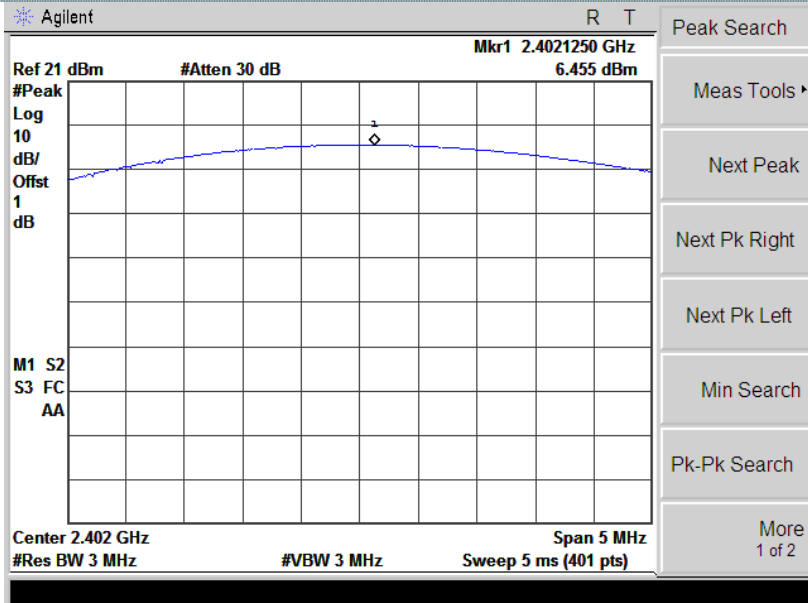

CH01

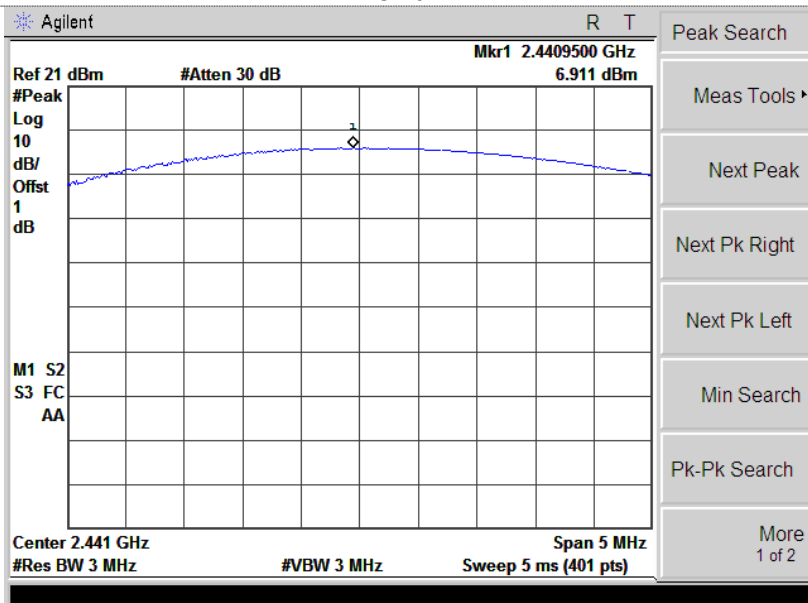

CH40

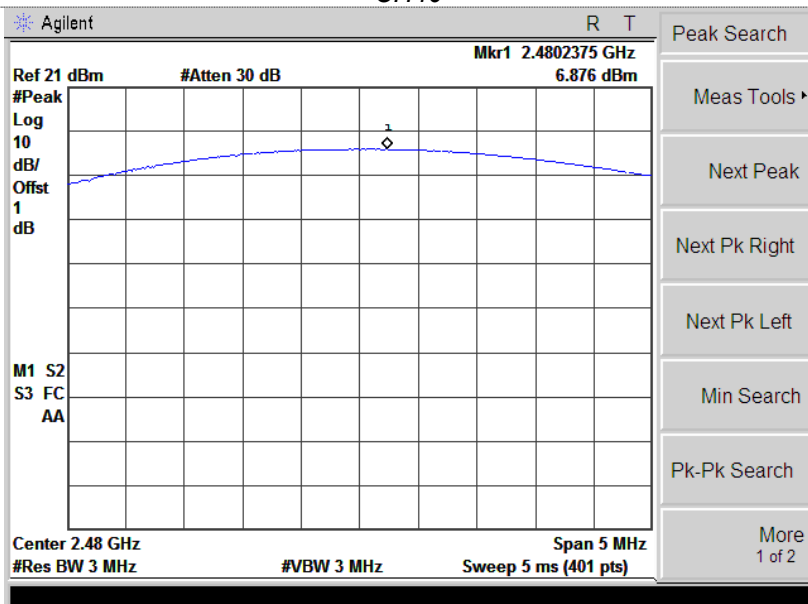

CH79

8DPSK Modulation

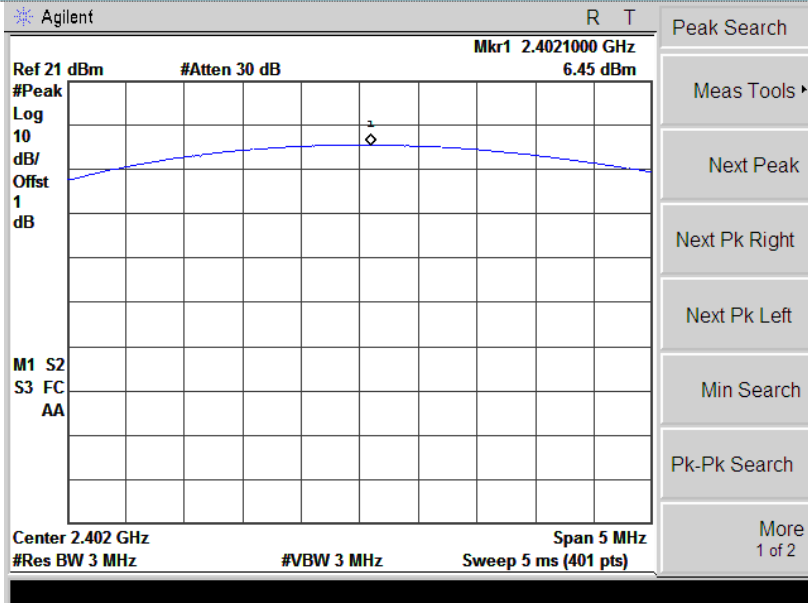

CH01

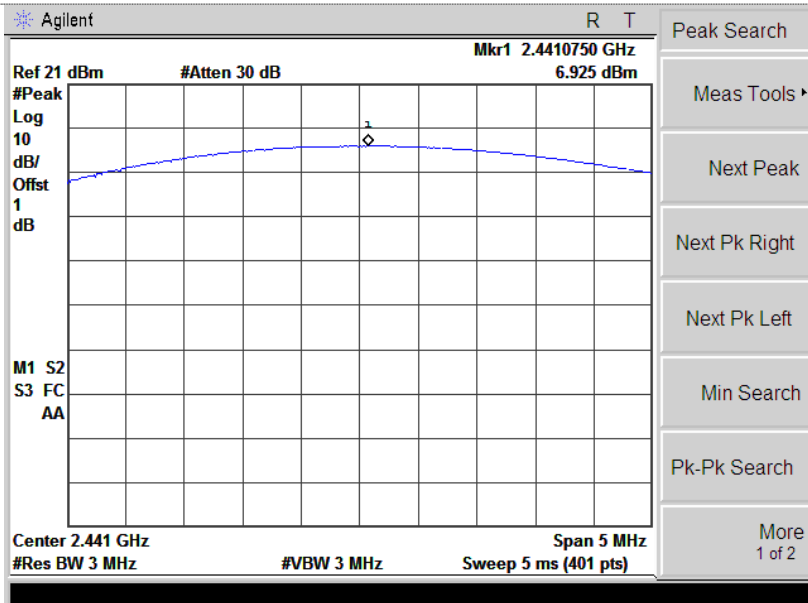

CH40

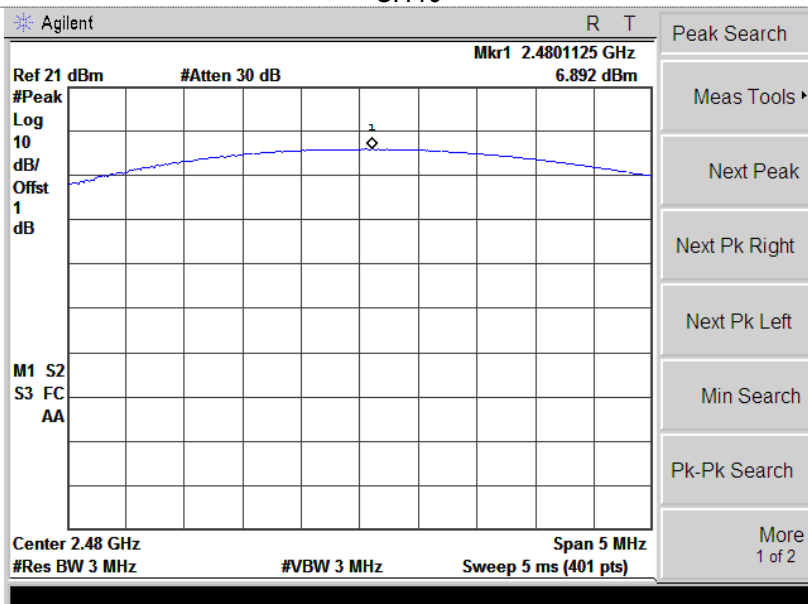

CH79

4.4. 20dB Emission Bandwidth

LIMIT

N/A

TEST CONFIGURATION



TEST PROCEDURE

1. The transmitter output was connected to the spectrum analyzer through an attenuator.
2. The bandwidth of the fundamental frequency was measured by spectrum analyzer with RBW=30 KHz and VBW=100KHz.
3. The 20dB bandwidth is defined as the total spectrum the power of which is higher than peak power minus 20dB.

TEST RESULTS

Modulation type	Channel	20dB Bandwidth (MHz)	Limit (MHz)	Result
GFSK	01	0.808	/	Pass
	40	0.805		
	79	0.706		
π/4DQPSK	01	1.144	/	Pass
	40	1.141		
	79	1.144		
8DPSK	01	1.165	/	Pass
	40	1.166		
	79	1.163		

Test plot as follows:

GFSK Modulation

Agilent R T

Ch Freq 2.402 GHz Trig Free

Occupied Bandwidth

Center 2.40200000 GHz

Ref 21 dBm #Atten 30 dB

Center 2.402 GHz Span 3 MHz
#Res BW 10 kHz #VBW 30 kHz Sweep 31.08 ms (401 pts)

Occupied Bandwidth 837.4759 kHz Occ BW % Pwr 99.00 %
x dB -20.00 dB

Transmit Freq Error -7.463 kHz
x dB Bandwidth 808.094 kHz

Freq/Channel
Center Freq 2.40200000 GHz
Start Freq 2.40050000 GHz
Stop Freq 2.40350000 GHz
CF Step 300.000000 kHz
Auto Man
Freq Offset 0.00000000 Hz
Signal Track On Off
Scale Type Log Lin

CH01

Agilent R T

Ch Freq 2.441 GHz Trig Free

Occupied Bandwidth

Center 2.44100000 GHz

Ref 21 dBm #Atten 30 dB

Center 2.441 GHz Span 3 MHz
#Res BW 10 kHz #VBW 30 kHz Sweep 31.08 ms (401 pts)

Occupied Bandwidth 829.3486 kHz Occ BW % Pwr 99.00 %
x dB -20.00 dB

Transmit Freq Error -9.319 kHz
x dB Bandwidth 805.681 kHz

Trace/View
Trace 1 2 3
Clear Write
Max Hold
Min Hold
View
Blank
More 1 of 2

CH40

Agilent R T

Ch Freq 2.48 GHz Trig Free

Occupied Bandwidth

Center 2.48 GHz

Ref 21 dBm #Atten 30 dB

Center 2.48 GHz Span 3 MHz
#Res BW 10 kHz #VBW 30 kHz Sweep 31.08 ms (401 pts)

Occupied Bandwidth 824.7513 kHz Occ BW % Pwr 99.00 %
x dB -20.00 dB

Transmit Freq Error -10.527 kHz
x dB Bandwidth 706.744 kHz

Trace/View
Trace 1 2 3
Clear Write
Max Hold
Min Hold
View
Blank
More 1 of 2

CH79

π/4DQPSK Modulation

Agilent R T

Ch Freq 2.402 GHz Trig Free

Occupied Bandwidth [] []

Center 2.402000000 GHz

Ref 21 dBm #Atten 30 dB

#Peak Log 10 dB/Offst 1 dB

Center 2.402 GHz Span 3 MHz

#Res BW 30 kHz #VBW 100 kHz Sweep 5 ms (401 pts)

Occupied Bandwidth	Occ BW % Pwr	99.00 %
1.0750 MHz	x dB	-20.00 dB
Transmit Freq Error	-10.696 kHz	
x dB Bandwidth	1.144 MHz	

Freq/Channel

Center Freq 2.40200000 GHz

Start Freq 2.40050000 GHz

Stop Freq 2.40350000 GHz

CF Step 300.000000 kHz
Auto Man

Freq Offset 0.00000000 Hz

Signal Track On Off

Scale Type Log Lin

CH01

Agilent R T

Ch Freq 2.441 GHz Trig Free

Occupied Bandwidth [] []

Center 2.441000000 GHz

Ref 21 dBm #Atten 30 dB

#Peak Log 10 dB/Offst 1 dB

Center 2.441 GHz Span 3 MHz

#Res BW 30 kHz #VBW 100 kHz Sweep 5 ms (401 pts)

Occupied Bandwidth	Occ BW % Pwr	99.00 %
1.0764 MHz	x dB	-20.00 dB
Transmit Freq Error	-10.382 kHz	
x dB Bandwidth	1.141 MHz	

Freq/Channel

Center Freq 2.44100000 GHz

Start Freq 2.43950000 GHz

Stop Freq 2.44250000 GHz

CF Step 300.000000 kHz
Auto Man

Freq Offset 0.00000000 Hz

Signal Track On Off

Scale Type Log Lin

CH40

Agilent R T

Ch Freq 2.48 GHz Trig Free

Occupied Bandwidth [] []

Center 2.48 GHz

Ref 21 dBm #Atten 30 dB

#Peak Log 10 dB/Offst 1 dB

Center 2.48 GHz Span 3 MHz

#Res BW 30 kHz #VBW 100 kHz Sweep 5 ms (401 pts)

Occupied Bandwidth	Occ BW % Pwr	99.00 %
1.0751 MHz	x dB	-20.00 dB
Transmit Freq Error	-11.353 kHz	
x dB Bandwidth	1.144 MHz	

Trace/View

Trace 1 2 3

Clear Write

Max Hold

Min Hold

View

Blank

More 1 of 2

CH79

8DPSK Modulation

Agilent R T Trace/View

Ch Freq 2.402 GHz Trig Free

Occupied Bandwidth

Ref 21 dBm #Atten 30 dB

#Peak Log 10 dB/ Offst 1 dB

Center 2.402 GHz Span 3 MHz
#Res BW 30 kHz #VBW 100 kHz Sweep 5 ms (401 pts)

Occupied Bandwidth Occ BW % Pwr 99.00 %
1.0828 MHz x dB -20.00 dB

Transmit Freq Error -6.174 kHz
x dB Bandwidth 1.165 MHz

Trace 1 2 3

Clear Write

Max Hold

Min Hold

View

Blank

More 1 of 2

CH01

Agilent R T Trace/View

Ch Freq 2.441 GHz Trig Free

Occupied Bandwidth

Ref 21 dBm #Atten 30 dB

#Peak Log 10 dB/ Offst 1 dB

Center 2.441 GHz Span 3 MHz
#Res BW 30 kHz #VBW 100 kHz Sweep 5 ms (401 pts)

Occupied Bandwidth Occ BW % Pwr 99.00 %
1.0826 MHz x dB -20.00 dB

Transmit Freq Error -5.272 kHz
x dB Bandwidth 1.166 MHz

Trace 1 2 3

Clear Write

Max Hold

Min Hold

View

Blank

More 1 of 2

CH40

Agilent R T Freq/Channel

Ch Freq 2.48 GHz Trig Free

Occupied Bandwidth

Ref 21 dBm #Atten 30 dB

#Peak Log 10 dB/ Offst 1 dB

Center 2.48 GHz Span 3 MHz
#Res BW 30 kHz #VBW 100 kHz Sweep 5 ms (401 pts)

Occupied Bandwidth Occ BW % Pwr 99.00 %
1.0773 MHz x dB -20.00 dB

Transmit Freq Error -8.072 kHz
x dB Bandwidth 1.163 MHz

Center Freq 2.48000000 GHz

Start Freq 2.47850000 GHz

Stop Freq 2.48150000 GHz

CF Step 300.000000 kHz Auto Man

Freq Offset 0.00000000 Hz

Signal Track On Off

Scale Type Log Lin

CH79

4.5. Carrier Frequencies Separation

LIMIT

FCC CFR Title 47 Part 15 Subpart C Section 15.247 (a)(1):
 frequency hopping systems shall have hopping channel carrier frequencies separated by minimum of 25KHz or the $\frac{2}{3} * 20\text{dB}$ bandwidth of the hopping channel, whichever is greater.

TEST CONFIGURATION



TEST PROCEDURE

1. The transmitter output was connected to the spectrum analyzer through an attenuator.
2. The bandwidth of the fundamental frequency was measured by spectrum analyzer with RBW=30 KHz and VBW=100KHz.

TEST RESULTS

Modulation type	Channel	Carrier Frequencies Separation (MHz)	Limit (MHz)	Result
GFSK	40	1.000	0.808	Pass
$\pi/4$ DQPSK	40	1.000	0.763	Pass
8DPSK	40	1.000	0.777	Pass

Test plot as follows:

GFSK Modulation

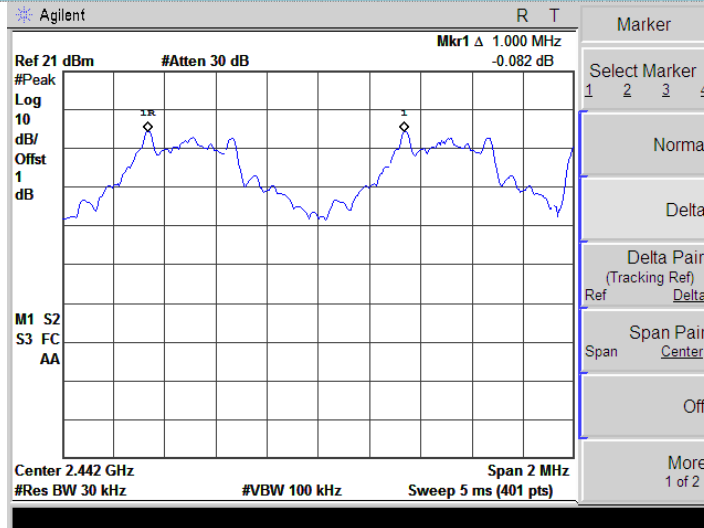

CH40

$\pi/4$ DQPSK Modulation

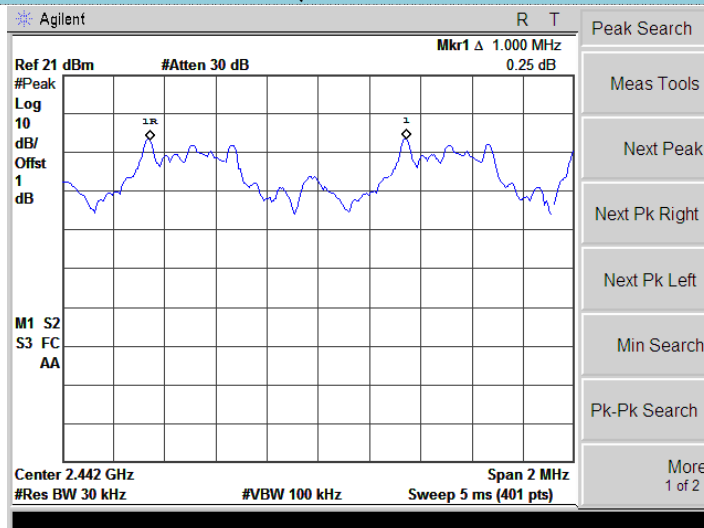

CH40

8DPSK Modulation

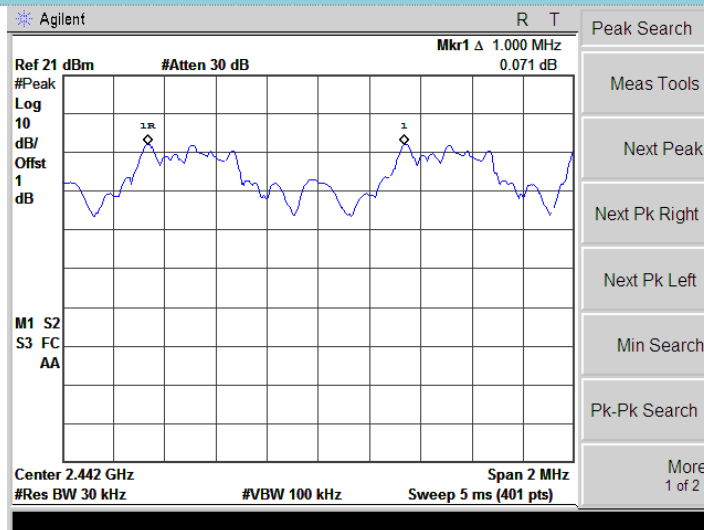

CH40

4.6. Hopping Channel Number

LIMIT

FCC CFR Title 47 Part 15 Subpart C Section 15.247 (a)(1):
 Frequency hopping systems in the 2400–2483.5 MHz band shall use at least **15** channels.

TEST CONFIGURATION



TEST PROCEDURE

1. The transmitter output was connected to the spectrum analyzer through an attenuator.
2. The bandwidth of the fundamental frequency was measured by spectrum analyzer with RBW=30 KHz and VBW=100KHz.

TEST RESULTS

Modulation type	Channel number	Limit (MHz)	Result
GFSK	79	15	Pass
$\pi/4$ DQPSK	79		
8DPSK	79		

Test plot as follows:

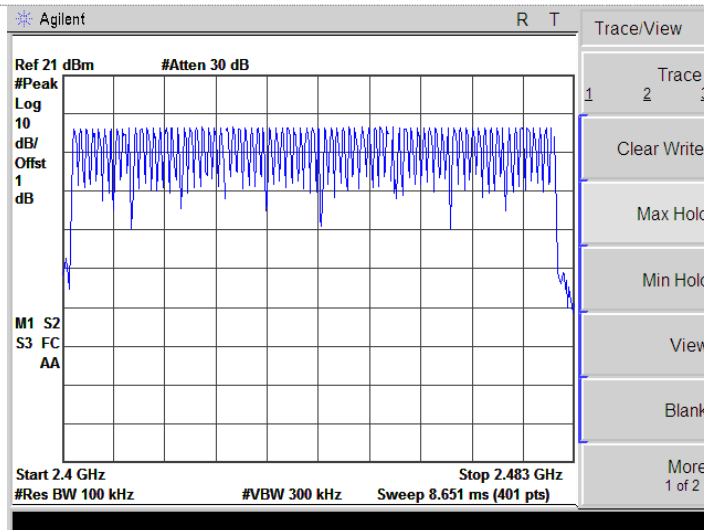

GFSK

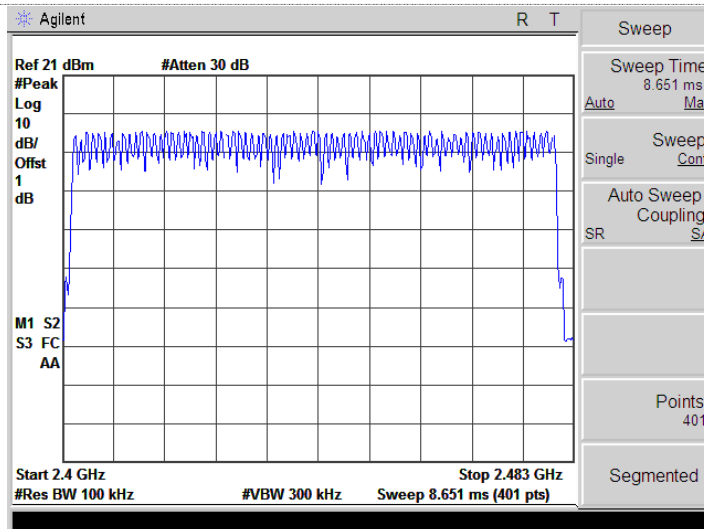

$\pi/4$ DQPSK

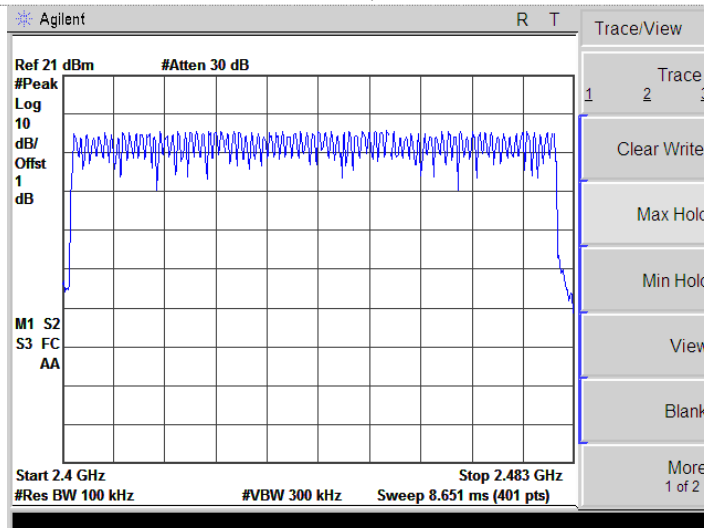

8DPSK

4.7. Dwell Time

LIMIT

FCC CFR Title 47 Part 15 Subpart C Section 15.247 (a)(1):

The average time of occupancy on any channel shall not be greater than 0.4 seconds within a pe-riod of 0.4 seconds multiplied by the number of hopping channels employed.

TEST CONFIGURATION



TEST PROCEDURE

1. The transmitter output was connected to the spectrum analyzer through an attenuator.
2. Set center frequency of spectrum analyzer=operating frequency with RBW=1MHz and VBW=3MHz,Span=0Hz.

TEST RESULTS

Modulation type	Channel	Dwell time (Second)	Limit (Second)	Result
GFSK	DH1	128	0.40	Pass
	DH3	263		
	DH5	312		
π/4DQPSK	2-DH1	128	0.40	Pass
	2-DH3	263		
	2-DH5	310		
8DPSK	3-DH1	128	0.40	Pass
	3-DH3	259		
	3-DH5	286		

Note:

1. We have tested all mode at high,middle and low channel,and recoreded worst case at middle channel.
2. Dwell time=Pulse time (ms) × (1600 ÷ 2 ÷ 79) ×31.6 Second for DH1, 2-DH1, 3-DH1
 Dwell time=Pulse time (ms) × (1600 ÷ 4 ÷ 79) ×31.6 Second for DH3, 2-DH3, 3-DH3
 Dwell time=Pulse time (ms) × (1600 ÷ 6 ÷ 79) ×31.6 Second for DH5, 2-DH5, 3-DH5

Test plot as follows:

GFSK Modulation

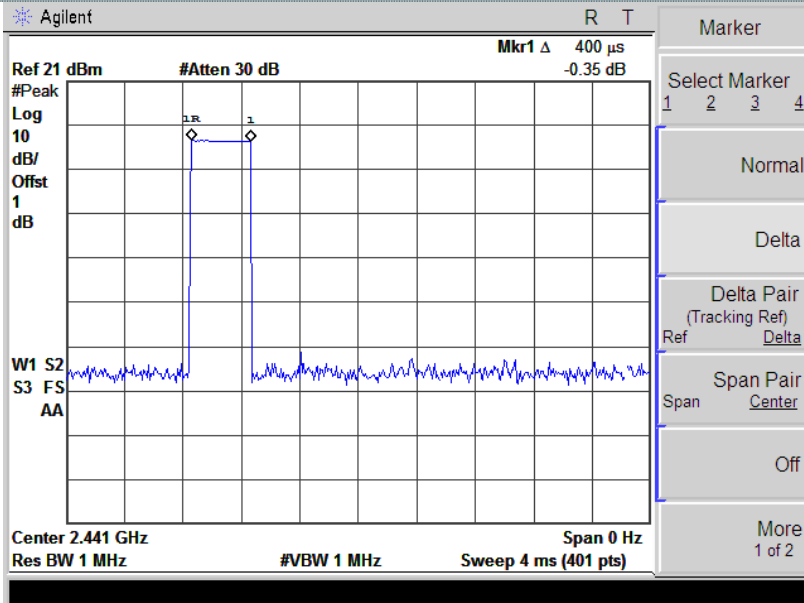

DH1

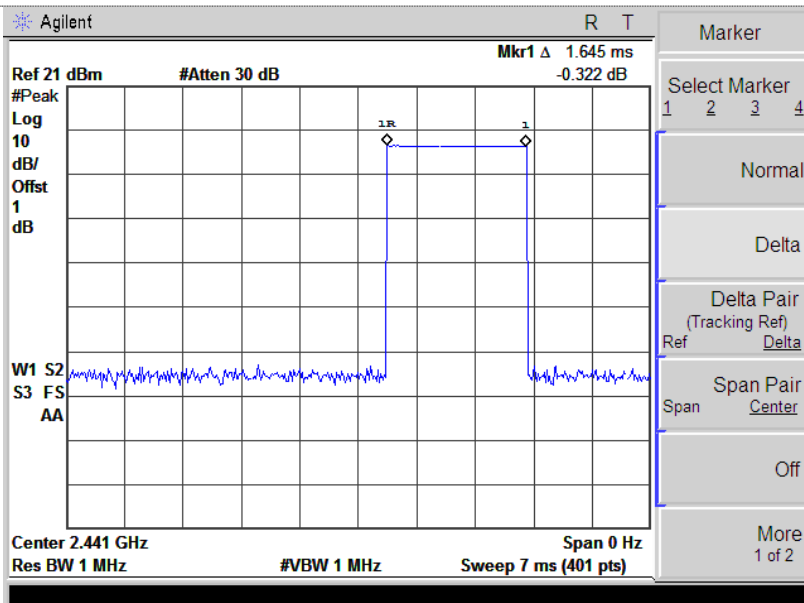

DH3

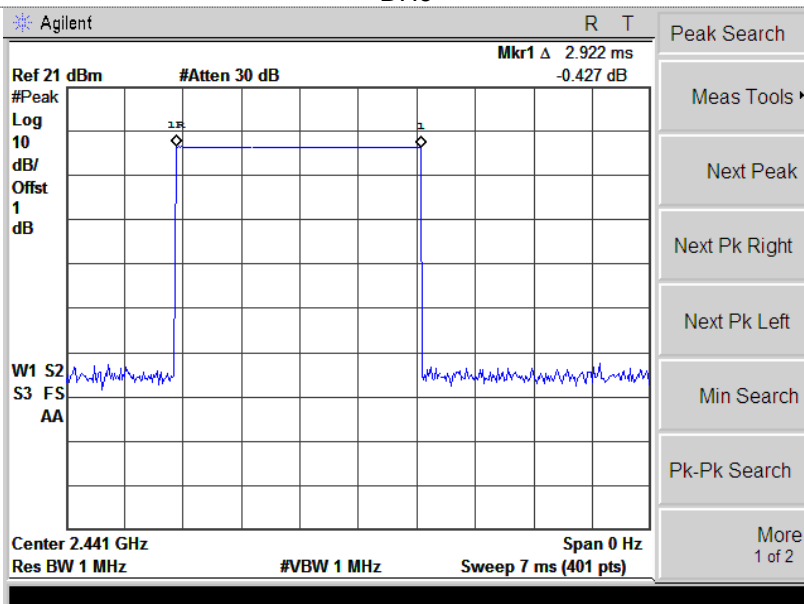

DH5

$\pi/4$ DQPSK Modulation

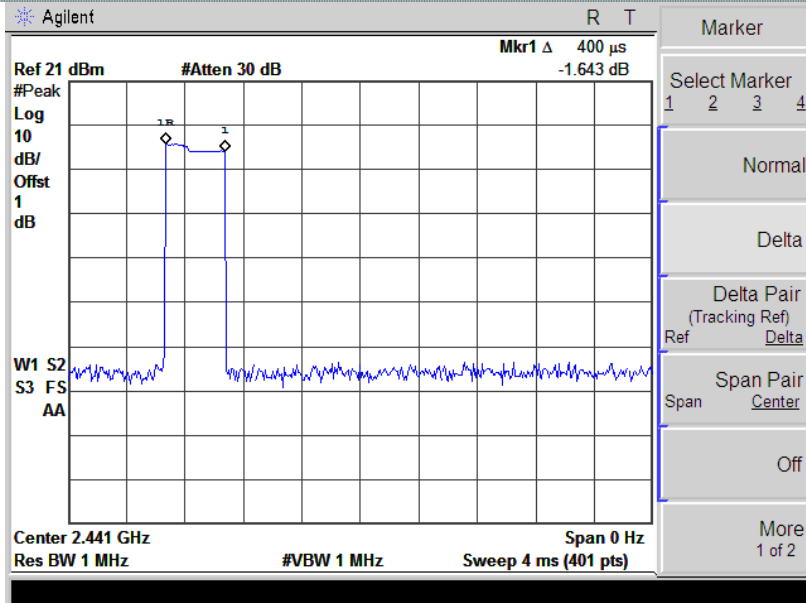

2-DH1

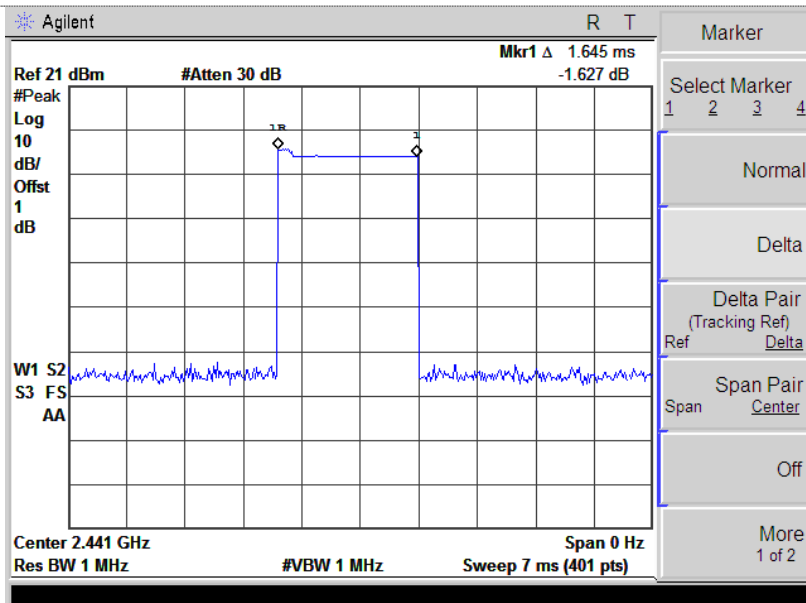

2-DH3

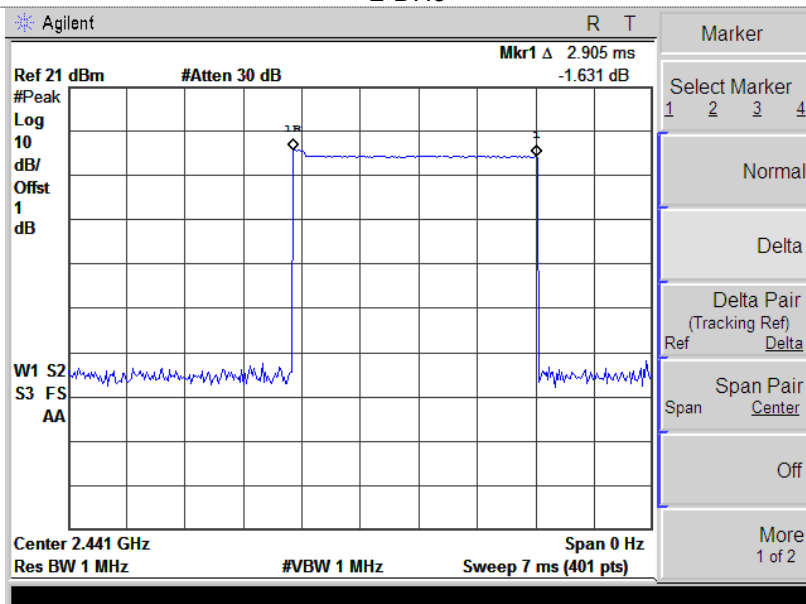

2-DH5

8DPSK Modulation

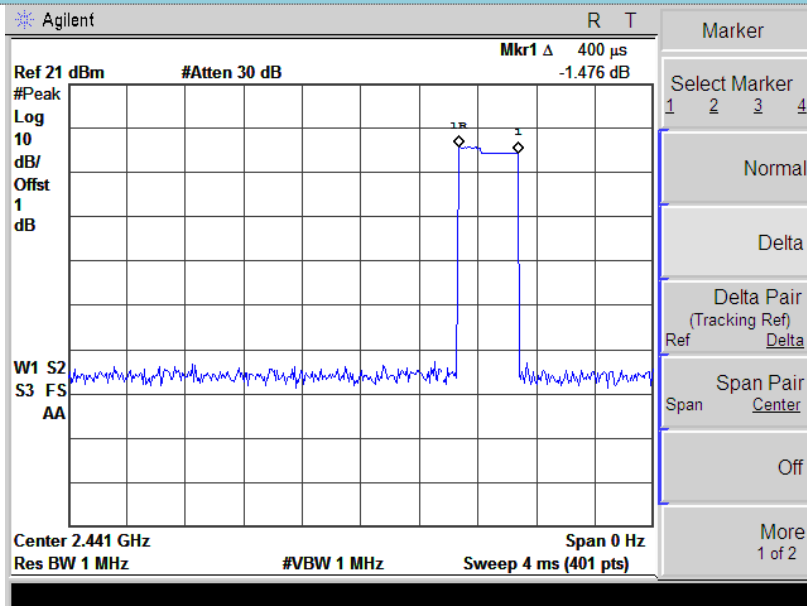

3-DH1

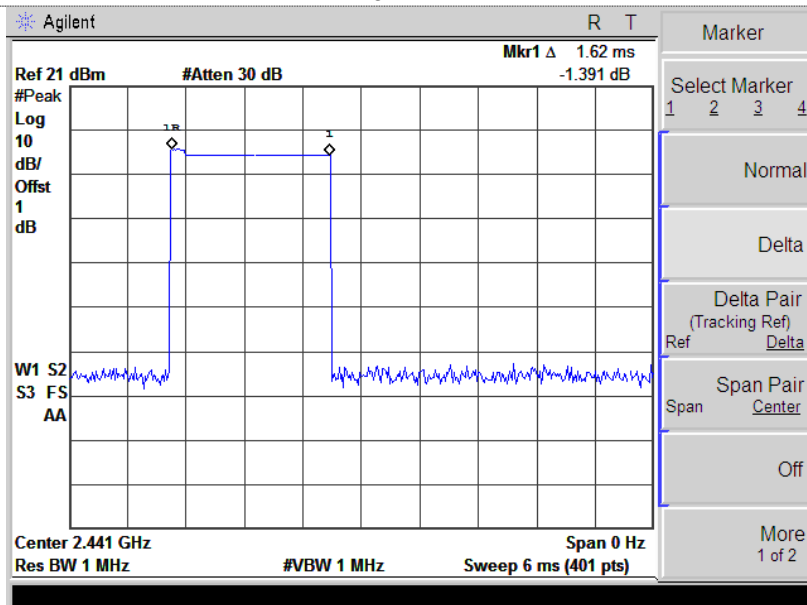

3-DH3

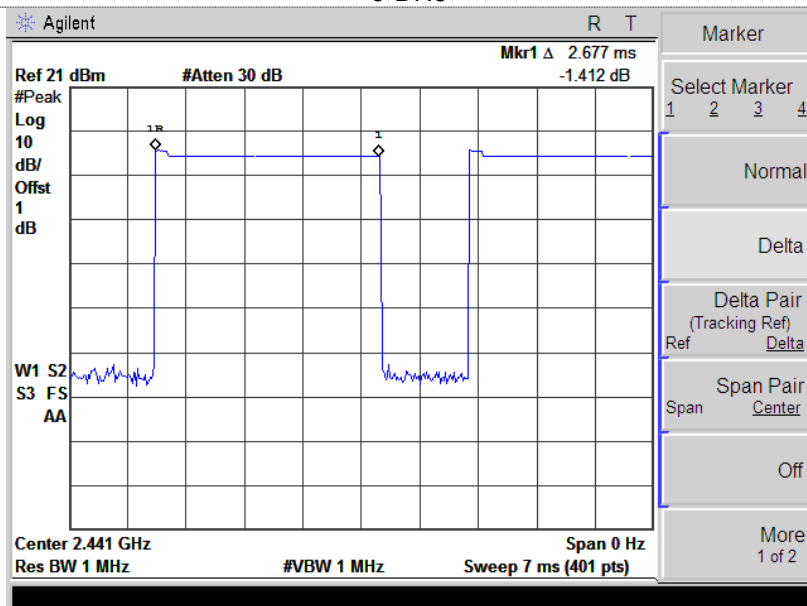

3-DH5

4.8. Pseudorandom Frequency Hopping Sequence

LIMIT

FCC CFR Title 47 Part 15 Subpart C Section 15.247 (a)(1):

Frequency hopping systems shall have hopping channel carrier frequencies separated by a minimum of 25 kHz or the 20 dB bandwidth of the hopping channel, whichever is greater. Alternatively, frequency hopping systems operating in the 2400–2483.5 MHz band may have hopping channel carrier frequencies that are separated by 25 kHz or two-thirds of the 20 dB bandwidth of the hopping channel, whichever is greater, provided the systems operate with an output power no greater than 125 mW. The system shall hop to channel frequencies that are selected at the system hopping rate from a pseudo randomly ordered list of hopping frequencies. Each frequency must be used equally on the average by each transmitter. The system receivers shall have input bandwidths that match the hopping channel bandwidths of their corresponding transmitters and shall shift frequencies in synchronization with the transmitted signals.

TEST RESULTS

The pseudorandom frequency hopping sequence may be generated in a nine-stage shift register whose 5th and 9th stage outputs are added in a modulo-two addition stage. And the result is fed back to the input of the first stage. The sequence begins with the first one of 9 consecutive ones, for example: the shift register is initialized with nine ones.

- Number of shift register stages:9
- Length of pseudo-random sequence:2⁹-1=511 bits
- Longest sequence of zeros:8(non-inverted signal)

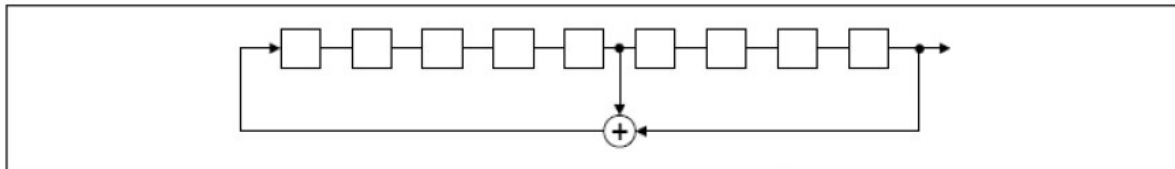

Linear Feedback Shift Register for Generation of the PRBS sequence

An example of pseudorandom frequency hopping sequence as follows:

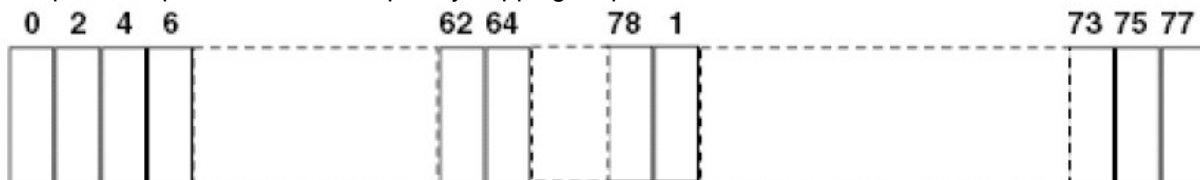

Each frequency used equally on the average by each transmitter. The system receiver has input bandwidths that match the hopping channel bandwidths of their corresponding transmitter and shifts frequencies in synchronization with the transmitted signals.

4.9. Band Edge

LIMIT

FCC CFR Title 47 Part 15 Subpart C Section 15.247 (d):

In any 100 kHz bandwidth outside the frequency band in which the spread spectrum intentional radiator is operating, the radio frequency power that is produced by the intentional radiator shall be at least 20 dB below that in the 100 kHz bandwidth within the band that contains the highest level of the desired power, based on either an RF conducted or a radiated measurement.

TEST CONFIGURATION

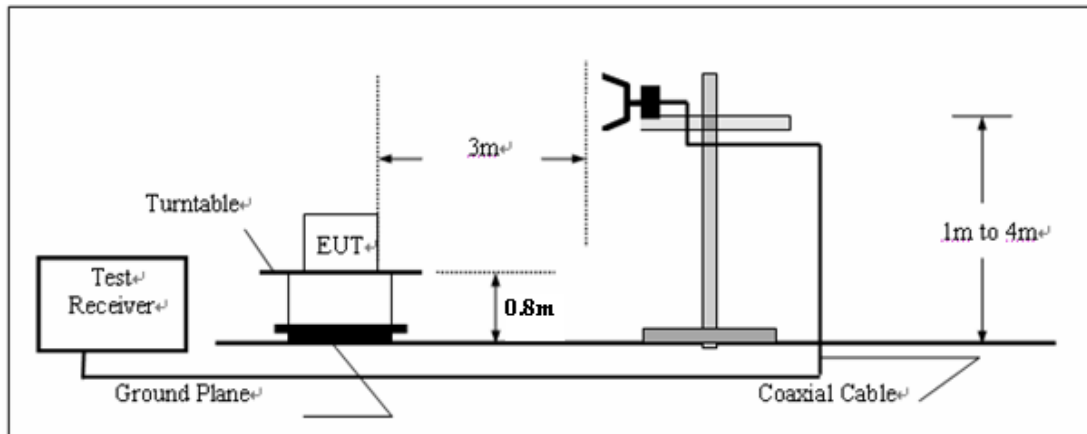

TEST PROCEDURE

1. The EUT was placed on a turn table which is 0.8m above ground plane.
2. Maximum procedure was performed by raising the receiving antenna from 1m to 4m and rotating the turn table from 0° to 360° to acquire the highest emissions from EUT
3. And also, each emission was to be maximized by changing the polarization of receiving antenna both horizontal and vertical.
4. Repeat above procedures until all frequency measurements have been completed.
5. For Frequencies below 1 GHz, RBW= 120 kHz, testing was performed with CISPR16 compliant test receiver with QP detector. Above 1 GHz tests were performed using a spectrum analyser using the following settings:
Peak RBW=VBW= 1MHz
Average RBW 1MHz , VBW=10Hz
6. These settings as per ANSI C63.10

TEST RESULTS

Noted:

Have pre-scan all modulation mode, found the 8DPSK modulation which it was worst case, so only the worst case's data on the test report.

For Radiated Bandedge Measurement

Worst mode:	8DPSK Modulation	Test Channel:	01
Detector:	Peak	Polarization:	Horizontal

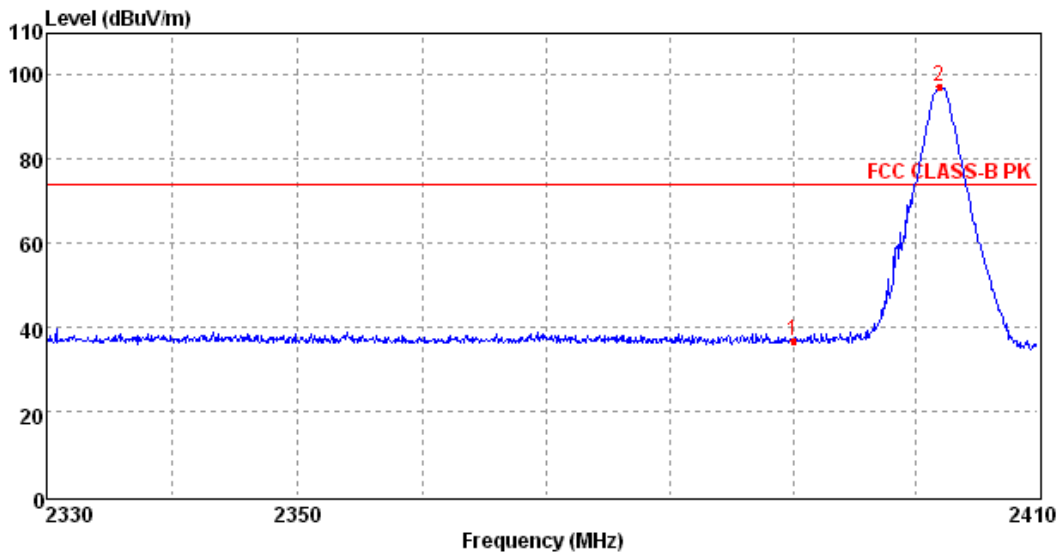

Mark	Frequency (MHz)	Level (dBuV/m)	Cable Loss (dB)	Antenna Factor (dB/m)	Preamp Factor (dB)	Reading Level (dBuV/m)	Limit (dBuV/m)	Margin (dB)	Detector
1	2390.00	44.76	3.32	27.49	36.12	39.45	74.00	-34.55	Peak
2	2402.78	103.85	3.32	27.49	36.12	98.54			Peak

Worst mode:	8DPSK Modulation	Test Channel:	01
Detector:	Peak	Polarization:	Vertical

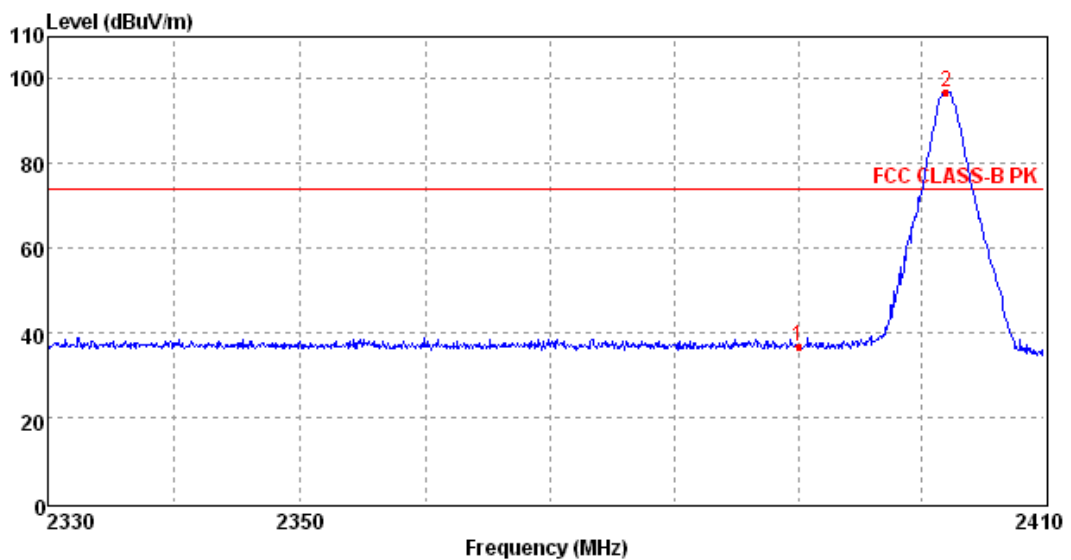

Mark	Frequency (MHz)	Level (dBuV/m)	Cable Loss (dB)	Antenna Factor (dB/m)	Preamp Factor (dB)	Reading Level (dBuV/m)	Limit (dBuV/m)	Margin (dB)	Detector
1	2390.00	53.65	3.32	27.49	36.12	48.34	74.00	-25.66	Peak
2	2402.78	102.96	3.32	27.49	36.12	97.65			Peak

Worst mode:	8DPSK Modulation	Test Channel:	01
Detector:	Average	Polarization:	Horizontal

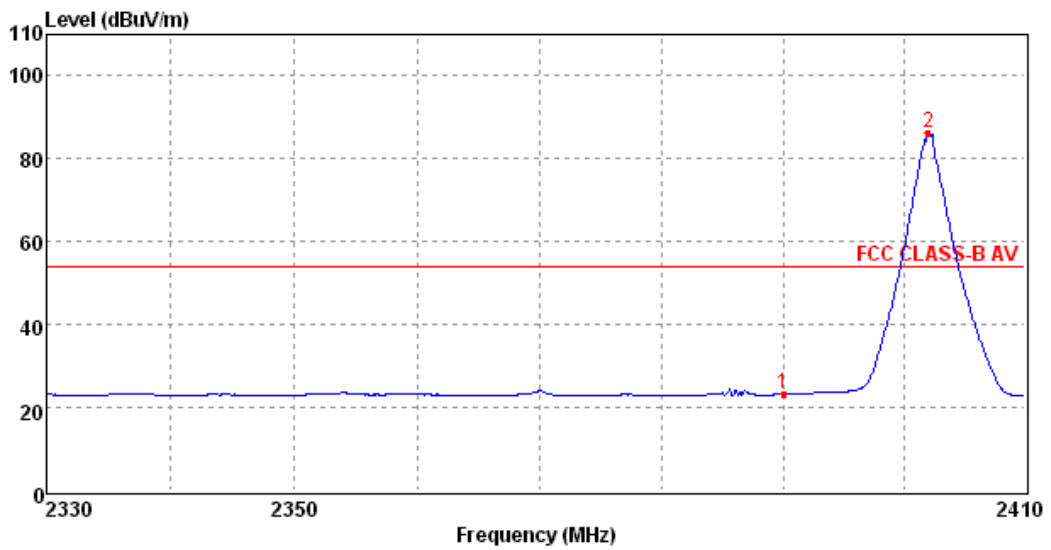

Mark	Frequency (MHz)	Level (dBuV/m)	Cable Loss (dB)	Antenna Factor (dB/m)	Preamp Factor (dB)	Reading Level (dBuV/m)	Limit (dBuV/m)	Margin (dB)	Detector
1	2390.00	27.87	3.32	27.49	36.12	22.56	54.00	-31.44	Average
2	2402.78	92.96	3.32	27.49	36.12	87.65			Average

Worst mode:	8DPSK Modulation	Test Channel:	01
Detector:	Average	Polarization:	Vertical

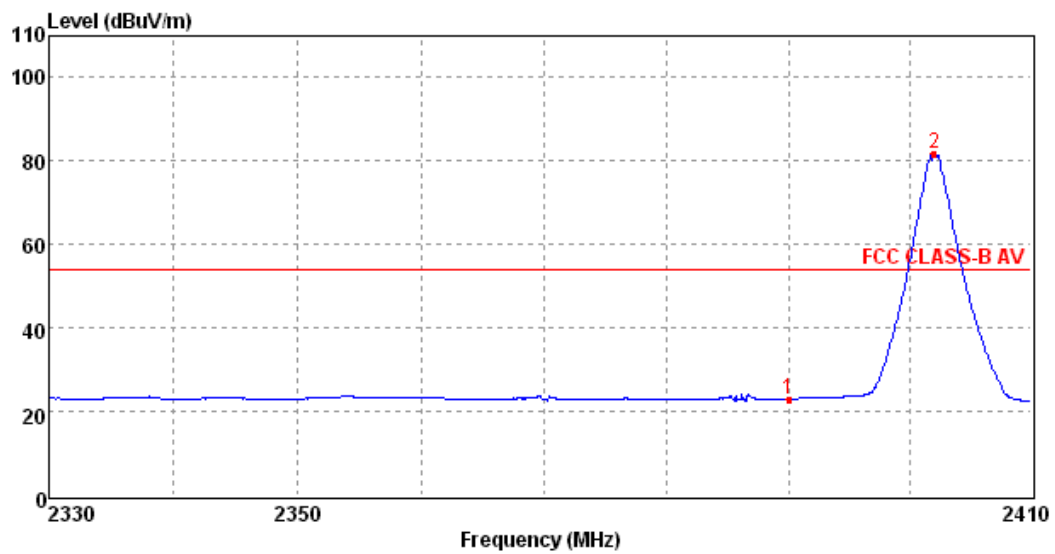

Mark	Frequency (MHz)	Level (dBuV/m)	Cable Loss (dB)	Antenna Factor (dB/m)	Preamp Factor (dB)	Reading Level (dBuV/m)	Limit (dBuV/m)	Margin (dB)	Detector
1	2390.00	28.76	3.32	27.49	36.12	23.45	54.00	-30.55	Average
2	2402.78	87.74	3.32	27.49	36.12	82.43			Average

Worst mode:	8DPSK Modulation	Test Channel:	79
Detector:	Peak	Polarization:	Horizontal

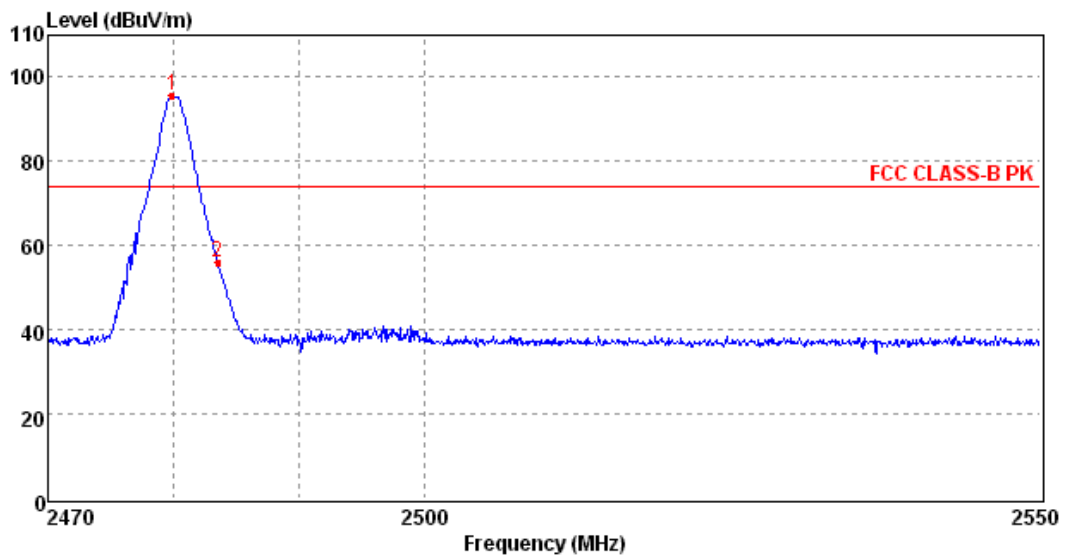

Mark	Frequency (MHz)	Level (dBuV/m)	Cable Loss (dB)	Antenna Factor (dB/m)	Preamp Factor (dB)	Reading Level (dBuV/m)	Limit (dBuV/m)	Margin (dB)	Detector
1	2479.78	98.69	3.88	27.45	36.55	93.47			Peak
2	2483.50	61.57	3.88	27.45	36.55	56.35	74.00	17.65	Peak

Worst mode:	8DPSK Modulation	Test Channel:	79
Detector:	Peak	Polarization:	Vertical

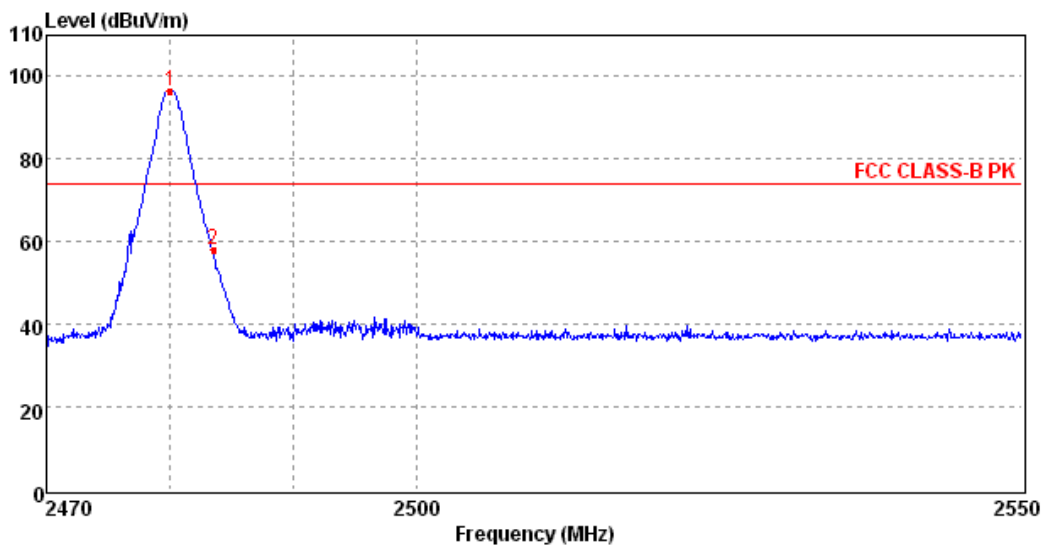

Mark	Frequency (MHz)	Level (dBuV/m)	Cable Loss (dB)	Antenna Factor (dB/m)	Preamp Factor (dB)	Reading Level (dBuV/m)	Limit (dBuV/m)	Margin (dB)	Detector
1	2479.86	100.76	3.88	27.45	36.55	95.54			Peak
2	2483.50	63.65	3.88	27.45	36.55	58.43	74.00	-15.57	Peak

Worst mode:	8DPSK Modulation	Test Channel:	79
Detector:	Average	Polarization:	Horizontal

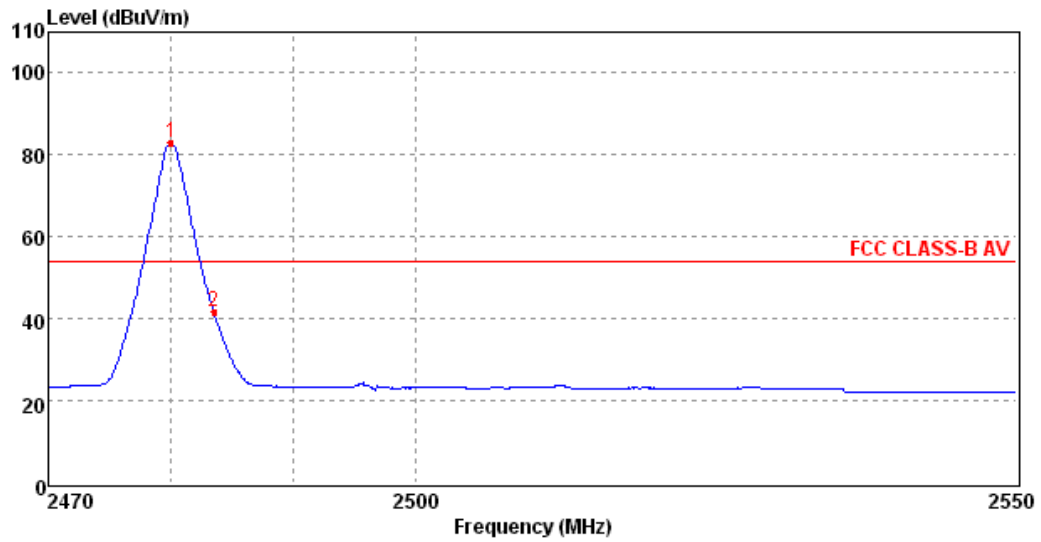

Mark	Frequency (MHz)	Level (dBuV/m)	Cable Loss (dB)	Antenna Factor (dB/m)	Preamp Factor (dB)	Reading Level (dBuV/m)	Limit (dBuV/m)	Margin (dB)	Detector
1	2480.36	89.57	3.88	27.45	36.55	84.35			Average
2	2483.50	47.96	3.88	27.45	36.55	42.74	54.00	-11.26	Average

Worst mode:	8DPSK Modulation	Test Channel:	79
Detector:	Average	Polarization:	Vertical

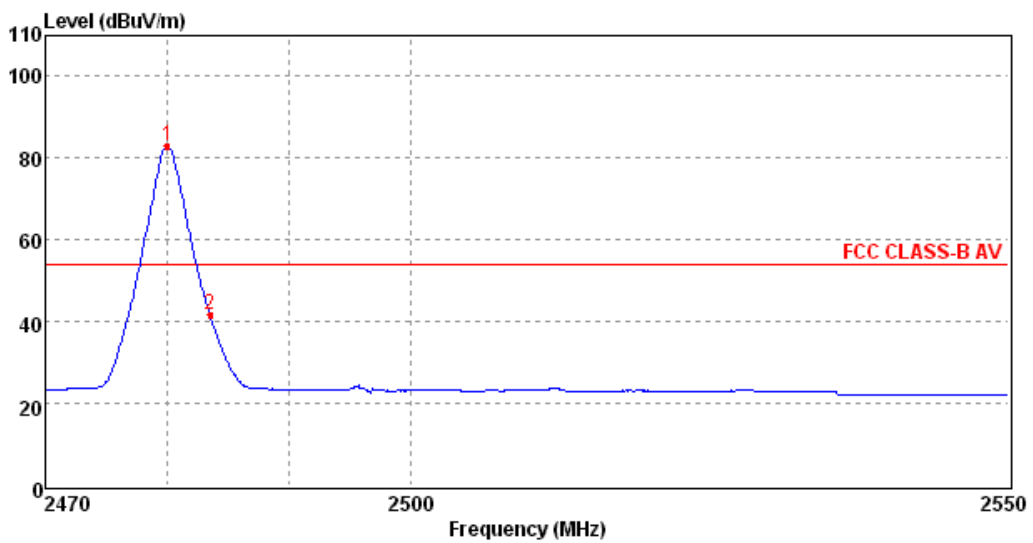

Mark	Frequency (MHz)	Level (dBuV/m)	Cable Loss (dB)	Antenna Factor (dB/m)	Preamp Factor (dB)	Reading Level (dBuV/m)	Limit (dBuV/m)	Margin (dB)	Detector
1	2480.36	88.96	3.88	27.45	36.55	83.74			Average
2	2483.50	48.91	3.88	27.45	36.55	43.69	54.00	-10.31	Average

For Conducted Bandedge Measurement

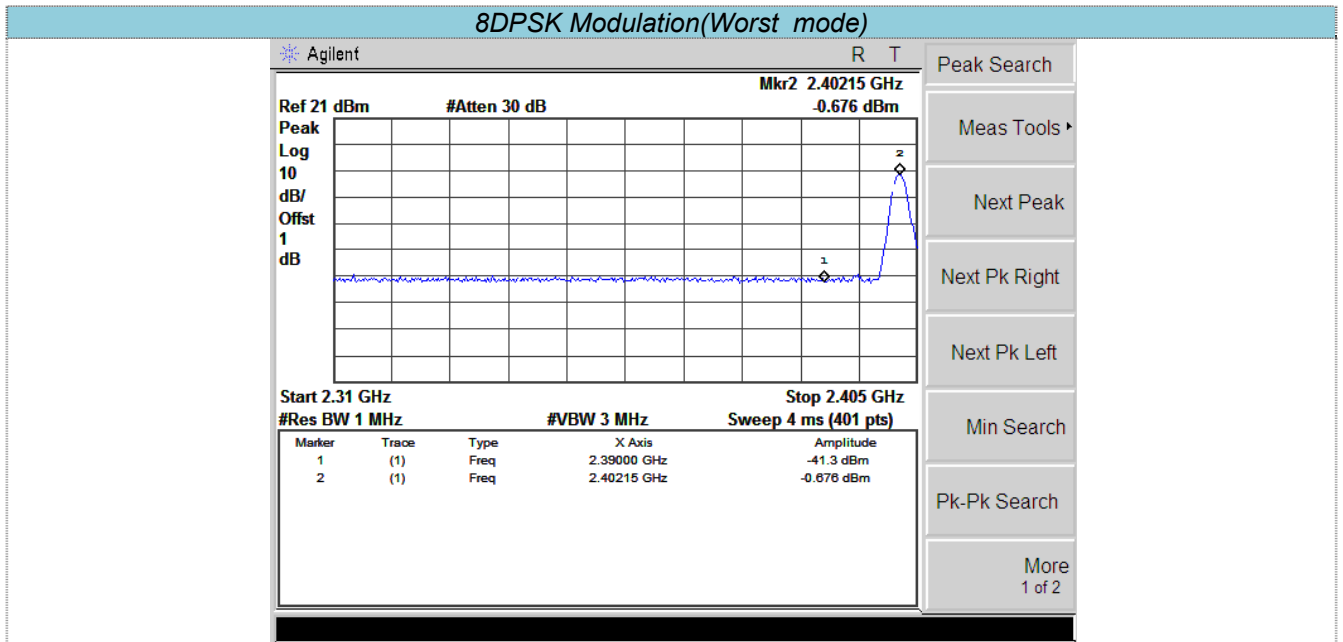

CH01

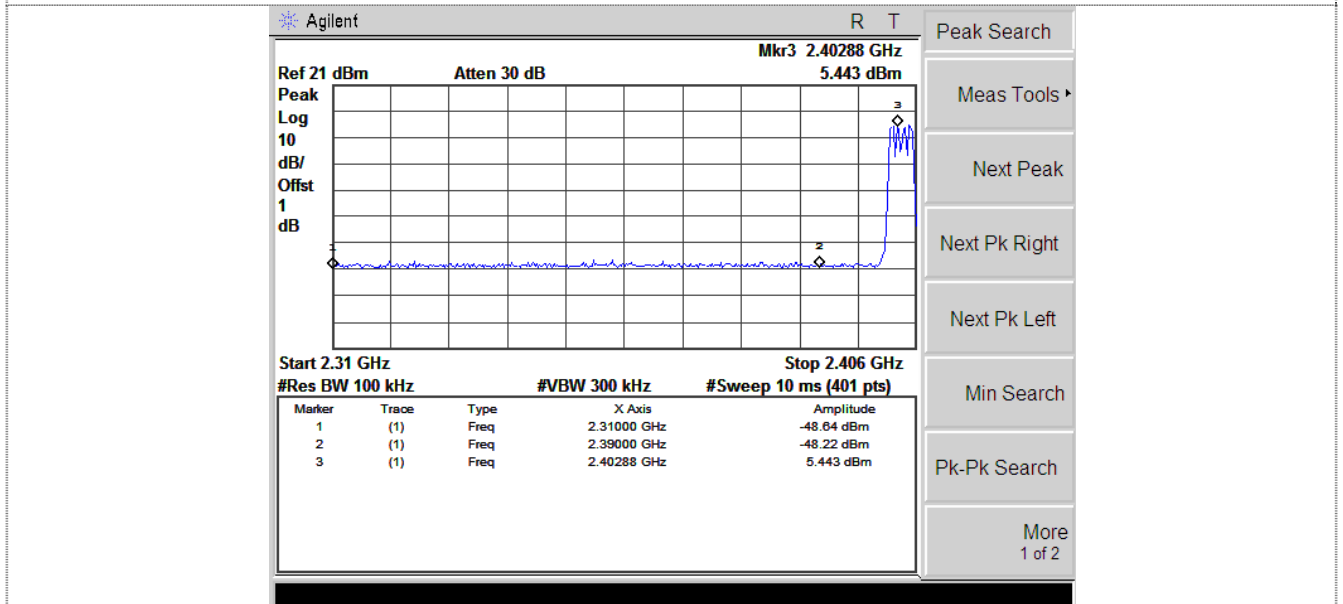

CH01

8DPSK Modulation(Worst mode)

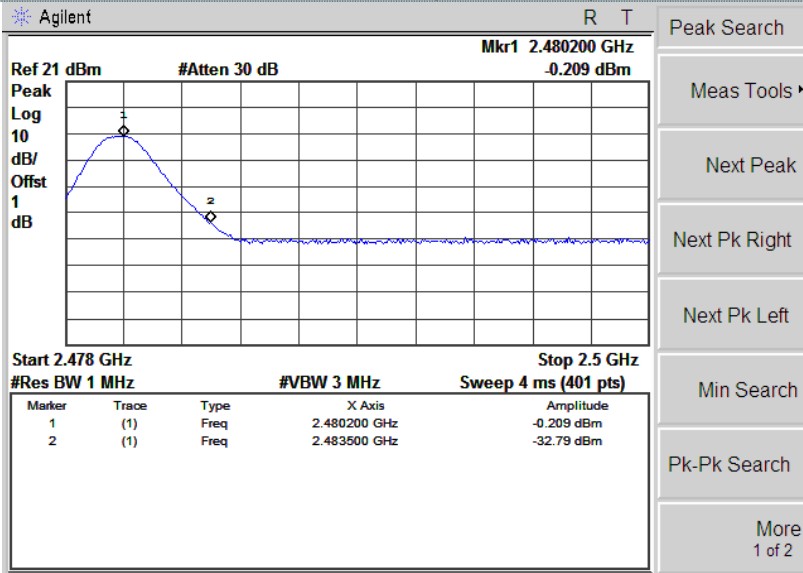

CH79

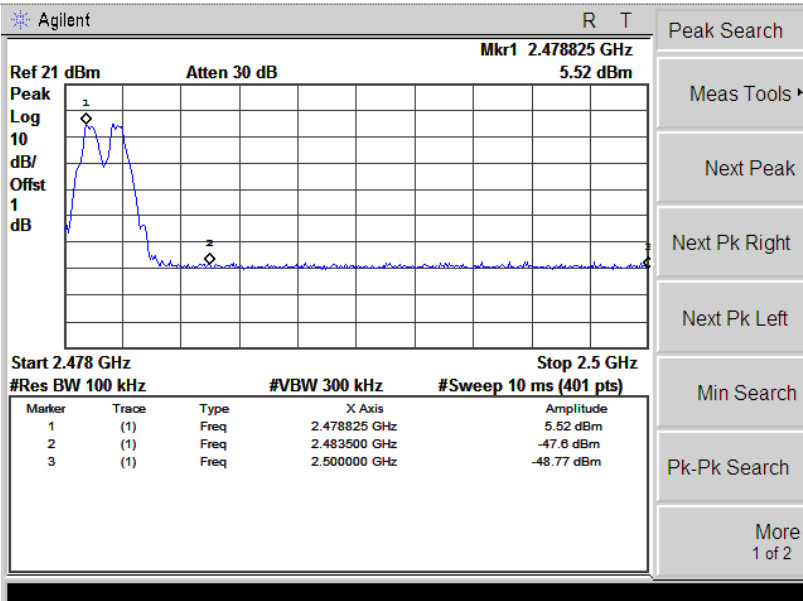

CH79

4.10. Spurious Emission (conducted)

LIMIT

FCC CFR Title 47 Part 15 Subpart C Section 15.247 (d):

In any 100 kHz bandwidth outside the frequency band in which the spread spectrum intentional radiator is operating, the radio frequency power that is produced by the intentional radiator shall be at least 20 dB below that in the 100 kHz bandwidth within the band that contains the highest level of the desired power, based on either an RF conducted or a radiated measurement.

TEST CONFIGURATION



TEST PROCEDURE

1. The transmitter output was connected to the spectrum analyzer through an attenuator.
2. The bandwidth of the fundamental frequency was measured by spectrum analyzer with RBW=100 KHz and VBW=300KHz.
3. Below -20dB of the highest emission level in operating band.

TEST RESULTS

Noted:

Have pre-scan all modulation mode, found the 8DPSK modulation which it was worst case, so only the worst case's data on the test report.

Test plot as follows:

Test channel

01

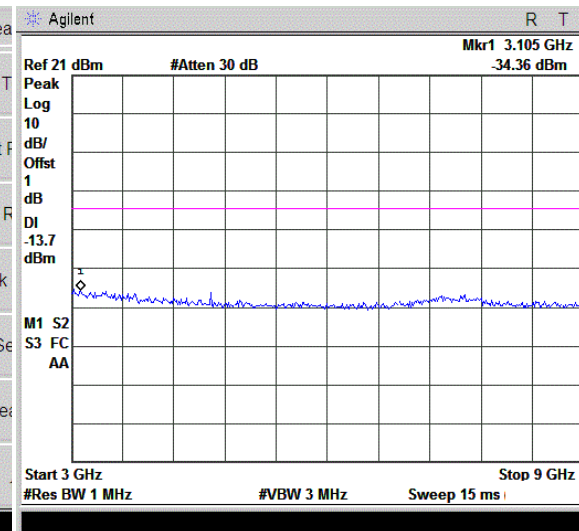
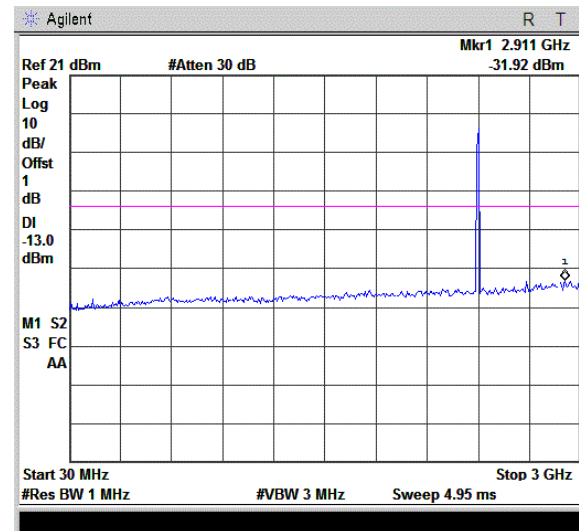

30MHz~3GHz

3GHz~9GHz

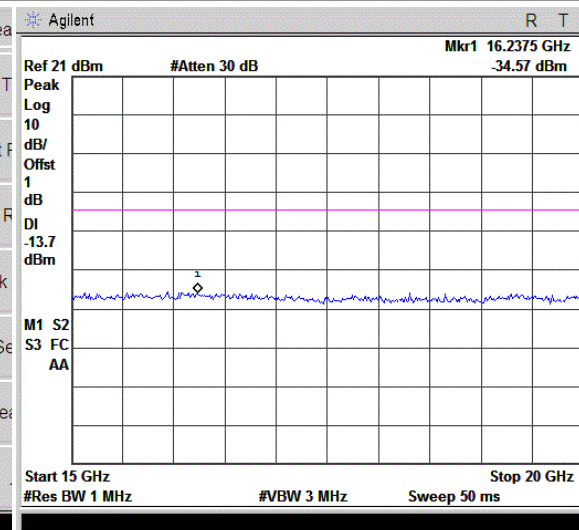
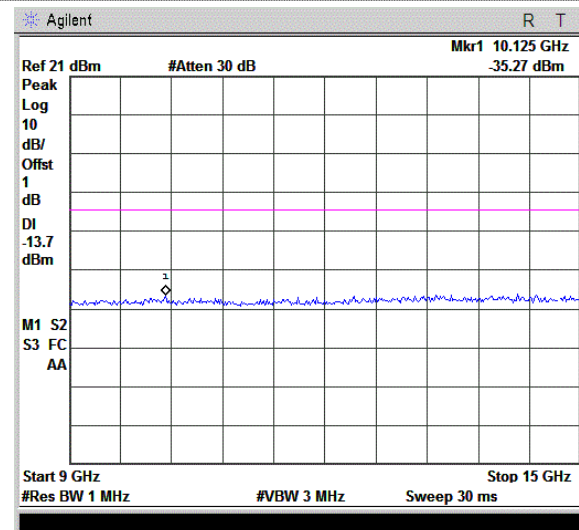

9GHz~15GHz

15GHz~20GHz

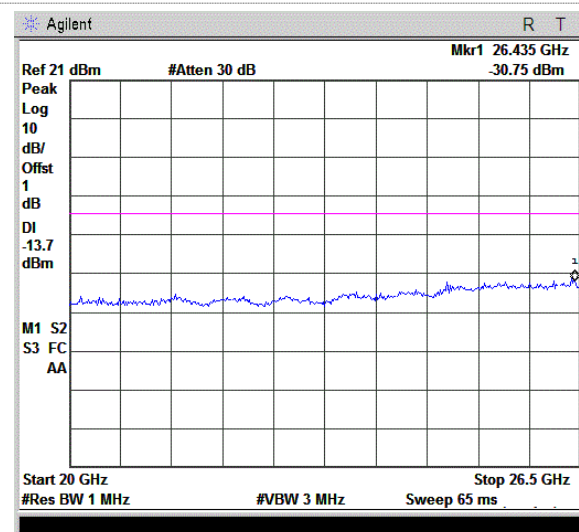

20GHz~26.5GHz

Test channel

40

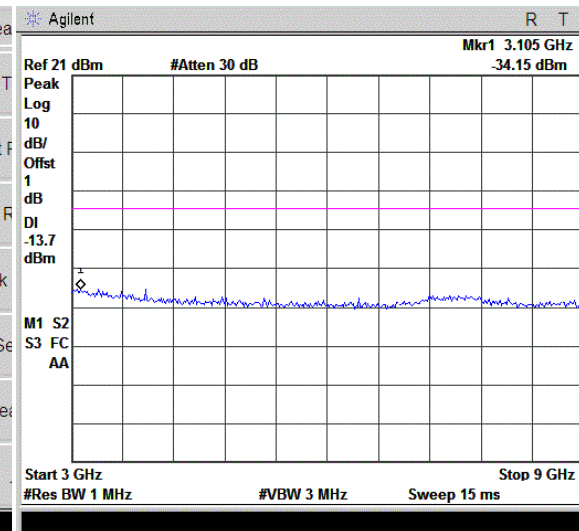
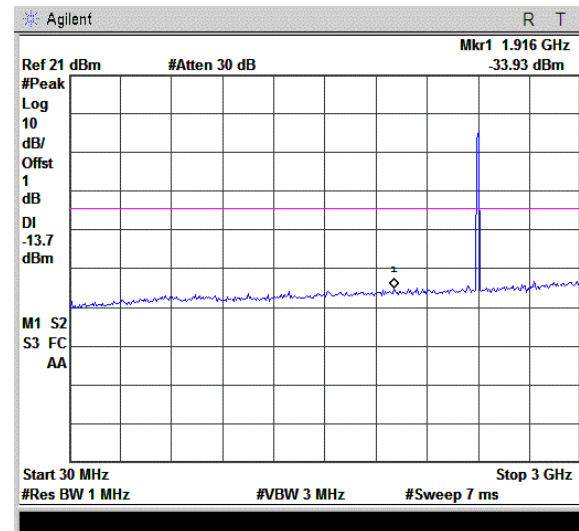

30MHz~3GHz

3GHz~9GHz

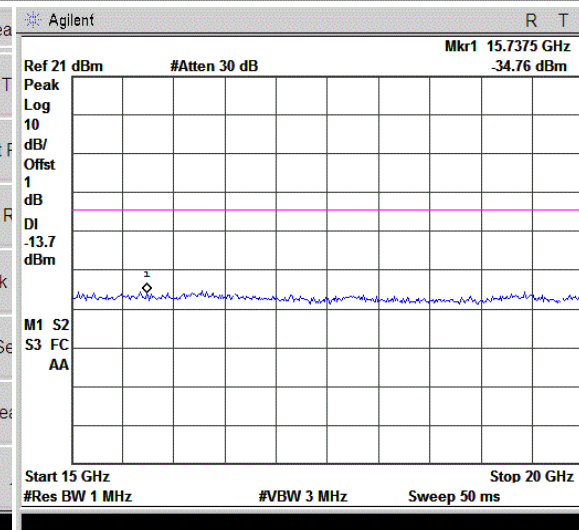
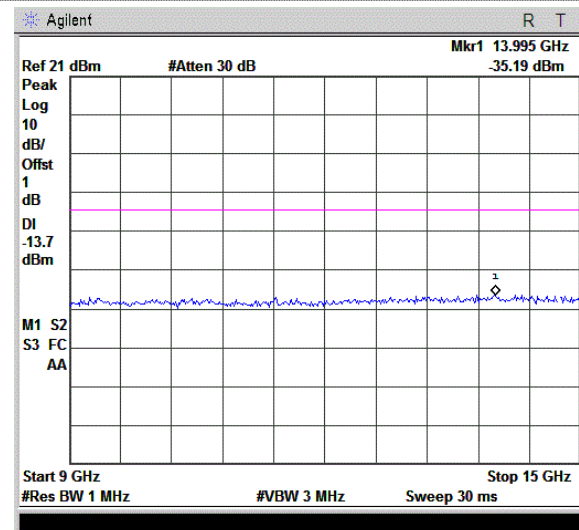

9GHz~15GHz

15GHz~20GHz

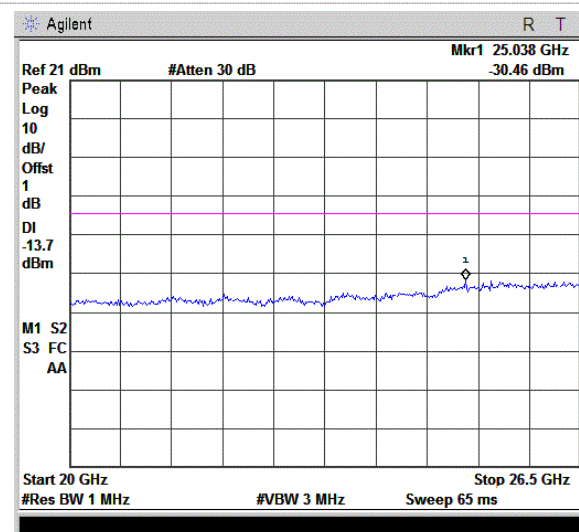

20GHz~26.5GHz

Test channel

79

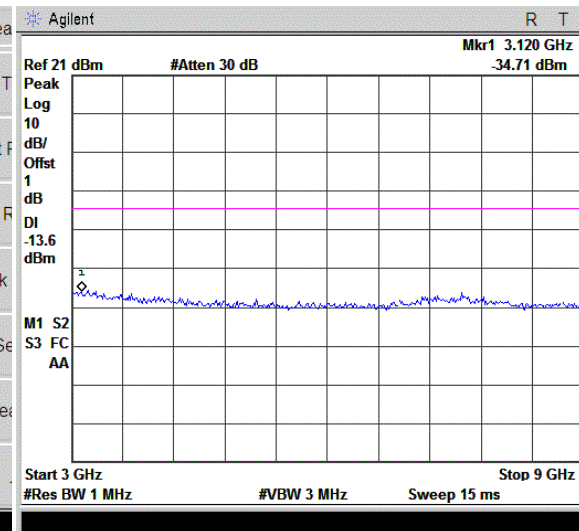
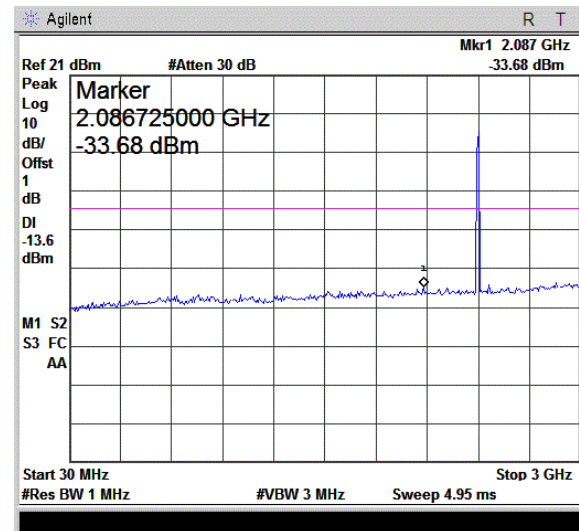

30MHz~3GHz

3GHz~9GHz

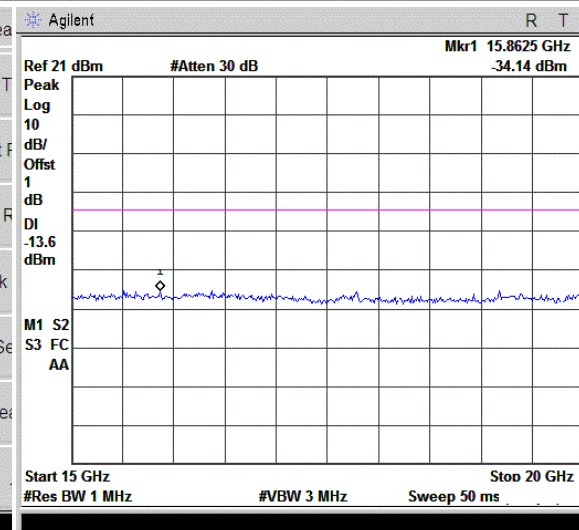
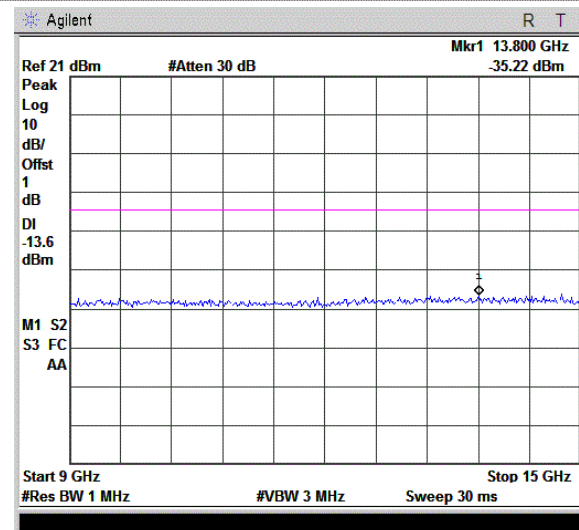

9GHz~15GHz

15GHz~20GHz

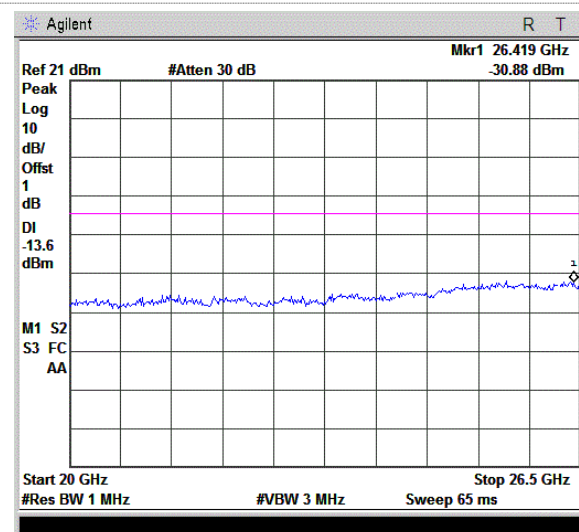

20GHz~26.5GHz

4.11. Spurious Emission (radiated)

LIMIT

FCC CFR Title 47 Part 15 Subpart C Section 15.209

Frequency	Limit (dBuV/m @3m)	Value
30MHz-88MHz	40.00	Quasi-peak
88MHz-216MHz	43.50	Quasi-peak
216MHz-960MHz	46.00	Quasi-peak
960MHz-1GHz	54.00	Quasi-peak
Above 1GHz	54.00	Average
	74.00	Peak

TEST CONFIGURATION

- Below 30MHz

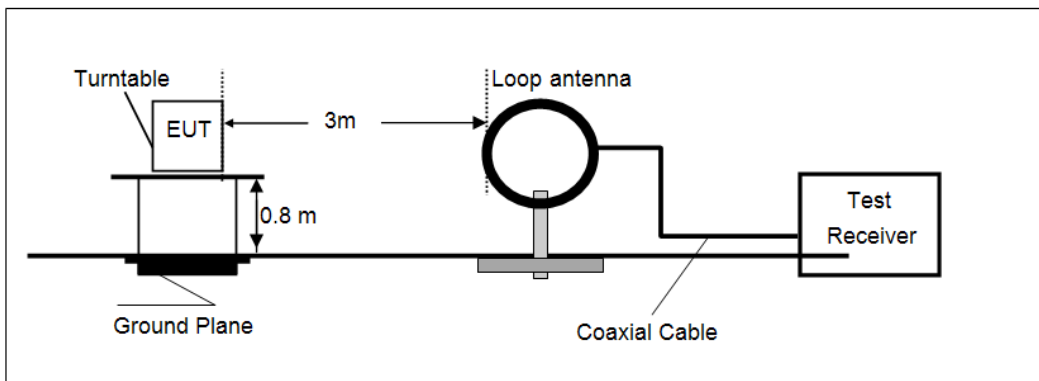

- 30MHz~1000MHz

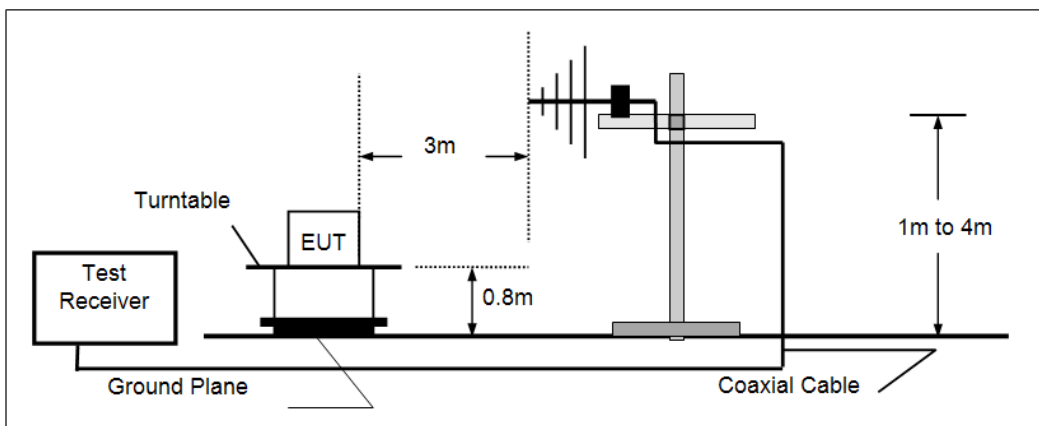

- Above 1GHz

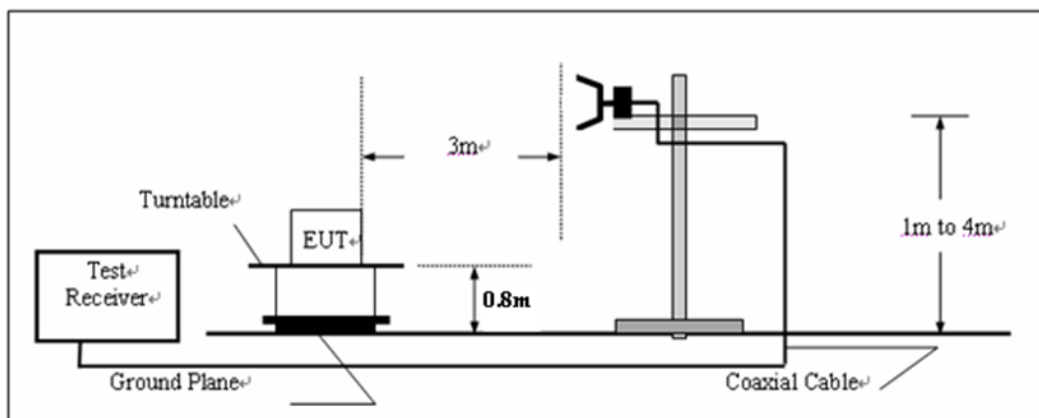

TEST PROCEDURE

1. The EUT was placed on the top of a rotating table 0.8 meters above the ground at a 3 meter camber. The table was rotated 360 degrees to determine the position of the highest radiation.
2. The EUT was set 3 meters away from the interference-receiving antenna, which was mounted on the top of a variable-height antenna tower.
3. The antenna height is varied from one meter to four meters above the ground to determine the maximum value of the field strength. Both horizontal and vertical polarizations of the antenna are set to make the measurement.
4. For each suspected emission, the EUT was arranged to its worst case and then the antenna was tuned to heights from 1 meter to 4 meters and the rota table was turned from 0 degrees to 360 degrees to find the maximum reading.
5. The test-receiver system was set to Peak Detect Function and Specified Bandwidth with Maximum Hold Mode.
6. For Frequencies below 1 GHz, RBW= 120 kHz, testing was performed with CISPR16 compliant test receiver with QP detector. Above 1 GHz tests were performed using a spectrum analyser using the following settings:
Peak RBW=VBW= 1MHz
Average RBW 1MHz , VBW=10Hz
7. These settings as per ANSI C63.10

TEST RESULTS

Noted:

Have pre-scan all modulation mode, found the GFSK modulation which it was worst case, so only the worst case's data on the test report.

For 9KHz to 30MHz

Frequency (MHz)	Level (dBuV/m)@3m	Limit Line (dBuV/m)@3m	Margin (dB)	Detector	Result
13.39	43.34	69.54	-26.2	QP	PASS
24.72	41.58	69.54	-27.96	QP	PASS

Measurement data:

■ Below 1GHz

SWEEP TABLE: "test (30M-1G)"

Short Description:		Field Strength			
Start	Stop	Detector	Meas. Time	IF Bandw.	Transducer
Frequency	Frequency				
30.0 MHz	1.1 GHz	MaxPeak	Coupled	100 kHz	VULB9163

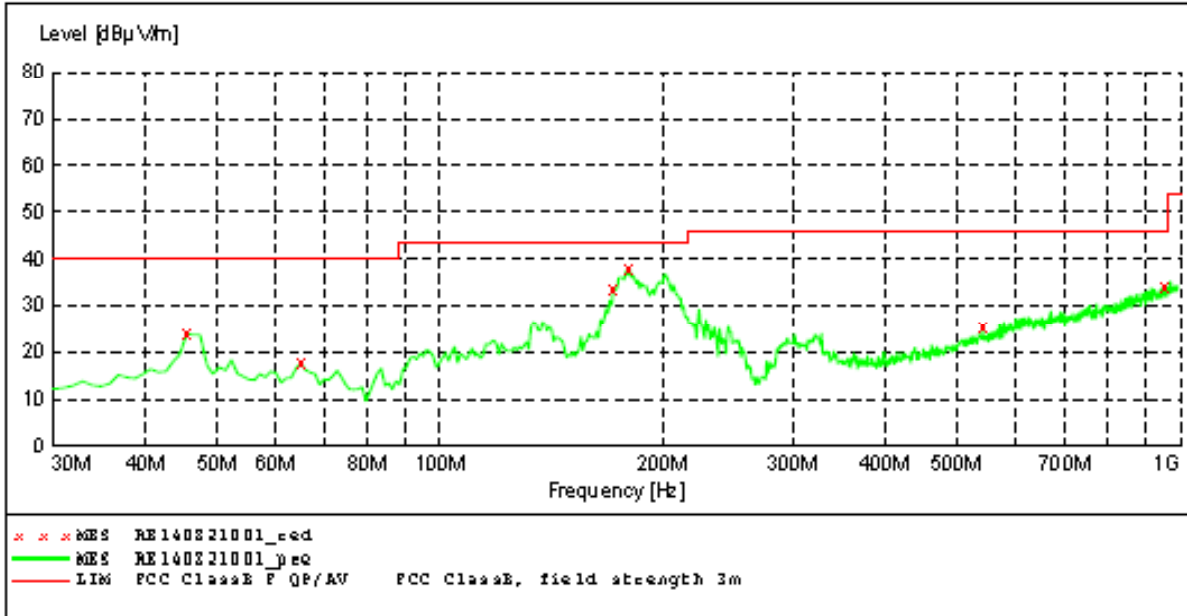

MEASUREMENT RESULT: "RE140821001_red"

8/21/2014 11:28AM

Frequency MHz	Level dBµV/m	Transd dB	Limit dBµV/m	Margin dB	Det.	Height cm	Azimuth deg	Polarization
45.520000	23.80	-15.0	40.0	16.2	QP	300.0	283.00	HORIZONTAL
64.920000	17.60	-17.4	40.0	22.4	QP	300.0	141.00	HORIZONTAL
171.620000	33.70	-16.7	43.5	9.8	QP	100.0	88.00	HORIZONTAL
180.350000	37.80	-15.9	43.5	5.7	QP	300.0	79.00	HORIZONTAL
541.190000	25.50	-5.6	46.0	20.5	QP	300.0	360.00	HORIZONTAL
954.410000	33.90	3.5	46.0	12.1	QP	100.0	135.00	HORIZONTAL

SWEEP TABLE: "test (30M-1G)"

Short Description:		Field Strength			
Start	Stop	Detector	Meas. Time	IF Bandw.	Transducer
30.0 MHz	1.1 GHz	MaxPeak	Coupled	100 kHz	VULB9163

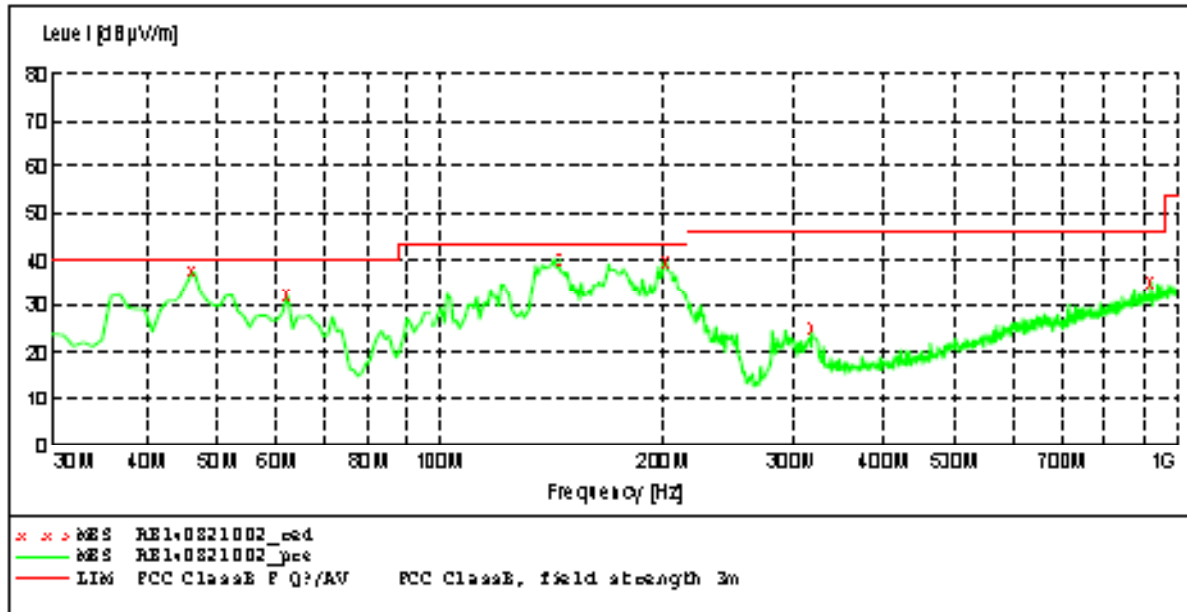

MEASUREMENT RESULT: "RE140821002_red"

8/21/2014 11:32AM

Frequency MHz	Level dBµV/m	Transd dB	Limit dBµV/m	Margin dB	Det.	Height cm	Asimuth deg	Polarization
46.490000	37.50	-15.1	40.0	2.5	QP	100.0	5.00	VERTICAL
62.010000	32.00	-16.4	40.0	8.0	QP	100.0	5.00	VERTICAL
145.430000	40.50	-18.4	43.5	3.0	QP	100.0	114.00	VERTICAL
202.660000	39.60	-14.6	43.5	3.9	QP	100.0	154.00	VERTICAL
319.060000	25.30	-13.3	46.0	20.7	QP	100.0	350.00	VERTICAL
921.430000	35.10	3.0	46.0	10.9	QP	100.0	336.00	VERTICAL

■ Above 1GHz

Test channel:	01
---------------	----

Peak value:

Frequency (MHz)	Read Level (dBuV)	Antenna Factor (dB/m)	Cable Loss (dB)	Preamplifier Factor (dB)	Level (dBuV/m)	Limit Line (dBuV/m)	Over Limit (dB)	Polarization
4804	43.13	31.28	5.66	35.29	44.78	74	-29.22	Vertical
7206	39.64	36.22	6.87	35.15	47.58	74	-26.42	Vertical
9608	38.53	37.85	8.8	35.55	49.63	74	-24.37	Vertical
12010	38.94	38.25	8.9	35.84	50.25	74	-23.75	Vertical
14412	39.44	39.25	9.2	36.15	51.74	74	-22.26	Vertical
4804	43.09	31.28	5.66	35.29	44.74	74	-29.26	Horizontal
7206	39.08	36.22	6.87	35.15	47.02	74	-26.98	Horizontal
9608	38.77	37.85	8.8	35.55	49.87	74	-24.13	Horizontal
12010	38.94	38.25	8.9	35.84	50.25	74	-23.75	Horizontal
14412	40.09	39.25	9.2	36.15	52.39	74	-21.61	Horizontal

Average value:

Frequency (MHz)	Read Level (dBuV)	Antenna Factor (dB/m)	Cable Loss (dB)	Preamplifier Factor (dB)	Level (dBuV/m)	Limit Line (dBuV/m)	Over Limit (dB)	Polarization
4804	36.8	31.28	5.66	35.29	38.45	54	-15.55	Vertical
7206	31	36.22	6.87	35.15	38.94	54	-15.06	Vertical
9608	27.53	37.85	8.8	35.55	38.63	54	-15.37	Vertical
12010	28.47	38.25	8.9	35.84	39.78	54	-14.22	Vertical
14412	27.24	39.25	9.2	36.15	39.54	54	-14.46	Vertical
4804	37.07	31.28	5.66	35.29	38.72	54	-15.28	Horizontal
7206	30.54	36.22	6.87	35.15	38.48	54	-15.52	Horizontal
9608	27.55	37.85	8.8	35.55	38.65	54	-15.35	Horizontal
12010	28.43	38.25	8.9	35.84	39.74	54	-14.26	Horizontal
14412	27.28	39.25	9.2	36.15	39.58	54	-14.42	Horizontal

Remark:

1. *Final Level = Receiver Read level + Antenna Factor + Cable Loss – Preamplifier Factor*
2. *“*”, means this data is the too weak instrument of signal is unable to test.*
3. *The emission levels of other frequencies are very lower than the limit and not show in test report.*

Test channel:	40
---------------	----

Peak value:

Frequency (MHz)	Read Level (dBuV)	Antenna Factor (dB/m)	Cable Loss (dB)	Preamp Factor (dB)	Level (dBuV/m)	Limit Line (dBuV/m)	Over Limit (dB)	Polarization
4882	43.94	30.88	5.7	35.27	45.25	74	-28.75	Vertical
7323	40.08	35.82	6.91	35.13	47.68	74	-26.32	Vertical
9764	38.58	37.45	8.84	35.53	49.34	74	-24.66	Vertical
12205	38.91	38.78	8.95	35.95	50.69	74	-23.31	Vertical
14412	38.61	39.64	9.27	36.74	50.78	74	-23.22	Vertical
4882	43.37	30.88	5.7	35.27	44.68	74	-29.32	Horizontal
7323	39.94	35.82	6.91	35.13	47.54	74	-26.46	Horizontal
9764	39.07	37.45	8.84	35.53	49.83	74	-24.17	Horizontal
12205	39.47	38.78	8.95	35.95	51.25	74	-22.75	Horizontal
14412	39.57	39.64	9.27	36.74	51.74	74	-22.26	Horizontal

Average value:

Frequency (MHz)	Read Level (dBuV)	Antenna Factor (dB/m)	Cable Loss (dB)	Preamp Factor (dB)	Level (dBuV/m)	Limit Line (dBuV/m)	Over Limit (dB)	Polarization
4882	36.94	30.88	5.7	35.27	38.25	54	-15.75	Vertical
7323	31.07	35.82	6.91	35.13	38.67	54	-15.33	Vertical
9764	27.71	37.45	8.84	35.53	38.47	54	-15.53	Vertical
12205	27.75	38.78	8.95	35.95	39.53	54	-14.47	Vertical
14412	27.46	39.64	9.27	36.74	39.63	54	-14.37	Vertical
4882	36.94	30.88	5.7	35.27	38.25	54	-15.75	Horizontal
7323	30.86	35.82	6.91	35.13	38.46	54	-15.54	Horizontal
9764	27.76	37.45	8.84	35.53	38.52	54	-15.48	Horizontal
12205	27.69	38.78	8.95	35.95	39.47	54	-14.53	Horizontal
14412	27.47	39.64	9.27	36.74	39.64	54	-14.36	Horizontal

Remark:

1. Final Level = Receiver Read level + Antenna Factor + Cable Loss – Pre-amplifier Factor
2. “*”, means this data is the too weak instrument of signal is unable to test.
3. The emission levels of other frequencies are very lower than the limit and not show in test report.

Test channel:	79
---------------	----

Peak value:

Frequency (MHz)	Read Level (dBuV)	Antenna Factor (dB/m)	Cable Loss (dB)	Preamp Factor (dB)	Level (dBuV/m)	Limit Line (dBuV/m)	Over Limit (dB)	Polarization
4960	46.3	30.98	5.73	35.32	47.69	74	-26.31	Vertical
7440	39.9	35.92	6.94	35.18	47.58	74	-26.42	Vertical
9920	41.32	37.55	8.87	35.58	52.16	74	-21.84	Vertical
12400	39.55	38.95	8.98	36.05	51.43	74	-22.57	Vertical
14880	38.36	39.87	9.34	36.88	50.69	74	-23.31	Vertical
4960	45.86	30.98	5.73	35.32	47.25	74	-26.75	Horizontal
7440	39.19	35.92	6.94	35.18	46.87	74	-27.13	Horizontal
9920	36.7	37.55	8.87	35.58	47.54	74	-26.46	Horizontal
12400	37.8	38.95	8.98	36.05	49.68	74	-24.32	Horizontal
14880	38.92	39.87	9.34	36.88	51.25	74	-22.75	Horizontal

Average value:

Frequency (MHz)	Read Level (dBuV)	Antenna Factor (dB/m)	Cable Loss (dB)	Preamp Factor (dB)	Level (dBuV/m)	Limit Line (dBuV/m)	Over Limit (dB)	Polarization
4960	38.15	30.98	5.73	35.32	39.54	54	-14.46	Vertical
7440	30.95	35.92	6.94	35.18	38.63	54	-15.37	Vertical
9920	29.28	37.55	8.87	35.58	40.12	54	-13.88	Vertical
12400	27.64	38.95	8.98	36.05	39.52	54	-14.48	Vertical
14880	27.35	39.87	9.34	36.88	39.68	54	-14.32	Vertical
4960	38.09	30.98	5.73	35.32	39.48	54	-14.52	Horizontal
7440	31.07	35.92	6.94	35.18	38.75	54	-15.25	Horizontal
9920	28.61	37.55	8.87	35.58	39.45	54	-14.55	Horizontal
12400	28.33	38.95	8.98	36.05	40.21	54	-13.79	Horizontal
14880	27.54	39.87	9.34	36.88	39.87	54	-14.13	Horizontal

Remark:

1. Final Level = Receiver Read level + Antenna Factor + Cable Loss – Pre-amplifier Factor
2. “*”, means this data is the too weak instrument of signal is unable to test.
3. The emission levels of other frequencies are very lower than the limit and not show in test report.

5. Test Setup Photos of the EUT

Radiated Emission (30MHz-1GHz)

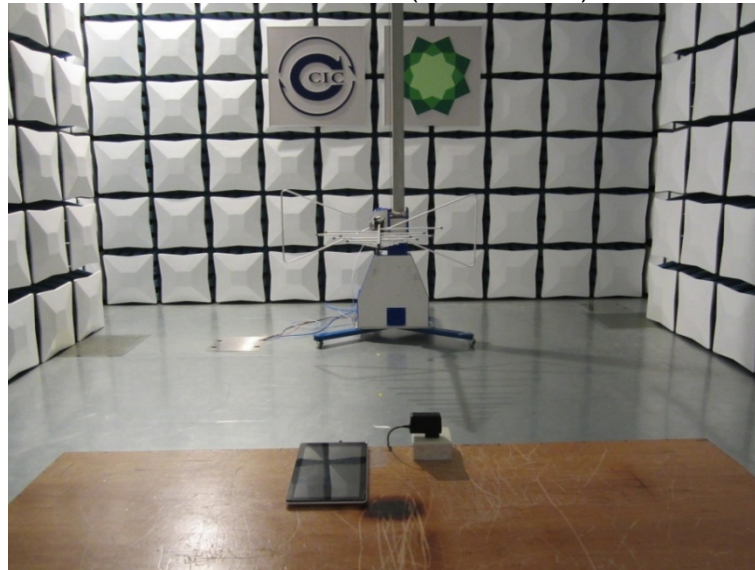

Radiated Emission (above 1GHz)



Conducted Emission (AC Mains)



6. External and Internal Photos of the EUT

Reference to the test report No. TRE1408006501

.....End of Report.....