



# MEASUREMENT REPORT

## FCC PART 15.247 WLAN 802.11b/g/n & BLE

---

**FCC ID:** 2AAP6E7232

**APPLICANT:** SHENZHEN ZOWEE TECHNOLOGY CO., LTD

**Application Type:** Certification

**Product:** Tablet PC

**Model No.:** E7232

**Brand Name:** MEDION

**FCC Classification:** Digital Transmission System (DTS)

**FCC Rule Part(s):** Part 15.247

**Test Procedure(s):** ANSI C63.10-2009, KDB 558074 D01v03r02

**Test Date:** Oct. 20 ~ 24, 2014

Reviewed By : Robin Wu  
( Robin Wu )

Approved By : Marlin Chen  
( Marlin Chen )

The test results relate only to the samples tested.

This equipment has been shown to be capable of compliance with the applicable technical standards as indicated in the measurement report and was tested in accordance with the measurement procedures specified in KDB 558074 D01v03r02. Test results reported herein relate only to the item(s) tested.

The test report shall not be reproduced except in full without the written approval of MRT Technology (Suzhou) Co., Ltd.

### Revision History

Report No.	Version	Description	Issue Date
1410RSU01001	Rev. 01	Initial report	10-27-2014

## CONTENTS

Description	Page
<b>1. INTRODUCTION .....</b>	<b>6</b>
1.1. Scope .....	6
1.2. MRT Test Location .....	6
<b>2. PRODUCT INFORMATION .....</b>	<b>7</b>
2.1. Equipment Description.....	7
2.2. Device Capabilities .....	9
2.3. Test Configuration .....	9
2.4. EMI Suppression Device(s)/Modifications.....	9
2.5. Labeling Requirements.....	9
2.6. Test Software .....	9
<b>3. DESCRIPTION OF TEST .....</b>	<b>10</b>
3.1. Evaluation Procedure .....	10
3.2. AC Line Conducted Emissions .....	10
3.3. Radiated Emissions .....	11
<b>4. ANTENNA REQUIREMENTS.....</b>	<b>12</b>
<b>5. TEST EQUIPMENT CALIBRATION DATE.....</b>	<b>13</b>
<b>6. MEASUREMENT UNCERTAINTY.....</b>	<b>14</b>
<b>7. TEST RESULT .....</b>	<b>15</b>
7.1. Summary .....	15
7.2. 6dB Bandwidth Measurement.....	16
7.2.1. Test Limit .....	16
7.2.2. Test Procedure used.....	16
7.2.3. Test Setting.....	16
7.2.4. Test Setup.....	16
7.2.5. Test Result.....	17
7.3. Output Power Measurement.....	21
7.3.1. Test Limit .....	21
7.3.2. Test Procedure Used .....	21
7.3.3. Test Setting.....	21
7.3.4. Test Setup.....	21
7.3.5. Test Result of Output Power .....	22
7.4. Power Spectral Density Measurement.....	24
7.4.1. Test Limit .....	24

---

7.4.2.	Test Procedure Used .....	24
7.4.3.	Test Setting.....	24
7.4.4.	Test Setup.....	24
7.4.5.	Test Result.....	25
7.5.	Conducted Band Edge and Out-of-Band Emissions.....	29
7.5.1.	Test Limit .....	29
7.5.2.	Test Procedure Used .....	29
7.5.3.	Test Setting.....	29
7.5.4.	Test Setup.....	30
7.5.5.	Test Result.....	31
7.6.	Radiated Spurious Emission Measurement .....	39
7.6.1.	Test Limit .....	39
7.6.2.	Test Procedure Used .....	39
7.6.3.	Test Setting.....	39
7.6.4.	Test Setup.....	41
7.6.5.	Test Result.....	43
7.7.	Radiated Restricted Band Edge Measurement .....	51
7.7.1.	Test Result.....	51
7.8.	AC Conducted Emissions Measurement.....	67
7.8.1.	Test Limit .....	67
7.8.2.	Test Setup.....	67
7.8.3.	Test Result.....	68
<b>8.</b>	<b>CONCLUSION.....</b>	<b>70</b>

## §2.1033 General Information

<b>Applicant:</b>	SHENZHEN ZOWEE TECHNOLOGY CO., LTD
<b>Applicant Address:</b>	Science & Technology Industrial Park of Privately Owned Enterprises, Pingshan, Xili, Nanshan District, Shenzhen, P.R. CHINA
<b>Manufacturer:</b>	SHENZHEN ZOWEE TECHNOLOGY CO., LTD
<b>Manufacturer Address:</b>	Science & Technology Industrial Park of Privately Owned Enterprises, Pingshan, Xili, Nanshan District, Shenzhen, P.R. CHINA
<b>Test Site:</b>	MRT Technology (Suzhou) Co., Ltd
<b>Test Site Address:</b>	D8 Building, Youxin Industrial Park, No.2 Tian'edang Rd., Wuzhong Economic Development Zone, Suzhou, China
<b>MRT Registration No.:</b>	809388
<b>FCC Rule Part(s):</b>	Part 15.247
<b>Model No.:</b>	E7232
<b>FCC ID:</b>	2AAP6E7232
<b>Test Device Serial No.:</b>	N/A <input type="checkbox"/> Production <input checked="" type="checkbox"/> Pre-Production <input type="checkbox"/> Engineering
<b>FCC Classification:</b>	Digital Transmission System (DTS)
<b>Date(s) of Test:</b>	Oct. 20 ~ 24, 2014
<b>Test Report S/N:</b>	1410RSU01001

### Test Facility / Accreditations

Measurements were performed at MRT Laboratory located in Tian'edang Rd., Suzhou, China.

- MRT Lab is accredited to ISO 17025 by the American Association for Laboratory Accreditation (A2LA) under the American Association for Laboratory Accreditation Program (A2LA Cert. No. 3628.01) in EMC, Telecommunications and Radio testing for FCC, Industry Canada, EU and TELEC Rules.
- MRT facility is a FCC registered (MRT Reg. No. 809388) test facility with the site description report on file and has met all the requirements specified in Section 2.948 of the FCC Rules and Industry Canada (11384A-1).
- MRT facility is an IC registered (11384A-1) test laboratory with the site description on file at Industry Canada.

# 1. INTRODUCTION

## 1.1. Scope

Measurement and determination of electromagnetic emissions (EMC) of radio frequency devices including intentional and/or unintentional radiators for compliance with the technical rules and regulations of the Federal Communications Commission and the Industry Canada Certification and Engineering Bureau.

## 1.2. MRT Test Location

The map below shows the location of the MRT LABORATORY, its proximity to the Taihu Lake. These measurement tests were conducted at the MRT Technology (Suzhou) Co., Ltd. Facility located at D8 Building, Youxin Industrial Park, No.2 Tian'edang Rd., Wuzhong Economic Development Zone, Suzhou, China. The detailed description of the measurement facility was found to be in compliance with the requirements of § 2.948 according to ANSI C63.4-2009 on September 30, 2013.



## 2. PRODUCT INFORMATION

### 2.1. Equipment Description

Product Name	Tablet PC
Model No.	E7232
<b>Wi-Fi</b>	
Frequency Range	802.11b/g/n-HT20: 2412 ~ 2462 MHz
Type of Modulation	802.11b: DSSS 802.11g/n: OFDM
Data Rate	802.11b: 1/2/5.5/11 Mbps 802.11g: 6/9/12/18/24/36/48/54 Mbps 802.11n: up to 72.2 Mbps
Maximum Output Power	802.11b: 17.43dBm 802.11g: 22.68dBm 802.11n-HT20: 21.65dBm BLE: 4.89dBm
Antenna Type	Internal
Antenna Gain	0.8dBi
<b>Bluetooth</b>	
Bluetooth Frequency	2402~2480MHz
Bluetooth Version	V4.0
Type of modulation	FHSS
Data Rate	1Mbps(GFSK)
Antenna Gain	0.8dBi

**Channel List for 802.11b/g/n-HT20**

Channel	Frequency	Channel	Frequency	Channel	Frequency
01	2412 MHz	02	2417 MHz	03	2422 MHz
04	2427 MHz	05	2432 MHz	06	2437 MHz
07	2442 MHz	08	2447 MHz	09	2452 MHz
10	2457 MHz	11	2462 MHz	N/A	N/A

**Channel List for BLE**

Channel	Frequency	Channel	Frequency	Channel	Frequency
00	2402 MHz	01	2404 MHz	02	2406 MHz
03	2408 MHz	04	2410 MHz	05	2412 MHz
06	2414 MHz	07	2416 MHz	08	2418 MHz
09	2420 MHz	10	2422 MHz	11	2424 MHz
12	2426 MHz	13	2428 MHz	14	2430 MHz
15	2432 MHz	16	2434 MHz	17	2436 MHz
18	2438 MHz	19	2440 MHz	20	2442 MHz
21	2444 MHz	22	2446 MHz	23	2448 MHz
24	2450 MHz	25	2452 MHz	26	2454 MHz
27	2456 MHz	28	2458 MHz	29	2460 MHz
30	2462 MHz	31	2464 MHz	32	2466 MHz
33	2468 MHz	34	2470 MHz	35	2472 MHz
36	2474 MHz	37	2476 MHz	38	2478 MHz
39	2480 MHz	N/A	N/A	N/A	N/A



## 2.2. Device Capabilities

This device contains the following capabilities:

802.11b/g/n WLAN (DTS) & BLE

**Note:** 2.4GHz WLAN (DTS) operation is possible in 20MHz, and 40MHz channel bandwidths. The maximum achievable duty cycles for all modes were determined based on measurements performed on a spectrum analyzer in zero-span mode with RBW = 8MHz, VBW = 50MHz, and detector = peak per the guidance of Section 6.0 b) of KDB 558074 D01v03r02. The RBW and VBW were both greater than  $50/T$ , where T is the minimum transmission duration, and the number of sweep points across T was greater than 100. The duty cycles are as follows:

- 802.11b - 100.0%
- 802.11g/n-HT20 -100.0%
- 802.11n-HT40 -100.0%
- 

## 2.3. Test Configuration

The **Tablet PC FCC ID: 2AAP6E7232** was tested per the guidance of KDB 558074 D01v03r02. ANSI C63.10-2009 was used to reference the appropriate EUT setup for radiated spurious emissions testing and AC line conducted testing.

## 2.4. EMI Suppression Device(s)/Modifications

No EMI suppression device(s) were added and/or no modifications were made during testing.

## 2.5. Labeling Requirements

Per 2.1074 & 15.19; Docket 95-19

The label shall be permanently affixed at a conspicuous location on the device; instruction manual or pamphlet supplied to the user and be readily visible to the purchaser at the time of purchase.

However, when the device is so small wherein placement of the label with specified statement is not practical, only the trade name and FCC ID must be displayed on the device per Section 15.19(a)(5). Please see attachment for FCC ID label and label location.

## 2.6. Test Software

The test utility software used during testing was engineering order by applicant.

### 3. DESCRIPTION OF TEST

#### 3.1. Evaluation Procedure

The measurement procedures described in the American National Standard for Testing Unlicensed Wireless Devices (ANSI C63.10-2009), and the guidance provided in KDB 558074 D01v03r02 were used in the measurement of the **Tablet PC FCC ID: 2AAP6E7232**.

**Deviation from measurement procedure.....None**

#### 3.2. AC Line Conducted Emissions

The line-conducted facility is located inside an 8'x4'x4' shielded enclosure. A 1m x 2m wooden table 80cm high is placed 40cm away from the vertical wall and 80cm away from the sidewall of the shielded room. Two 10kHz-30MHz, 50Ω/50uH Line-Impedance Stabilization Networks (LISNs) are bonded to the shielded room floor. Power to the LISNs is filtered by external high-current high-insertion loss power line filters. These filters attenuate ambient signal noise from entering the measurement lines. These filters are also bonded to the shielded enclosure.

The EUT is powered from one LISN and the support equipment is powered from the second LISN. All interconnecting cables more than 1 meter were shortened to a 1 meter length by non-inductive bundling (serpentine fashion) and draped over the back edge of the test table. All cables were at least 40cm above the horizontal reference ground-plane. Power cables for support equipment were routed down to the second LISN while ensuring that that cables were not draped over the second LISN.

Sufficient time for the EUT, support equipment, and test equipment was allowed in order for them to warm up to their normal operating condition. The RF output of the LISN was connected to the receiver and exploratory measurements were made to determine the frequencies producing the maximum emission from the EUT. The receiver was scanned from 150kHz to 30MHz. The detector function was set to peak mode for exploratory measurements while the bandwidth of the analyzer was set to 9kHz. The EUT, support equipment, and interconnecting cables were arranged and manipulated to maximize each emission. Each emission was also maximized by varying: power lines, the mode of operation or data exchange speed, or support equipment whichever determined the worst-case emission. Once the worst case emissions have been identified, the one EUT cable configuration/arrangement and mode of operation that produced these emissions were used for final measurements on the same test site. The analyzer is set to CISPR quasi-peak and average detectors with a 9kHz resolution bandwidth for final measurements.

An extension cord was used to connect to a single LISN which powered by EUT. The extension cord was calibrated with LISN, the impedance and insertion loss are compliance with the requirements as stated in ANSI C63.10-2009 at Clause 4.3.

Line conducted emissions test results are shown in Section 7.8.

### 3.3. Radiated Emissions

The radiated test facilities consisted of an indoor 3 meter semi-anechoic chamber used for final measurements and exploratory measurements, when necessary. The measurement area is contained within the semi-anechoic chamber which is shielded from any ambient interference. For measurements above 1GHz absorbers are arranged on the floor between the turn table and the antenna mast in such a way so as to maximize the reduction of reflections. For measurements below 1GHz, the absorbers are removed. A MF Model 210SS turntable is used for radiated measurement. It is a continuously rotatable, remote controlled, metallic turntable and 2 meters (6.56 ft.) in diameter. The turn table is flush with the raised floor of the chamber in order to maintain its function as a ground plane. An 80cm high PVC support structure is placed on top of the turntable.

For all measurements, the spectrum was scanned through all EUT azimuths and from 1 to 4 meter receive antenna height using a broadband antenna from 30MHz up to the upper frequency shown in 15.33(b)(1) depending on the highest frequency generated or used in the device or on which the device operates or tunes. For frequencies above 1GHz, linearly polarized double ridge horn antennas were used. For frequencies below 30MHz, a calibrated loop antenna was used. When exploratory measurements were necessary, they were performed at 1 meter test distance inside the semi-anechoic chamber using broadband antennas, broadband amplifiers, and spectrum analyzers to determine the frequencies and modes producing the maximum emissions. Sufficient time for the EUT, support equipment, and test equipment was allowed in order for them to warm up to their normal operating condition. The test set-up was placed on top of the 0.8 meter high, 1 x 1.5 meter table. The EUT, support equipment, and interconnecting cables were arranged and manipulated to maximize each emission. Appropriate precaution was taken to ensure that all emissions from the EUT were maximized and investigated. The system configuration, clock speed, mode of operation or video resolution, if applicable, turntable azimuth, and receive antenna height was noted for each frequency found.

Final measurements were made in the semi-anechoic chamber using calibrated, linearly polarized broadband and horn antennas. The test setup was configured to the setup that produced the worst case emissions. The spectrum analyzer was set to investigate all frequencies required for testing to compare the highest radiated disturbances with respect to the specified limits. The turntable containing the EUT was rotated through 360 degrees and the height of the receive antenna was varied 1 to 4 meters and stopped at the azimuth and height producing the maximum emission. Each emission was maximized by changing the orientation of the EUT through three orthogonal planes and changing the polarity of the receive antenna, whichever produced the worst-case emissions. According to 3dB BeamWidth of horn antenna, the horn antenna should be always directed to the EUT when rising height.

#### 4. ANTENNA REQUIREMENTS

**Excerpt from §15.203 of the FCC Rules/Regulations:**

“An intentional radiator antenna shall be designed to ensure that no antenna other than that furnished by the responsible party can be used with the device. The use of a permanently attached antenna or of an antenna that uses a unique coupling to the intentional radiator shall be considered sufficient to comply with the provisions of this section.”

- The antenna of the Tablet PC is **permanently attached**.
- There are no provisions for connection to an external antenna.

**Conclusion:**

The **Tablet PC FCC ID: 2AAP6E7232** unit complies with the requirement of §15.203.

## 5. TEST EQUIPMENT CALIBRATION DATE

### Conducted Emissions

Instrument	Manufacturer	Type No.	Serial No.	Cali. Interval	Cali. Due Date
EMI Test Receiver	R&S	ESR7	101209	1 year	2014/11/08
Two-Line V-Network	R&S	ENV216	101683	1 year	2014/11/08
Two-Line V-Network	R&S	ENV216	101684	1 year	2014/11/08
Temperature/ Meter Humidity	Anymetre	TH101B	SR2-01	1 year	2014/11/15

### Radiated Emission

Instrument	Manufacturer	Type No.	Serial No.	Cali. Interval	Cali. Due Date
Spectrum Analyzer	Agilent	N9010A	MY5144016A	1 year	2015/01/04
Preamplifier	MRT	AP01G18	1310002	1 year	2015/10/06
Loop Antenna	Schwarzbeck	FMZB1519	1519-041	1 year	2014/11/24
TRILOG Antenna	Schwarzbeck	VULB9162	9162-047	1 year	2014/11/24
Broad-Band Horn Antenna	Schwarzbeck	BBHA9120D	9120D-1167	1 year	2014/11/24
Broadband Horn Antenna	Schwarzbeck	BBHA9170	9170-549	1 year	2014/12/11
Temperature/Humidity Meter	Anymetre	TH101B	AC1-01	1 year	2014/11/15

### Conducted Test Equipment

Instrument	Manufacturer	Type No.	Serial No.	Cali. Interval	Cali. Due Date
Spectrum Analyzer	Agilent	N9010A	MY5144016A	1 year	2015/01/04
Power Sensor	Agilent	U2021XA	MY52450003	1 year	2014/12/14
Temperature/Humidity Meter	Anymetre	TH101B	TR3-01	1 year	2014/11/15

## 6. MEASUREMENT UNCERTAINTY

Where relevant, the following test uncertainty levels have been estimated for tests performed on the EUT as specified in CISPR 16-4-2. This uncertainty represents an expanded uncertainty expressed at approximately the 95% confidence level using a coverage factor of  $k = 2$ .

<b>AC Conducted Emission Measurement</b>
Measuring Uncertainty for a Level of Confidence of 95% ( $U=2Uc(y)$ ): 150kHz~30MHz: $\pm 3.46\text{dB}$
<b>Radiated Emission Measurement</b>
Measuring Uncertainty for a Level of Confidence of 95% ( $U=2Uc(y)$ ): 9kHz ~ 1GHz: $\pm 4.18\text{dB}$ 1GHz ~ 25GHz: $\pm 4.76\text{dB}$

## 7. TEST RESULT

### 7.1. Summary

**Company Name:** SHENZHEN ZOWEE TECHNOLOGY CO.,LTD  
**FCC ID:** 2AAP6E7232  
**FCC Classification:** Digital Transmission System (DTS)  
**Data Rate(s)** 1Mbps ~ 11Mbps (b); 6Mbps ~ 54Mbps (g);  
**Tested:** 6.5/7.2Mbps ~ 65/72.2Mbps (n-HT20); 1Mbps (BLE);

FCC Part Section(s)	Test Description	Test Limit	Test Condition	Test Result	Reference
15.247(a)(2)	6dB Bandwidth	$\geq 500\text{kHz}$	Conducted	Pass	Section 7.2
15.247(b)(3)	Output Power	$\leq 1\text{Watt}$		Pass	Section 7.3
15.247(e)	Power Spectral Density	$\leq 8\text{dBm} / 3\text{kHz Band}$		Pass	Section 7.4
15.247(d)	Band Edge / Out-of-Band Emissions	$\geq 20\text{dBc(Peak)}$		Pass	Section 7.5
15.205 15.209	General Field Strength Limits (Restricted Bands and Radiated Emission Limits)	Emissions in restricted bands must meet the radiated limits detailed in 15.209	Radiated	Pass	Section 7.6 & 7.7
15.207	AC Conducted Emissions 150kHz - 30MHz	< FCC 15.207 limits	Line Conducted	Pass	Section 7.8

#### Notes:

- 1) All modes of operation and data rates were investigated. For radiated emission test, every axis (X, Y, Z) was also verified. The test results shown in the following sections represent the worst case emissions.
- 2) The analyzer plots shown in this section were all taken with a correction table loaded into the analyzer. The correction table was used to account for the losses of the cables and attenuators used as part of the system to connect the EUT to the analyzer at all frequencies of interest.
- 3) All antenna port conducted emissions testing was performed on a test bench with the antenna port of the EUT connected to the spectrum analyzer through calibrated cables and attenuators.

## 7.2. 6dB Bandwidth Measurement

### 7.2.1. Test Limit

The minimum 6dB bandwidth shall be at least 500 kHz.

### 7.2.2. Test Procedure used

KDB 558074 D01v03r02 - Section 8.2 Option 2

### 7.2.3. Test Setting

1. The Spectrum's automatic bandwidth measurement capability was used to perform the 6dB bandwidth measurement. The "X" dB bandwidth parameter was set to  $X = 6$ . The bandwidth measurement was not influenced by any intermediate power nulls in the fundamental emission.
2. Set RBW = 100 kHz
3. VBW  $\geq 3 \times$  RBW
4. Detector = Peak
5. Trace mode = max hold
6. Sweep = auto couple
7. Allow the trace was allowed to stabilize

### 7.2.4. Test Setup

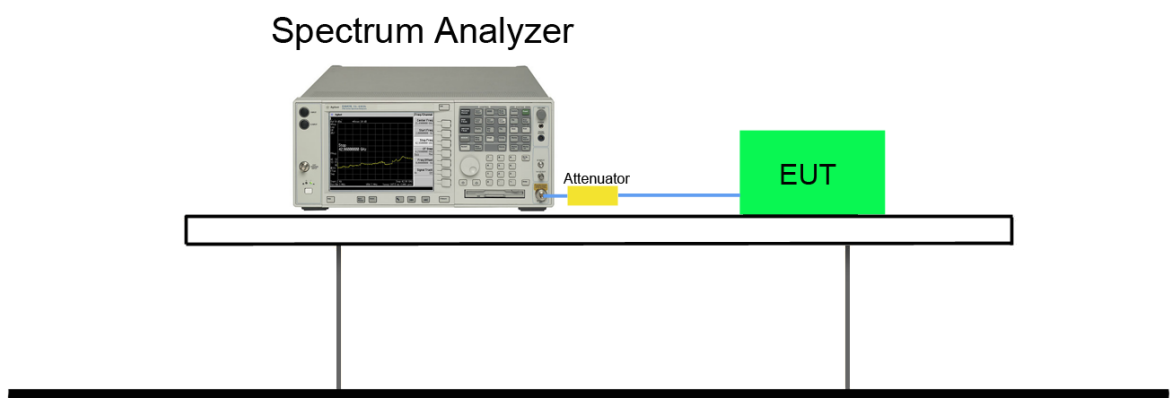



### 7.2.5. Test Result

Test Mode	Data Rate (Mbps)	Channel No.	Frequency (MHz)	6dB Bandwidth (MHz)	Limit (MHz)	Result
802.11b	1	01	2412	8.08	≥ 0.5	Pass
802.11b	1	06	2437	8.05	≥ 0.5	Pass
802.11b	1	11	2462	8.07	≥ 0.5	Pass
802.11g	6	01	2412	15.14	≥ 0.5	Pass
802.11g	6	06	2437	15.34	≥ 0.5	Pass
802.11g	6	11	2462	15.34	≥ 0.5	Pass
802.11n-HT20	6.5	01	2412	15.14	≥ 0.5	Pass
802.11n-HT20	6.5	06	2437	15.14	≥ 0.5	Pass
802.11n-HT20	6.5	11	2462	15.15	≥ 0.5	Pass
BLE	1	00	2402	0.72	≥ 0.5	Pass
BLE	1	19	2440	0.72	≥ 0.5	Pass
BLE	1	39	2480	0.73	≥ 0.5	Pass

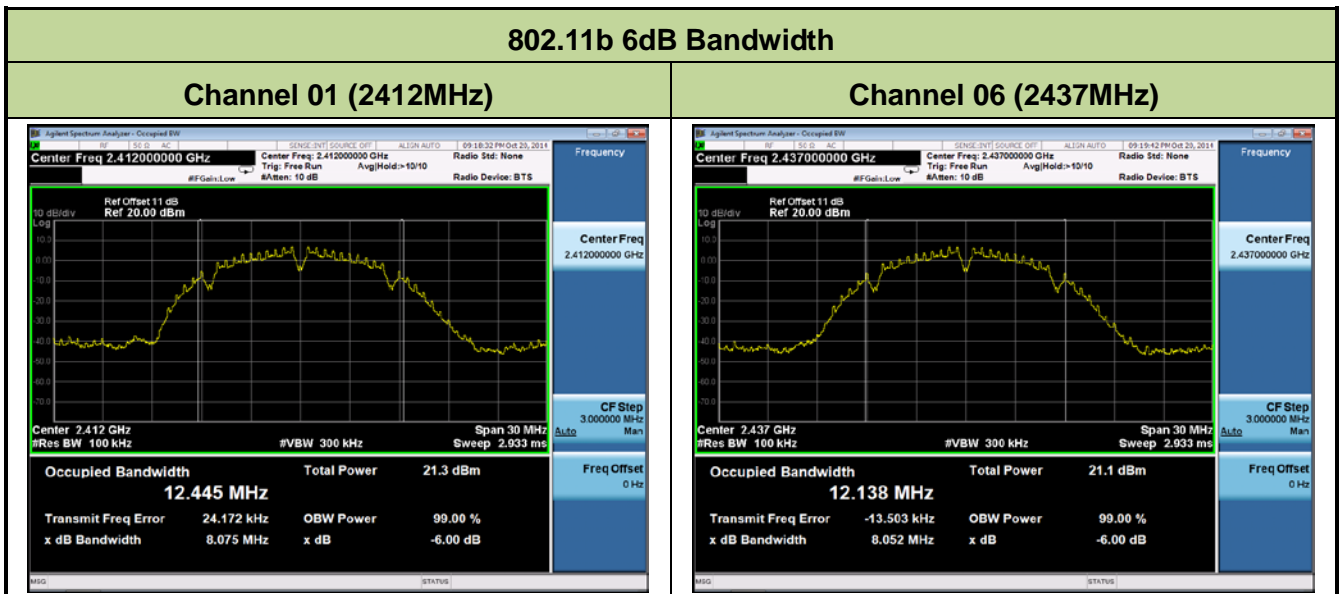

### Channel 11 (2462MHz)

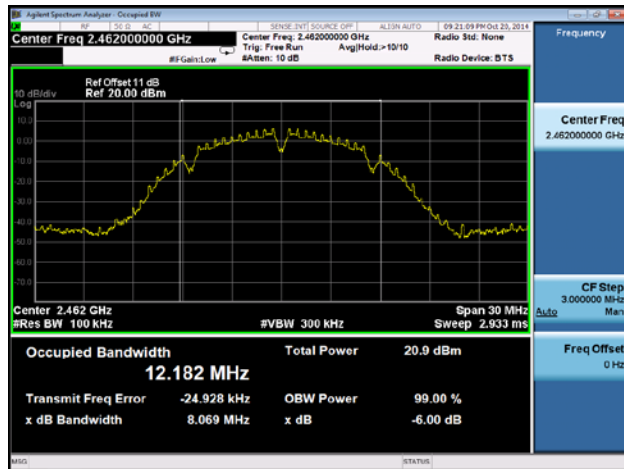

### 802.11g 6dB Bandwidth

### Channel 01 (2412MHz)

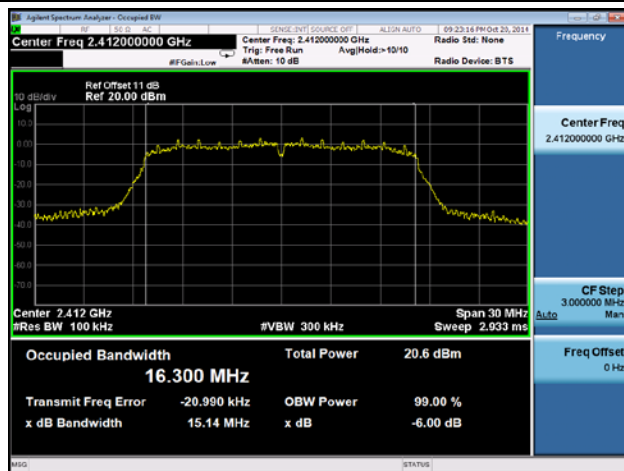

### Channel 06 (2437MHz)

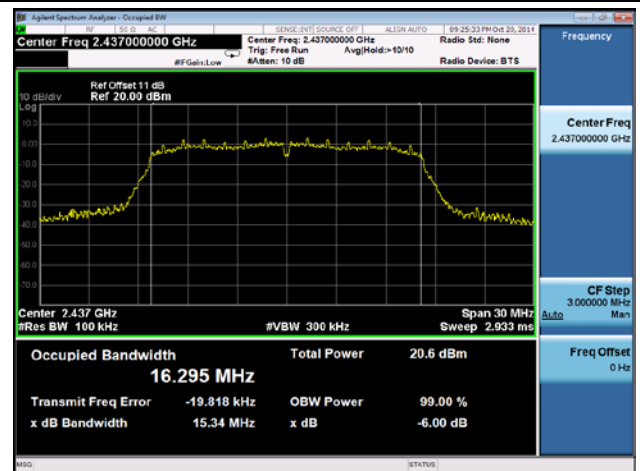

### Channel 11 (2462MHz)

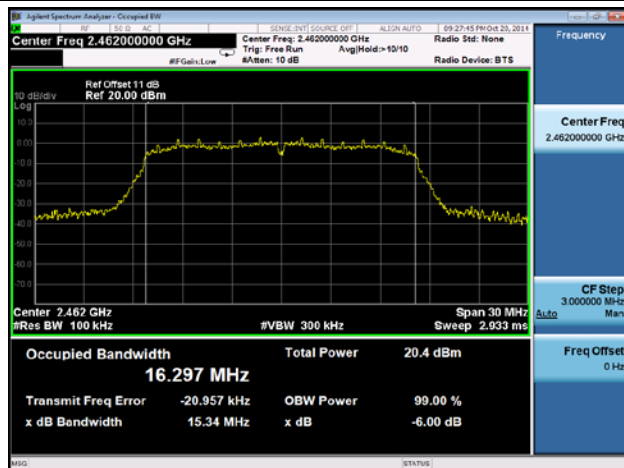

### 802.11n-HT20 6dB Bandwidth

#### Channel 01 (2412MHz)

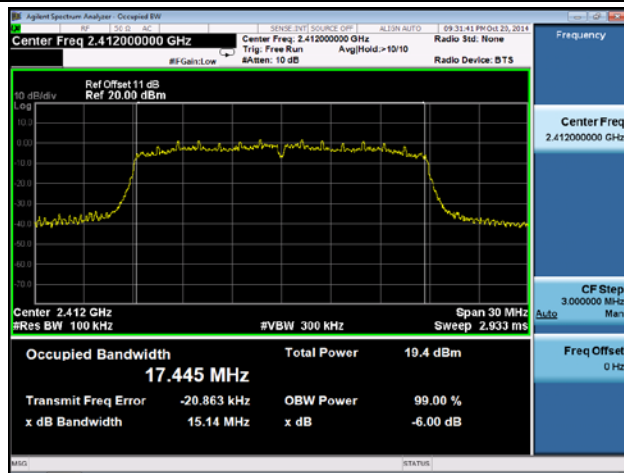

#### Channel 06 (2437MHz)

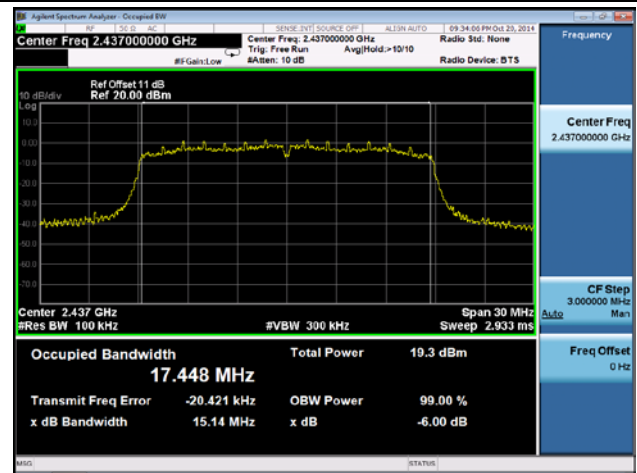

#### Channel 11 (2462MHz)

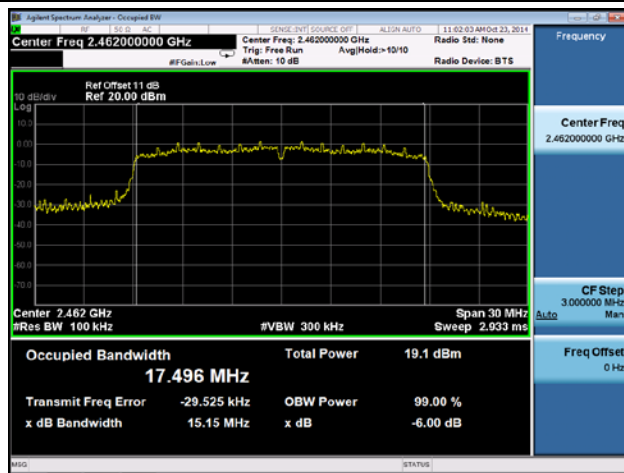

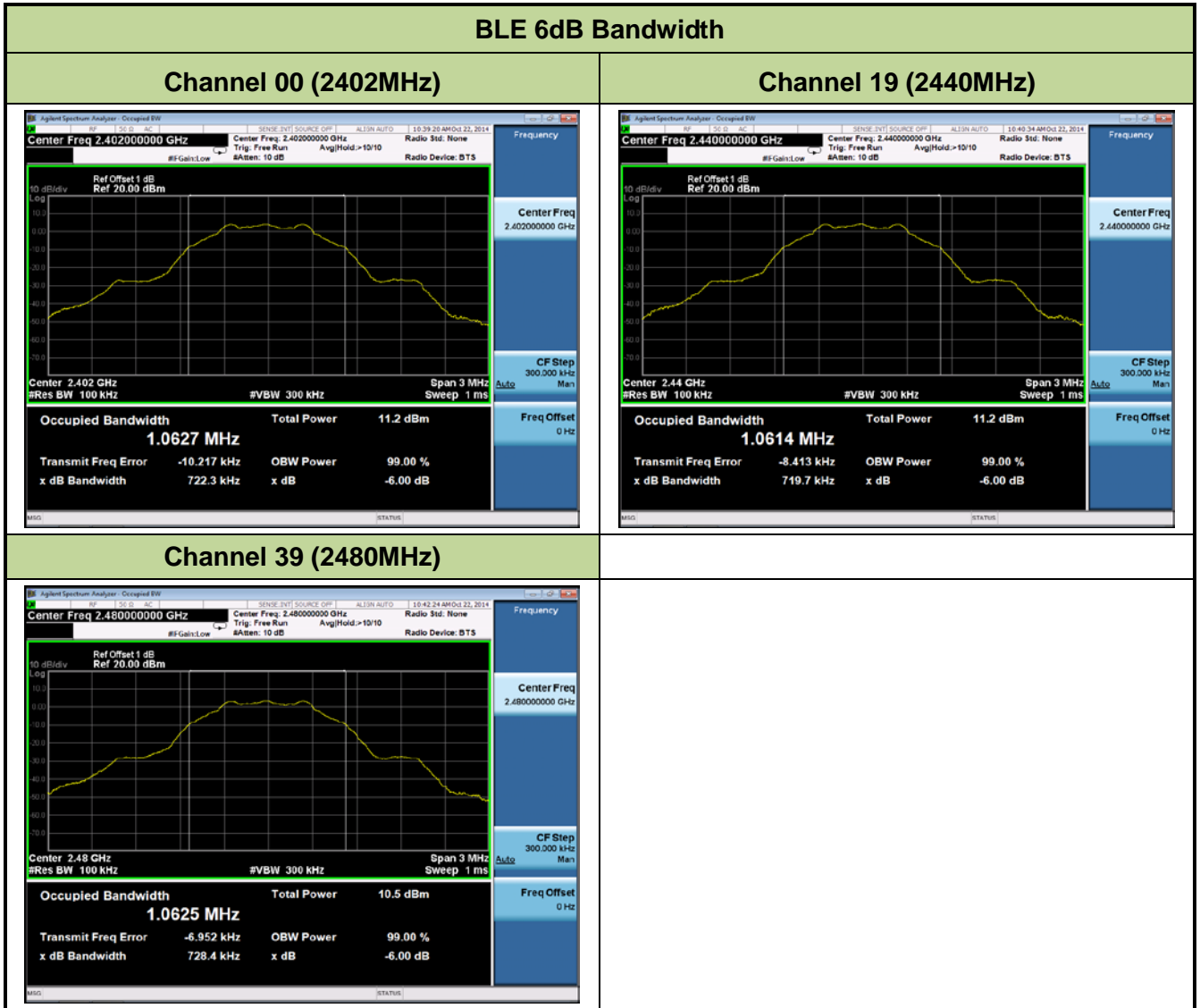

### 7.3. Output Power Measurement

#### 7.3.1. Test Limit

The maximum out power shall be less 1 Watt (30dBm).

#### 7.3.2. Test Procedure Used

KDB 558074 D01v03r02 - Section 9.1.2 PKPM1 Peak Power Method (for signals with BW  $\leq$  50MHz)

#### 7.3.3. Test Setting

##### **Method PKPM1 (Peak Power Measurement of Signals with DTS BW $\leq$ 50MHz)**

Peak power measurements were performed only when the EUT was transmitting at its maximum power control level using a broadband power meter with a pulse sensor. The pulse sensor employs a VBW = 50MHz so this method was only used for signals whose DTS bandwidth was less than or equal to 50MHz.

#### 7.3.4. Test Setup

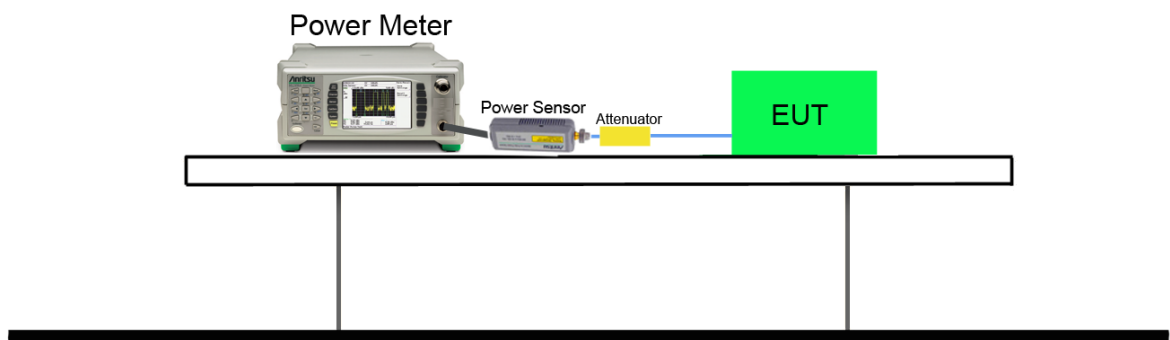

### 7.3.5. Test Result of Output Power

Output power at various data rates:

Test Mode	Bandwidth (MHz)	Channel No.	Frequency (MHz)	Data Rate (Mbps)	Peak Power (dBm)
802.11b	20	6	2437	1	17.23
				5.5	16.94
				11	16.52
802.11g	20	6	2437	6	22.68
				24	22.01
				54	21.78
802.11n	20	6	2437	6.5(MCS0)	21.44
				39(MCS4)	20.84
				65(MCS7)	20.31

**Test Result of Peak Output Power**

Test Mode	Data Rate (Mbps)	Channel No.	Frequency (MHz)	Peak Power (dBm)	Limit (dBm)	Result
11b	1	1	2412	17.43	≤ 30	Pass
11b	1	6	2437	17.23	≤ 30	Pass
11b	1	11	2462	17.17	≤ 30	Pass
11g	6	1	2412	22.29	≤ 30	Pass
11g	6	6	2437	22.68	≤ 30	Pass
11g	6	11	2462	22.58	≤ 30	Pass
11n-HT20	6.5	1	2412	21.65	≤ 30	Pass
11n-HT20	6.5	6	2437	21.44	≤ 30	Pass
11n-HT20	6.5	11	2462	21.37	≤ 30	Pass
BLE	1	00	2402	4.89	≤ 30	Pass
BLE	1	19	2440	4.09	≤ 30	Pass
BLE	1	39	2480	4.16	≤ 30	Pass

**Test Result of Average Output Power (Reporting Only)**

Test Mode	Data Rate (Mbps)	Channel No.	Frequency (MHz)	Average Power (dBm)	Limit (dBm)	Result
11b	1	1	2412	14.26	≤ 30	Pass
11b	1	6	2437	14.01	≤ 30	Pass
11b	1	11	2462	13.95	≤ 30	Pass
11g	6	1	2412	13.31	≤ 30	Pass
11g	6	6	2437	13.10	≤ 30	Pass
11g	6	11	2462	13.03	≤ 30	Pass
11n-HT20	6.5	1	2412	12.06	≤ 30	Pass
11n-HT20	6.5	6	2437	11.84	≤ 30	Pass
11n-HT20	6.5	11	2462	11.80	≤ 30	Pass
BLE	1	00	2402	2.57	≤ 30	Pass
BLE	1	19	2440	1.76	≤ 30	Pass
BLE	1	39	2480	1.81	≤ 30	Pass

## 7.4. Power Spectral Density Measurement

### 7.4.1. Test Limit

The maximum permissible power spectral density is 8dBm in any 3 kHz band.

### 7.4.2. Test Procedure Used

KDB 558074 D01v03r02 - Section 10.2 Method PKPSD

### 7.4.3. Test Setting

1. Analyzer was set to the center frequency of the DTS channel under investigation
2. Span = 1.5 times the DTS channel bandwidth
3. RBW = 3kHz
4. VBW = 10kHz
5. Detector = peak
6. Sweep time = auto couple
7. Trace mode = max hold
8. Trace was allowed to stabilize

### 7.4.4. Test Setup

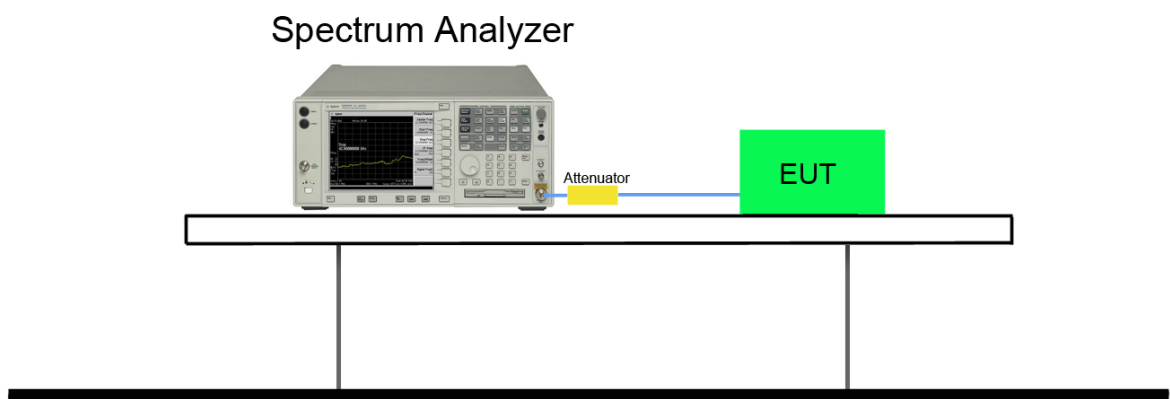



**7.4.5. Test Result**

Test Mode	Data Rate (Mbps)	Channel No.	Frequency (MHz)	PSD Result (dBm)	Limit (dBm / 3kHz)	Result
11b	1	1	2412	-5.071	≤ 8	Pass
11b	1	6	2437	-5.825	≤ 8	Pass
11b	1	11	2462	-5.408	≤ 8	Pass
11g	6	1	2412	-9.461	≤ 8	Pass
11g	6	6	2437	-9.481	≤ 8	Pass
11g	6	11	2462	-9.618	≤ 8	Pass
11n-HT20	6.5	1	2412	-9.805	≤ 8	Pass
11n-HT20	6.5	6	2437	-10.313	≤ 8	Pass
11n-HT20	6.5	11	2462	-10.08	≤ 8	Pass
BLE	1	00	2402	-9.111	≤ 8	Pass
BLE	1	19	2440	-9.082	≤ 8	Pass
BLE	1	39	2480	-9.001	≤ 8	Pass

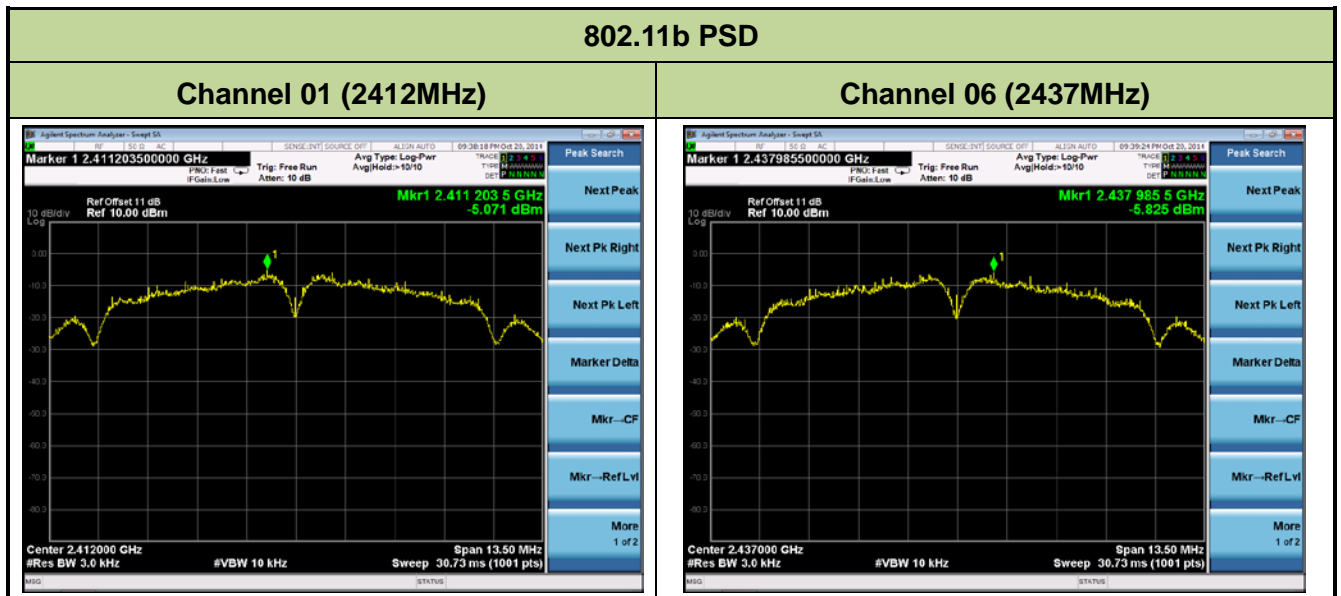

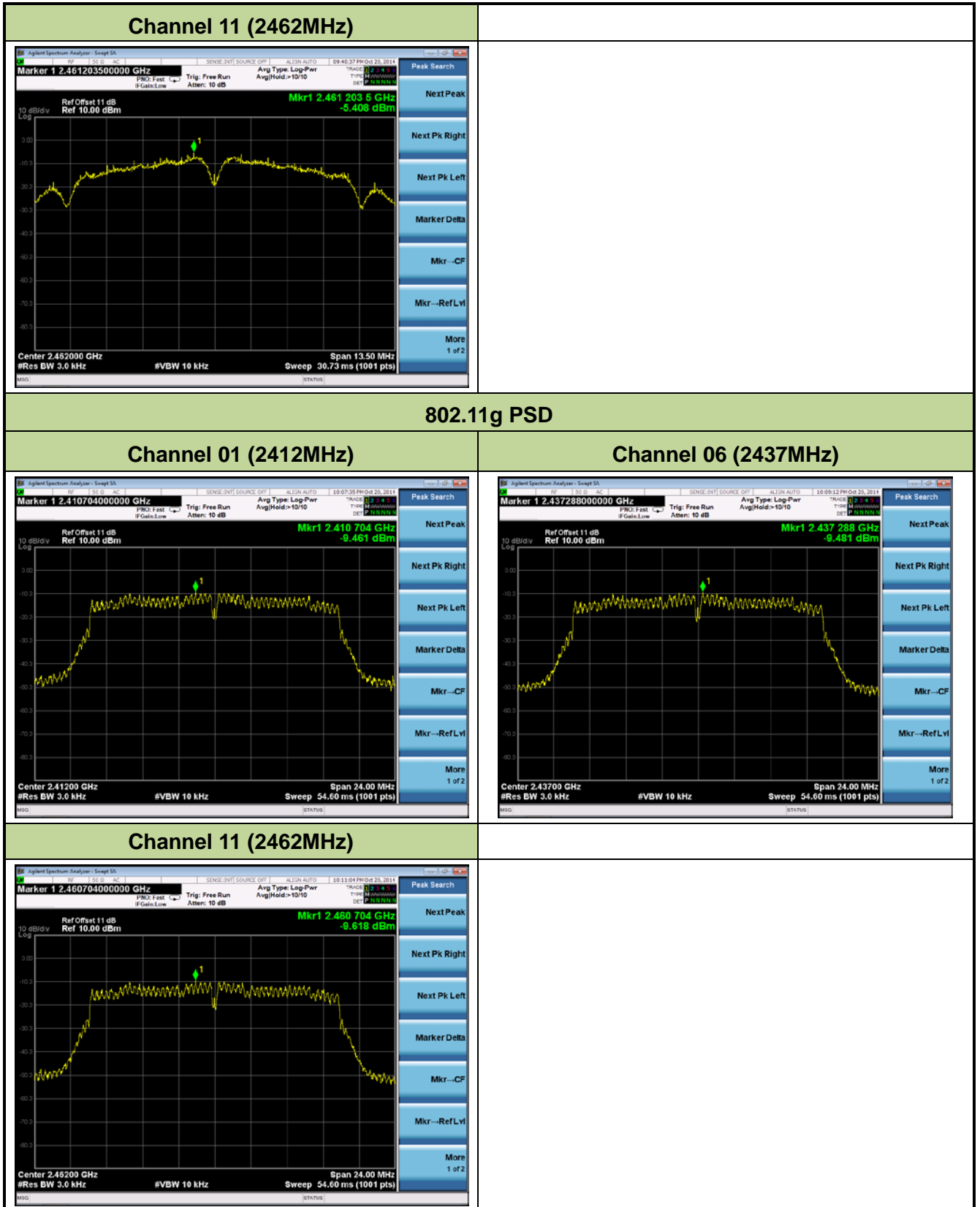

### 802.11n-HT20 PSD

#### Channel 01 (2412MHz)

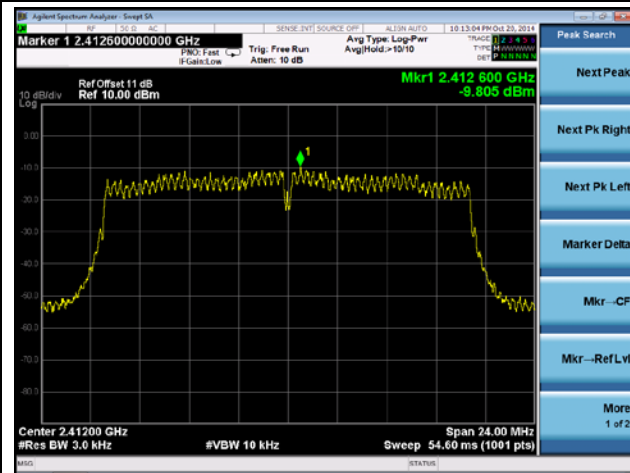

#### Channel 06 (2437MHz)

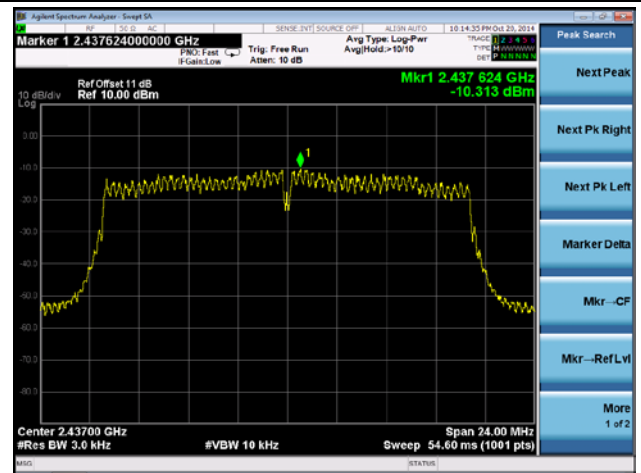

#### Channel 11 (2462MHz)

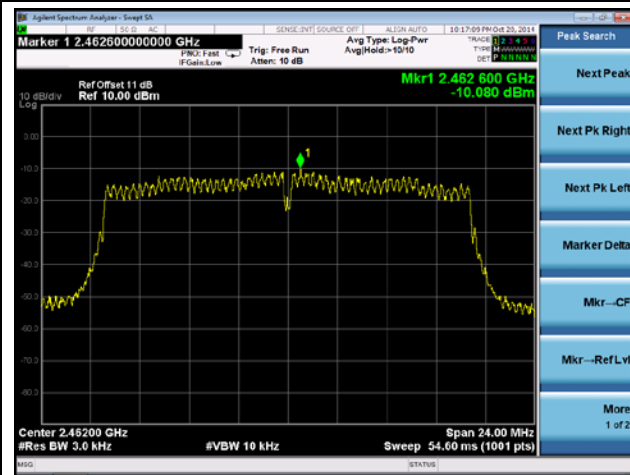

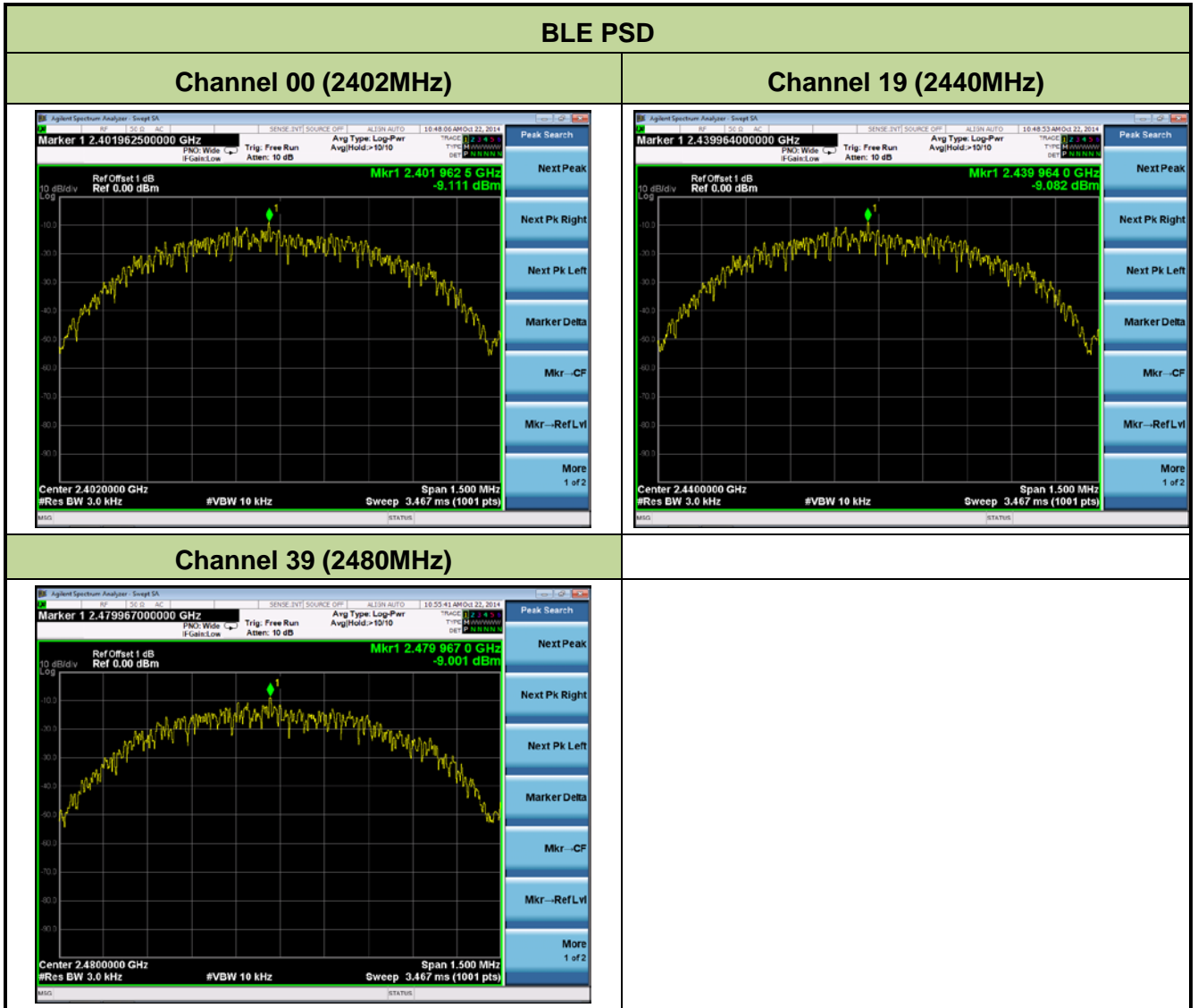

## **7.5. Conducted Band Edge and Out-of-Band Emissions**

### **7.5.1. Test Limit**

The limit for out-of-band spurious emissions at the band edge is 20dB below the fundamental emission level, as determined from the in-band power measurement of the DTS channel performed in a 100kHz bandwidth per the PSD procedure (Section 9.1).

### **7.5.2. Test Procedure Used**

KDB 558074 D01v03r02 - Section 11.2 & Section 11.3

### **7.5.3. Test Setting**

#### **1. Reference level measurement**

- (a) Set instrument center frequency to DTS channel center frequency
- (b) Set the span to  $\geq 1.5$  times the DTS bandwidth
- (c) Set the RBW = 100 kHz
- (d) Set the VBW  $\geq 3 \times$  RBW
- (e) Detector = peak
- (f) Sweep time = auto couple
- (g) Trace mode = max hold
- (h) Allow trace to fully stabilize

#### **2. Emission level measurement**

- (a) Set the center frequency and span to encompass frequency range to be measured
- (b) RBW = 100kHz
- (c) VBW = 300kHz
- (d) Detector = Peak
- (e) Number of sweep points  $\geq 2 \times$  Span/RBW
- (f) Trace mode = max hold
- (g) Sweep time = auto couple

(h) The trace was allowed to stabilize

### 7.5.4. Test Setup

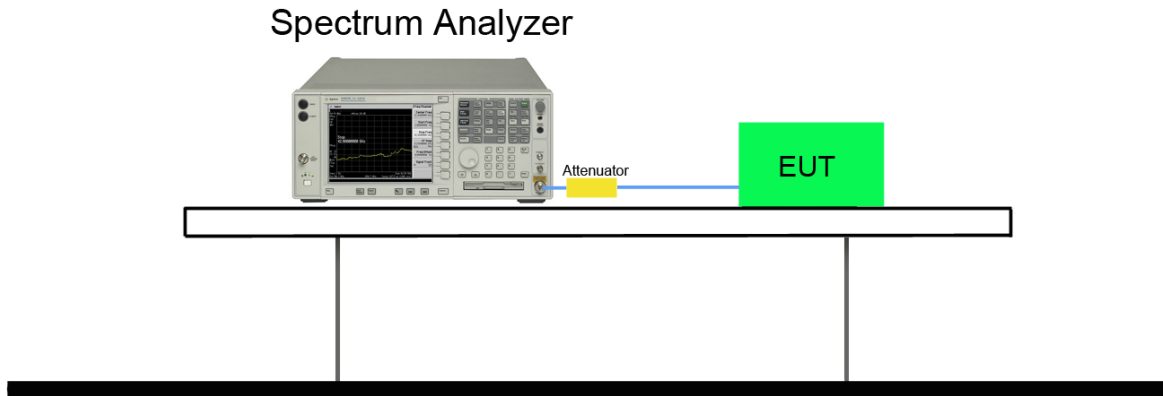

**7.5.5. Test Result**

Test Mode	Data Rate (Mbps)	Channel No.	Frequency (MHz)	Limit	Result
802.11b	1	01	2412	20dBc	Pass
802.11b	1	06	2437	20dBc	Pass
802.11b	1	11	2462	20dBc	Pass
802.11g	6	01	2412	20dBc	Pass
802.11g	6	06	2437	20dBc	Pass
802.11g	6	11	2462	20dBc	Pass
802.11n-HT20	6.5	01	2412	20dBc	Pass
802.11n-HT20	6.5	06	2437	20dBc	Pass
802.11n-HT20	6.5	11	2462	20dBc	Pass
BLE	1	00	2402	20dBc	Pass
BLE	1	19	2440	20dBc	Pass
BLE	1	39	2480	20dBc	Pass

**802.11b Out-of-Band Emissions**
**Channel 01 (2412MHz)**
**100kHz PSD reference Level**

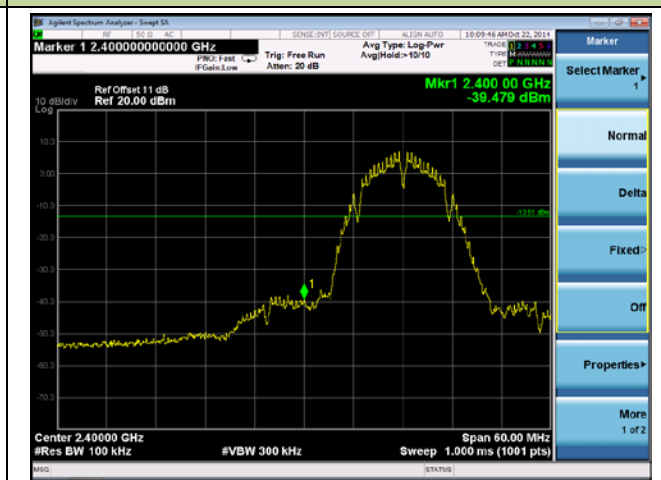
**Low Band Edge**

### Spurious Emission 30MHz ~ 25GHz

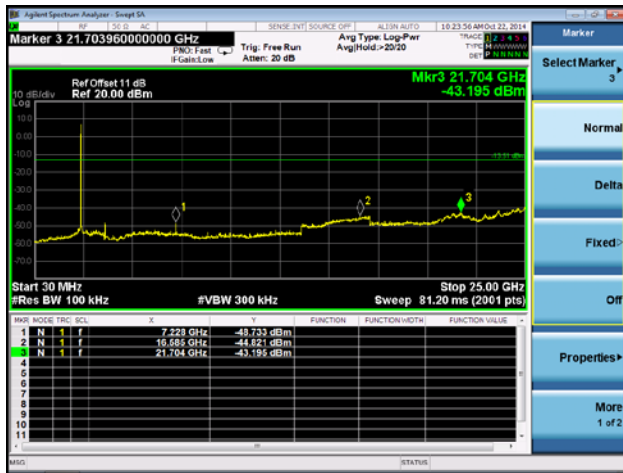

### Channel 06 (2437MHz)

#### 100kHz PSD reference Level



#### Spurious Emission 30MHz ~ 25GHz

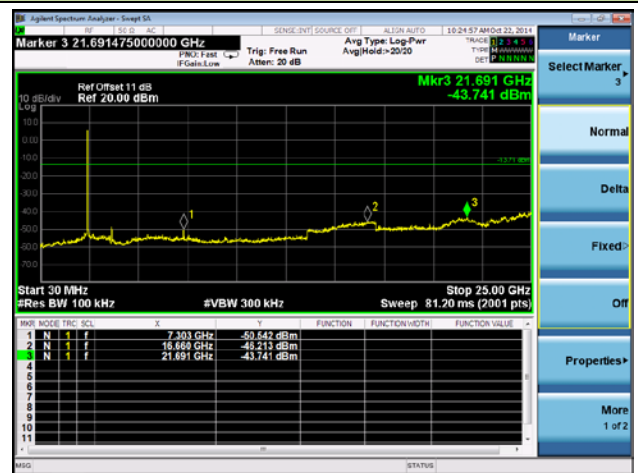

### Channel 11 (2462MHz)

#### 100kHz PSD reference Level

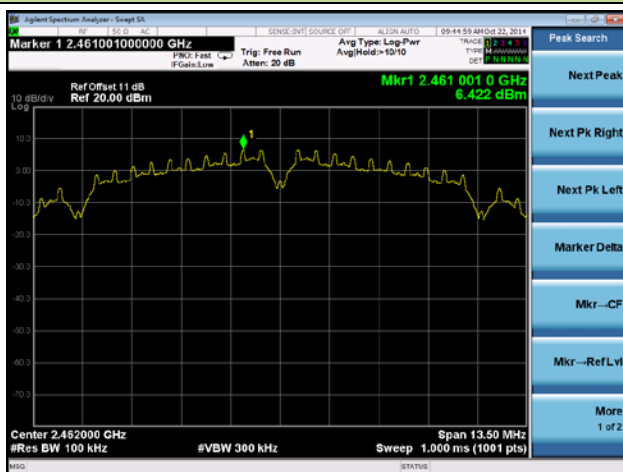

#### High Band Edge

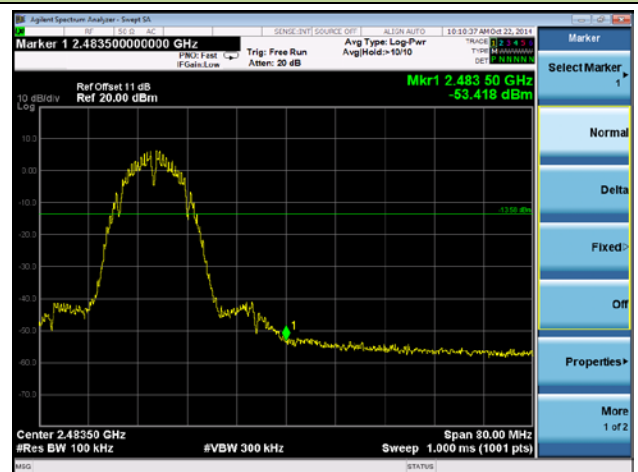



### Spurious Emission 30MHz ~ 25GHz

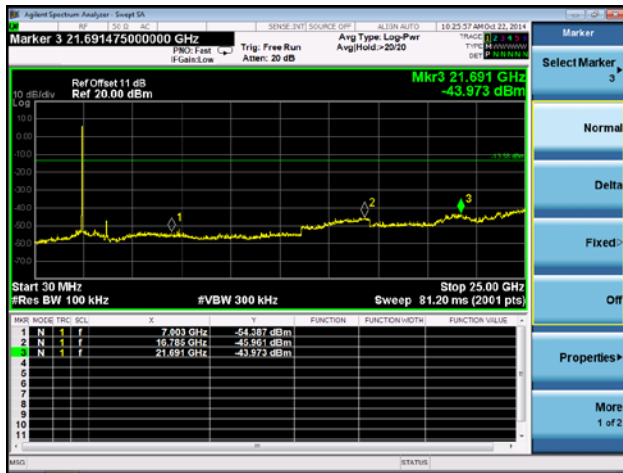

### 802.11g Out-of-Band Emissions

#### Channel 01 (2412MHz)

#### 100kHz PSD reference Level

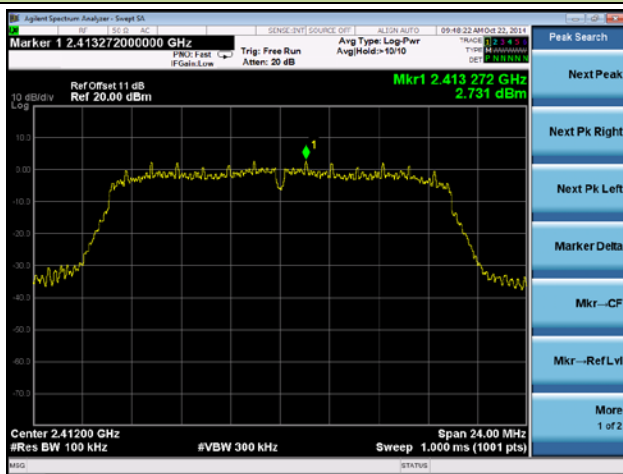

#### Low Band Edge

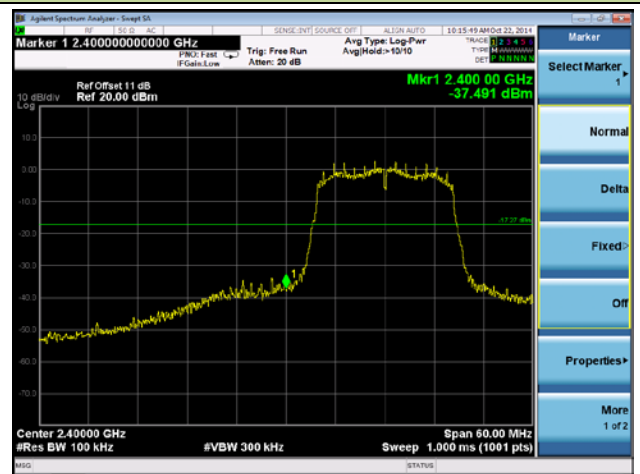

### Spurious Emission 30MHz ~ 25GHz

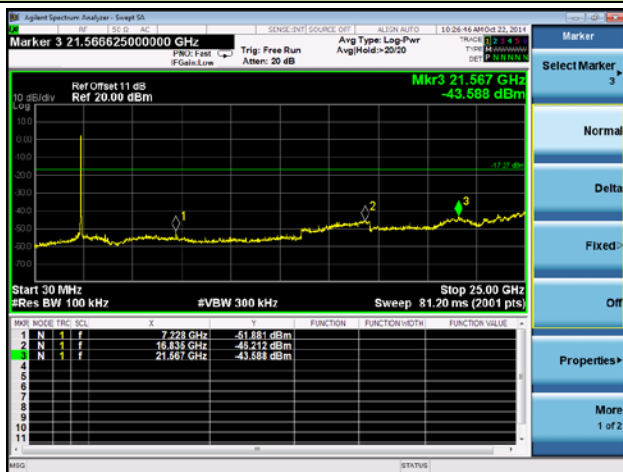

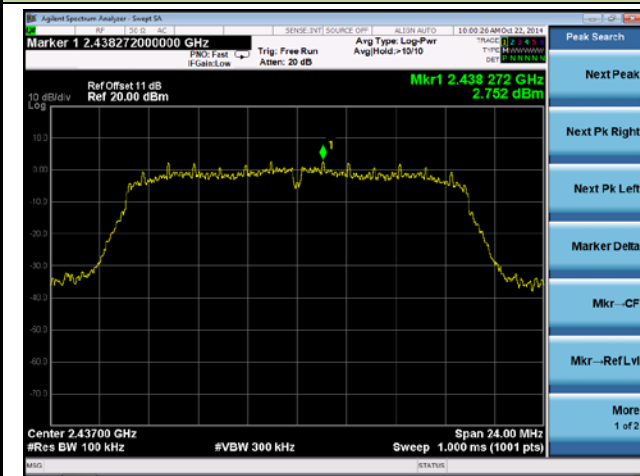
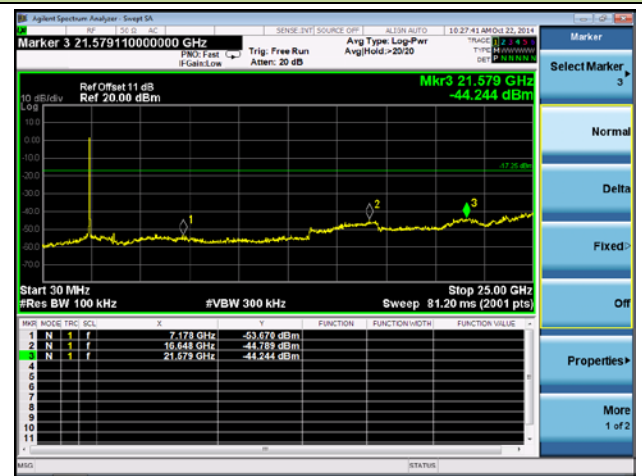
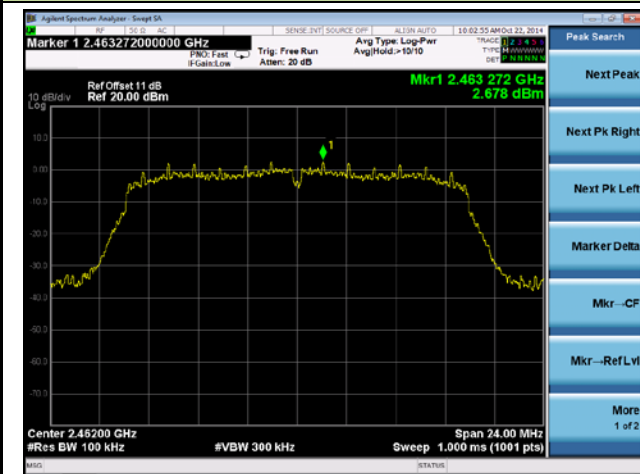
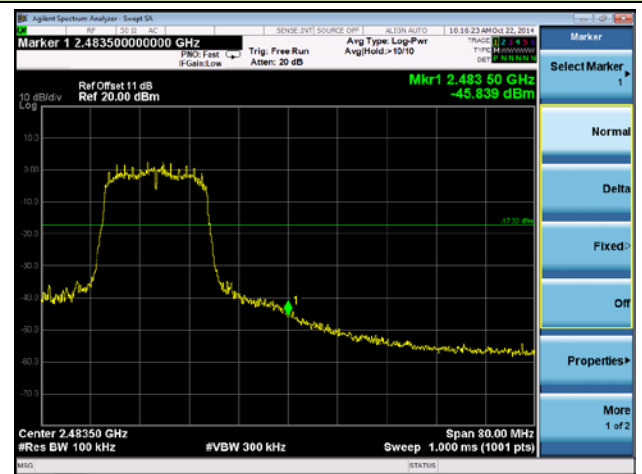
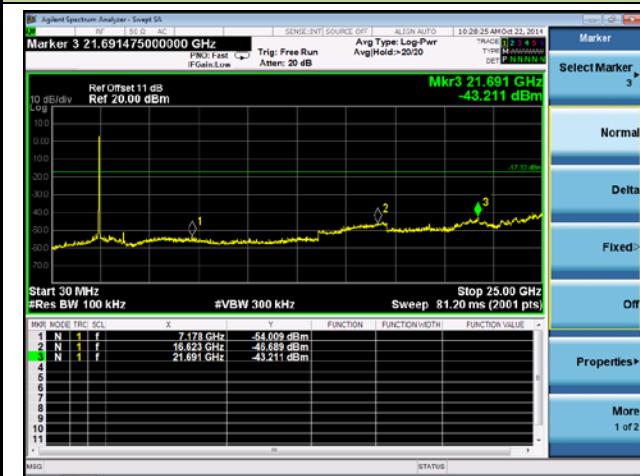
**Channel 06 (2437MHz)**
**100kHz PSD reference Level**

**Spurious Emission 30MHz ~ 25GHz**

**Channel 11 (2462MHz)**
**100kHz PSD reference Level**

**High Band Edge**

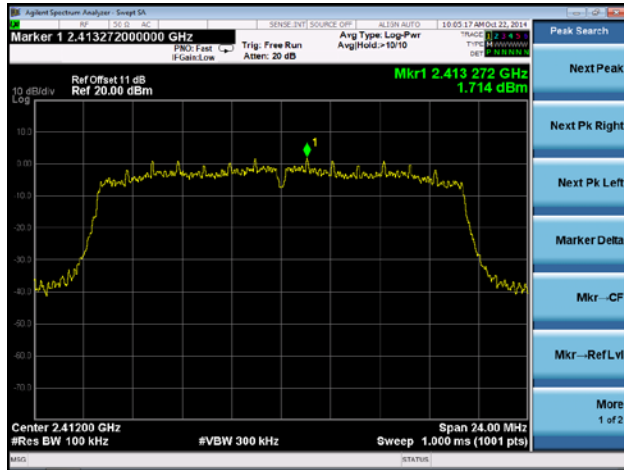
**Spurious Emission 30MHz ~ 25GHz**

### 802.11n-HT20 Out-of-Band Emissions

#### Channel 01 (2412MHz)

##### 100kHz PSD reference Level



##### Low Band Edge

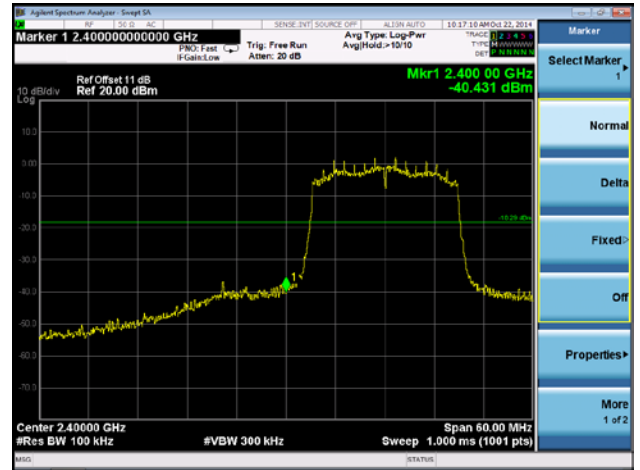

##### Spurious Emission 30MHz ~ 25GHz

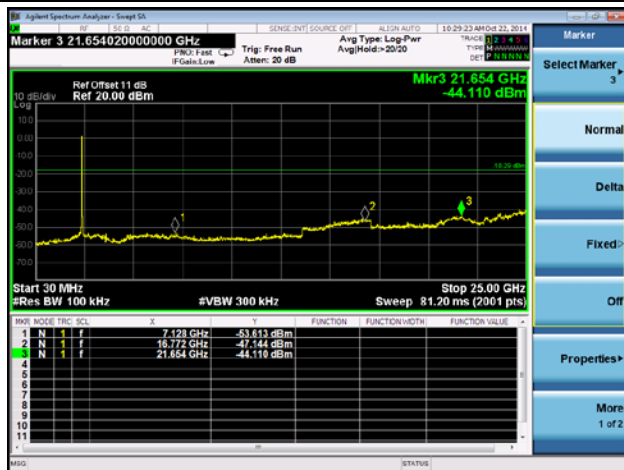

#### Channel 06 (2437MHz)

##### 100kHz PSD reference Level

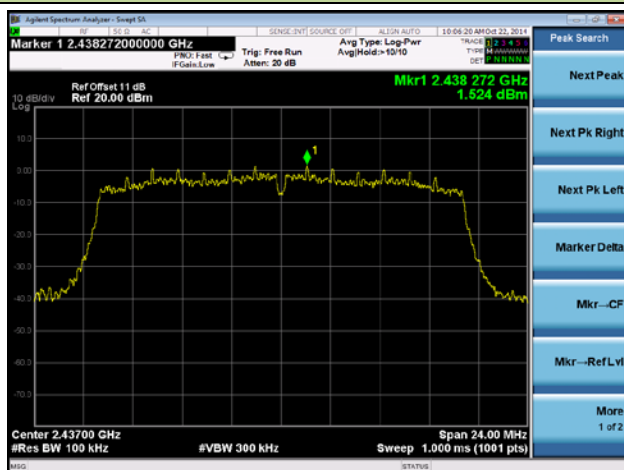

##### Spurious Emission 30MHz ~ 25GHz

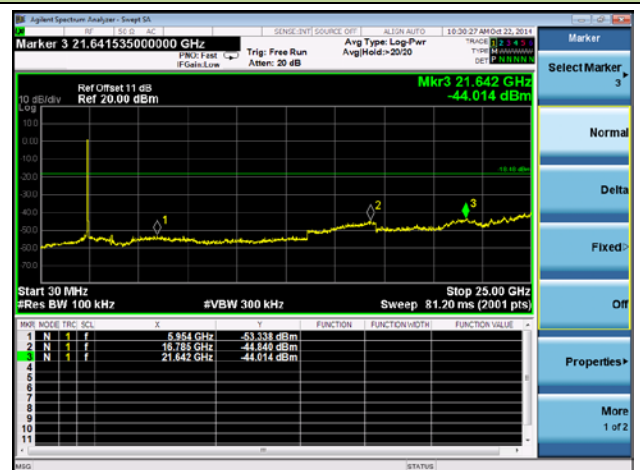

### Channel 11 (2462MHz)

#### 100kHz PSD reference Level

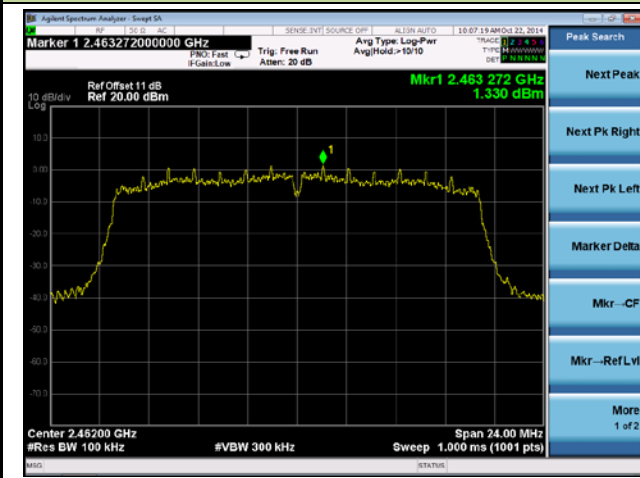

#### High Band Edge

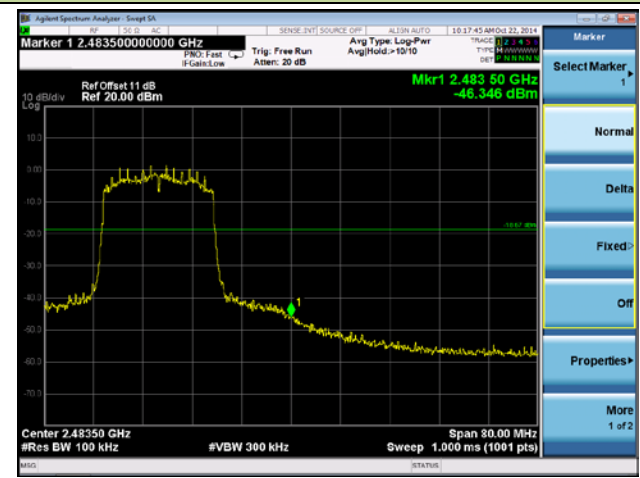

#### Spurious Emission 30MHz ~ 25GHz



### BLE Out-of-Band Emissions

#### Channel 00 (2402MHz)

##### 100kHz PSD reference Level



##### Low Band Edge



##### Spurious Emission 30MHz ~ 25GHz

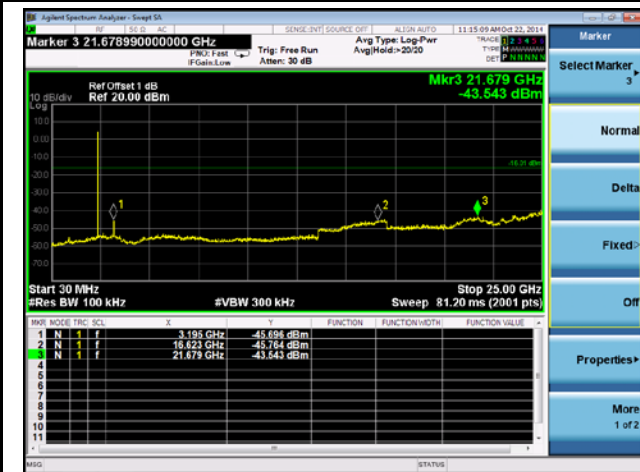

### Channel 19 (2440MHz)

#### 100kHz PSD reference Level



#### Spurious Emission 30MHz ~ 25GHz

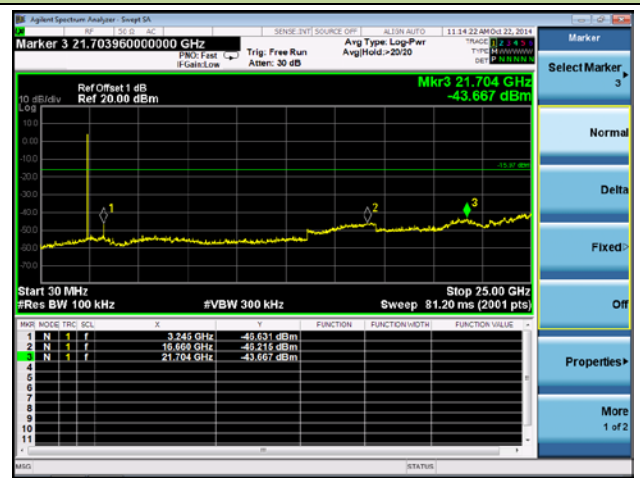

### Channel 39 (2480MHz)

#### 100kHz PSD reference Level

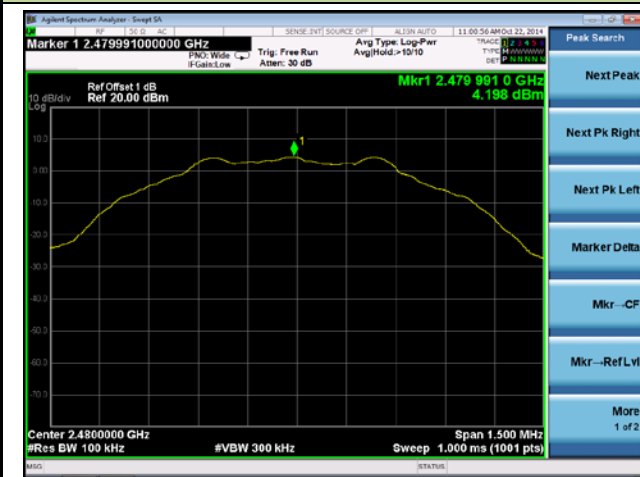

#### High Band Edge

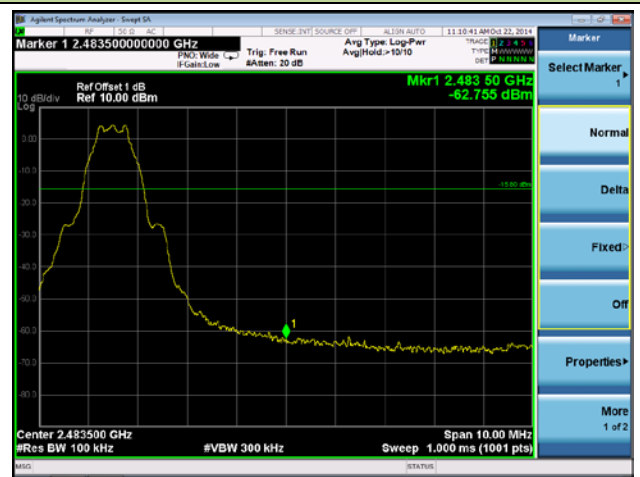

### Spurious Emission 30MHz ~ 25GHz

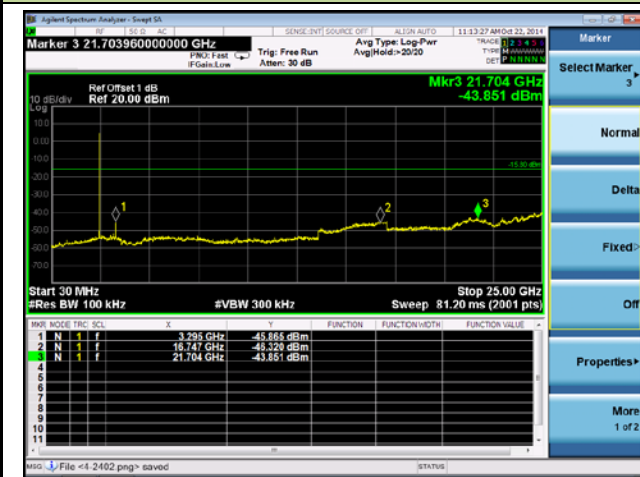

## 7.6. Radiated Spurious Emission Measurement

### 7.6.1. Test Limit

All out of band emissions appearing in a restricted band as specified in Section 15.205 of the Title 47 CFR must not exceed the limits shown in Table per Section 15.209.

FCC Part 15 Subpart C Paragraph 15.209		
Frequency [MHz]	Field Strength [V/m]	Measured Distance [Meters]
0.009 - 0.490	2400/F (kHz)	300
0.490 - 1.705	24000/F (kHz)	30
1.705 - 30	30	30
30 - 88	100	3
88 - 216	150	3
216 - 960	200	3
Above 960	500	3

### 7.6.2. Test Procedure Used

KDB 558074 D01v03r02 - Section 12.2.3 (quasi-peak measurements)

KDB 558074 D01v03r02 - Section 12.2.4 (peak power measurements)

KDB 558074 D01v03r02 - Section 12.2.5 (average power measurements)

### 7.6.3. Test Setting

#### Peak Field Strength Measurements per Section 12.2.4 of KDB 558074 D01v03r02

1. Analyzer center frequency was set to the frequency of the radiated spurious emission of interest
2. RBW = as specified in Table 1
3. VBW = 3MHz
4. Detector = peak
5. Sweep time = auto couple

6. Trace mode = max hold
7. Trace was allowed to stabilize

**Table 1 - RBW as a function of frequency**

Frequency	RBW
9 ~ 150 kHz	200 ~ 300 Hz
0.15 ~ 30 MHz	9 ~ 10 kHz
30 ~ 1000 MHz	100 ~ 120 kHz
> 1000 MHz	1 MHz

**Average Field Strength Measurements per Section 12.2.5.1 of KDB 558074 D01v03r02**

1. Analyzer center frequency was set to the frequency of the radiated spurious emission of interest
2. RBW = 1MHz
3. VBW  $\geq$  1/T
4. De As an alternative, the instrument may be set to linear detector mode. Ensure that video filtering is applied in linear voltage domain (rather than in a log or dB domain). Some instruments require linear display mode in order to accomplish this. Others have a setting for Average-VBW Type, which can be set to "Voltage" regardless of the display mode
5. Detector = Peak
6. Sweep time = auto
7. Trace mode = max hold
8. Allow max hold to run for at least 50 times (1/duty cycle) traces



### 7.6.4. Test Setup

#### 9kHz ~ 30MHz Test Setup:

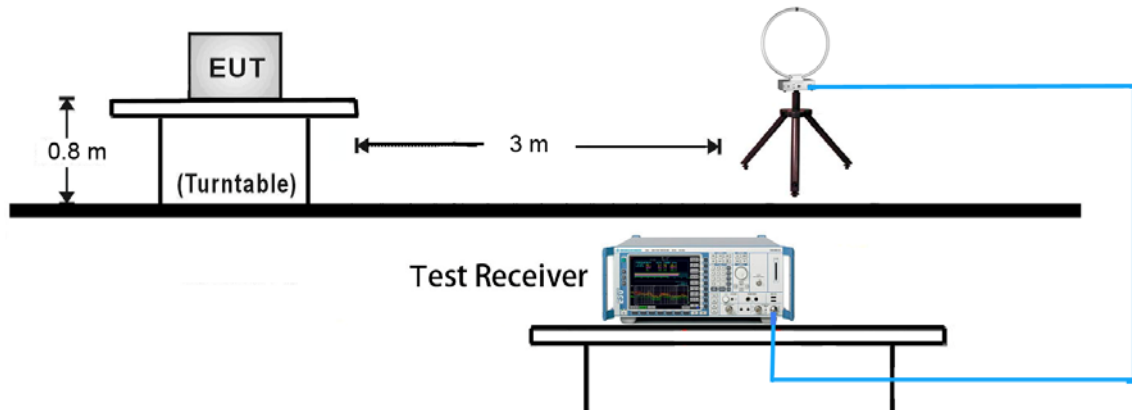

#### 30MHz ~ 1GHz Test Setup:

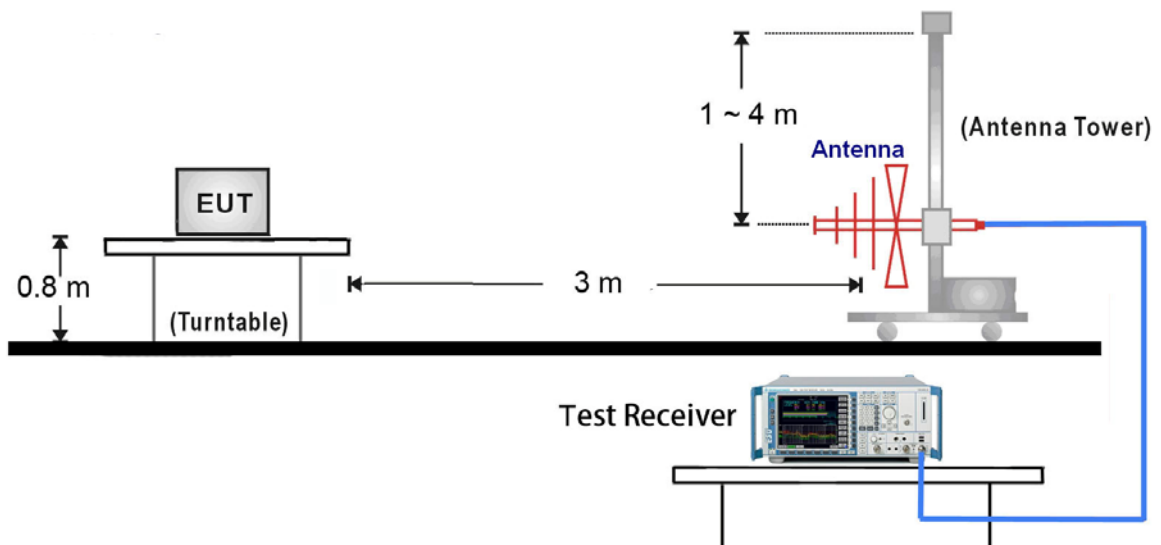

1GHz ~ 25GHz Test Setup:

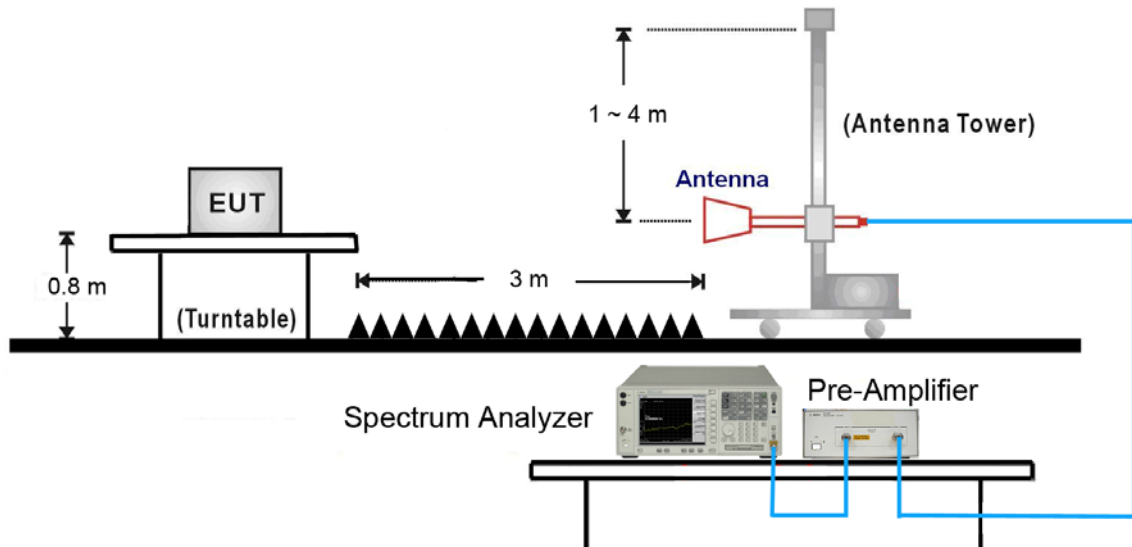

### 7.6.5. Test Result

Test Mode:	802.11b	Test Site:	AC1
Test Channel:	06	Test Engineer:	Roy Cheng
Remark:	1. Average measurement was not performed if peak level lower than average limit. 2. <b>The worst case of Radiated Spurious Emission.</b> 3. Other frequency was 20dB below limit line within 1-18GHz, there is not show in the report.		

Mark	Frequency (MHz)	Reading Level (dB $\mu$ V)	Factor (dB)	Measure Level (dB $\mu$ V/m)	Limit (dB $\mu$ V/m)	Margin (dB)	Detector	Polarization
*	3025.3	36.4	3.4	39.8	83.7	-43.9	Peak	Horizontal
*	4425.6	37.4	5.5	42.9	83.7	-40.8	Peak	Horizontal
	4874.0	37.3	6.6	43.9	74.0	-30.1	Peak	Horizontal
	7311.0	35.5	13.9	49.4	74.0	-24.6	Peak	Horizontal
*	3142.9	36.7	3.6	40.3	83.7	-43.4	Peak	Vertical
*	4419.3	37.4	5.5	42.9	83.7	-40.8	Peak	Vertical
	4874.0	37.4	6.6	44.0	74.0	-30.0	Peak	Vertical
	7311.0	35.5	13.9	49.4	74.0	-24.6	Peak	Vertical

Note 1: "\*" is not in restricted band, its limit is 20dBc of the fundamental emission level (103.7dB $\mu$ V/m).

Note 2: Measure Level (dB $\mu$ V/m) = Reading Level (dB $\mu$ V) + Factor (dB)

Factor (dB) = Cable Loss (dB) + Antenna Factor (dB/m) - Pre\_Amplifier Gain (dB)

Test Mode:	BLE	Test Site:	AC1
Test Channel:	39	Test Engineer:	Roy Cheng
Remark:	1. Average measurement was not performed if peak level lower than average limit. 2. <b>The worst case of Radiated Spurious Emission.</b> 3. Other frequency was 20dB below limit line within 1-18GHz, there is not show in the report.		

Mark	Frequency (MHz)	Reading Level (dBμV)	Factor (dB)	Measure Level (dBμV/m)	Limit (dBμV/m)	Margin (dB)	Detector	Polarization
*	3056.3	35.9	3.4	39.3	78.9	-39.6	Peak	Horizontal
*	4429.6	36.2	5.5	41.7	78.9	-37.2	Peak	Horizontal
	4880.0	36.6	6.6	43.2	74.0	-30.8	Peak	Horizontal
	7320.0	34.4	14.0	48.4	74.0	-25.6	Peak	Horizontal
*	3102.5	35.8	3.4	39.3	78.9	-39.6	Peak	Vertical
*	4432.0	36.4	5.5	41.9	78.9	-37.0	Peak	Vertical
	4880.0	36.1	6.6	42.7	74.0	-31.3	Peak	Vertical
	7320.0	33.9	14.0	47.9	74.0	-26.1	Peak	Vertical

Note 1: "\*" is not in restricted band, its limit is 20dBc of the fundamental emission level (98.9dBμV/m).

Note 2: Measure Level (dBμV/m) = Reading Level (dBμV) + Factor (dB)

Factor (dB) = Cable Loss (dB) + Antenna Factor (dB/m) - Pre\_Amplifier Gain (dB)

**The worst case of Radiated Emission below 1GHz:**

Engineer: Roy Cheng	
Site: AC1	Time: 2014/10/22 - 17:03
Limit: FCC_Part15.209_RE(3m)	Margin: 0
Probe: VULB9162_0.03-8GHz	Polarity: Horizontal
EUT: Tablet PC	Power: AC 120V/60Hz
<b>Worst Test Mode:</b> Transmit at channel 2462MHz by 802.11b	

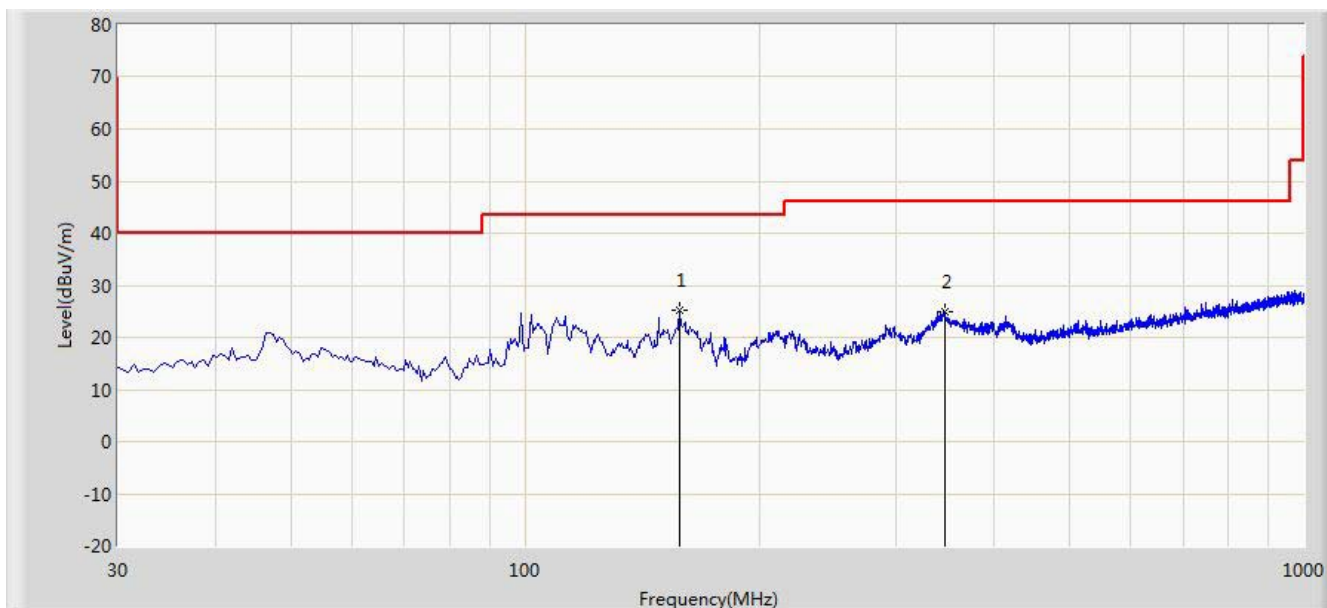

No	Flag	Mark	Frequency (MHz)	Measure Level (dBuV/m)	Reading Level (dBuV)	Over Limit (dB)	Limit (dBuV/m)	Factor (dB)	Type
1		*	158.040	25.321	15.877	-18.179	43.500	9.444	QP
2			346.705	24.919	9.597	-21.081	46.000	15.323	QP

Note: Measure Level (dB $\mu$ V/m) = Reading Level (dB $\mu$ V) + Factor (dB)

Factor (dB) = Cable Loss (dB) + Antenna Factor (dB/m)

Engineer: Roy Cheng	
Site: AC1	Time: 2014/10/22 - 17:05
Limit: FCC_Part15.209_RE(3m)	Margin: 0
Probe: VULB9162_0.03-8GHz	Polarity: Vertical
EUT: Tablet PC	Power: AC 120V/60Hz
<b>Worst Test Mode:</b> Transmit at channel 2462MHz by 802.11b	

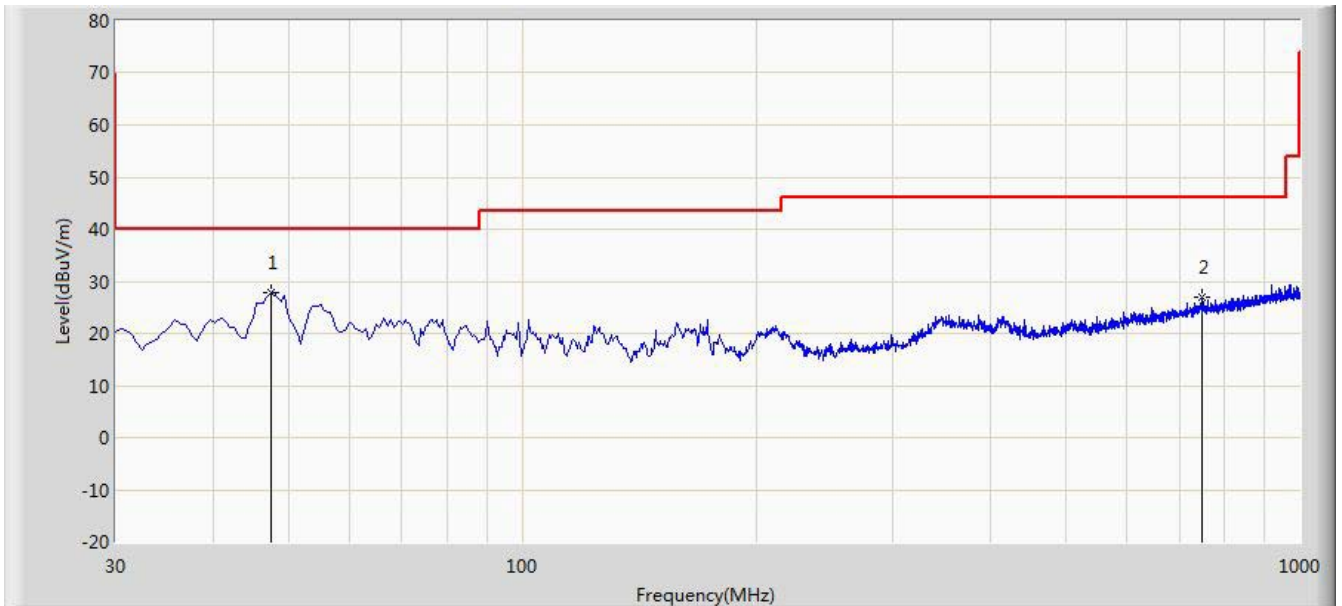

No	Flag	Mark	Frequency (MHz)	Measure Level (dBuV/m)	Reading Level (dBuV)	Over Limit (dB)	Limit (dBuV/m)	Factor (dB)	Type
1		*	47.460	27.939	13.140	-12.061	40.000	14.799	QP
2			750.225	26.896	5.363	-19.104	46.000	21.532	QP

Note: Measure Level (dBμV/m) = Reading Level (dBμV) + Factor (dB)

Factor (dB) = Cable Loss (dB) + Antenna Factor (dB/m)

Engineer: Roy Cheng	
Site: AC1	Time: 2014/10/22 - 16:39
Limit: FCC_Part15.209_RE(3m)	Margin: 0
Probe: FMZB1519_0.009-30MHz	Polarity: Face On
EUT: Tablet PC	Power: AC 120V/60Hz
<b>Note: There is the ambient noise within frequency range 9kHz~30MHz.</b>	

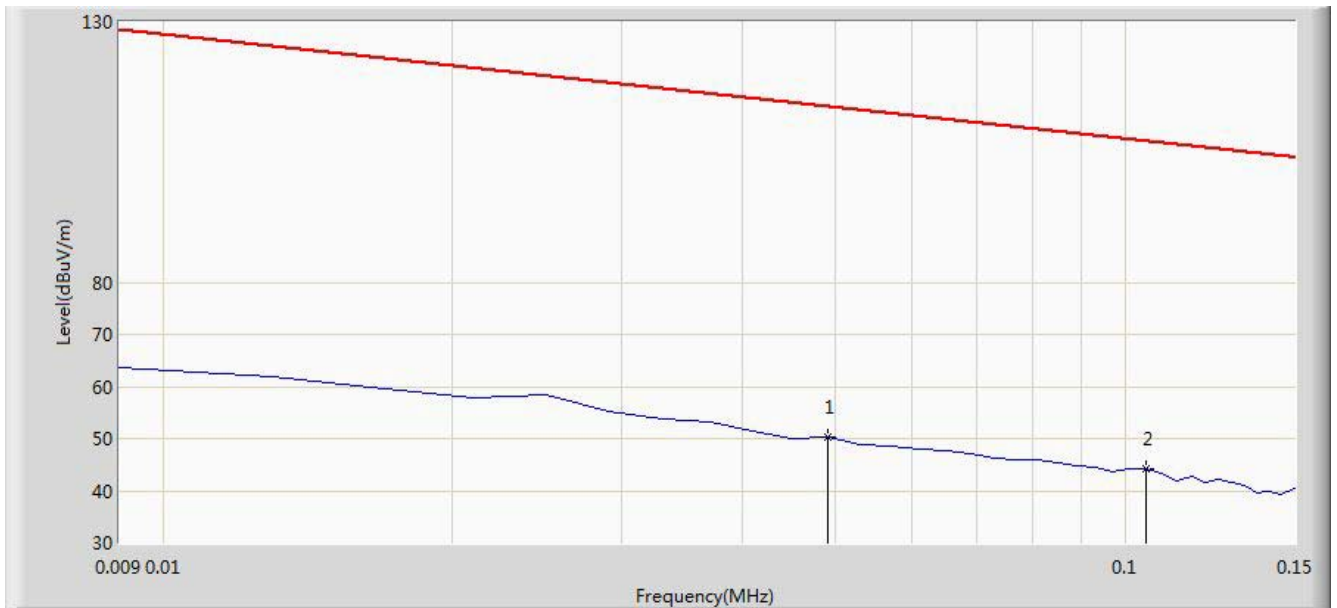

No	Flag	Mark	Frequency (MHz)	Measure Level (dBuV/m)	Reading Level (dBuV)	Over Limit (dB)	Limit (dBuV/m)	Factor (dB)	Type
1			0.049	50.367	29.861	-63.422	113.789	20.505	QP
2		*	0.105	44.143	23.996	-63.029	107.173	20.147	QP

Note: Measure Level (dB $\mu$ V/m) = Reading Level (dB $\mu$ V) + Factor (dB)

Factor (dB) = Cable Loss (dB) + Antenna Factor (dB/m)

Engineer: Roy Cheng	
Site: AC1	Time: 2014/10/22 - 16:41
Limit: FCC_Part15.209_RE(3m)	Margin: 0
Probe: FMZB1519_0.009-30MHz	Polarity: Face On
EUT: Tablet PC	Power: AC 120V/60Hz
<b>Note: There is the ambient noise within frequency range 9kHz~30MHz.</b>	

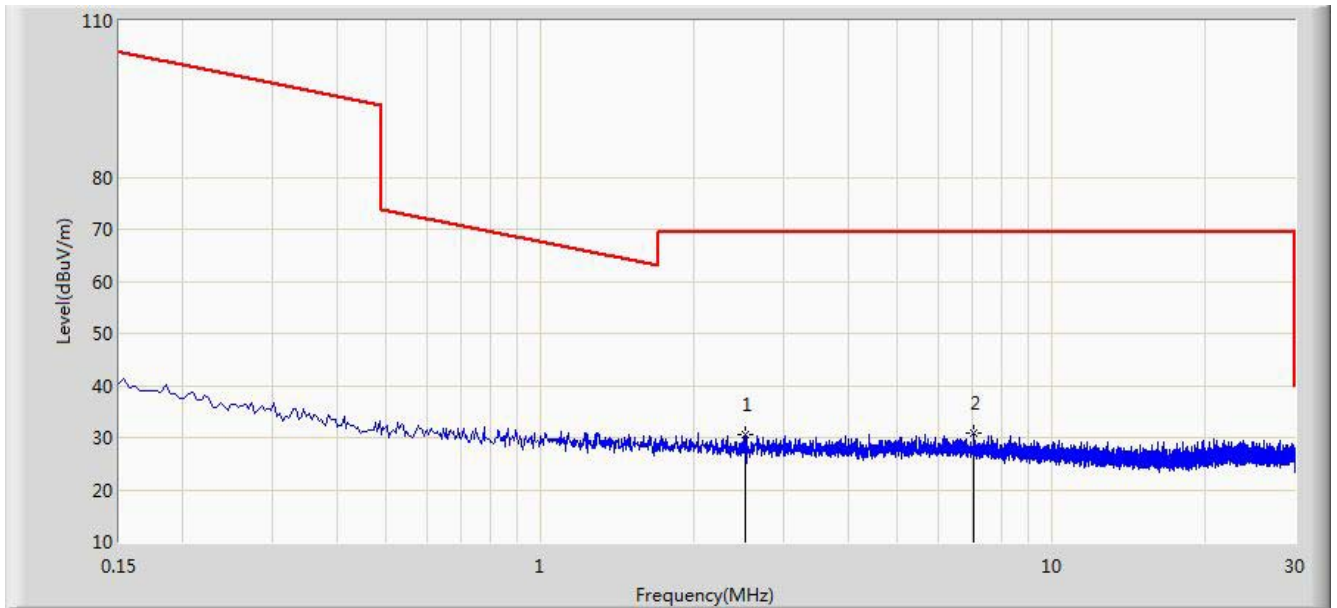

No	Flag	Mark	Frequency (MHz)	Measure Level (dBuV/m)	Reading Level (dBuV)	Over Limit (dB)	Limit (dBuV/m)	Factor (dB)	Type
1			2.513	30.495	10.336	-39.005	69.500	20.159	QP
2		*	7.041	30.974	10.579	-38.526	69.500	20.395	QP

Note: Measure Level (dBμV/m) = Reading Level (dBμV) + Factor (dB)

Factor (dB) = Cable Loss (dB) + Antenna Factor (dB/m)



Engineer: Roy Cheng	
Site: AC1	Time: 2014/10/22 - 17:39
Limit: FCC_Part15.209_RE(3m)	Margin: 0
Probe: BBHA9170_18-40GHz	Polarity: Horizontal
EUT: Tablet PC	Power: AC 120V/60Hz
<b>Note: There is the ambient noise within frequency range 18 ~ 25GHz.</b>	

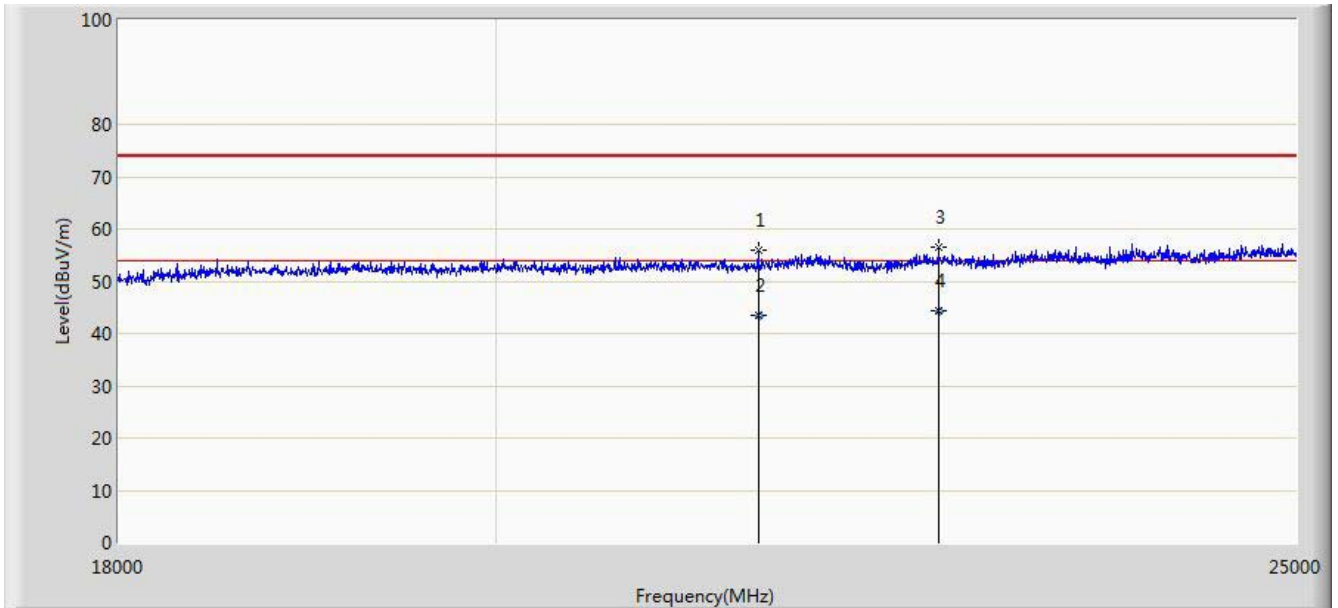

No	Flag	Mark	Frequency (MHz)	Measure Level (dBuV/m)	Reading Level (dBuV)	Over Limit (dB)	Limit (dBuV/m)	Factor (dB)	Type
1			21517.500	55.869	17.883	-18.131	74.000	37.986	PK
2			21517.650	43.351	5.365	-10.649	54.000	37.986	AV
3			22630.500	56.509	18.223	-17.491	74.000	38.286	PK
4		*	22630.540	44.310	6.024	-9.690	54.000	38.286	AV

Note: Measure Level (dB $\mu$ V/m) = Reading Level (dB $\mu$ V) + Factor (dB)

Factor (dB) = Cable Loss (dB) + Antenna Factor (dB/m)

Engineer: Roy Cheng	
Site: AC1	Time: 2014/10/22 - 17:43
Limit: FCC_Part15.209_RE(3m)	Margin: 0
Probe: BBHA9170_18-40GHz	Polarity: Vertical
EUT: Tablet PC	Power: AC 120V/60Hz
<b>Note: There is the ambient noise within frequency range 18 ~ 25GHz.</b>	

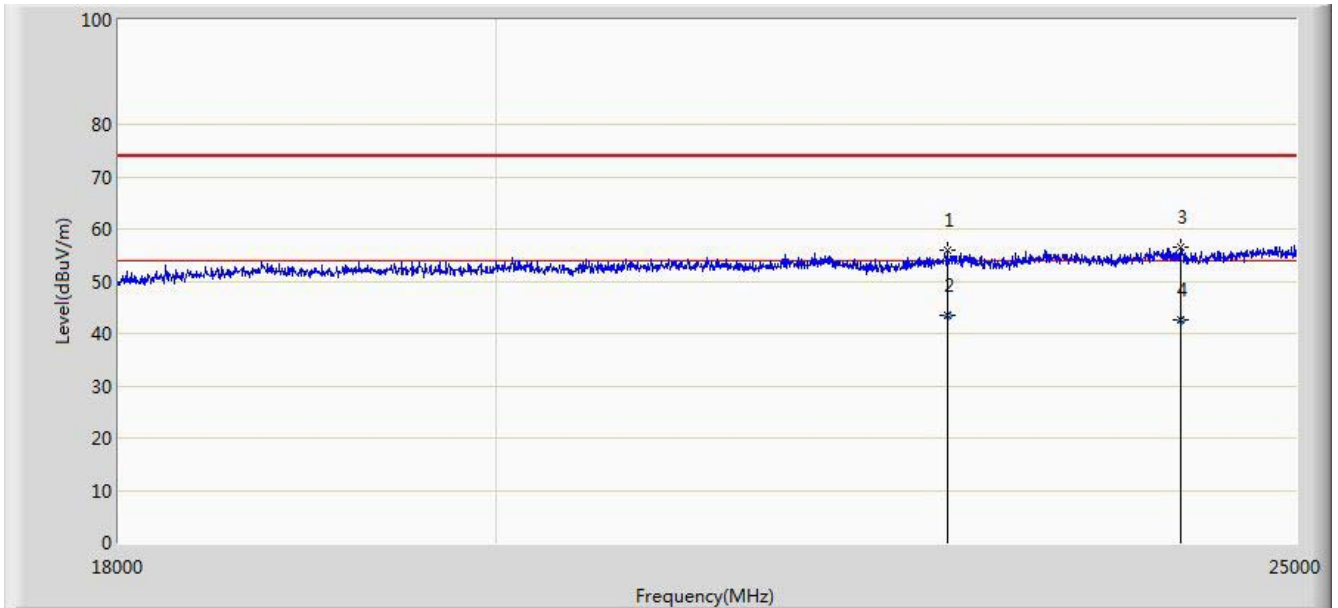

No	Flag	Mark	Frequency (MHz)	Measure Level (dBuV/m)	Reading Level (dBuV)	Over Limit (dB)	Limit (dBuV/m)	Factor (dB)	Type
1			22686.500	55.811	17.457	-18.189	74.000	38.354	PK
2		*	22686.540	43.598	5.244	-10.402	54.000	38.354	AV
3			24205.500	56.430	17.607	-17.570	74.000	38.823	PK
4			24205.658	42.518	3.695	-11.482	54.000	38.823	AV

Note: Measure Level (dBuV/m) = Reading Level (dBuV) + Factor (dB)

Factor (dB) = Cable Loss (dB) + Antenna Factor (dB/m)

## 7.7. Radiated Restricted Band Edge Measurement

### 7.7.1. Test Result

Engineer: Roy Cheng	
Site: AC1	Time: 2014/10/22 - 17:09
Limit: FCC_Part15.209_RE(3m)	Margin: 0
Probe: BBHA9120D_1-18GHz	Polarity: Horizontal
EUT: Tablet PC	Power: AC 120V/60Hz
<b>Worst Test Mode:</b> Transmit at channel 2412MHz by 802.11b	

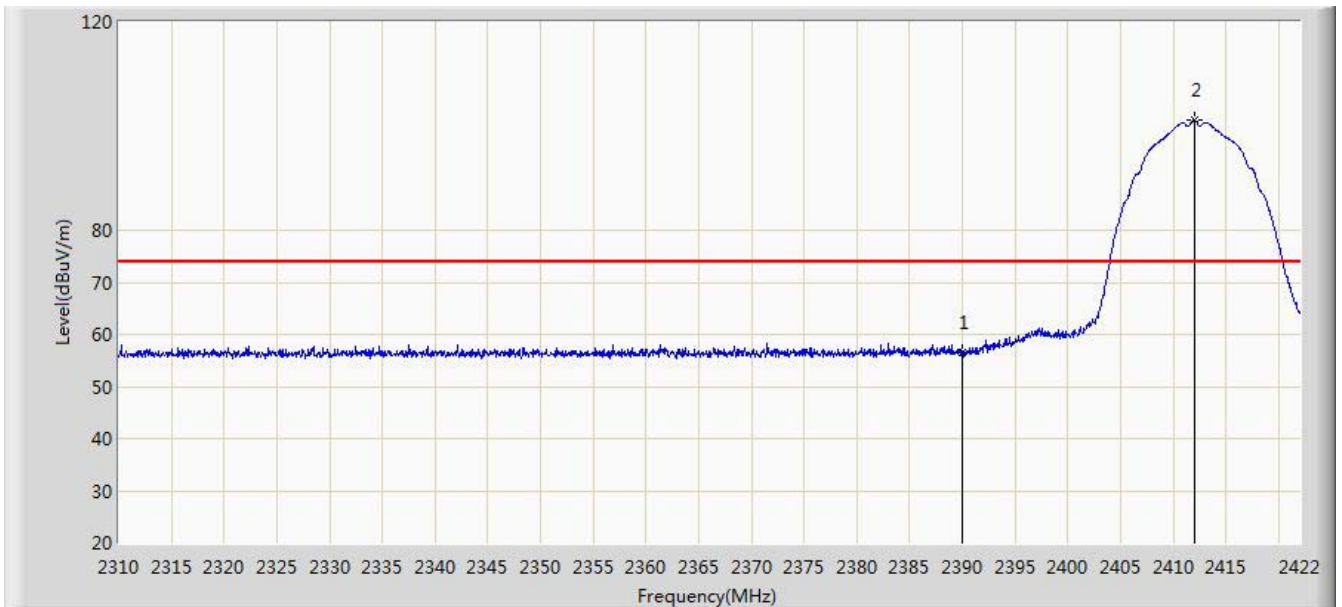

No	Flag	Mark	Frequency (MHz)	Measure Level (dBuV/m)	Reading Level (dBuV)	Over Limit (dB)	Limit (dBuV/m)	Factor (dB)	Type
1			2390.000	56.571	25.887	-17.429	74.000	30.684	PK
2		*	2412.032	101.153	70.508	N/A	N/A	30.645	PK

Note: Measure Level (dBμV/m) = Reading Level (dBμV) + Factor (dB)

Factor (dB) = Cable Loss (dB) + Antenna Factor (dB/m)

Engineer: Roy Cheng	
Site: AC1	Time: 2014/10/22 - 17:22
Limit: FCC_Part15.209_RE(3m)	Margin: 0
Probe: BBHA9120D_1-18GHz	Polarity: Horizontal
EUT: Tablet PC	Power: AC 120V/60Hz
<b>Worst Test Mode:</b> Transmit at channel 2412MHz by 802.11b	

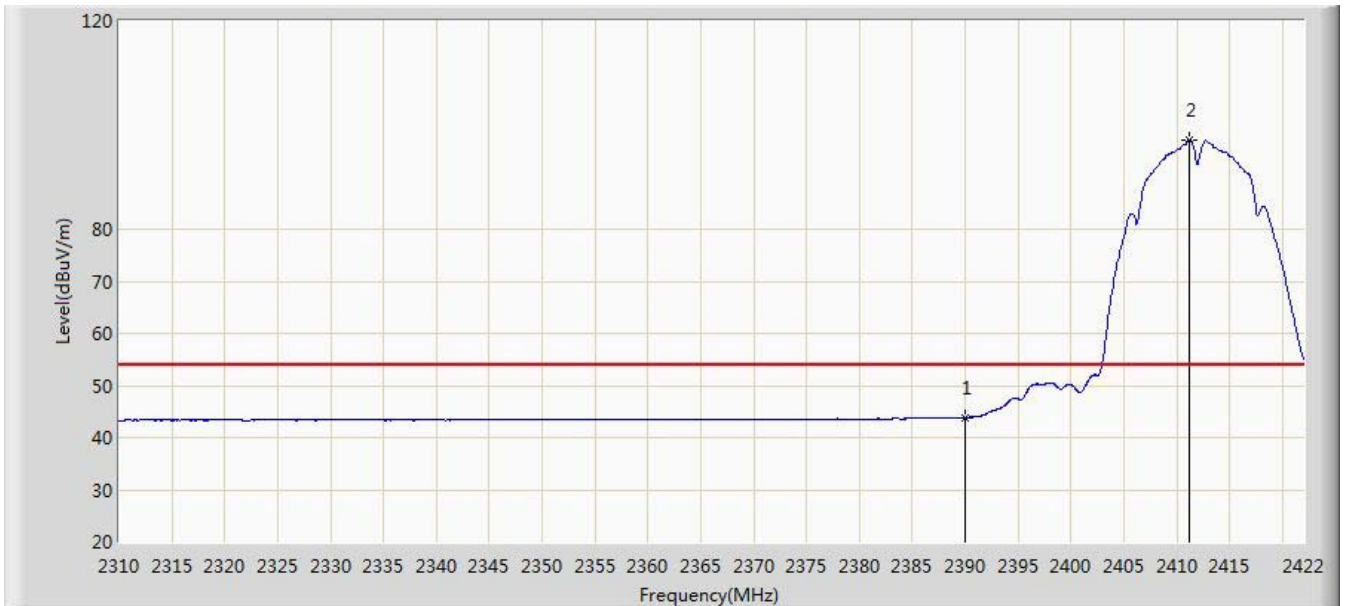

No	Flag	Mark	Frequency (MHz)	Measure Level (dBuV/m)	Reading Level (dBuV)	Over Limit (dB)	Limit (dBuV/m)	Factor (dB)	Type
1			2390.000	43.792	13.108	-10.208	54.000	30.684	AV
2		*	2411.136	97.082	66.436	N/A	N/A	30.646	AV

Note: Measure Level (dBμV/m) = Reading Level (dBμV) + Factor (dB)

Factor (dB) = Cable Loss (dB) + Antenna Factor (dB/m)

Engineer: Roy Cheng	
Site: AC1	Time: 2014/10/22 - 17:22
Limit: FCC_Part15.209_RE(3m)	Margin: 0
Probe: BBHA9120D_1-18GHz	Polarity: Vertical
EUT: Tablet PC	Power: AC 120V/60Hz
<b>Worst Test Mode:</b> Transmit at channel 2412MHz by 802.11b	

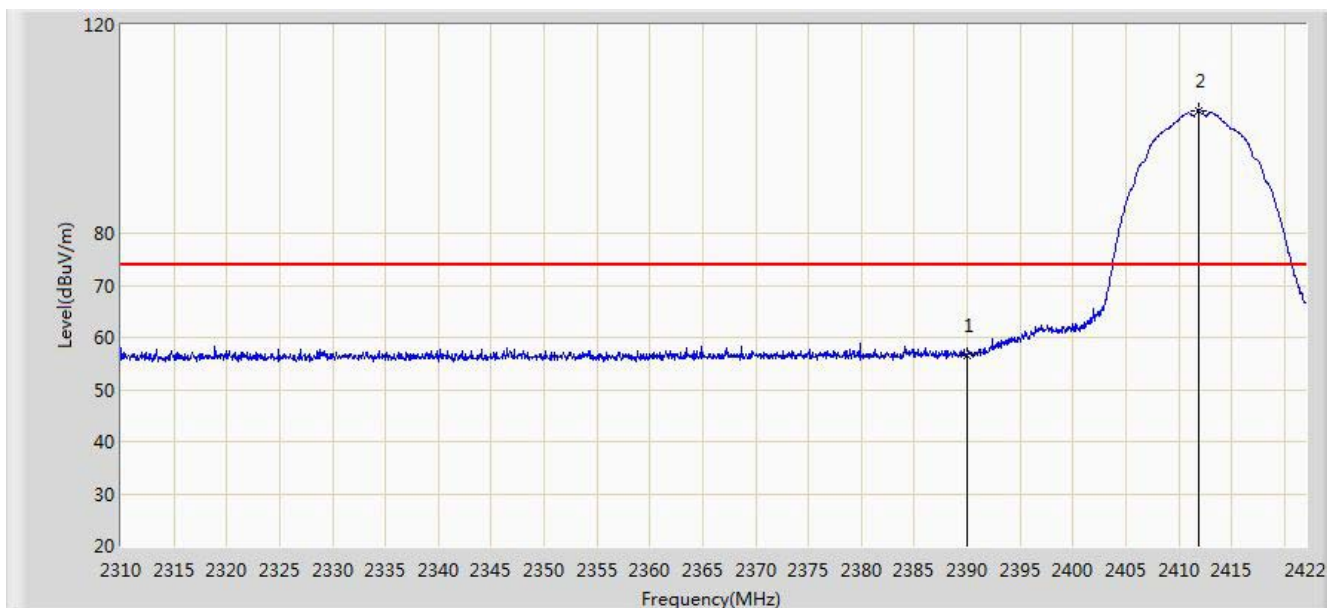

No	Flag	Mark	Frequency (MHz)	Measure Level (dBuV/m)	Reading Level (dBuV)	Over Limit (dB)	Limit (dBuV/m)	Factor (dB)	Type
1			2390.000	56.600	25.916	-17.400	74.000	30.684	PK
2		*	2411.864	103.598	72.953	N/A	N/A	30.645	PK

Note: Measure Level (dB $\mu$ V/m) = Reading Level (dB $\mu$ V) + Factor (dB)

Factor (dB) = Cable Loss (dB) + Antenna Factor (dB/m)

Engineer: Roy Cheng	
Site: AC1	Time: 2014/10/22 - 17:23
Limit: FCC_Part15.209_RE(3m)	Margin: 0
Probe: BBHA9120D_1-18GHz	Polarity: Vertical
EUT: Tablet PC	Power: AC 120V/60Hz
<b>Worst Test Mode:</b> Transmit at channel 2412MHz by 802.11b	

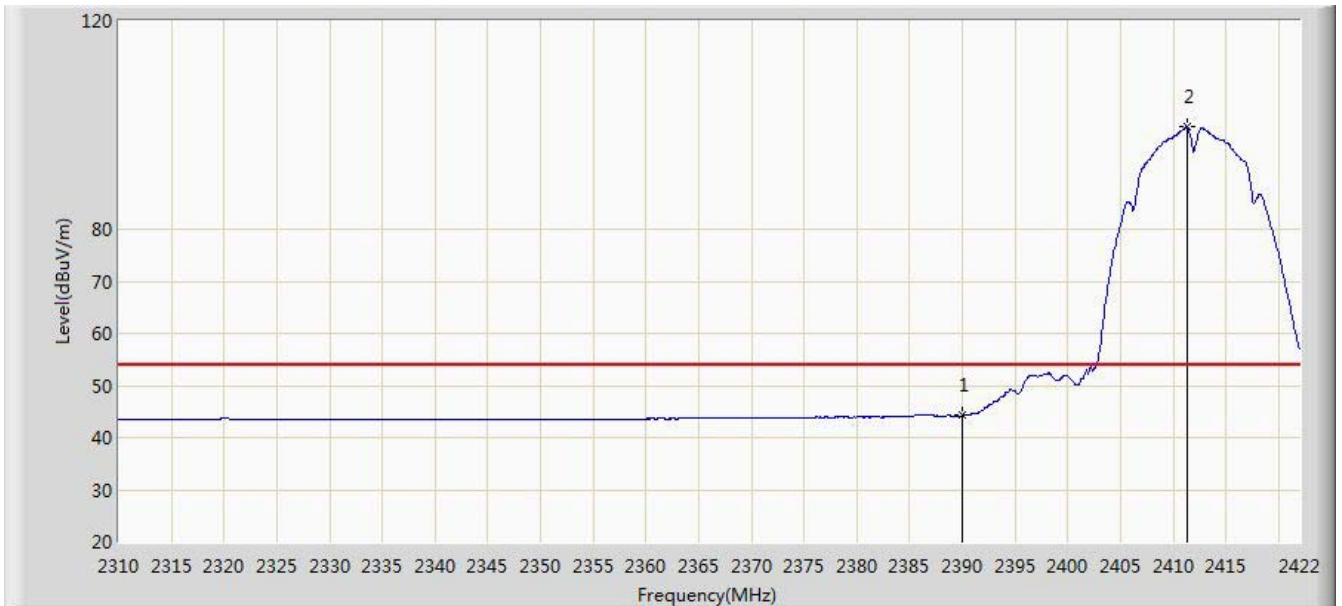

No	Flag	Mark	Frequency (MHz)	Measure Level (dBuV/m)	Reading Level (dBuV)	Over Limit (dB)	Limit (dBuV/m)	Factor (dB)	Type
1			2390.000	44.231	13.547	-9.769	54.000	30.684	AV
2		*	2411.304	99.681	69.035	N/A	N/A	30.646	AV

Note: Measure Level (dBμV/m) = Reading Level (dBμV) + Factor (dB)

Factor (dB) = Cable Loss (dB) + Antenna Factor (dB/m)

Engineer: Roy Cheng	
Site: AC1	Time: 2014/10/22 - 17:27
Limit: FCC_Part15.209_RE(3m)	Margin: 0
Probe: BBHA9120D_1-18GHz	Polarity: Horizontal
EUT: Tablet PC	Power: AC 120V/60Hz
<b>Worst Test Mode:</b> Transmit at channel 2412MHz by 802.1120	

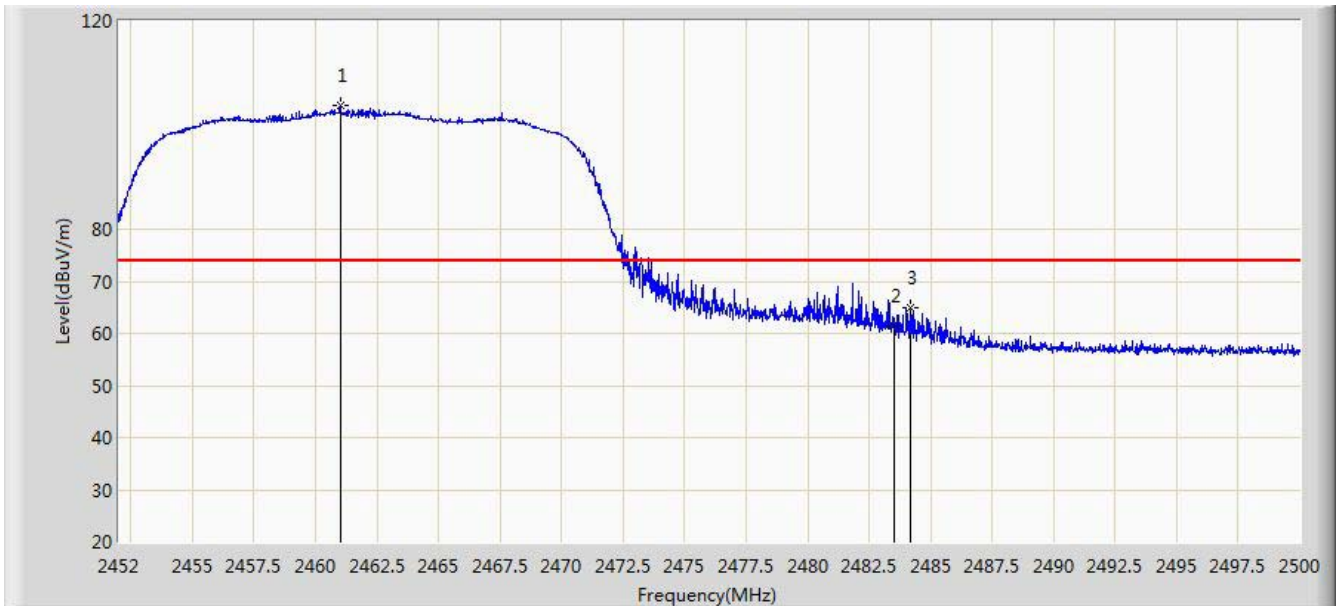

No	Flag	Mark	Frequency (MHz)	Measure Level (dBuV/m)	Reading Level (dBuV)	Over Limit (dB)	Limit (dBuV/m)	Factor (dB)	Type
1		*	2461.000	103.825	73.215	N/A	N/A	30.609	PK
2			2483.500	61.560	30.887	-12.440	74.000	30.673	PK
3			2484.184	64.826	34.151	-9.174	74.000	30.675	PK

Note: Measure Level (dBuV/m) = Reading Level (dBuV) + Factor (dB)

Factor (dB) = Cable Loss (dB) + Antenna Factor (dB/m)

Engineer: Roy Cheng	
Site: AC1	Time: 2014/10/22 - 17:29
Limit: FCC_Part15.209_RE(3m)	Margin: 0
Probe: BBHA9120D_1-18GHz	Polarity: Horizontal
EUT: Tablet PC	Power: AC 120V/60Hz
<b>Worst Test Mode:</b> Transmit at channel 2412MHz by 802.1120	



No	Flag	Mark	Frequency (MHz)	Measure Level (dBuV/m)	Reading Level (dBuV)	Over Limit (dB)	Limit (dBuV/m)	Factor (dB)	Type
1		*	2461.072	90.968	60.358	N/A	N/A	30.610	AV
2			2483.500	46.203	15.530	-7.797	54.000	30.673	AV

Note: Measure Level (dB $\mu$ V/m) = Reading Level (dB $\mu$ V) + Factor (dB)

Factor (dB) = Cable Loss (dB) + Antenna Factor (dB/m)



Engineer: Roy Cheng	
Site: AC1	Time: 2014/10/22 - 17:30
Limit: FCC_Part15.209_RE(3m)	Margin: 0
Probe: BBHA9120D_1-18GHz	Polarity: Vertical
EUT: Tablet PC	Power: AC 120V/60Hz
<b>Worst Test Mode:</b> Transmit at channel 2412MHz by 802.1120	

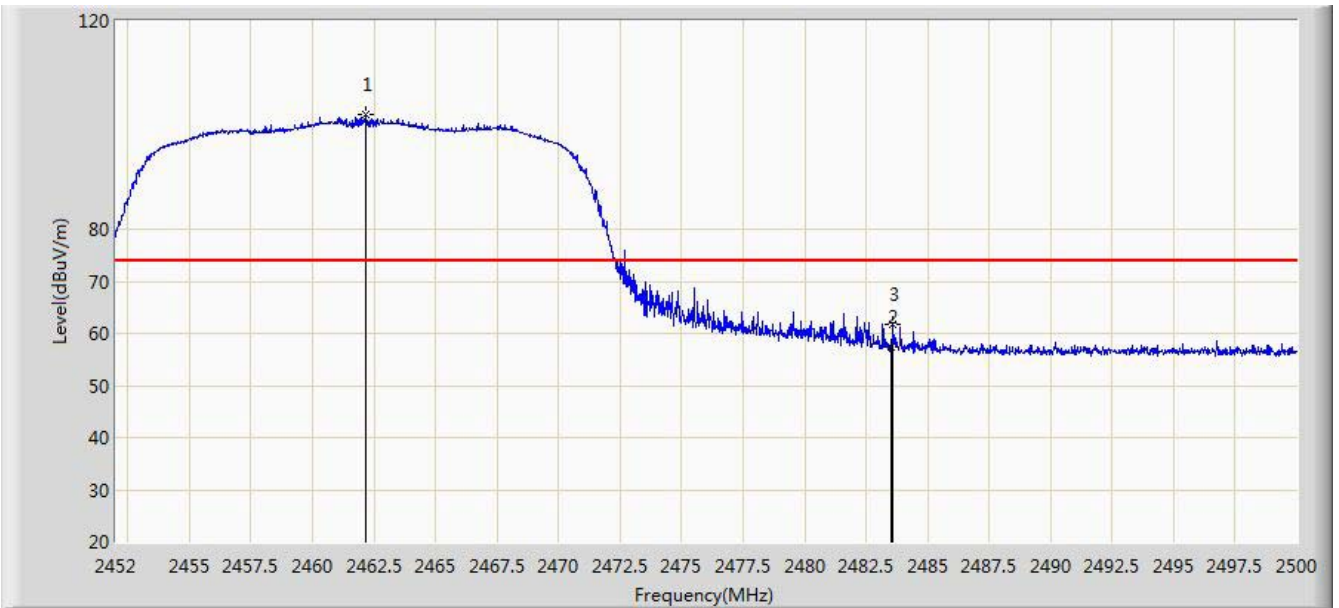

No	Flag	Mark	Frequency (MHz)	Measure Level (dBuV/m)	Reading Level (dBuV)	Over Limit (dB)	Limit (dBuV/m)	Factor (dB)	Type
1		*	2462.176	101.932	71.320	N/A	N/A	30.612	PK
2			2483.500	57.395	26.722	-16.605	74.000	30.673	PK
3			2483.584	61.750	31.077	-12.250	74.000	30.673	PK

Note: Measure Level (dBuV/m) = Reading Level (dBuV) + Factor (dB)

Factor (dB) = Cable Loss (dB) + Antenna Factor (dB/m)

Engineer: Roy Cheng	
Site: AC1	Time: 2014/10/22 - 17:31
Limit: FCC_Part15.209_RE(3m)	Margin: 0
Probe: BBHA9120D_1-18GHz	Polarity: Vertical
EUT: Tablet PC	Power: AC 120V/60Hz
<b>Worst Test Mode:</b> Transmit at channel 2412MHz by 802.1120	



No	Flag	Mark	Frequency (MHz)	Measure Level (dBuV/m)	Reading Level (dBuV)	Over Limit (dB)	Limit (dBuV/m)	Factor (dB)	Type
1		*	2461.000	89.500	58.890	N/A	N/A	30.609	AV
2			2483.500	44.755	14.082	-9.245	54.000	30.673	AV

Note: Measure Level (dBμV/m) = Reading Level (dBμV) + Factor (dB)

Factor (dB) = Cable Loss (dB) + Antenna Factor (dB/m)

Engineer: Roy Cheng	
Site: AC1	Time: 2014/10/22 - 18:36
Limit: FCC_Part15.209_RE(3m)	Margin: 0
Probe: BBHA9120D_1-18GHz	Polarity: Horizontal
EUT: Tablet PC	Power: AC 120V/60Hz
Test Mode : Transmit at channel 2402MHz by BLE	

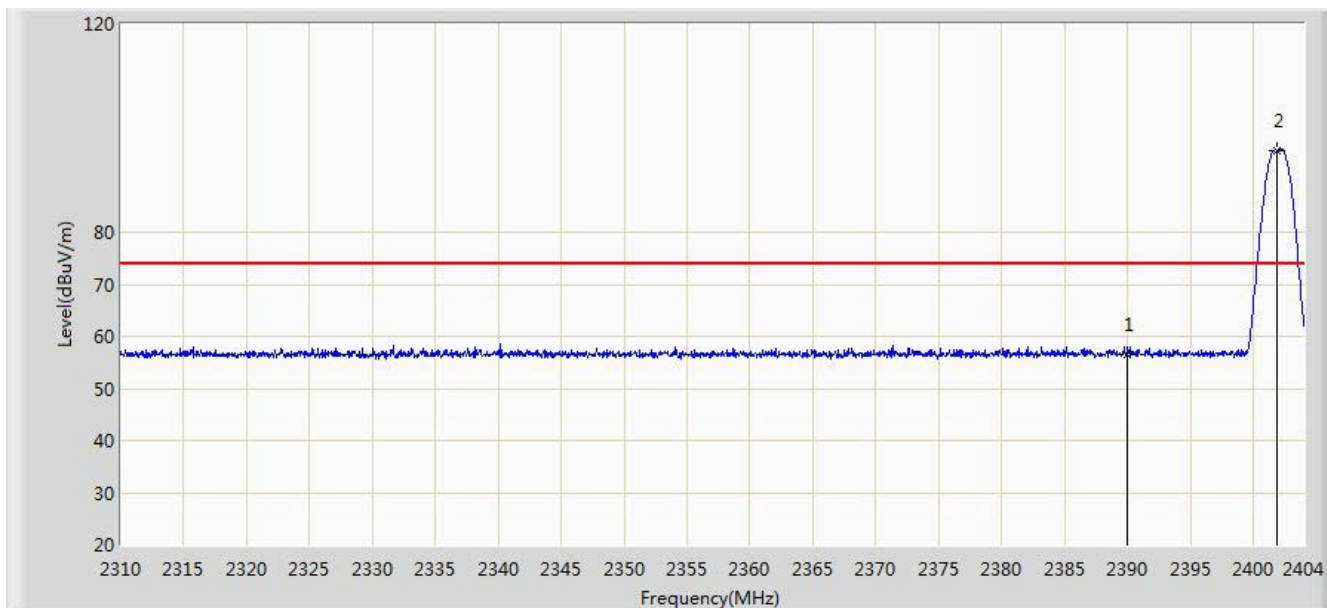

No	Flag	Mark	Frequency (MHz)	Measure Level (dBuV/m)	Reading Level (dBuV)	Over Limit (dB)	Limit (dBuV/m)	Factor (dB)	Type
1			2390.000	56.421	25.737	-17.579	74.000	30.684	PK
2		*	2401.885	95.727	65.066	N/A	N/A	30.661	PK

Note: Measure Level (dB $\mu$ V/m) = Reading Level (dB $\mu$ V) + Factor (dB)

Factor (dB) = Cable Loss (dB) + Antenna Factor (dB/m)

Engineer: Roy Cheng	
Site: AC1	Time: 2014/10/22 - 18:41
Limit: FCC_Part15.209_RE(3m)	Margin: 0
Probe: BBHA9120D_1-18GHz	Polarity: Horizontal
EUT: Tablet PC	Power: AC 120V/60Hz
Test Mode : Transmit at channel 2402MHz by BLE	

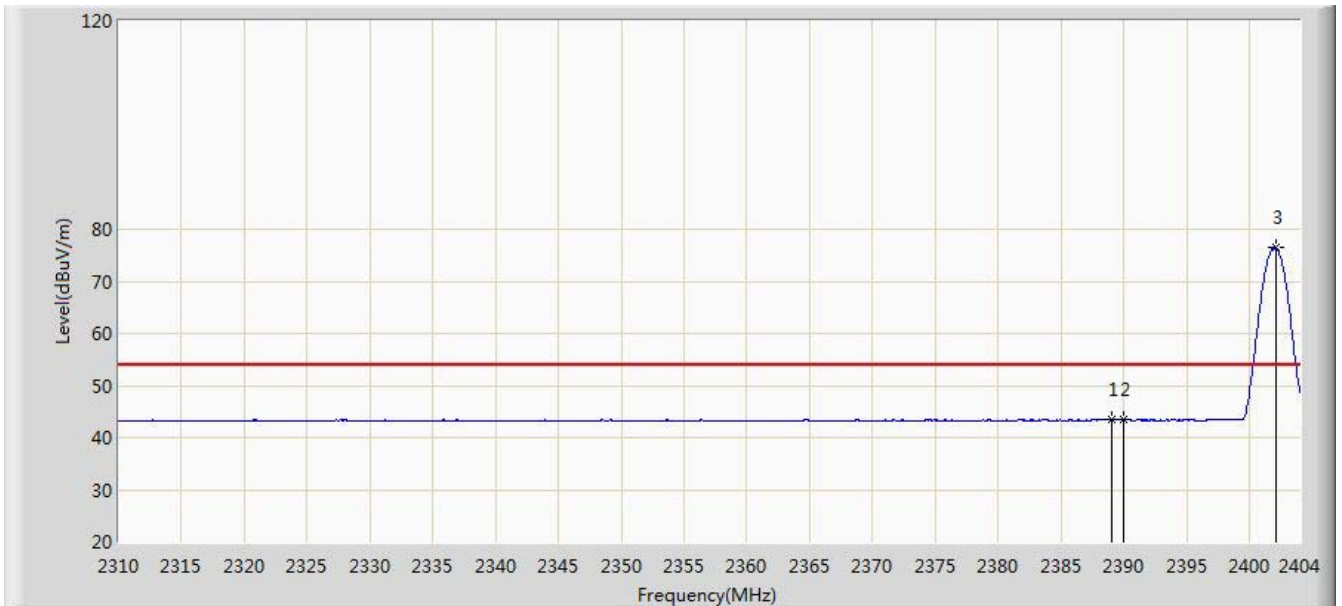

No	Flag	Mark	Frequency (MHz)	Measure Level (dBuV/m)	Reading Level (dBuV)	Over Limit (dB)	Limit (dBuV/m)	Factor (dB)	Type
1			2389.054	43.562	12.876	-10.438	54.000	30.686	AV
2			2390.000	43.350	12.666	-10.650	54.000	30.684	AV
3		*	2402.073	76.427	45.766	N/A	N/A	30.661	AV

Note: Measure Level (dB $\mu$ V/m) = Reading Level (dB $\mu$ V) + Factor (dB)

Factor (dB) = Cable Loss (dB) + Antenna Factor (dB/m)

Engineer: Roy Cheng	
Site: AC1	Time: 2014/10/22 - 18:41
Limit: FCC_Part15.209_RE(3m)	Margin: 0
Probe: BBHA9120D_1-18GHz	Polarity: Vertical
EUT: Tablet PC	Power: AC 120V/60Hz
Test Mode : Transmit at channel 2402MHz by BLE	

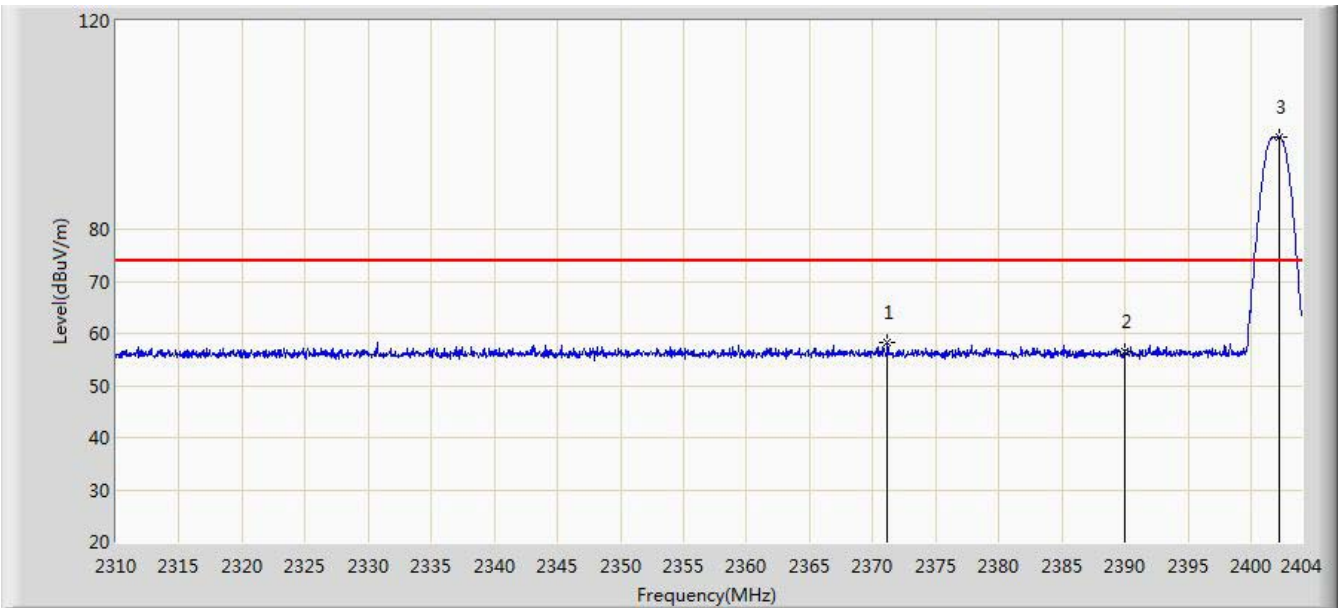

No	Flag	Mark	Frequency (MHz)	Measure Level (dBuV/m)	Reading Level (dBuV)	Over Limit (dB)	Limit (dBuV/m)	Factor (dB)	Type
1			2371.194	58.166	27.439	-15.834	74.000	30.727	PK
2			2390.000	56.495	25.811	-17.505	74.000	30.684	PK
3		*	2402.214	97.690	67.029	N/A	N/A	30.661	PK

Note: Measure Level (dBuV/m) = Reading Level (dBuV) + Factor (dB)

Factor (dB) = Cable Loss (dB) + Antenna Factor (dB/m)

Engineer: Roy Cheng	
Site: AC1	Time: 2014/10/22 - 18:43
Limit: FCC_Part15.209_RE(3m)	Margin: 0
Probe: BBHA9120D_1-18GHz	Polarity: Vertical
EUT: Tablet PC	Power: AC 120V/60Hz
Test Mode : Transmit at channel 2402MHz by BLE	

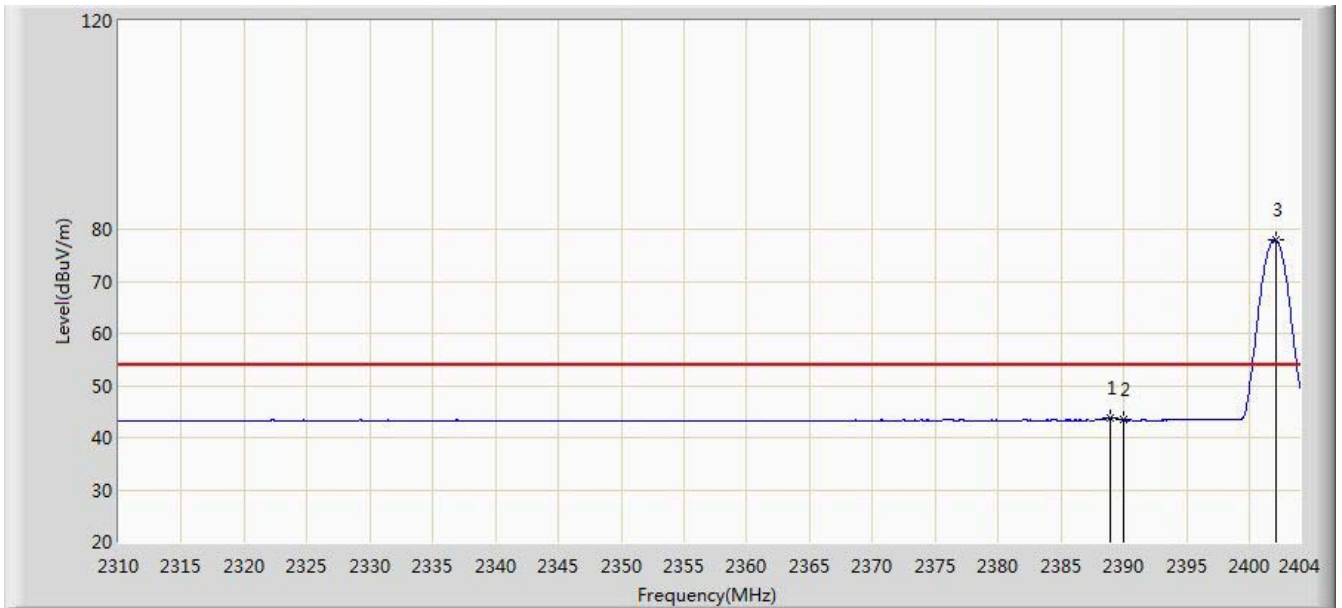

No	Flag	Mark	Frequency (MHz)	Measure Level (dBuV/m)	Reading Level (dBuV)	Over Limit (dB)	Limit (dBuV/m)	Factor (dB)	Type
1			2388.913	43.793	13.107	-10.207	54.000	30.687	AV
2			2390.000	43.436	12.752	-10.564	54.000	30.684	AV
3		*	2402.073	77.946	47.285	N/A	N/A	30.661	AV

Note: Measure Level (dBμV/m) = Reading Level (dBμV) + Factor (dB)

Factor (dB) = Cable Loss (dB) + Antenna Factor (dB/m)

Engineer: Roy Cheng	
Site: AC1	Time: 2014/10/22 - 18:44
Limit: FCC_Part15.209_RE(3m)	Margin: 0
Probe: BBHA9120D_1-18GHz	Polarity: Horizontal
EUT: Tablet PC	Power: AC 120V/60Hz
Test Mode : Transmit at channel 2480MHz by BLE	

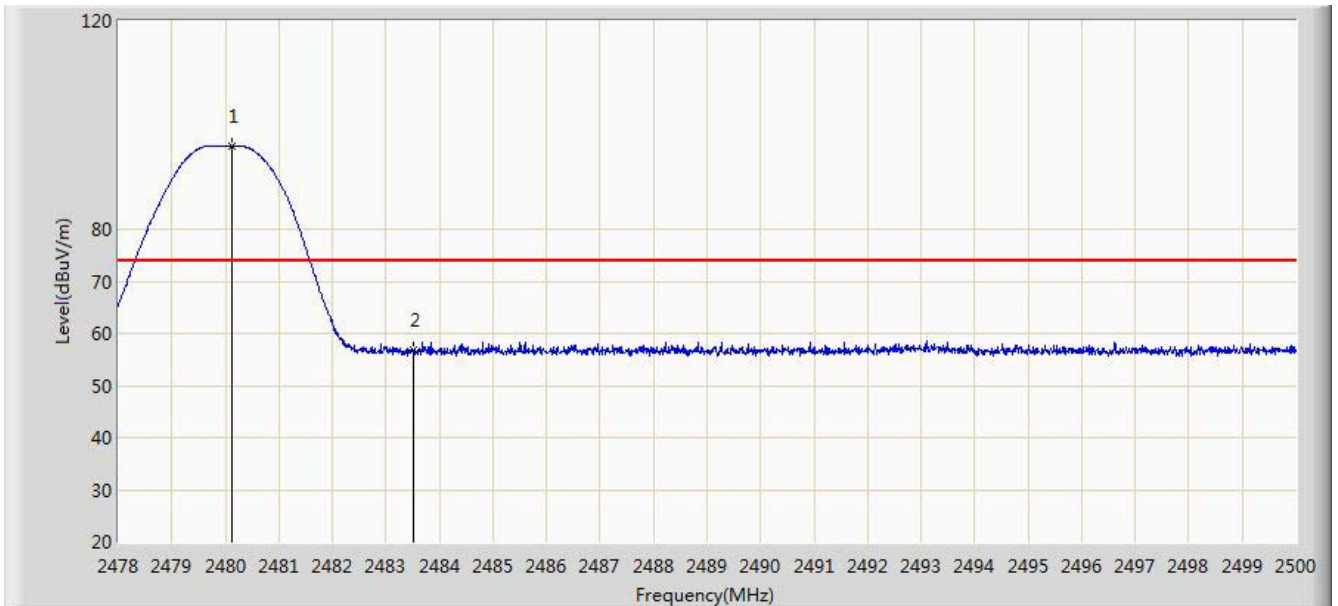

No	Flag	Mark	Frequency (MHz)	Measure Level (dBuV/m)	Reading Level (dBuV)	Over Limit (dB)	Limit (dBuV/m)	Factor (dB)	Type
1		*	2480.112	96.010	65.347	N/A	N/A	30.662	PK
2			2483.500	56.864	26.191	-17.136	74.000	30.673	PK

Note: Measure Level (dBμV/m) = Reading Level (dBμV) + Factor (dB)

Factor (dB) = Cable Loss (dB) + Antenna Factor (dB/m)

Engineer: Roy Cheng	
Site: AC1	Time: 2014/10/22 - 18:46
Limit: FCC_Part15.209_RE(3m)	Margin: 0
Probe: BBHA9120D_1-18GHz	Polarity: Horizontal
EUT: Tablet PC	Power: AC 120V/60Hz
Test Mode : Transmit at channel 2480MHz by BLE	

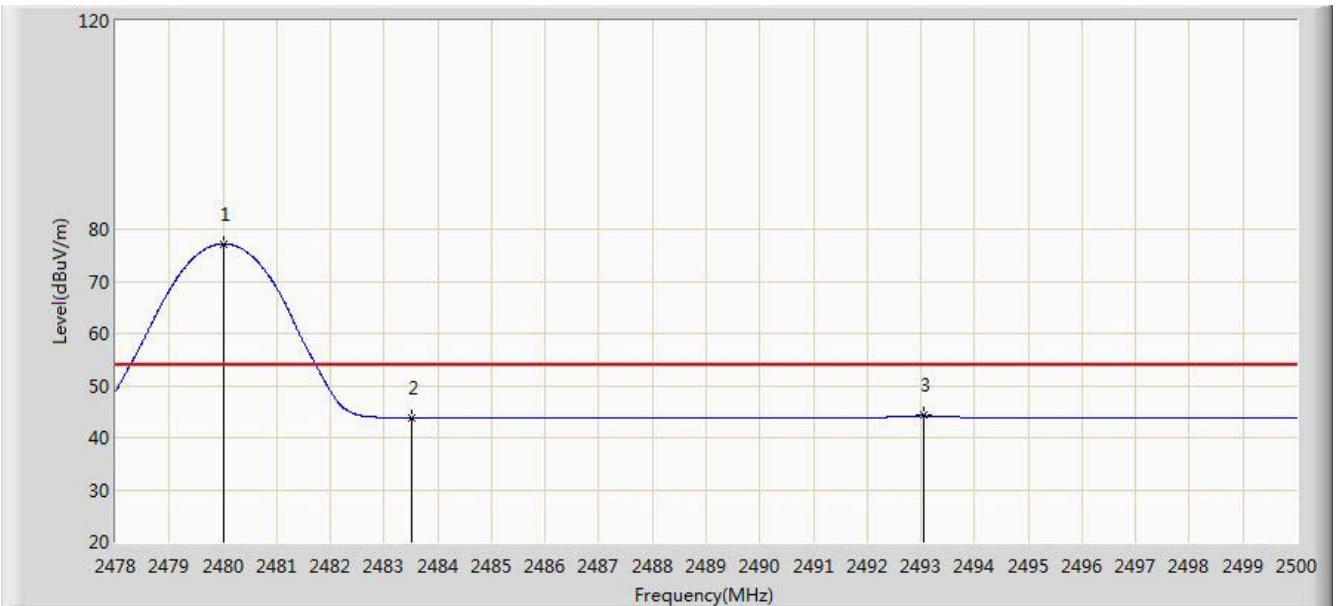

No	Flag	Mark	Frequency (MHz)	Measure Level (dBuV/m)	Reading Level (dBuV)	Over Limit (dB)	Limit (dBuV/m)	Factor (dB)	Type
1		*	2480.002	77.194	46.532	N/A	N/A	30.662	AV
2			2483.500	43.758	13.085	-10.242	54.000	30.673	AV
3			2493.048	44.213	13.512	-9.787	54.000	30.701	AV

Note: Measure Level (dB $\mu$ V/m) = Reading Level (dB $\mu$ V) + Factor (dB)

Factor (dB) = Cable Loss (dB) + Antenna Factor (dB/m)



Engineer: Roy Cheng	
Site: AC1	Time: 2014/10/22 - 18:46
Limit: FCC_Part15.209_RE(3m)	Margin: 0
Probe: BBHA9120D_1-18GHz	Polarity: Vertical
EUT: Tablet PC	Power: AC 120V/60Hz
Test Mode : Transmit at channel 2480MHz by BLE	

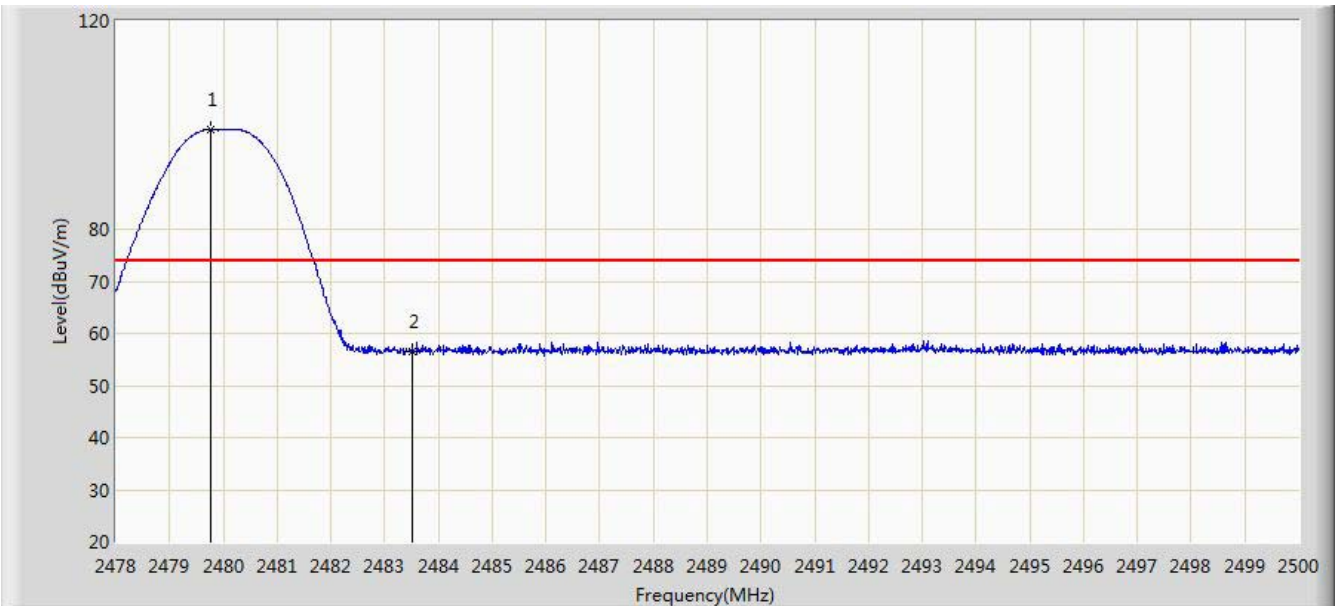

No	Flag	Mark	Frequency (MHz)	Measure Level (dBuV/m)	Reading Level (dBuV)	Over Limit (dB)	Limit (dBuV/m)	Factor (dB)	Type
1		*	2479.771	99.132	68.470	N/A	N/A	30.662	PK
2			2483.500	56.496	25.823	-17.504	74.000	30.673	PK

Note: Measure Level (dBμV/m) = Reading Level (dBμV) + Factor (dB)

Factor (dB) = Cable Loss (dB) + Antenna Factor (dB/m)

Engineer: Roy Cheng	
Site: AC1	Time: 2014/10/22 - 18:48
Limit: FCC_Part15.209_RE(3m)	Margin: 0
Probe: BBHA9120D_1-18GHz	Polarity: Vertical
EUT: Tablet PC	Power: AC 120V/60Hz
Test Mode : Transmit at channel 2480MHz by BLE	

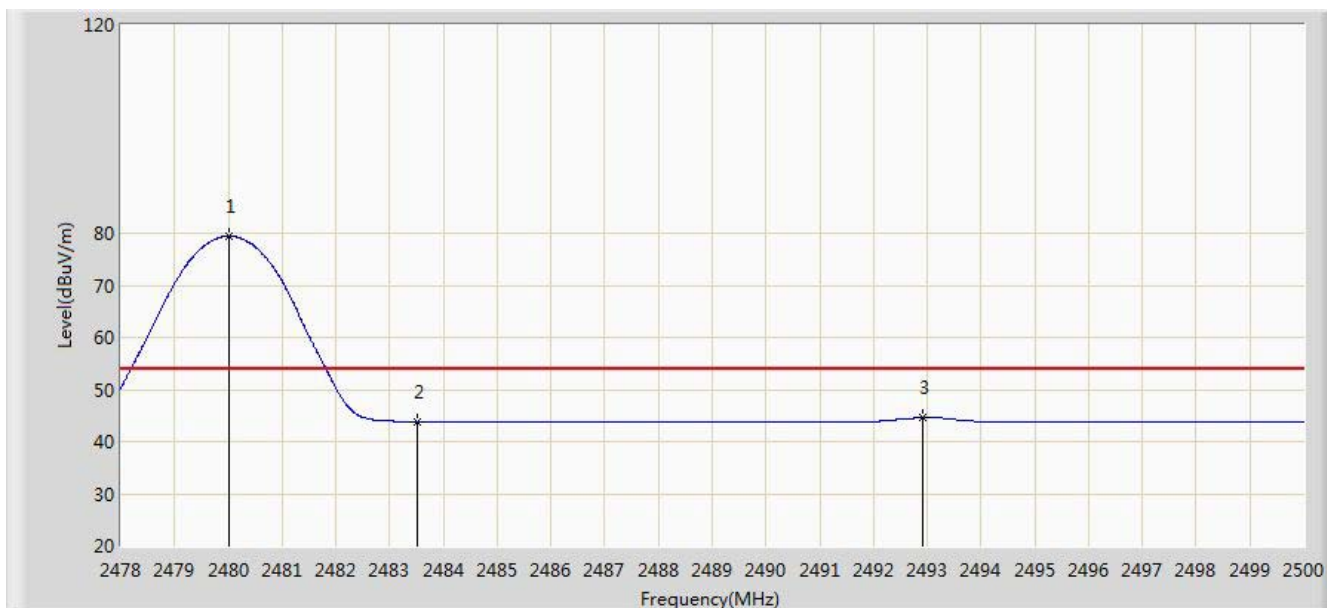

No	Flag	Mark	Frequency (MHz)	Measure Level (dBuV/m)	Reading Level (dBuV)	Over Limit (dB)	Limit (dBuV/m)	Factor (dB)	Type
1		*	2480.002	79.421	48.759	N/A	N/A	30.662	AV
2			2483.500	43.782	13.109	-10.218	54.000	30.673	AV
3			2492.905	44.558	13.858	-9.442	54.000	30.701	AV

Note: Measure Level (dB $\mu$ V/m) = Reading Level (dB $\mu$ V) + Factor (dB)

Factor (dB) = Cable Loss (dB) + Antenna Factor (dB/m)

## 7.8. AC Conducted Emissions Measurement

### 7.8.1. Test Limit

FCC Part 15 Subpart C Paragraph 15.207 Limits		
Frequency (MHz)	QP (dBuV)	AV (dBuV)
0.15 - 0.50	66 - 56	56 - 46
0.50 - 5.0	56	46
5.0 - 30	60	50

Note 1: The lower limit shall apply at the transition frequencies.

Note 2: The limit decreases linearly with the logarithm of the frequency in the range 0.15MHz to 0.5MHz.

### 7.8.2. Test Setup

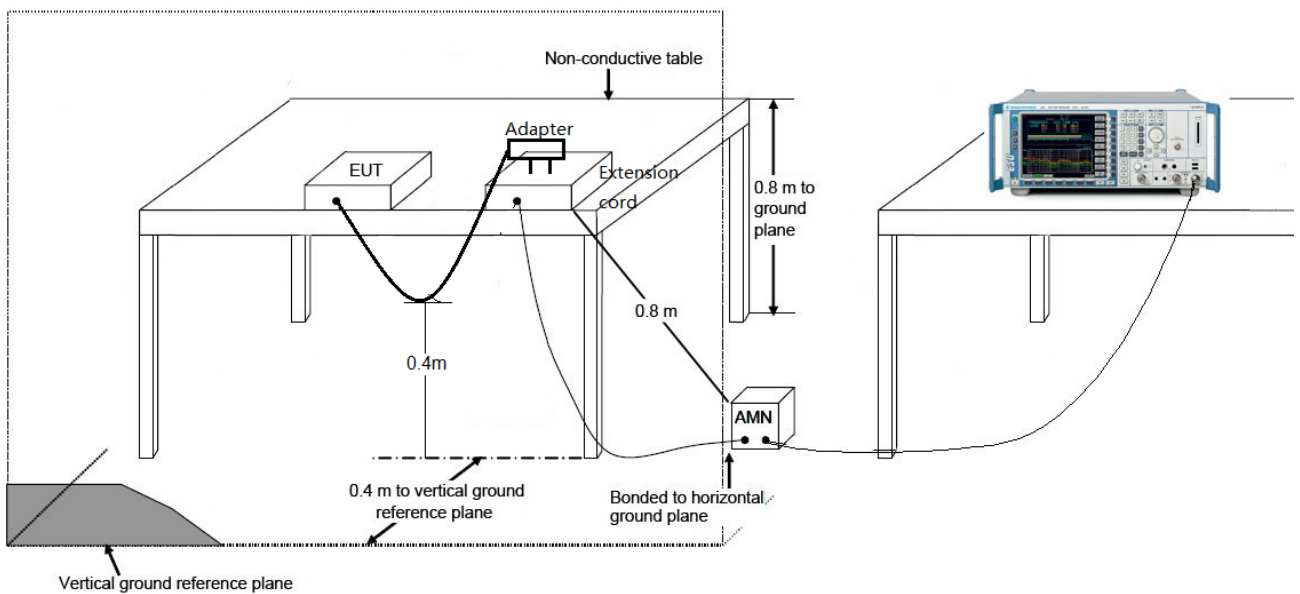

### 7.8.3. Test Result

Engineer: Roy Cheng	
Site: SR2	Time: 2014/10/23 - 16:54
Limit: FCC_Part15.207_CE_AC Power	Margin: 0
Probe: ENV216_101683_Filter On	Polarity: Line
EUT: Tablet PC	Power: AC 120V/60Hz
Note: Normal Operation	

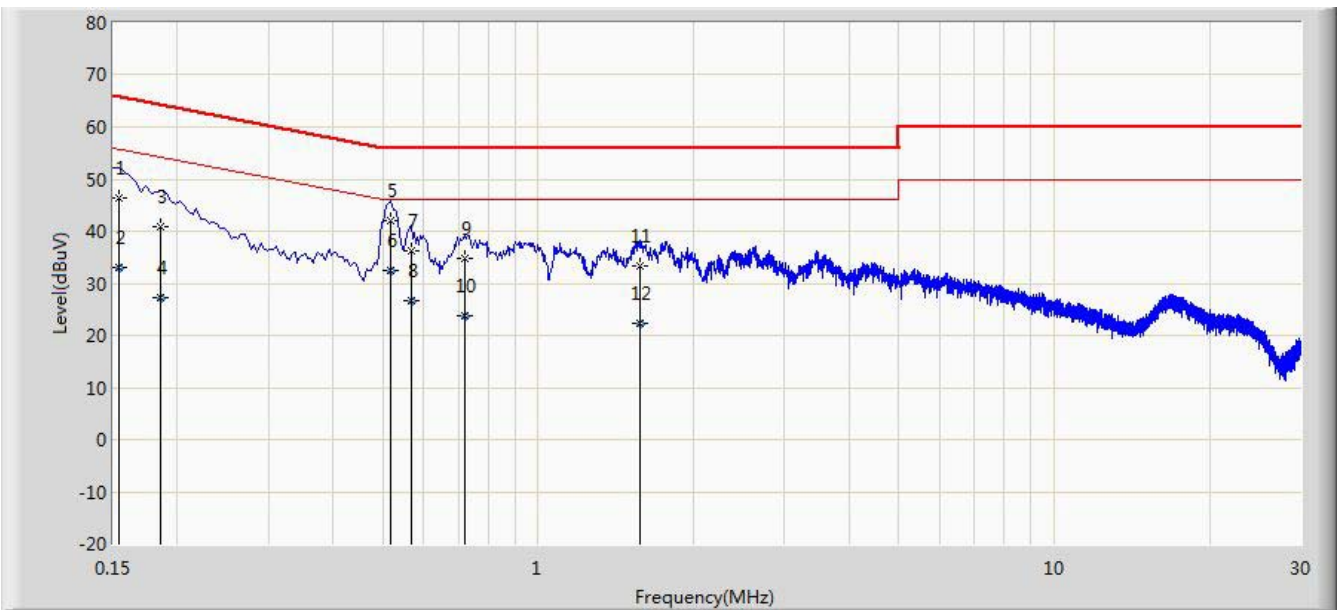

No	Flag	Mark	Frequency (MHz)	Measure Level (dBuV)	Reading Level (dBuV)	Over Limit (dB)	Limit (dBuV)	Factor (dB)	Type
1			0.154	46.289	35.550	-19.492	65.781	10.740	QP
2			0.154	32.941	22.201	-22.840	55.781	10.740	AV
3			0.186	41.002	30.963	-23.212	64.213	10.039	QP
4			0.186	27.350	17.312	-26.863	54.213	10.039	AV
5			0.518	42.140	31.983	-13.860	56.000	10.156	QP
6		*	0.518	32.497	22.340	-13.503	46.000	10.156	AV
7			0.566	36.229	26.097	-19.771	56.000	10.132	QP
8			0.566	26.721	16.588	-19.279	46.000	10.132	AV
9			0.722	34.758	24.706	-21.242	56.000	10.052	QP
10			0.722	23.904	13.852	-22.096	46.000	10.052	AV
11			1.570	33.248	23.362	-22.752	56.000	9.886	QP
12			1.570	22.228	12.342	-23.772	46.000	9.886	AV

Note: Measure Level (dBμV) = Reading Level (dBμV) + Factor (dB)

Factor (dB) = Cable Loss (dB) + LISN Factor (dB)

Engineer: Roy Cheng	
Site: SR2	Time: 2014/10/23 - 17:01
Limit: FCC_Part15.207_CE_AC Power	Margin: 0
Probe: ENV216_101683_Filter On	Polarity: Neutral
EUT: Tablet PC	Power: AC 120V/60Hz
Note: Normal Operation	

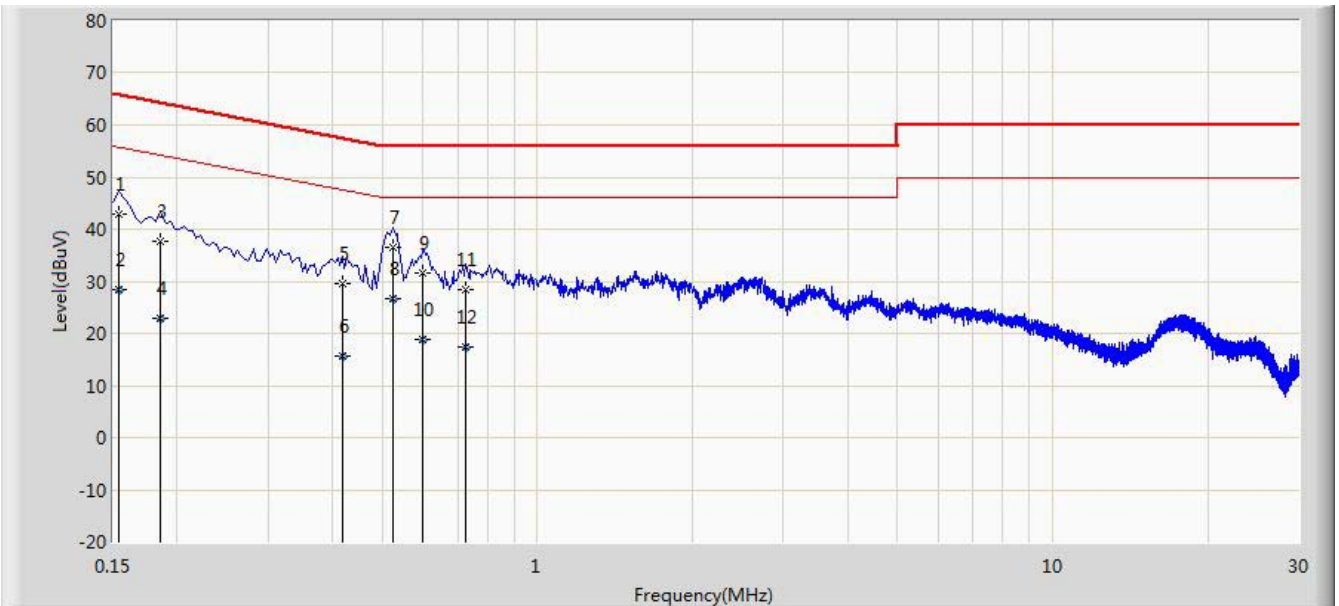

No	Flag	Mark	Frequency (MHz)	Measure Level (dBuV)	Reading Level (dBuV)	Over Limit (dB)	Limit (dBuV)	Factor (dB)	Type
1			0.154	42.853	32.138	-22.928	65.781	10.716	QP
2			0.154	28.329	17.613	-27.452	55.781	10.716	AV
3			0.186	37.740	27.705	-26.473	64.213	10.035	QP
4			0.186	22.898	12.863	-31.315	54.213	10.035	AV
5			0.418	29.539	19.413	-27.948	57.488	10.126	QP
6			0.418	15.718	5.592	-31.770	47.488	10.126	AV
7		*	0.526	36.571	26.399	-19.429	56.000	10.172	QP
8			0.526	26.562	16.391	-19.438	46.000	10.172	AV
9			0.598	31.463	21.331	-24.537	56.000	10.132	QP
10			0.598	18.820	8.688	-27.180	46.000	10.132	AV
11			0.726	28.482	18.422	-27.518	56.000	10.060	QP
12			0.726	17.517	7.457	-28.483	46.000	10.060	AV

Note: Measure Level (dBμV) = Reading Level (dBμV) + Factor (dB)

Factor (dB) = Cable Loss (dB) + LISN Factor (dB)

## 8. CONCLUSION

The data collected relate only the item(s) tested and show that the **Tablet PC FCC ID: 2AAP6E7232** is in compliance with Part 15C of the FCC Rules.