



FCC RADIO TEST REPORT

FCC ID:2AAOV-INDI

Product : Tablet PC

Trade Mark : Tobii Dynavox

Model Name : Indi

Serial Model : N/A

Report No. : NTEK-2016NT12280982F5

Prepared for

Tobii Dynavox LLC

2100 Wharton Street, Suite 400 , Pittsburgh, PA 15203, USA

Prepared by

NTEK Testing Technology Co., Ltd.

1/F, Building E, Fenda Science Park, Sanwei Community,
Xixiang Street Bao'an District, Shenzhen 518126 P.R. China

Tel.: +86-755-6115 6588

Fax.: +86-755-6115 6599

Website: <http://www.ntek.org.cn>

TEST RESULT CERTIFICATION

Applicant's name : Tobii Dynavox LLC
Address : 2100 Wharton Street,Suite 400 , Pittsburgh,PA 15203,USA
Manufacturer's Name : Tobii Dynavox LLC
Address : 2100 Wharton Street,Suite 400 , Pittsburgh,PA 15203,USA

Product description

Product name..... : Tablet PC
Model and/or type reference : Indi
Serial Model : N/A

Standards : FCC Part15.407: 01 Oct. 2015

Test procedure..... ANSI C63.10-2013 and KDB 789033 D02 General UNII Test Procedures New Rules v01r01
FCC KDB 662911 D01 Multiple Transmitter Output v01
FCC KDB 662911 D02 MIMO With Cross Polarized Antenna V01

This device described above has been tested by NTEK, and the test results show that the equipment under test (EUT) is in compliance with the FCC requirements/ the Industry Canada requirements.. And it is applicable only to the tested sample identified in the report.

This report shall not be reproduced except in full, without the written approval of NTEK, this document may be altered or revised by NTEK, personnel only, and shall be noted in the revision of the document.

Date of Test

Date (s) of performance of tests..... 28 Dec. 2016 ~14 Mar. 2017

Date of Issue..... 14 Mar. 2017

Test Result..... **Pass**

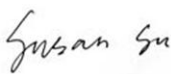
Testing Engineer : 
(Susan Su)

Technical Manager : 
(Jason Chen)

Authorized Signatory : 
(Sam Chen)

Table of Contents

	Page
1 . SUMMARY OF TEST RESULTS	5
1.1 TEST FACILITY	6
1.2 MEASUREMENT UNCERTAINTY	6
2 . GENERAL INFORMATION	7
2.1 GENERAL DESCRIPTION OF EUT	7
2.2 DESCRIPTION OF TEST MODES	10
2.3 BLOCK DIGRAM SHOWING THE CONFIGURATION OF SYSTEM TESTED	11
2.4 DESCRIPTION OF SUPPORT UNITS(CONDUCTED MODE)	12
2.5 EQUIPMENTS LIST FOR ALL TEST ITEMS	13
3 . EMC EMISSION TEST	15
3.1 CONDUCTED EMISSION MEASUREMENT	15
3.1.1 POWER LINE CONDUCTED EMISSION LIMITS	15
3.1.2 TEST PROCEDURE	16
3.1.3 DEVIATION FROM TEST STANDARD	16
3.1.4 TEST SETUP	16
3.1.5 EUT OPERATING CONDITIONS	16
3.1.6 TEST RESULTS	17
3.2 RADIATED EMISSION MEASUREMENT	21
3.2.1 APPLICABLE STANDARD	21
3.2.2 CONFORMANCE LIMIT	21
3.2.3 MEASURING INSTRUMENTS	21
3.2.4 TEST CONFIGURATION	21
3.2.5 TEST PROCEDURE	23
3.2.6 TEST RESULTS (BETWEEN 9KHZ – 30 MHZ)	24
3.2.7 TEST RESULTS (BETWEEN 30MHZ – 1GHZ)	25
3.2.8 TEST RESULTS (1GHZ-18GHZ)	29
4 . POWER SPECTRAL DENSITY TEST	37
4.1 APPLIED PROCEDURES / LIMIT	37
4.2 TEST PROCEDURE	38
4.3 DEVIATION FROM STANDARD	38
4.4 TEST SETUP	38
4.5 EUT OPERATION CONDITIONS	38
4.6 TEST RESULTS	39
5 . 26 DB & 99% EMISSION BANDWIDTH	45
5.1 APPLIED PROCEDURES / LIMIT	45
5.2 TEST PROCEDURE	45

Table of Contents

	Page
5.3 EUT OPERATION CONDITIONS	46
5.4 TEST RESULTS	47
6 . MINIMUM 6 DB BANDWIDTH	53
6.1 APPLIED PROCEDURES / LIMIT	53
6.2 TEST PROCEDURE	53
6.3 DEVIATION FROM STANDARD	53
6.4 TEST SETUP	53
6.5 EUT OPERATION CONDITIONS	53
6.6 TEST RESULTS	54
7 . MAXIMUM CONDUCTED OUTPUT POWER	60
7.1 PPLIED PROCEDURES / LIMIT	60
7.2 TEST PROCEDURE	60
7.3 DEVIATION FROM STANDARD	62
7.4 TEST SETUP	62
7.5 EUT OPERATION CONDITIONS	62
7.6 TEST RESULTS	63
8 . OUT OF BAND EMISSIONS	65
8.1 APPLICABLE STANDARD	65
8.2 TEST PROCEDURE	65
8.3 DEVIATION FROM STANDARD	65
8.4 TEST SETUP	65
8.5 EUT OPERATION CONDITIONS	65
8.6 TEST RESULTS	66
9.SPURIOUS RF CONDUCTED EMISSIONS	70
9.1CONFORMANCE LIMIT	70
9.2MEASURING INSTRUMENTS	70
9.3TEST SETUP	70
9.4TEST PROCEDURE	70
9.5TEST RESULTS	70
10. ANTENNA REQUIREMENT	79
10.1 STANDARD REQUIREMENT	79
10.2 EUT ANTENNA	79
APPENDIX-PHOTOGRAPHS OF EUT CONSTRUCTIONAL DETAILS	

1. SUMMARY OF TEST RESULTS

Test procedures according to the technical standards:

FCC Part15 (15.407) , Subpart E			
Standard Section	Test Item	Judgment	Remark
15.207	AC Power Line Conducted Emissions	PASS	
15.209(a), 15.407 (b)(1) 15.407 (b)(4) 15.407 (b)(6)	Spurious Radiated Emissions	PASS	
15.407 (a)(1) 15.407 (a)(3) 15.1049	26 dB and 99% Emission Bandwidth	PASS	
15.407(e)	Minimum 6 dB bandwidth	PASS	
15.407 (a)(1) 15.407 (a)(3)	Maximum Conducted Output Power	PASS	
2.1051, 15.407(b)(1) 15.407(b)(4)	Band Edges	PASS	
15.407 (a)(1) 15.407 (a)(3)	Power Spectral Density	PASS	
2.1051, 15.407(b)	Spurious Emissions at Antenna Terminals	PASS	
15.203	Antenna Requirement	PASS	

NOTE:

(1) "N/A" denotes test is not applicable in this Test Report

1.1 TEST FACILITY

NTEK Testing Technology Co., Ltd

Add.:1/F, Building E, Fenda Science Park, Sanwei Community, Xixiang Street, Bao'an District, Shenzhen P.R. China.

FCC Registration No.:238937; IC Registration No.:9270A-1

CNAS Registration No.:L5516

1.2 MEASUREMENT UNCERTAINTY

The reported uncertainty of measurement $y \pm U$, where expanded uncertainty U is based on a standard uncertainty multiplied by a coverage factor of $k=2$, providing a level of confidence of approximately **95 %**.

No.	Item	Uncertainty
1	Conducted Emission Test	$\pm 1.38\text{dB}$
2	RF power,conducted	$\pm 0.16\text{dB}$
3	Spurious emissions,conducted	$\pm 0.21\text{dB}$
4	All emissions,radiated(<1G)	$\pm 4.68\text{dB}$
5	All emissions,radiated(>1G)	$\pm 4.89\text{dB}$
6	Temperature	$\pm 0.5^\circ\text{C}$
7	Humidity	$\pm 2\%$

2. GENERAL INFORMATION

2.1 GENERAL DESCRIPTION OF EUT

Equipment	Tablet PC		
Trade Mark	Tobii Dynavox		
Model Name	Indi		
Product Description	IEEE 802.11 WLAN Mode Supported	<input checked="" type="checkbox"/> 802.11a(20MHz channel bandwidth) <input checked="" type="checkbox"/> 802.11n (20MHz channel bandwidth) <input checked="" type="checkbox"/> 802.11n(40MHz channel bandwidth) <input type="checkbox"/> 802.11AC(80MHz channel bandwidth)	
	Data Rate	802.11 a: 6,9,12,18,24,36,48,54Mbps; 802.11n(HT20):MCS0-MCS15; 802.11n(HT40):MCS0-MCS15;	
	Modulation	OFDM with BPSK/QPSK/16QAM/64QAM/256QAM for 802.11a/n;	
	Operating Frequency Range	<input checked="" type="checkbox"/> 5180-5240MHz for 802.11a/n(HT20); 5190-5230MHz for 802.11n(HT40); 5210MHz for 802.11 AC80; <input checked="" type="checkbox"/> 5745-5825 MHz for 802.11a/n(HT20); 5755-5795 MHz for 802.11a/n(HT40);	
	Number of Channels	<input checked="" type="checkbox"/> 4 channels for 802.11a/N20 in the 5180-5240MHz band ; 2 channels for 802.11 N40 in the 5190-5230MHz band ; <input checked="" type="checkbox"/> 5 channels for 802.11a/N20 in the 5745-5825MHz band ; 2 channels for 802.11 N40 in the 5755-5795MHz band ;	
	Antenna Type	FPCB Antenna	
	Smart system	<input checked="" type="checkbox"/> SISO for 802.11a <input checked="" type="checkbox"/> SISO for 802.11n	
	Antenna Gain	See Table for FPCB Antenna	
	Based on the application, features, or specification exhibited in User's Manual, More details of EUT technical specification, please refer to the User's Manual.		
	Ratings	DC 7.4V from battery or DC 12V from adapter	
Adapter	Model:FJ-SW1202000N Output:DC 12V,2000mA Input:AC 100-240V 50/60Hz 0.6A Max		
Battery	DC 7.4V		
Connecting I/O Port(s)	Please refer to the User's Manual		
HW Version	EM_Human10_V2.0		
SW Version	EN_Pro_14393.726		

Note:

1. For a more detailed features description, please refer to the manufacturer's specifications or the User's Manual.
2. Frequency and Channel list for 802.11 a/n (20MHz) (5180-5240MHz):

Channel	Frequency (MHz)
36	5180
40	5200
44	5220
48	5240

Frequency and Channel list for 802.11 n /ac (40MHz) (5190-5230MHz):

Channel	Frequency (MHz)
38	5190
46	5230

Frequency and Channel list for 802.11 a/n(20 MHz) (5745-5825MHz):

Channel	Frequency (MHz)
149	5745
153	5765
157	5785
161	5805
165	5825

Frequency and Channel list for 802.11n (40MHz) (5755-5795MHz):

Channel	Frequency (MHz)
151	5755
159	5795

The EUT has two types of antenna.

Tx Antenna

Antenna	Antenna Type	Antenna Gain(dBi)	
		2.4G	5.0G
A(main)	FPCB	1	1

2.2 DESCRIPTION OF TEST MODES

To investigate the maximum EMI emission characteristics generates from EUT, the test system was pre-scanning tested base on the consideration of following EUT operation mode or test configuration mode which possible have effect on EMI emission level. Each of these EUT operation mode(s) or test configuration mode(s) mentioned above was evaluated respectively.

Pretest Mode	Description
Mode 1	Link Mode
Mode 2	802.11a / n20 CH36/ CH40/ CH 48 802.11a /n20 CH149/ CH157/ CH 165
Mode 3	802.11n40 CH38/ CH 46 802.11n40 CH 151 / CH 159

For Radiated Emission	
Final Test Mode	Description
Mode 1	Link Mode
Mode 2	802.11a / n20 CH36/ CH40/ CH 48 802.11a /n20 CH149/ CH157/ CH 165
Mode 3	802.11n40 CH38/ CH 46 802.11n40 CH 151 / CH 159

Note:

- (1) The measurements are performed at the highest, middle, lowest available channels.
- (2) The measurements are performed at all Bit Rate of Transmitter, the worst data was reported

2.3 BLOCK DIGRAM SHOWING THE CONFIGURATION OF SYSTEM TESTED

For AC Conducted Emission Mode

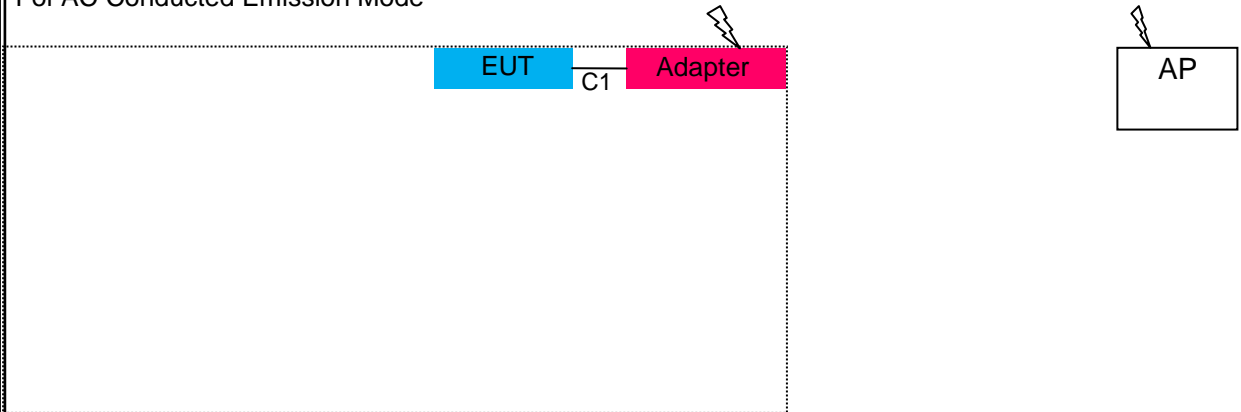

Radiated Spurious Emission Test

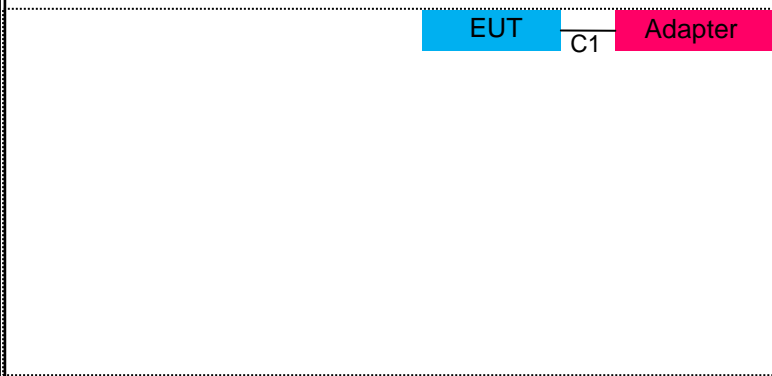

For Conducted Test Cases

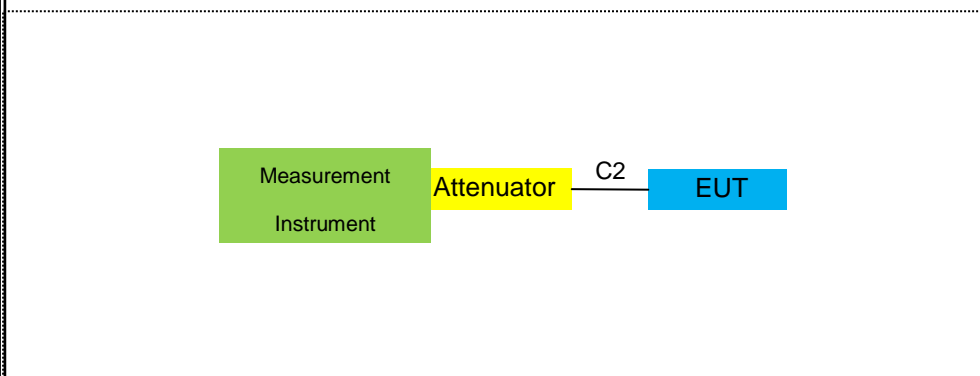

2.4 DESCRIPTION OF SUPPORT UNITS(CONDUCTED MODE)

The EUT has been tested as an independent unit together with other necessary accessories or support units. The following support units or accessories were used to form a representative test configuration during the tests.

Item	Equipment	Brand	Model/Type No.	Series No.	Note
E-1	Tablet PC	Tobii Dynavox	Indi	2AAOV-INDI	EUT
E-2	Adapter	N/A	FJ-SW1202000N	N/A	Peripherals

Item	Cable Type	Shielded Type	Ferrite Core	Length	Note
C-1	Power Cable	NO	NO	1.0m	
C-2	RF Cable	NO	NO	0.5m	

Note:

- (1) The support equipment was authorized by Declaration of Confirmation.
- (2) For detachable type I/O cable should be specified the length in cm in 『Length』 column.

2.5 EQUIPMENTS LIST FOR ALL TEST ITEMS

Radiation Test equipment

Item	Kind of Equipment	Manufacturer	Type No.	Serial No.	Last calibration	Calibrated until	Calibration period
1	Spectrum Analyzer	Agilent	E4407B	MY45108040	2016.07.06	2017.07.05	1 year
2	Spectrum Analyzer	Agilent	N9020A	MY49100060	2016.07.06	2017.07.05	1 year
3	EMI Test Receiver	Agilent	N9038A	MY53227146	2016.07.06	2017.07.05	1 year
4	Test Receiver	R&S	ESPI	101318	2016.07.06	2017.07.05	1 year
5	Bilog Antenna	TESEQ	CBL6111D	31216	2016.07.06	2017.07.05	1 year
6	50Ω Coaxial Switch	Anritsu	MP59B	6200264416	2016.07.06	2017.07.05	1 year
7	Spectrum Analyzer	ADVANTEST	R3132	150900201	2016.07.06	2017.07.05	1 year
8	Horn Antenna	EM	EM-AH-10180	2011071402	2016.07.06	2017.07.05	1 year
9	Horn Ant	Schwarzbeck	BBHA 9170	9170-181	2016.07.06	2017.07.05	1 year
10	Amplifier	EM	EM-30180	060538	2016.12.22	2017.12.21	1 year
11	Amplifier	MITEQ	TTA1840-35-HG	177156	2016.07.06	2017.07.05	1 year
12	Loop Antenna	ARA	PLA-1030/B	1029	2016.07.06	2017.07.05	1 year
13	Power Meter	R&S	NRVS	100696	2016.07.06	2017.07.05	1 year
14	Power Sensor	R&S	URV5-Z4	0395.1619.05	2016.07.06	2017.07.05	1 year
15	Test Cable	N/A	R-01	N/A	2016.07.06	2017.07.05	1 year
16	Test Cable	N/A	R-02	N/A	2016.07.06	2017.07.05	1 year
17	High Test Cable(1G-40 GHz)	N/A	R-03	N/A	2016.07.06	2017.07.05	1 year
18	High Test Cable(1G-40 GHz)	N/A	R-04	N/A	2016.07.06	2017.07.05	1 year

Conduction Test equipment

Item	Kind of Equipment	Manufacturer	Type No.	Serial No.	Last calibration	Calibrated until	Calibration period
1	Test Receiver	R&S	ESCI	101160	2016.07.06	2017.07.05	1 year
2	LISN	R&S	ENV216	101313	2016.08.24	2017.08.23	1 year
3	LISN	EMCO	3816/2	00042990	2016.07.06	2017.07.05	1 year
4	50Ω Coaxial Switch	Anritsu	MP59B	6200264417	2016.07.06	2017.07.05	1 year
5	Passive Voltage Probe	R&S	ESH2-Z3	100196	2016.07.06	2017.07.05	1 year
6	Absorbing clamp	R&S	MOS-21	100423	2016.07.06	2017.07.05	1 year
7	Test Cable	N/A	C01	N/A	2016.06.08	2017.06.07	1 year
8	Test Cable	N/A	C02	N/A	2016.06.08	2017.06.07	1 year
9	Test Cable	N/A	C03	N/A	2016.06.08	2017.06.07	1 year

1	Attenuation	MCE	24-10-34	BN9258	2016.07.06	2017.07.05	1 year
---	-------------	-----	----------	--------	------------	------------	--------

3. EMC EMISSION TEST

3.1 CONDUCTED EMISSION MEASUREMENT

3.1.1 POWER LINE CONDUCTED EMISSION Limits (Frequency Range 150KHz-30MHz)

FREQUENCY (MHz)	Class A (dBuV)		Class B (dBuV)		Standard
	Quasi-peak	Average	Quasi-peak	Average	
0.15 -0.5	79.00	66.00	66 - 56 *	56 - 46 *	CISPR
0.50 -5.0	73.00	60.00	56.00	46.00	CISPR
5.0 -30.0	73.00	60.00	60.00	50.00	CISPR

0.15 -0.5	79.00	66.00	66 - 56 *	56 - 46 *	FCC/ RSS-247
0.50 -5.0	73.00	60.00	56.00	46.00	FCC/ RSS-247
5.0 -30.0	73.00	60.00	60.00	50.00	FCC/ RSS-247

Note:

- (1) The tighter limit applies at the band edges.
- (2) The limit of " * " marked band means the limitation decreases linearly with the logarithm of the frequency in the range.

The following table is the setting of the receiver

Receiver Parameters	Setting
Attenuation	10 dB
Start Frequency	0.15 MHz
Stop Frequency	30 MHz
IF Bandwidth	9 kHz

3.1.2 TEST PROCEDURE

- a. The EUT was placed 0.8 meters from the horizontal ground plane with EUT being connected to the power mains through a line impedance stabilization network (LISN). All other support equipments powered from additional LISN(s). The LISN provide 50 Ohm/ 50uH of coupling impedance for the measuring instrument.
- b. Interconnecting cables that hang closer than 40 cm to the ground plane shall be folded back and forth in the center forming a bundle 30 to 40 cm long.
- c. I/O cables that are not connected to a peripheral shall be bundled in the center. The end of the cable may be terminated, if required, using the correct terminating impedance. The overall length shall not exceed 1 m.
- d. LISN at least 80 cm from nearest part of EUT chassis.
- e. For the actual test configuration, please refer to the related Item –EUT Test Photos.

3.1.3 DEVIATION FROM TEST STANDARD

No deviation

3.1.4 TEST SETUP

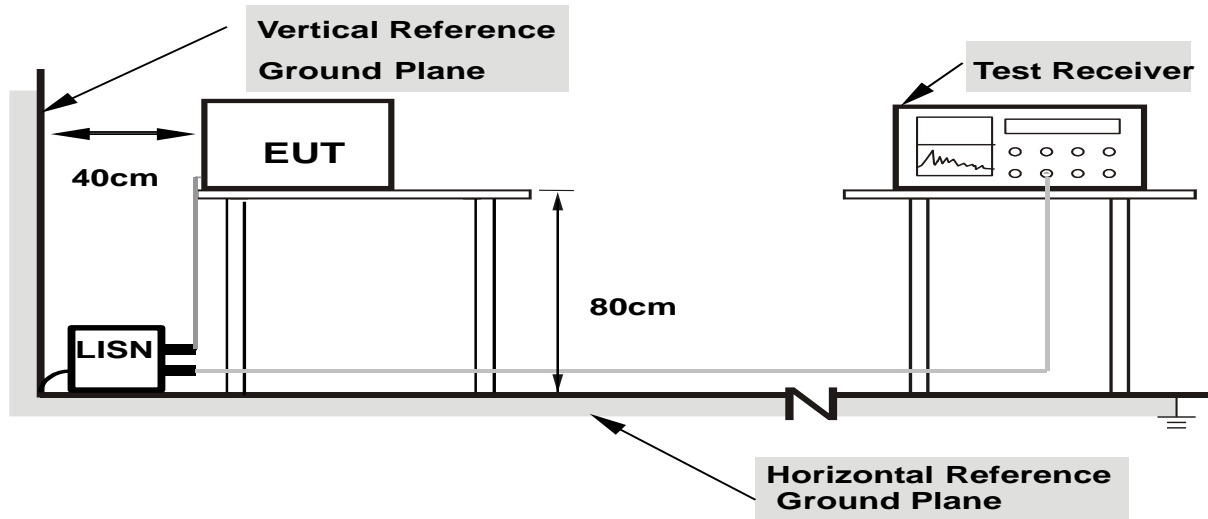

- Note:**
- 1. Support units were connected to second LISN.
 - 2. Both of LISNs (AMN) are 80 cm from EUT and at least 80 from other units and other metal planes

3.1.5 EUT OPERATING CONDITIONS

The EUT was configured for testing in a typical fashion (as a customer would normally use it). The EUT has been programmed to continuously transmit during test. This operating condition was tested and used to collect the included data.

3.1.6 TEST RESULTS

EUT :	Tablet PC	Model Name. :	Indi
Temperature :	26 °C	Relative Humidity :	56%
Pressure :	1010hPa	Phase :	L
Test Voltage :	DC 12V from adapter AC120V/60Hz	Test Mode :	Mode 1

Frequency (MHz)	Meter Reading (dBµV)	Factor (dB)	Emission Level (dBµV)	Limits (dBµV)	Margin (dB)	Detector Type
0.2953	38.28	10.12	48.4	60.37	-11.97	QP
0.2953	1.57	10.12	11.69	50.37	-38.68	AVG
0.442	36.4	9.9	46.3	57.02	-10.72	QP
0.442	6.38	9.9	16.28	47.02	-30.74	AVG
0.626	34.37	9.8	44.17	56	-11.83	QP
0.626	11.47	9.8	21.27	46	-24.73	AVG
0.9818	35.6	9.76	45.36	56	-10.64	QP
0.9818	11.98	9.76	21.74	46	-24.26	AVG
1.6694	35	9.76	44.76	56	-11.24	QP
1.6694	14.38	9.76	24.14	46	-21.86	AVG
3.474	35.23	9.77	45	56	-11	QP
3.474	14.08	9.77	23.85	46	-22.15	AVG

Remark:

1. All readings are Quasi-Peak and Average values.
2. Factor = Insertion Loss + Cable Loss.

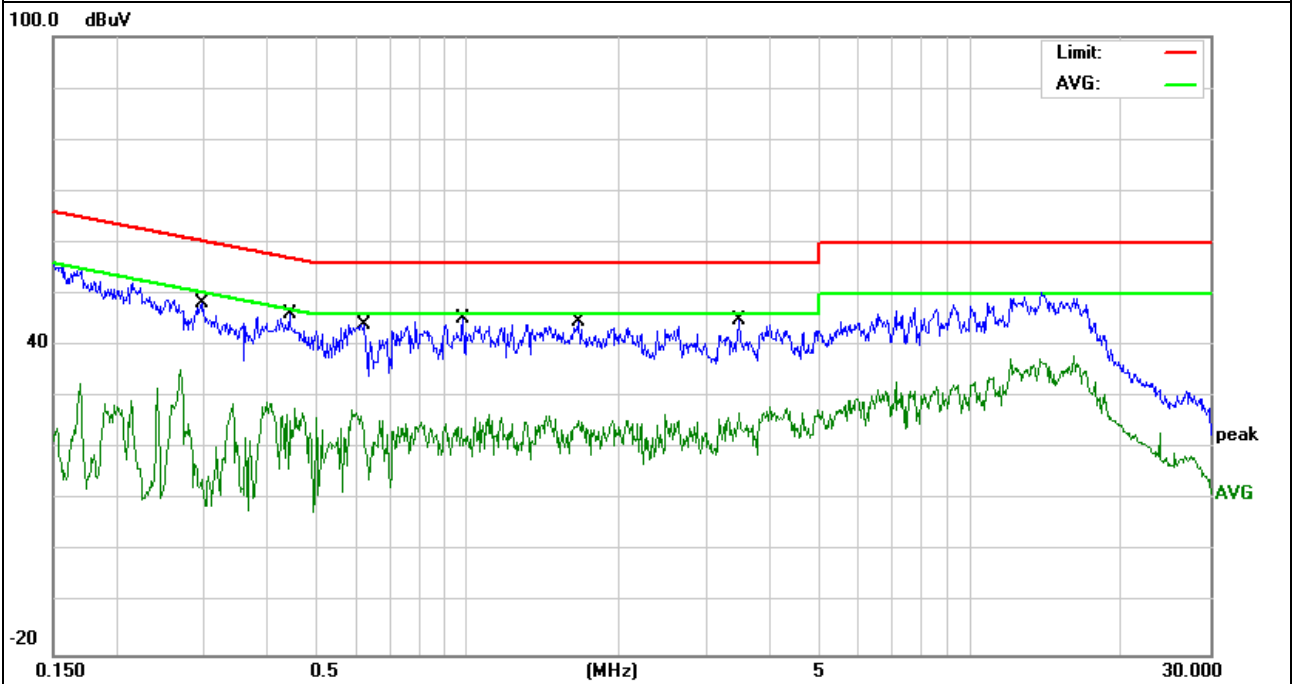

EUT :	Tablet PC	Model Name. :	Indi
Temperature :	26 °C	Relative Humidity :	56%
Pressure :	1010hPa	Phase :	N
Test Voltage :	DC 12V from adapter AC120V/60Hz	Test Mode :	Mode 1

Frequency (MHz)	Meter Reading (dBμV)	Factor (dB)	Emission Level (dBμV)	Limits (dBμV)	Margin (dB)	Detector Type
0.1862	44.19	10.11	54.3	64.2	-9.9	QP
0.1862	22.18	10.11	32.29	54.2	-21.91	AVG
0.2983	39.18	10.12	49.3	60.29	-10.99	QP
0.2983	-0.7	10.12	9.42	50.29	-40.87	AVG
1.006	33.43	9.76	43.19	56	-12.81	QP
1.006	8.43	9.76	18.19	46	-27.81	AVG
4.0857	32.71	9.79	42.5	56	-13.5	QP
4.0857	11.59	9.79	21.38	46	-24.62	AVG
8.7698	36.78	9.87	46.65	60	-13.35	QP
8.7698	19.02	9.87	28.89	50	-21.11	AVG
13.9059	37.81	9.95	47.76	60	-12.24	QP
13.9059	24.14	9.95	34.09	50	-15.91	AVG

Remark:

1. All readings are Quasi-Peak and Average values.
2. Factor = Insertion Loss + Cable Loss.

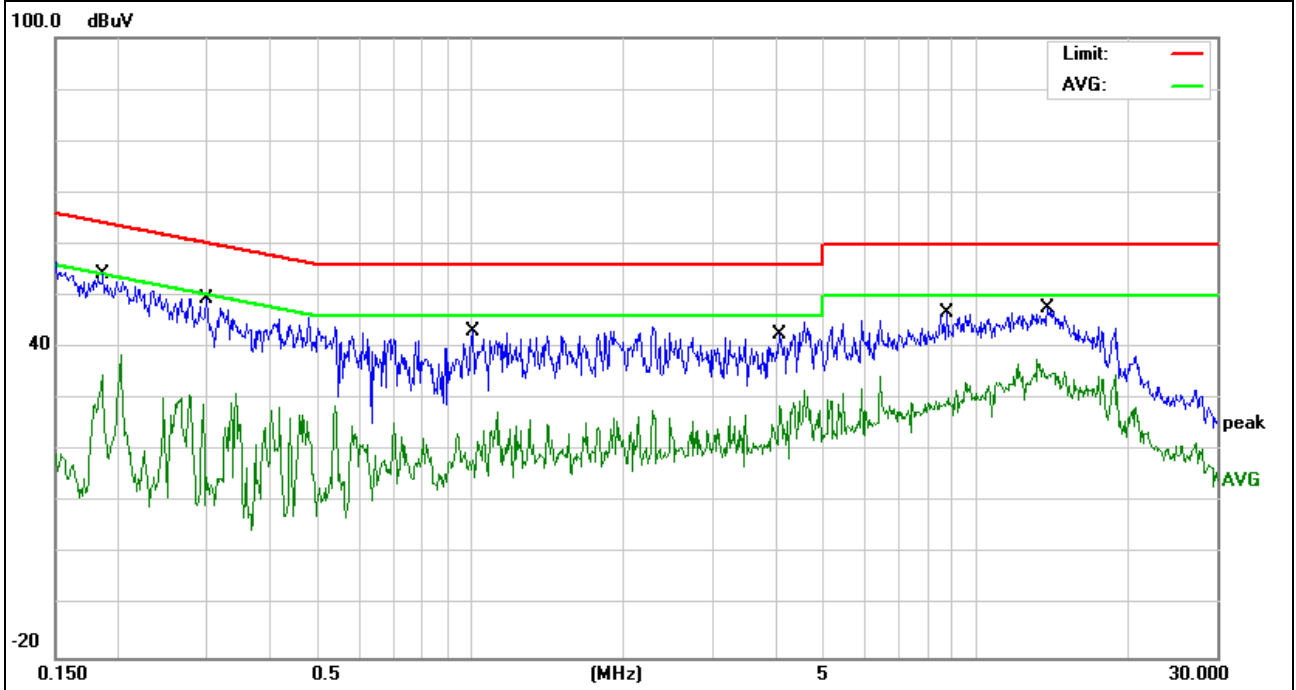

EUT :	Tablet PC	Model Name. :	Indi
Temperature :	26 °C	Relative Humidity :	56%
Pressure :	1010hPa	Phase :	L
Test Voltage :	DC 12V from adapter AC240V/60Hz	Test Mode :	Mode 1

Frequency (MHz)	Meter Reading (dBμV)	Factor (dB)	Emission Level (dBμV)	Limits (dBμV)	Margin (dB)	Detector Type
0.2403	40.05	10.15	50.2	62.08	-11.88	QP
0.2403	23.52	10.15	33.67	52.08	-18.41	AVG
0.8417	35.74	9.76	45.5	56	-10.5	QP
0.8417	14.27	9.76	24.03	46	-21.97	AVG
1.598	35.39	9.76	45.15	56	-10.85	QP
1.598	14.53	9.76	24.29	46	-21.71	AVG
2.1419	35.8	9.75	45.55	56	-10.45	QP
2.1419	15.17	9.75	24.92	46	-21.08	AVG
3.778	35	9.78	44.78	56	-11.22	QP
3.778	16.1	9.78	25.88	46	-20.12	AVG
9.6379	37.59	9.87	47.46	60	-12.54	QP
9.6379	22.09	9.87	31.96	50	-18.04	AVG

Remark:

1. All readings are Quasi-Peak and Average values.
2. Factor = Insertion Loss + Cable Loss.

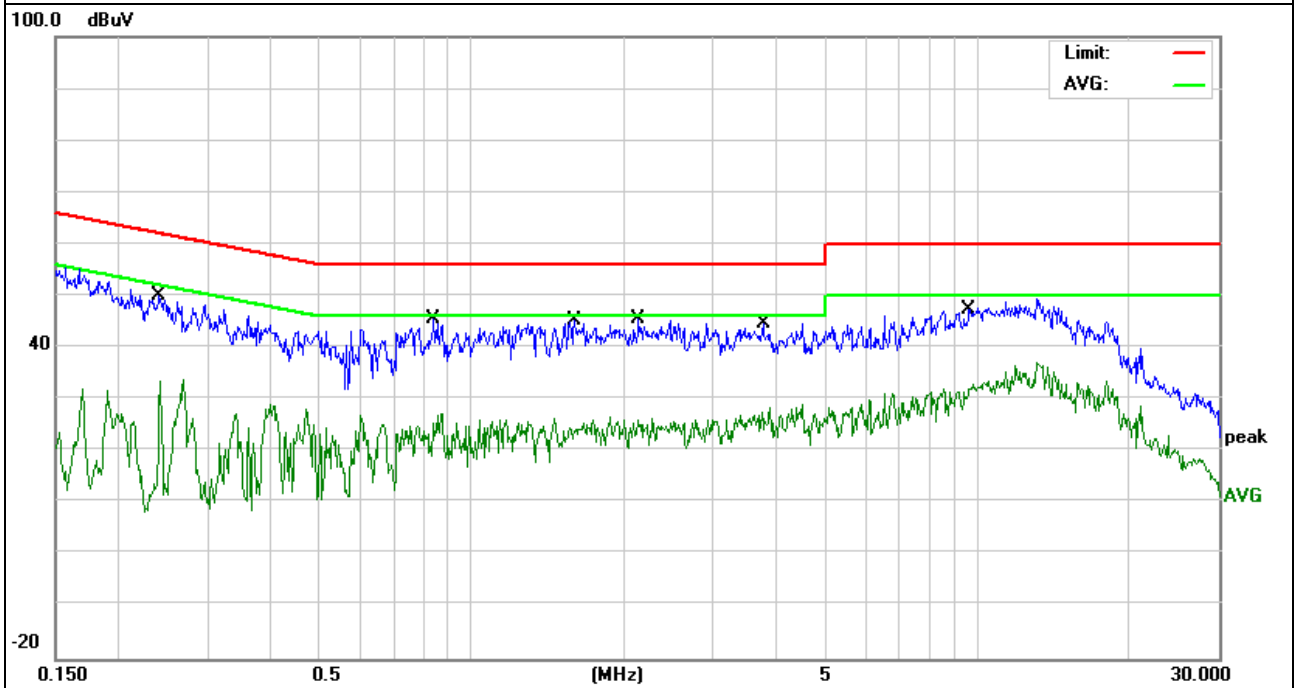

EUT :	Tablet PC	Model Name. :	Indi
Temperature :	26 °C	Relative Humidity :	56%
Pressure :	1010hPa	Phase :	N
Test Voltage :	DC 12V from adapter AC240V/60Hz	Test Mode :	Mode 1

Frequency (MHz)	Meter Reading (dBμV)	Factor (dB)	Emission Level (dBμV)	Limits (dBμV)	Margin (dB)	Detector Type
0.2353	40.87	10.13	51	62.26	-11.26	QP
0.2353	3.11	10.13	13.24	52.26	-39.02	AVG
0.386	36.24	9.96	46.2	58.15	-11.95	QP
0.386	6.3	9.96	16.26	48.15	-31.89	AVG
0.8699	32.93	9.77	42.7	56	-13.3	QP
0.8699	8.31	9.77	18.08	46	-27.92	AVG
1.6532	32.44	9.76	42.2	56	-13.8	QP
1.6532	15.08	9.76	24.84	46	-21.16	AVG
3.2179	33.52	9.78	43.3	56	-12.7	QP
3.2179	16.84	9.78	26.62	46	-19.38	AVG
6.2938	33.77	9.83	43.6	60	-16.4	QP
6.2938	17.52	9.83	27.35	50	-22.65	AVG

Remark:

1. All readings are Quasi-Peak and Average values.
2. Factor = Insertion Loss + Cable Loss.

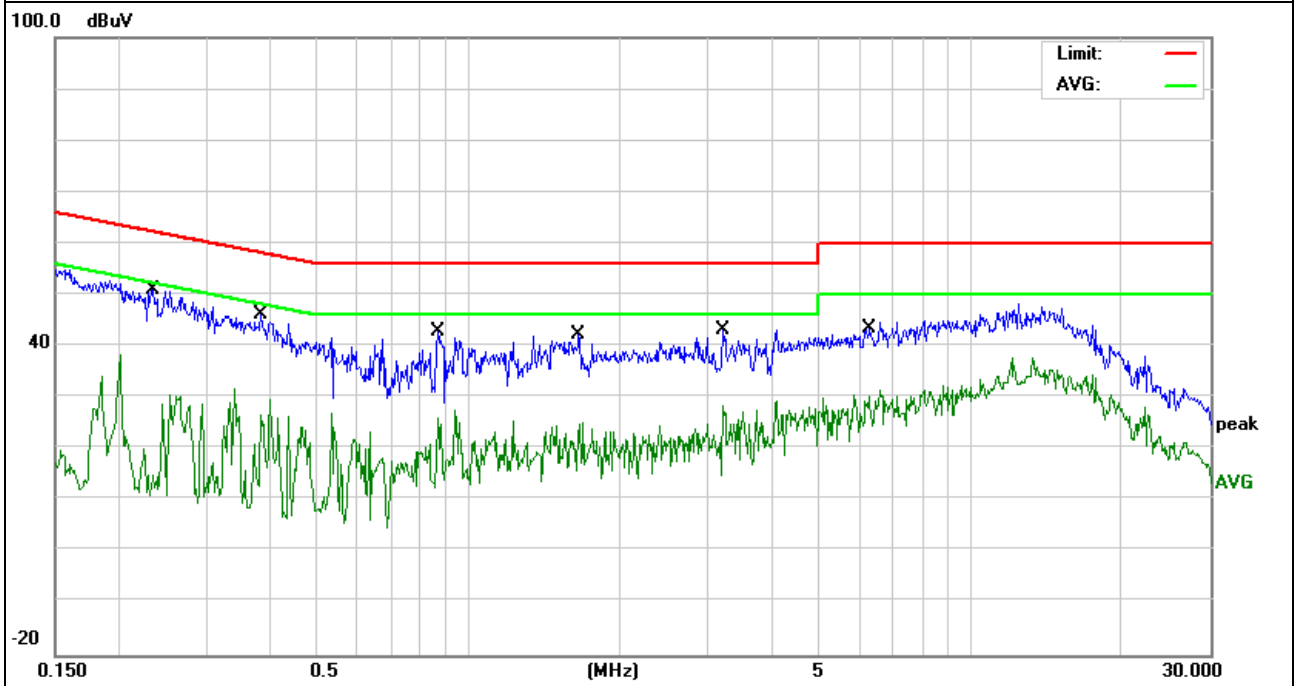

3.2 RADIATED EMISSION MEASUREMENT

3.2.1 APPLICABLE STANDARD

According to FCC Part 15.407(d) and 15.209

3.2.2 CONFORMANCE LIMIT

According to FCC Part 15.407(b)(7): radiated emissions which fall in the restricted bands, as defined in §15.205(a), must also comply with the radiated emission limits specified in §15.209(a) (see §15.205(c)).
According to FCC Part 15.205, Restricted bands

MHz	MHz	MHz	GHz
0.090-0.110	16.42-16.423	399.9-410	4.5-5.15
10.495-0.505	16.69475-16.69525	608-614	5.35-5.46
2.1735-2.1905	16.80425-16.80475	960-1240	7.25-7.75
4.125-4.128	25.5-25.67	1300-1427	8.025-8.5
4.17725-4.17775	37.5-38.25	1435-1626.5	9.0-9.2
4.20725-4.20775	73-74.6	1645.5-1646.5	9.3-9.5
6.215-6.218	74.8-75.2	1660-1710	10.6-12.7
6.26775-6.26825	123-138	2200-2300	14.47-14.5
8.291-8.294	149.9-150.05	2310-2390	15.35-16.2
8.362-8.366	156.52475-156.52525	2483.5-2500	17.7-21.4
8.37625-8.38675	156.7-156.9	2690-2900	22.01-23.12
8.41425-8.41475	162.0125-167.17	3260-3267	23.6-24.0
12.29-12.293	167.72-173.2	3332-3339	31.2-31.8
12.51975-12.52025	240-285	3345.8-3358	36.43-36.5
12.57675-12.57725	322-335.4	3600-4400	(2)
13.36-13.41			

20dBc in any 100 kHz bandwidth outside the operating frequency band. In case the emission fall within the restricted band specified on 15.205(a), then the 15.209(a) limit in the table below has to be followed.

Restricted Frequency(MHz)	Field Strength (µV/m)	Field Strength (dBµV/m)	Measurement Distance
0.009~0.490	2400/F(KHz)	20 log (uV/m)	300
0.490~1.705	2400/F(KHz)	20 log (uV/m)	30
1.705~30.0	30	29.5	30
30-88	100	40	3
88-216	150	43.5	3
216-960	200	46	3
Above 960	500	54	3

Limits of Radiated Emission Measurement(Above 1000MHz)

Frequency(MHz)	Class B (dBuV/m) (at 3M)	
	PEAK	AVERAGE
Above 1000	74	54

- Remark :1. Emission level in dBuV/m=20 log (uV/m)
 2. Measurement was performed at an antenna to the closed point of EUT distance of meters.
 3. Distance extrapolation factor =40log(Specific distance/ test distance)(dB);
 Limit line=Specific limits(dBuV) + distance extrapolation factor.

3.2.3 MEASURING INSTRUMENTS

The Measuring equipment is listed in the section 6.3 of this test report.

3.2.4 TEST CONFIGURATION

(a) For radiated emissions below 30MHz

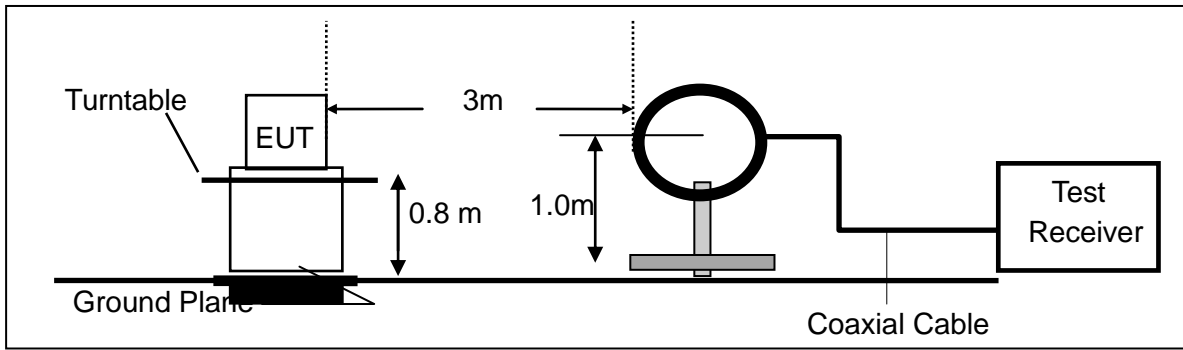

(b) For radiated emissions from 30MHz to 1000MHz

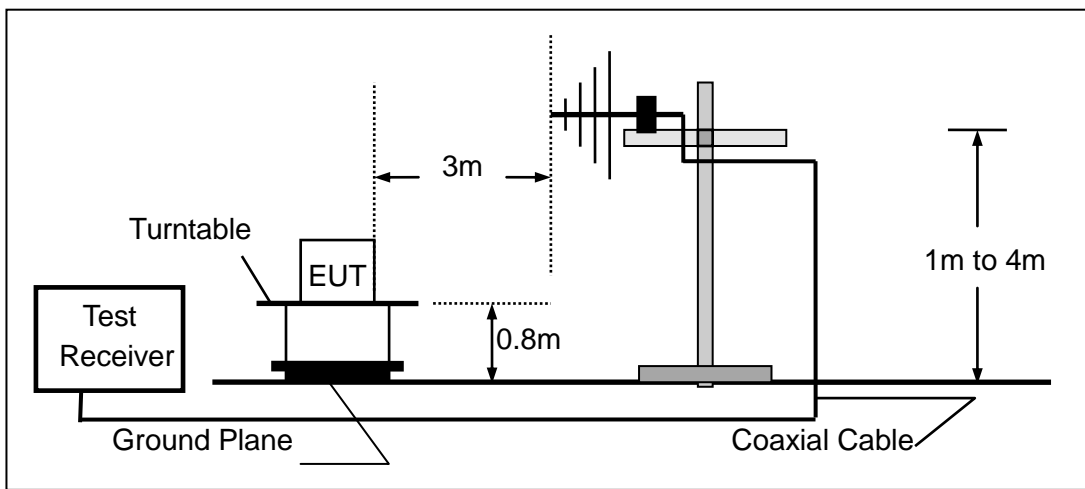

(c) For radiated emissions above 1000MHz

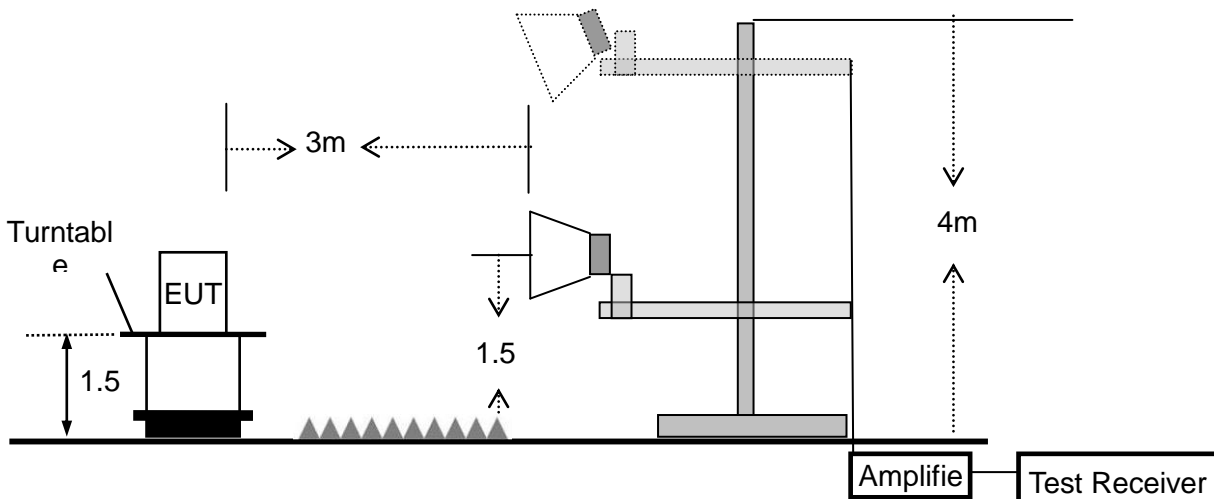

3.2.5 TEST PROCEDURE

The test site semi-anechoic chamber has met the requirement of NSA tolerance 4 dB according to the standards: ANSI C63.10-2013. The test distance is 3m. The setup is according to the requirements in Section 13.1.4.1 of ANSI C63.10-2013 and CAN/CSA-CEI/IEC CISPR 22.

This test is required for any spurious emission that falls in a Restricted Band, as defined in Section 15.205. It must be performed with the highest gain of each type of antenna proposed for use with the EUT.

Use the following spectrum analyzer settings:

Spectrum Parameter	Setting
Attenuation	Auto
Start Frequency	1000 MHz
Stop Frequency	10th carrier harmonic
RB / VB (emission in restricted band)	1 MHz / 1 MHz for Peak, 1 MHz / 10Hz for Average

Receiver Parameter	Setting
Attenuation	Auto
Start ~ Stop Frequency	9kHz~150kHz / RB 200Hz for QP
Start ~ Stop Frequency	150kHz~30MHz / RB 9kHz for QP
Start ~ Stop Frequency	30MHz~1000MHz / RB 120kHz for QP

- a. The measuring distance of at 3 m shall be used for measurements at frequency up to 1GHz. For frequencies above 1GHz, any suitable measuring distance may be used.
- b. The EUT was placed on the top of a rotating table 0.8 m for below 1GHz and 1.5m for above 1GHz the ground at a 3 meter. The table was rotated 360 degrees to determine the position of the highest radiation.
- c. The height of the equipment or of the substitution antenna shall be 0.8 m for below 1GHz and 1.5m for above 1GHz; the height of the test antenna shall vary between 1 m to 4 m. Both horizontal and vertical polarizations of the antenna are set to make the measurement.
- d. The initial step in collecting conducted emission data is a spectrum analyzer peak detector mode pre-scanning the measurement frequency range. Significant peaks are then marked and then Quasi Peak detector mode re-measured.
- e. If the Peak Mode measured value compliance with and lower than Quasi Peak Mode Limit, the EUT shall be deemed to meet QP Limits and then no additional QP Mode measurement performed.
- f. For the actual test configuration, please refer to the related Item –EUT Test Photos.

Note:

Both horizontal and vertical antenna polarities were tested and performed pretest to three orthogonal axis. The worst case emissions were reported

During the radiated emission test, the Spectrum Analyzer was set with the following configurations:

Frequency Band (MHz)	Function	Resolution bandwidth	Video Bandwidth
30 to 1000	QP	120 kHz	300 kHz
Above 1000	Peak	1 MHz	1 MHz
	Average	1 MHz	10 Hz

Note: for the frequency ranges below 30 MHz, a narrower RBW is used for these ranges but the measured value should add a RBW correction factor (RBWCF) where $RBWCF [dB] = 10 \cdot \lg(100 [kHz] / \text{narrower RBW [kHz]})$. , the narrower RBW is 1 kHz and RBWCF is 20 dB for the frequency 9 kHz to 150 kHz, and the narrower RBW is 10 kHz and RBWCF is 10 dB for the frequency 150 kHz to 30 MHz.

3.2.6 TEST RESULTS (BETWEEN 9KHZ – 30 MHZ)

EUT:	Tablet PC	Model Name. :	Indi
Temperature:	20 °C	Relative Humidity:	48%
Pressure:	1010 hPa	Test Voltage :	DC 7.4V
Test Mode :	TX	Polarization :	--

Freq. (MHz)	Reading (dBuV/m)	Limit (dBuV/m)	Margin (dB)	State P/F
--	--	--	--	N/A
--	--	--	--	N/A

NOTE:

The amplitude of spurious emissions which are attenuated by more than 20dB below the permissible value has no need to be reported.

Distance extrapolation factor = $40 \log(\text{specific distance}/\text{test distance})$ (dB);

Limit line = specific limits(dBuv) + distance extrapolation factor.

3.2.7 TEST RESULTS (BETWEEN 30MHZ – 1GHZ)

EUT :	Tablet PC	Model Name :	Indi
Temperature :	20 °C	Relative Humidity :	48%
Pressure :	1010 hPa	Test Voltage :	DC 7.4V
Test Mode :	TX(5.2G)- 802.11a (High CH)		

Polar (H/V)	Frequency	Meter Reading	Factor	Emission Level	Limits	Margin	Remark
	(MHz)	(dBuV)	(dB)	(dBuV/m)	(dBuV/m)	(dB)	
V	35.0048	14.98	17.22	32.2	40	-7.8	QP
V	114.9167	16.18	13.22	29.4	43.5	-14.1	QP
V	155.3642	17.61	12.59	30.2	43.5	-13.3	QP
V	199.9856	21.36	10.26	31.62	43.5	-11.88	QP
V	229.2931	16.71	12.23	28.94	46	-17.06	QP
V	562.6624	7.87	24.81	32.68	46	-13.32	QP

Remark:

Absolute Level= ReadingLevel+ Factor, Margin= Absolute Level - Limit

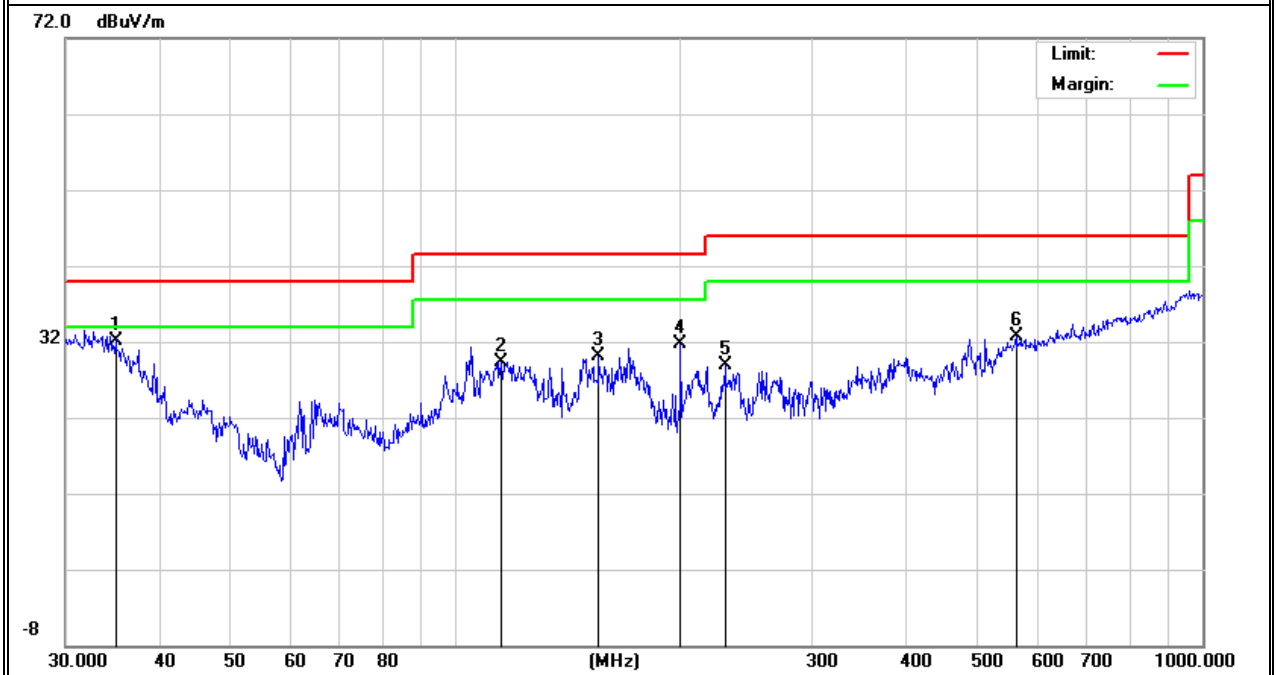

Polar (H/V)	Frequency	Meter Reading	Factor	Emission Level	Limits	Margin	Remark
	(MHz)	(dBuV)	(dB)	(dBuV/m)	(dBuV/m)	(dB)	
H	31.6202	6.38	19.02	25.4	40	-14.6	QP
H	95.7622	19.67	11.53	31.2	43.5	-12.3	QP
H	180.6484	19.23	11.47	30.7	43.5	-12.8	QP
H	245.9507	13.84	14.46	28.3	46	-17.7	QP
H	400.4318	10.48	20.23	30.71	46	-15.29	QP
H	601.4265	8.22	24.58	32.8	46	-13.2	QP

Remark:

Absolute Level= ReadingLevel+ Factor, Margin= Absolute Level - Limit

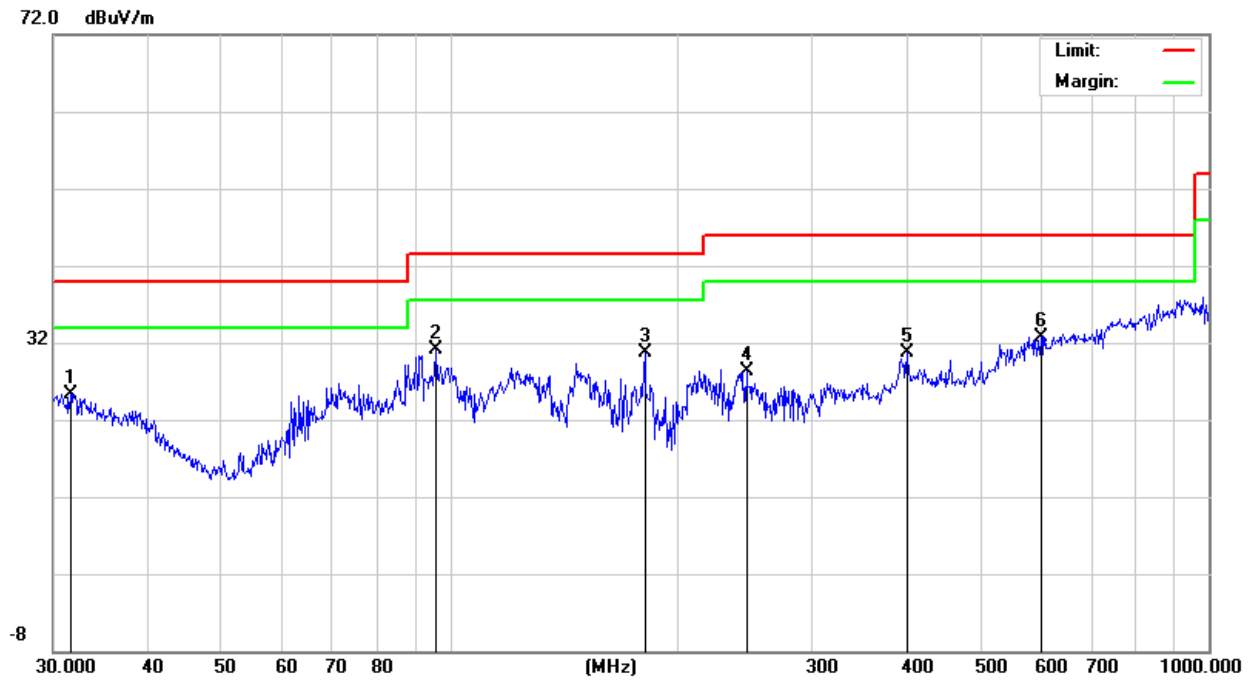

EUT :	Tablet PC	Model Name :	Indi
Temperature :	20 °C	Relative Humidity :	48%
Pressure :	1010 hPa	Test Voltage :	DC 7.4V
Test Mode :	TX(5.8G) - 802.11a (High CH)		

Polar (H/V)	Frequency	Meter Reading	Factor	Emission Level	Limits	Margin	Remark
	(MHz)	(dBuV)	(dB)	(dBuV/m)	(dBuV/m)	(dB)	
V	33.4448	15.75	18.05	33.8	40	-6.2	QP
V	119.436	16.14	13.8	29.94	43.5	-13.56	QP
V	162.6106	16.49	12.01	28.5	43.5	-15	QP
V	222.1698	15.06	12.34	27.4	46	-18.6	QP
V	462.3455	15.02	21.01	36.03	46	-9.97	QP
V	625.0778	13.76	25.02	38.78	46	-7.22	QP

Remark:

Absolute Level= ReadingLevel+ Factor, Margin= Absolute Level - Limit

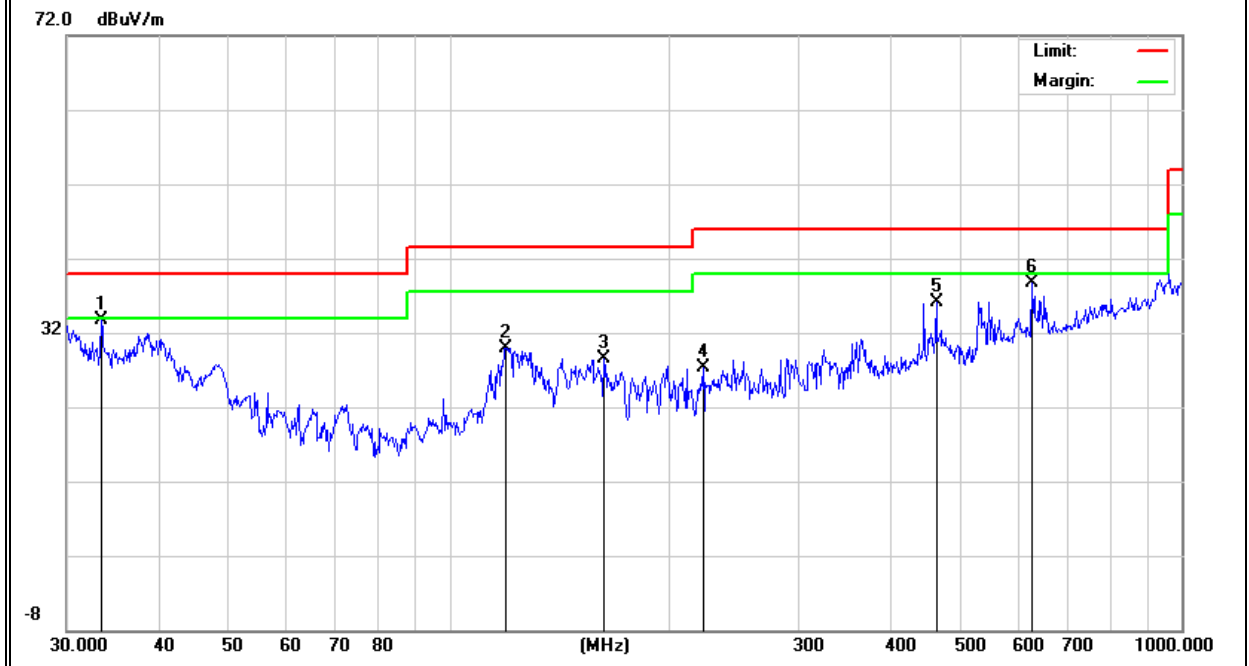

Polar (H/V)	Frequency	Meter Reading	Factor	Emission Level	Limits	Margin	Remark
	(MHz)	(dBuV)	(dB)	(dBuV/m)	(dBuV/m)	(dB)	
H	150.0107	18.77	13.07	31.84	43.5	-11.66	QP
H	251.1802	14.31	15.39	29.7	46	-16.3	QP
H	312.1792	19.65	16.65	36.3	46	-9.7	QP
H	443.2943	13.89	20.81	34.7	46	-11.3	QP
H	528.2458	12.78	23.36	36.14	46	-9.86	QP
H	833.317	11.19	28.65	39.84	46	-6.16	QP

Remark:

Absolute Level= ReadingLevel+ Factor, Margin= Absolute Level - Limit

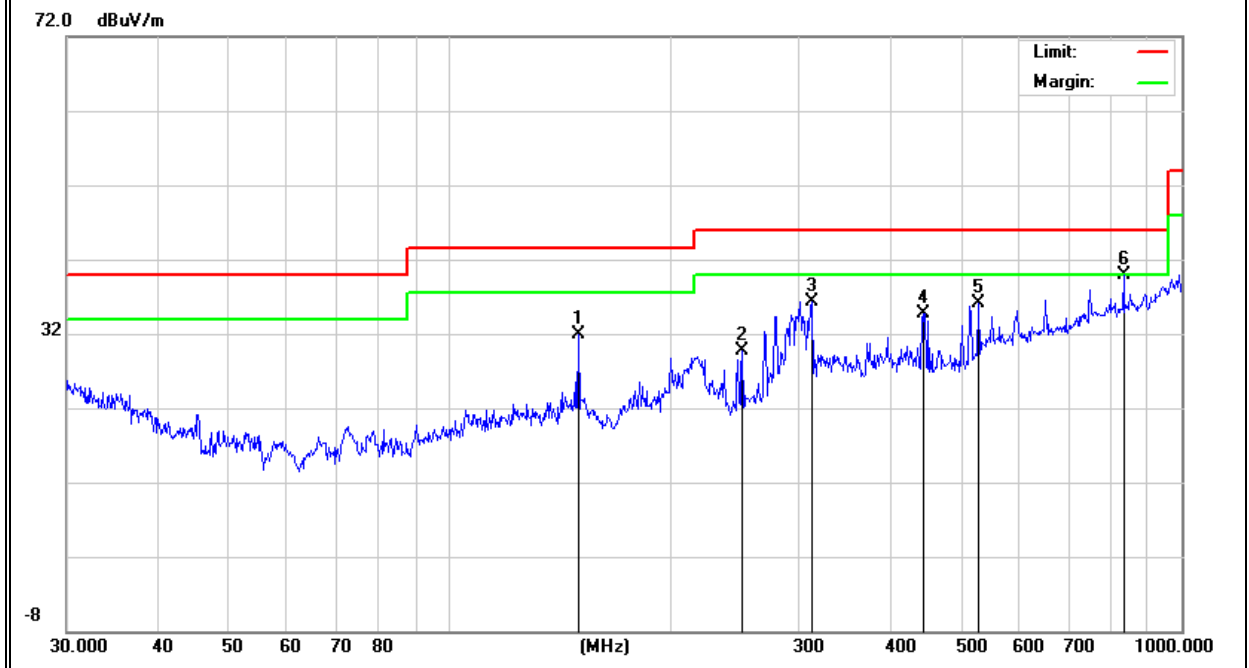

3.2.8 TEST RESULTS (1GHz-18GHz)

EUT :	Tablet PC	Model Name :	Indi
Temperature :	20 °C	Relative Humidity :	48%
Pressure :	1010 hPa	Test Voltage :	DC 7.4V
Test Mode :	TX (5.2G)-802.11a 5180MHz~5240MHz		

Polar	Frequency	Meter Reading	Cable loss	Antenna Factor	Preamplifier Factor	Emission Level	Limits	Margin	Detector Type
(H/V)	(MHz)	(dBuV)	(dB)	dB/m	(dB)	(dBuV/m)	(dBuV/m)	(dB)	
Low Channel (5180 MHz)-Above 1G									
Vertical	4434.513	54.16	5.94	35.40	44.00	51.5	74.00	-22.5	Pk
Vertical	4434.513	43.27	5.94	35.40	44.00	40.61	54.00	-13.39	AV
Vertical	10370.45	61.04	8.46	39.75	44.50	64.75	74.00	-9.25	Pk
Vertical	10370.45	45.62	8.46	39.75	44.50	49.33	54.00	-4.67	AV
Vertical	15540.24	55.08	10.12	38.80	44.10	59.9	74.00	-14.1	Pk
Vertical	15540.24	41.67	10.12	38.80	42.70	47.89	54.00	-6.11	AV
Horizontal	4434.745	57.61	5.94	35.18	44.00	54.73	74.00	-19.27	Pk
Horizontal	4434.745	42.19	5.94	35.18	44.00	39.31	54.00	-14.69	AV
Horizontal	10370.21	60.34	8.46	38.71	44.50	63.01	74.00	-10.99	Pk
Horizontal	10730.21	46.26	8.46	38.71	44.50	48.93	54.00	-5.07	AV
Horizontal	15540.52	56.15	10.12	38.38	44.10	60.55	74.00	-13.45	Pk
Horizontal	15540.52	41.97	10.12	38.38	44.10	46.37	54.00	-7.63	AV
middle Channel (5200 MHz)-Above 1G									
Vertical	4592.232	56.33	6.48	36.35	44.05	55.11	74.00	-18.89	Pk
Vertical	4592.232	41.64	6.48	36.35	44.05	40.42	54.00	-13.58	AV
Vertical	10401.22	60.35	8.47	37.88	44.51	62.19	74.00	-11.81	Pk
Vertical	10401.22	45.15	8.47	37.88	44.51	46.99	54.00	-7.01	AV
Vertical	15600.17	56.21	10.12	38.8	44.10	61.03	74.00	-12.97	Pk
Vertical	15600.17	41.82	10.12	38.8	42.70	48.04	54.00	-5.96	AV
Horizontal	4592.416	58.61	6.48	36.37	44.05	57.41	74.00	-16.59	Pk
Horizontal	4592.416	41.21	6.48	36.37	44.05	40.01	54.00	-13.99	AV
Horizontal	10400.16	60.38	8.47	38.64	44.50	62.99	74.00	-11.01	Pk
Horizontal	10400.16	46.19	8.47	38.64	44.50	48.8	54.00	-5.2	AV
Horizontal	15600.18	57.32	10.12	38.38	44.10	61.72	74.00	-12.28	Pk
Horizontal	15600.18	41.82	10.12	38.38	44.10	46.22	54.00	-7.78	AV
High Channel (5240 MHz)-Above 1G									
Vertical	4739.218	58.13	7.10	37.24	43.50	58.97	74.00	-15.03	Pk
Vertical	4739.218	45.17	7.10	37.24	43.50	46.01	54.00	-7.99	AV
Vertical	10480.27	60.31	8.46	37.68	44.50	61.95	74.00	-12.05	Pk
Vertical	10480.27	45.18	8.46	37.68	44.50	46.82	54.00	-7.18	AV
Vertical	15720.13	57.04	10.12	38.8	44.10	61.86	74.00	-12.14	Pk
Vertical	15720.13	42.1	10.12	38.8	42.70	48.32	54.00	-5.68	AV
Horizontal	4739.154	58.61	7.10	37.24	43.50	59.45	74.00	-14.55	Pk
Horizontal	4739.154	43.11	7.10	37.24	43.50	43.95	54.00	-10.05	AV
Horizontal	10481.62	57.81	8.46	38.57	44.50	60.34	74.00	-13.66	Pk
Horizontal	10481.62	42.16	8.46	38.57	44.50	44.69	54.00	-9.31	AV
Horizontal	15720.25	56.24	10.12	38.38	44.10	60.64	74.00	-13.36	Pk
Horizontal	15720.25	41.08	10.12	38.38	44.10	45.48	54.00	-8.52	AV

Note: "802.11N(20)(5G)" mode is the worst mode. PK value is lower than the Average value limit, So average didn't record.

The amplitude of spurious emissions that are attenuated by more than 20dB below the permissible value has no need to be reported.

Emission level (dBuV/m) = 20 log Emission level (uV/m).

Corrected Reading: Antenna Factor + Cable Loss + Read Level - Preamp Factor = Level.

EUT :	Tablet PC	Model Name :	Indi
Temperature :	20 °C	Relative Humidity :	48%
Pressure :	1010 hPa	Test Voltage :	DC 7.4V
Test Mode :	TX (5.8G) -802.11a 5745MHz~5825MHz		

Polar	Frequency	Meter Reading	Cable loss	Antenna Factor	Preamp Factor	Emission Level	Limits	Margin	Detector Type
(H/V)	(MHz)	(dBuV)	(dB)	dB/m	(dB)	(dBuV/m)	(dBuV/m)	(dB)	
Low Channel (5745 MHz)-Above 1G									
Vertical	4679.138	52.13	5.94	35.40	44.00	49.47	74.00	-24.53	Pk
Vertical	4679.138	45.59	5.94	35.40	44.00	42.93	54.00	-11.07	AV
Vertical	11490.227	60.67	8.46	39.75	44.50	64.38	74.00	-9.62	Pk
Vertical	11490.227	44.15	8.46	39.75	44.50	47.86	54.00	-6.14	AV
Vertical	17235.439	56.84	10.12	38.80	44.10	61.66	74.00	-12.34	Pk
Vertical	17235.439	40.26	10.12	38.80	42.70	46.48	54.00	-7.52	AV
Horizontal	4679.129	57.51	5.94	35.18	44.00	54.63	74.00	-19.37	Pk
Horizontal	4679.129	44.18	5.94	35.18	44.00	41.3	54.00	-12.7	AV
Horizontal	11490.124	59.86	8.46	38.71	44.50	62.53	74.00	-11.47	Pk
Horizontal	11490.124	44.31	8.46	38.71	44.50	46.98	54.00	-7.02	AV
Horizontal	17235.439	58.16	10.12	38.38	44.10	62.56	74.00	-11.44	Pk
Horizontal	17235.439	42.86	10.12	38.38	44.10	47.26	54.00	-6.74	AV
middle Channel (5785 MHz)-Above 1G									
Vertical	4592.201	58.64	6.48	36.35	44.05	57.42	74.00	-16.58	Pk
Vertical	4592.201	43.18	6.48	36.35	44.05	41.96	54.00	-12.04	AV
Vertical	11570.199	59.85	8.47	37.88	44.51	61.69	74.00	-12.31	Pk
Vertical	11570.199	43.85	8.47	37.88	44.51	45.69	54.00	-8.31	AV
Vertical	17355.128	57.18	10.12	38.8	44.10	62	74.00	-12	Pk
Vertical	17355.128	40.16	10.12	38.8	42.70	46.38	54.00	-7.62	AV
Horizontal	4592.587	59.88	6.48	36.37	44.05	58.68	74.00	-15.32	Pk
Horizontal	4592.587	43.27	6.48	36.37	44.05	42.07	54.00	-11.93	AV
Horizontal	11570.154	60.56	8.47	38.64	44.50	63.17	74.00	-10.83	Pk
Horizontal	11570.154	46.26	8.47	38.64	44.50	48.87	54.00	-5.13	AV
Horizontal	17355.263	59.86	10.12	38.38	44.10	64.26	74.00	-9.74	Pk
Horizontal	17355.263	44.31	10.12	38.38	44.10	48.71	54.00	-5.29	AV
High Channel (5825 MHz)-Above 1G									
Vertical	5039.235	58.96	7.10	37.24	43.50	59.8	74.00	-14.2	Pk
Vertical	5039.235	46.62	7.10	37.24	43.50	47.46	54.00	-6.54	AV
Vertical	11650.838	55.53	8.46	37.68	44.50	57.17	74.00	-16.83	Pk
Vertical	11650.838	42.27	8.46	37.68	44.50	43.91	54.00	-10.09	AV
Vertical	17475.128	59.86	10.12	38.8	44.10	64.68	74.00	-9.32	Pk
Vertical	17475.128	39.97	10.12	38.8	42.70	46.19	54.00	-7.81	AV
Horizontal	5039.101	66.69	7.10	37.24	43.50	67.53	74.00	-6.47	Pk
Horizontal	5039.101	42.2	7.10	37.24	43.50	43.04	54.00	-10.96	AV
Horizontal	11650.283	56.63	8.46	38.57	44.50	59.16	74.00	-14.84	Pk
Horizontal	11650.283	43.77	8.46	38.57	44.50	46.3	54.00	-7.7	AV
Horizontal	17475.103	59.86	10.12	38.38	44.10	64.26	74.00	-9.74	Pk
Horizontal	17475.103	44.31	10.12	38.38	44.10	48.71	54.00	-5.29	AV

Note: "802.11N(20)(5G)" mode is the worst mode. PK value is lower than the Average value limit, So average didn't record.

The amplitude of spurious emissions that are attenuated by more than 20dB below the permissible value has no need to be reported.

Emission level (dBuV/m) = 20 log Emission level (uV/m).

Corrected Reading: Antenna Factor + Cable Loss + Read Level - Preamp Factor = Level.

TEST RESULTS (18GHz-40GHz)

EUT :	Tablet PC	Model Name :	Indi
Temperature :	20 °C	Relative Humidity :	48%
Pressure :	1010 hPa	Test Voltage :	DC 7.4V
Test Mode :	TX (5.2G)-802.11a 5180MHz~5240MHz , TX (5.8G) -802.11a 5745MHz~5825MHz		

All the modulation modes have been tested, and the worst result was report as below:
 Channel (5180 MHz) 18-26.5G

Horizontal

FCC Electric Field Strength 18-26.5GHz

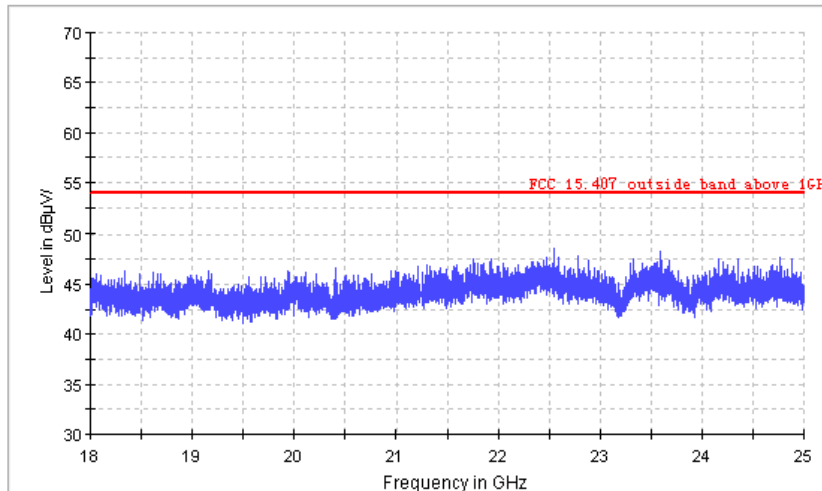

Vertical

FCC Electric Field Strength 18-26.5GHz

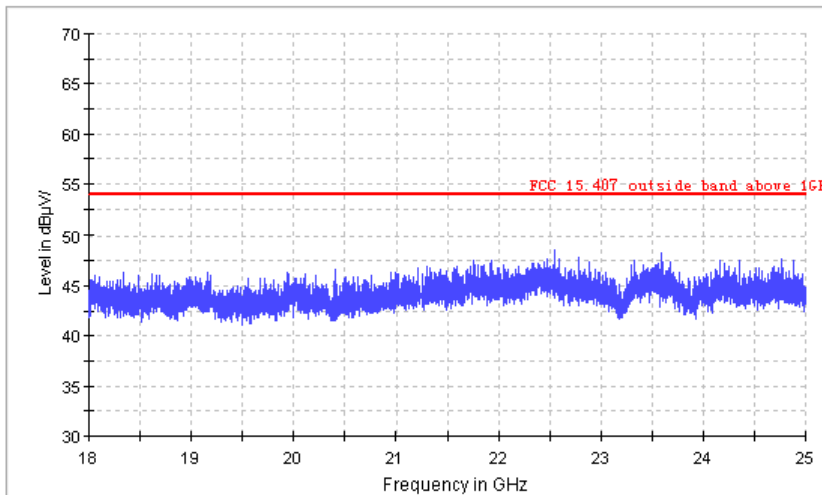

Channel (5180 MHz) 26.5-40G

Horizontal

FCC Electric Field Strength 26.5-40GHz

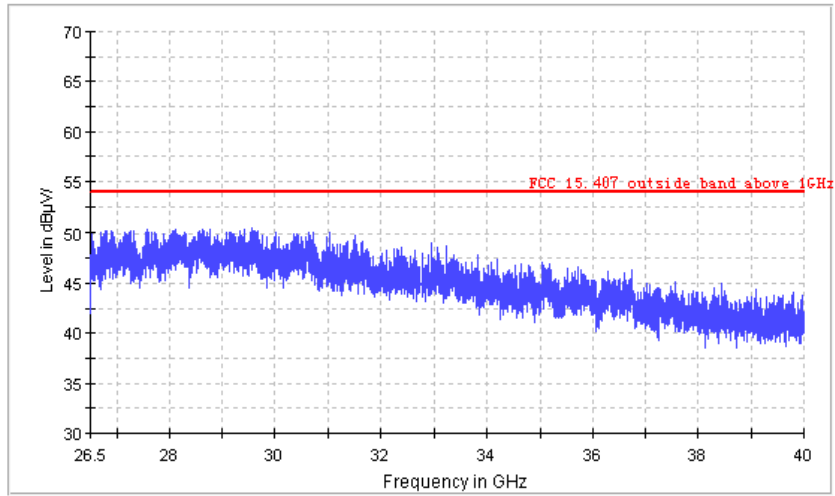

Vertical

FCC Electric Field Strength 26.5-40GHz

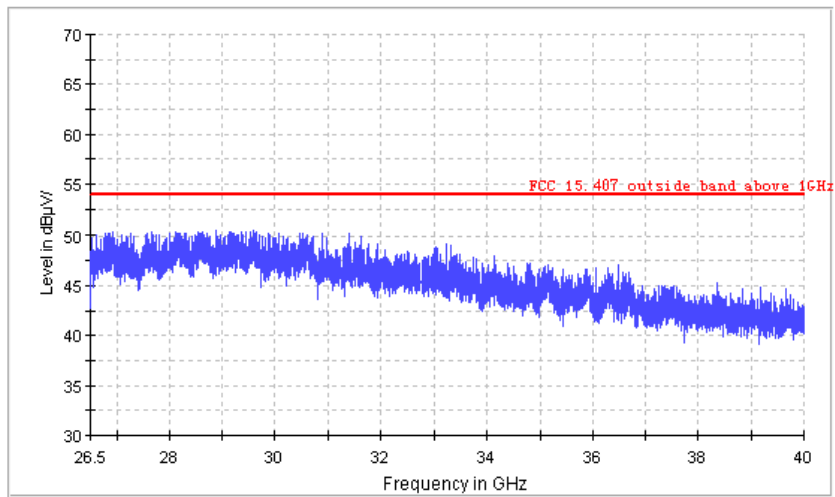

Channel (5745 MHz) 18-26.5G

Horizontal

FCC Electric Field Strength 18-26.5GHz

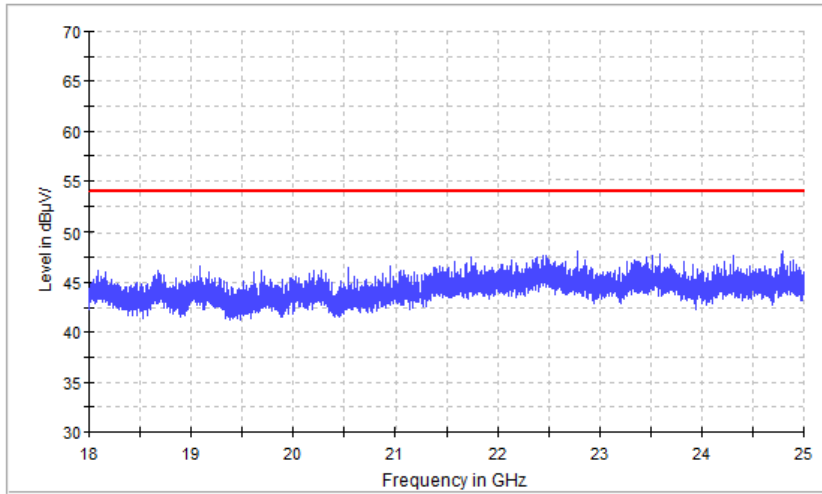

Vertical

FCC Electric Field Strength 18-26.5GHz

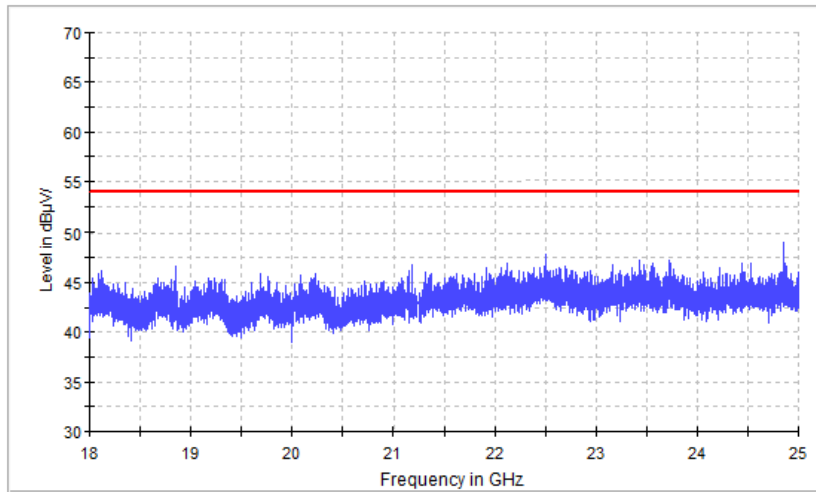

Channel (5745 MHz) 26.5-40G

Horizontal

FCC Electric Field Strength 26.5-40GHz

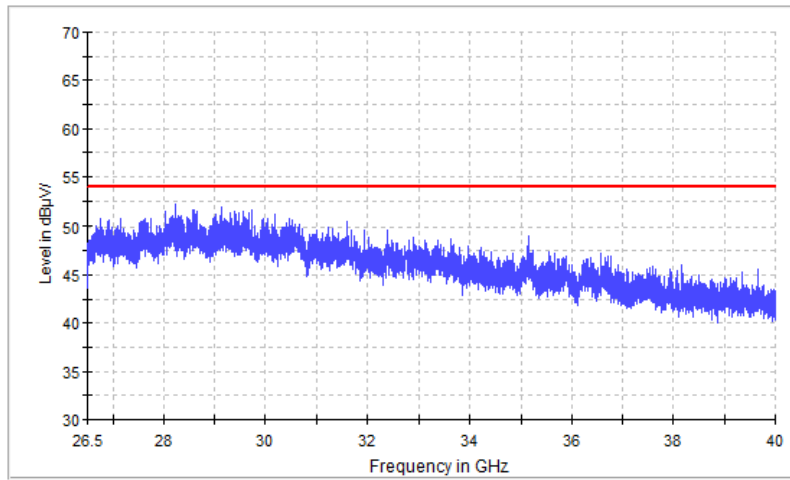

Vertical

FCC Electric Field Strength 26.5-40GHz

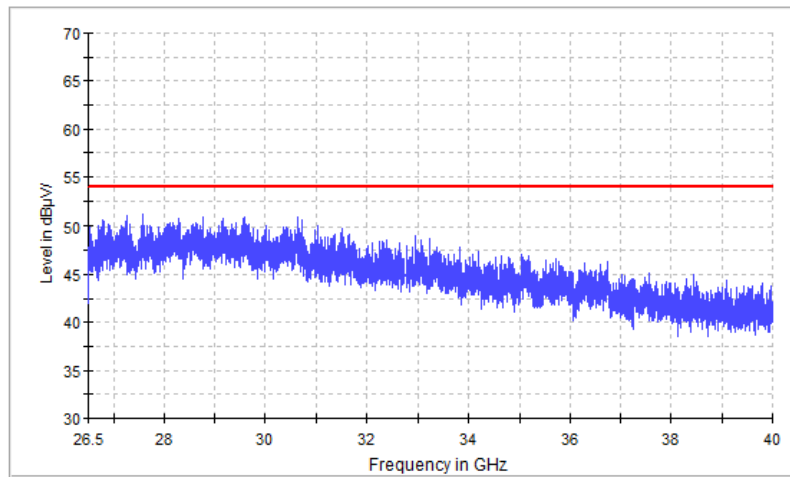

4. POWER SPECTRAL DENSITY TEST

4.1 APPLIED PROCEDURES / LIMIT

According to FCC §15.407(a)(3)

For the band 5.15-5.25 GHz,

(i) For an outdoor access point operating in the band 5.15-5.25 GHz, the maximum power spectral density shall not exceed 17 dBm in any 1 megahertz band. If transmitting antennas of directional gain greater than 6 dBi are used, both the maximum conducted output power and the maximum power spectral density shall be reduced by the amount in dB that the directional gain of the antenna exceeds 6 dBi. The maximum e.i.r.p. at any elevation angle above 30 degrees as measured from the horizon must not exceed 125 mW (21 dBm).

(ii) For an indoor access point operating in the band 5.15-5.25 GHz, the maximum power spectral density shall not exceed 17 dBm in any 1 megahertz band. If transmitting antennas of directional gain greater than 6 dBi are used, both the maximum conducted output power and the maximum power spectral density shall be reduced by the amount in dB that the directional gain of the antenna exceeds 6 dBi.

(iii) For fixed point-to-point access points operating in the band 5.15-5.25 GHz, the maximum power spectral density shall not exceed 17 dBm in any 1 megahertz band. Fixed point-to-point U-NII devices may employ antennas with directional gain up to 23 dBi without any corresponding reduction in the maximum conducted output power or maximum power spectral density. For fixed point-to-point transmitters that employ a directional antenna gain greater than 23 dBi, a 1 dB reduction in maximum conducted output power and maximum power spectral density is required for each 1 dB of antenna gain in excess of 23 dBi. Fixed, point-to-point operations exclude the use of point-to-multipoint systems, omnidirectional applications, and multiple collocated transmitters transmitting the same information. The operator of the U-NII device, or if the equipment is professionally installed, the installer, is responsible for ensuring that systems employing high gain directional antennas are used exclusively for fixed, point-to-point operations.

(iv) For mobile and portable client devices in the 5.15-5.25 GHz band, the maximum power spectral density shall not exceed 11 dBm in any 1 megahertz band. If transmitting antennas of directional gain greater than 6 dBi are used, both the maximum conducted output power and the maximum power spectral density shall be reduced by the amount in dB that the directional gain of the antenna exceeds 6 dBi.

For the band 5.725-5.85 GHz

(3) For the band 5.725-5.85 GHz, the maximum power spectral density shall not exceed 30 dBm in any 500-kHz band. If transmitting antennas of directional gain greater than 6 dBi are used, both the maximum conducted output power and the maximum power spectral density shall be reduced by the amount in dB that the directional gain of the antenna exceeds 6 dBi.

4.2 TEST PROCEDURE

For devices operating in the bands 5.15-5.25 GHz, 5.25-5.35 GHz, and 5.47-5.725 GHz, the above procedures make use of 1 MHz RBW to satisfy directly the 1 MHz reference bandwidth specified in § 15.407(a)(5). For devices operating in the band 5.725-5.85 GHz, the rules specify a measurement bandwidth of 500 kHz. Many spectrum analyzers do not have 500 kHz RBW, thus a narrower RBW may need to be used. The rules permit the use of a RBWs less than 1 MHz, or 500 kHz, “provided that the measured power is integrated over the full reference bandwidth” to show the total power over the specified measurement bandwidth (i.e., 1 MHz, or 500 kHz). If measurements are performed using a reduced resolution bandwidth (< 1 MHz, or < 500 kHz) and integrated over 1 MHz, or 500 KHz bandwidth, the following adjustments to the procedures apply:

- a) Set $RBW \geq 1/T$, where T is defined in section II.B.I.a).
- b) Set $VBW \geq 3 RBW$.
- c) If measurement bandwidth of Maximum PSD is specified in 500 kHz, add $10\log(500kHz/RBW)$ to the measured result, whereas $RBW (< 500 KHz)$ is the reduced resolution bandwidth of the spectrum analyzer set during measurement.
- d) If measurement bandwidth of Maximum PSD is specified in 1 MHz, add $10\log(1MHz/RBW)$ to the measured result, whereas $RBW (< 1 MHz)$ is the reduced resolution bandwidth of spectrum analyzer set during measurement.
- e) Care must be taken to ensure that the measurements are performed during a period of continuous transmission or are corrected upward for duty cycle.

Note: As a practical matter, it is recommended to use reduced RBW of 100 KHz for the sections 5.c) and 5.d) above, since $RBW=100 KHZ$ is available on nearly all spectrum analyzers.

4.3 DEVIATION FROM STANDARD

No deviation.

4.4 TEST SETUP



4.5 EUT OPERATION CONDITIONS

The EUT tested system was configured as the statements of 2.1 Unless otherwise a special operating condition is specified in the follows during the testing.

4.6 TEST RESULTS

EUT :	Tablet PC	Model Name :	Indi
Temperature :	25 °C	Relative Humidity :	56%
Pressure :	1015 hPa	Test Voltage :	DC 7.4V
Test Mode :	TX Frequency (5150-5250MHz)		

Mode	Frequency	Measured Power Density (dBm)	Limit (dBm)	Result
802.11 a	5185 MHz	3.21	11	PASS
	5200 MHz	3.14	11	PASS
	5240 MHz	4.05	11	PASS
802.11 n20	5185 MHz	1.44	11	PASS
	5200 MHz	1.84	11	PASS
	5240 MHz	2.54	11	PASS
802.11 n40	5190 MHz	-0.96	11	PASS
	5230 MHz	-0.79	11	PASS

Note: 1. Calculate power density= Measured Power Density+10log(1MHz/RBW)
 RBW=1MHz

(802.11a) PSD plot on channel 36

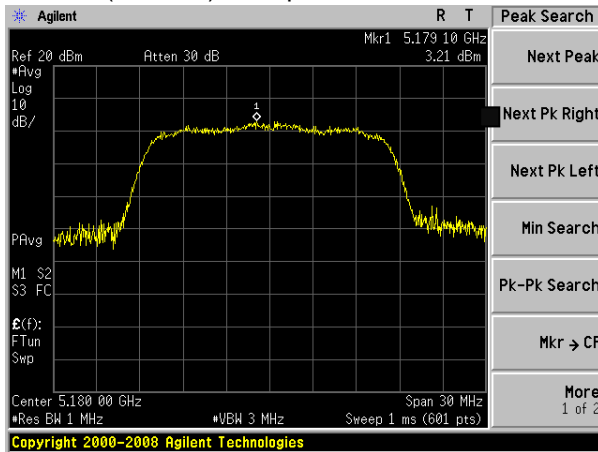

(802.11n20) PSD plot on channel 36

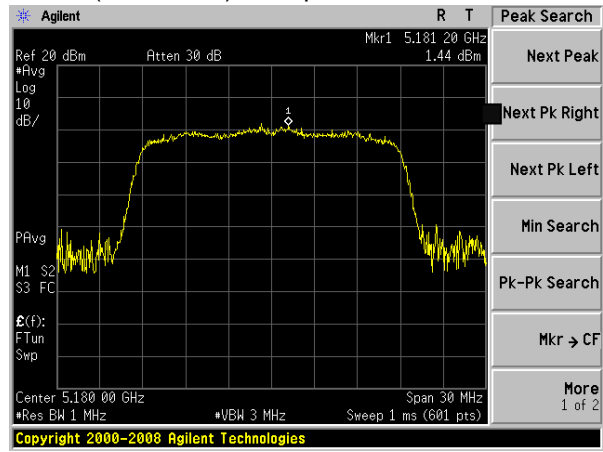

(802.11a) PSD plot on channel 40

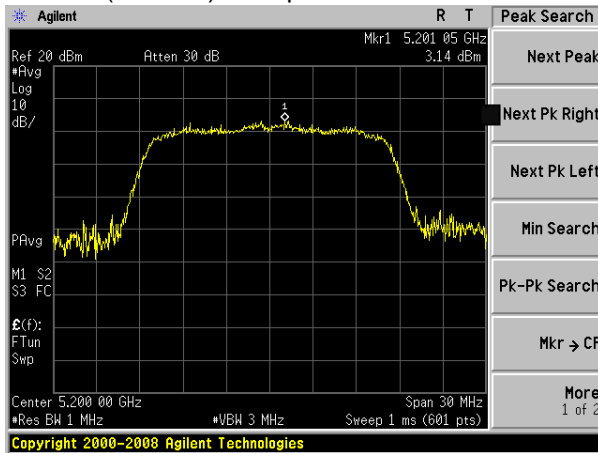

(802.11n20) PSD plot on channel 40

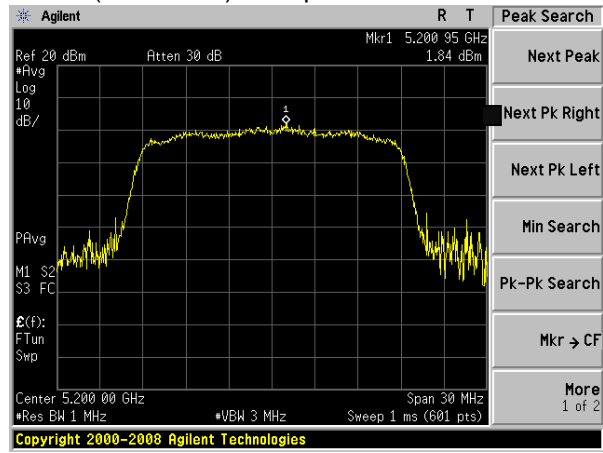

(802.11a) PSD plot on channel 48

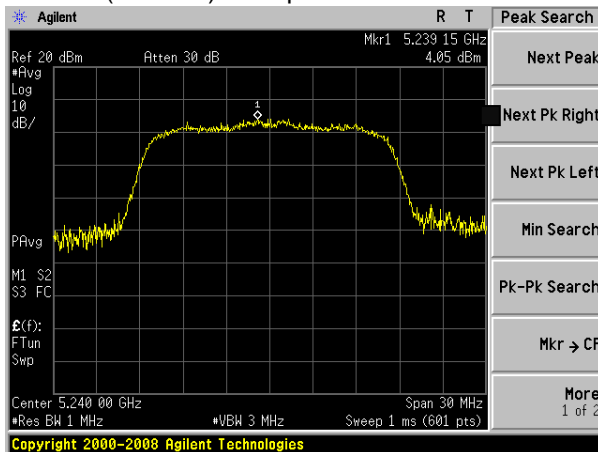

(802.11n20) PSD plot on channel 48

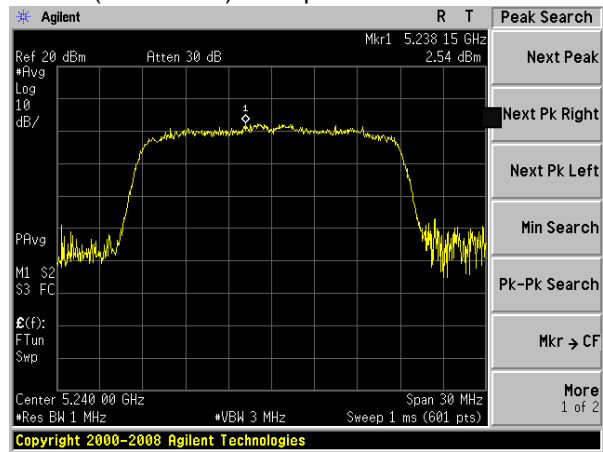

(802.11n40) PSD plot on channel 38

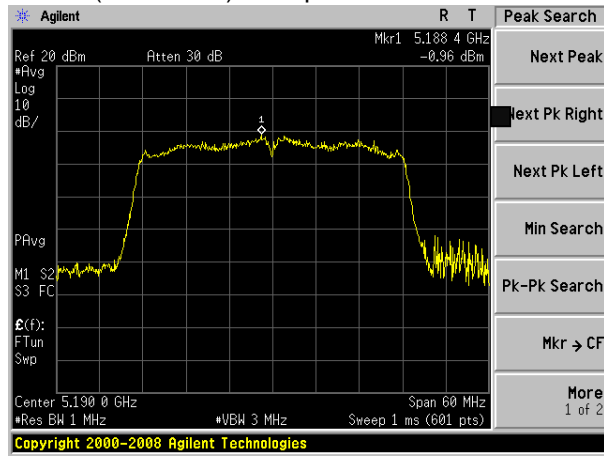

(802.11n40) PSD plot on channel 46

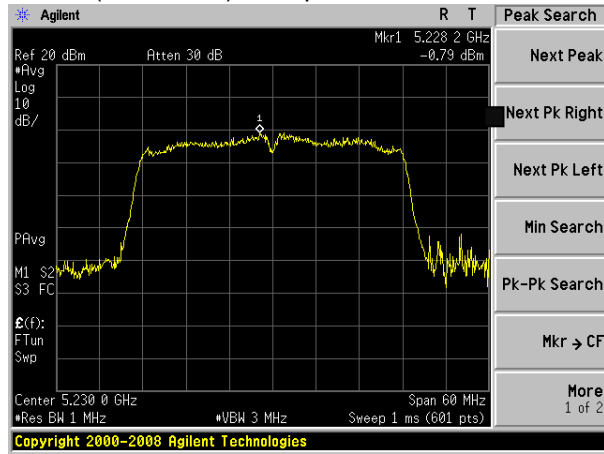

EUT :	Tablet PC	Model Name :	Indi
Temperature :	25 °C	Relative Humidity :	56%
Pressure :	1015 hPa	Test Voltage :	DC 7.4V
Test Mode :	TX Frequency (5725-5850MHz)		

Mode	Frequency	Measured Power Density(dBm)	Limit (dBm)	Result
802.11 a	5745 MHz	4.74	30	PASS
	5785 MHz	3.56	30	PASS
	5825 MHz	1.99	30	PASS
802.11 n20	5745 MHz	2.42	30	PASS
	5785 MHz	1.37	30	PASS
	5825 MHz	0.88	30	PASS
802.11 n40	5755 MHz	-1.61	30	PASS
	5795 MHz	-1.78	30	PASS

Note:

- (1) Calculate power density= Measured Power Density+10log(1MHz/RBW)
RBW=0.51MHz

(802.11a) PSD plot on channel 149

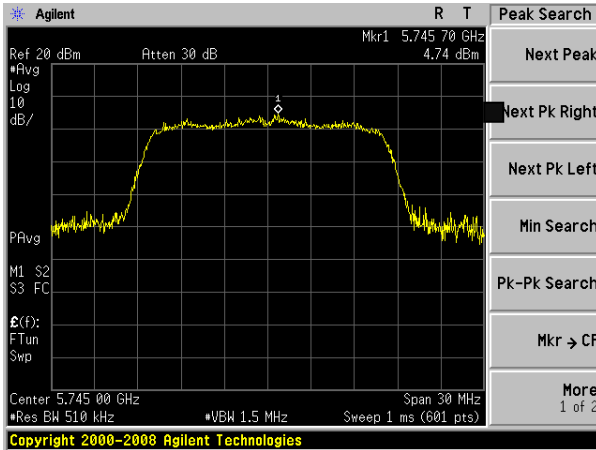

(802.11n20) PSD plot on channel 149

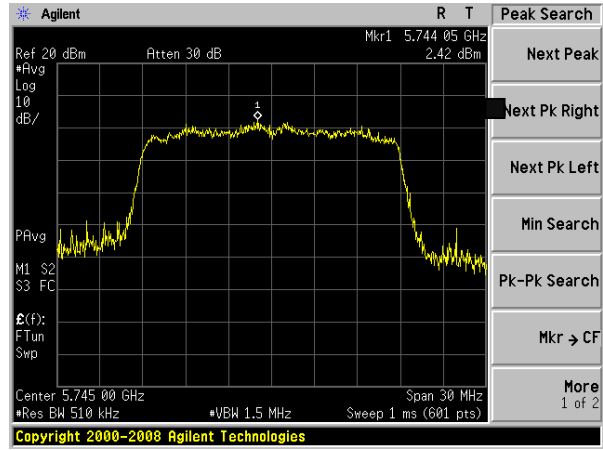

(802.11a) PSD plot on channel 157

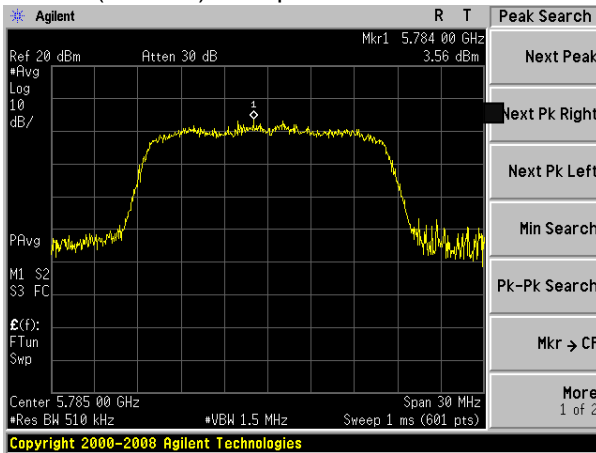

(802.11n20) PSD plot on channel 157

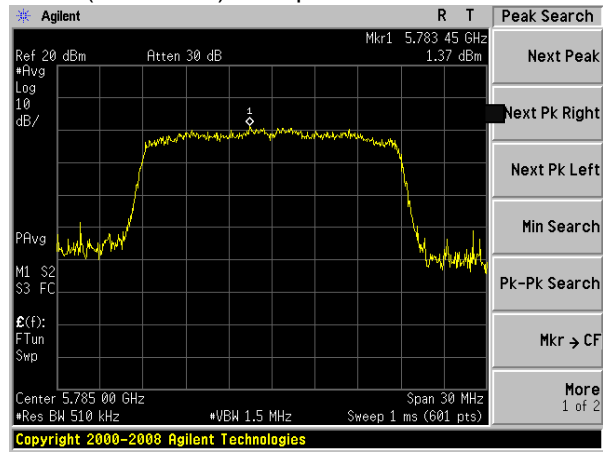

(802.11a) PSD plot on channel 165

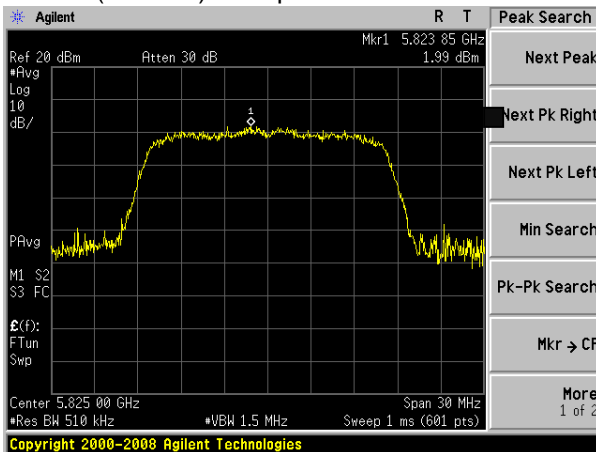

(802.11n20) PSD plot on channel 165

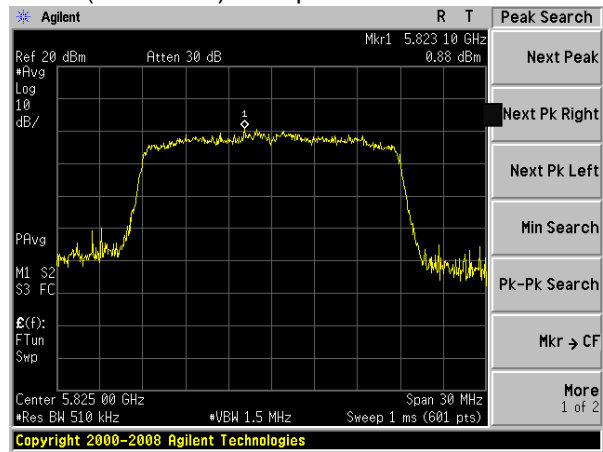

(802.11n40) PSD plot on channel 151

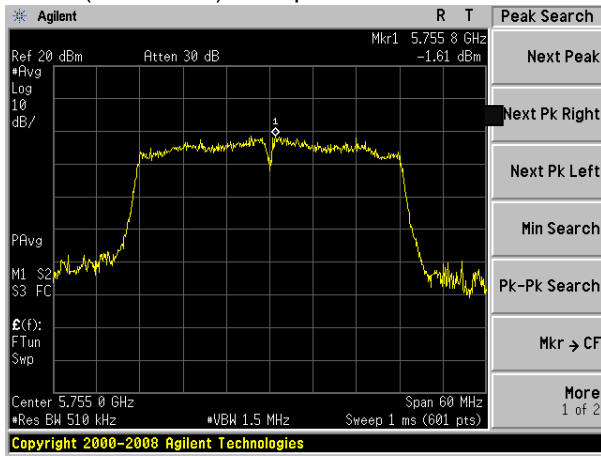

(802.11n40) PSD plot on channel 159

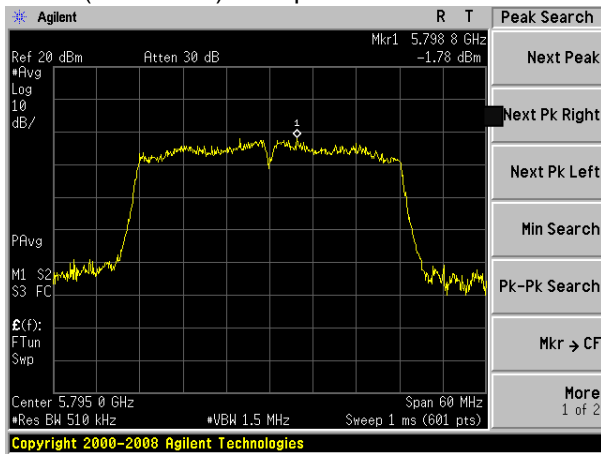

5. 26 DB & 99% EMISSION BANDWIDTH

5.1 APPLIED PROCEDURES / LIMIT

The maximum power spectral density is measured as a conducted emission by direct connection of a calibrated test instrument to the equipment under test. If the device cannot be connected directly, alternative techniques acceptable to the Commission may be used. Measurements in the 5.725-5.85 GHz band are made over a reference bandwidth of 500 kHz or the 26 dB emission bandwidth of the device, whichever is less. Measurements in the 5.15-5.25 GHz, 5.25-5.35 GHz, and the 5.47-5.725 GHz bands are made over a bandwidth of 1 MHz or the 26 dB emission bandwidth of the device, whichever is less. A narrower resolution bandwidth can be used, provided that the measured power is integrated over the full reference bandwidth.

5.2 TEST PROCEDURE

- a) Set RBW = approximately 1% of the emission bandwidth.
- b) Set the VBW > RBW.
- c) Detector = Peak.
- d) Trace mode = max hold.
- e) Measure the maximum width of the emission that is 26 dB down from the maximum of the emission. Compare this with the RBW setting of the analyzer. Readjust RBW and repeat measurement as needed until the RBW/EBW ratio is approximately 1%.

The following procedure shall be used for measuring (99 %) power bandwidth:

1. Set center frequency to the nominal EUT channel center frequency.
2. Set span = 1.5 times to 5.0 times the OBW.
3. Set RBW = 1 % to 5 % of the OBW
4. Set VBW $\geq 3 \cdot$ RBW
5. Video averaging is not permitted. Where practical, a sample detection and single sweep mode shall be used. Otherwise, peak detection and max hold mode (until the trace stabilizes) shall be used.
6. Use the 99 % power bandwidth function of the instrument (if available).
7. If the instrument does not have a 99 % power bandwidth function, the trace data points are recovered and directly summed in power units. The recovered amplitude data points, beginning at the lowest frequency, are placed in a running sum until 0.5 % of the total is reached; that frequency is recorded as the lower frequency. The process is repeated until 99.5 % of the total is reached; that frequency is recorded as the upper frequency. The 99% occupied bandwidth is the difference between these two frequencies.

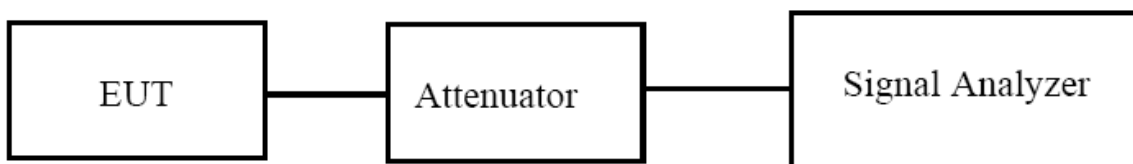

5.3 EUT OPERATION CONDITIONS

The EUT tested system was configured as the statements of 2.4 Unless otherwise a special operating condition is specified in the follows during the testing.

5.4 TEST RESULTS

EUT :	Tablet PC	Model Name :	Indi
Temperature :	25 °C	Relative Humidity :	56%
Pressure :	1012 hPa	Test Voltage :	DC 7.4V
Test Mode :	TX Frequency (5150-5250MHz)		

Mode	Channel	Frequency (MHz)	99% bandwidth (MHz)	26dB bandwidth (MHz)	Result
802.11a	CH36	5180	16.488	18.943	Pass
	CH40	5200	16.517	18.915	Pass
	CH48	5240	16.498	19.006	Pass
802.11 n20	CH36	5180	17.574	19.212	Pass
	CH40	5200	17.592	19.220	Pass
	CH48	5240	17.580	19.083	Pass
802.11 n40	CH 38	5190	35.943	38.784	Pass
	CH 46	5230	35.975	38.451	Pass

(802.11a) -26dB&99% Bandwidth plot on channel 36

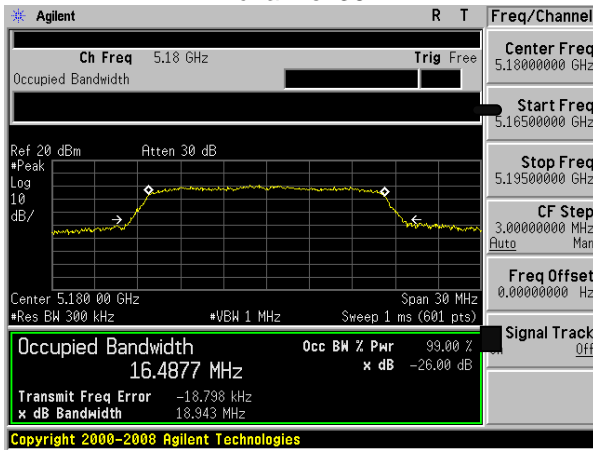

(802.11n20) -26dB&99% Bandwidth plot on channel 36

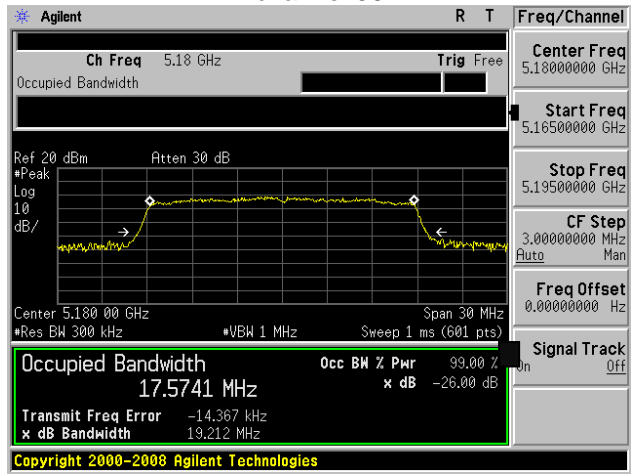

(802.11a) -26dB&99% Bandwidth plot on channel 40

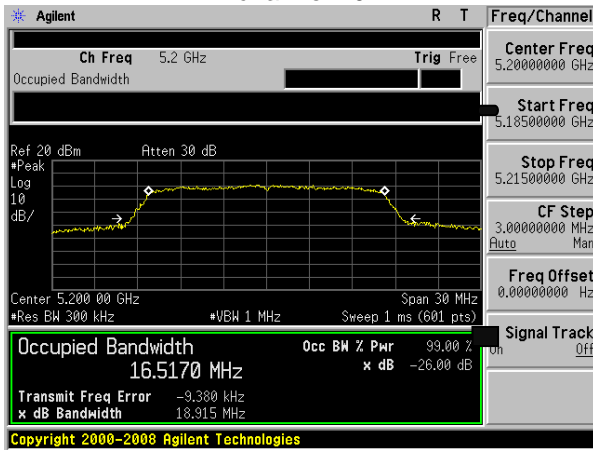

(802.11n20) -26dB&99% Bandwidth plot on channel 40

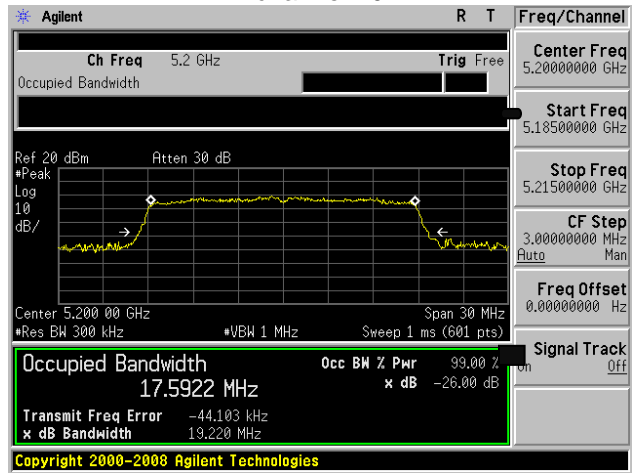

(802.11a) -26dB&99% Bandwidth plot on channel 48

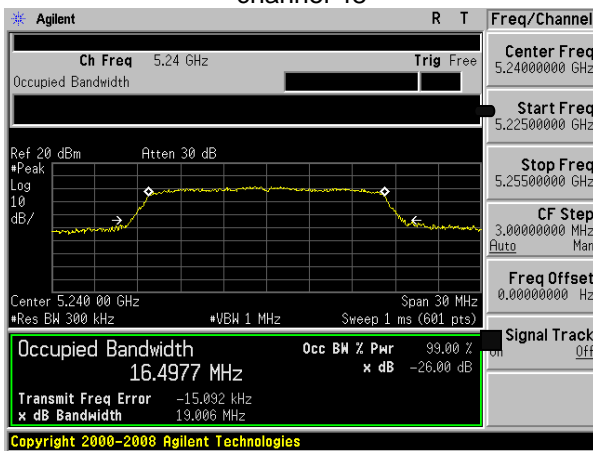

(802.11n20) -26dB&99% Bandwidth plot on channel 48

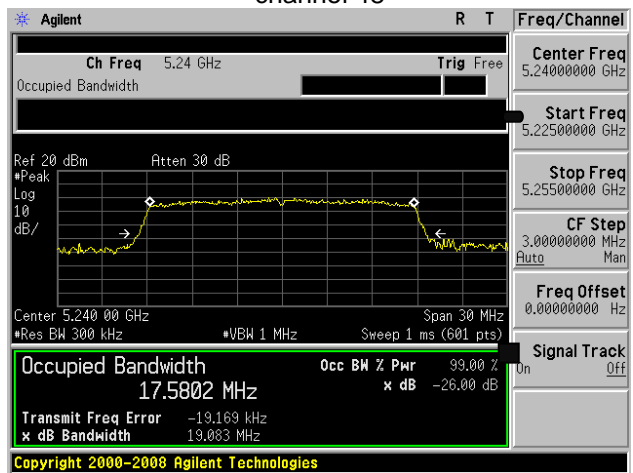

(802.11n40) -26dB&99% Bandwidth plot on channel 38

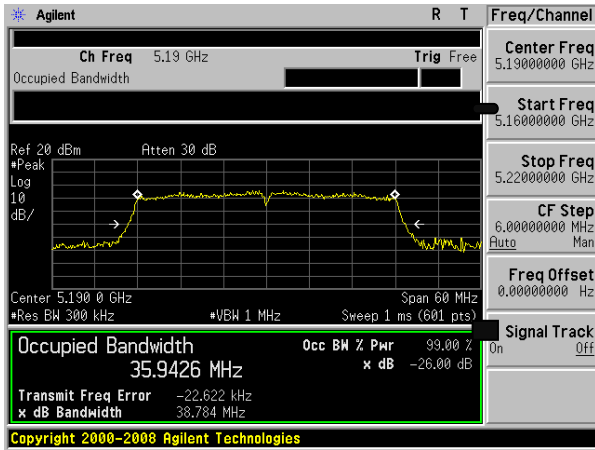

(802.11n40) -26dB&99% Bandwidth plot on channel 46

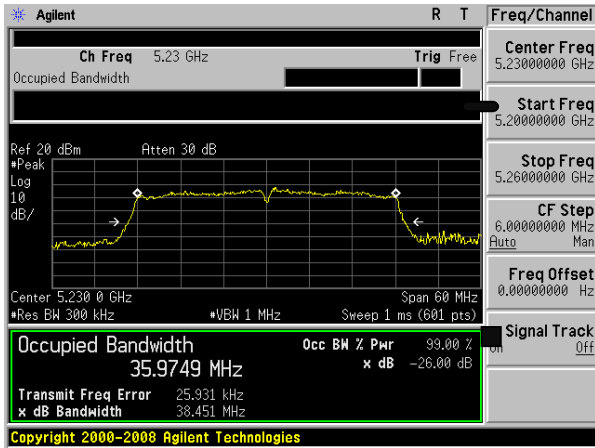

EUT :	Tablet PC	Model Name :	Indi
Temperature :	25 °C	Relative Humidity :	56%
Pressure :	1012 hPa	Test Voltage :	DC 7.4V
Test Mode :	TX Frequency (5745-5850MHz)		

Mode	Channel	Frequency (MHz)	99% bandwidth (MHz)	26dB bandwidth (MHz)	Result
802.11a	CH149	5745	16.459	18.730	Pass
	CH157	5785	16.444	18.768	Pass
	CH165	5825	16.439	18.770	Pass
802.11 n20	CH149	5745	17.518	19.150	Pass
	CH157	5785	17.558	19.076	Pass
	CH165	5825	17.535	19.104	Pass
802.11 n40	CH151	5755	36.974	38.673	Pass
	CH159	5795	35.950	38.670	Pass

(802.11a) -26dB&99% Bandwidth plot on channel 149

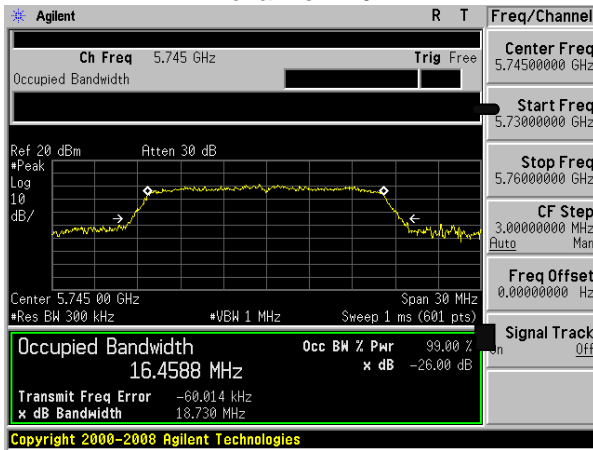

(802.11n20) -26dB&99% Bandwidth plot on channel 149

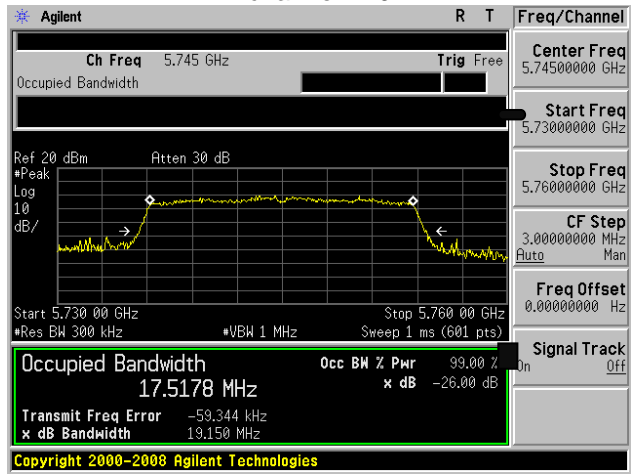

(802.11a) -26dB&99% Bandwidth plot on channel 157

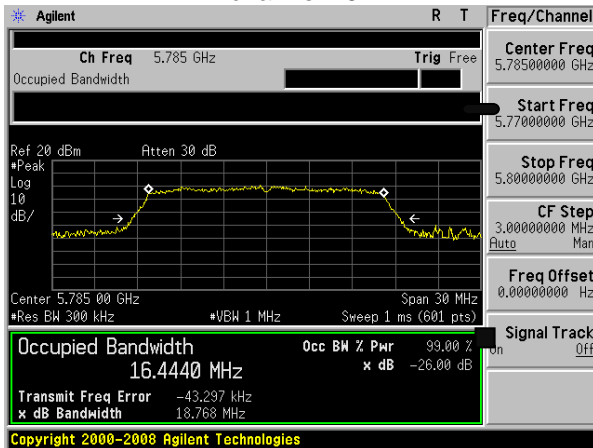

(802.11n20) -26dB&99% Bandwidth plot on channel 157

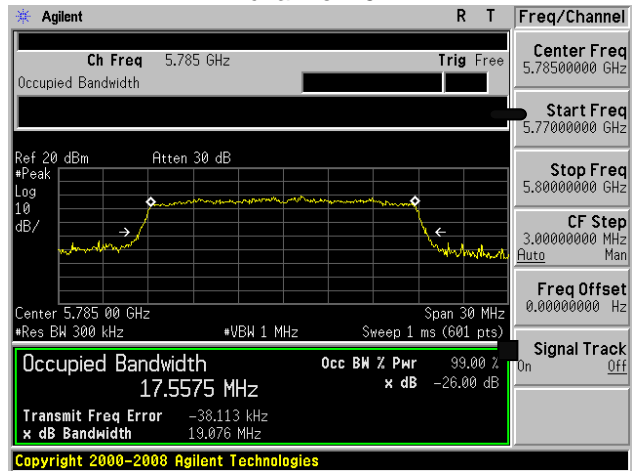

(802.11a) -26dB&99% Bandwidth plot on channel 165

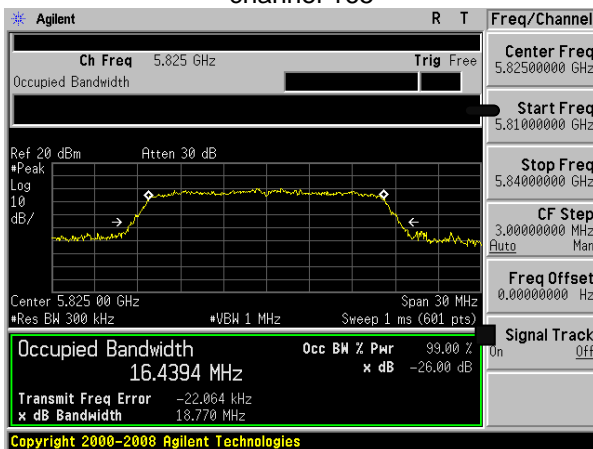

(802.11n20) -26dB&99% Bandwidth plot on channel 165

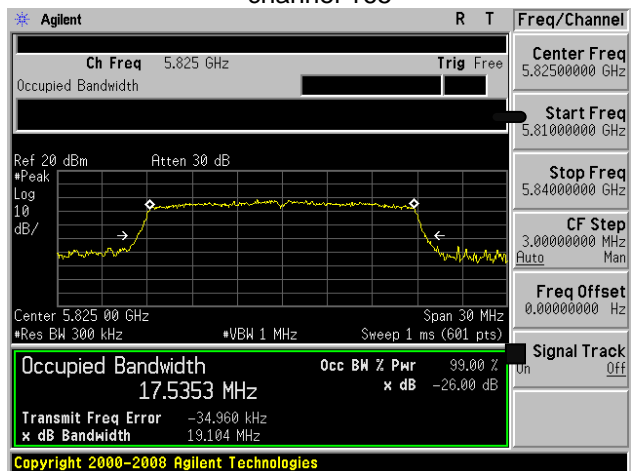

(802.11n40) -26dB&99% Bandwidth plot on channel 151

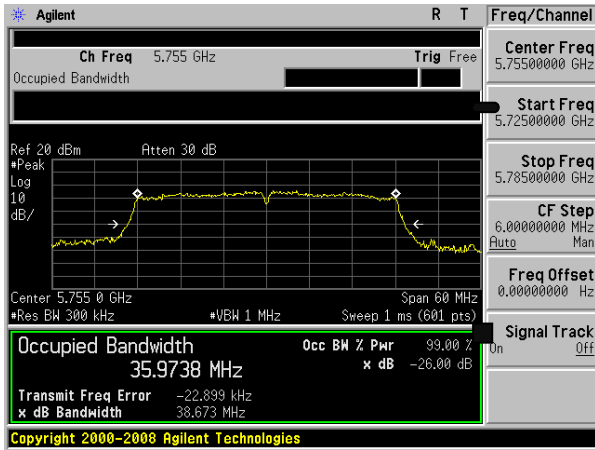

(802.11n40) -26dB&99% Bandwidth plot on channel 159

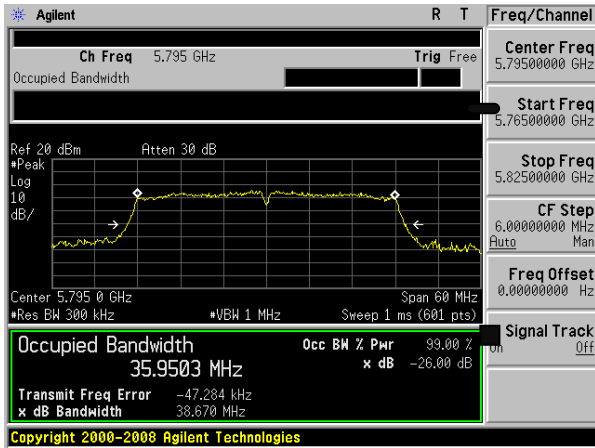

6. MINIMUM 6 DB BANDWIDTH

6.1 APPLIED PROCEDURES / LIMIT

According to FCC §15.407(e)

(e) Within the 5.725-5.85 GHz band, the minimum 6 dB bandwidth of U-NII devices shall be at least 500 kHz.

6.2 TEST PROCEDURE

Section 15.407(e) specifies the minimum 6 dB emission bandwidth of at least 500 KHz for the band 5.715-5.85 GHz. The following procedure shall be used for measuring this bandwidth:

- a) Set RBW = 100 kHz.
- b) Set the video bandwidth (VBW) $\geq 3 \times$ RBW.
- c) Detector = Peak.
- d) Trace mode = max hold.
- e) Sweep = auto couple.
- f) Allow the trace to stabilize.
- g) Measure the maximum width of the emission that is constrained by the frequencies associated with the two outermost amplitude points (upper and lower frequencies) that are attenuated by 6 dB relative to the maximum level measured in the fundamental emission.

6.3 DEVIATION FROM STANDARD

No deviation.

6.4 TEST SETUP

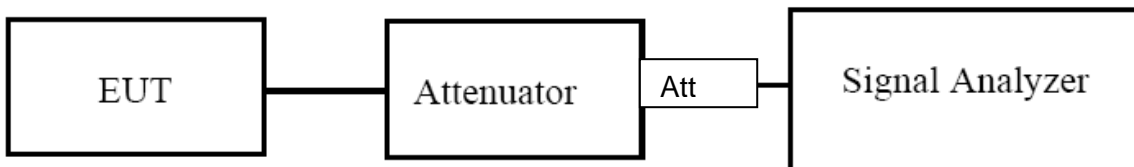

6.5 EUT OPERATION CONDITIONS

The EUT tested system was configured as the statements of 2.4 Unless otherwise a special operating condition is specified in the follows during the testing.

6.6 TEST RESULTS

EUT :	Tablet PC	Model Name :	Indi
Temperature :	25 °C	Relative Humidity :	56%
Pressure :	1012 hPa	Test Voltage :	DC 7.4V
Test Mode :	TX Frequency (5150-5250MHz)		

Mode	Channel	Frequency (MHz)	-6dB bandwidth(MHz)	Result
802.11a	CH36	5180	16.34	Pass
	CH40	5200	15.17	Pass
	CH48	5240	15.77	Pass
802.11 n20	CH36	5180	16.69	Pass
	CH40	5200	16.97	Pass
	CH48	5240	17.02	Pass
802.11 n40	CH 38	5190	35.84	Pass
	CH 46	5230	35.21	Pass

(802.11a) -6dB Bandwidth plot on channel 36

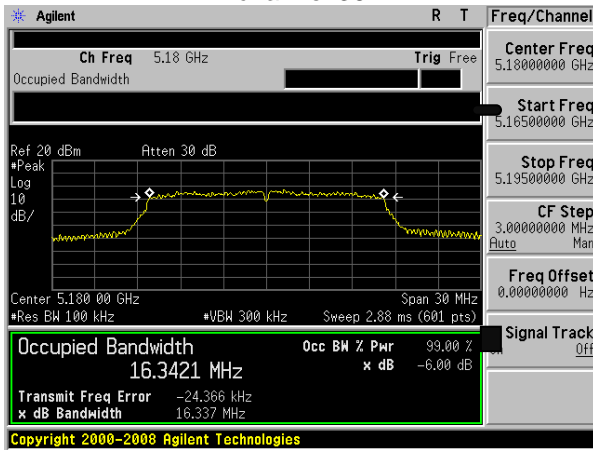

(802.11n20) -6dB Bandwidth plot on channel 36

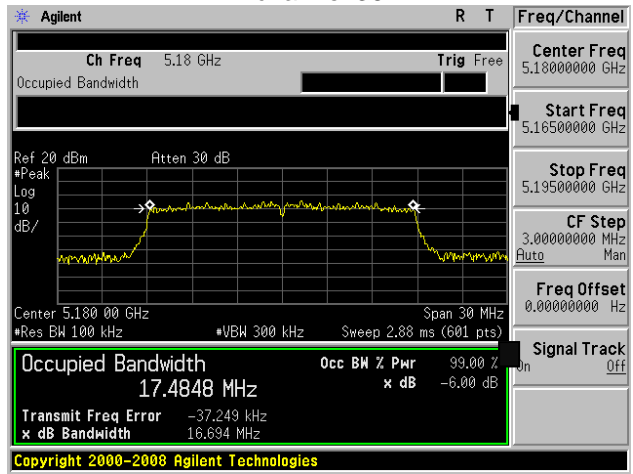

(802.11a) -6dB Bandwidth plot on channel 40

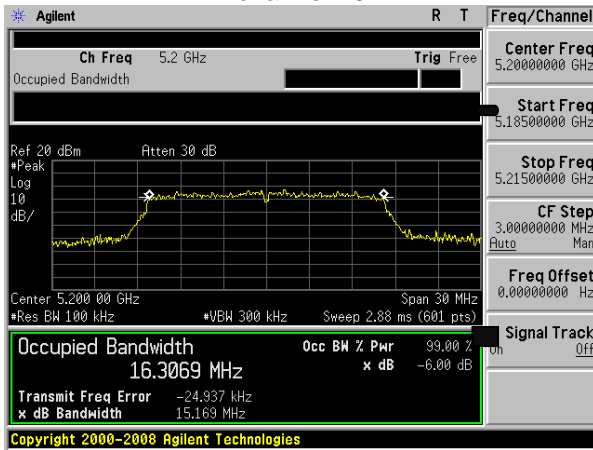

(802.11n20) -6dB Bandwidth plot on channel 40

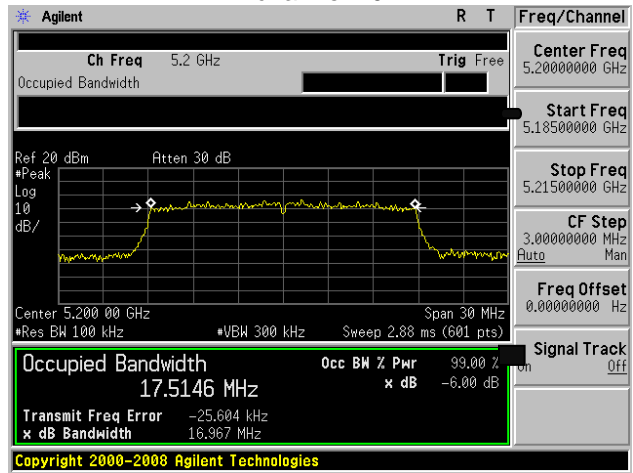

(802.11a) -6dB Bandwidth plot on channel 48

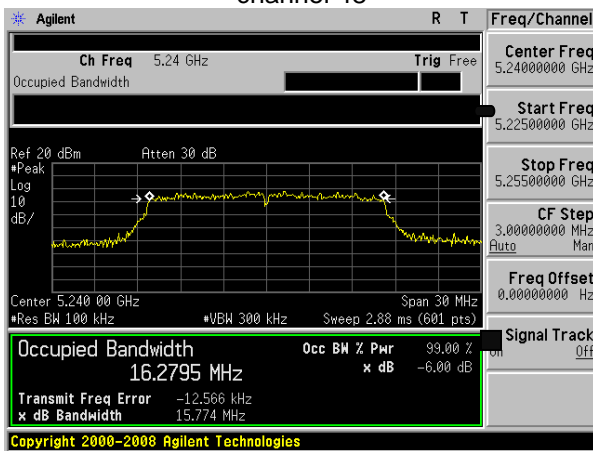

(802.11n20) -6dB Bandwidth plot on channel 48

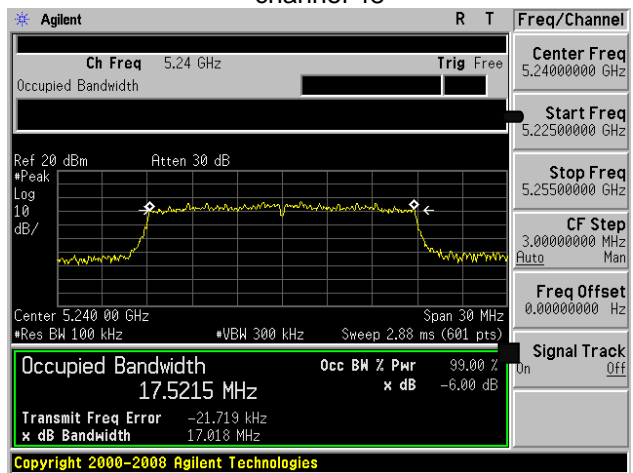

(802.11n40) -6dB Bandwidth plot on channel 38

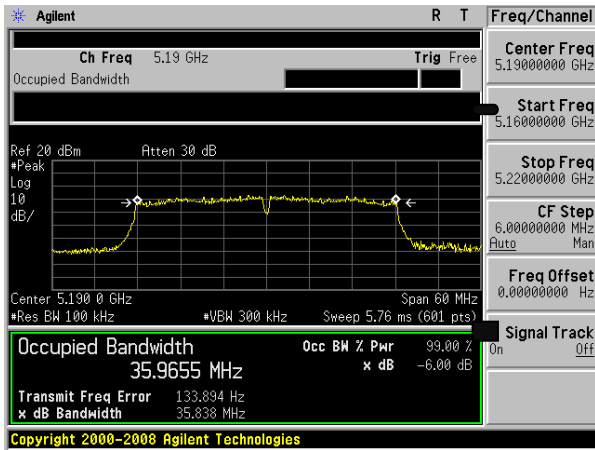

(802.11n40) -6dB Bandwidth plot on channel 46

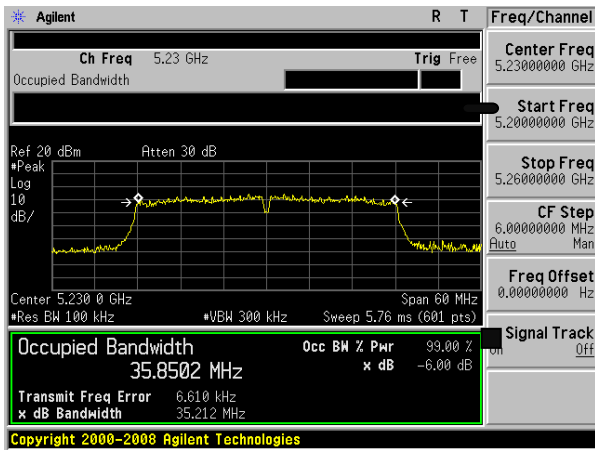

EUT :	Tablet PC	Model Name :	Indi
Temperature :	25 °C	Relative Humidity :	60%
Pressure :	1012 hPa	Test Voltage :	DC 7.4V
Test Mode :	TX (5G) Mode Frequency (5725-5850MHz)		

Mode	Channel	Frequency (MHz)	-6dB bandwidth(MHz)	Limit (KHz)	Result
802.11a	149	5745	15.73	500	Pass
	157	5785	15.41	500	Pass
	165	5825	15.97	500	Pass
802.11 n20	149	5745	16.63	500	Pass
	157	5785	16.27	500	Pass
	165	5825	15.72	500	Pass
802.11 n40	151	5755	35.22	500	Pass
	159	5795	35.22	500	Pass

(802.11a) -6dB Bandwidth plot on channel 149

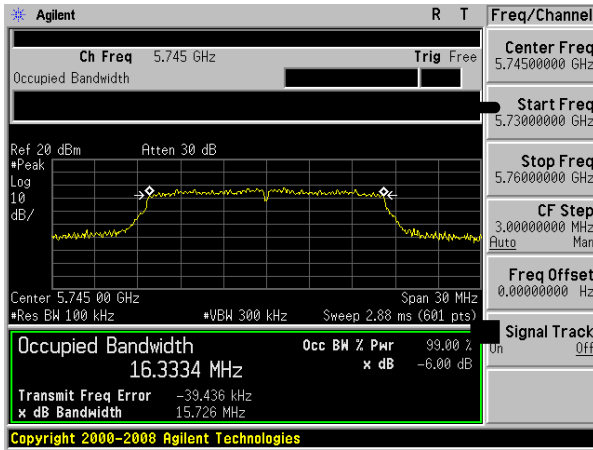

(802.11n20) -6dB Bandwidth plot on channel 149

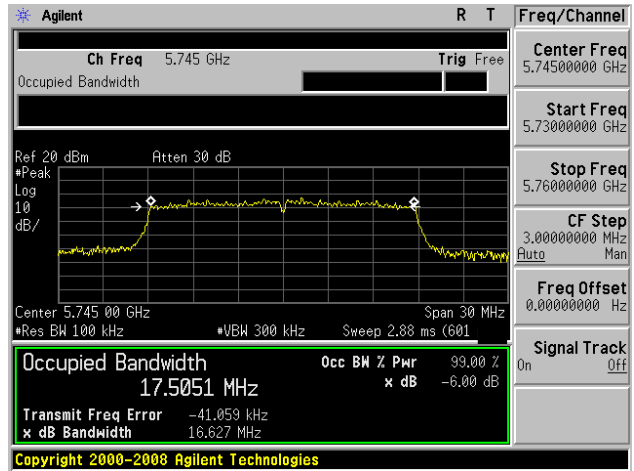

(802.11a) -6dB Bandwidth plot on channel 157

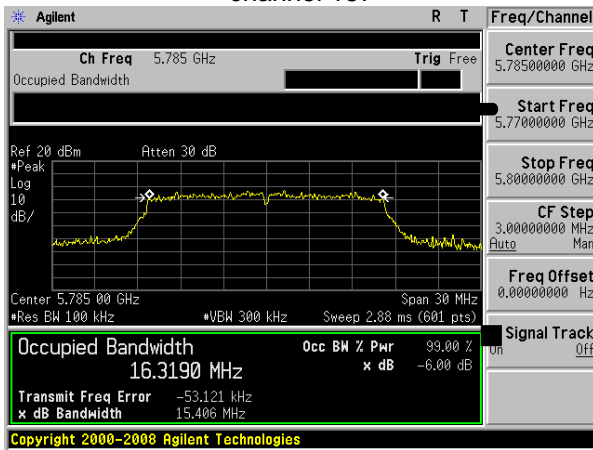

(802.11n20) -6dB Bandwidth plot on channel 157

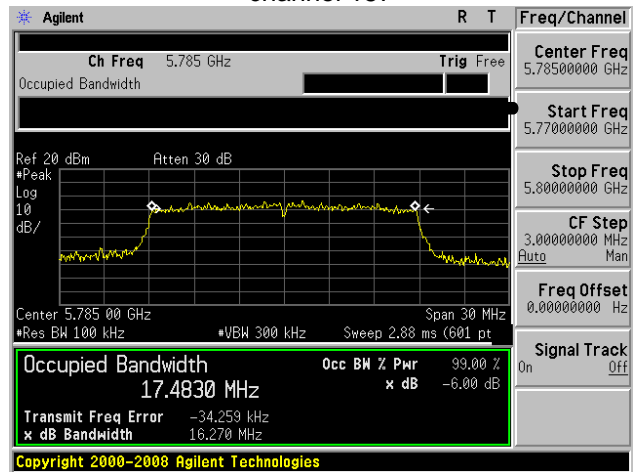

(802.11a) -6dB Bandwidth plot on channel 165

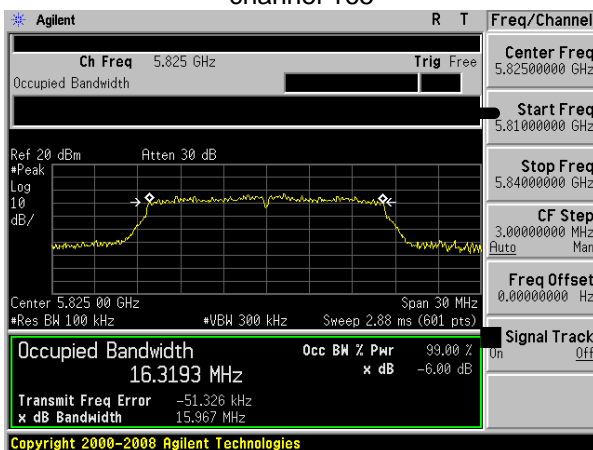

(802.11n20) -6dB Bandwidth plot on channel 165

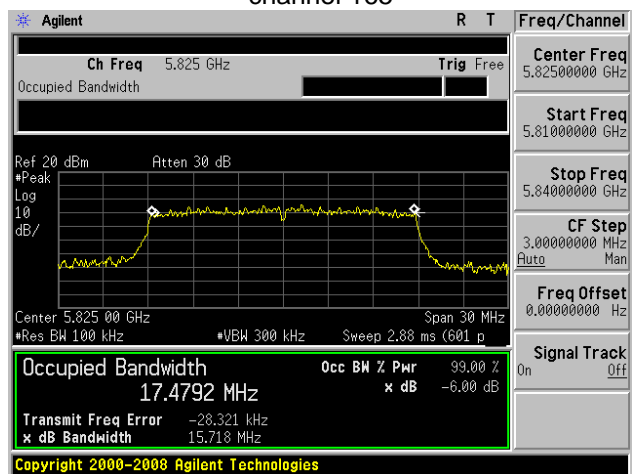

(802.11n40) -6dB Bandwidth plot on channel 151

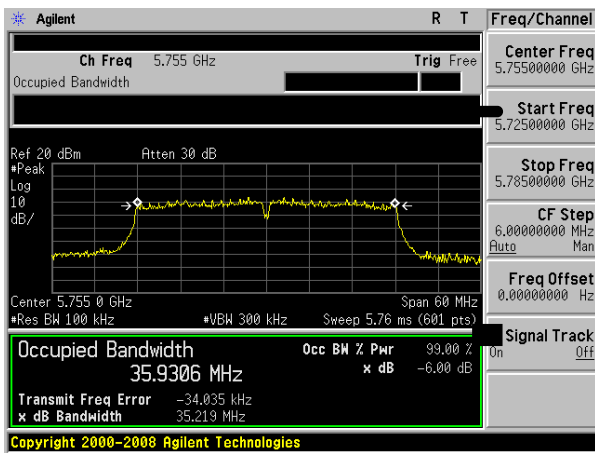

(802.11n40) -6dB Bandwidth plot on channel 159

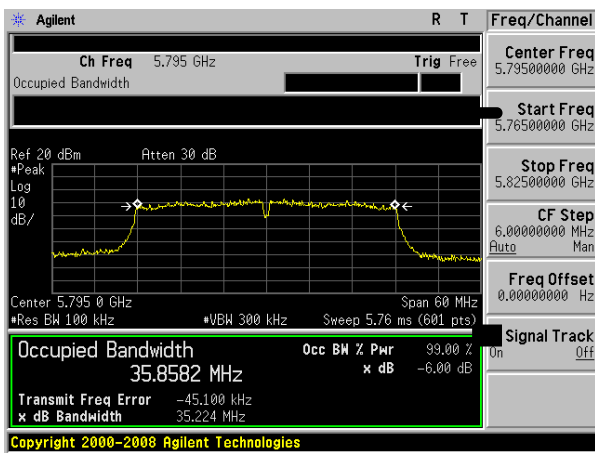

7. MAXIMUM CONDUCTED OUTPUT POWER

7.1 PPLIED PROCEDURES / LIMIT

According to FCC §15.407

According to FCC §15.407

The maximum conducted output power should not exceed:

Frequency Band(MHz)	Limit
5150~5250	250mW
5725~5850	1W

The maximum e.i.r.p should not exceed:

Frequency Band(MHz)	Limit
5150~5250	200mW or 10dBm +10logB whichever is less
5725~5850	N/A

Note: Where “B” is the 99% emission bandwidth in MHz

7.2 TEST PROCEDURE

· Maximum conducted output power may be measured using a spectrum analyzer/EMI receiver or an RF power meter.

1. Device Configuration

If possible, configure or modify the operation of the EUT so that it transmits continuously at its maximum power control level (see section II.B.).

a) The intent is to test at 100 percent duty cycle; however a small reduction in duty cycle (to no lower than 98 percent) is permitted if required by the EUT for amplitude control purposes. Manufacturers are expected to provide software to the test lab to permit such continuous operation.

b) If continuous transmission (or at least 98 percent duty cycle) cannot be achieved due to hardware limitations (e.g., overheating), the EUT shall be operated at its maximum power control level with the transmit duration as long as possible and the duty cycle as high as possible.

2. Measurement using a Spectrum Analyzer or EMI Receiver (SA)

Measurement of maximum conducted output power using a spectrum analyzer requires integrating the spectrum across a frequency span that encompasses, at a minimum, either the EBW or the 99-percent occupied bandwidth of the signal.¹ However, the EBW must be used to determine bandwidth dependent limits on maximum conducted output power in accordance with § 15.407(a).

a) The test method shall be selected as follows: (i) Method SA-1 or SA-1 Alternative (averaging with the EUT transmitting at full power throughout each sweep) shall be applied if either of the following conditions can be satisfied:

- The EUT transmits continuously (or with a duty cycle ≥ 98 percent).
- Sweep triggering or gating can be implemented in a way that the device transmits at the maximum power control level throughout the duration of each of the instrument sweeps to be averaged. This condition can generally be achieved by triggering the instrument's sweep if the duration of the sweep (with the analyzer configured as in Method SA-1, below) is equal to or shorter than the duration T of each transmission from the EUT and if those transmissions exhibit full power throughout their durations.

(ii) Method SA-2 or SA-2 Alternative (averaging across on and off times of the EUT transmissions, followed by duty cycle correction) shall be applied if the conditions of (i) cannot be achieved and the transmissions exhibit a constant duty cycle during the measurement duration. Duty cycle will be considered to be constant if variations are less than ± 2 percent.

(iii) Method SA-3 (RMS detection with max hold) or SA-3 Alternative (reduced VBW with max hold) shall be applied if the conditions of (i) and (ii) cannot be achieved.

b) Method SA-1 (trace averaging with the EUT transmitting at full power throughout each sweep): (i) Set span to encompass the entire emission bandwidth (EBW) (or, alternatively, the entire 99% occupied bandwidth) of the signal.

(ii) Set RBW = 1 MHz.

(iii) Set VBW ≥ 3 MHz.

(iv) Number of points in sweep ≥ 2 Span / RBW. (This ensures that bin-to-bin spacing is \leq RBW/2, so that narrowband signals are not lost between frequency bins.)

(v) Sweep time = auto.

(vi) Detector = RMS (i.e., power averaging), if available. Otherwise, use sample detector mode.

(vii) If transmit duty cycle < 98 percent, use a video trigger with the trigger level set to enable triggering only on full power pulses. Transmitter must operate at maximum power control level for the entire duration of every sweep. If the EUT transmits continuously (i.e., with no off intervals) or at duty cycle ≥ 98 percent, and if each transmission is entirely at the maximum power control level, then the trigger shall be set to "free run".

(viii) Trace average at least 100 traces in power averaging (i.e., RMS) mode.

(ix) Compute power by integrating the spectrum across the EBW (or, alternatively, the entire 99% occupied bandwidth) of the signal using the instrument's band power measurement function with band limits set equal to the EBW (or occupied bandwidth) band edges. If the instrument does not have a band power function, sum the spectrum

7.3 DEVIATION FROM STANDARD

No deviation.

7.4 TEST SETUP

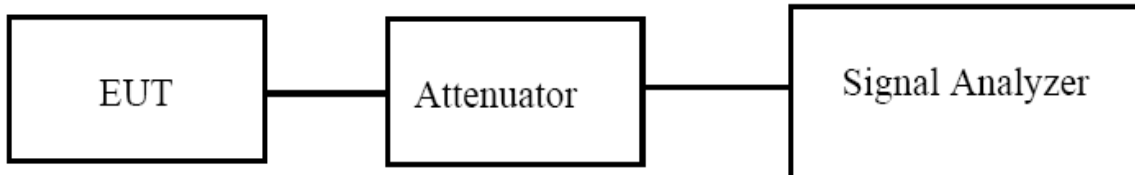

7.5 EUT OPERATION CONDITIONS

The EUT tested system was configured as the statements of 2.4 Unless otherwise a special operating condition is specified in the follows during the testing.

7.6 TEST RESULTS

EUT :	Tablet PC	Model Name :	Indi
Temperature :	25 °C	Relative Humidity :	60%
Pressure :	1012 hPa	Test Voltage :	DC 7.4V
Test Mode :	TX (5G) Mode Frequency (5150-5250MHz)		

Test Channel	Frequency (MHz)	Maximum output power. Antenna port (AV)	LIMIT	Result
		(dBm)		
		TX 802.11a Mode		
CH36	5180	8.8	23.98	Pass
CH40	5200	9.2	23.98	Pass
CH48	5240	10.0	23.98	Pass
TX 802.11 n20M Mode				
CH36	5180	7.6	21.42	Pass
CH40	5200	8.1	21.42	Pass
CH48	5240	8.9	21.42	Pass
TX 802.11 n40M Mode				
CH38	5190	7.4	21.42	Pass
CH46	5230	8.2	21.42	Pass

EUT :	Tablet PC	Model Name :	Indi
Temperature :	25 °C	Relative Humidity :	60%
Pressure :	1012 hPa	Test Voltage :	DC 7.4V
Test Mode :	TX (5G) Mode Frequency (5725-5850MHz)		

Test Channel	Frequency (MHz)	Maximum output power. Antenna port (AV)	LIMIT	Result
		(dBm)		
		TX 802.11a Mode		
CH 149	5745	9.2	30	Pass
CH 157	5785	8.5	30	Pass
CH 165	5825	7.9	30	Pass
TX 802.11 n20M Mode				
CH 149	5745	8.0	27.44	Pass
CH 157	5785	7.3	27.44	Pass
CH 165	5825	6.8	27.44	Pass
TX 802.11 n40M Mode				
CH 151	5755	7.2	27.44	Pass
CH 159	5795	6.5	27.44	Pass

8. OUT OF BAND EMISSIONS

8.1 APPLICABLE STANDARD

According to FCC §15.407(b)

Undesirable emission limits. Except as shown in paragraph (b)(7) of this section, the maximum emissions outside of the frequency bands of operation shall be attenuated in accordance with the following limits:

(1) For transmitters operating in the 5.15-5.25 GHz band: All emissions outside of the 5.15-5.35 GHz band shall not exceed an e.i.r.p. of -27 dBm/MHz.

(2) For transmitters operating in the 5.725-5.85 GHz band: All emissions shall be limited to a level of -27 dBm/MHz at 75 MHz or more above or below the band edge increasing linearly to 10 dBm/MHz at 25 MHz above or below the band edge, and from 25 MHz above or below the band edge increasing linearly to a level of 15.6 dBm/MHz at 5 MHz above or below the band edge, and from 5 MHz above or below the band edge increasing linearly to a level of 27 dBm/MHz at the band edge.

8.2 TEST PROCEDURE

1. Check the calibration of the measuring instrument using either an internal calibrator or a known signal from an external generator.
2. Position the EUT without connection to measurement instrument. Turn on the EUT and connect its antenna terminal to measurement instrument via a low loss cable. Then set it to any one measured frequency within its operating range, and make sure the instrument is operated in its linear range.
3. Set RBW of spectrum analyzer to 1 MHz with a convenient frequency span.
4. Measure the highest amplitude appearing on spectral display and set it as a reference level. Plot the graph with marking the highest point and edge frequency.
5. Repeat above procedures until all measured frequencies were complete.

8.3 DEVIATION FROM STANDARD

No deviation.

8.4 TEST SETUP



8.5 EUT OPERATION CONDITIONS

The EUT tested system was configured as the statements of 2.4 Unless otherwise a special operating condition is specified in the follows during the testing.

8.6 TEST RESULTS

EUT :	Tablet PC	Model Name :	Indi
Temperature :	25 °C	Relative Humidity :	56%
Pressure :	1012 hPa	Test Voltage :	DC 7.4V

5.2G

5.15~5.25 GHz

(802.11a) Band Edge, Left Side

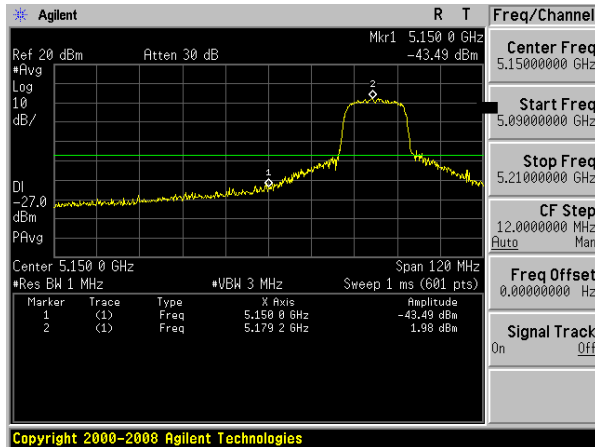

Copyright 2000-2008 Agilent Technologies

(802.11n20) Band Edge, Left Side

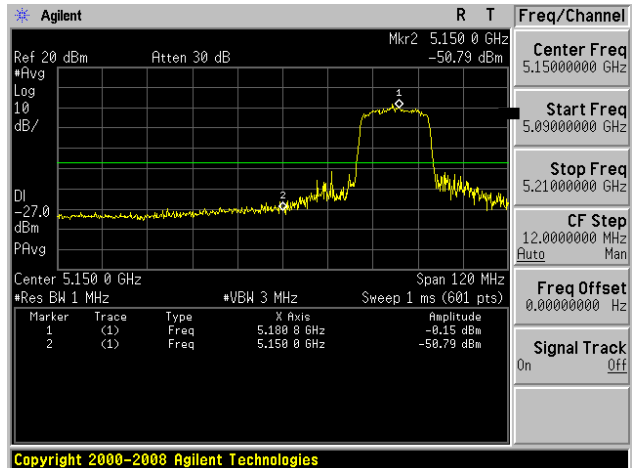

Copyright 2000-2008 Agilent Technologies

(802.11a) Band Edge, Right Side

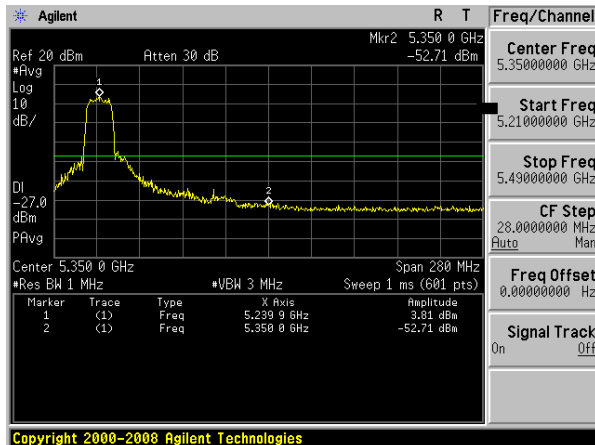

Copyright 2000-2008 Agilent Technologies

(802.11n20) Band Edge, Right Side

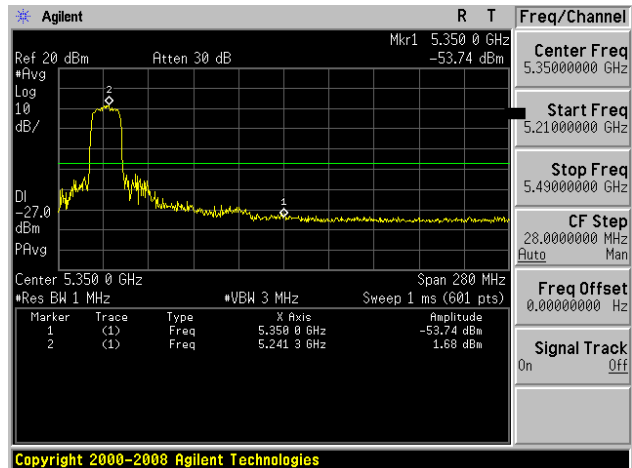

Copyright 2000-2008 Agilent Technologies

5.15~5.25 GHz

(802.11n40) Band Edge, Left Side

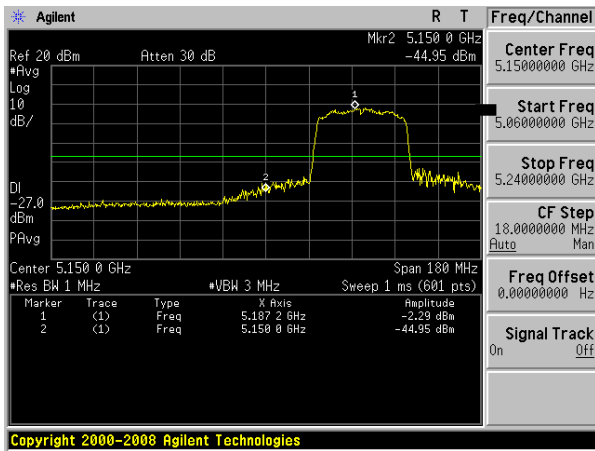

(802.11n40) Band Edge, Right Side

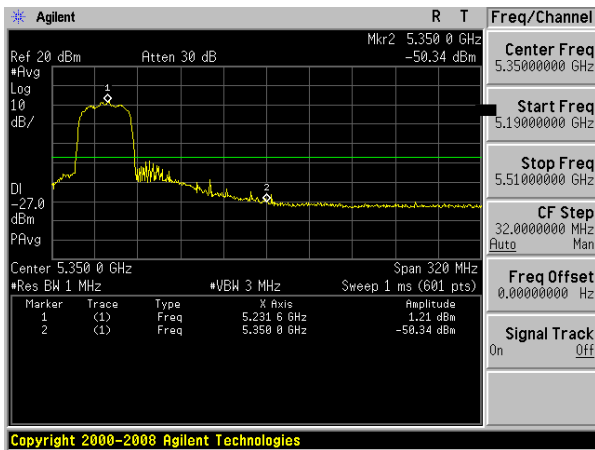

5.8G

5.725-5.85 GHz

(802.11a) Band Edge, Left Side

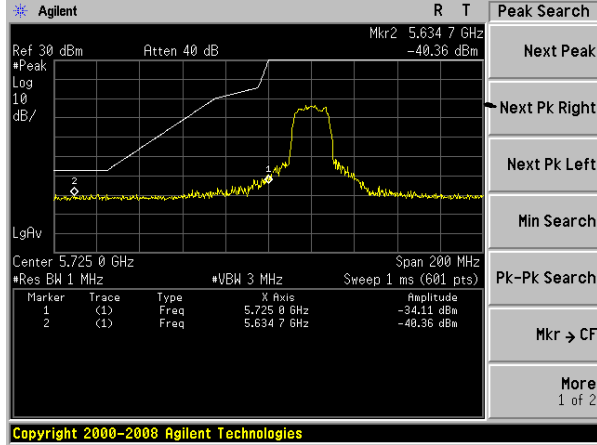

(802.11n20) Band Edge, Left Side

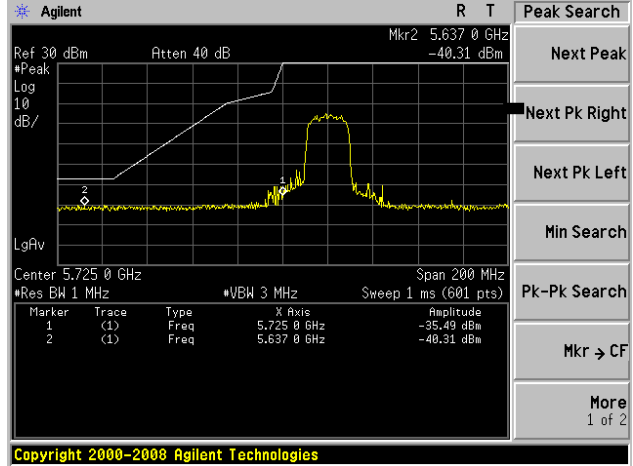

(802.11a) Band Edge, Right Side

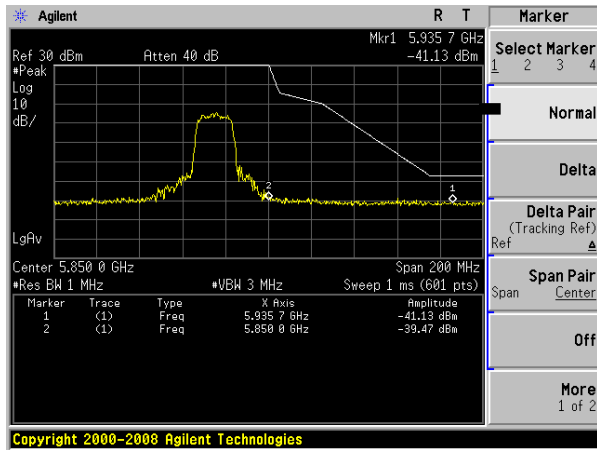

(802.11n20) Band Edge, Right Side

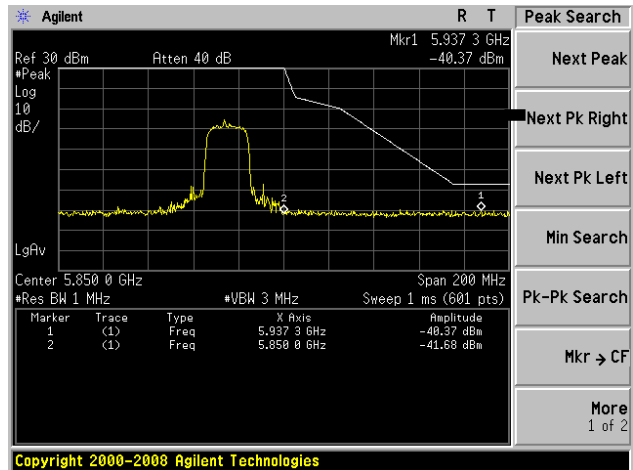

5.725-5.85 GHz

(802.11n40) Band Edge, Left Side

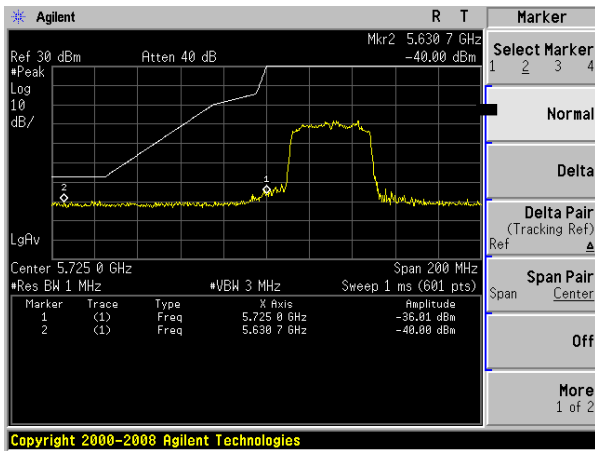

(802.11n40) Band Edge, Right Side

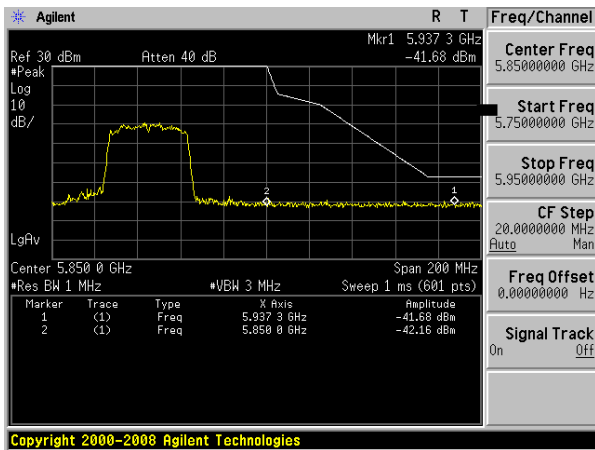

9.SPURIOUS RF CONDUCTED EMISSIONS

9.1 CONFORMANCE LIMIT

1. Below -20dB of the highest emission level in operating band.
2. Fall in the restricted bands listed in section 15.205. The maximum permitted average field strength is listed in section 15.209.

9.2 MEASURING INSTRUMENTS

The Measuring equipment is listed in the section 6.3 of this test report.

9.3 TEST SETUP

Please refer to Section 6.1 of this test report.

9.4 TEST PROCEDURE

The Spurious RF conducted emissions compliance of RF radiated emission should be measured by following the guidance in ANSI C63.10-2013 with respect to maximizing the emission by rotating the EUT, measuring the emission while the EUT is situated in three orthogonal planes (if appropriate), adjusting the measurement antenna height and polarization etc. Set RBW=100kHz and VBW= 300kHz to measure the peak field strength , and measure frequency range from 9kHz to 26.5GHz.

9.5 TEST RESULTS

Remark: The measurement frequency range is from 9kHz to the 10th harmonic of the fundamental frequency. The lowest, middle and highest channels are tested to verify the spurious emissions and band edge measurement data.

5.2G

Test Plot

802.11a on channel 36

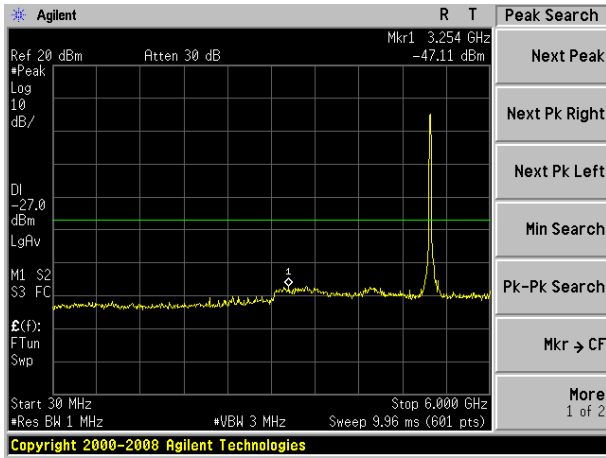

802.11a on channel 40

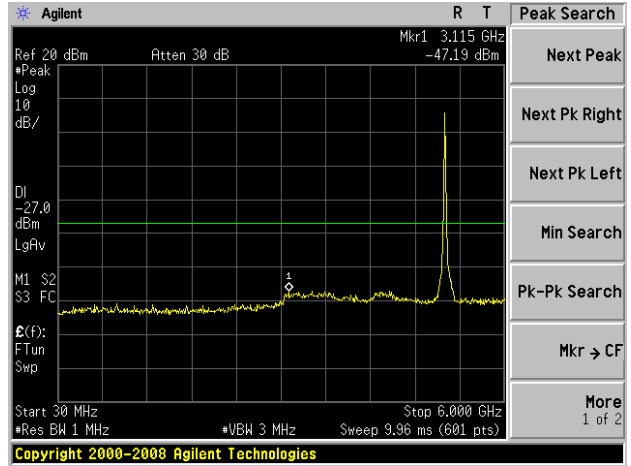

802.11a on channel 36

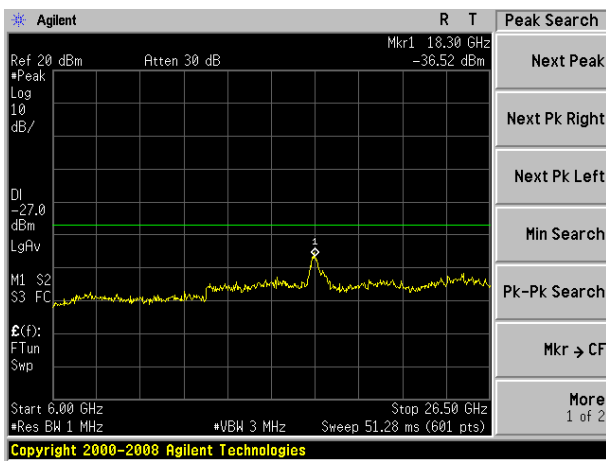

802.11a on channel 40

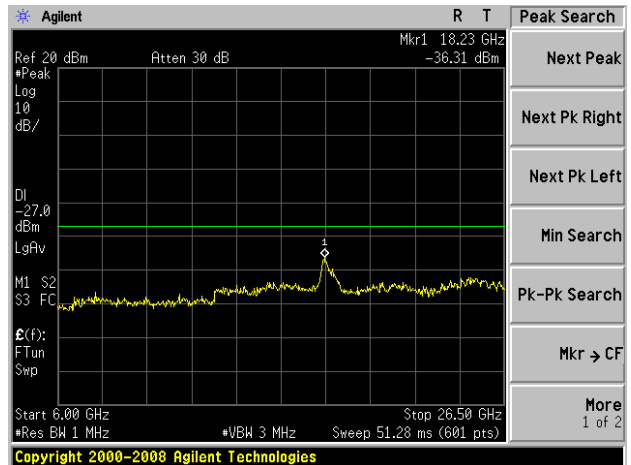

Test Plot

802.11a on channel 48

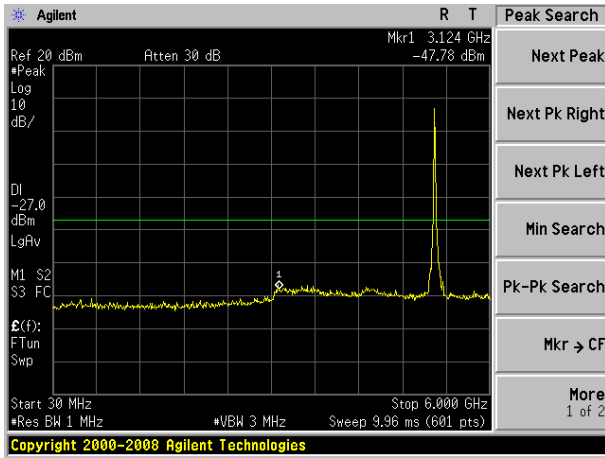

802.11n20 on channel 36

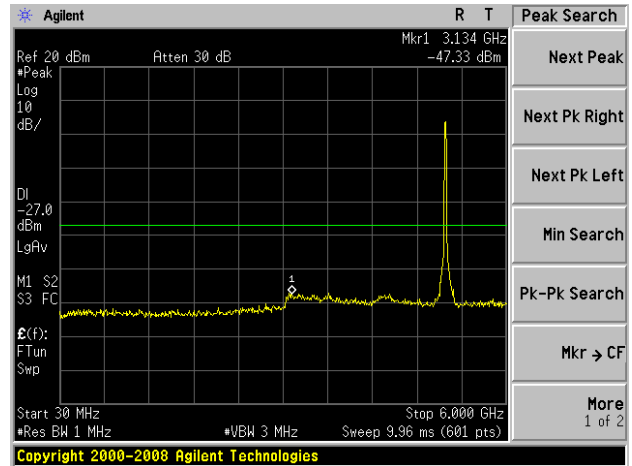

802.11a on channel 48

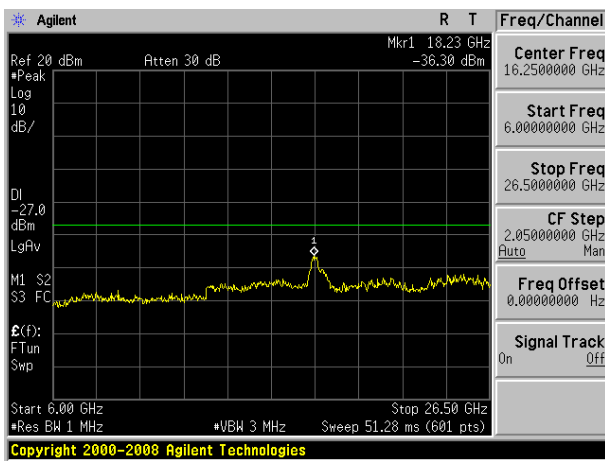

802.11n20 on channel 36

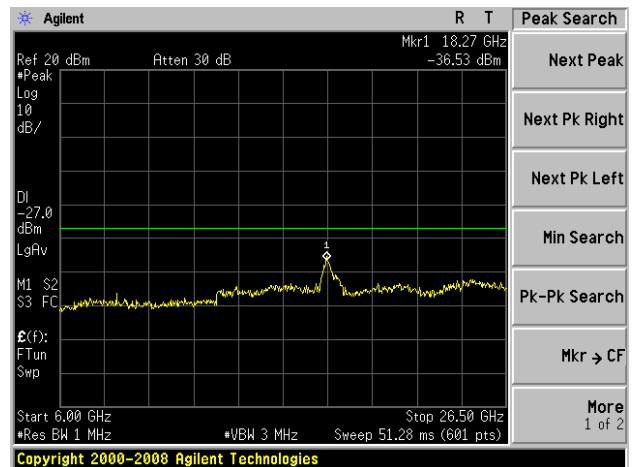

Test Plot

802.11n20 on channel 40

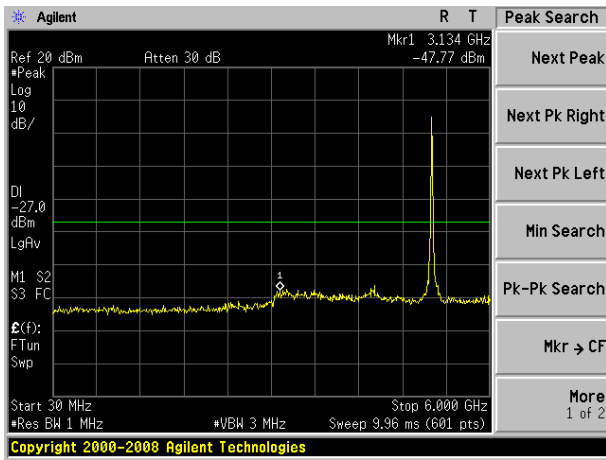

802.11n20 on channel 48

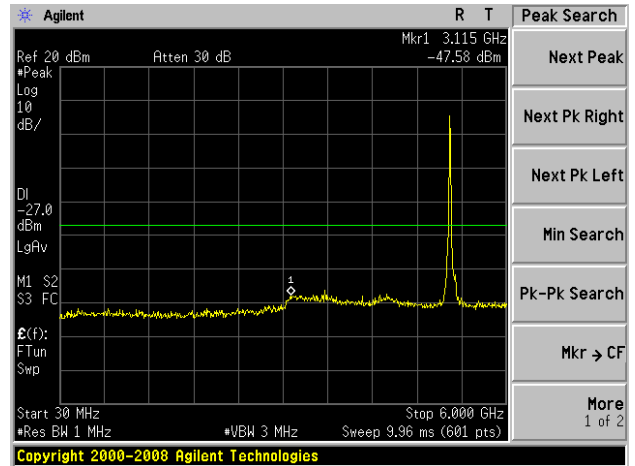

802.11n20 on channel 40

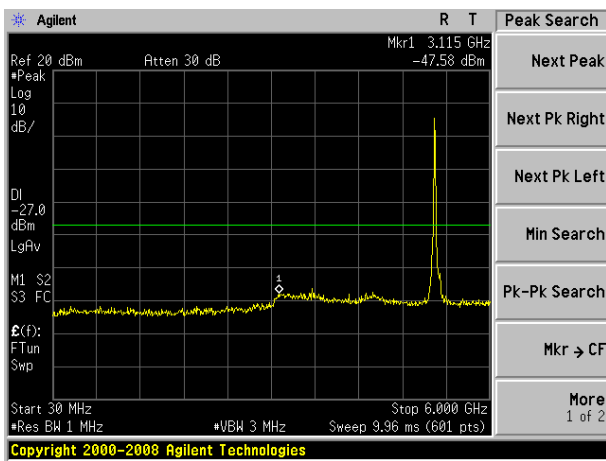

802.11n20 on channel 48

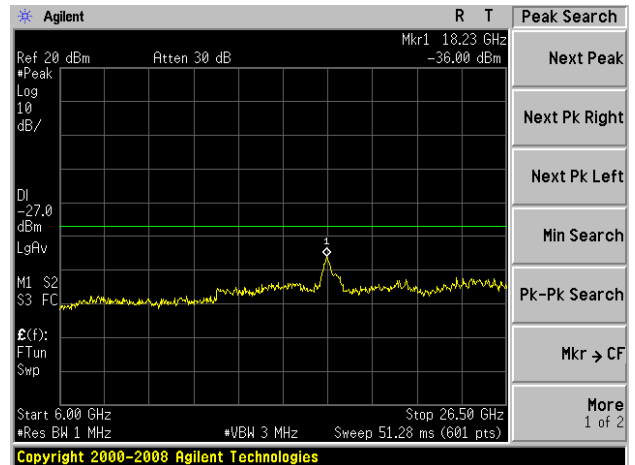

Test Plot

802.11n40 on channel 38

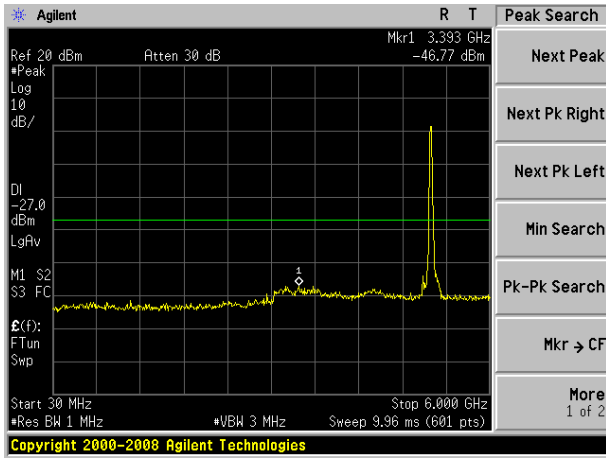

802.11n40 on channel 46

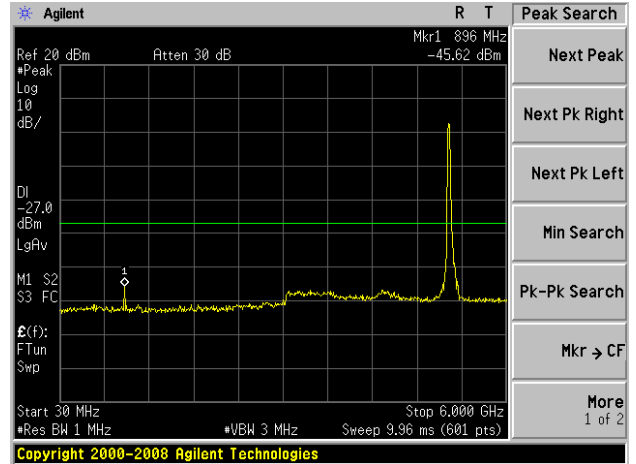

802.11n40 on channel 38

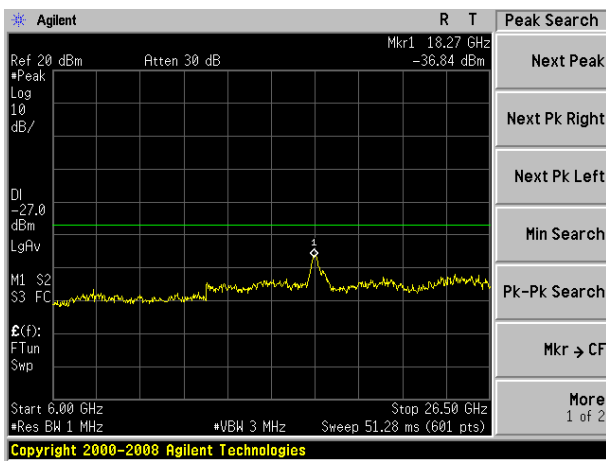

802.11n40 on channel 46

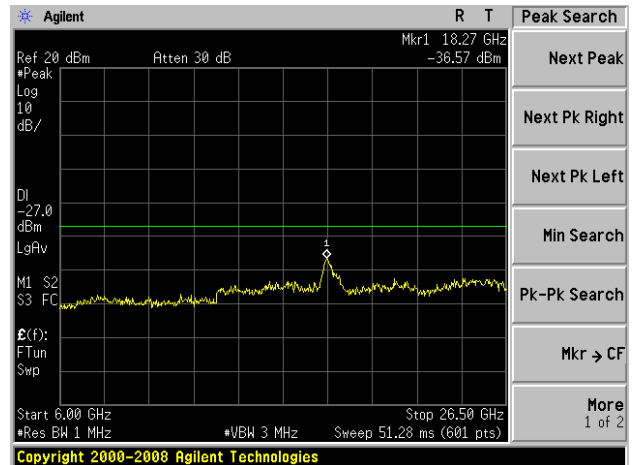

5.8G Test Plot

802.11a on channel 149

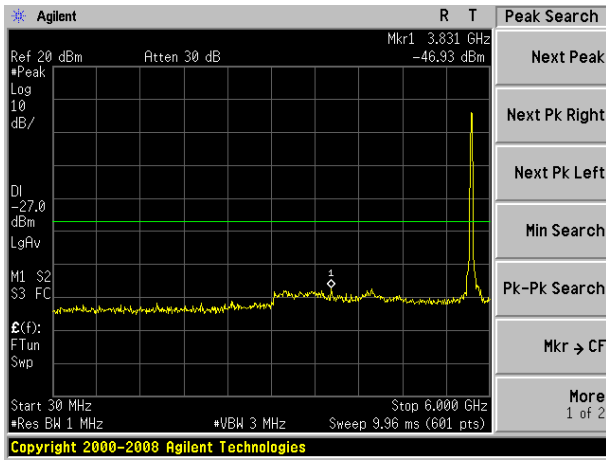

802.11a on channel 157

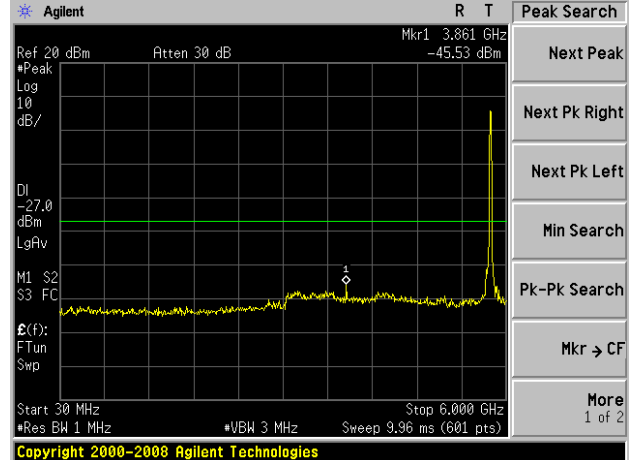

802.11a on channel 149

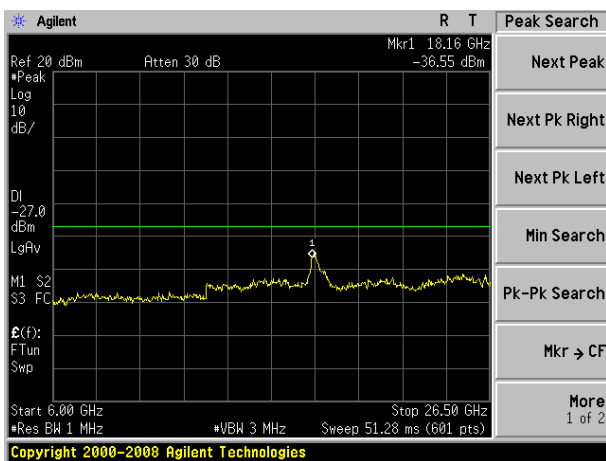

802.11a on channel 157

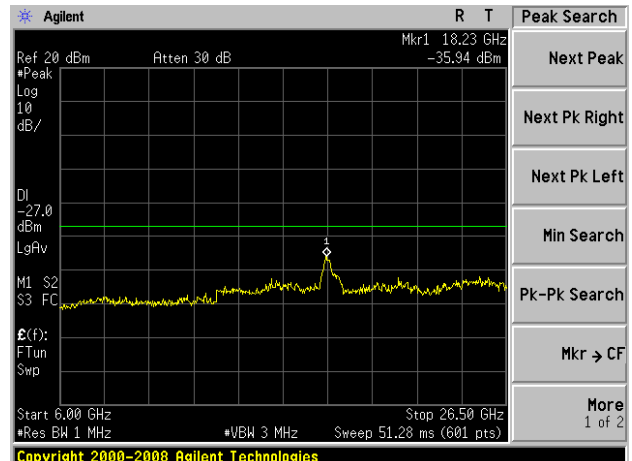

Test Plot

802.11a on channel 165

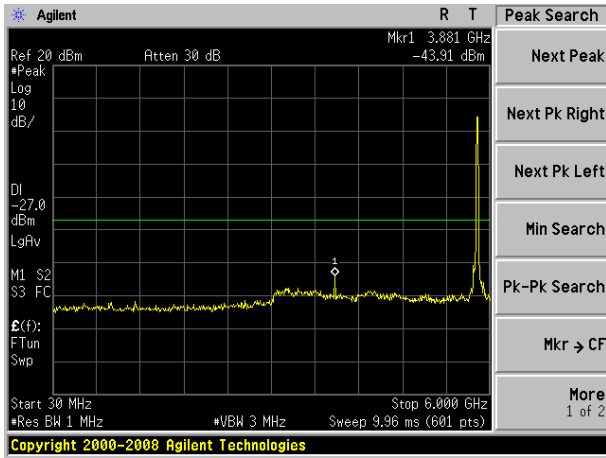

802.11n20 on channel 149

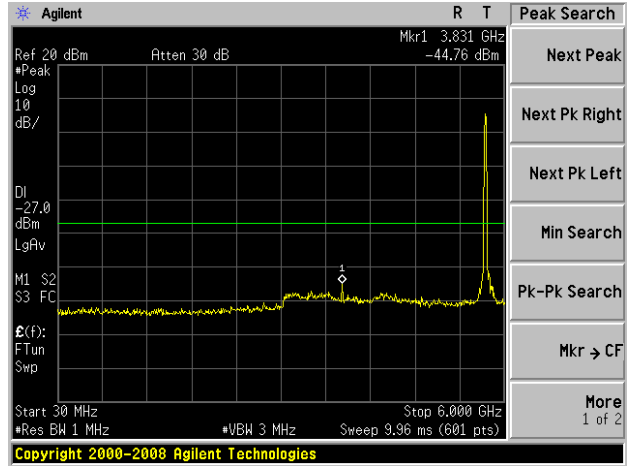

802.11a on channel 165

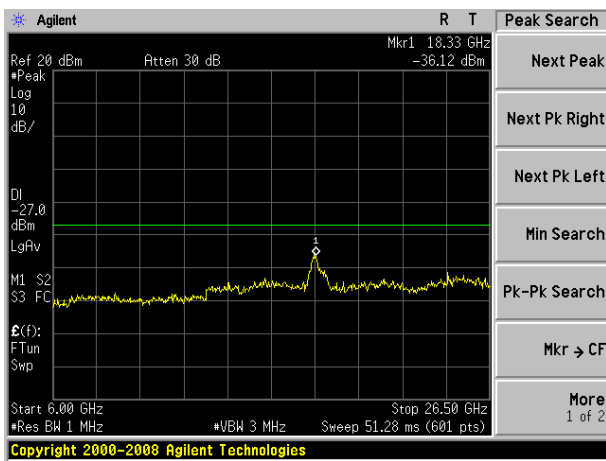

802.11n20 on channel 149

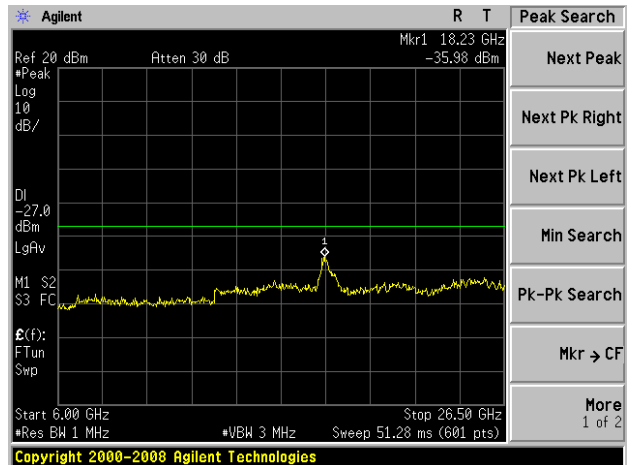

Test Plot

802.11n20 on channel 157

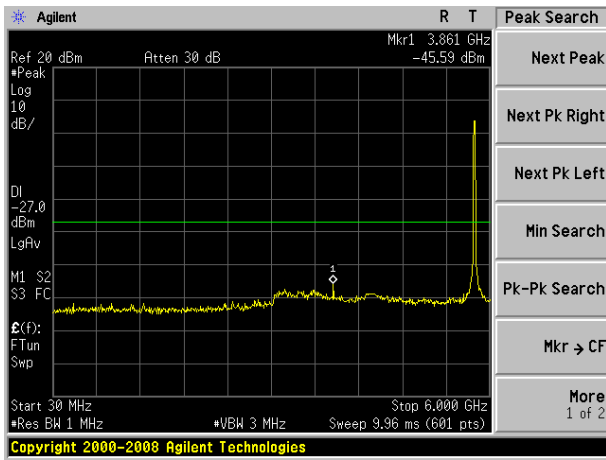

802.11n20 on channel 165

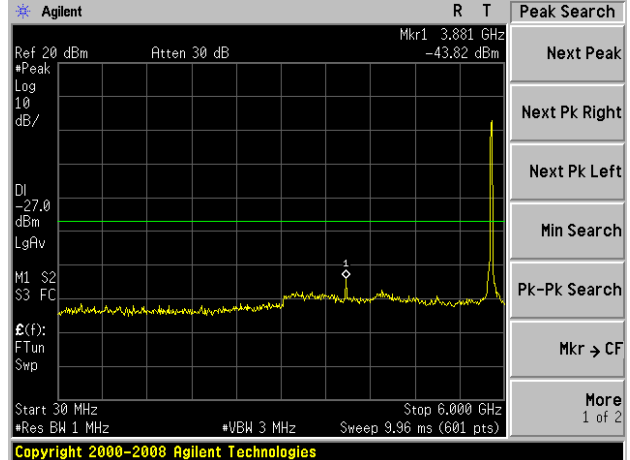

802.11n20 on channel 157

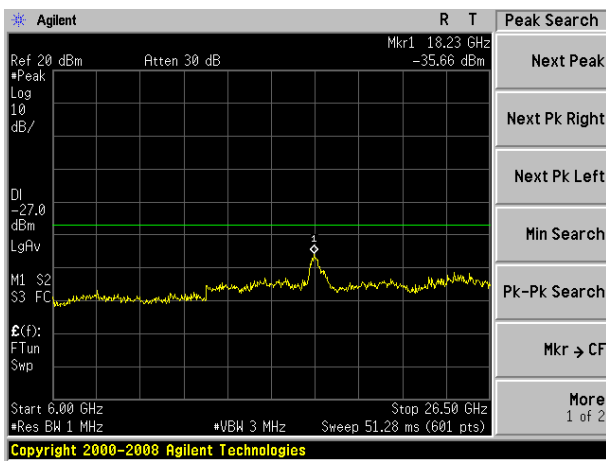

802.11n20 on channel 165

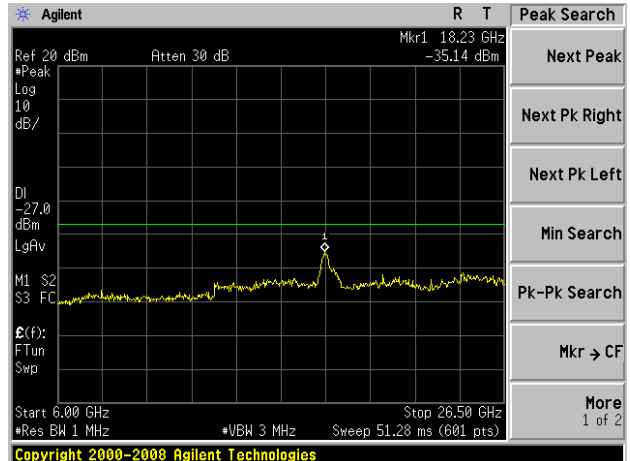

Test Plot

802.11n40 on channel 151

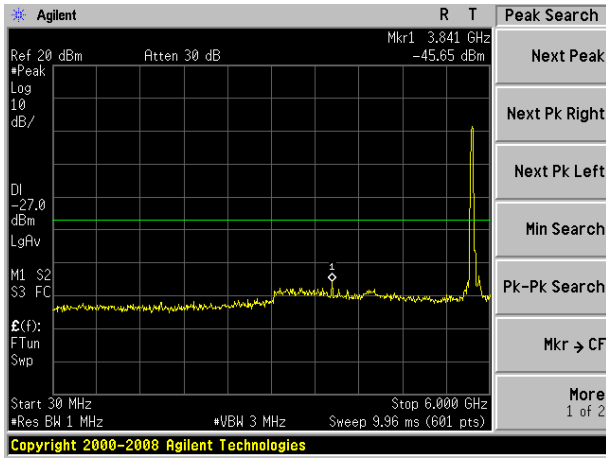

802.11n40 on channel 159

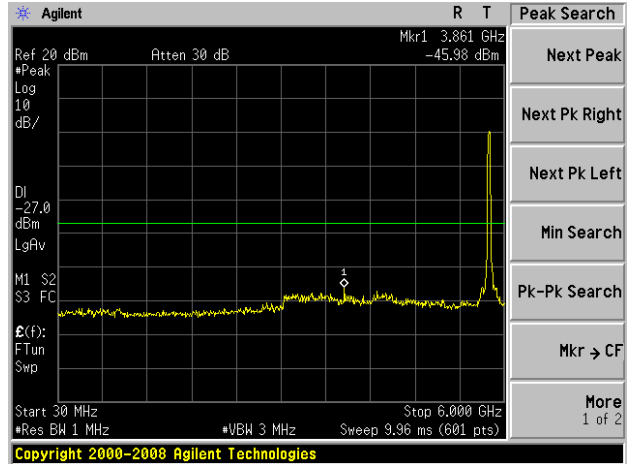

802.11n40 on channel 151

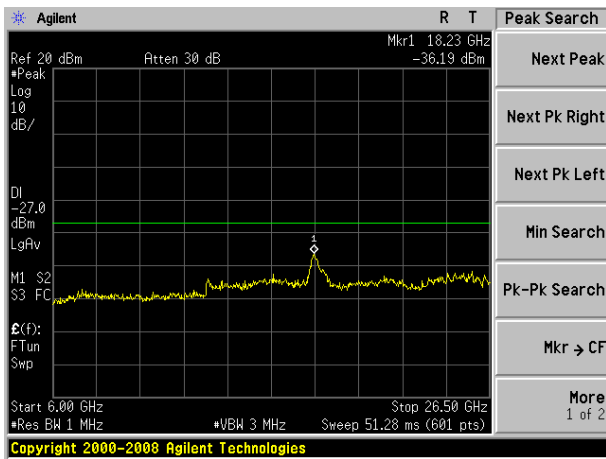

802.11n40 on channel 159

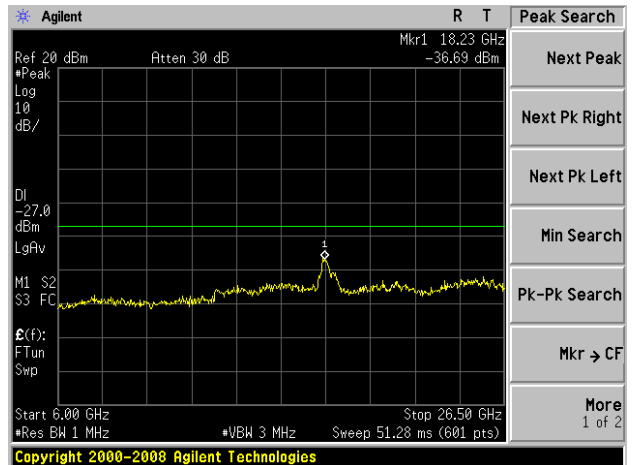

10. ANTENNA REQUIREMENT

10.1 STANDARD REQUIREMENT

15.203 requirement: For intentional device, according to 15.203: an intentional radiator shall be designed to ensure that no antenna other than that furnished by the responsible party shall be used with the device.

10.2 EUT ANTENNA

The EUT antenna is permanent attached FPCB antenna. It comply with the standard requirement.

END OF REPORT