



International Certification Corp.

No. 3-1, Lane 6, Wen San 3rd St., Kwei Shan Hsiang, Tao Yuan Hsien 333, Taiwan, R.O.C.

Tel: 886-3-271-8666

Fax: 886-3-318-0155

FCC Test Report

FCC ID : 2AAO2DOGSTICK
Equipment : dogStick
Model No. : DHQAR-W03
Brand Name : dog hunter
Applicant : dog hunter LLC
Address : 3F, 8 Faneuil Hall, Boston, MA 02109, USA
Standard : 47 CFR FCC Part 15.247
Received Date : Jun. 10, 2013
Tested Date : Jun. 10 ~ Jul. 04, 2013

We, International Certification Corp., would like to declare that the tested sample has been evaluated and in compliance with the requirement of the above standards. The test results contained in this report refer exclusively to the product. It may be duplicated completely for legal use with the approval of the applicant. It shall not be reproduced except in full without the written approval of our laboratory.

Approved & Reviewed by:

Gary Chang / Manager





Table of Contents

1	GENERAL DESCRIPTION	5
1.1	Information.....	5
1.2	Local Support Equipment List	7
1.3	Test Setup Chart	8
1.4	The Equipment List	9
1.5	Test Standards	10
1.6	Measurement Uncertainty	11
2	TEST CONFIGURATION	12
2.1	Testing Condition	12
2.2	The Worst Test Modes and Channel Details	12
3	TRANSMITTER TEST RESULTS.....	13
3.1	Conducted Emissions.....	13
3.2	6dB and Occupied Bandwidth	18
3.3	RF Output Power	21
3.4	Power Spectral Density	23
3.5	Unwanted Emissions into Restricted Frequency Bands	25
3.6	Unwanted Emissions into Non-Restricted Frequency Bands	55



International Certification Corp.

No. 3-1, Lane 6, Wen San 3rd St., Kwei Shan Hsiang, Tao Yuan Hsien 333, Taiwan, R.O.C.

Tel: 886-3-271-8666

Fax: 886-3-318-0155

Release Record

Report No.	Version	Description	Issued Date
FR362603	Rev. 01	Initial issue	Jul. 29, 2013



Summary of Test Results

FCC Rules	Test Items	Measured	Result
15.207	Conducted Emissions	[dBuV]: 14.152MHz 45.08 (Margin -4.92dB) - AV	Pass
15.247(d) 15.209	Radiated Emissions	[dBuV/m at 3m]: 2483.50MHz 72.98 (Margin -1.02dB) - PK	Pass
15.247(b)(3)	Fundamental Emission Output Power	Power [dBm]: 11b: 17.15 11g: 21.53 HT20: 21.52 HT40: 18.62	Pass
15.247(a)(2)	6dB Bandwidth	Meet the requirement of limit	Pass
15.247(e)	Power Spectral Density	Meet the requirement of limit	Pass
15.203	Antenna Requirement	Meet the requirement of limit	Pass



1 General Description

1.1 Information

1.1.1 Specification of the Equipment under Test (EUT)

RF General Information					
Frequency Range (MHz)	IEEE Std. 802.11	Ch. Freq. (MHz)	Channel Number	Transmit Chains (N _{TX})	Data Rate / MCS
2400-2483.5	b	2412-2462	1-11 [11]	1	1-11 Mbps
2400-2483.5	g	2412-2462	1-11 [11]	1	6-54 Mbps
2400-2483.5	n (HT20)	2412-2462	1-11 [11]	1	MCS 0-7
2400-2483.5	n (HT40)	2422-2452	3-9 [7]	1	MCS 0-7

Note 1: RF output power specifies that Maximum Peak Conducted Output Power.
 Note 2: 802.11b uses a combination of DSSS-DBPSK, DQPSK, CCK modulation.
 Note 3: 802.11g/n uses a combination of OFDM-BPSK, QPSK, 16QAM, 64QAM modulation.

1.1.2 Antenna Details

Ant. No.	Type	Gain (dBi)	Connector	Remark
1	Chip antenna	1.67	---	---

1.1.3 EUT Operational Condition

Supply Voltage	<input type="checkbox"/> AC mains	<input checked="" type="checkbox"/> DC	
Type of DC Source	<input type="checkbox"/> Internal DC supply	<input type="checkbox"/> External DC adapter	<input checked="" type="checkbox"/> 5Vdc from host (USB mode) 48Vdc from POE (POE mode)

1.1.4 Accessories

N/A



1.1.5 Channel List

Frequency band (MHz)		2400~2483.5	
802.11 b / g / n HT20		802.11n HT40	
Channel	Frequency(MHz)	Channel	Frequency(MHz)
1	2412	3	2422
2	2417	4	2427
3	2422	5	2432
4	2427	6	2437
5	2432	7	2442
6	2437	8	2447
7	2442	9	2452
8	2447	---	---
9	2452	---	---
10	2457	---	---
11	2462	---	---

1.1.6 Test Tool and Duty Cycle

Test tool	ART2-GUI, V2.3
Duty Cycle Of Test Signal (%)	100.00% - IEEE 802.11b 98.27% - IEEE 802.11g 98.13% - IEEE 802.11n (HT20) 97.75% - IEEE 802.11n (HT40)
Duty Factor	0.00 - IEEE 802.11b 0.08 - IEEE 802.11g 0.08 - IEEE 802.11n (HT20) 0.10 - IEEE 802.11n (HT40)



1.1.7 Power Setting

Modulation Mode	Test Frequency (MHz)	Power Set
11b	2412	22.5
11b	2437	19.5
11b	2462	18.5
11g	2412	21.5
11g	2437	25.0
11g	2462	14.5
HT20	2412	21.0
HT20	2437	25.0
HT20	2462	14.0
HT40	2422	18.5
HT40	2437	18.5
HT40	2452	13.5

1.2 Local Support Equipment List

Support Equipment List						
No.	Equipment	Brand	Model	S/N	FCC ID	Signal cable / Length (m)
1	Notebook	DELL	E6430	---	DoC	RJ45, 1.5m non-shielded cable w/o core. USB, 1m non-shielded cable w/o core.
2	Flash	Transcend	JetFlash V85	---	DoC	---
3	POE	---	PD-3001/AC	---	---	RJ45, 10m non-shielded cable w/o core.



1.3 Test Setup Chart

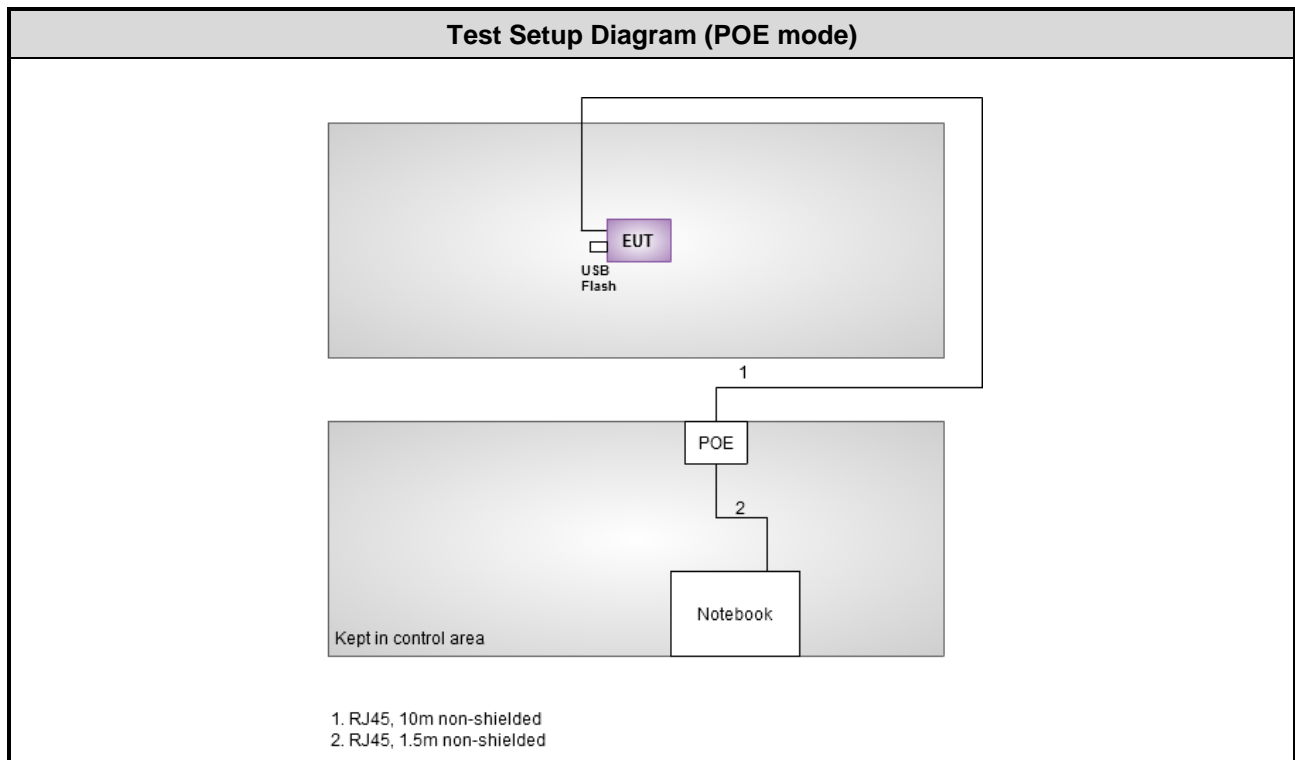
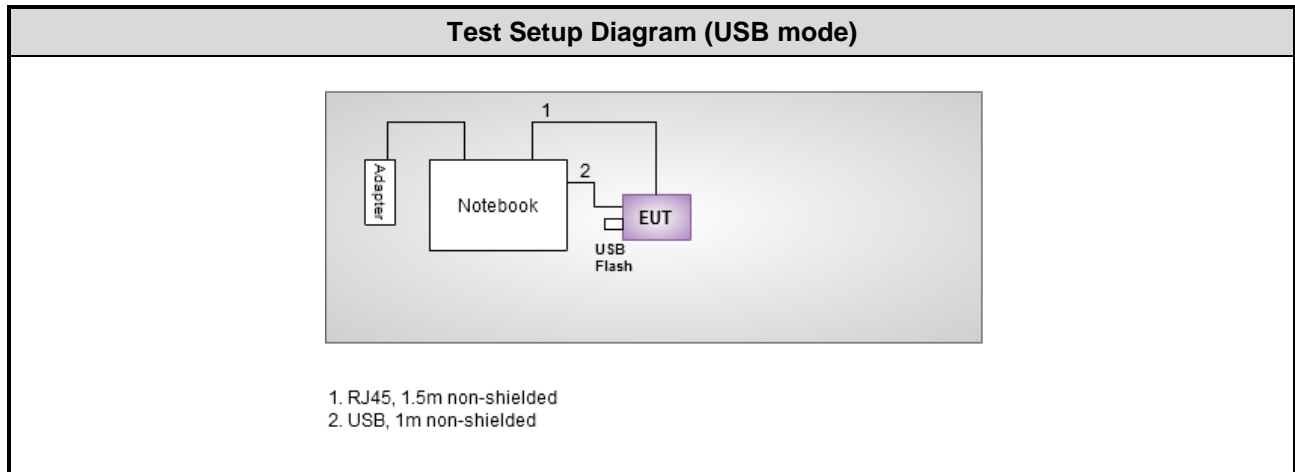



1.4 The Equipment List

Test Item	Conducted Emission				
Test Site	Conduction room 1 / (CO01-WS)				
Instrument	Manufacturer	Model No.	Serial No.	Calibration Date	Calibration Until
EMC Receiver	R&S	ESCS 30	100169	Oct. 02, 2012	Oct. 01, 2013
LISN	SCHWARZBECK MESS-ELEKTRONIK	Schwarzbeck 8127	8127-667	Dec. 04, 2012	Dec. 03, 2013
LISN (Support Unit)	SCHWARZBECK MESS-ELEKTRONIK	Schwarzbeck 8127	8127-666	Dec. 04, 2012	Dec. 03, 2013
ISN	TESEQ	ISN T800	34406	Apr. 08, 2013	Apr. 07, 2014
ISN	TESEQ	ISN T200A	30494	Apr. 09, 2013	Apr. 08, 2014
ISN	TESEQ	ISN T8-Cat6	27262	Sep. 17, 2012	Sep. 16, 2013
ISN	TESEQ	ISN ST08	22589	Jan. 24, 2013	Jan. 23, 2014
RF Current Probe	FCC	F-33-4	121630	Dec. 04, 2012	Dec. 03, 2013
RF Cable-CON	Woken	CFD200-NL	CFD200-NL-001	Dec. 25, 2012	Dec. 24, 2013
ESH3-Z6 V-Network(+)	R&S	ESH3-Z6	100920	Nov. 21, 2012	Nov. 20, 2013
ESH3-Z6 V-Network(-)	R&S	ESH3-Z6	100951	Jan. 30, 2013	Jan. 29, 2014
Two-Line V-Network	R&S	ENV216	101579	Jan. 07, 2013	Jan. 06, 2014
50 ohm terminal	NA	50	01	Apr. 22, 2013	Apr. 21, 2014
50 ohm terminal	NA	50	02	Apr. 22, 2013	Apr. 21, 2014
50 ohm terminal	NA	50	03	Apr. 22, 2013	Apr. 21, 2014
50 ohm terminal (Support Unit)	NA	50	04	Apr. 22, 2013	Apr. 21, 2014

Note: Calibration Interval of instruments listed above is one year.



Test Item	Radiated Emission above 1GHz				
Test Site	966 chamber1 / (03CH01-WS)				
Instrument	Manufacturer	Model No.	Serial No.	Calibration Date	Calibration Until
3m semi-anechoic chamber	CHAMPRO	SAC-03	03CH01-WS	Jan. 04, 2013	Jan. 03, 2014
Spectrum Analyzer	R&S	FSV40	101498	Jan. 24, 2013	Jan. 23, 2014
Receiver	ROHDE&SCHWARZ	ESR3	101658	Jan. 28, 2013	Jan. 27, 2014
Bilog Antenna	SCHWARZBECK	VULB9168	VULB9168-522	Jan. 11, 2013	Jan. 10, 2014
Horn Antenna 1G-18G	SCHWARZBECK	BBHA 9120 D	BBHA 9120 D 1096	Feb. 18, 2013	Feb. 17, 2014
Horn Antenna 18G-40G	SCHWARZBECK	BBHA 9170	BBHA 9170517	Jan. 14, 2013	Jan. 13, 2014
Amplifier	Burgeon	BPA-530	100219	Nov. 28, 2012	Nov. 27, 2013
Amplifier	Agilent	83017A	MY39501308	Dec. 18, 2012	Dec. 17, 2013
RF Cable	HUBER+SUHNER	SUCOFLEX104	MY16014/4	Dec. 25, 2012	Dec. 24, 2013
RF Cable	HUBER+SUHNER	SUCOFLEX104	MY16019/4	Dec. 25, 2012	Dec. 24, 2013
RF Cable	HUBER+SUHNER	SUCOFLEX104	MY16139/4	Dec. 25, 2012	Dec. 24, 2013
RF Cable-R03m	Woken	CFD400NL-LW	CFD400NL-001	Dec. 25, 2012	Dec. 24, 2013
RF Cable-R10m	Woken	CFD400NL-LW	CFD400NL-002	Dec. 25, 2012	Dec. 24, 2013
control	EM Electronics	EM1000	60612	N/A	N/A
Note: Calibration Interval of instruments listed above is one year.					

Loop Antenna	R&S	HFH2-Z2	100330	Nov. 15, 2012	Nov. 14, 2014
Amplifier	MITEQ	AMF-6F-260400	9121372	Apr. 19, 2013	Apr. 18, 2015
Note: Calibration Interval of instruments listed above is two year.					

1.5 Test Standards

According to the specification of EUT, the EUT must comply with following standards and KDB documents.

47 CFR FCC Part 15.247

ANSI C63.10-2009

FCC KDB 558074 D01 DTS Meas Guidance v03

Note: The EUT has been tested and complied with FCC part 15B requirement. FCC Part 15B test results are issued to another report.



1.6 Measurement Uncertainty

ISO/IEC 17025 requires that an estimate of the measurement uncertainties associated with the emissions test results be included in the report. The measurement uncertainties given below are based on a 95% confidence level (based on a coverage factor (k=2))

Measurement Uncertainty	
Parameters	Uncertainty
Bandwidth	±35.286 Hz
Conducted power	±0.536 dB
Frequency error	±35.286 Hz
Temperature	±0.3 °C
Conducted emission	±2.946 dB
AC conducted emission	±2.43 dB
Radiated emission	±2.49 dB



2 Test Configuration

2.1 Testing Condition

Test Item	Test Site	Ambient Condition	Tested By
AC Conduction	CO01-WS	23°C / 68%	Peter Lin
Radiated Emissions	03CH01-WS	25°C / 65%	Aska Huang Haru Yang
RF Conducted	TH01-WS	25°C / 60%	Felix Sung

➤ FCC site registration No.: 657002

➤ IC site registration No.: 10807A-1

2.2 The Worst Test Modes and Channel Details

Test item	Modulation Mode	Test Frequency (MHz)	Data rate (Mbps)	Test Configuration
Conducted Emissions	11g	2437	6	1, 2
Radiated Emissions (below 1GHz)	11g	2437	6	1, 2
Radiated Emissions (above 1GHz)	11b	2412 / 2437 / 2462	1	2
	11g	2412 / 2437 / 2462	6	
	HT20	2412 / 2437 / 2462	MCS 0	
	HT40	2422 / 2437 / 2452	MCS 0	
Fundamental Emission Output Power 6dB bandwidth Power spectral density	11b	2412 / 2437 / 2462	1	2
	11g	2412 / 2437 / 2462	6	
	HT20	2412 / 2437 / 2462	MCS 0	
	HT40	2422 / 2437 / 2452	MCS 0	

NOTE:

- The EUT was pretested with 3 orientations placed on the table for the radiated emission measurement – X, Y, and Z-plane. The **Z-plane** results were found as the worst case and were shown in this report.
- The EUT supports two kinds of power supply modes, USB and POE mode. Both options were tested and was recorded in this report.
 - Configuration 1 : USB mode
 - Configuration 2 : POE mode



3 Transmitter Test Results

3.1 Conducted Emissions

3.1.1 Limit of Conducted Emissions

Conducted Emissions Limit		
Frequency Emission (MHz)	Quasi-Peak	Average
0.15-0.5	66 - 56 *	56 - 46 *
0.5-5	56	46
5-30	60	50

Note 1: * Decreases with the logarithm of the frequency.

3.1.2 Test Procedures

1. The device is placed on a test table, raised 80 cm above the reference ground plane. The vertical conducting plane is located 40 cm to the rear of the device.
2. The device is connected to line impedance stabilization network (LISN) and other accessories are connected to other LISN. Measured levels of AC power line conducted emission are across the 50 Ω LISN port.
3. AC conducted emission measurements is made over frequency range from 150 kHz to 30 MHz.
4. This measurement was performed with AC 120V / 60Hz.

3.1.3 Test Setup

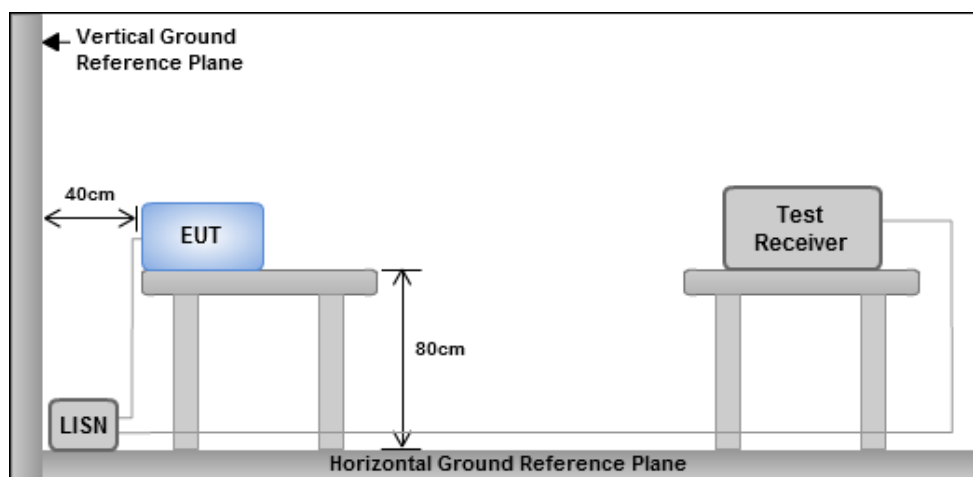

Note: 1. Support units were connected to second LISN.

2. Both of LISNs (AMN) are 80 cm from EUT and at least 80 cm from other units and other metal planes



3.1.4 Test Result of Conducted Emissions

Modulation	11g	Test Freq. (MHz)	2437
Power Phase	Line	Test Configuration	1

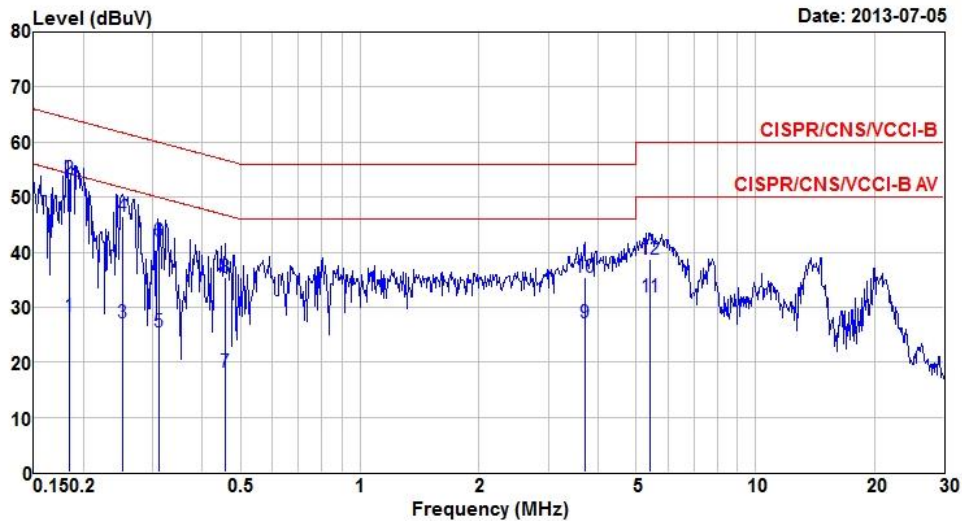

	Freq MHz	Level dBuV	Limit Line dBuV	Over Limit dB	Read Level dBuV	LISN factor dB	cable loss dB	Remark
1	0.185	28.41	54.27	-25.86	28.23	0.03	0.15	Average
2	0.185	53.36	64.27	-10.91	53.18	0.03	0.15	QP
3	0.251	27.10	51.73	-24.63	26.93	0.03	0.14	Average
4	0.251	46.46	61.73	-15.27	46.29	0.03	0.14	QP
5	0.310	25.40	49.98	-24.58	25.27	0.03	0.10	Average
6	0.310	42.02	59.98	-17.96	41.89	0.03	0.10	QP
7	0.456	18.24	46.76	-28.52	18.16	0.03	0.05	Average
8	0.456	35.41	56.76	-21.35	35.33	0.03	0.05	QP
9	3.700	27.21	46.00	-18.79	26.92	0.06	0.23	Average
10	3.700	35.32	56.00	-20.68	35.03	0.06	0.23	QP
11	5.419	31.87	50.00	-18.13	31.60	0.07	0.20	Average
12	5.419	38.72	60.00	-21.28	38.45	0.07	0.20	QP

Note 1: Level (dBuV) = Read Level (dBuV) + LISN Factor (dB) + Cable Loss (dB).

2: Over Limit (dBuV) = Limit Line (dBuV) – Level (dBuV).



Modulation	11g	Test Freq. (MHz)	2437
Power Phase	Neutral	Test Configuration	1

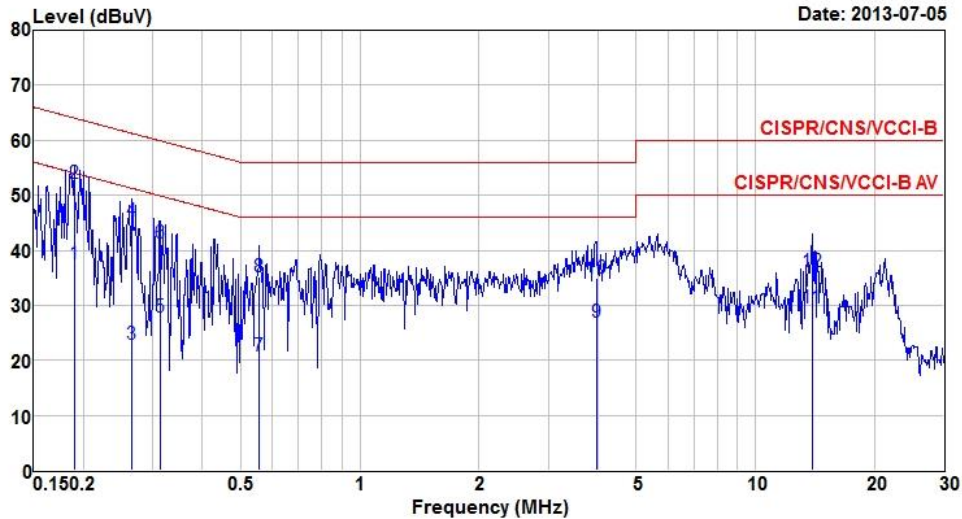

	Freq	Level	Limit	Over	Read	LISN	cable	Remark
	MHz	dBuV	Line	Limit	Level	factor	loss	
			dBuV	dB	dBuV	dB	dB	
1	0.189	37.65	54.06	-16.41	37.47	0.02	0.16	Average
2	0.189	52.21	64.06	-11.85	52.03	0.02	0.16	QP
3	0.264	22.92	51.29	-28.37	22.77	0.02	0.13	Average
4	0.264	45.26	61.29	-16.03	45.11	0.02	0.13	QP
5	0.312	27.82	49.92	-22.10	27.70	0.02	0.10	Average
6	0.312	41.38	59.92	-18.54	41.26	0.02	0.10	QP
7	0.558	20.71	46.00	-25.29	20.64	0.02	0.05	Average
8	0.558	35.21	56.00	-20.79	35.14	0.02	0.05	QP
9	3.964	27.01	46.00	-18.99	26.72	0.05	0.24	Average
10	3.964	34.91	56.00	-21.09	34.62	0.05	0.24	QP
11	13.915	29.42	50.00	-20.58	29.18	0.11	0.13	Average
12	13.915	36.04	60.00	-23.96	35.80	0.11	0.13	QP

Note 1: Level (dBuV) = Read Level (dBuV) + LISN Factor (dB) + Cable Loss (dB).
 Note 2: Over Limit (dBuV) = Limit Line (dBuV) – Level (dBuV).



Modulation	11g	Test Freq. (MHz)	2437
Power Phase	Line	Test Configuration	2

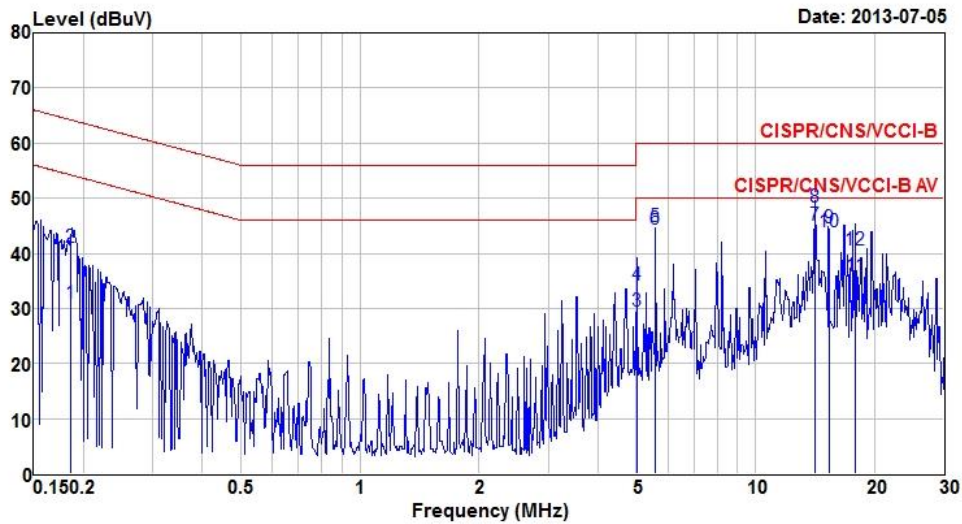

	Freq	Level	Limit	Over	Read	LISN	cable	Remark
	MHz	dBuV	Line	Limit	Level	factor	loss	
			dBuV	dB	dBuV	dB	dB	
1	0.186	30.92	54.21	-23.29	30.74	0.03	0.15	Average
2	0.186	41.04	64.21	-23.17	40.86	0.03	0.15	QP
3	5.011	29.55	50.00	-20.45	29.27	0.07	0.21	Average
4	5.011	34.17	60.00	-25.83	33.89	0.07	0.21	QP
5	5.602	44.82	50.00	-5.18	44.56	0.07	0.19	Average
6	5.602	44.34	60.00	-15.66	44.08	0.07	0.19	QP
7	14.152	45.08	50.00	-4.92	44.83	0.12	0.13	Average
8	14.152	48.33	60.00	-11.67	48.08	0.12	0.13	QP
9	15.330	44.63	50.00	-5.37	44.38	0.12	0.13	Average
10	15.330	43.98	60.00	-16.02	43.73	0.12	0.13	QP
11	17.938	35.76	50.00	-14.24	35.47	0.12	0.17	Average
12	17.938	40.68	60.00	-19.32	40.39	0.12	0.17	QP

Note 1: Level (dBuV) = Read Level (dBuV) + LISN Factor (dB) + Cable Loss (dB).
 Note 2: Over Limit (dBuV) = Limit Line (dBuV) – Level (dBuV).



Modulation	11g	Test Freq. (MHz)	2437
Power Phase	Neutral	Test Configuration	2

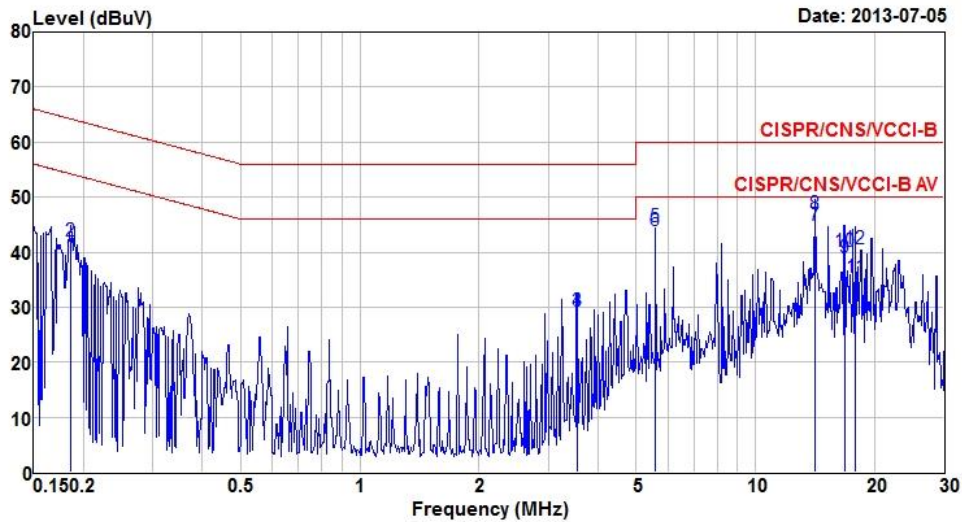

	Freq	Level	Limit	Over	Read	LISN	cable	
	MHz	dBuV	Line	Limit	Level	factor	loss	Remark
			dBuV	dB	dBuV	dB	dB	
1	0.186	39.10	54.20	-15.10	38.93	0.02	0.15	Average
2	0.186	42.01	64.20	-22.19	41.84	0.02	0.15	QP
3	3.537	29.26	46.00	-16.74	28.98	0.05	0.23	Average
4	3.537	29.21	56.00	-26.79	28.93	0.05	0.23	QP
5	5.602	44.62	50.00	-5.38	44.37	0.06	0.19	Average
6	5.602	44.01	60.00	-15.99	43.76	0.06	0.19	QP
7	14.152	44.89	50.00	-5.11	44.65	0.11	0.13	Average
8	14.152	47.03	60.00	-12.97	46.79	0.11	0.13	QP
9	16.839	38.98	50.00	-11.02	38.72	0.11	0.15	Average
10	16.839	40.07	60.00	-19.93	39.81	0.11	0.15	QP
11	17.939	35.45	50.00	-14.55	35.17	0.11	0.17	Average
12	17.939	40.50	60.00	-19.50	40.22	0.11	0.17	QP

Note 1: Level (dBuV) = Read Level (dBuV) + LISN Factor (dB) + Cable Loss (dB).
 Note 2: Over Limit (dBuV) = Limit Line (dBuV) – Level (dBuV).



3.2 6dB and Occupied Bandwidth

3.2.1 Limit of 6dB Bandwidth

The minimum 6dB bandwidth shall be at least 500 kHz.

3.2.2 Test Procedures

1. Set resolution bandwidth (RBW) = 100 kHz, Video bandwidth = 300 kHz.
2. Detector = Peak, Trace mode = max hold.
3. Sweep = auto couple, Allow the trace to stabilize.
4. Measure the maximum width of the emission that is constrained by the frequencies associated with the two outermost amplitude points (upper and lower) that are attenuated by 6dB relative to the maximum level measured in the fundamental emission.

3.2.3 Test Setup

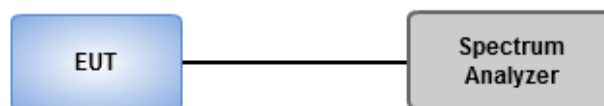



3.2.4 Test Result of 6dB and Occupied Bandwidth

Modulation Mode	N _{TX}	Freq. (MHz)	6dB Bandwidth (MHz)				Limit (kHz)
			Chain 0	Chain 1	Chain 2	Chain 3	
11b	1	2412	10.09	---	---	---	500
11b	1	2437	10.03	---	---	---	500
11b	1	2462	10.09	---	---	---	500
11g	1	2412	16.35	---	---	---	500
11g	1	2437	16.35	---	---	---	500
11g	1	2462	16.35	---	---	---	500
HT20	1	2412	17.57	---	---	---	500
HT20	1	2437	17.28	---	---	---	500
HT20	1	2462	17.28	---	---	---	500
HT40	1	2422	36.29	---	---	---	500
HT40	1	2437	36.41	---	---	---	500
HT40	1	2452	36.06	---	---	---	500

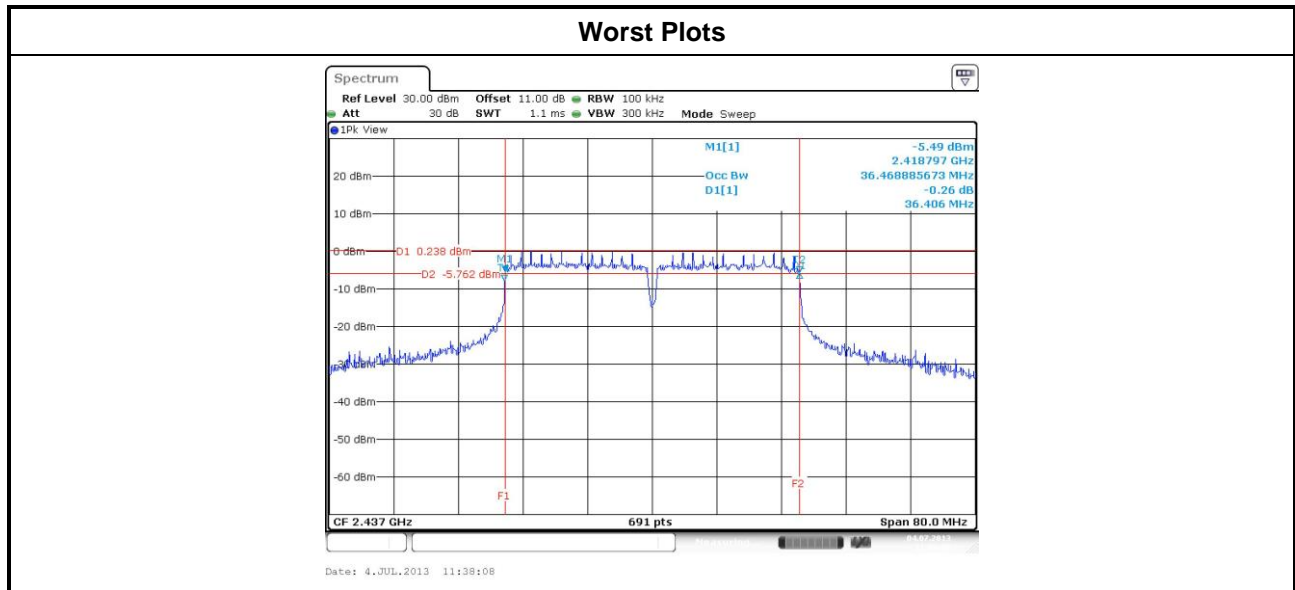



Modulation Mode	N _{TX}	Freq. (MHz)	99% Occupied Bandwidth (MHz)			
			Chain 0	Chain 1	Chain 2	Chain 3
11b	1	2412	14.30	---	---	---
11b	1	2437	14.30	---	---	---
11b	1	2462	14.24	---	---	---
11g	1	2412	18.18	---	---	---
11g	1	2437	27.50	---	---	---
11g	1	2462	17.60	---	---	---
HT20	1	2412	19.16	---	---	---
HT20	1	2437	26.92	---	---	---
HT20	1	2462	18.58	---	---	---
HT40	1	2422	38.44	---	---	---
HT40	1	2437	39.02	---	---	---
HT40	1	2452	38.44	---	---	---

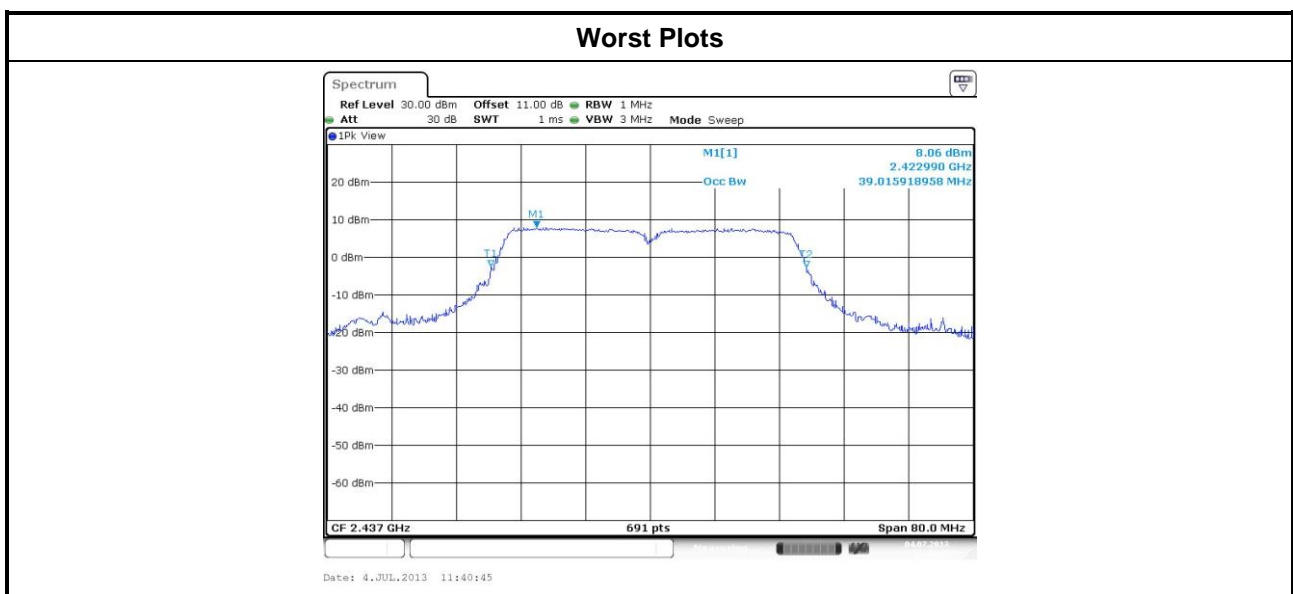



3.3 RF Output Power

3.3.1 Limit of RF Output Power

Conducted power shall not exceed 1Watt.

- Antenna gain \leq 6dBi, no any corresponding reduction is in output power limit.
- Antenna gain $>$ 6dBi
 - Non Fixed, point to point operations.
The conducted output power from the intentional radiator shall be reduced by the amount in dB that the directional gain of the antenna exceeds 6 dB
 - Fixed, point to point operations
Systems operating in the 2400–2483.5 MHz band that are used exclusively for fixed, point-to-point Operations, maximum peak output power of the intentional radiator is reduced by 1 dB for every 3 dB that the directional gain of the antenna exceeds 6 dBi.

Systems operating in the 5725–5850 MHz band that are used exclusively for fixed, point-to-point operations ,no any corresponding reduction is in transmitter peak output power

3.3.2 Test Procedures

- Maximum Peak Conducted Output Power
 - Spectrum analyzer**
 1. Set RBW = 1MHz, VBW = 3MHz, Detector = Peak.
 2. Sweep time = auto, Trace mode = max hold, Allow trace to fully stabilize.
 3. Use the spectrum analyzer channel power measurement function with the band limits set equal to the DTS bandwidth edges.
 - Power meter**
 1. A broadband Peak RF power meter is used for output power measurement. The video bandwidth of power meter is greater than DTS bandwidth of EUT. If duty cycle of test signal is not 100 %, trigger and gating function of power meter will be enabled to capture transmission burst for measuring output power.
- Maximum Conducted Output Power (For reference only)
 - Power meter**
 1. A broadband Average RF power meter is used for output power measurement. The video bandwidth of power meter is greater than DTS bandwidth of EUT. If duty cycle of test signal is not 100 %, trigger and gating function of power meter will be enabled to capture transmission burst for measuring output power.

3.3.3 Test Setup

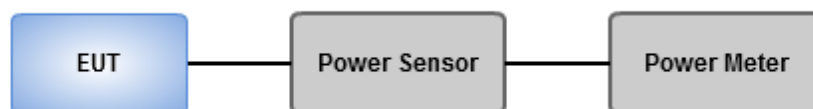



3.3.4 Test Result of Maximum Output Power

Modulation Mode	N _{TX}	Freq. (MHz)	Peak conducted output power (dBm)				Total Power (mW)	Total Power (dBm)	Limit (dBm)
			Chain 0	Chain 1	Chain 2	Chain 3			
11b	1	2412	16.96	---	---	---	49.66	16.96	30
11b	1	2437	16.81	---	---	---	47.97	16.81	30
11b	1	2462	17.15	---	---	---	51.88	17.15	30
11g	1	2412	19.55	---	---	---	90.16	19.55	30
11g	1	2437	21.53	---	---	---	142.23	21.53	30
11g	1	2462	18.84	---	---	---	76.56	18.84	30
HT20	1	2412	19.41	---	---	---	87.30	19.41	30
HT20	1	2437	21.52	---	---	---	141.91	21.52	30
HT20	1	2462	18.64	---	---	---	73.11	18.64	30
HT40	1	2422	17.92	---	---	---	61.94	17.92	30
HT40	1	2437	18.62	---	---	---	72.78	18.62	30
HT40	1	2452	16.73	---	---	---	47.10	16.73	30

Modulation Mode	N _{TX}	Freq. (MHz)	Conducted (average) output power (dBm)				Total Power (mW)	Total Power (dBm)	Limit (dBm)
			Chain 0	Chain 1	Chain 2	Chain 3			
11b	1	2412	15.27	---	---	---	33.65	15.27	30
11b	1	2437	15.06	---	---	---	32.06	15.06	30
11b	1	2462	15.43	---	---	---	34.91	15.43	30
11g	1	2412	14.81	---	---	---	30.27	14.81	30
11g	1	2437	18.45	---	---	---	69.98	18.45	30
11g	1	2462	13.11	---	---	---	20.46	13.11	30
HT20	1	2412	14.52	---	---	---	28.31	14.52	30
HT20	1	2437	18.44	---	---	---	69.82	18.44	30
HT20	1	2462	12.77	---	---	---	18.92	12.77	30
HT40	1	2422	12.28	---	---	---	16.90	12.28	30
HT40	1	2437	13.65	---	---	---	23.17	13.65	30
HT40	1	2452	10.69	---	---	---	11.72	10.69	30

Note: Conducted average output power is for reference only.



3.4 Power Spectral Density

3.4.1 Limit of Power Spectral Density

Power spectral density shall not be greater than 8 dBm in any 3 kHz band.

3.4.2 Test Procedures

- Maximum peak conducted output power was used to demonstrate compliance to the fundamental output power limit.
 1. Set the RBW = 30kHz, VBW = 100kHz.
 2. Detector = Peak, Sweep time = auto couple.
 3. Trace mode = max hold, allow trace to fully stabilize.
 4. Use the peak marker function to determine the maximum amplitude level.
- Maximum (average) conducted output power was used to demonstrate compliance to the fundamental output power limit.
 1. Set the RBW = 100kHz, VBW = 300 kHz.
 2. Detector = RMS, Sweep time = auto couple.
 3. Set the sweep time to: $\geq 10 \times (\text{number of measurement points in sweep}) \times (\text{maximum data rate per stream})$.
 4. Perform the measurement over a single sweep.
 5. Use the peak marker function to determine the maximum amplitude level.\

3.4.3 Test Setup

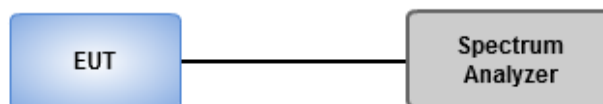



3.4.4 Test Result of Power Spectral Density

Modulation Mode	N _{TX}	Freq. (MHz)	Total Power Spectral Density (dBm/30kHz)	Limit (dBm/3kHz)
11b	1	2412	1.48	8
11b	1	2437	1.69	8
11b	1	2462	1.81	8
11g	1	2412	-0.83	8
11g	1	2437	2.87	8
11g	1	2462	-1.95	8
HT20	1	2412	-1.11	8
HT20	1	2437	3.13	8
HT20	1	2462	-1.83	8
HT40	1	2422	-6.79	8
HT40	1	2437	-5.40	8
HT40	1	2452	-7.85	8

Worst Plots

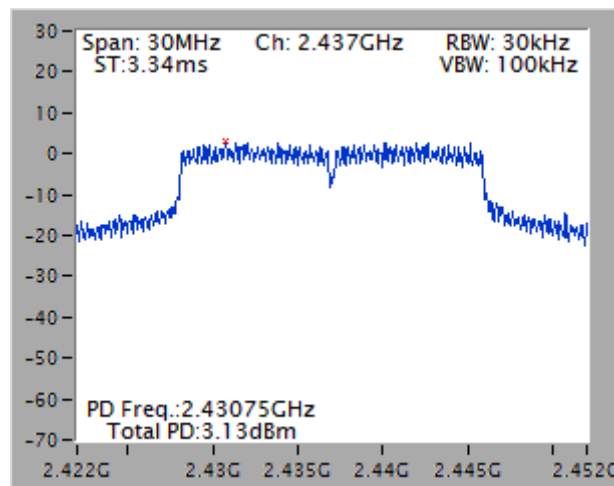



3.5 Unwanted Emissions into Restricted Frequency Bands

3.5.1 Limit of Unwanted Emissions into Restricted Frequency Bands

Restricted Band Emissions Limit			
Frequency Range (MHz)	Field Strength (uV/m)	Field Strength (dBuV/m)	Measure Distance (m)
0.009~0.490	2400/F(kHz)	48.5 - 13.8	300
0.490~1.705	24000/F(kHz)	33.8 - 23	30
1.705~30.0	30	29	30
30~88	100	40	3
88~216	150	43.5	3
216~960	200	46	3
Above 960	500	54	3

Note 1:
 Qusai-Peak value is measured for frequency below 1GHz except for 9–90 kHz, 110–490 kHz frequency band. Peak and average value are measured for frequency above 1GHz. The limit on average radio frequency emission is as above table. The limit on peak radio frequency emissions is 20 dB above the maximum permitted average emission limit

Note 2:
 Measurements may be performed at a distance other than what is specified provided. When performing measurements at a distance other than that specified, the results shall be extrapolated to the specified distance using an extrapolation factor as below, Frequency at or above 30 MHz: 20 dB/decade Frequency below 30 MHz: 40 dB/decade.

3.5.2 Test Procedures

1. Measurement is made at a semi-anechoic chamber that incorporates a turntable allowing a EUT rotation of 360°. A continuously-rotating, remotely-controlled turntable is installed at the test site to support the EUT and facilitate determination of the direction of maximum radiation for each EUT emission frequency. The EUT is placed at a height of 0.8 m test table above the ground plane.
2. Measurement is made with the antenna positioned in both the horizontal and vertical planes of polarization. The measurement antenna is varied in height (1m ~ 4m) above the reference ground plane to obtain the maximum signal strength. Distance between EUT and antenna is 3 m.
3. This investigation is performed with the EUT rotated 360°, the antenna height scanned between 1 m and 4 m, and the antenna rotated to repeat the measurements for both the horizontal and vertical antenna polarizations.

Note:

1. 120kHz measurement bandwidth of test receiver and Quasi-peak detector is for radiated emission below 1GHz.
2. RBW=1MHz, VBW=3MHz and Peak detector is for peak measured value of radiated emission above 1GHz.
3. RBW=1MHz, VBW=1/T and Peak detector is for average measured value of radiated emission above 1GHz.



3.5.3 Test Setup

Radiated Emissions below 1 GHz

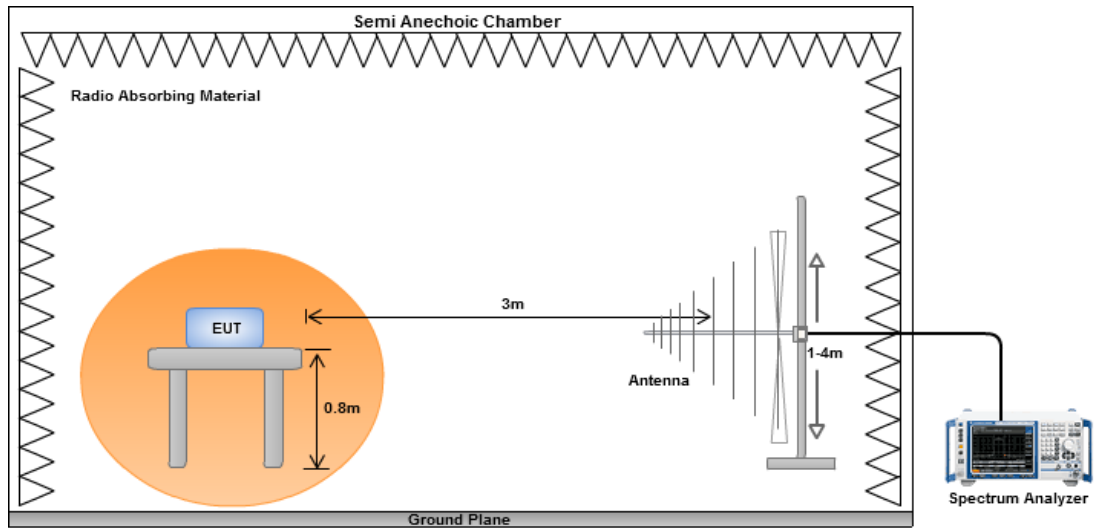

Radiated Emissions above 1 GHz

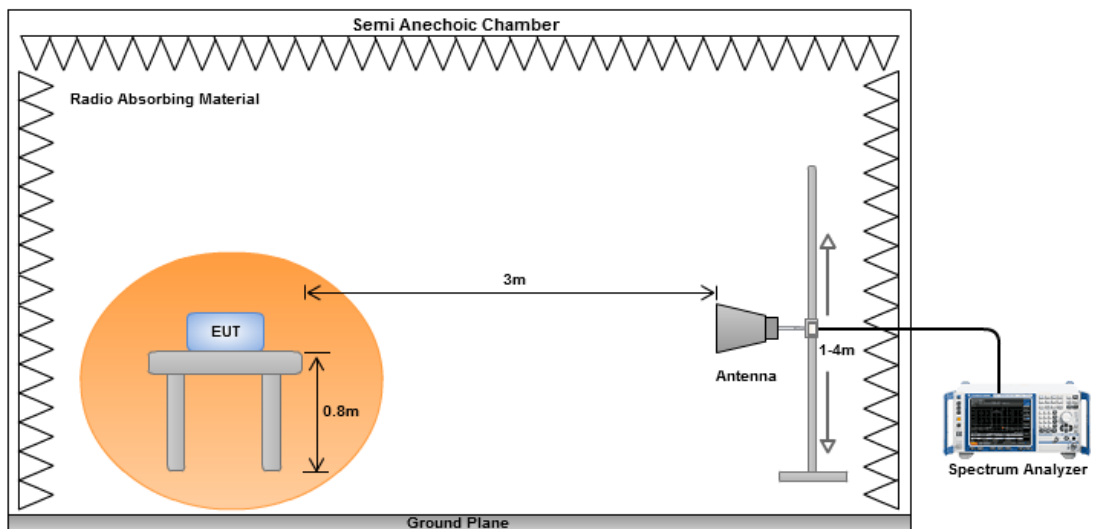



3.5.4 Transmitter Radiated Unwanted Emissions (Below 1GHz)

Modulation	11g	Test Freq. (MHz)	2437
Polarization	Horizontal	Test Configuration	1

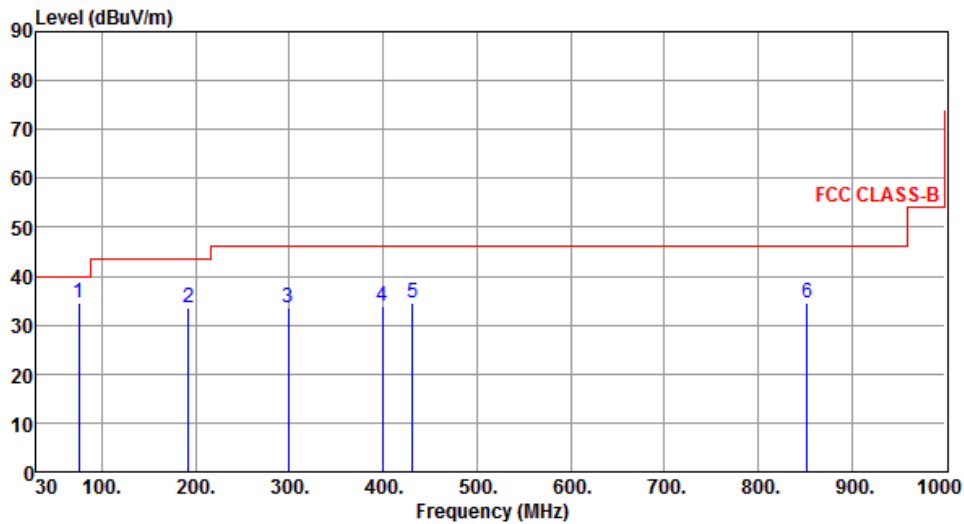

	Freq. MHz	Emission level dBuV/m	Limit dBuV/m	Margin dB	SA reading dBuV	Factor dB	Remark	ANT High cm	Turn Table deg
1	75.59	34.60	40.00	-5.40	55.27	-20.67	Peak	---	---
2	191.99	33.63	43.50	-9.87	52.76	-19.13	Peak	---	---
3	298.69	33.63	46.00	-12.37	49.89	-16.26	Peak	---	---
4	399.57	33.86	46.00	-12.14	47.53	-13.67	Peak	---	---
5	431.58	34.55	46.00	-11.45	47.44	-12.89	Peak	---	---
6	852.56	34.46	46.00	-11.54	40.55	-6.09	Peak	---	---

Note 1: Emission Level (dBuV/m) = SA Reading (dBuV/m) + Factor* (dB)

*Factor includes antenna factor , cable loss and amplifier gain

Note 2: Margin (dB) = Emission level (dBuV/m) – Limit (dBuV/m).



Modulation	11g	Test Freq. (MHz)	2437
Polarization	Vertical	Test Configuration	1

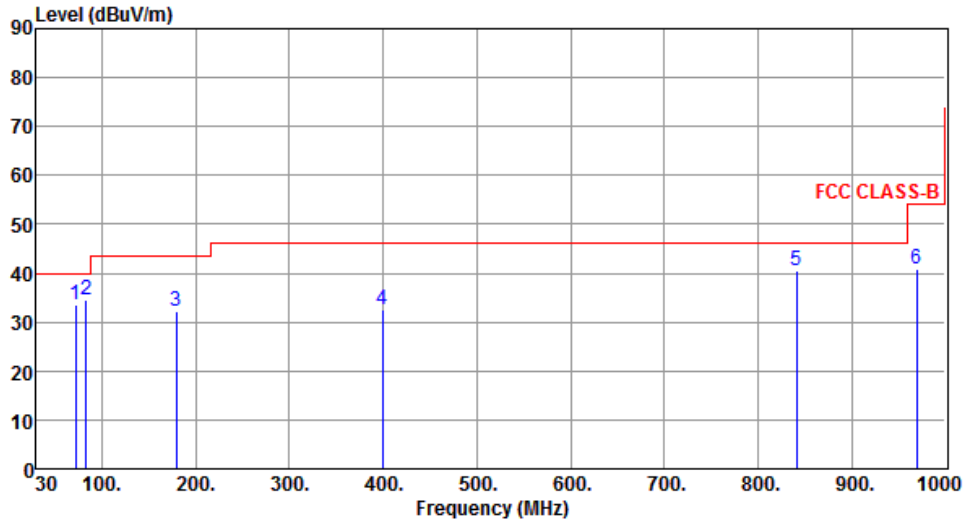

	Freq. MHz	Emission level dBuV/m	Limit dBuV/m	Margin dB	SA reading dBuV	Factor dB	Remark	ANT High cm	Turn Table deg
1	71.71	33.51	40.00	-6.49	53.17	-19.66	Peak	---	---
2	83.35	34.45	40.00	-5.55	56.62	-22.17	Peak	---	---
3	179.38	32.35	43.50	-11.15	50.63	-18.28	Peak	---	---
4	399.57	32.46	46.00	-13.54	46.13	-13.67	Peak	---	---
5	840.92	40.62	46.00	-5.38	46.87	-6.25	Peak	---	---
6	968.96	40.75	54.00	-13.25	45.45	-4.70	Peak	---	---

Note 1: Emission Level (dBuV/m) = SA Reading (dBuV/m) + Factor* (dB)

*Factor includes antenna factor , cable loss and amplifier gain

Note 2: Margin (dB) = Emission level (dBuV/m) – Limit (dBuV/m).



Modulation	11g	Test Freq. (MHz)	2437
Polarization	Horizontal	Test Configuration	2

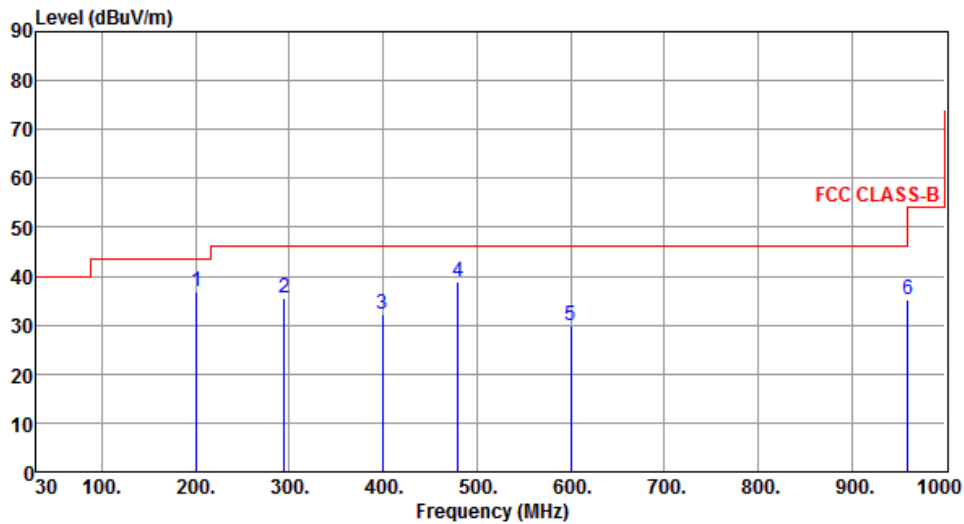

	Freq. MHz	Emission level dBuV/m	Limit dBuV/m	Margin dB	SA reading dBuV	Factor dB	Remark	ANT High cm	Turn Table deg
1	200.72	36.79	43.50	-6.71	56.05	-19.26	Peak	---	---
2	294.81	35.70	46.00	-10.30	52.00	-16.30	Peak	---	---
3	399.57	32.34	46.00	-13.66	46.01	-13.67	Peak	---	---
4	480.08	38.72	46.00	-7.28	50.70	-11.98	Peak	---	---
5	600.36	29.91	46.00	-16.09	39.65	-9.74	Peak	---	---
6	960.23	35.12	54.00	-18.88	39.88	-4.76	Peak	---	---

Note 1: Emission Level (dBuV/m) = SA Reading (dBuV/m) + Factor* (dB)

*Factor includes antenna factor , cable loss and amplifier gain

Note 2: Margin (dB) = Emission level (dBuV/m) – Limit (dBuV/m).



Modulation	11g	Test Freq. (MHz)	2437
Polarization	Vertical	Test Configuration	2

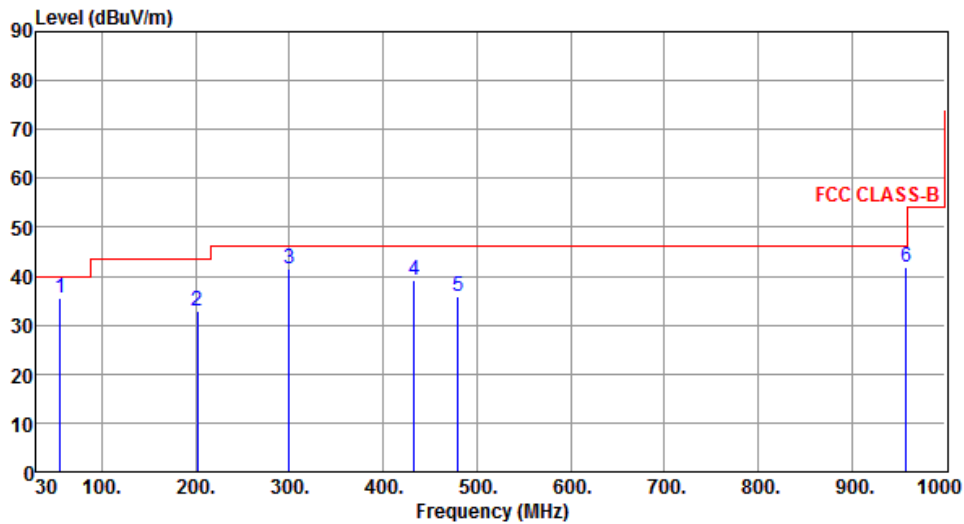

	Freq. MHz	Emission level dBuV/m	Limit dBuV/m	Margin dB	SA reading dBuV	Factor dB	Remark	ANT High cm	Turn Table deg
1	55.22	35.50	40.00	-4.50	52.42	-16.92	Peak	---	---
2	201.69	32.91	43.50	-10.59	52.18	-19.27	Peak	---	---
3	299.66	41.38	46.00	-4.62	57.63	-16.25	Peak	---	---
4	433.52	39.25	46.00	-6.75	52.09	-12.84	Peak	---	---
5	480.08	35.90	46.00	-10.10	47.88	-11.98	Peak	---	---
6	958.29	41.68	46.00	-4.32	46.45	-4.77	Peak	---	---

Note 1: Emission Level (dBuV/m) = SA Reading (dBuV/m) + Factor* (dB)

*Factor includes antenna factor , cable loss and amplifier gain

Note 2: Margin (dB) = Emission level (dBuV/m) – Limit (dBuV/m).



3.5.5 Transmitter Radiated Unwanted Emissions (Above 1GHz) for 11b

Modulation	11b	Test Freq. (MHz)	2412																																																																						
Polarization	Horizontal																																																																								
	<table border="1"> <thead> <tr> <th>Freq.</th> <th>Emission level</th> <th>Limit</th> <th>Margin</th> <th>SA reading</th> <th>Factor</th> <th>Remark</th> <th>ANT High</th> <th>Turn Table</th> </tr> <tr> <th>MHz</th> <th>dBuV/m</th> <th>dBuV/m</th> <th>dB</th> <th>dBuV</th> <th>dB</th> <th></th> <th>cm</th> <th>deg</th> </tr> </thead> <tbody> <tr> <td>1</td> <td>2313.00</td> <td>28.42</td> <td>54.00</td> <td>-25.58</td> <td>31.94</td> <td>-3.52</td> <td>Average</td> <td>---</td> </tr> <tr> <td>2</td> <td>2313.00</td> <td>42.97</td> <td>74.00</td> <td>-31.03</td> <td>46.49</td> <td>-3.52</td> <td>Peak</td> <td>---</td> </tr> <tr> <td>3</td> <td>2390.00</td> <td>32.50</td> <td>54.00</td> <td>-21.50</td> <td>35.72</td> <td>-3.22</td> <td>Average</td> <td>---</td> </tr> <tr> <td>4</td> <td>2390.00</td> <td>44.44</td> <td>74.00</td> <td>-29.56</td> <td>47.66</td> <td>-3.22</td> <td>Peak</td> <td>---</td> </tr> <tr> <td>5</td> <td>4824.00</td> <td>50.56</td> <td>54.00</td> <td>-3.44</td> <td>46.25</td> <td>4.31</td> <td>Average</td> <td>---</td> </tr> <tr> <td>6</td> <td>4824.00</td> <td>53.57</td> <td>74.00</td> <td>-20.43</td> <td>49.26</td> <td>4.31</td> <td>Peak</td> <td>---</td> </tr> </tbody> </table>	Freq.	Emission level	Limit	Margin	SA reading	Factor	Remark	ANT High	Turn Table	MHz	dBuV/m	dBuV/m	dB	dBuV	dB		cm	deg	1	2313.00	28.42	54.00	-25.58	31.94	-3.52	Average	---	2	2313.00	42.97	74.00	-31.03	46.49	-3.52	Peak	---	3	2390.00	32.50	54.00	-21.50	35.72	-3.22	Average	---	4	2390.00	44.44	74.00	-29.56	47.66	-3.22	Peak	---	5	4824.00	50.56	54.00	-3.44	46.25	4.31	Average	---	6	4824.00	53.57	74.00	-20.43	49.26	4.31	Peak	---
Freq.	Emission level	Limit	Margin	SA reading	Factor	Remark	ANT High	Turn Table																																																																	
MHz	dBuV/m	dBuV/m	dB	dBuV	dB		cm	deg																																																																	
1	2313.00	28.42	54.00	-25.58	31.94	-3.52	Average	---																																																																	
2	2313.00	42.97	74.00	-31.03	46.49	-3.52	Peak	---																																																																	
3	2390.00	32.50	54.00	-21.50	35.72	-3.22	Average	---																																																																	
4	2390.00	44.44	74.00	-29.56	47.66	-3.22	Peak	---																																																																	
5	4824.00	50.56	54.00	-3.44	46.25	4.31	Average	---																																																																	
6	4824.00	53.57	74.00	-20.43	49.26	4.31	Peak	---																																																																	
<p>Note 1: ">20dB" means spurious emission levels that exceed the level of 20 dB below the applicable limit.</p> <p>Note 2: For restricted bands, the peak measurement is fully sufficient, as the max field strength as measured with the Peak-Detector meets the AV-Limit so that the AV level does not need to be reported in addition.</p> <p>Note 3: For un-restricted bands, unwanted emissions shall be attenuated by at least 20 dB relative to the maximum measured in-band level.</p>																																																																									



Modulation	11b	Test Freq. (MHz)	2412
Polarization	Vertical		

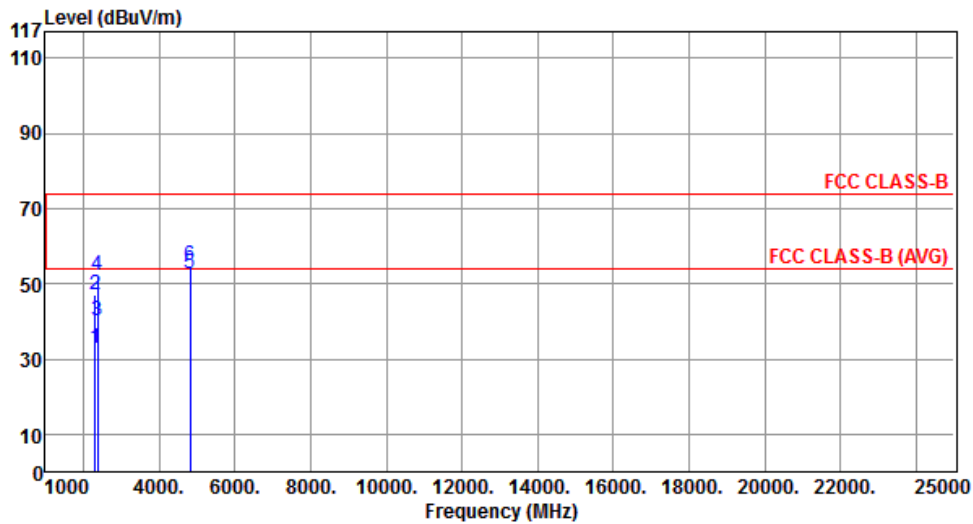

	Freq. MHz	Emission level dBuV/m	Limit dBuV/m	Margin dB	SA reading dBuV	Factor dB	Remark	ANT High cm	Turn Table deg
1	2313.00	32.66	54.00	-21.34	36.18	-3.52	Average	---	---
2	2313.00	47.02	74.00	-26.98	50.54	-3.52	Peak	---	---
3	2390.00	40.32	54.00	-13.68	43.54	-3.22	Average	---	---
4	2390.00	52.16	74.00	-21.84	55.38	-3.22	Peak	---	---
5	4824.00	52.64	54.00	-1.36	48.33	4.31	Average	---	---
6	4824.00	54.90	74.00	-19.10	50.59	4.31	Peak	---	---

Note 1: ">20dB" means spurious emission levels that exceed the level of 20 dB below the applicable limit.

Note 2: For restricted bands, the peak measurement is fully sufficient, as the max field strength as measured with the Peak-Detector meets the AV-Limit so that the AV level does not need to be reported in addition.

Note 3: For un-restricted bands, unwanted emissions shall be attenuated by at least 20 dB relative to the maximum measured in-band level.



Modulation	11b	Test Freq. (MHz)	2437
Polarization	Horizontal		

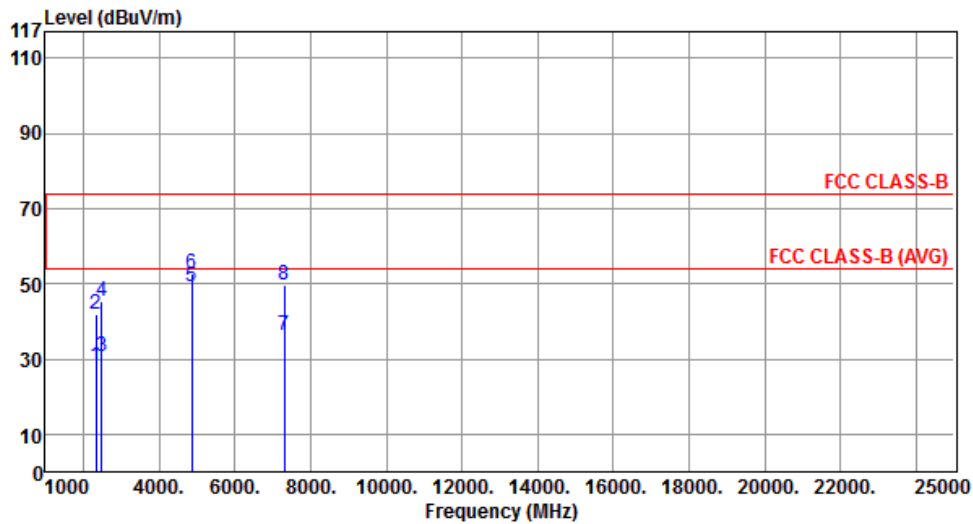

	Freq. MHz	Emission level dBuV/m	Limit dBuV/m	Margin dB	SA reading dBuV	Factor dB	Remark	ANT High cm	Turn Table deg
1	2335.00	28.20	54.00	-25.80	31.63	-3.43	Average	---	---
2	2335.00	41.76	74.00	-32.24	45.19	-3.43	Peak	---	---
3	2483.50	30.86	54.00	-23.14	33.69	-2.83	Average	---	---
4	2483.50	45.22	74.00	-28.78	48.05	-2.83	Peak	---	---
5	4874.00	49.27	54.00	-4.73	44.88	4.39	Average	---	---
6	4874.00	52.48	74.00	-21.52	48.09	4.39	Peak	---	---
7	7311.00	36.39	54.00	-17.61	27.47	8.92	Average	---	---
8	7311.00	49.79	74.00	-24.21	40.87	8.92	Peak	---	---

Note 1: ">20dB" means spurious emission levels that exceed the level of 20 dB below the applicable limit.

Note 2: For restricted bands, the peak measurement is fully sufficient, as the max field strength as measured with the Peak-Detector meets the AV-Limit so that the AV level does not need to be reported in addition.

Note 3: For un-restricted bands, unwanted emissions shall be attenuated by at least 20 dB relative to the maximum measured in-band level.



Modulation	11b	Test Freq. (MHz)	2437
Polarization	Vertical		

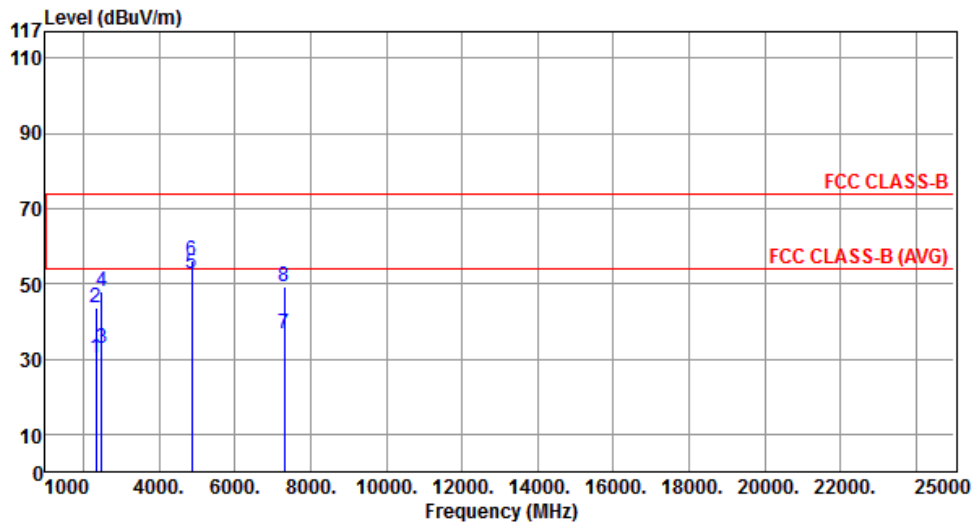

	Freq. MHz	Emission level dBuV/m	Limit dBuV/m	Margin dB	SA reading dBuV	Factor dB	Remark	ANT High cm	Turn Table deg
1	2335.00	30.14	54.00	-23.86	33.57	-3.43	Average	---	---
2	2335.00	43.62	74.00	-30.38	47.05	-3.43	Peak	---	---
3	2483.50	32.67	54.00	-21.33	35.50	-2.83	Average	---	---
4	2483.50	47.72	74.00	-26.28	50.55	-2.83	Peak	---	---
5	4874.00	52.76	54.00	-1.24	48.37	4.39	Average	---	---
6	4874.00	55.93	74.00	-18.07	51.54	4.39	Peak	---	---
7	7311.00	36.85	54.00	-17.15	27.93	8.92	Average	---	---
8	7311.00	49.24	74.00	-24.76	40.32	8.92	Peak	---	---

Note 1: ">20dB" means spurious emission levels that exceed the level of 20 dB below the applicable limit.

Note 2: For restricted bands, the peak measurement is fully sufficient, as the max field strength as measured with the Peak-Detector meets the AV-Limit so that the AV level does not need to be reported in addition.

Note 3: For un-restricted bands, unwanted emissions shall be attenuated by at least 20 dB relative to the maximum measured in-band level.



Modulation	11b	Test Freq. (MHz)	2462
Polarization	Horizontal		

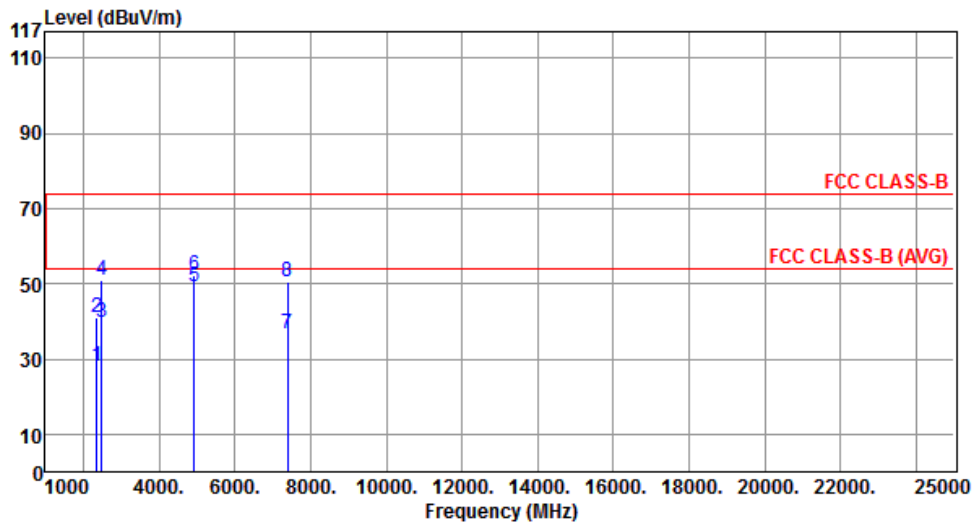

	Freq. MHz	Emission level dBuV/m	Limit dBuV/m	Margin dB	SA reading dBuV	Factor dB	Remark	ANT High cm	Turn Table deg
1	2359.00	28.07	54.00	-25.93	31.41	-3.34	Average	---	---
2	2359.00	41.00	74.00	-33.00	44.34	-3.34	Peak	---	---
3	2483.50	39.73	54.00	-14.27	42.56	-2.83	Average	---	---
4	2483.50	51.06	74.00	-22.94	53.89	-2.83	Peak	---	---
5	4924.00	49.31	54.00	-4.69	44.83	4.48	Average	---	---
6	4924.00	52.29	74.00	-21.71	47.81	4.48	Peak	---	---
7	7386.00	36.77	54.00	-17.23	27.79	8.98	Average	---	---
8	7386.00	50.30	74.00	-23.70	41.32	8.98	Peak	---	---

Note 1: ">20dB" means spurious emission levels that exceed the level of 20 dB below the applicable limit.

Note 2: For restricted bands, the peak measurement is fully sufficient, as the max field strength as measured with the Peak-Detector meets the AV-Limit so that the AV level does not need to be reported in addition.

Note 3: For un-restricted bands, unwanted emissions shall be attenuated by at least 20 dB relative to the maximum measured in-band level.



Modulation	11b	Test Freq. (MHz)	2462
Polarization	Vertical		

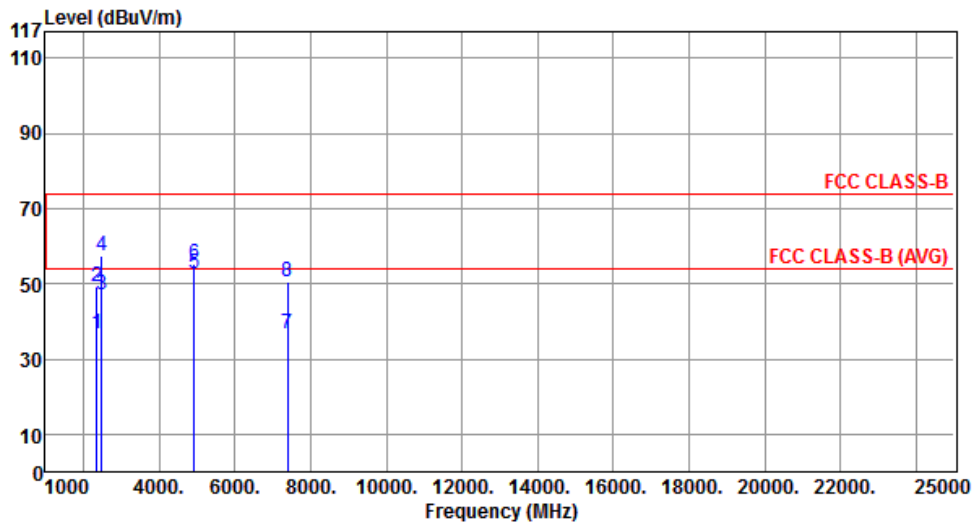

	Freq. MHz	Emission level dBuV/m	Limit dBuV/m	Margin dB	SA reading dBuV	Factor dB	Remark	ANT High cm	Turn Table deg
1	2359.00	36.55	54.00	-17.45	39.89	-3.34	Average	---	---
2	2359.00	49.16	74.00	-24.84	52.50	-3.34	Peak	---	---
3	2483.50	46.98	54.00	-7.02	49.81	-2.83	Average	---	---
4	2483.50	57.42	74.00	-16.58	60.25	-2.83	Peak	---	---
5	4924.00	52.62	54.00	-1.38	48.14	4.48	Average	---	---
6	4924.00	55.34	74.00	-18.66	50.86	4.48	Peak	---	---
7	7386.00	36.63	54.00	-17.37	27.65	8.98	Average	---	---
8	7386.00	50.38	74.00	-23.62	41.40	8.98	Peak	---	---

Note 1: ">20dB" means spurious emission levels that exceed the level of 20 dB below the applicable limit.
 Note 2: For restricted bands, the peak measurement is fully sufficient, as the max field strength as measured with the Peak-Detector meets the AV-Limit so that the AV level does not need to be reported in addition.
 Note 3: For un-restricted bands, unwanted emissions shall be attenuated by at least 20 dB relative to the maximum measured in-band level.



3.5.6 Transmitter Radiated Unwanted Emissions (Above 1GHz) for 11g

Modulation	11g	Test Freq. (MHz)	2412						
Polarization	Horizontal								
	Freq. MHz	Emission level dBuV/m	Limit dBuV/m	Margin dB	SA reading dBuV	Factor dB	Remark	ANT High cm	Turn Table deg
1	2313.00	28.21	54.00	-25.79	31.73	-3.52	Average	---	---
2	2313.00	42.60	74.00	-31.40	46.12	-3.52	Peak	---	---
3	2390.00	43.64	54.00	-10.36	46.86	-3.22	Average	---	---
4	2390.00	63.49	74.00	-10.51	66.71	-3.22	Peak	---	---
5	4824.00	33.04	54.00	-20.96	28.73	4.31	Average	---	---
6	4824.00	46.92	74.00	-27.08	42.61	4.31	Peak	---	---
<p>Note 1: ">20dB" means spurious emission levels that exceed the level of 20 dB below the applicable limit.</p> <p>Note 2: For restricted bands, the peak measurement is fully sufficient, as the max field strength as measured with the Peak-Detector meets the AV-Limit so that the AV level does not need to be reported in addition.</p> <p>Note 3: For un-restricted bands, unwanted emissions shall be attenuated by at least 20 dB relative to the maximum measured in-band level.</p>									



Modulation	11g	Test Freq. (MHz)	2412
Polarization	Vertical		

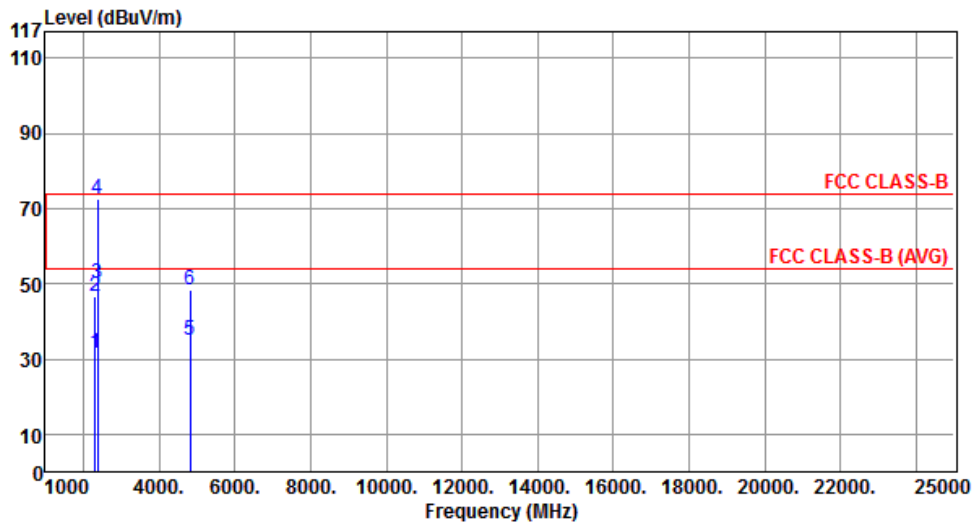

	Freq. MHz	Emission level dBuV/m	Limit dBuV/m	Margin dB	SA reading dBuV	Factor dB	Remark	ANT High cm	Turn Table deg
1	2313.00	31.64	54.00	-22.36	35.16	-3.52	Average	---	---
2	2313.00	46.51	74.00	-27.49	50.03	-3.52	Peak	---	---
3	2390.00	50.23	54.00	-3.77	53.45	-3.22	Average	---	---
4	2390.00	72.60	74.00	-1.40	75.82	-3.22	Peak	---	---
5	4824.00	35.17	54.00	-18.83	30.86	4.31	Average	---	---
6	4824.00	48.18	74.00	-25.82	43.87	4.31	Peak	---	---

Note 1: ">20dB" means spurious emission levels that exceed the level of 20 dB below the applicable limit.
 Note 2: For restricted bands, the peak measurement is fully sufficient, as the max field strength as measured with the Peak-Detector meets the AV-Limit so that the AV level does not need to be reported in addition.
 Note 3: For un-restricted bands, unwanted emissions shall be attenuated by at least 20 dB relative to the maximum measured in-band level.



Modulation	11g	Test Freq. (MHz)	2437
Polarization	Horizontal		

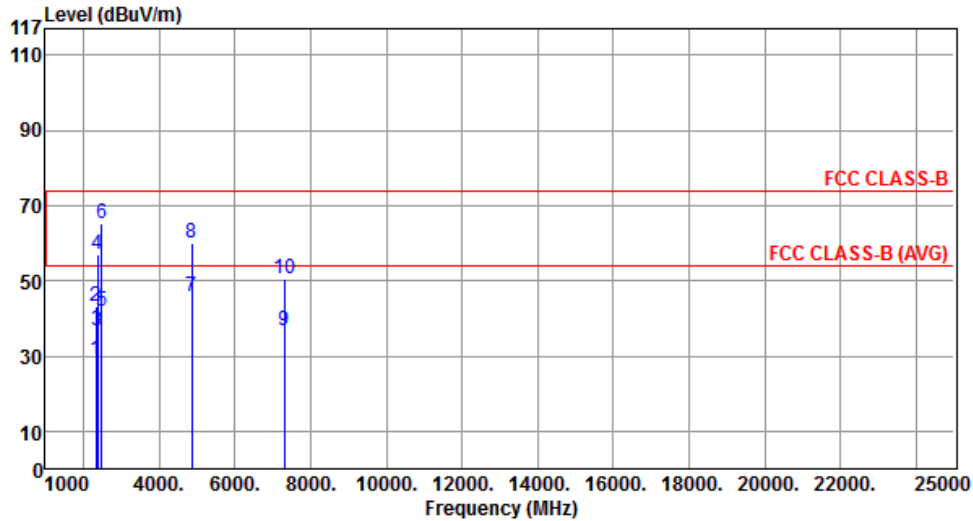

	Freq. MHz	Emission level dBuV/m	Limit dBuV/m	Margin dB	SA reading dBuV	Factor dB	Remark	ANT High cm	Turn Table deg
1	2335.00	29.06	54.00	-24.94	32.49	-3.43	Average	---	---
2	2335.00	43.28	74.00	-30.72	46.71	-3.43	Peak	---	---
3	2390.00	36.67	54.00	-17.33	39.89	-3.22	Average	---	---
4	2390.00	57.16	74.00	-16.84	60.38	-3.22	Peak	---	---
5	2483.50	41.95	54.00	-12.05	44.78	-2.83	Average	---	---
6	2483.50	65.39	74.00	-8.61	68.22	-2.83	Peak	---	---
7	4874.00	45.75	54.00	-8.25	41.36	4.39	Average	---	---
8	4874.00	60.02	74.00	-13.98	55.63	4.39	Peak	---	---
9	7311.00	36.86	54.00	-17.14	27.94	8.92	Average	---	---
10	7311.00	50.40	74.00	-23.60	41.48	8.92	Peak	---	---

Note 1: ">20dB" means spurious emission levels that exceed the level of 20 dB below the applicable limit.
 Note 2: For restricted bands, the peak measurement is fully sufficient, as the max field strength as measured with the Peak-Detector meets the AV-Limit so that the AV level does not need to be reported in addition.
 Note 3: For un-restricted bands, unwanted emissions shall be attenuated by at least 20 dB relative to the maximum measured in-band level.



Modulation	11g	Test Freq. (MHz)	2437
Polarization	Vertical		

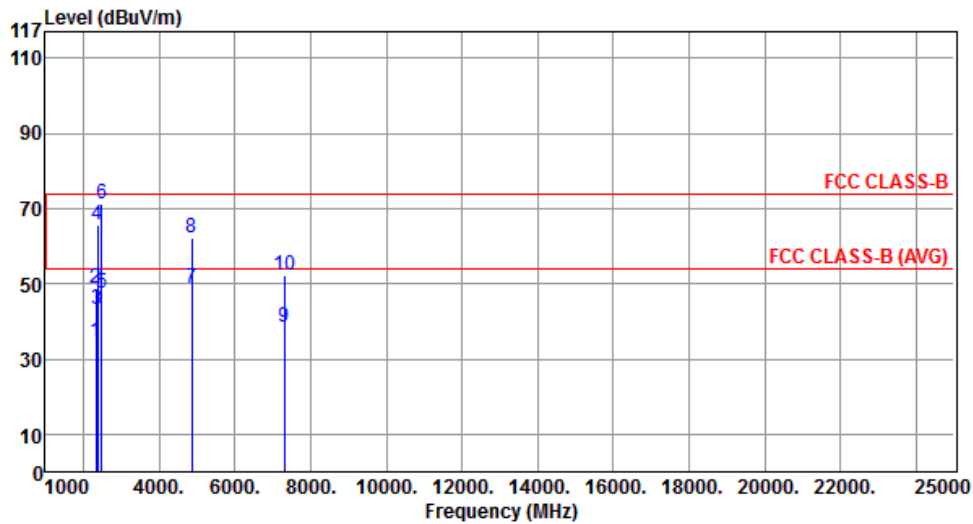

	Freq. MHz	Emission level dBuV/m	Limit dBuV/m	Margin dB	SA reading dBuV	Factor dB	Remark	ANT High cm	Turn Table deg
1	2335.00	34.49	54.00	-19.51	37.92	-3.43	Average	---	---
2	2335.00	48.71	74.00	-25.29	52.14	-3.43	Peak	---	---
3	2390.00	43.14	54.00	-10.86	46.36	-3.22	Average	---	---
4	2390.00	65.72	74.00	-8.28	68.94	-3.22	Peak	---	---
5	2483.50	47.36	54.00	-6.64	50.19	-2.83	Average	---	---
6	2483.50	71.25	74.00	-2.75	74.08	-2.83	Peak	---	---
7	4874.00	48.91	54.00	-5.09	44.52	4.39	Average	---	---
8	4874.00	62.32	74.00	-11.68	57.93	4.39	Peak	---	---
9	7311.00	38.42	54.00	-15.58	29.50	8.92	Average	---	---
10	7311.00	52.28	74.00	-21.72	43.36	8.92	Peak	---	---

Note 1: ">20dB" means spurious emission levels that exceed the level of 20 dB below the applicable limit.

Note 2: For restricted bands, the peak measurement is fully sufficient, as the max field strength as measured with the Peak-Detector meets the AV-Limit so that the AV level does not need to be reported in addition.

Note 3: For un-restricted bands, unwanted emissions shall be attenuated by at least 20 dB relative to the maximum measured in-band level.



Modulation	11g	Test Freq. (MHz)	2462
Polarization	Horizontal		

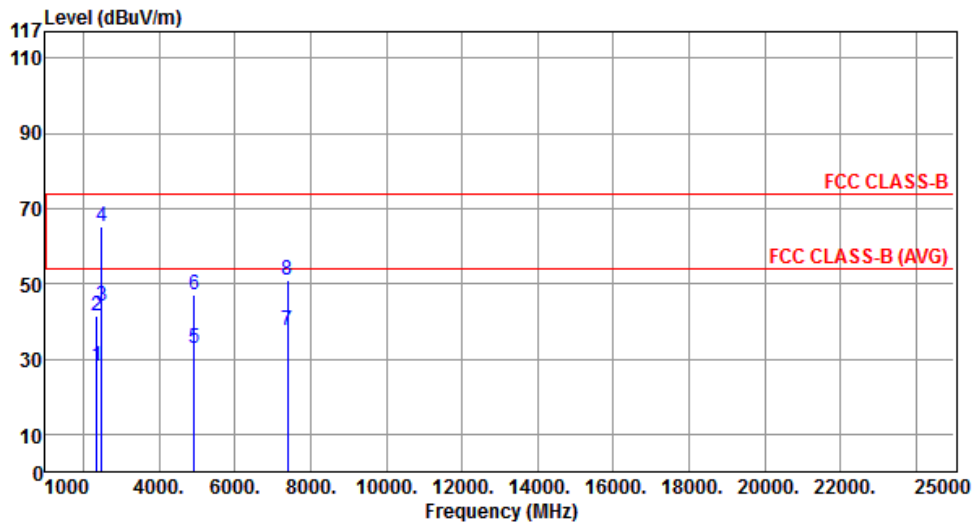

	Freq. MHz	Emission level dBuV/m	Limit dBuV/m	Margin dB	SA reading dBuV	Factor dB	Remark	ANT High cm	Turn Table deg
1	2359.00	28.13	54.00	-25.87	31.47	-3.34	Average	---	---
2	2359.00	41.44	74.00	-32.56	44.78	-3.34	Peak	---	---
3	2483.50	43.89	54.00	-10.11	46.72	-2.83	Average	---	---
4	2483.50	65.29	74.00	-8.71	68.12	-2.83	Peak	---	---
5	4924.00	32.79	54.00	-21.21	28.31	4.48	Average	---	---
6	4924.00	47.05	74.00	-26.95	42.57	4.48	Peak	---	---
7	7386.00	37.55	54.00	-16.45	28.57	8.98	Average	---	---
8	7386.00	50.94	74.00	-23.06	41.96	8.98	Peak	---	---

Note 1: ">20dB" means spurious emission levels that exceed the level of 20 dB below the applicable limit.
 Note 2: For restricted bands, the peak measurement is fully sufficient, as the max field strength as measured with the Peak-Detector meets the AV-Limit so that the AV level does not need to be reported in addition.
 Note 3: For un-restricted bands, unwanted emissions shall be attenuated by at least 20 dB relative to the maximum measured in-band level.



Modulation	11g	Test Freq. (MHz)	2462
Polarization	Vertical		

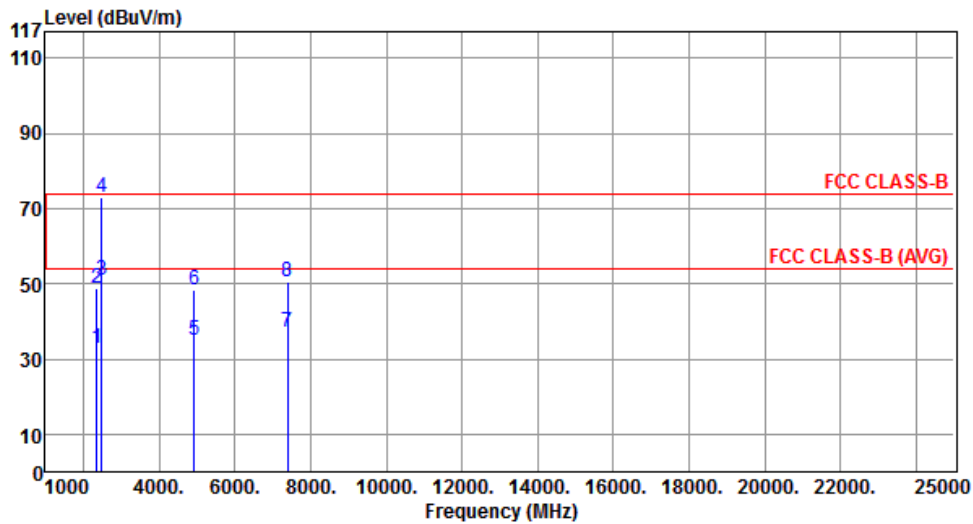

	Freq. MHz	Emission level dBuV/m	Limit dBuV/m	Margin dB	SA reading dBuV	Factor dB	Remark	ANT High cm	Turn Table deg
1	2359.00	32.72	54.00	-21.28	36.06	-3.34	Average	---	---
2	2359.00	48.61	74.00	-25.39	51.95	-3.34	Peak	---	---
3	2483.50	51.07	54.00	-2.93	53.90	-2.83	Average	---	---
4	2483.50	72.98	74.00	-1.02	75.81	-2.83	Peak	---	---
5	4924.00	35.12	54.00	-18.88	30.64	4.48	Average	---	---
6	4924.00	48.29	74.00	-25.71	43.81	4.48	Peak	---	---
7	7386.00	37.23	54.00	-16.77	28.25	8.98	Average	---	---
8	7386.00	50.64	74.00	-23.36	41.66	8.98	Peak	---	---

Note 1: ">20dB" means spurious emission levels that exceed the level of 20 dB below the applicable limit.

Note 2: For restricted bands, the peak measurement is fully sufficient, as the max field strength as measured with the Peak-Detector meets the AV-Limit so that the AV level does not need to be reported in addition.

Note 3: For un-restricted bands, unwanted emissions shall be attenuated by at least 20 dB relative to the maximum measured in-band level.



3.5.7 Transmitter Radiated Unwanted Emissions (Above 1GHz) for HT20

Modulation	HT20	Test Freq. (MHz)	2412
Polarization	Horizontal		

The graph displays the radiated unwanted emissions for HT20. The y-axis represents the level in dBuV/m, ranging from 0 to 117. The x-axis represents the frequency in MHz, ranging from 1000 to 25000. Two horizontal red lines indicate the FCC CLASS-B limit at approximately 74 dBuV/m and the FCC CLASS-B (AVG) limit at approximately 54 dBuV/m. Three peaks are identified: Peak 4 at 2313 MHz (45.30 dBuV/m), Peak 5 at 2390 MHz (61.35 dBuV/m), and Peak 6 at 4824 MHz (32.66 dBuV/m). All peaks are well below the FCC CLASS-B limit.

	Freq. MHz	Emission level dBuV/m	Limit dBuV/m	Margin dB	SA reading dBuV	Factor dB	Remark	ANT High cm	Turn Table deg
1	2313.00	27.76	54.00	-26.24	31.28	-3.52	Average	---	---
2	2313.00	45.30	74.00	-28.70	48.82	-3.52	Peak	---	---
3	2390.00	43.53	54.00	-10.47	46.75	-3.22	Average	---	---
4	2390.00	61.35	74.00	-12.65	64.57	-3.22	Peak	---	---
5	4824.00	32.66	54.00	-21.34	28.35	4.31	Average	---	---
6	4824.00	46.78	74.00	-27.22	42.47	4.31	Peak	---	---

Note 1: ">20dB" means spurious emission levels that exceed the level of 20 dB below the applicable limit.
 Note 2: For restricted bands, the peak measurement is fully sufficient, as the max field strength as measured with the Peak-Detector meets the AV-Limit so that the AV level does not need to be reported in addition.
 Note 3: For un-restricted bands, unwanted emissions shall be attenuated by at least 20 dB relative to the maximum measured in-band level.



Modulation	HT20	Test Freq. (MHz)	2412
Polarization	Vertical		

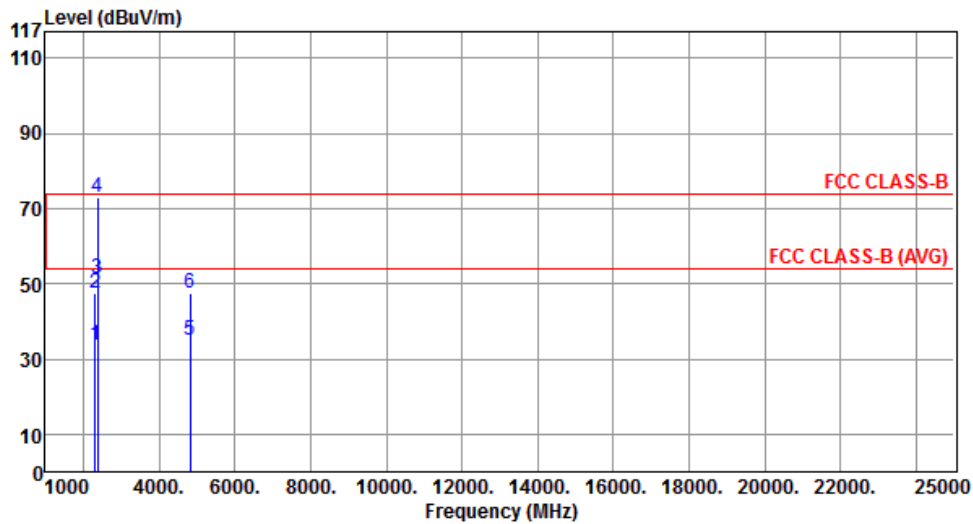

	Freq. MHz	Emission level dBuV/m	Limit dBuV/m	Margin dB	SA reading dBuV	Factor dB	Remark	ANT High cm	Turn Table deg
1	2313.00	33.61	54.00	-20.39	37.13	-3.52	Average	---	---
2	2313.00	47.68	74.00	-26.32	51.20	-3.52	Peak	---	---
3	2390.00	51.31	54.00	-2.69	54.53	-3.22	Average	---	---
4	2390.00	72.89	74.00	-1.11	76.11	-3.22	Peak	---	---
5	4824.00	34.89	54.00	-19.11	30.58	4.31	Average	---	---
6	4824.00	47.48	74.00	-26.52	43.17	4.31	Peak	---	---

Note 1: ">20dB" means spurious emission levels that exceed the level of 20 dB below the applicable limit.

Note 2: For restricted bands, the peak measurement is fully sufficient, as the max field strength as measured with the Peak-Detector meets the AV-Limit so that the AV level does not need to be reported in addition.

Note 3: For un-restricted bands, unwanted emissions shall be attenuated by at least 20 dB relative to the maximum measured in-band level.



Modulation	HT20	Test Freq. (MHz)	2437
Polarization	Horizontal		

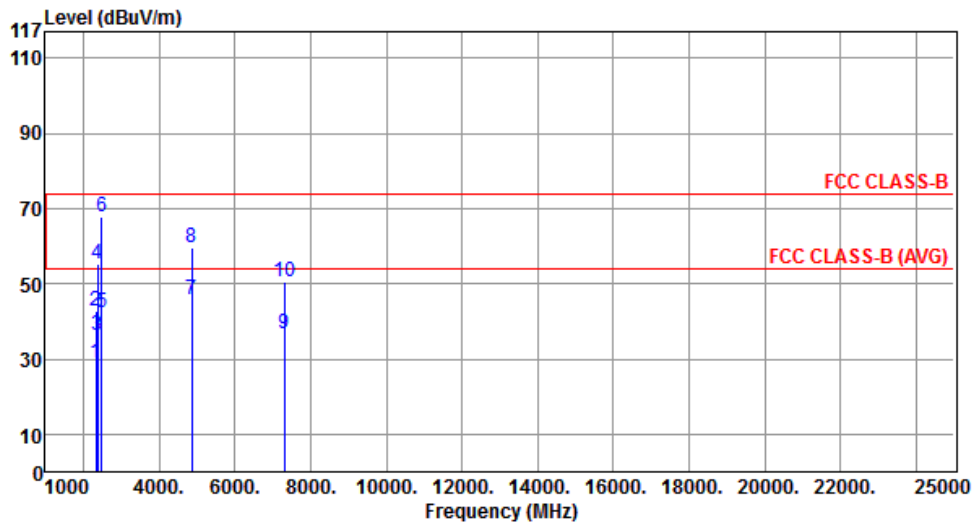

	Freq. MHz	Emission level dBuV/m	Limit dBuV/m	Margin dB	SA reading dBuV	Factor dB	Remark	ANT High cm	Turn Table deg
1	2335.00	28.73	54.00	-25.27	32.16	-3.43	Average	---	---
2	2335.00	42.59	74.00	-31.41	46.02	-3.43	Peak	---	---
3	2390.00	36.09	54.00	-17.91	39.31	-3.22	Average	---	---
4	2390.00	55.26	74.00	-18.74	58.48	-3.22	Peak	---	---
5	2483.50	42.25	54.00	-11.75	45.08	-2.83	Average	---	---
6	2483.50	67.79	74.00	-6.21	70.62	-2.83	Peak	---	---
7	4874.00	45.66	54.00	-8.34	41.27	4.39	Average	---	---
8	4874.00	59.77	74.00	-14.23	55.38	4.39	Peak	---	---
9	7311.00	36.60	54.00	-17.40	27.68	8.92	Average	---	---
10	7311.00	50.64	74.00	-23.36	41.72	8.92	Peak	---	---

Note 1: ">20dB" means spurious emission levels that exceed the level of 20 dB below the applicable limit.

Note 2: For restricted bands, the peak measurement is fully sufficient, as the max field strength as measured with the Peak-Detector meets the AV-Limit so that the AV level does not need to be reported in addition.

Note 3: For un-restricted bands, unwanted emissions shall be attenuated by at least 20 dB relative to the maximum measured in-band level.



Modulation	HT20	Test Freq. (MHz)	2437
Polarization	Vertical		

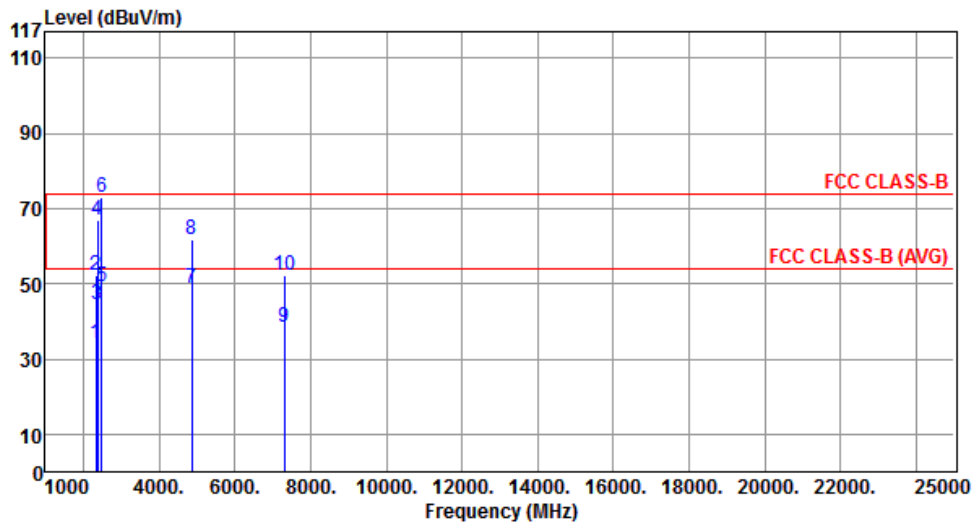

	Freq. MHz	Emission level dBuV/m	Limit dBuV/m	Margin dB	SA reading dBuV	Factor dB	Remark	ANT High cm	Turn Table deg
1	2335.00	34.20	54.00	-19.80	37.63	-3.43	Average	---	---
2	2335.00	52.35	74.00	-21.65	55.78	-3.43	Peak	---	---
3	2390.00	44.44	54.00	-9.56	47.66	-3.22	Average	---	---
4	2390.00	66.74	74.00	-7.26	69.96	-3.22	Peak	---	---
5	2483.50	49.24	54.00	-4.76	52.07	-2.83	Average	---	---
6	2483.50	72.86	74.00	-1.14	75.69	-2.83	Peak	---	---
7	4874.00	48.76	54.00	-5.24	44.37	4.39	Average	---	---
8	4874.00	61.91	74.00	-12.09	57.52	4.39	Peak	---	---
9	7311.00	38.53	54.00	-15.47	29.61	8.92	Average	---	---
10	7311.00	52.38	74.00	-21.62	43.46	8.92	Peak	---	---

Note 1: ">20dB" means spurious emission levels that exceed the level of 20 dB below the applicable limit.

Note 2: For restricted bands, the peak measurement is fully sufficient, as the max field strength as measured with the Peak-Detector meets the AV-Limit so that the AV level does not need to be reported in addition.

Note 3: For un-restricted bands, unwanted emissions shall be attenuated by at least 20 dB relative to the maximum measured in-band level.



Modulation	HT20	Test Freq. (MHz)	2462
Polarization	Horizontal		

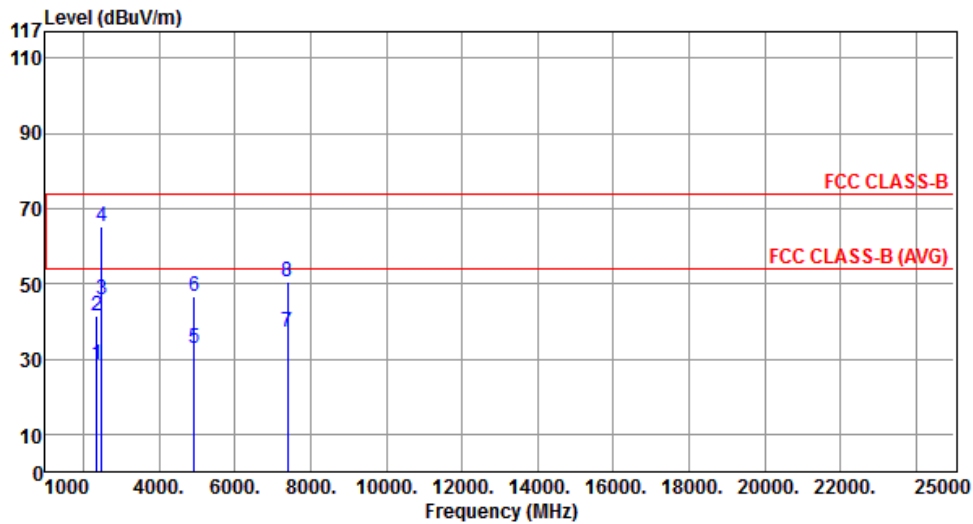

	Freq. MHz	Emission level dBuV/m	Limit dBuV/m	Margin dB	SA reading dBuV	Factor dB	Remark	ANT High cm	Turn Table deg
1	2359.00	28.52	54.00	-25.48	31.86	-3.34	Average	---	---
2	2359.00	41.64	74.00	-32.36	44.98	-3.34	Peak	---	---
3	2483.50	45.87	54.00	-8.13	48.70	-2.83	Average	---	---
4	2483.50	65.26	74.00	-8.74	68.09	-2.83	Peak	---	---
5	4924.00	32.76	54.00	-21.24	28.28	4.48	Average	---	---
6	4924.00	46.77	74.00	-27.23	42.29	4.48	Peak	---	---
7	7386.00	37.24	54.00	-16.76	28.26	8.98	Average	---	---
8	7386.00	50.53	74.00	-23.47	41.55	8.98	Peak	---	---

Note 1: ">20dB" means spurious emission levels that exceed the level of 20 dB below the applicable limit.

Note 2: For restricted bands, the peak measurement is fully sufficient, as the max field strength as measured with the Peak-Detector meets the AV-Limit so that the AV level does not need to be reported in addition.

Note 3: For un-restricted bands, unwanted emissions shall be attenuated by at least 20 dB relative to the maximum measured in-band level.



Modulation	HT20	Test Freq. (MHz)	2462
Polarization	Vertical		

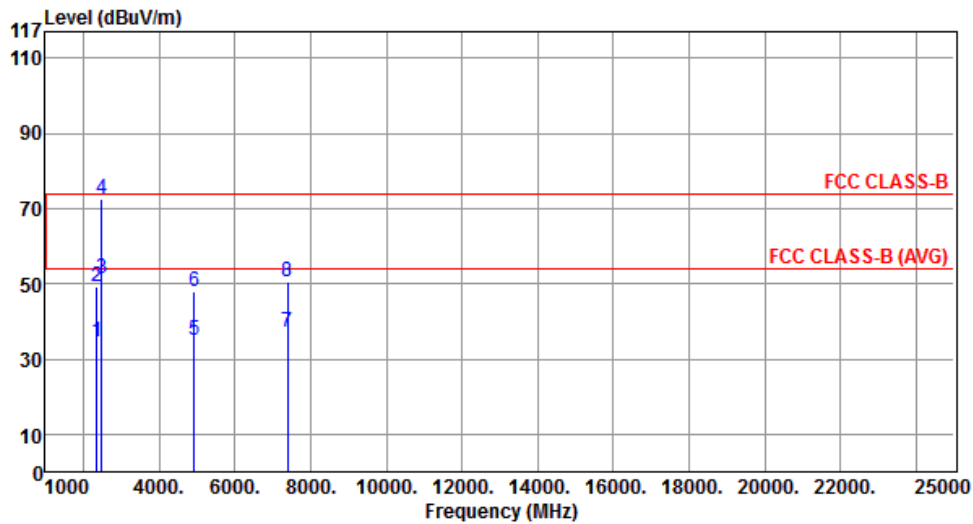

	Freq. MHz	Emission level dBuV/m	Limit dBuV/m	Margin dB	SA reading dBuV	Factor dB	Remark	ANT High cm	Turn Table deg
1	2359.00	34.34	54.00	-19.66	37.68	-3.34	Average	---	---
2	2359.00	49.08	74.00	-24.92	52.42	-3.34	Peak	---	---
3	2483.50	51.44	54.00	-2.56	54.27	-2.83	Average	---	---
4	2483.50	72.68	74.00	-1.32	75.51	-2.83	Peak	---	---
5	4924.00	34.94	54.00	-19.06	30.46	4.48	Average	---	---
6	4924.00	48.12	74.00	-25.88	43.64	4.48	Peak	---	---
7	7386.00	37.11	54.00	-16.89	28.13	8.98	Average	---	---
8	7386.00	50.46	74.00	-23.54	41.48	8.98	Peak	---	---

Note 1: ">20dB" means spurious emission levels that exceed the level of 20 dB below the applicable limit.

Note 2: For restricted bands, the peak measurement is fully sufficient, as the max field strength as measured with the Peak-Detector meets the AV-Limit so that the AV level does not need to be reported in addition.

Note 3: For un-restricted bands, unwanted emissions shall be attenuated by at least 20 dB relative to the maximum measured in-band level.



3.5.8 Transmitter Radiated Unwanted Emissions (Above 1GHz) for HT40

Modulation	HT40	Test Freq. (MHz)	2422
Polarization	Horizontal		

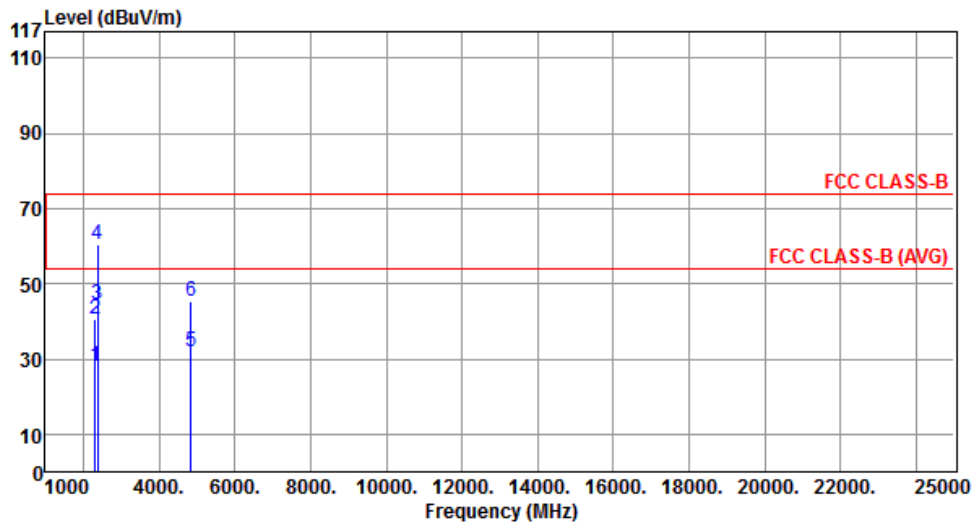

	Freq. MHz	Emission level dBuV/m	Limit dBuV/m	Margin dB	SA reading dBuV	Factor dB	Remark	ANT High cm	Turn Table deg
1	2326.00	27.88	54.00	-26.12	31.35	-3.47	Average	---	---
2	2326.00	40.66	74.00	-33.34	44.13	-3.47	Peak	---	---
3	2390.00	44.54	54.00	-9.46	47.76	-3.22	Average	---	---
4	2390.00	60.43	74.00	-13.57	63.65	-3.22	Peak	---	---
5	4844.00	31.93	54.00	-22.07	27.59	4.34	Average	---	---
6	4844.00	45.18	74.00	-28.82	40.84	4.34	Peak	---	---

Note 1: ">20dB" means spurious emission levels that exceed the level of 20 dB below the applicable limit.
 Note 2: For restricted bands, the peak measurement is fully sufficient, as the max field strength as measured with the Peak-Detector meets the AV-Limit so that the AV level does not need to be reported in addition.
 Note 3: For un-restricted bands, unwanted emissions shall be attenuated by at least 20 dB relative to the maximum measured in-band level.



Modulation	HT40	Test Freq. (MHz)	2422
Polarization	Vertical		

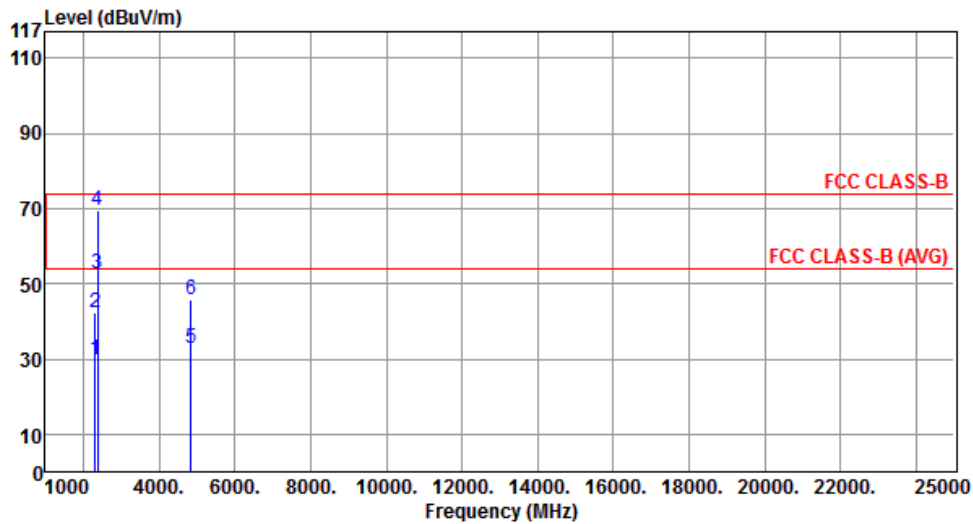

	Freq. MHz	Emission level dBuV/m	Limit dBuV/m	Margin dB	SA reading dBuV	Factor dB	Remark	ANT High cm	Turn Table deg
1	2326.00	29.68	54.00	-24.32	33.15	-3.47	Average	---	---
2	2326.00	42.16	74.00	-31.84	45.63	-3.47	Peak	---	---
3	2390.00	52.75	54.00	-1.25	55.97	-3.22	Average	---	---
4	2390.00	69.44	74.00	-4.56	72.66	-3.22	Peak	---	---
5	4844.00	33.01	54.00	-20.99	28.67	4.34	Average	---	---
6	4844.00	45.56	74.00	-28.44	41.22	4.34	Peak	---	---

Note 1: ">20dB" means spurious emission levels that exceed the level of 20 dB below the applicable limit.

Note 2: For restricted bands, the peak measurement is fully sufficient, as the max field strength as measured with the Peak-Detector meets the AV-Limit so that the AV level does not need to be reported in addition.

Note 3: For un-restricted bands, unwanted emissions shall be attenuated by at least 20 dB relative to the maximum measured in-band level.



Modulation	HT40	Test Freq. (MHz)	2437
Polarization	Horizontal		

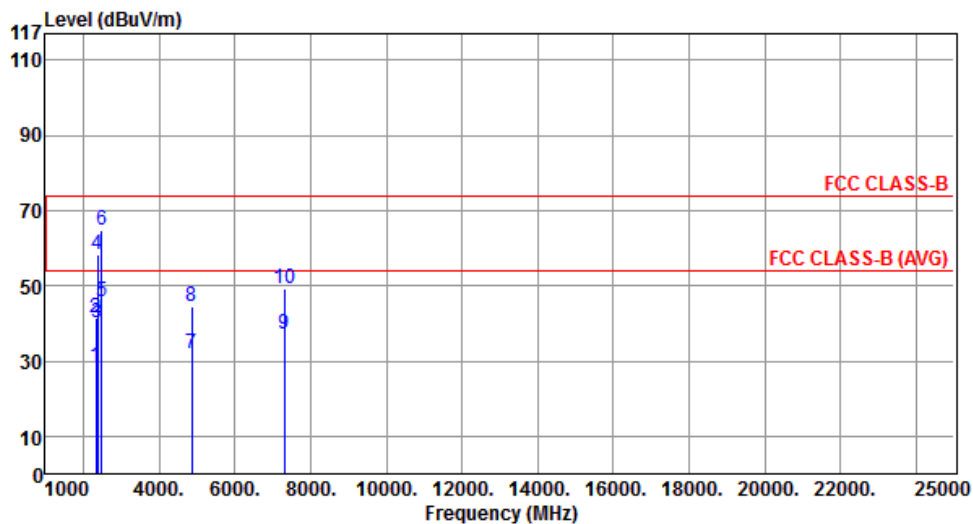

	Freq. MHz	Emission level dBuV/m	Limit dBuV/m	Margin dB	SA reading dBuV	Factor dB	Remark	ANT High cm	Turn Table deg
1	2335.00	28.68	54.00	-25.32	32.11	-3.43	Average	---	---
2	2335.00	41.62	74.00	-32.38	45.05	-3.43	Peak	---	---
3	2390.00	40.13	54.00	-13.87	43.35	-3.22	Average	---	---
4	2390.00	58.47	74.00	-15.53	61.69	-3.22	Peak	---	---
5	2483.50	45.87	54.00	-8.13	48.70	-2.83	Average	---	---
6	2483.50	64.58	74.00	-9.42	67.41	-2.83	Peak	---	---
7	4874.00	31.91	54.00	-22.09	27.52	4.39	Average	---	---
8	4874.00	44.54	74.00	-29.46	40.15	4.39	Peak	---	---
9	7311.00	37.15	54.00	-16.85	28.23	8.92	Average	---	---
10	7311.00	49.41	74.00	-24.59	40.49	8.92	Peak	---	---

Note 1: ">20dB" means spurious emission levels that exceed the level of 20 dB below the applicable limit.
 Note 2: For restricted bands, the peak measurement is fully sufficient, as the max field strength as measured with the Peak-Detector meets the AV-Limit so that the AV level does not need to be reported in addition.
 Note 3: For un-restricted bands, unwanted emissions shall be attenuated by at least 20 dB relative to the maximum measured in-band level.



Modulation	HT40	Test Freq. (MHz)	2437
Polarization	Vertical		

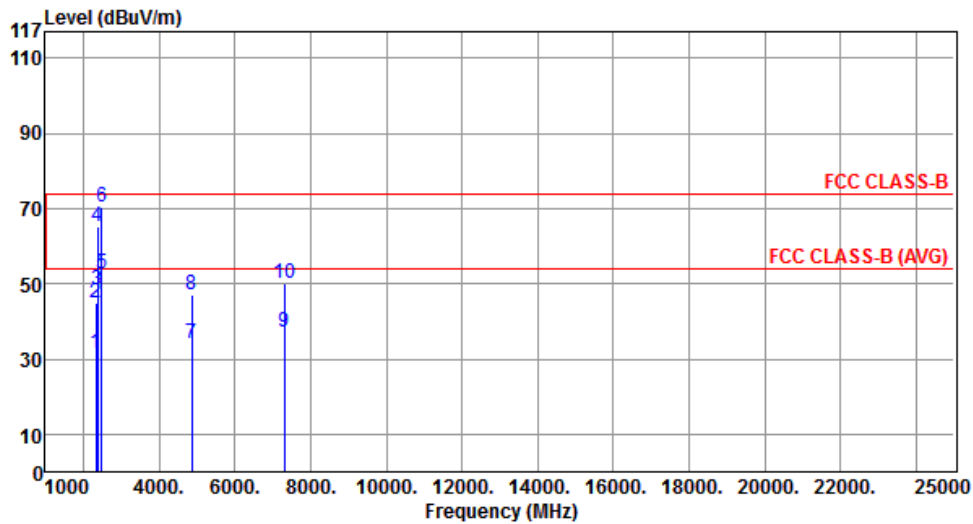

	Freq. MHz	Emission level dBuV/m	Limit dBuV/m	Margin dB	SA reading dBuV	Factor dB	Remark	ANT High cm	Turn Table deg
1	2335.00	31.46	54.00	-22.54	34.89	-3.43	Average	---	---
2	2335.00	44.79	74.00	-29.21	48.22	-3.43	Peak	---	---
3	2390.00	48.40	54.00	-5.60	51.62	-3.22	Average	---	---
4	2390.00	65.37	74.00	-8.63	68.59	-3.22	Peak	---	---
5	2483.50	52.87	54.00	-1.13	55.70	-2.83	Average	---	---
6	2483.50	70.27	74.00	-3.73	73.10	-2.83	Peak	---	---
7	4874.00	33.90	54.00	-20.10	29.51	4.39	Average	---	---
8	4874.00	46.94	74.00	-27.06	42.55	4.39	Peak	---	---
9	7311.00	37.06	54.00	-16.94	28.14	8.92	Average	---	---
10	7311.00	49.89	74.00	-24.11	40.97	8.92	Peak	---	---

Note 1: ">20dB" means spurious emission levels that exceed the level of 20 dB below the applicable limit.
 Note 2: For restricted bands, the peak measurement is fully sufficient, as the max field strength as measured with the Peak-Detector meets the AV-Limit so that the AV level does not need to be reported in addition.
 Note 3: For un-restricted bands, unwanted emissions shall be attenuated by at least 20 dB relative to the maximum measured in-band level.



Modulation	HT40	Test Freq. (MHz)	2452
Polarization	Horizontal		

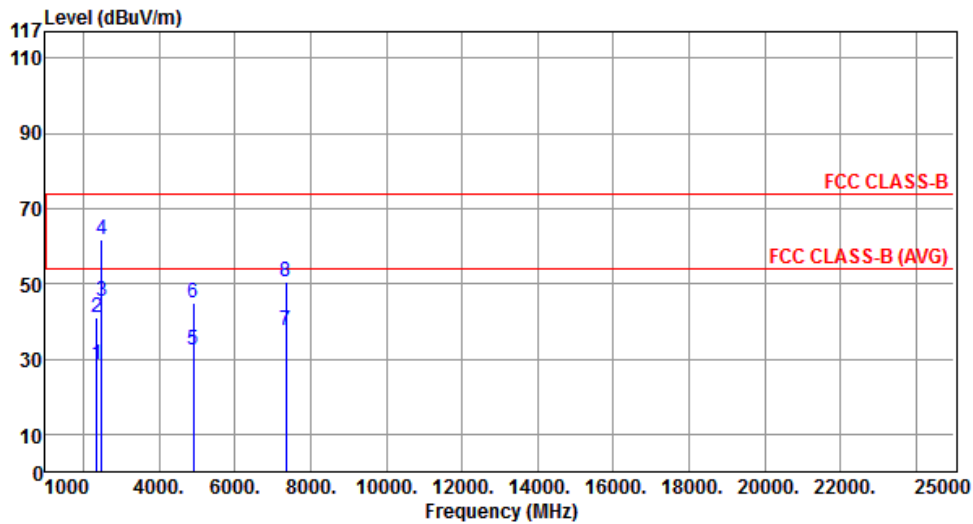

	Freq. MHz	Emission level dBuV/m	Limit dBuV/m	Margin dB	SA reading dBuV	Factor dB	Remark	ANT High cm	Turn Table deg
1	2364.00	28.70	54.00	-25.30	32.02	-3.32	Average	---	---
2	2364.00	40.84	74.00	-33.16	44.16	-3.32	Peak	---	---
3	2483.50	45.50	54.00	-8.50	48.33	-2.83	Average	---	---
4	2483.50	61.66	74.00	-12.34	64.49	-2.83	Peak	---	---
5	4904.00	32.34	54.00	-21.66	27.89	4.45	Average	---	---
6	4904.00	44.93	74.00	-29.07	40.48	4.45	Peak	---	---
7	7356.00	37.39	54.00	-16.61	28.43	8.96	Average	---	---
8	7356.00	50.43	74.00	-23.57	41.47	8.96	Peak	---	---

Note 1: ">20dB" means spurious emission levels that exceed the level of 20 dB below the applicable limit.

Note 2: For restricted bands, the peak measurement is fully sufficient, as the max field strength as measured with the Peak-Detector meets the AV-Limit so that the AV level does not need to be reported in addition.

Note 3: For un-restricted bands, unwanted emissions shall be attenuated by at least 20 dB relative to the maximum measured in-band level.



Modulation	HT40	Test Freq. (MHz)	2452
Polarization	Vertical		

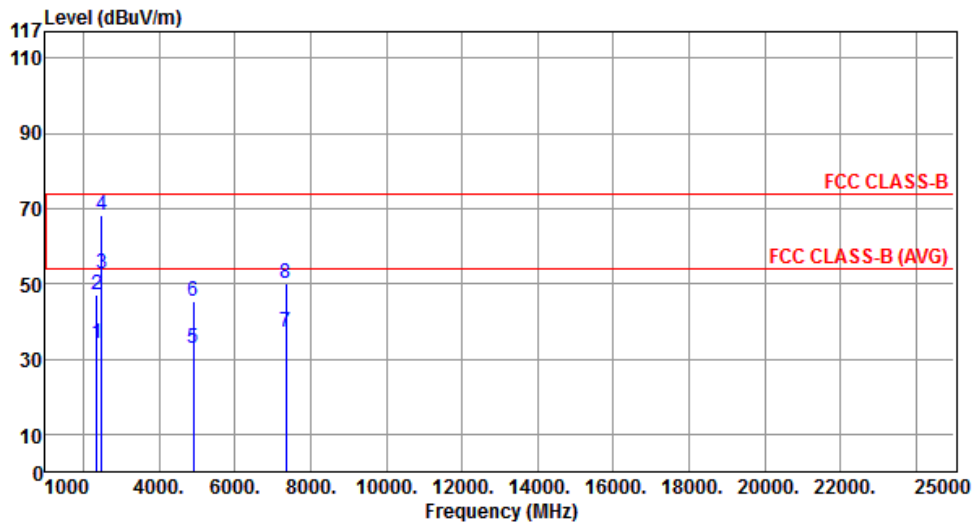

	Freq. MHz	Emission level dBuV/m	Limit dBuV/m	Margin dB	SA reading dBuV	Factor dB	Remark	ANT High cm	Turn Table deg
1	2364.00	34.07	54.00	-19.93	37.39	-3.32	Average	---	---
2	2364.00	46.98	74.00	-27.02	50.30	-3.32	Peak	---	---
3	2483.50	52.79	54.00	-1.21	55.62	-2.83	Average	---	---
4	2483.50	68.32	74.00	-5.68	71.15	-2.83	Peak	---	---
5	4904.00	32.97	54.00	-21.03	28.52	4.45	Average	---	---
6	4904.00	45.31	74.00	-28.69	40.86	4.45	Peak	---	---
7	7356.00	37.08	54.00	-16.92	28.12	8.96	Average	---	---
8	7356.00	50.26	74.00	-23.74	41.30	8.96	Peak	---	---

Note 1: ">20dB" means spurious emission levels that exceed the level of 20 dB below the applicable limit.

Note 2: For restricted bands, the peak measurement is fully sufficient, as the max field strength as measured with the Peak-Detector meets the AV-Limit so that the AV level does not need to be reported in addition.

Note 3: For un-restricted bands, unwanted emissions shall be attenuated by at least 20 dB relative to the maximum measured in-band level.



3.6 Unwanted Emissions into Non-Restricted Frequency Bands

3.6.1 Limit of Unwanted Emissions into Non-Restricted Frequency Bands

- The peak output power measured in any 100 kHz bandwidth outside of the authorized frequency band shall be attenuated by at least 20 dB relative to the maximum in-band peak PSD level in 100 kHz.
- The peak power in any 100 kHz bandwidth outside of the authorized frequency band shall be attenuated by at least 30 dB relative to the maximum in-band peak PSD level in 100 kHz.

3.6.2 Test Procedures

Reference Level Measurement

1. Set the RBW = 100 kHz, VBW = 300 kHz, Detector = peak.
2. Set Sweep time = auto couple, Trace mode = max hold.
3. Allow trace to fully stabilize.
4. Use the peak marker function to determine the maximum amplitude level.

Unwanted Emissions Level Measurement

1. Set RBW = 100 kHz, VBW = 300 kHz, Detector = peak.
2. Trace Mode = max hold, Sweep = auto couple.
3. Allow the trace to stabilize.
4. Use peak marker function to determine maximum amplitude of all unwanted emissions within any 100 kHz bandwidth.

3.6.3 Test Setup

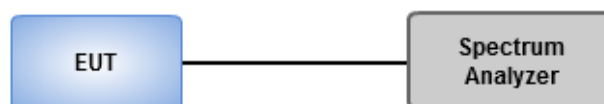

3.6.4 Unwanted Emissions into Non-Restricted Frequency Bands

This test item is performed on each TX output individually without summing or adding $10 \log(N_{ANT})$ since measurements are made relative to the in-band emissions on the individual outputs. Only worst test result of each operating mode is presented.



802.11b

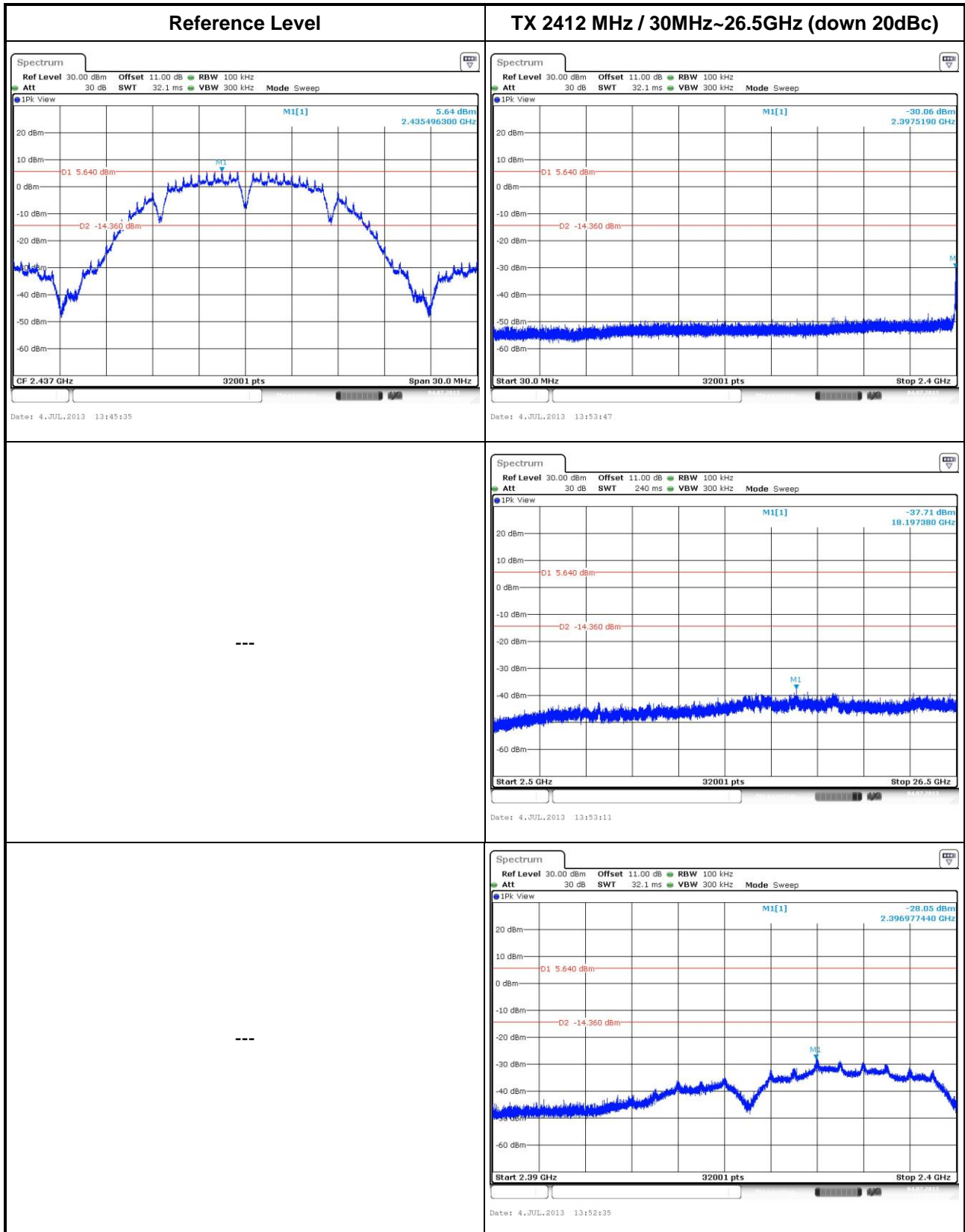

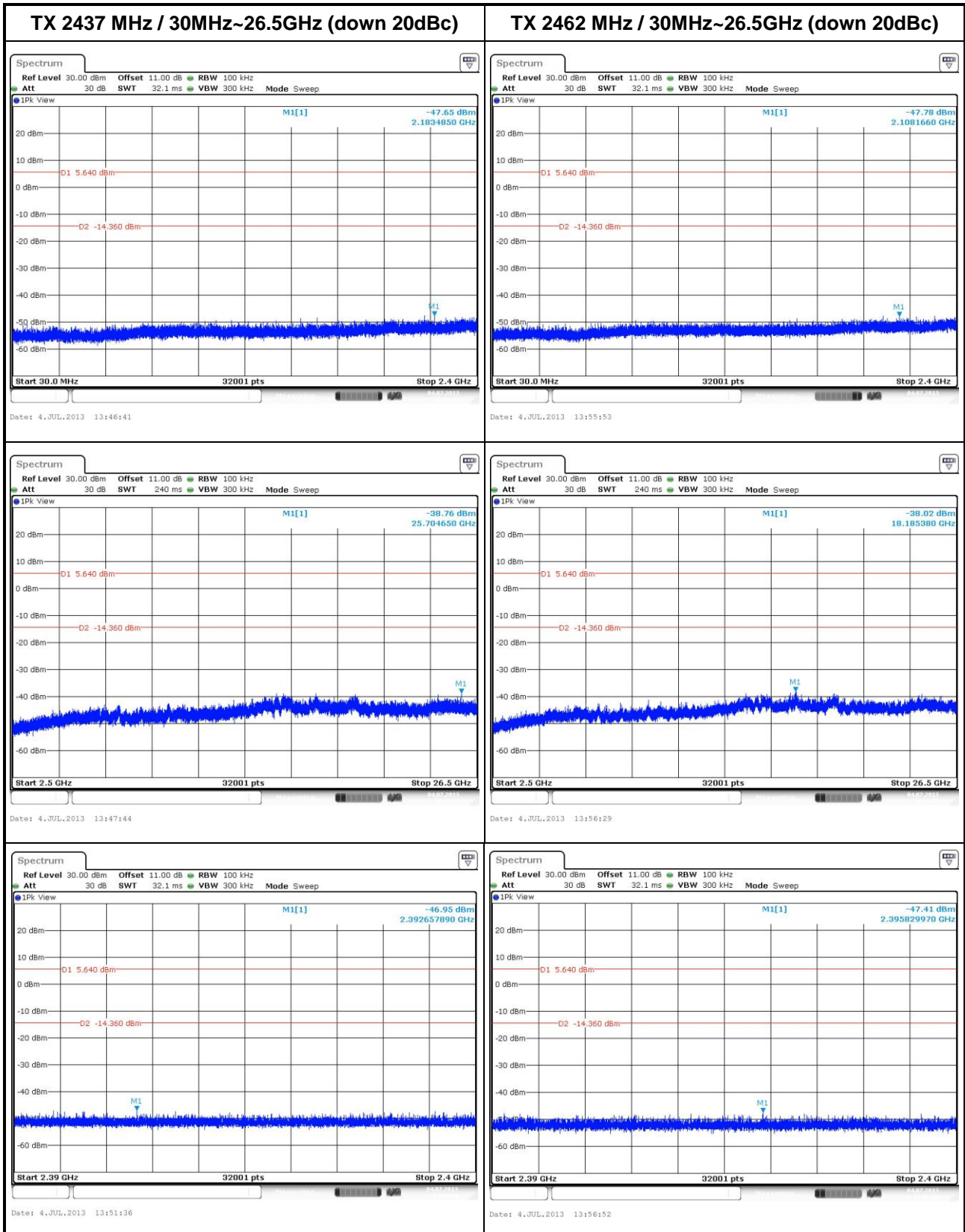



802.11g

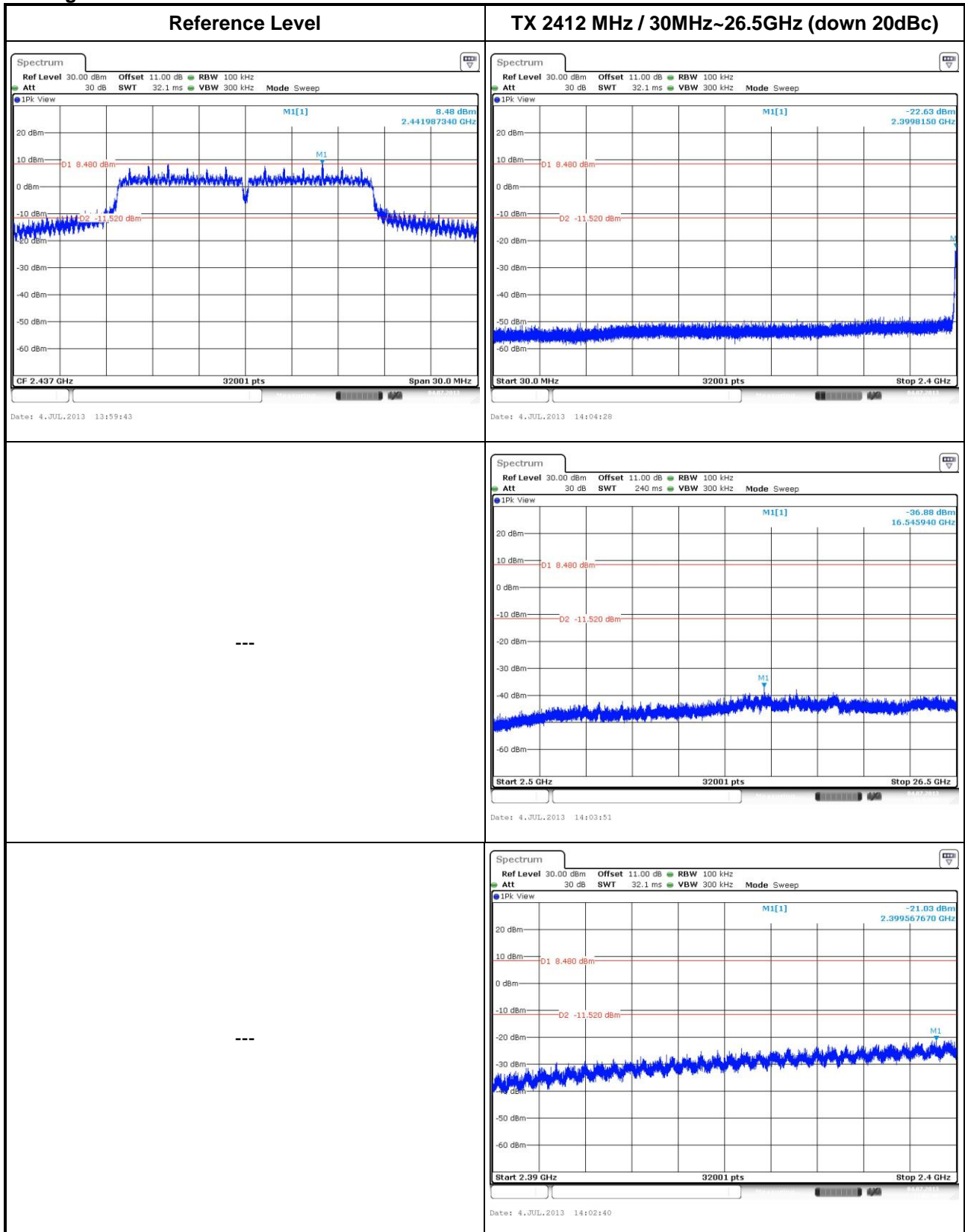

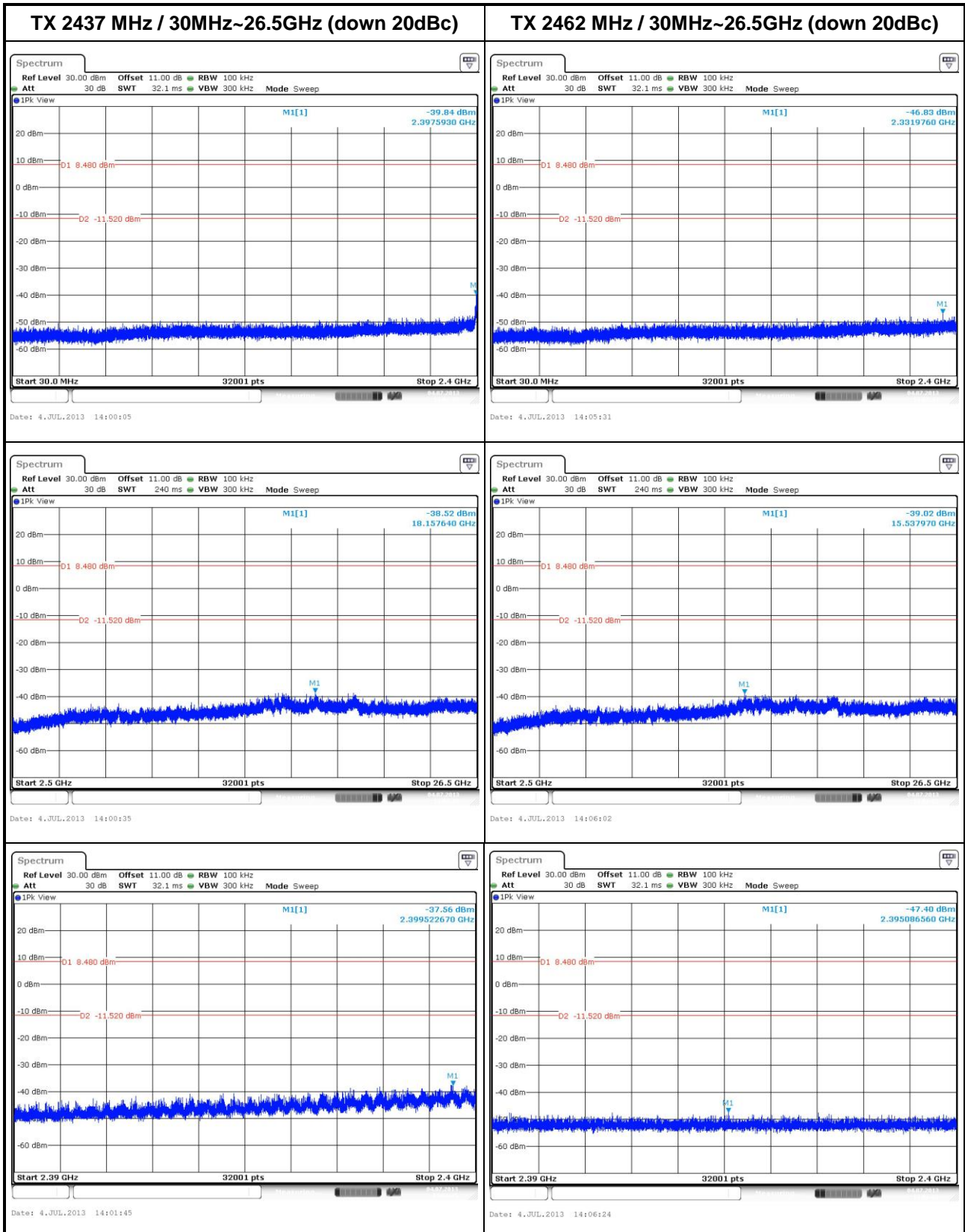



802.11n HT20

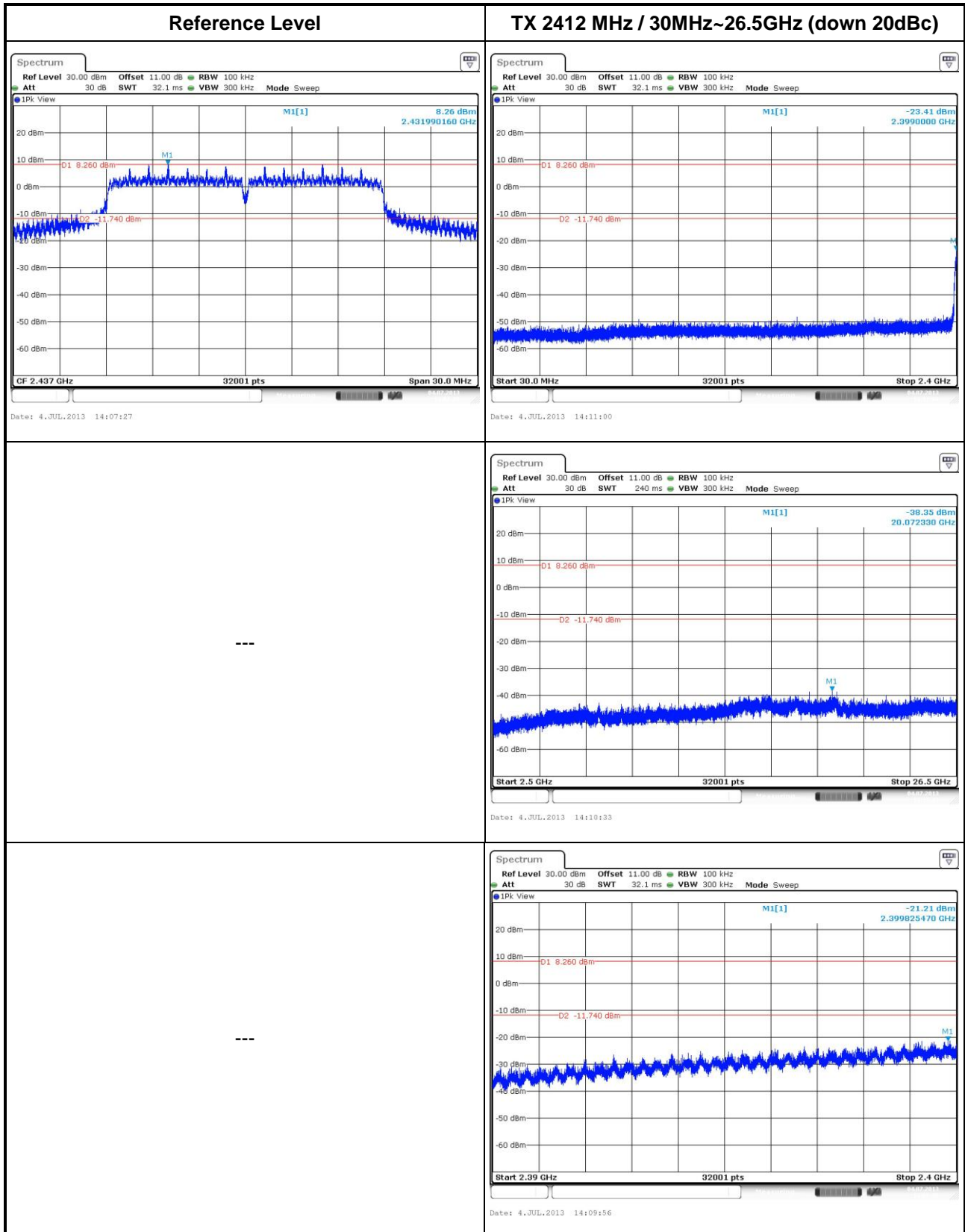

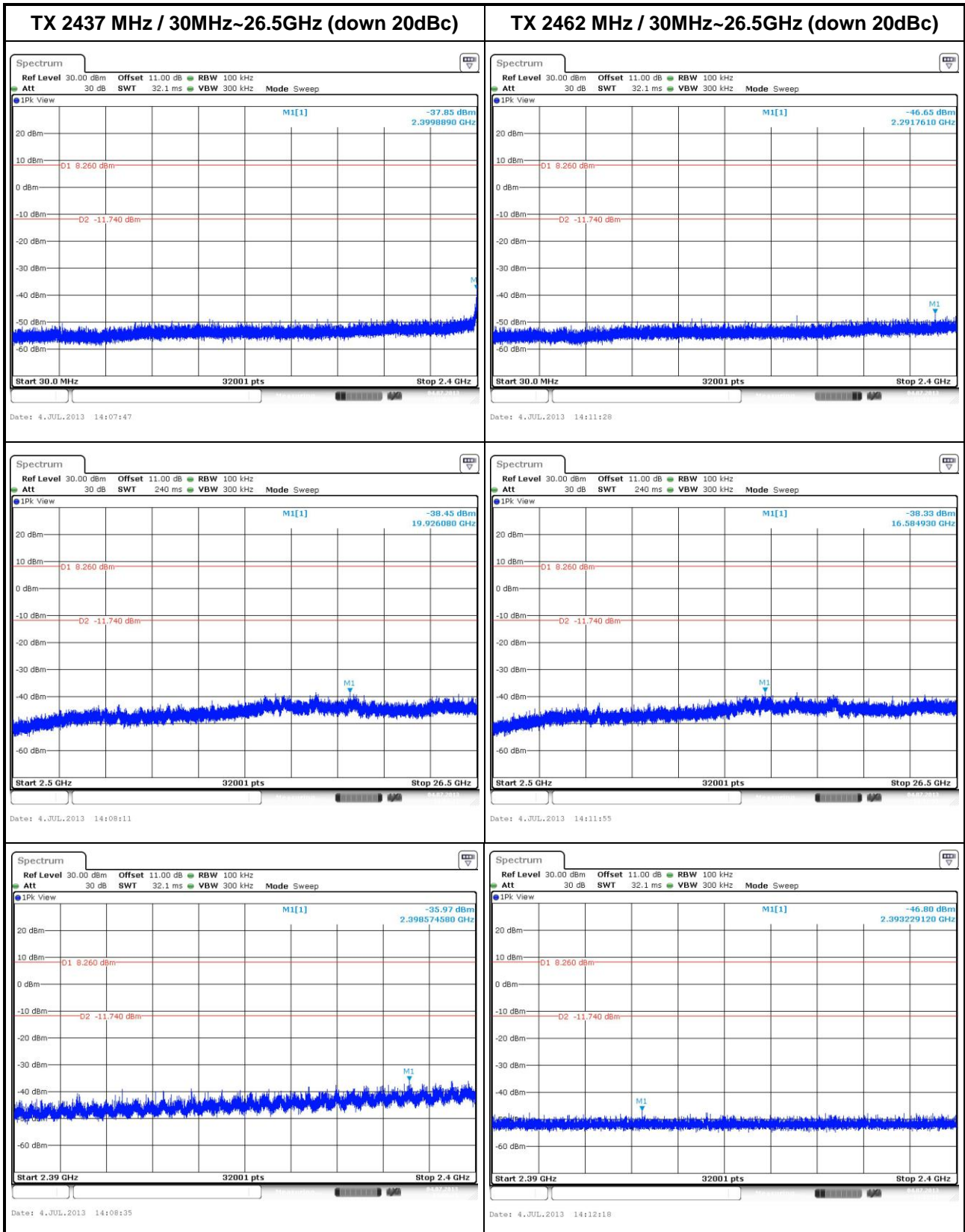



802.11n HT40

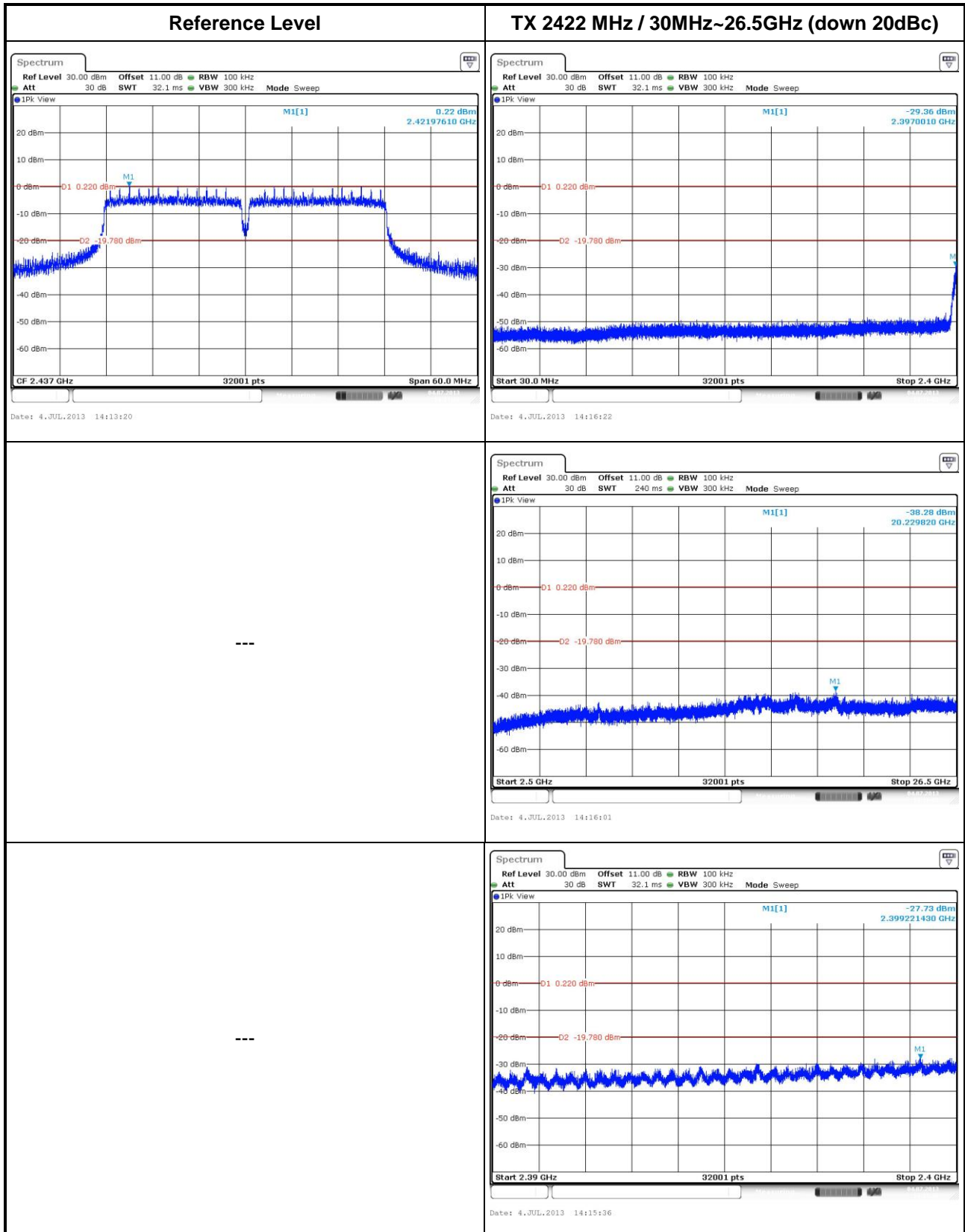

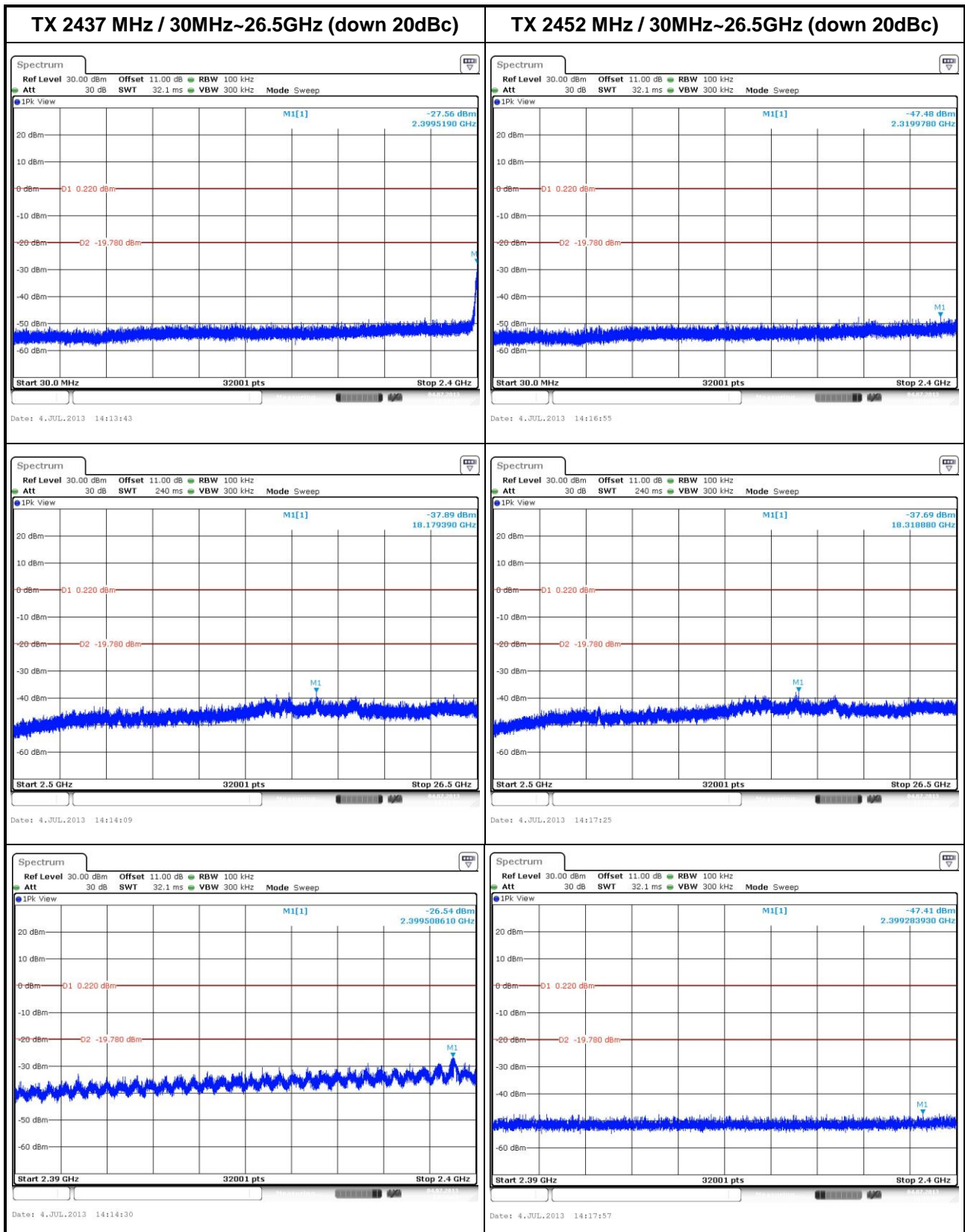

==END==