



Karaoke Wireless Mic
+ Built-in Speaker
Operation Manual DG-KRK

FCC ID: 2AANZKRK2-
BT ID: D051448
MADE IN CHINA

Thank you for purchasing the Vibe™ Wireless Karaoke Wireless Mic/Speaker & Speaker. Please read all instructions carefully before using and retain this manual for future use and reference.

PACKAGE CONTENTS

- Karaoke Wireless Mic/Speaker
- Micro USB Charging Cable
- Operation Manual

KEY FEATURES

- Compatible with Bluetooth®-enabled devices
- Built-in rechargeable battery
- Built-in speaker
- Volume and echo control

SAFETY INSTRUCTIONS

Keep the unit away from heat sources, direct sunlight, humidity, water and any other liquids.

Do not operate the unit if it has been exposed to water, moisture or any other liquids to prevent against electric shock, explosion and/or injury to yourself and damage to the unit.

Do not use the unit if it has been dropped or damaged in any way.

Repairs to electrical equipment should only be performed by the manufacturer. Improper repairs may place the user at serious risk.

Do not puncture or harm the exterior surface of the product in any way.

Keep the unit free from dust, lint, etc.

Do not use this unit for anything other than its intended use or purpose. Doing so may damage the device.

This product is not a toy. Keep out of reach of children.

Do not expose batteries, battery pack, or batteries to installed to excessive heat, such as direct sunlight, or open flame.

DIAGRAM

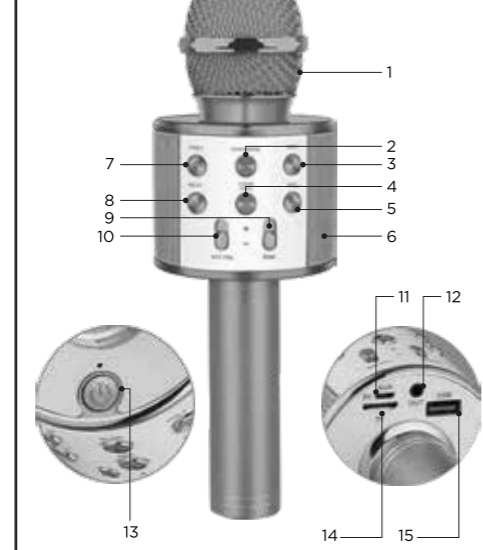

- | | |
|---------------------|------------------------------|
| 1. Microphone | 9. Echo Switch |
| 2. Play/Pause | 10. Microphone Volume Switch |
| 3. Volume Up | 11. Micro USB Charge Port |
| 4. Funny Voice | 12. 3.5mm Audio Out Port |
| 5. Volume Down | 13. On/off switch |
| 6. Built-in Speaker | 14. Micro TF Card Port |
| 7. Previous Track | 15. USB Media Port |
| 8. Next Track | |

CHARGING THE KARAOKE WIRELESS MIC/SPEAKER

The Karaoke Wireless Mic/Speaker comes with a built-in rechargeable battery. Before using it for the first time, we recommend you charge the battery fully. Only use the supplied charge cable to charge the speaker.

Connect the USB end to a computer USB port or a USB wall charger and the micro USB to the charge port on the karaoke mic. The red LED indicator will illuminate while the Karaoke Wireless Mic/Speaker is charging.

A full charge of the battery takes around 2.5 hours. When the battery is fully charged, the LED indicator will turn off. Disconnect the Karaoke Wireless Mic/Speaker at this point. The Karaoke Wireless Mic/Speaker will then be ready for use.

When the battery is low, the LED indicator will flash red and emit three tones every 20 seconds. When this occurs, please recharge the karaoke mic. When using your Karaoke Wireless Mic/Speaker with an iPhone, the top right corner will indicate your karaoke mic's battery life.

PROMPT NOTIFICATION

- The Karaoke Wireless Mic/Speaker will notify you during "Power On" with the sound of a beep.
- The Karaoke Wireless Mic/Speaker will notify you during "Power off" with a prompt tone.
- The Karaoke Wireless Mic/Speaker will notify you when "Pairing Successful" with the sound of a beep.

PAIRING THE KARAOKE MIC/SPEAKER

1. Ensure the Karaoke Wireless Mic/Speaker is turned off. If it is not, please turn off the Karaoke Wireless Mic/Speaker first before pairing.
2. Press and hold the multifunction button for 3 seconds until the blue LED indicator flashes. This will indicate your Karaoke Wireless Mic/Speaker is now in pairing mode.
3. Place the Karaoke Wireless Mic/Speaker and the Bluetooth® device to which you would like to pair it within the operating distance. We recommend keeping the two devices no further than 3 feet apart.
4. Ensure Bluetooth is enabled on your device. Refer to the manufacturer's instructions for how to enable Bluetooth on your device.

5. Once you have activated Bluetooth on your device, select the Karaoke Wireless Mic/Speaker "DG-KRK" from the list of available Bluetooth devices.
6. If required, enter the PIN code "0000" and confirm the entry.

Note: If pairing is unsuccessful, turn off the Karaoke Wireless Mic/Speaker first and re-pair following the aforementioned steps. Once you have paired the Karaoke Wireless Mic/Speaker with a device, the Karaoke Wireless Mic/Speaker will remember this device and will pair automatically when the device's Bluetooth is activated and in range. You do not need to re-pair any previously connected devices.

TWO WAYS CONNECTION

Bluetooth Connection & Cable Connection. You just need to connect your phone with cable or bluetooth, and then open the singing APP on your phone. The built-in clear audio and vividly sound effect can make you listening and singing anytime and anywhere. When using TF card, short press to TF CARD mode; short press again, line-in mode.

If you have USB cable connect computer and TF CARD in it, short press to USB mode, short press again, TF CARD mode; short press again, line-in mode.

OPERATING THE KARAOKE WIRELESS MIC/SPEAKER

Playing music wirelessly

Once the Karaoke Wireless Mic/Speaker is paired to your device, you can stream music wirelessly to the built-in speaker. Select the track you wish to listen to on your device to play through the speaker. Should you encounter any problems while streaming, please refer to your device's user manual.

Adjust Voice Echo

Push the echo switch up or down to adjust voice echo.

Adjust Microphone Voice Volume

Push the volume switch up or down to adjust voice volume.

Funny Voice

Long press button: Switch to strange mode 4 sounds.
Short press: Switch to accompaniment mode.

SPECIFICATIONS

Bluetooth® Version:	V5.1 + EDR
Operating Distance:	Up to 33ft (10m)
Pick Up:	Capacitive
Speaker Output:	3W
Speaker Impedance:	4Ω
Frequency Range:	150Hz - 18kHz
Sensitivity:	80db - 115db
Play Time:	Up to 3 hours
Battery Type:	Lithium-ion
Battery Capacity:	1200 mAh
Charging Voltage:	DC 5V
Charging Time:	Up to 5 Hours
Charging Interface:	Micro USB
FCC ID:	2AANZKRK2-
BTID:	D051448

CARE AND MAINTENANCE

- Do not expose the unit to excessive heat or humidity to avoid damage to the product's internal circuitry.
- Do not use abrasive cleaning solvents to clean the unit.
- Do not expose the unit to extremely high or low temperatures as this will shorten the life of the electronic device, destroy the battery, and/or distort certain plastic parts.
- Do not dispose of the unit in fire as they may explode or combust.
- Do not expose the unit to contact with sharp objects as this will cause scratches and damage.
- Do not let the unit fall from high places, as doing so may damage the internal circuitry.
- Do not attempt to disassemble the unit.

FCC STATEMENT

This device complies with part 15 of the FCC Rules. Operation is subject to the following two conditions: (1) This device may not cause harmful interference, and (2) this device must accept any interference received, including interference that may cause undesired operation.

FCC INSTRUCTIONS FOR A CLASS B DIGITAL DEVICE OR PERIPHERAL

Note: This equipment has been tested and found to comply with

the limits for a Class B digital device, pursuant to part 15 of the FCC Rules. These limits are designed to provide reasonable protection against harmful interference in a residential installation. This equipment generates, uses and can radiate radio frequency energy and, if not installed and used in accordance with the instructions, may cause harmful interference to radio communications. However, there is no guarantee that interference will not occur in a particular installation. If this equipment does cause harmful interference to radio or television reception, which can be determined by turning the equipment off and on, the user is encouraged to try to correct the interference by one or more of the following measures:

- Reorient or relocate the receiving antenna.
- Increase the separation between the equipment and receiver.
- Connect the equipment into an outlet on a circuit different from that to which the receiver is connected.
- Consult the dealer or an experienced radio/TV technician for help.
- Changes or modifications not expressly approved by the party responsible for compliance could void the user's authority to operate the equipment.

WARRANTY INFORMATION

The condition of this warranty and our responsibilities under this warranty are as follows:

Supplier's warranty is non-transferable. And this warranty is limited to the original purchaser only.

* You must be able to prove the date of original purchase of the unit with a dated receipt.

* The warranty is not applicable if the product has been subject to physical abuse, improper installation, modification or repair by unauthorized third party.

* The responsibility of supplier's products shall be limited to the repair or replacement of the product as its sole discretion.

* Specifically exempt from any warranty are limited-life consumable components subject to normal wear and tear such as batteries, decorates and other accessories.

* A supplier will not take any responsibility if the failure of the unit has resulted from accident, abuse, misuse, or any unauthorized repair, modification or disassemble.

* Modification and repair of the unit should be done by

authorized and qualified service personnel, Center or returned to the manufacturer.

* This warranty gives you specific legal rights, and you may also have other rights which vary under local laws.

The following conditions comprise the requirements and scope of our warranty conditions and do not affect our legal and contractual warranty obligations. We offer a warranty on our products in accordance with the following conditions:

1) Vibe™ products are covered by a 3 month warranty. We will resolve damages or defects on Vibe™ products free of charge within 3 months of the purchase date under the following warranty conditions. For any damage or defect determined later than 3 months after the purchase date, proof of a manufacturing fault must be submitted for repair under warranty.

2) The warranty does not cover batteries and other parts, which are considered consumables, parts that break easily such as glass or plastic or defects based on normal wear and tear. There is no warranty obligation in the event of marginal differences compared to the target appearance and workmanship provided these have a negligible effect on the product's fitness for use, in the event of damage caused by chemical or electrochemical effects, by water or generally from abnormal conditions.

3) The warranty will be performed in such a way that we shall decide whether to repair the defective parts or to replace them with working parts free of charge. Vibe™ reserves the right to exchange the product for a replacement product of equal value if the product sent in cannot be repaired within a reasonable time or at a reasonable cost. Requests cannot be made for repairs to be carried out on site. Parts that have been replaced or exchanged become our property.

4) The warranty claim does not apply if repairs or other work is carried out by unauthorized persons or if our products are equipped with additional parts or accessories that are not approved for our product.

5) Warranties that have been activated do not cause the warranty period to be extended, nor do they trigger a new warranty period. The warranty period for any replacement parts installed ends with the warranty period for the entire product.

6) Any other further claims are excluded, especially those for replacement due to damage caused to the outside of the product, provided there is no obligatory legal liability.

We therefore accept no liability for accidental, indirect or other consequential damage of any kind, which leads to usage restrictions, data loss, and loss of earnings or interruption to business.

Asserting a warranty claim:

- 1) To make use of the warranty service for hardware issues, you must contact the Vibe™ Service Center by email at support@dgusa.com
- 2) Vibe™ will try to diagnose and solve your problem. If it is determined that a warranty claim exists, you will be given an RMA number (Return Material Authorization) and will be asked to send the product to Vibe™.

IMPORTANT: Vibe™ will only accept parcels that have an RMA number.

Please observe the following when sending the product:
1) Send the product suitably packaged with carriage and insurance paid. Do not enclose any accessories with the product (cables, chargers, manuals, etc.) unless the Vibe™ Service Center specifies otherwise.

2) Mark the RMA number on the outside of the package in such a way that it is visible and clearly legible.

3) You must enclose a copy of the sales slip as proof of purchase.

4) Once Vibe™ has received the product, it will meet its warranty obligations in accordance with the warranty conditions and will return the product to the sender with carriage and insurance paid.

Service outside of warranty
Vibe™ can refuse any service claim made that is not covered by the warranty.

If Vibe™ agrees to provide a service outside the warranty, the customer will be invoiced for all repair and transport costs. Vibe™ will not accept any packages that have not first been approved by Vibe™ by means of an RMA (Return Material Authorization).

Contact us with questions at:
Support@dgusa.com