



HYPE®

DISCO

Operation Manual HY-TIMBRE

FCC ID: 2AANZHY-TIMBRE

BT ID: B020865

Thank you for purchasing the Disco Bluetooth® Speaker. Please read all instructions carefully before using and retain this manual for future use and reference.

PACKAGE CONTENTS

- Disco Bluetooth® Speaker
- USB Charging Cable
- 3.5mm AUX Cable
- Operation Manual

KEY FEATURES

- Creates a kaleidoscope effect
- Lights project while you play your music
- Built-in rechargeable battery
- Media & volume controls

SAFETY INSTRUCTIONS

Keep the unit away from heat sources, direct sunlight, humidity, water and any other liquids.

Do not operate the unit if it has been exposed to water, moisture or any other liquids to prevent against electric shock, explosion and/or injury to yourself and damage to the unit.

Do not use the unit if it has been dropped or damaged in any way.

Repairs to electrical equipment should only be performed by a qualified electrician. Improper repairs may place the user at serious risk.

Do not puncture or harm the exterior surface of the product in any way.

Keep the unit free from dust, lint, etc.

Do not use this unit for anything other than its intended use or purpose. Doing so may damage the device.

This product is not a toy. Keep out of reach of children.

Do not use the speaker at excessive levels as this may damage hearing.

1

Do not expose batteries, battery pack, or batteries to installed to excessive heat, such as direct sunlight, or open flame.

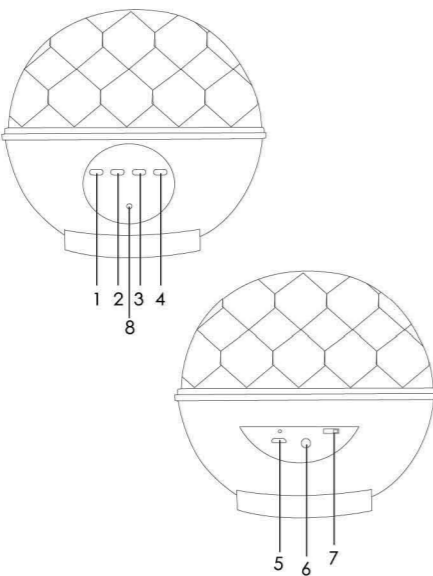

FEATURES/PARTS

1. Call/Play/Pause
2. Previous Song/Volume Decrease
3. Next Song/ Volume Increase
4. LED Mode/LED Power
5. Micro USB Charge Port
6. AUX Input
7. OFF/ON Switch
8. Mic

2

CHARGING THE SPEAKER

The speaker comes with a built-in rechargeable battery. Before using it for the first time, we recommend you charge the battery fully. Only use the supplied USB cable to charge the speaker.

Connect the USB cable to a computer USB port and the Micro USB plug to the charging jack of the Unit. The red LED light will illuminate while the speakers are charging.

A full charge of the battery takes up to 3 hours. When the battery is fully charged the red LED will turn off. Disconnect the speakers at this point. The speakers will then be ready for use.

TURNING SPEAKERS ON/OFF

Power On: Move the power switch into the ON position depending how you are using it.

Power Off: Move the power switch into the OFF position.

PAIRING THE SPEAKERS

1. Ensure the speaker is turned off. If they are not, please turn off the speaker first before pairing.
2. Move the power switch into the ON position and the device will then beep. This will indicate your speaker is now in pairing mode.
3. Place the speaker and the Bluetooth® device to which you would like to pair it within the operating distance. We recommend keeping the two devices no further than 33 feet apart.
4. Once you have activated Bluetooth® on your device, select "HY-TIMBRE" from the list of available Bluetooth® devices.
5. Ensure Bluetooth® is enabled on your phone or music device. Refer to the manufacturer's instructions for how to enable Bluetooth® on your device.

3

7. If pairing is unsuccessful, turn off the speaker first and repair following the aforementioned steps. Once you have paired the speaker with a device, the earphones will remember this device and will pair automatically when the device's Bluetooth® is activated and in range. You do not need to re-pair any previously connected devices.

LISTENING TO MUSIC

Once the speaker is paired to your device, you can stream music wirelessly to the speakers. Select the track you wish to listen to on your device to listen via speaker. Should you encounter any problems while streaming, please refer to your device's user manual.

USING A 3.5MM AUX CABLE

1. Using the included 3.5mm AUX cable, connect one end of the cable into the speakers 3.5mm AUX input.
2. Connect the other end into the 3.5mm input of the device you wish to play music from.
3. Move the power switch into the ON position.
4. In order to use with aux cable, you need to hold down the M button on the front of the speaker to switch to AUX mode firstly.
5. Begin playing music from your connected device, media buttons on speaker may not work in this mode. In AUX Mode, the M button will work after pressing play button on your device.

MANUAL KEY FUNCTIONS

The speaker is equipped with a few shortcut keys. Please note the following functions.

1. Increase Volume - Press hold the "V+ / ►" button
2. Decrease Volume - Press and hold the "◀ / V-" button
3. Play/Pause - Press M / ◻ button
4. Previous Track - Press the "◀ / V-" button
5. Next Track - Press the "V+ / ►" button
6. Answering/Ending a call- press M / ◻ button

SWITCH LED LIGHTS

1. Press the LED to cycle through different LED modes. The LED lights will not react to music in every mode.
2. To turn off the lights press and hold the LED button.
3. To turn the lights back on, press and hold the LED button.

4

CARE AND MAINTENANCE

- Do not expose the speaker to liquid, moisture, or humidity to avoid damage to the product's internal circuitry.
- Do not use abrasive cleaning solvents to clean the unit.
- Do not expose the headset to extremely high or low temperatures as this will shorten the life of the electronic device, destroy the battery, and/or distort certain plastic parts.
- Do not dispose of the speaker in fire as they may explode or combust.
- Do not expose the speaker to contact with sharp objects as this will cause scratches and damage.
- Do not let the speaker fall from high places, as doing so may damage the internal circuitry.
- Do not attempt to disassemble the speaker

In the event that the speaker do not function properly, return it to the store where it was purchased.

SPECIFICATIONS

Bluetooth®:	V2.1
Sensitivity:	75dB
Frequency:	180Hz-20kHz
Operating Distance:	Up to 33ft (10m)
Play Time:	Up to 1.5 Hours
Speaker Power:	3W x 2
Battery:	Built-in Rechargeable 3.7V, 800mAh
Charging Time:	Up to 3 Hours

5

WARRANTY INFORMATION

The condition of this warranty and our responsibilities under this warranty are as follows:

Supplier's warranty is non-transferable. And this warranty is limited to the original purchaser only.

- * You must be able to prove the date of original purchase of the unit with a dated receipt.
- * The warranty is not applicable if the product has been subject to physical abuse, improper installation, modification or repair by unauthorized third party.
- * The responsibility of supplier's products shall be limited to the repair or replacement of the product as its sole discretion.
- * Specifically exempt from any warranty are limited-life consumable components subject to normal wear and tear such as batteries, decorates and other accessories.
- * A supplier will not take any responsibility if the failure of the unit has resulted from accident, abuse, misuse, or any unauthorized repair, modification or disassemble.
- * Modification and repair of the unit should be done by authorized and qualified service personnel. Center or returned to the manufacturer.
- * This warranty gives you specific legal rights, and you may also have other rights which vary under local laws.

The following conditions comprise the requirements and scope of our warranty conditions and do not affect our legal and contractual warranty obligations. We offer a warranty on our products in accordance with the following conditions:

- 1) Hype® products are covered by a 12 month warranty. We will resolve damages or defects on Hype® products free of charge within 12 months of the purchase date under the following warranty conditions. For any damage or defect determined later than 12 months after the purchase date, proof of a manufacturing fault must be submitted for repair under warranty.
- 2) The warranty does not cover batteries and other parts, which are considered consumables, parts that break easily such as glass or plastic or defects based on normal wear and tear. There is no warranty

6

obligation in the event of marginal differences compared to the target appearance and workmanship provided these have a negligible effect on the product's fitness for use, in the event of damage caused by chemical or electrochemical effects, by water or generally from abnormal conditions.

- 3) The warranty will be performed in such a way that we shall decide whether to repair the defective parts or to replace them with working parts free of charge. Hype® reserves the right to exchange the product for a replacement product of equal value if the product sent in cannot be repaired within a reasonable time or at a reasonable cost. Requests cannot be made for repairs to be carried out on site. Parts that have been replaced or exchanged become our property.
- 4) The warranty claim does not apply if repairs or other work is carried out by unauthorized persons or if our products are equipped with additional parts or accessories that are not approved for our product.
- 5) Warranties that have been activated do not cause the warranty period to be extended, nor do they trigger a new warranty period. The warranty period for any replacement parts installed ends with the warranty period for the entire product.
- 6) Any other further claims are excluded, especially those for replacement due to damage caused to the outside of the product, provided there is no obligatory legal liability.

We therefore accept no liability for accidental, indirect or other consequential damage of any kind, which leads to usage restrictions, data loss, and loss of earnings or interruption to business.

Asserting a warranty claim:

- 1) To make use of the warranty service for hardware issues, you must contact the Hype® Service Center by email at support@dgusa.com
- 2) Hype® will try to diagnose and solve your problem. If it is determined that a warranty claim exists, you will be given an RMA number (Return Material Authorization) and will be asked to send the product to Hype®.

IMPORTANT: Hype® will only accept parcels that have an RMA number.

7

Please observe the following when sending the product:

- 1) Send the product suitably packaged with carriage and insurance paid. Do not enclose any accessories with the product (cables, chargers, manuals, etc.) unless the Hype® Service Center specifies otherwise.
- 2) Mark the RMA number on the outside of the package in such a way that it is visible and clearly legible.
- 3) You must enclose a copy of the sales slip as proof of purchase.
- 4) Once Hype® has received the product, it will meet its warranty obligations in accordance with the warranty conditions and will return the product to the sender with carriage and insurance paid.

Service outside of warranty
Hype® can refuse any service claim made that is not covered by the warranty.

If Hype® agrees to provide a service outside the warranty, the customer will be invoiced for all repair and transport costs. Hype® will not accept any packages that have not first been approved by Hype® by means of an RMA (Return Material Authorization). Contact us with questions at: support@dgusa.com

8

This equipment has been tested and found to comply with the limits for a Class B digital device, pursuant to part 15 of FCC Rules. These limits are designed to provide reasonable protection against harmful interference in a residential installation. This equipment generates and can radiate radio frequency energy and, if not installed and used in accordance with the instructions, may cause harmful interference to radio communications. However, there is no guarantee that interference will not occur in a particular installation. If this equipment does cause harmful interference to radio or television reception, which can be determined by turning the equipment off and on, the user is encouraged to try to correct the interference by one or more of the following measures:

- Reorient or relocate the receiving antenna.
 - Increase the separation between the equipment and receiver.
 - Connect the equipment into an outlet on a circuit different from that to which the receiver is connected.
 - Consult the dealer or an experienced radio/TV technician for help.
- This device complies with Part 15 of FCC Rules. Operation is subject to the following two conditions: (1) This device may not cause harmful interference, and (2) This device must accept any interference received, including interference that may cause undesired operation.

9

Note: The manufacturer is not responsible for any radio or TV interference caused by unauthorized modifications to this equipment. Such modifications could void the user's authority to operate this equipment. Any Changes or modifications not expressly approved by the party responsible for compliance could void the user's authority to operate the equipment.

This device is measured RF output power is less than the SAR exclusion threshold value for human head and body. Therefore, SAR test is not necessary.

10