

Always there to help you

Register your product and get support at www.philips.com/welcome

Question?
Contact
Philips

SPA4270BT



- EN User manual
- ES Manual del usuario
- FR Mode d'emploi

PHILIPS

P&F USA Inc.
PO Box 2248
Alpharetta, GA 30023-2248
Phone 1 866 309 0845

Meet Philips at the Internet
<http://www.philips.com/welcome>



2014 © WOOX Innovations Limited.
All rights reserved.

This product was brought to the market by WOOX Innovations Limited or one of its affiliates, further referred to in this document as WOOX Innovations, and is the manufacturer of the product. P&F is the warrantor in relation to the product with which this booklet was packaged. Philips and the Philips Shield Emblem are registered trademarks of Koninklijke Philips N.V.

SPA4270BT_37_UM_V1.0



EN

1 Important

Safety



This bolt of lightning indicates uninsulated material within your unit may cause an electrical shock. For the safety of everyone in your household, please do not remove product covering.

The exclamation point calls attention to features for which you should read the enclosed literature closely to prevent operating and maintenance problems.

Warning

- To reduce the risk of fire or electric shock, this apparatus should not be exposed to rain or moisture and objects filled with liquids, such as vases, should not be placed on this apparatus.
- To completely disconnect the power input, the mains plug of the product shall be disconnected from the mains.
- The mains plug of the product should not be obstructed OR should be easily accessed during intended use.
- No naked flame sources, such as lighted candles, shall be placed on the products.

Important Safety Instructions

- Read these instructions.
- Keep these instructions.
- Heed all warnings.
- Follow all instructions.
- Do not use this apparatus near water.
- Clean only with dry cloth.
- Do not block any ventilation openings. Install in accordance with the manufacturer's instructions.
- Do not install near any heat sources such as radiators, heat registers, stoves, or other apparatus (including amplifiers) that produce heat.
- Do not defeat the safety purpose of the polarized or grounding-type plug. A polarized plug has two blades with one wider than the other. A grounding type plug has two blades and a third grounding prong. The wide blade or the third prong are provided for your safety. If the provided plug does not fit into your outlet, consult an electrician for replacement of the obsolete outlet.

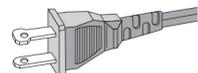

AC Polarized Plug

- Protect the power cord from being walked on or pinched, particularly at plugs, convenience receptacles, and the point where they exit from the apparatus.
- Only use attachments/accessories specified by the manufacturer.
- Unplug this apparatus during lightning storms or when unused for long periods of time.
- Refer all servicing to qualified service personnel. Servicing is required when the apparatus has been damaged in any way, such as power-supply cord or plug is damaged, liquid has been spilled or objects have fallen into the apparatus, the apparatus has been exposed to rain or moisture, does not operate normally, or has been dropped.
- Apparatus shall not be exposed to dripping or splashing.
- Do not place any sources of danger on the apparatus (e.g. liquid filled objects, lighted candles).
- Where the MAINS plug or an appliance coupler is used as the disconnect device, the disconnect device shall remain readily operable.

Warning

- Never remove the casing of this unit.
- Never lubricate any part of this unit.
- Place this unit on a flat, hard and stable surface.
- Never place this unit on other electrical equipment.
- Keep this unit away from water, moisture and liquid-filled objects.
- Keep this unit away from direct sunlight, naked flames or heat.

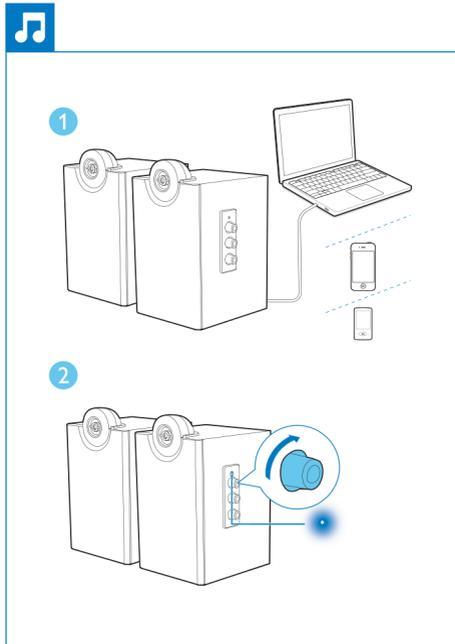
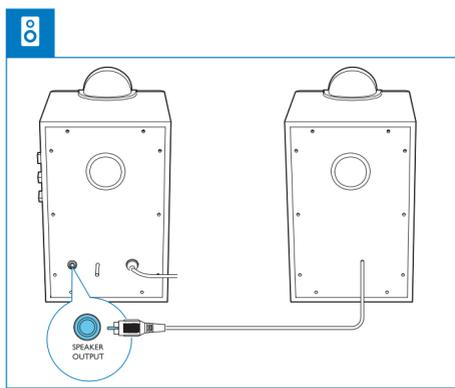
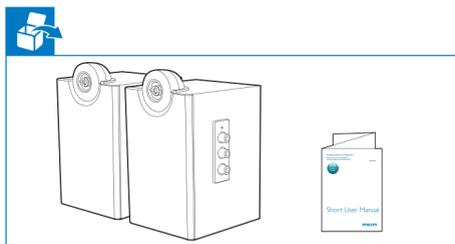

Notice for the USA

This equipment has been tested and found to comply with the limits for a Class B digital device, pursuant to part 15 of the FCC Rules. These limits are designed to provide reasonable protection against harmful interference in a residential installation. This equipment generates, uses, and can radiate radio frequency energy and, if not installed and used in accordance with the instruction manual, may cause harmful interference to radio communications.

However, there is no guarantee that interference will not occur in a particular installation. If this equipment does cause harmful interference to radio or television reception, which can be determined by turning the equipment off and on, the user is encouraged to try to correct the interference by one or more of the following measures:

- Relocate the receiving antenna.
 - Increase the separation between equipment and receiver.
 - Connect the equipment into an outlet on a circuit different from that to which the receiver is connected.
 - Consult the dealer or an experienced radio/TV technician for help.
- This device complies with Part 15 of the FCC Rules. Operation is subject to the following two conditions:
- This device may not cause harmful interference, and
 - This device must accept any interference received, including interference that may cause undesired operation.

This equipment complies with FCC's and IC's RF radiation exposure limits set forth for an uncontrolled environment. The antenna(s) used for this transmitter must be installed and operated to provide a separation distance of at least 20 cm from all persons and must not be collocated or operating in conjunction with any other antenna or transmitter. Installers must ensure that 20cm separation distance will be maintained between the device (excluding its handset) and users.

Notice for Canada

This device complies with Industry Canada licence-exempt RSS standard(s). Operation is subject to the following two conditions: (1) this device may not cause interference, and (2) this device must accept any interference, including interference that may cause undesired operation of the device.

CAN ICES(B)/NMB-3(B)

Notice

Any changes or modifications made to this device that are not expressly approved by WOOX Innovations may void the user's authority to operate the equipment.

Disposal of your old product and batteries

Your product is designed and manufactured with high quality materials and components, which can be recycled and reused. Never dispose of your product with other household waste. Please inform yourself about the local rules on the separate collection of electrical and electronic products and batteries. The correct disposal of these products helps prevent potential negative consequences on the environment and human health. Your product contains batteries, which cannot be disposed of with normal household waste. Please inform yourself about the local rules on separate collection of batteries. The correct disposal of batteries helps prevent potentially negative consequences on the environment and human health. Please visit www.recycle.philips.com for additional information on a recycling center in your area.

Environmental information

All unnecessary packaging has been omitted. We have tried to make the packaging easy to separate into three materials: cardboard (box), polystyrene foam (buffer) and polyethylene (bags, protective foam sheet). Your system consists of materials which can be recycled and reused if disassembled by a specialized company. Please observe the local regulations regarding the disposal of packaging materials, exhausted batteries and old equipment.

Note

- The type plate is located on the back panel of the right speaker.

2 Your multimedia speaker

Congratulations on your purchase and welcome to Philips!
To fully benefit from the support that Philips offers, register your product at www.philips.com/welcome.

Get started

Caution

- Use of controls or adjustments or performance of procedures other than herein may result in hazardous radiation exposure or other unsafe operation.

Always follow the instructions in this chapter in sequence.

Installation

- Insert the RCA cable from the left speaker to the SPEAKER OUT socket on the right speaker.
- Connect the AC plug to AC power socket.

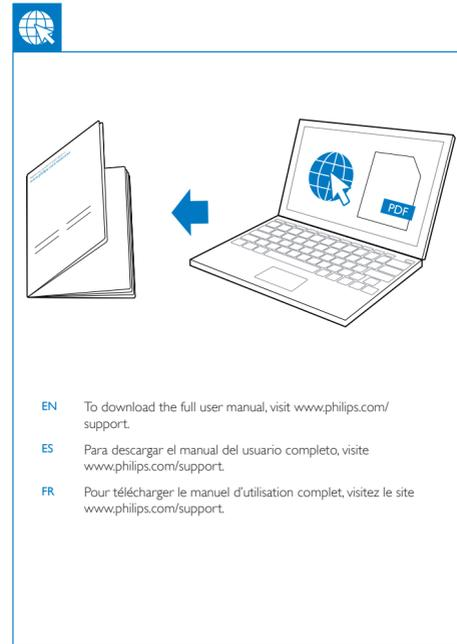
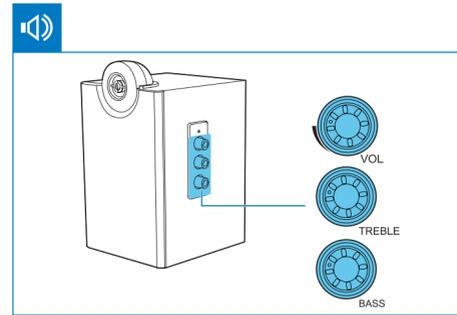
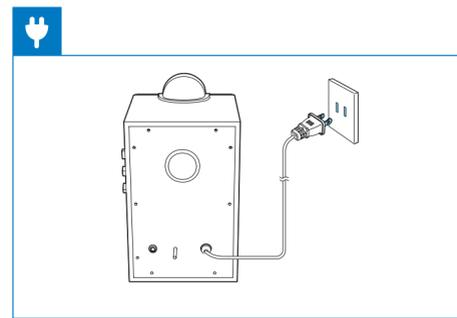

Note

- To download the full user manual, visit www.philips.com/support.
- Para descargar el manual del usuario completo, visite www.philips.com/support.
- Pour télécharger le manuel d'utilisation complet, visitez le site www.philips.com/support.

3 Play

Play through Bluetooth

The multimedia speaker uses Bluetooth wireless technology to stream music from your portable device to the system.

Note

- Your Bluetooth device should be with Bluetooth software of version 2.1 or above.
- Before you connect a Bluetooth device to this multimedia speaker, familiarize yourself with the Bluetooth capabilities of the device.
- Keep this multimedia speaker away from other electronic devices that may cause interference.
- Make sure that the multimedia speaker is installed properly before using.

- On the side panel of the right speaker, rotate the VOL knob clockwise.
↳ Bluetooth will be activated automatically.
↳ The LED indicator on the multimedia speaker blinks.
↳ To switch off the speaker, rotate the VOL knob counter-clockwise, until you hear one click.
- On your Bluetooth device, activate Bluetooth and search for Philips SPA4270BT.
↳ For the first-time connection, select Philips SPA4270BT to start pairing.
↳ For some devices, you may need to input "0000" as pairing password.
↳ If connection is successful, you will hear double beep confirmation.
↳ The LED indicator lights in blue.
- Play audio with the media player of your device.
↳ The audio comes out through the multimedia speaker.
↳ Next time you switch on Philips SPA4270BT, the speaker connects to the last paired device automatically.
↳ To connect Philips SPA4270BT to another Bluetooth device, switch off Bluetooth on current Bluetooth device.

Tip

- The effective operation range between the multimedia speaker and the paired device is approximately 10 meters (30 feet).
- Any obstacle between the speaker and the device can reduce the operational range.

Play through the audio cable

Note

- Make sure that the multimedia speaker is installed properly before using.

You can also play music from an external audio device, such as a computer, mobile phone, MP3 player, etc.

- Connect the 3.5mm audio in cable (fixed to the AUX-IN socket on the right speaker) to the headphone socket on the external device.
↳ SPA4270BT exits Bluetooth pairing mode when the audio cable is connected to an external audio device.
- On the side panel of the right speaker, rotate the VOL knob clockwise.
↳ The LED indicator on the multimedia speaker turns on stably.
- Play music from the device.
↳ After use, rotate the VOL knob counter-clockwise to switch off the multimedia speaker and unplug.

Control Play

- To increase or decrease volume,
- When the multimedia speaker is turned on, rotate the VOL knob on the side panel of the right speaker to adjust the volume.
- To adjust bass or treble level,
- Rotate the BASS knob on the back panel of the right speaker to adjust the bass.
 - Rotate the TREBLE knob on the back panel of the right speaker to adjust the treble.

4 Product information

AC power	
Input	120V~, 60Hz 486mA
Operation power consumption	15W
Standby power consumption	<1.5W
Dimensions (W x H x D)	143 x 220 x 150 mm

System Requirements:

PC	Mac
Windows® 98SE, Windows® ME, Windows® 2000, Windows® XP, or Windows® Vista™, Windows 7	Mac OS9/OS® X, or later

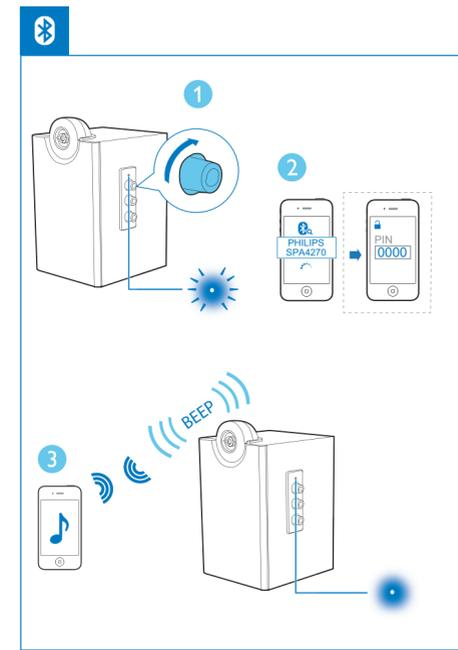

5 Troubleshooting

To keep the warranty valid, never try to repair the system yourself. If you encounter problems when using the product, check the following points before requesting service. If the problem remains unsolved, register your product and get support at www.philips.com/support.

- Make sure that the speakers are correctly installed.
- Make sure the LED lights up.

Register online at www.philips.com/welcome today to get the very most from your purchase.

Registering your model with PHILIPS makes you eligible for all of the valuable benefits listed below so don't miss out. Register online at www.philips.com/welcome to ensure.

*Product Safety Notification

By registering your product, you'll receive notification - directly from the manufacturer:

*Additional Benefits

Registering your product guarantees that you'll receive all of the privileges to which you're entitled, including special money-saving offers.

PHILIPS

Congratulations on your purchase, and welcome to the "family!"

Dear PHILIPS product owner:

Thank you for your confidence in PHILIPS. You've selected one of the best-built, best-backed products available today. We'll do everything in our power to keep you happy with your purchase for many years to come.

As a member of the PHILIPS "family," you're entitled to protection by one of the most comprehensive warranties in the industry. What's more, your purchase guarantees you'll receive all the information and special offers for which you qualify plus easy access to accessories from our convenient home shopping network. Most importantly, you can count on our uncompromising commitment to your total satisfaction.

All of this is our way of saying welcome - and thanks for investing in a PHILIPS product.

Know these safety symbols



This bolt of lightning indicates uninsulated material within your unit may cause an electrical shock. For the safety of everyone in your household, please do not remove product covering.

The exclamation point calls attention to features for which you should read the enclosed literature closely to prevent operating and maintenance problems.

WARNING: To reduce the risk of fire or electric shock, this apparatus should not be exposed to rain or moisture and objects filled with liquids, such as vases, should not be placed on this apparatus.

CAUTION: To prevent electric shock, match wide blade of plug to wide slot, fully insert.

ATTENTION: Pour éviter les choc électriques, introduire la lame la plus large de la fiche dans la borne correspondante de la prise et pousser jusqu'au fond.

P.S. To get the most from your PHILIPS purchase, be sure to register online at:

www.philips.com/welcome

For Customer Use

Enter below the Serial No. which is located on the rear of the cabinet. Retain this information for future reference.
Model No. _____
Serial No. _____

PHILIPS Visit our World Wide Web Site at <http://www.philips.com/welcome>

PHILIPS LIMITED WARRANTY ONE (1) YEAR

WARRANTY COVERAGE:

Philips warranty obligation is limited to the terms set forth below.

WHO IS COVERED:

Philips warrants the product to the original purchaser or the person receiving the product as a gift against defects in materials and workmanship as based on the date of original purchase ("Warranty Period") from an Authorized Dealer. The original sales receipt showing the product name and the purchase date from an authorized retailer is considered such proof.

WHAT IS COVERED:

The Philips warranty covers new products if a defect in material or workmanship occurs and a valid claim is received by Philips within the Warranty Period. At its option, Philips will either (1) repair the product at no charge, using new or refurbished replacement parts, or (2) exchange the product with a product that is new or which has been manufactured from new, or serviceable used parts and is at least functionally equivalent or most comparable to the original product in Philips current inventory, or (3) refund the original purchase price of the product.

Philips warrants replacement products or parts provided under warranty against defects in materials and workmanship from the date of the replacement or repair for ninety (90) days or for the remaining portion of the original product's warranty, whichever provides longer coverage for you. When a product or part is exchanged, any replacement item becomes your property and the replaced item becomes Philips' property. When a refund is given, your product becomes Philips' property.

Note: Any product sold and identified as refurbished or replacement carries a ninety (90) day limited warranty.

Repaired product can only be sent if all warranty requirements are met. Failure to follow all requirements can result in delay.

WHAT IS NOT COVERED - EXCLUSIONS AND LIMITATIONS:

This Limited Warranty applies only to the new products manufactured by or for Philips that can be identified by the trademark, trade name, or logo affixed to it. This Limited Warranty does not apply to any non-Philips hardware product or any software, even if packaged or sold with the product. Non-Philips manufacturers, suppliers, or publishers may provide a separate warranty for their own products packaged with the bundled product.

Philips is not liable for any damage to or loss of any program, data, or other information stored on any media contained within the product, or any non-Philips product or part not covered by warranty. Recovery or reinstatement of programs, data or other information is not covered under this Limited Warranty.

This warranty does not apply (a) to damage caused by accident, abuse, misuse, neglect, misapplication, or non-Philips product, (b) to damage caused by service performed by anyone other than Philips or Philips Authorized Service Location, (c) to a product or a part that has been modified without the written permission of Philips.

This warranty gives you specific legal rights. You may have other rights which vary from state/province to state/province.

P&F USA, Inc., PO Box 2248, Alpharetta, GA 30023-2248

3140 033 51091

ES

1 Importante

Seguridad

Atención a estos símbolos de seguridad



El símbolo del rayo indica que los componentes sin aislamiento dentro de la unidad pueden generar una descarga eléctrica. Para la seguridad de todas las personas de su hogar, no quite la cubierta del producto. El signo de exclamación indica características importantes cuya información debe leer en los manuales adjuntos a fin de evitar problemas en el funcionamiento y en el mantenimiento.

Advertencia

- Para reducir el riesgo de incendio o descarga eléctrica, el aparato no debe exponerse a la lluvia ni a la humedad ni se deben colocar sobre éste objetos que contengan líquidos.
- Para desconectar por completo la entrada de alimentación, el conector de alimentación del dispositivo debe estar desconectado de la toma de corriente.
- Asegúrese de que la toma de alimentación no esté obstruida y que se pueda acceder a ella con facilidad mientras se esté utilizando.
- No coloque sobre el producto llamas sin protección, como velas encendidas.

