



198 Kezhu Road, Scientech Park, Guangzhou Economic & Technological
Development District, Guangzhou, China 510663
Telephone: +86 (0) 20 82155555
Fax: +86 (0) 20 82075059
Email: ee.guangzhou@sgs.com

Report No.: GZEM130300092101
Page: 1 of 79
IC: 3784A-CPLA40A

TEST REPORT

Application No.:	GZEM1303000921RF
Applicant:	Corning Mobile Access Inc.
IC:	3784A-CPLA40A
Product Name:	GX High Power DAS Remote Unit
Model No.:	GX-C85P19L70A17-40,GX-C85P19L70A17-40-DC ♣
♣	Please refer to section 7.3 of this report for details
Trade Mark:	GX
Standards:	RSS-131 Issue 3: July 2003; RSS-Gen Issue 3: December 2010
Date of Receipt:	2013-03-13 and 2014-02-20
Date of Test:	2013-03-13 to 2014-02-14
Date of Issue:	2014-02-17
Test Result :	Pass*

* In the configuration tested, the EUT detailed in this report complied with the standards specified above. Please refer to section 3 of this report for further details.

Richard Li
Manager

The manufacturer should ensure that all products in series production are in conformity with the product sample detailed in this report. If the product in this report is used in any configuration other than that detailed in the report, the manufacturer must ensure the new system complies with all relevant standards.



The report must not be used by the client to claim product certification, approval, or endorsement by NVLAP, NIST, or any agency of the federal government. All test results in this report can be traceable to National or International Standards.

This document is issued by the Company subject to its General Conditions of Service printed overleaf, available on request or accessible at www.sgs.com/terms_and_conditions.htm and, for electronic format documents, subject to Terms and Conditions for Electronic Documents at www.sgs.com/terms_e-document.htm. Attention is drawn to the limitation of liability, indemnification and jurisdiction issues defined therein. Any holder of this document is advised that information contained hereon reflects the Company's findings at the time of its intervention only and within the limits of Client's instructions, if any. The Company's sole responsibility is to its Client and this document does not exonerate parties to a transaction from exercising all their rights and obligations under the transaction documents. This document cannot be reproduced except in full, without prior written approval of the Company. Any unauthorized alteration, forgery or falsification of the content or appearance of this document is unlawful and offenders may be prosecuted to the fullest extent of the law. Unless otherwise stated the results shown in this test report refer only to the sample(s) tested and such sample(s) are retained for 90 days only.

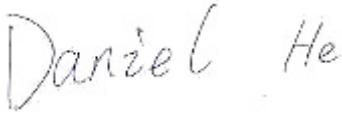
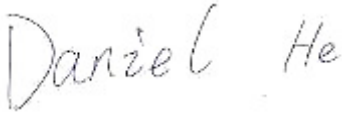

2 Version

Revision Record				
Version	Chapter	Date	Modifier	Remark
00		2014-02-17		Original

Authorized for issue by:			
Tested By			2013-03-13 to 2014-02-14 Date
Prepared By			2014-02-17 Date
Checked By			2014-02-17 Date



3 Test Summary

Test Item	Test Requirement	Test Method	Result
Amplifier Gain and Bandwidth	RSS-131 clause 6.1	RSS-131 clause 4.2	PASS
Output Power	RSS-131 clause 6.2	RSS-131 clause 4.3.1	PASS
Non-Linearity	RSS-131 clause 6.3.1	RSS-131 clause 4.3.1	PASS
Conducted Spurious Emissions	RSS-131 clause 6.4	RSS-131 clause 4.4.1	PASS
Radiated Spurious Emissions	RSS-131 clause 6.4	RSS-Gen clause 4.9	PASS
Frequency Stability of Band Translators	RSS-131 clause 6.5	RSS-131 clause 4.5	PASS
Remark: Tx: In this whole report Tx (or tx) means Transmitter. Rx: In this whole report Rx (or rx) means Receiver.			
No need to implement uplink test as it is cable connect to BTS (No air radiation), then the test about Uplink would be ignored.			
Model No.: GX-C85P19L70A17-40,GX-C85P19L70A17-40-DC According to the confirmation from the applicant, the only difference between above two models is the power supply unit(PSU). GX-C85P19L70A17-40 is with 100-240VAC power supply, while GX-C85P19L70A17-40-DC is with -48VDC power supply. The electrical circuit design, RF modules and optical module used for above models are all identical, the output power and other RF specifications are the same. According to the above differences , the GX-C85P19L70A17-40 was performed full tests and the new model GX-C85P19L70A17-40-DC was tested the Radiated Spurious Emissions and Frequency Stability of Band Translators test in this report.			



4 Contents

	Page
1 COVER PAGE.....	1
2 VERSION.....	2
3 TEST SUMMARY.....	3
4 CONTENTS.....	4
5 GENERAL INFORMATION.....	5
5.1 CLIENT INFORMATION.....	5
5.2 GENERAL DESCRIPTION OF E.U.T.....	5
5.3 DETAILS OF E.U.T.....	5
5.4 PRODUCT DESCRIPTION.....	6
5.5 STANDARDS APPLICABLE FOR TESTING.....	6
5.6 TEST LOCATION.....	6
5.7 OTHER INFORMATION REQUESTED BY THE CUSTOMER.....	6
5.8 TEST FACILITY.....	7
6 EQUIPMENT USED DURING TEST.....	8
7 TEST RESULTS.....	10
7.1 E.U.T. TEST CONDITIONS.....	10
7.2 TEST PROCEDURE & MEASUREMENT DATA.....	11
7.2.1 Amplifier Gain and Bandwidth.....	13
7.2.2 Output Power.....	19
7.2.3 Non-Linearity.....	22
7.2.4 Conducted Spurious Emissions.....	49
7.2.5 Radiated Spurious Emissions.....	70
7.2.6 Frequency Stability of Band Translators.....	76



5 General Information

5.1 Client Information

Applicant Name: Corning Mobile Access Inc.
Applicant Address: 8391 Old Courthouse Road, Suite 300 Vienna Virginia 22182 United States
Manufacturer: Comba Telecom Technology (Guangzhou) Ltd.
Address of Manufacturer: No.6 Jinbi Road, Economics and Technology Development District, Guangzhou Guangdong China

5.2 General Description of E.U.T.

Product Name: GX High Power DAS Remote Unit
Model No.: GX-C85P19L70A17-40, GX-C85P19L70A17-40-DC
Power Supply: AC 100-240V 50/60Hz or DC -48V
Test power: AC 120V 60Hz and DC -48V
Operating Temperature: -40 °C to +70°C
Operating Humidity: ≤ 95%

5.3 Details of E.U.T.

Type of Modulation CDMA & WCDMA & GSM & LTE
GXW(GSM)
Emission Designator: F9W(CDMA),
F9W (WCDMA)
G7D(LTE)
Frequency Band: Downlink 728MHz to 756MHz include the Modulation:LTE
Downlink 869MHz to 894MHz include the Modulation:
GSM, CDMA, WCDMA, LTE
Downlink 1930MHz to 1995MHz include the Modulation:
GSM, CDMA, WCDMA, LTE
Downlink 2110MHz to 2155MHz include the Modulation:
CDMA, WCDMA, LTE
Nominal Power Output: 46dBm for downlink
Nominal System Gain: 68dB for downlink



5.4 Product Description

MobileAccessGX offers a scalable, cost-effective 20/40W (43/46dBm) high power remote outdoor coverage solution for Corning MobileAccess Distributed Antenna Systems (DAS). It is a fiber-fed, compact, multi-service, multi-operator remote designed to complement the MobileAccess1000 and MobileAccess2000 lower power, standard remotes or installable as a dedicated deployment solution in a new site, providing complete RF coverage options for open indoor, tunnel and adjacent outdoor spaces in larger venues such as stadiums, convention centers, metro-rails and malls.

5.5 Standards Applicable for Testing

RSS-131 Issue 3: July 2003; RSS-Gen Issue 3: December 2010

5.6 Test Location

All tests were performed at:

SGS-CSTC Standards Technical Services Co., Ltd., Guangzhou EMC Laboratory,
198 Kezhu Road, Scientech Park, Guangzhou Economic & Technology Development District,
Guangzhou, China 510663

Tel: +86 20 82155555 Fax: +86 20 82075059

No tests were sub-contracted.

5.7 Other Information Requested by the Customer

None.

5.8 Test Facility

The test facility is recognized, certified, or accredited by the following organizations:

- **NVLAP (Lab Code: 200611-0)**

SGS-CSTC Standards Technical Services Co., Ltd., Guangzhou EMC Laboratory is recognized under the National Voluntary Laboratory Accreditation Program (NVLAP/NIST). NVLAP Code: 200611-0.

- **ACMA**

SGS-CSTC Standards Technical Services Co., Ltd., EMC Laboratory can also perform testing for the Australian C-Tick mark as a result of our NVLAP accreditation.

- **SGS UK(Certificate No.: 32), SGS-TUV SAARLAND and SGS-FIMKO**

Have approved SGS-CSTC Standards Technical Services Co., Ltd., EMC Laboratory as a supplier of EMC TESTING SERVICES and SAFETY TESTING SERVICES.

- **CNAS (Lab Code: L0167)**

SGS-CSTC Standards Technical Services Co., Ltd., EMC Laboratory has been assessed and in compliance with CNAS-CL01:2006 accreditation criteria for testing laboratories (identical to ISO/IEC 17025:2005 General Requirements) for the Competence of Testing Laboratories.

- **FCC (Registration No.: 282399)**

SGS-CSTC Standards Technical Services Co., Ltd., EMC Laboratory has been registered and fully described in a report filed with the (FCC) Federal Communications Commission. The acceptance letter from the FCC is maintained in our files. Registration 282399, May 31, 2002.

- **Industry Canada (Registration No.: 4620B-1)**

The 3m/10m Alternate Semi-anechoic chamber of SGS-CSTC Standards Technical Services Co., Ltd. has been registered by Certification and Engineering of Industry Canada for radio equipment testing with Registration No. 4620B-1.

- **VCCI (Registration No.: R-2460, C-2584, G-449 and T-1179)**

The 10m Semi-anechoic chamber and Shielded Room of SGS-CSTC Standards Technical Services Co., Ltd. have been registered in accordance with the Regulations for Voluntary Control Measures with Registration No.: R-2460, C-2584, G-449 and T-1179 respectively.

- **CBTL (Lab Code: TL129)**

SGS-CSTC Standards Technical Services Co., Ltd., E&E Laboratory has been assessed and fully comply with the requirements of ISO/IEC 17025:2005, the Basic Rules, IEC 60335-1:2006-10 and Rules of procedure IEC 60335-2:2006-10, and the relevant IEC 60335-2:2006-10 Operational documents.



6 Equipment Used during Test

RE in Chamber						
No.	Test Equipment	Manufacturer	Model No.	Serial No.	Cal.Due date	Calibration Interval
					(YYYY-MM-DD)	
EMC0525	Compact Semi-Anechoic Chamber	ChangZhou ZhongYu	N/A	N/A	2014-08-30	2Y
EMC0522	EMI Test Receiver	Rohde & Schwarz	ESIB26	100283	2014-05-06	1Y
EMC0056	EMI Test Receiver	Rohde & Schwarz	ESCI	100236	2014-03-04	1Y
EMC0528	RI High frequency Cable	SGS	20 m	N/A	2014-05-09	1Y
EMC2025	Trilog Broadband Antenna 30-3000MHz	SCHWARZBECK MESS-ELEKTRONIK	VULB 9163	9163-450	2016-08-31	3Y
EMC0524	Bi-log Type Antenna	Schaffner -Chase	CBL6112B	2966	2016-08-31	3Y
EMC0519	Bilog Type Antenna	Schaffner -Chase	CBL6143	5070	2014-06-02	2Y
EMC2026	Horn Antenna 1-18GHz	SCHWARZBECK MESS-ELEKTRONIK	BBHA 9120D	9120D-841	2016-08-31	3Y
EMC0518	Horn Antenna	Rohde & Schwarz	HF906	100096	2014-07-01	2Y
EMC0521	1-26.5 GHz Pre-Amplifier	Agilent	8449B	3008A01649	2014-03-04	1Y
EMC2065	Amplifier	HP	8447F	N/A	2014-08-31	1Y
EMC2063	1-26GHz Pre Amplifier	Compliance Direction System Inc.	PAP-1G26-48	6279.628	2014-07-29	1Y
EMC0075	310N Amplifier	Sonama	310N	272683	2014-03-04	1Y
EMC0523	Active Loop Antenna	EMCO	6502	42963	2014-04-07	2Y
EMC2041	Broad-Band Horn Antenna (14)15-26.5(40)GHz	SCHWARZBECK MESS-ELEKTRONIK	BBHA 9170	9170-375	2014-06-01	3Y
EMC2069	2.4GHz filter	Micro-Tronics	BRM 50702	149	2014-06-05	1Y
EMC0530	10m Semi-Anechoic Chamber	ETS	N/A	N/A	2014-04-27	2Y
EMC2041	Broad-Band Horn Antenna(14)15-26.5(40)GHz	SCHWARZBECK MESS-ELEKTRONIK	BBHA 9170	9170-375	2014/6/11	3Y



SGS-CSTC Standards Technical Services Co., Ltd.

Report No.: GZEM130300092101

Page: 9 of 79

IC: 3784A-CPLA40A

Other equipment						
No:	Test Equipment	Manufacturer	Model No.	Serial No.	Cal. Date (dd-mm-yy)	Cal. Due Date (dd-mm-yy)
NA	Power Meter	Agilent	E4419B	MY45100856	2012.6.12	2014.6.11
NA	Signal Generator	Agilent	E4437B	US39260800	2012.6.17	2014.6.16
NA	Signal Generator	Agilent	E4438C	US39260800	2012.6.14	2014.6.14
NA	Spectrum Analyzer	Agilent	N9020A	MY48011385	2012.6.14	2014.6.14
NA	Spectrum Analyzer	Rohde&Schwarz	FSQ 8	SN0805772	2012.6.14	2014.6.14
NA	Attenuator	SHX manufacturer	30dB/50W	09031816	----	----
NA	Attenuator	SHX manufacturer	40dB/50W	09031312	----	----
NA	Attenuator	SHX manufacturer	50dB/50W	09053023	----	----
NA	Signal Generator	Rohde&Schwarz	SMU 200A	08103303	2012.6.12	2014.6.11

General used equipment						
No.	Test Equipment	Manufacturer	Model No.	Serial No.	Cal.Due date	Calibration Interval
					(YYYY-MM-DD)	
EMC0006	DMM	Fluke	73	70681569	2014-09-13	1Y
EMC0007	DMM	Fluke	73	70671122	2014-09-13	1Y



7 Test Results

7.1 E.U.T. test conditions

Input Voltage: AC 120V and DC -48V

Operating Environment:

Temperature: 22°C ~26°C

Humidity: 46%~56% RH

Atmospheric Pressure: 990~1005mbar

Test Requirement: The RF output power of the EUT was measured at the antenna port, by adjusting the input power of signal generator to drive the EUT to get to maximum output power point and keep the EUT at maximum gain setting for all tests. The device should be tested on downlink.

For detail test Modulation and Frequency, please refer to 7.2.

Remark:

The GX system working principle: the RF signal coupled from BTS is transferred into optical signal, and then transmitted via a fiber to remote unit. The remote re-transfers the optical signal back to RF signal, through the frequency translation and after power amplifiers, can extend the BTS coverage to another desired area, the GX system is compliant with the description about band translators (Repeater) in RSS-131 rules.



7.2 Test Procedure & Measurement Data

Test Modulation and Frequency

Downlink: 728MHz to 756MHz

Modulation	Lowest frequency	Middle frequency	Highest frequency
LTE	733	742	751

Downlink: 869MHz to 894MHz

Modulation	Lowest frequency	Middle frequency	Highest frequency
GSM	869.6	881.5	893.4
CDMA	871	881.5	892
WCDMA	872	881.5	891
LTE	874	881.5	889

Downlink: 1930MHz to 1995MHz

Modulation	Lowest frequency	Middle frequency	Highest frequency
GSM	1930.6	1962.5	1994.4
CDMA	1932	1962.5	1993
WCDMA	1933	1962.5	1992
LTE	1935	1962.5	1990

Downlink: 2110 MHz to 2155MHz

Modulation	Lowest frequency	Middle frequency	Highest frequency
CDMA	2112	2132.5	2153
WCDMA	2113	2132.5	2152
LTE	2115	2132.5	2150

Remark:

- 1) We test the downlink in the lowest band; the middle band; the highest band and test the respective frequency as above table;

General Test Setup:

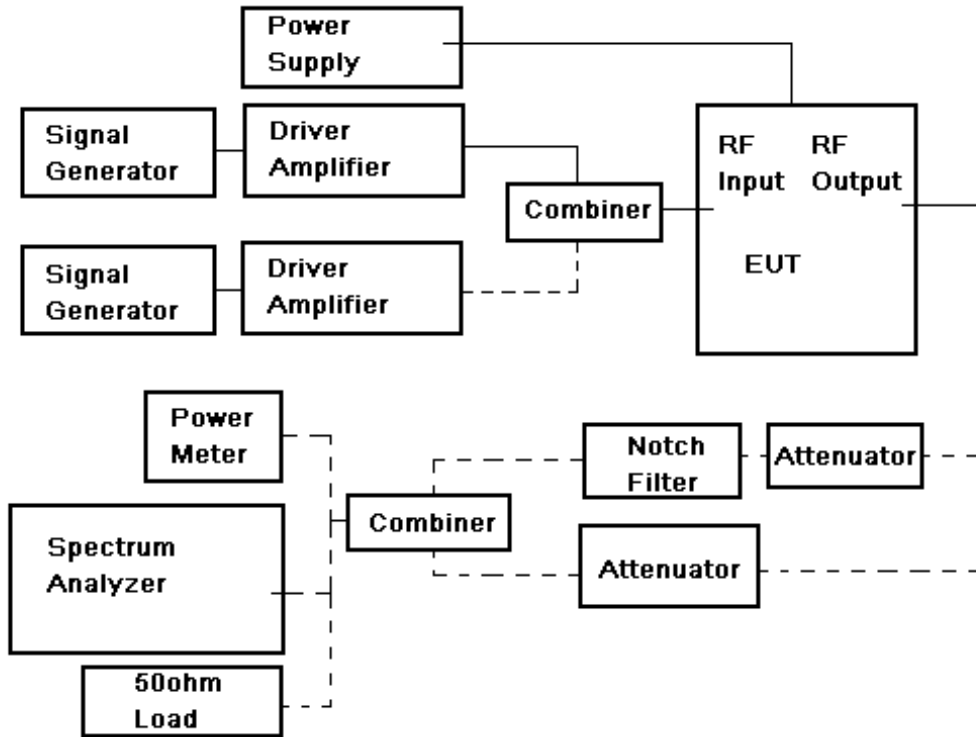

7.2.1 Amplifier Gain and Bandwidth

Test Requirement: RSS-131 clause 6.1

Test Limit The passband gain shall not exceed the nominal gain by more than 1.0 dB. The 20 dB bandwidth shall not exceed the nominal bandwidth that is stated by the manufacturer. Outside of the 20 dB bandwidth, the gain shall not exceed the gain at the 20 dB point.

Test Method: RSS-131 clause 4.2

EUT Operation:

Status: Drive the EUT to maximum output power.

Conditions: Normal conditions

Application: RF output ports

Test Configuration:

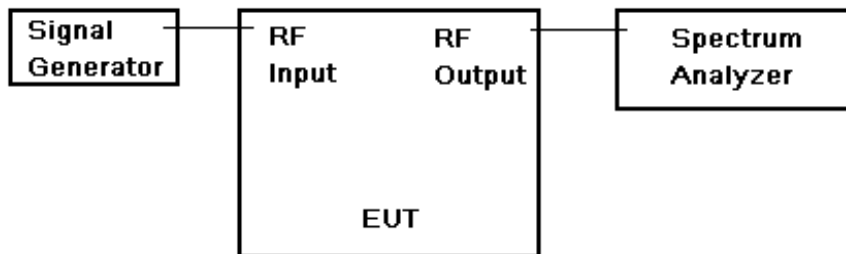



Test Procedure:

- 1) Connect the equipment as illustrated, when the output power is over the max value of the Spectrum Analyzer, add the attenuator to avoid destroying the facility.
- 2) Set the center frequency of the spectrum analyzer to the assigned transmitter frequency, key the transmitter, and set the level of the carrier to the full scale reference line.
- 3) Adjust the internal gain control of the equipment under test to the nominal gain for which equipment certification is sought.
- 4) With the aid of a signal generator and spectrum analyser, measure the 20 dB bandwidth of the amplifier (i.e. at the point where the gain has fallen by 20 dB). Measure the gain-versus-frequency response of the amplifier from the midband frequency f_0 of the pass band up to at least $f_0 \pm 250\%$ of the 20 dB bandwidth.

7.2.1.1 Measurement Record:

1) Downlink: 728MHz to 756MHz

Test items	Test result	Test limit	Pass/Fail
Passband gain	67.25dB	± 1dB	Pass
20dB Bandwidth	30.24	?MHz	Pass

Remark:
 Input Power = -21dBm for downlink
 Nominal System Gain: 68dB
 Nominal Bandwidth is: ?MHz

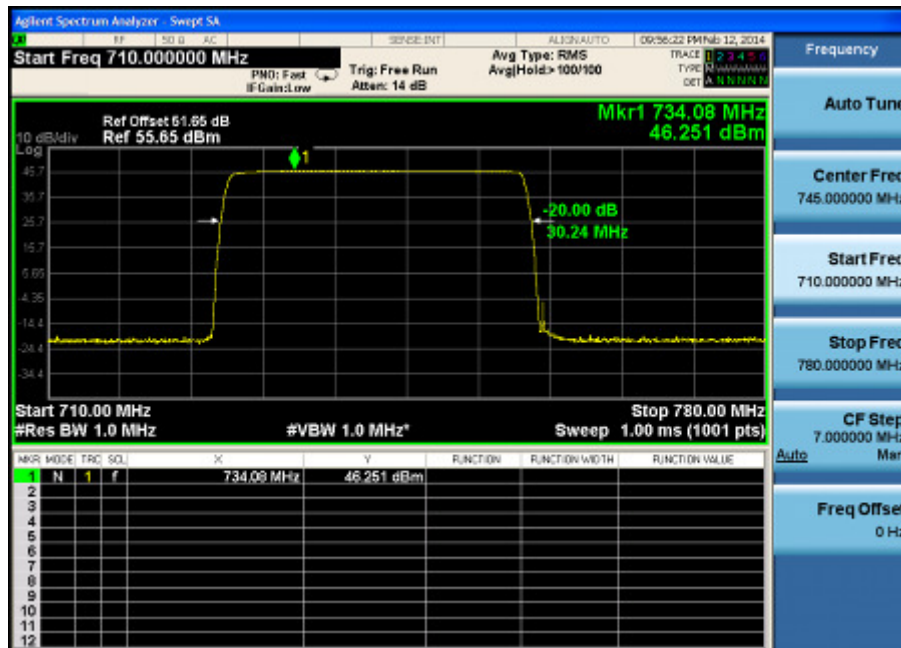



2) Downlink: 869MHz to 894MHz

Test items	Test result	Test limit	Pass/Fail
Passband gain	67.56dB	± 1dB	Pass
20dB Bandwidth	33.27	36MHz	Pass

Remark:

Input Power = -21dBm for downlink

Nominal System Gain: 68dB

Nominal Bandwidth is: 36MHz

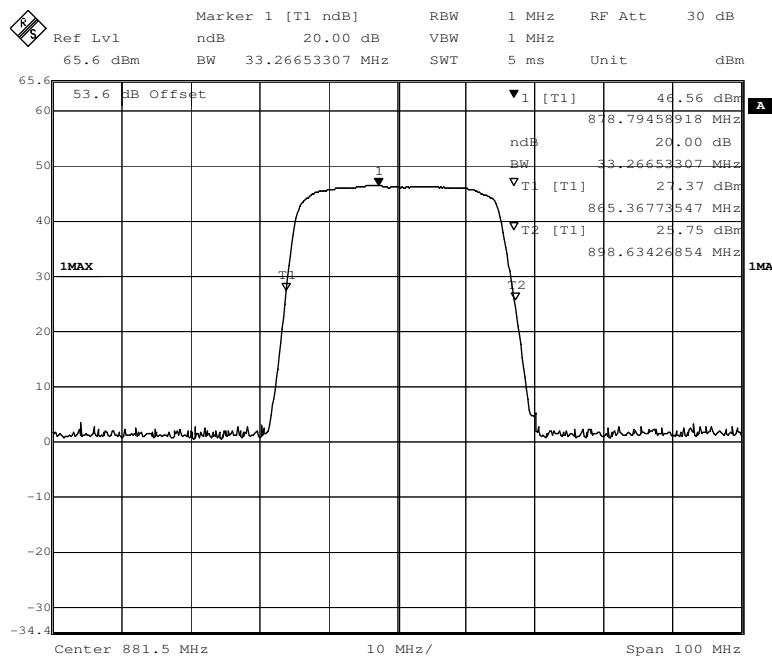



3) Downlink: 1930MHz to 1995MHz

Test items	Test result	Test limit	Pass/Fail
Passband gain	67.03dB	± 1dB	Pass
20dB Bandwidth	77.35	82MHz	Pass

Remark:

Input Power = -21dBm for downlink

Nominal System Gain: 68dB

Nominal Bandwidth is: 82MHz

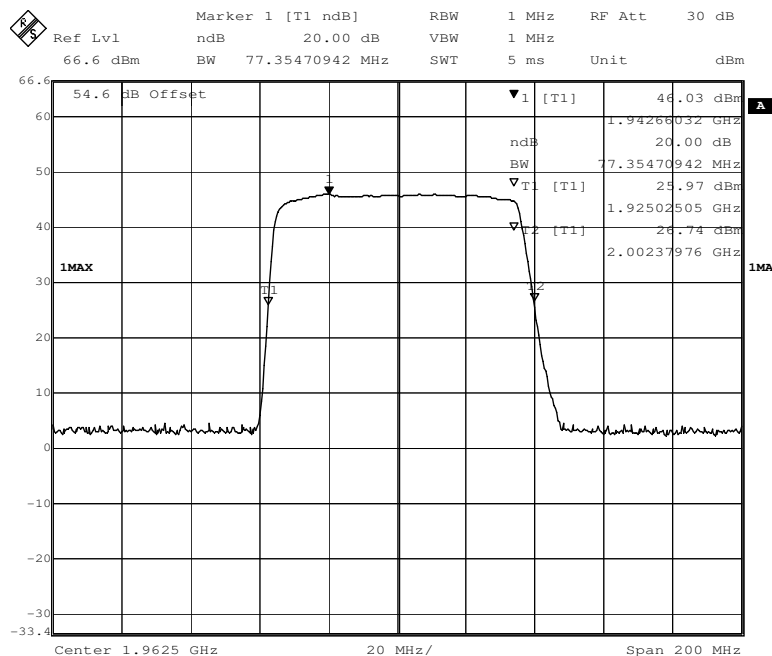



4) Downlink: 2110MHz to 2155MHz

Test items	Test result	Test limit	Pass/Fail
Passband gain	67.72dB	± 1dB	Pass
20dB Bandwidth	63.73	70MHz	Pass

Remark:

Input Power =-21dBm for downlink

Nominal System Gain: 68dB

Nominal Bandwidth is: 70MHz

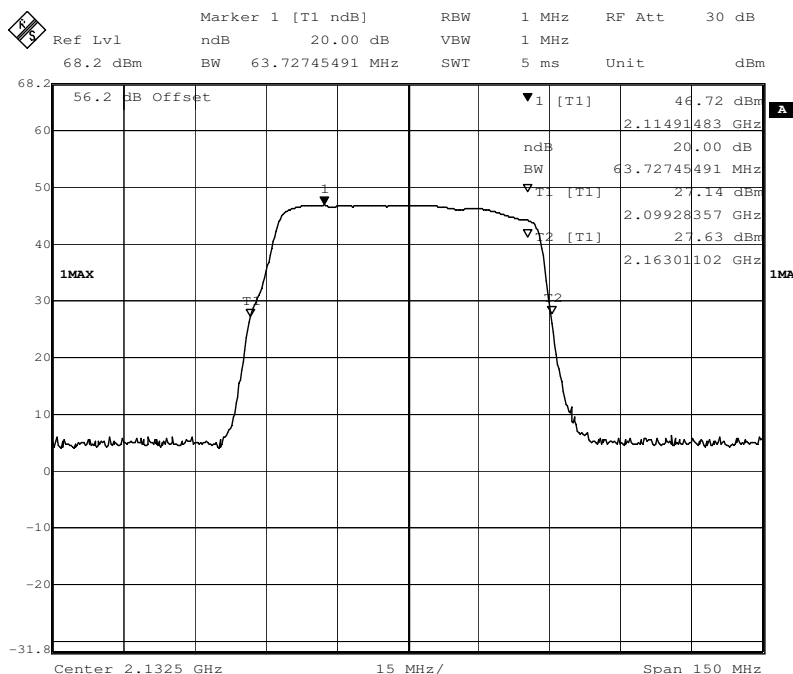

7.2.2 Output Power

Test Requirement:	RSS-131 clause 6.2
Test Limit	The manufacturer's output power rating P rated MUST NOT be greater than P mean for all types of enhancers.
Test Method:	RSS-131 clause 4.3.1
EUT Operation:	
Status:	Drive the EUT to maximum output power.
Conditions:	Normal conditions
Application:	RF output ports
Test Configuration:	

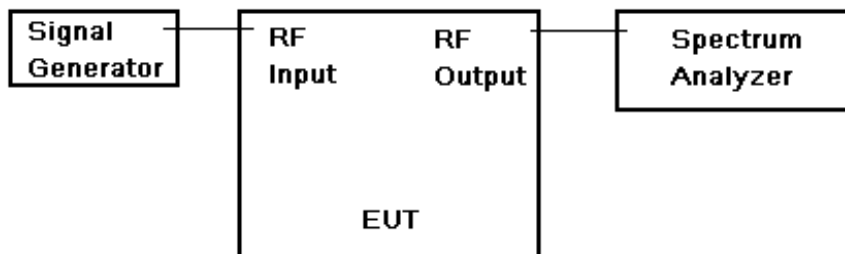

Test Procedure:	<p>RF output power test procedure:</p> <ol style="list-style-type: none"> 1. <ol style="list-style-type: none"> a) Connect the equipment as illustrated, when the output power is over the max value of the Spectrum Analyzer, add the attenuator to avoid destroying the facility. b) Set the center frequency of the spectrum analyzer to the assigned transmitter frequency, key the transmitter, and set the level of the carrier to the full scale reference line. c) do not apply any tone to modulate the EUT. d1) Adjust the spectrum analyzer for the following settings: <ol style="list-style-type: none"> 1) Resolution Bandwidth >> the carrier bandwidth, 2) Video Bandwidth refer to standard requirement. d2) Use spectrum analyzer channel power measurement function; e) Record the frequencies and levels of carrier power; f) Calculate the signal link way loss and final power value. Or 2. <ol style="list-style-type: none"> a) Connect the equipment as illustrated; b) Read the value from the power meter; c) Calculate the signal link way loss and final power value.
-----------------	---



7.2.2.1 Measurement Record:

Downlink: 728MHz ~ 757MHz

Per channel Power Input=-20dBm for downlink			
Modulation	Lowest frequency	Middle frequency	Highest frequency
LTE	46.3dBm (42657.9519mW)	46.4dBm (43651.5832mW)	46.2dBm (41686.9383mW)

Downlink: 869MHz ~ 894MHz

Per channel Power Input=-20dBm for downlink			
Nominal Power Output= 46dBm			
Modulation	Lowest frequency	Middle frequency	Highest frequency
GSM	46.1dBm (40738.0277mW)	46.5dBm (44668.3592mW)	46.4dBm (43651.5832mW)
CDMA	46.2dBm (41686.9383mW)	46.4dBm (43651.5832mW)	46.5dBm (44668.3592mW)
WCDMA	46.3dBm (42657.9519mW)	46.2dBm (41686.9383mW)	46.5dBm (44668.3592mW)
LTE	46.3dBm (42657.9519mW)	46.2dBm (41686.9383mW)	46.4dBm (43651.5832mW)

Downlink: 1930MHz ~ 1995MHz

Per channel Power Input=-20dBm for downlink			
Nominal Power Output= 46dBm			
Modulation	Lowest frequency	Middle frequency	Highest frequency
GSM	46.4dBm (43651.5832mW)	46.3dBm (42657.9519mW)	46.5dBm (44668.3592mW)
CDMA	46.2dBm (41686.9383mW)	46.3dBm (42657.9519mW)	46.5dBm (44668.3592mW)
WCDMA	46.6dBm (45708.8189mW)	46.3dBm (42657.9519mW)	46.1dBm (40738.0277mW)
LTE	46.2dBm (41686.9383mW)	46.4dBm (43651.5832mW)	46.5dBm (44668.3592mW)



Downlink: 2110MHz ~ 2155MHz

Per channel Power Input=-20dBm for downlink Nominal Power Output= 46dBm			
Modulation	Lowest frequency	Middle frequency	Highest frequency
CDMA	46.4dBm (43651.5832mW)	46.3dBm (42657.9519mW)	46.1dBm (40738.0277mW)
WCDMA	46.2dBm (41686.9383mW)	46.3dBm (42657.9519mW)	46.4dBm (43651.5832mW)
LTE	46.3dBm (42657.9519mW)	46.2dBm (41686.9383mW)	46.1dBm (40738.0277mW)

7.2.3 Non-Linearity

Test Requirement: RSS-131 clause 6.3
 Test Limit Transmitter signals amplified by a non-linear device (enhancer or translator) will alter the occupied bandwidth of the transmitted signals; therefore, the extent of non-linearity shall be tested.

clause 6.3.1:

For a multi-channel enhancer, any intermodulation product level must be attenuated, relative to P, by at least:

$43 + 10 \text{ Log } 10 P$, or 70 dB, whichever is less stringent.

(-13dBm is the less stringent value)

where P is the total RF output power of the test tones in watts.

Test Method: RSS-131 clause 4.3.1

EUT Operation:

Status: Drive the EUT to maximum output power.

Conditions: Normal conditions

Application: RF output ports

Test Configuration:

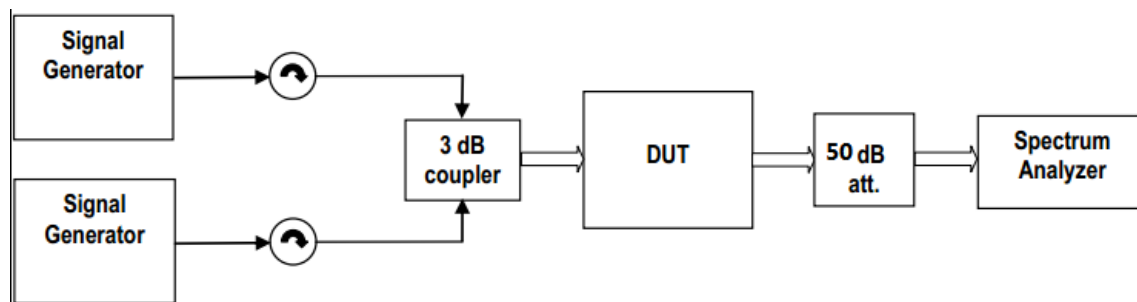

- Test Procedure:
1. Connect the equipment as illustrated;
 2. Test the background noise level with all the test facilities;
 3. Keep one transmitting path, all other connectors shall be connected by normal power or RF leads;
 4. The following subscript "o" denotes a parameter at the enhancer output point.
 5. Connect two signal generators to the input of the Device Under Test (DUT), via a proper impedance matching network (and preferably via a variable attenuator) so that the two input signals are equal sinusoids (and can be raised equally).
 6. Connect a dummy load of suitable load rating to the enhancer output point. Connect also a spectrum analyser to this output point via a coupling network and attenuator, so that only a portion of the output signal is coupled to the spectrum analyser. The coupling attenuation shall be stated in the test report.
 7. Set the two generator frequencies f_1 and f_2 such that they and their third-order intermodulation product frequencies, $f_3 = 2f_1 - f_2$ and $f_4 = 2f_2 - f_1$, are all within the pass band of the DUT.
 8. Raise the input level to the DUT while observing the output tone levels, P_{o1} and P_{o2} , and the intermodulation product levels, P_{o3} and P_{o4} .



Remark:

- At maximum drive level, for each modulation: one test with three tones, or two tests (high-, low-band edge) with two tones
- Limit usually is -13dBm conducted.
- Not needed for Single Channel systems.



7.2.3.1 Measurement Record:

1. Downlink: 728MHz to 756MHz(LTE Mode)

1.1 two signal input —Lower Edge

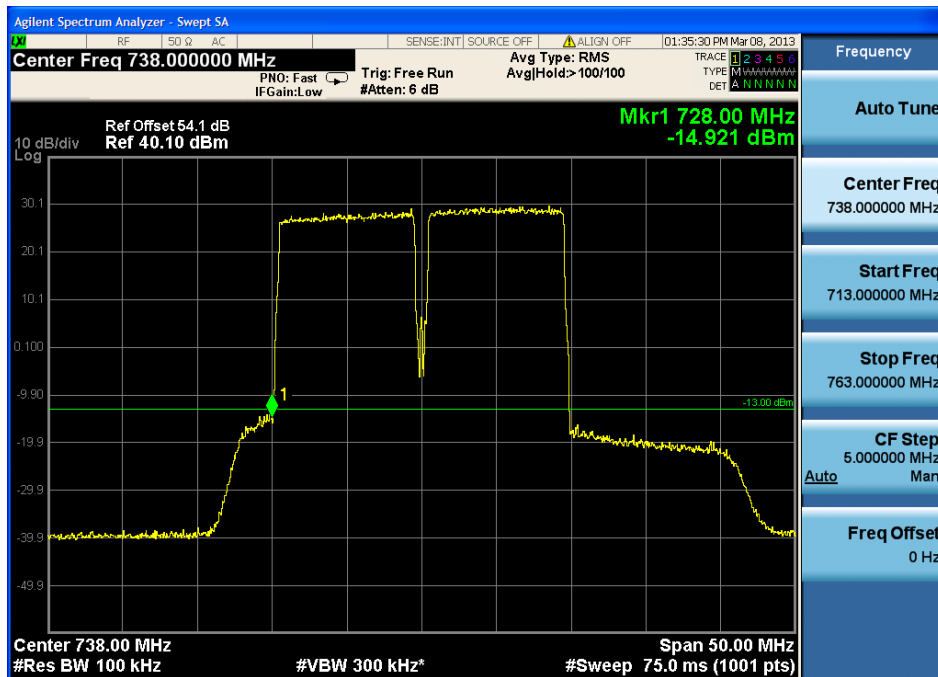

1.2 two signal input —Upper Edge

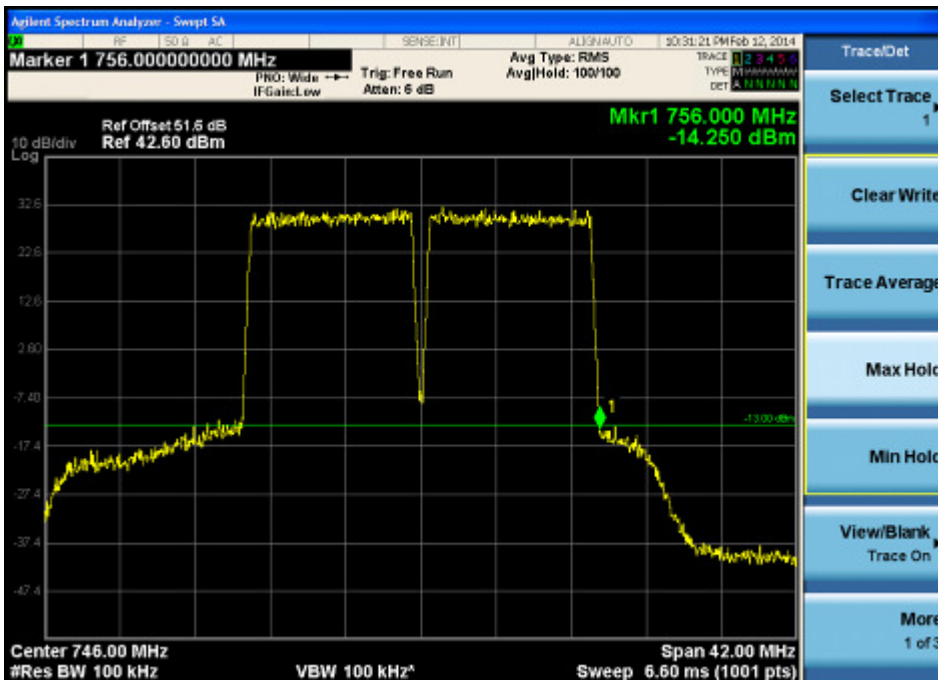



1.3 intermodulation spurious emissions

1.3.1 Input frequency:

1)in lower edge test:f1 is the lower edge frequency +1 channel frequency, and f2 is +2 channel frequency

f1=733MHz,f2=743MHz

2)in higher edge test:f1 is the higher edge frequency -2 channel frequency, and f2 is -1 channel frequency

f1=741MHz,f2=751MHz

base the 3rd product frequency F1= 2f1-f2 and F2=2f2-f1, when the f1 and f2 frequency select above,

- a) in lower edge test, F1=2f1-(f1+Δf)=f1-Δf=lower edge frequency;
b) in higher edge test, F2=2f2-(f2-Δf)=f2+Δf=higher edge frequency.

F1=728MHz,F2=756MHz

base the 5th product frequency F1= 3f1-2f2 and F2=3f2-2f1, when the f1 and f2 frequency select above,

- a) in lower edge test, F1=3f1-2(f1+Δf)=f1-2Δf=lower edge frequency;
b) in higher edge test, F2=3f2-2(f2-Δf)=f2+2Δf=higher edge frequency.

F1=718MHz,F2=766MHz

base the 7th product frequency F1= 4f1-3f2 and F2=4f2-3f1, when the f1 and f2 frequency select above,

- a) in lower edge test, F1=4f1-3(f1+Δf)=f1-3Δf=lower edge frequency;
b) in higher edge test, F2=4f2-3(f2-Δf)=f2+3Δf=higher edge frequency.

F1=708MHz,F2=776MHz

1.3.2 Input power:-20dBm

Table with 4 columns: measure frequency, product Value (dBm), Limit (dBm), and Margin (dB). It contains data for 3rd, 5th, and 7th order intermodulation products at lower and higher edge tests.

Remark:

No other intermodulation spurious emissions of above 7th have been found,so only record the test data about the 3rd, 5th and 7th



2. Downlink: 869MHz to 894MHz(GSM,CDMA,WCDMA,LTE)

2.1 GSM Mode:

2.1.1 two signal input —Lower Edge

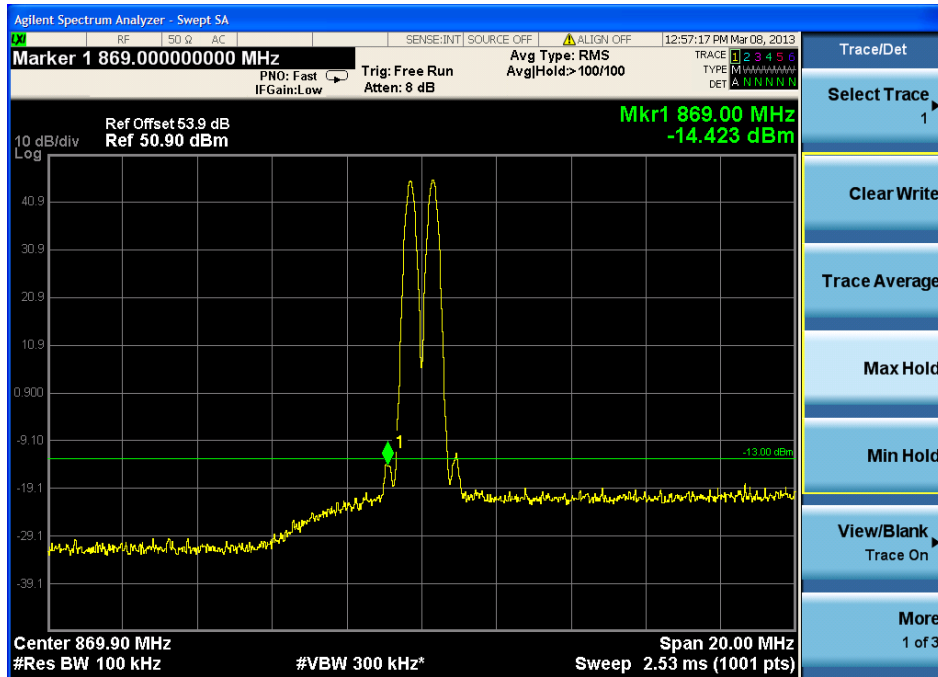

2.1.2 two signal input —Upper Edge

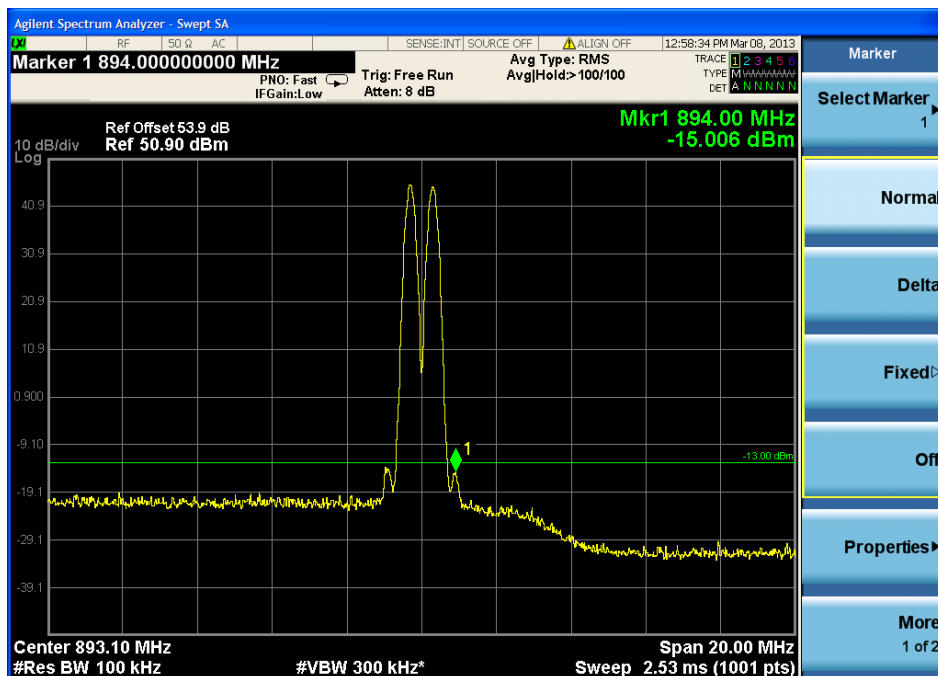



2.2 CDMA Mode:

2.2.1 two signal input —Lower Edge

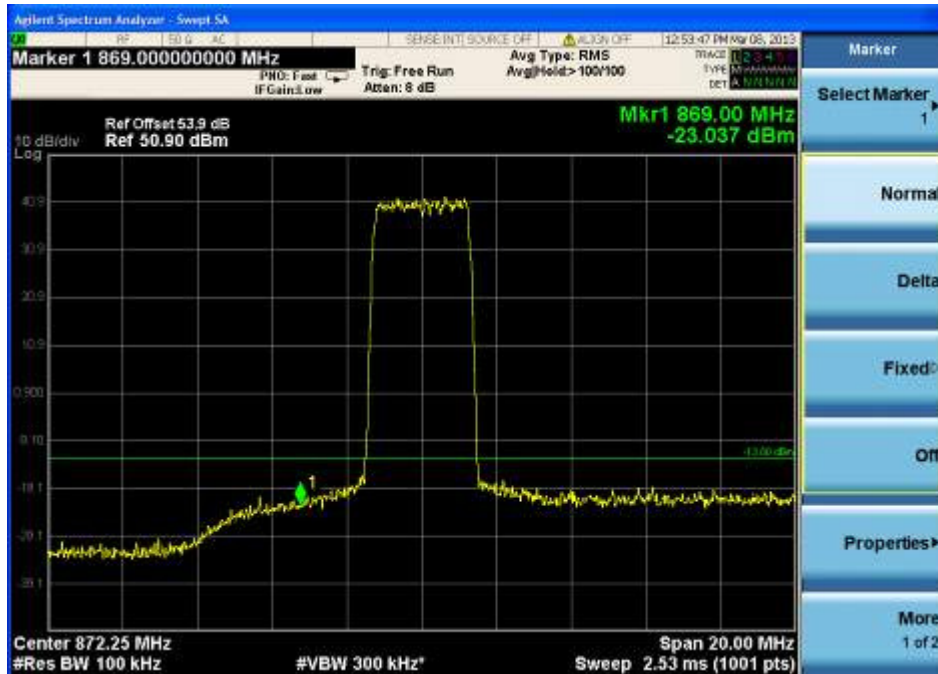

2.2.2 two signal input —Upper Edge

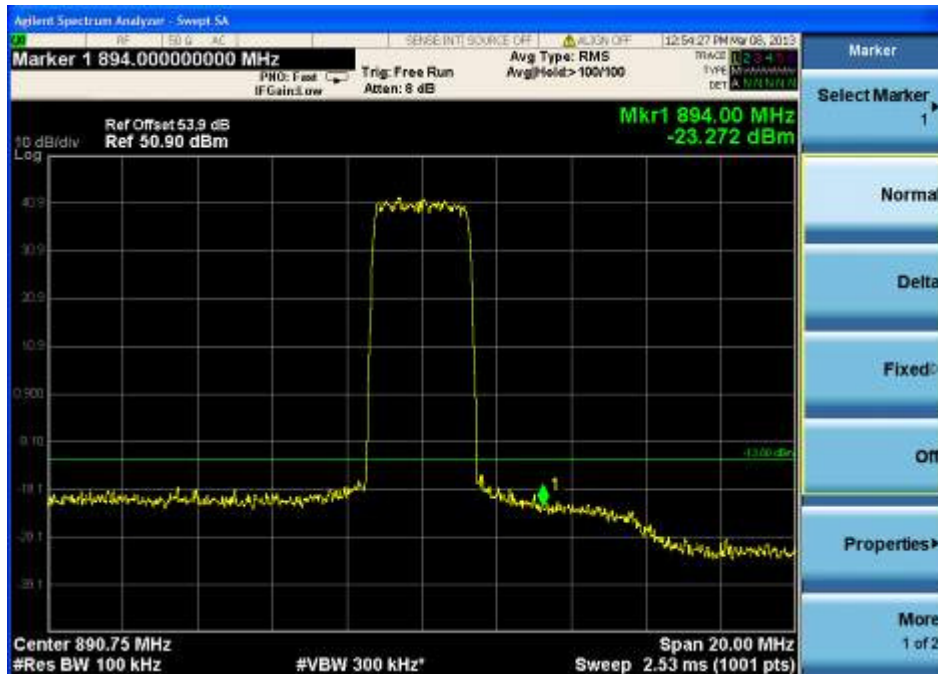

2.3 WDMA Mode:

2.3.1 two signal input —Lower Edge

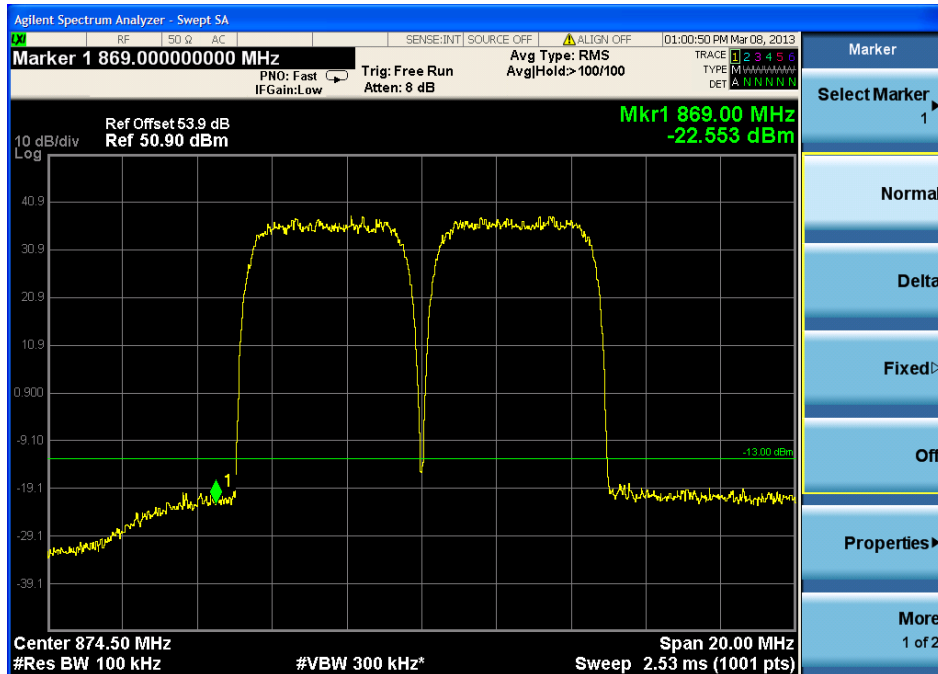

2.3.2 two signal input —Upper Edge





2.4 LTE Mode:

2.4.1 two signal input —Lower Edge

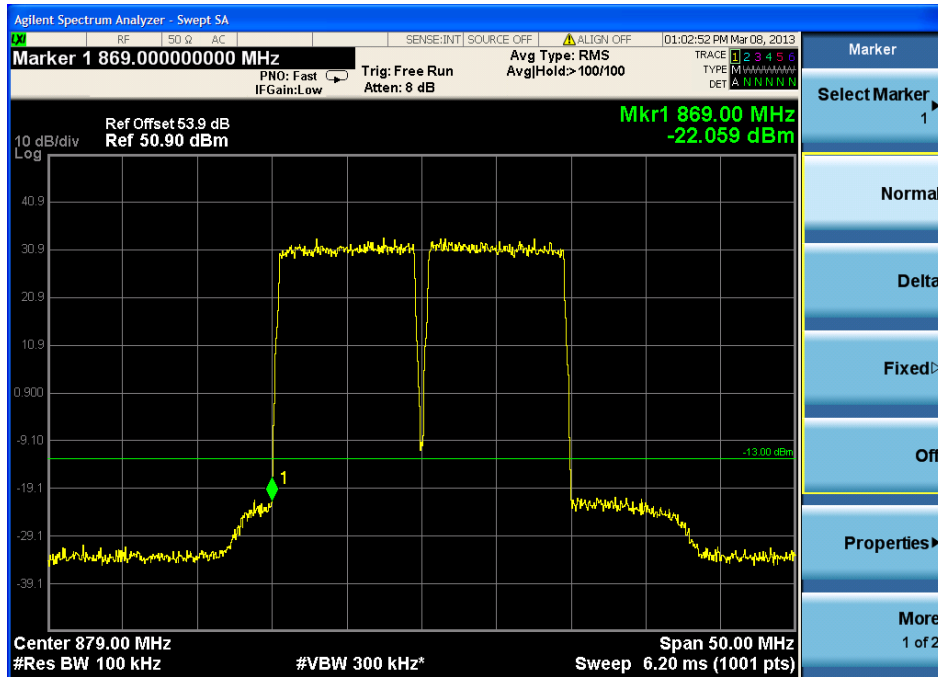

2.4.2 two signal input —Upper Edge

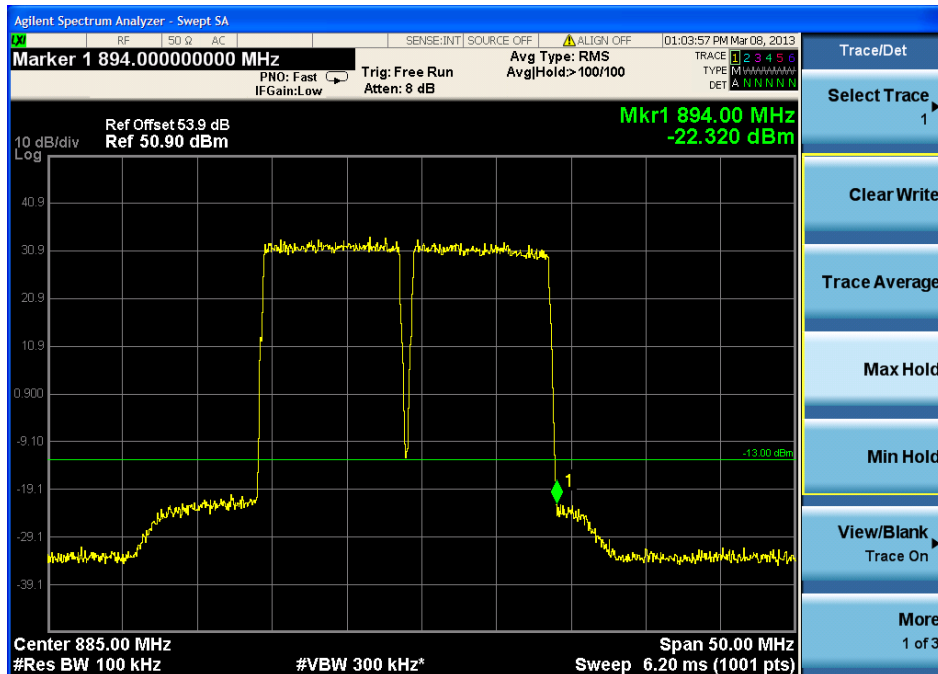



2.5 intermodulation spurious emissions

2.5.1 For GSM mode:

Input frequency:

1)in lower edge test:f1 is the lower edge frequency +1 channel frequency, and f2 is +2 channel frequency

f1=869.6MHz,f2=870.2MHz

2)in higher edge test:f1 is the higher edge frequency -2 channel frequency, and f2 is -1 channel frequency

f1=892.8MHz,f2=893.4MHz

base the 3rd product frequency F1= 2f1-f2 and F2=2f2-f1, when the f1 and f2 frequency select above,

c) in lower edge test, F1=2f1-(f1+Δf)=f1-Δf=lower edge frequency;

d) in higher edge test, F2=2f2-(f2-Δf)=f2+Δf=higher edge frequency.

F1=869MHz,F2=894MHz

base the 5th product frequency F1= 3f1-2f2 and F2=3f2-2f1, when the f1 and f2 frequency select above,

c) in lower edge test, F1=3f1-2(f1+Δf)=f1-2Δf=lower edge frequency;

d) in higher edge test, F2=3f2-2(f2-Δf)=f2+2Δf=higher edge frequency.

F1=868.4MHz,F2=894.6MHz

base the 7th product frequency F1= 4f1-3f2 and F2=4f2-3f1, when the f1 and f2 frequency select above,

c) in lower edge test, F1=4f1-3(f1+Δf)=f1-3Δf=lower edge frequency;

d) in higher edge test, F2=4f2-3(f2-Δf)=f2+3Δf=higher edge frequency.

F1=867.8MHz,F2=895.2MHz

Input power:-20dBm

measure frequency		product Value (dBm)	Limit (dBm)	Magin (dB)
3 rd	Lower:869MHz	-14.42	-13dBm	1.42
	Higher:894MHz	-15.01		2.01
5 rd	Lower:868.4MHz	-18.35	-13dBm	5.35
	Higher:894.6MHz	-18.49		5.49
7 rd	Lower:867.8MHz	-19.47	-13dBm	6.47
	Higher:895.2MHz	-19.53		6.53



2.5.2 For CDMA mode:

Input frequency:

1)in lower edge test:f1 is the lower edge frequency +1 channel frequency, and f2 is +2 channel frequency

f1=871MHz,f2=873MHz

2)in higher edge test:f1 is the higher edge frequency -2 channel frequency, and f2 is -1 channel frequency

f1=890MHz,f2=892MHz

base the 3rd product frequency F1= 2f1-f2 and F2=2f2-f1, when the f1 and f2 frequency select above,

e) in lower edge test, F1=2f1-(f1+Δf)=f1-Δf=lower edge frequency;

f) in higher edge test, F2=2f2-(f2-Δf)=f2+Δf=higher edge frequency.

F1=869MHz,F2=894MHz

base the 5th product frequency F1= 3f1-2f2 and F2=3f2-2f1, when the f1 and f2 frequency select above,

e) in lower edge test, F1=3f1-2(f1+Δf)=f1-2Δf=lower edge frequency;

f) in higher edge test, F2=3f2-2(f2-Δf)=f2+2Δf=higher edge frequency.

F1=867MHz,F2=896MHz

base the 7th product frequency F1= 4f1-3f2 and F2=4f2-3f1, when the f1 and f2 frequency select above,

e) in lower edge test, F1=4f1-3(f1+Δf)=f1-3Δf=lower edge frequency;

f) in higher edge test, F2=4f2-3(f2-Δf)=f2+3Δf=higher edge frequency.

F1=865MHz,F2=898MHz

Input power:-20dBm

measure frequency		product Value (dBm)	Limit (dBm)	Magin (dB)
3 rd	Lower:869MHz	-23.04	-13dBm	10.04
	Higher:894MHz	-23.27		10.27
5 rd	Lower:867MHz	-26.48	-13dBm	13.48
	Higher:896MHz	-27.12		14.12
7 rd	Lower:865MHz	-28.59	-13dBm	15.59
	Higher:898MHz	-29.04		16.04

2.5.3 For WCDMA mode:

Input frequency:

1) in lower edge test: f1 is the lower edge frequency +1 channel frequency, and f2 is +2 channel frequency

$$f1=872\text{MHz}, f2=875\text{MHz}$$

2) in higher edge test: f1 is the higher edge frequency -2 channel frequency, and f2 is -1 channel frequency

$$f1=888\text{MHz}, f2=891\text{MHz}$$

base the 3rd product frequency $F1=2f1-f2$ and $F2=2f2-f1$, when the f1 and f2 frequency select above,

g) in lower edge test, $F1=2f1-(f1+\Delta f)=f1-\Delta f$ =lower edge frequency;

h) in higher edge test, $F2=2f2-(f2-\Delta f)=f2+\Delta f$ =higher edge frequency.

$$F1=869\text{MHz}, F2=894\text{MHz}$$

base the 5rd product frequency $F1=3f1-2f2$ and $F2=3f2-2f1$, when the f1 and f2 frequency select above,

g) in lower edge test, $F1=3f1-2(f1+\Delta f)=f1-2\Delta f$ =lower edge frequency;

h) in higher edge test, $F2=3f2-2(f2-\Delta f)=f2+2\Delta f$ =higher edge frequency.

$$F1=866\text{MHz}, F2=897\text{MHz}$$

base the 7rd product frequency $F1=4f1-3f2$ and $F2=4f2-3f1$, when the f1 and f2 frequency select above,

g) in lower edge test, $F1=4f1-3(f1+\Delta f)=f1-3\Delta f$ =lower edge frequency;

h) in higher edge test, $F2=4f2-3(f2-\Delta f)=f2+3\Delta f$ =higher edge frequency.

$$F1=863\text{MHz}, F2=900\text{MHz}$$

Input power:-20dBm

measure frequency		product Value (dBm)	Limit (dBm)	Magin (dB)
3 rd	Lower:869MHz	-22.55	-13dBm	9.55
	Higher:894MHz	-21.46		8.46
5 rd	Lower:866MHz	-27.42	-13dBm	14.42
	Higher:897MHz	-28.09		15.09
7 rd	Lower:863MHz	-29.64	-13dBm	16.64
	Higher:900MHz	-29.58		16.58



2.5.4 For LTE mode:

Input frequency:

1)in lower edge test:f1 is the lower edge frequency +1 channel frequency, and f2 is +2 channel frequency

f1=874MHz,f2=884MHz

2)in higher edge test:f1 is the higher edge frequency -2 channel frequency, and f2 is -1 channel frequency

f1=879MHz,f2=889MHz

base the 3rd product frequency F1= 2f1-f2 and F2=2f2-f1, when the f1 and f2 frequency select above,

- i) in lower edge test, F1=2f1-(f1+Δf)=f1-Δf=lower edge frequency;
j) in higher edge test, F2=2f2-(f2-Δf)=f2+Δf=higher edge frequency.

F1=869MHz,F2=894MHz

base the 5th product frequency F1= 3f1-2f2 and F2=3f2-2f1, when the f1 and f2 frequency select above,

- i) in lower edge test, F1=3f1-2(f1+Δf)=f1-2Δf=lower edge frequency;
j) in higher edge test, F2=3f2-2(f2-Δf)=f2+2Δf=higher edge frequency.

F1=859MHz,F2=904MHz

base the 7th product frequency F1= 4f1-3f2 and F2=4f2-3f1, when the f1 and f2 frequency select above,

- i) in lower edge test, F1=4f1-3(f1+Δf)=f1-3Δf=lower edge frequency;
j) in higher edge test, F2=4f2-3(f2-Δf)=f2+3Δf=higher edge frequency.

F1=849MHz,F2=914MHz

Input power:-20dBm

Table with 4 columns: measure frequency, product Value (dBm), Limit (dBm), and Magin (dB). It contains data for 3rd, 5th, and 7th order intermodulation products, showing lower and higher edge frequencies, their product values, a -13dBm limit, and resulting margins of 9.06, 9.32, 20.59, 20.65, 21.67, and 21.89 dB.

Remark:

No other intermodulation spurious emissions of above 7th have been found,so only record the test data about the 3rd, 5th and 7th

3. Downlink: 1930MHz to 1995MHz(GSM,CDMA,WCDMA,LTE)

3.1 GSM Mode:

3.1.1 two signal input —Lower Edge

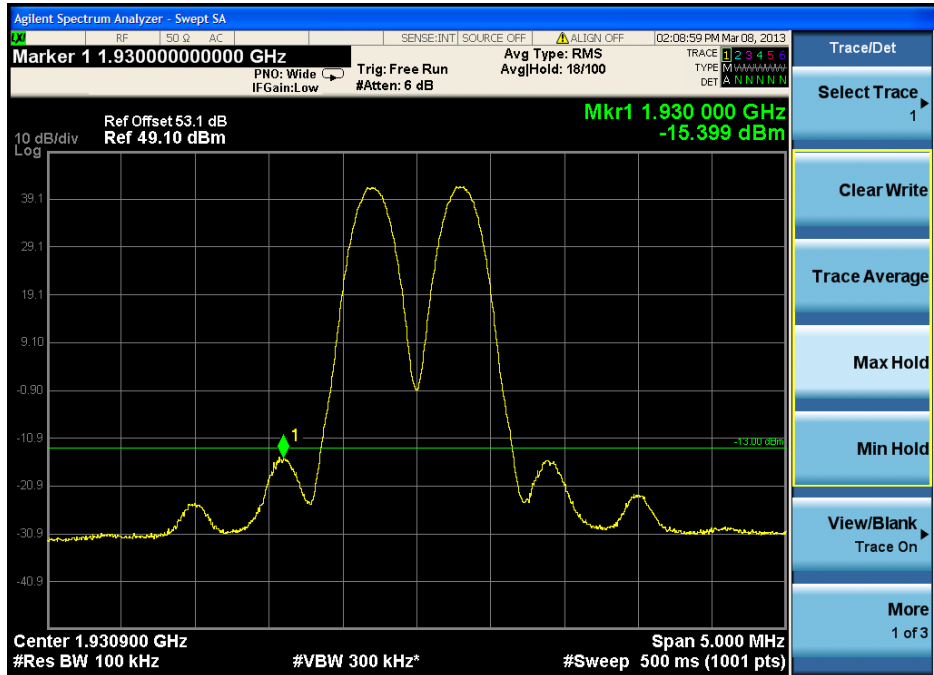

3.1.2 two signal input —Upper Edge

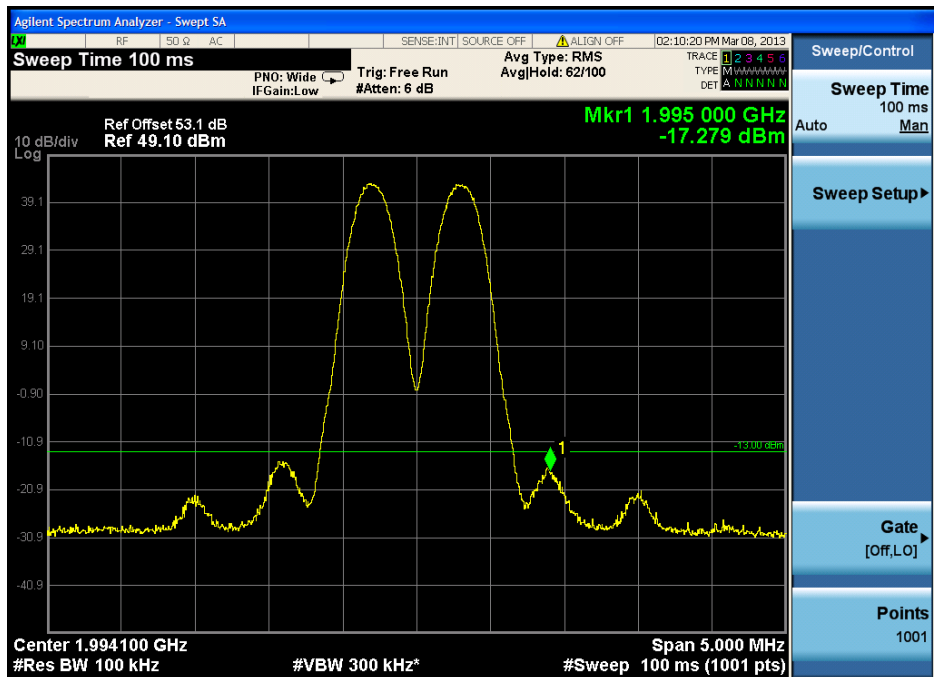



3.2 CDMA Mode:

3.2.1 two signal input —Lower Edge

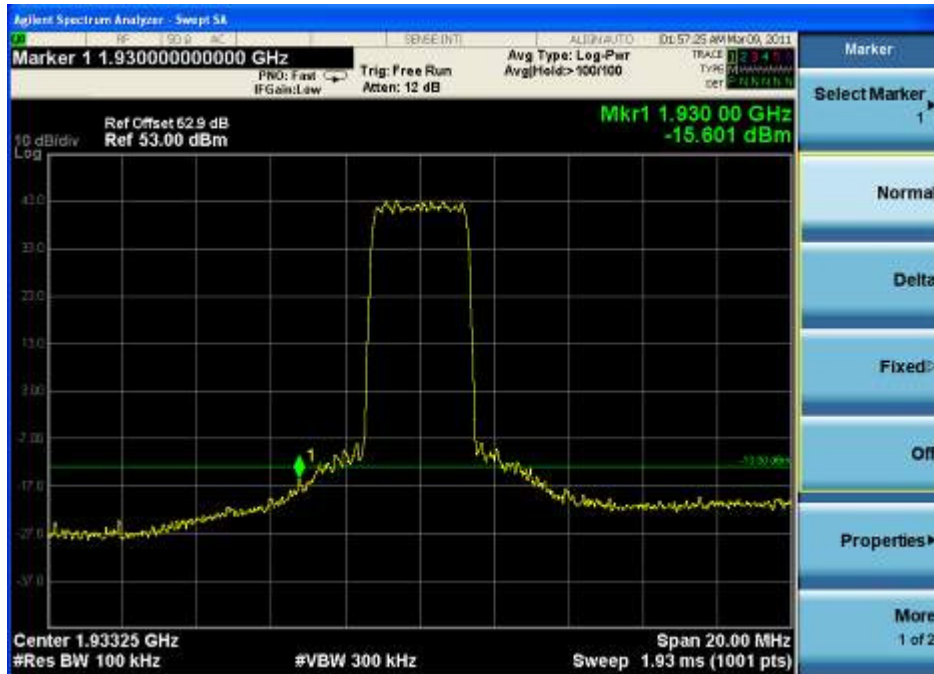

3.2.2 two signal input —Upper Edge



3.3 WDMA Mode:

3.3.1 two signal input —Lower Edge

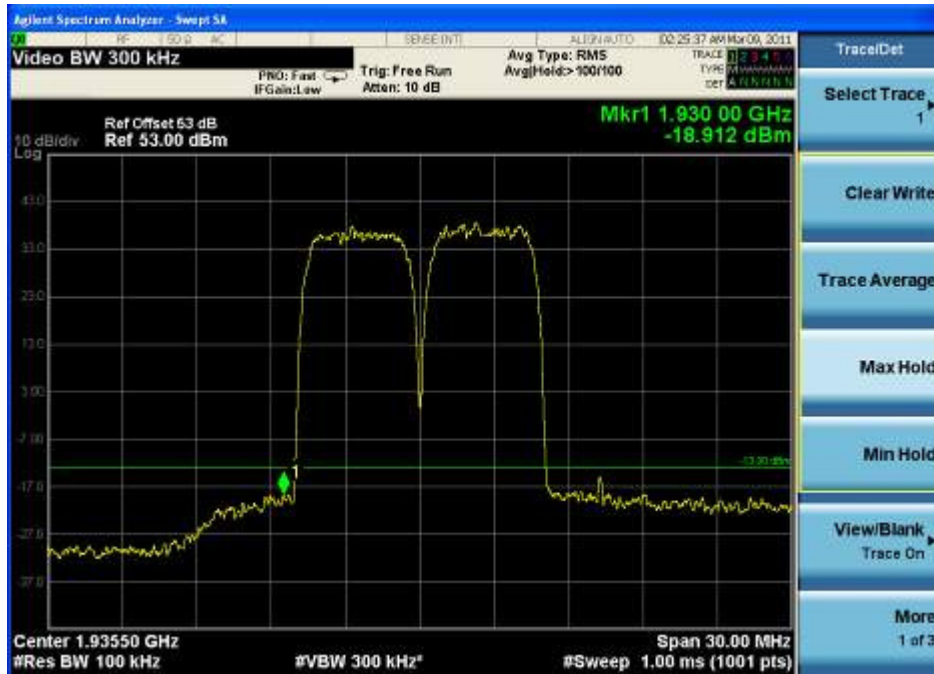

3.3.2 two signal input —Upper Edge

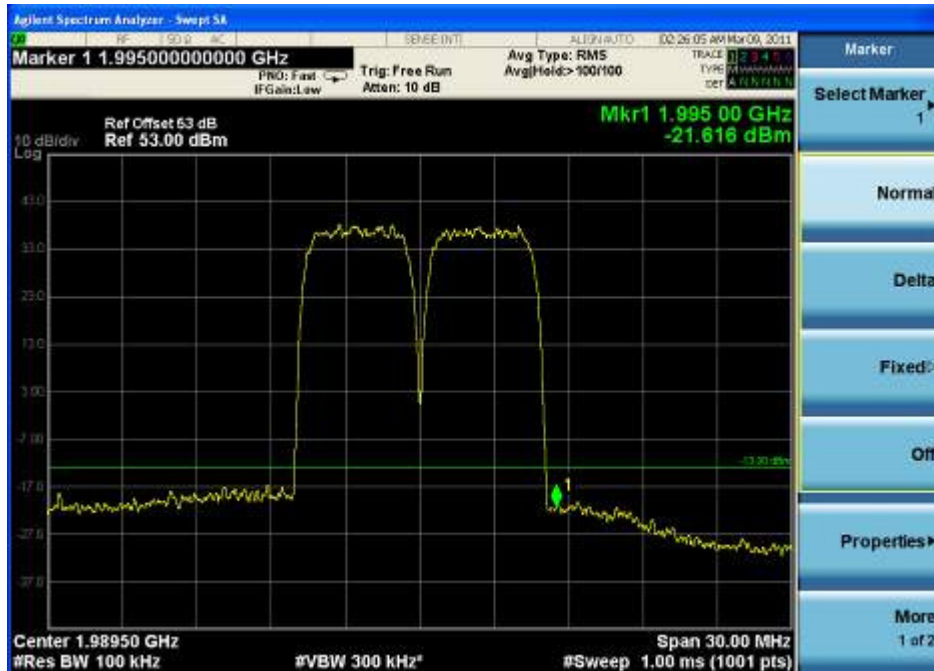



3.4 LTE Mode:

3.4.1 two signal input —Lower Edge

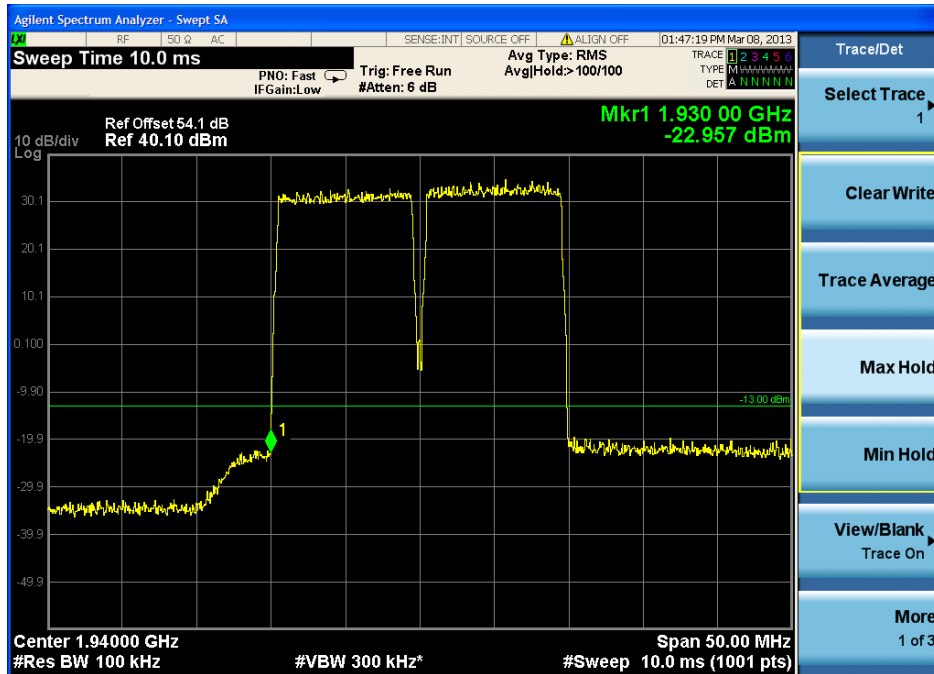

3.4.2 two signal input —Upper Edge

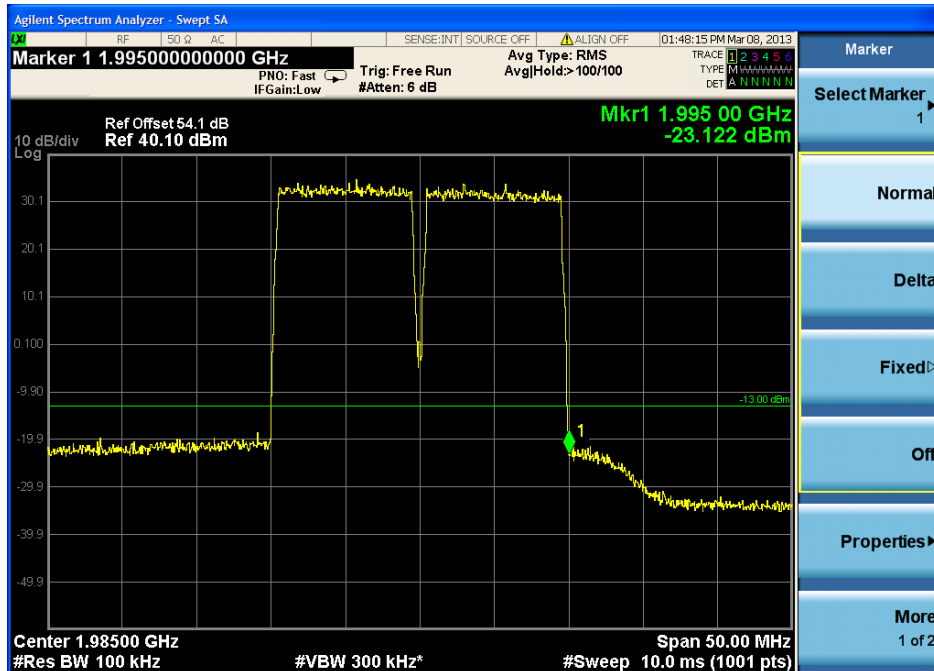



3.5 intermodulation spurious emissions

3.5.1 For GSM mode:

Input frequency:

1)in lower edge test:f1 is the lower edge frequency +1 channel frequency, and f2 is +2 channel frequency

f1=1930.6MHz,f2=1931.2MHz

2)in higher edge test:f1 is the higher edge frequency -2 channel frequency, and f2 is -1 channel frequency

f1=1994MHz,f2=1994.6MHz

base the 3rd product frequency F1= 2f1-f2 and F2=2f2-f1, when the f1 and f2 frequency select above,

k) in lower edge test, F1=2f1-(f1+Δf)=f1-Δf=lower edge frequency;

l) in higher edge test, F2=2f2-(f2-Δf)=f2+Δf=higher edge frequency.

F1=1930MHz,F2=1995MHz

base the 5rd product frequency F1= 3f1-2f2 and F2=3f2-2f1, when the f1 and f2 frequency select above,

k) in lower edge test, F1=3f1-2(f1+Δf)=f1-2Δf=lower edge frequency;

l) in higher edge test, F2=3f2-2(f2-Δf)=f2+2Δf=higher edge frequency.

F1=1929.4MHz,F2=1995.6MHz

base the 7rd product frequency F1= 4f1-3f2 and F2=4f2-3f1, when the f1 and f2 frequency select above,

k) in lower edge test, F1=4f1-3(f1+Δf)=f1-3Δf=lower edge frequency;

l) in higher edge test, F2=4f2-3(f2-Δf)=f2+3Δf=higher edge frequency.

F1=1928.8MHz,F2=1996.2MHz

Input power:-20dBm

measure frequency		product Value (dBm)	Limit (dBm)	Magin (dB)
3 rd	Lower:1930MHz	-15.39	-13dBm	2.39
	Higher:1995MHz	-17.28		4.28
5 rd	Lower:1929.4MHz	-25.43	-13dBm	12.43
	Higher:1995.6MHz	-23.49		10.49
7 rd	Lower:1928.8MHz	-29.98	-13dBm	16.98
	Higher:1996.2MHz	-29.84		16.84



3.5.2 For CDMA mode:

Input frequency:

1)in lower edge test:f1 is the lower edge frequency +1 channel frequency, and f2 is +2 channel frequency

f1=1930MHz,f2=1932MHz

2)in higher edge test:f1 is the higher edge frequency -2 channel frequency, and f2 is -1 channel frequency

f1=1991MHz,f2=1993MHz

base the 3rd product frequency F1= 2f1-f2 and F2=2f2-f1, when the f1 and f2 frequency select above,

m) in lower edge test, F1=2f1-(f1+Δf)=f1-Δf=lower edge frequency;

n) in higher edge test, F2=2f2-(f2-Δf)=f2+Δf=higher edge frequency.

F1=1930MHz,F2=1995MHz

base the 5th product frequency F1= 3f1-2f2 and F2=3f2-2f1, when the f1 and f2 frequency select above,

m) in lower edge test, F1=3f1-2(f1+Δf)=f1-2Δf=lower edge frequency;

n) in higher edge test, F2=3f2-2(f2-Δf)=f2+2Δf=higher edge frequency.

F1=1928MHz,F2=1997MHz

base the 7th product frequency F1= 4f1-3f2 and F2=4f2-3f1, when the f1 and f2 frequency select above,

m) in lower edge test, F1=4f1-3(f1+Δf)=f1-3Δf=lower edge frequency;

n) in higher edge test, F2=4f2-3(f2-Δf)=f2+3Δf=higher edge frequency.

F1=1926MHz,F2=1999MHz

Input power:-20dBm

measure frequency		product Value (dBm)	Limit (dBm)	Magin (dB)
3 rd	Lower:1930MHz	-15.61	-13dBm	2.61
	Higher:1995MHz	-18.78		5.78
5 rd	Lower:1928MHz	-27.59	-13dBm	14.59
	Higher:1997MHz	-26.84		13.84
7 rd	Lower:1926MHz	-29.04	-13dBm	16.04
	Higher:1999MHz	-29.13		16.13



3.5.3 For WCDMA mode:

Input frequency:

1)in lower edge test:f1 is the lower edge frequency +1 channel frequency, and f2 is +2 channel frequency

$$f1=1933\text{MHz}, f2=1936\text{MHz}$$

2)in higher edge test:f1 is the higher edge frequency -2 channel frequency, and f2 is -1 channel frequency

$$f1=1989\text{MHz}, f2=1992\text{MHz}$$

base the 3rd product frequency $F1=2f1-f2$ and $F2=2f2-f1$, when the f1 and f2 frequency select above,

o) in lower edge test, $F1=2f1-(f1+\Delta f)=f1-\Delta f$ =lower edge frequency;

p) in higher edge test, $F2=2f2-(f2-\Delta f)=f2+\Delta f$ =higher edge frequency.

$$F1=1930\text{MHz}, F2=1995\text{MHz}$$

base the 5rd product frequency $F1=3f1-2f2$ and $F2=3f2-2f1$, when the f1 and f2 frequency select above,

o) in lower edge test, $F1=3f1-2(f1+\Delta f)=f1-2\Delta f$ =lower edge frequency;

p) in higher edge test, $F2=3f2-2(f2-\Delta f)=f2+2\Delta f$ =higher edge frequency.

$$F1=1927\text{MHz}, F2=1998\text{MHz}$$

base the 7rd product frequency $F1=4f1-3f2$ and $F2=4f2-3f1$, when the f1 and f2 frequency select above,

o) in lower edge test, $F1=4f1-3(f1+\Delta f)=f1-3\Delta f$ =lower edge frequency;

p) in higher edge test, $F2=4f2-3(f2-\Delta f)=f2+3\Delta f$ =higher edge frequency.

$$F1=1924\text{MHz}, F2=2001\text{MHz}$$

Input power:-20dBm

measure frequency		product Value (dBm)	Limit (dBm)	Magin (dB)
3 rd	Lower:1930MHz	-18.91	-13dBm	5.91
	Higher:1995MHz	-21.62		8.62
5 rd	Lower:1927MHz	-26.84	-13dBm	13.84
	Higher:1998MHz	-26.95		13.95
7 rd	Lower:1924MHz	-28.56	-13dBm	15.56
	Higher:2001MHz	-29.41		16.41



3.5.4 For LTE mode:

Input frequency:

1)in lower edge test:f1 is the lower edge frequency +1 channel frequency, and f2 is +2 channel frequency

f1=1935MHz,f2=1945MHz

2)in higher edge test:f1 is the higher edge frequency -2 channel frequency, and f2 is -1 channel frequency

f1=1980MHz,f2=1990MHz

base the 3rd product frequency F1= 2f1-f2 and F2=2f2-f1, when the f1 and f2 frequency select above,

q) in lower edge test, F1=2f1-(f1+Δf)=f1-Δf=lower edge frequency;

r) in higher edge test, F2=2f2-(f2-Δf)=f2+Δf=higher edge frequency.

F1=1930MHz,F2=1995MHz

base the 5th product frequency F1= 3f1-2f2 and F2=3f2-2f1, when the f1 and f2 frequency select above,

q) in lower edge test, F1=3f1-2(f1+Δf)=f1-2Δf=lower edge frequency;

r) in higher edge test, F2=3f2-2(f2-Δf)=f2+2Δf=higher edge frequency.

F1=1920MHz,F2=2005MHz

base the 7th product frequency F1= 4f1-3f2 and F2=4f2-3f1, when the f1 and f2 frequency select above,

q) in lower edge test, F1=4f1-3(f1+Δf)=f1-3Δf=lower edge frequency;

r) in higher edge test, F2=4f2-3(f2-Δf)=f2+3Δf=higher edge frequency.

F1=1910MHz,F2=2015MHz

Input power:-20dBm

measure frequency		product Value (dBm)	Limit (dBm)	Magin (dB)
3 rd	Lower:1930MHz	-22.96	-13dBm	9.96
	Higher:1995MHz	-23.12		10.12
5 rd	Lower:1920MHz	-34.58	-13dBm	21.58
	Higher:2005MHz	-29.94		16.94
7 rd	Lower:1920MHz	-35.36	-13dBm	22.36
	Higher:2015MHz	-34.85		21.85

Remark:

No other intermodulation spurious emissions of above 7rd have been found,so only record the test data about the 3rd, 5rd and 7rd

4. Downlink: 2110MHz to 2155MHz(CDMA,WCDMA,LTE)

4.1 CDMA Mode:

4.1.1 two signal input —Lower Edge

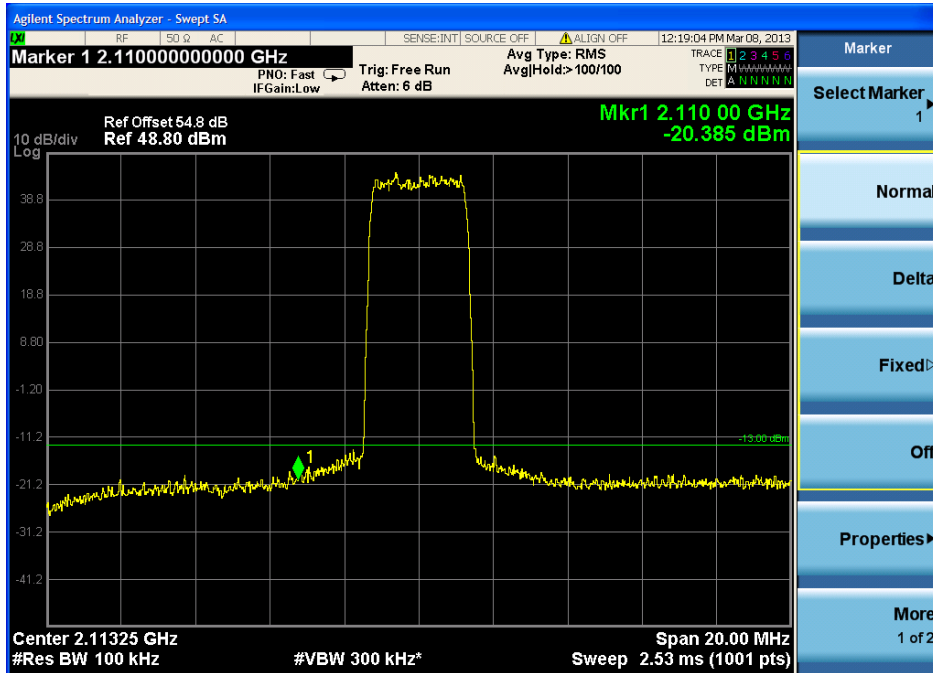

4.1.2 two signal input —Upper Edge

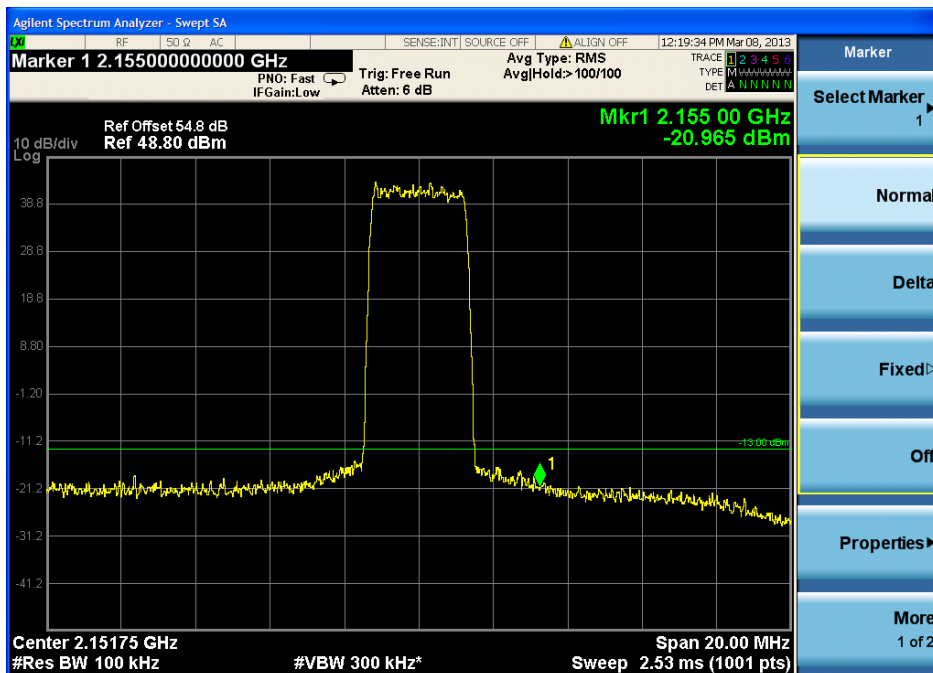



4.2 WDMA Mode:

4.2.1 two signal input —Lower Edge

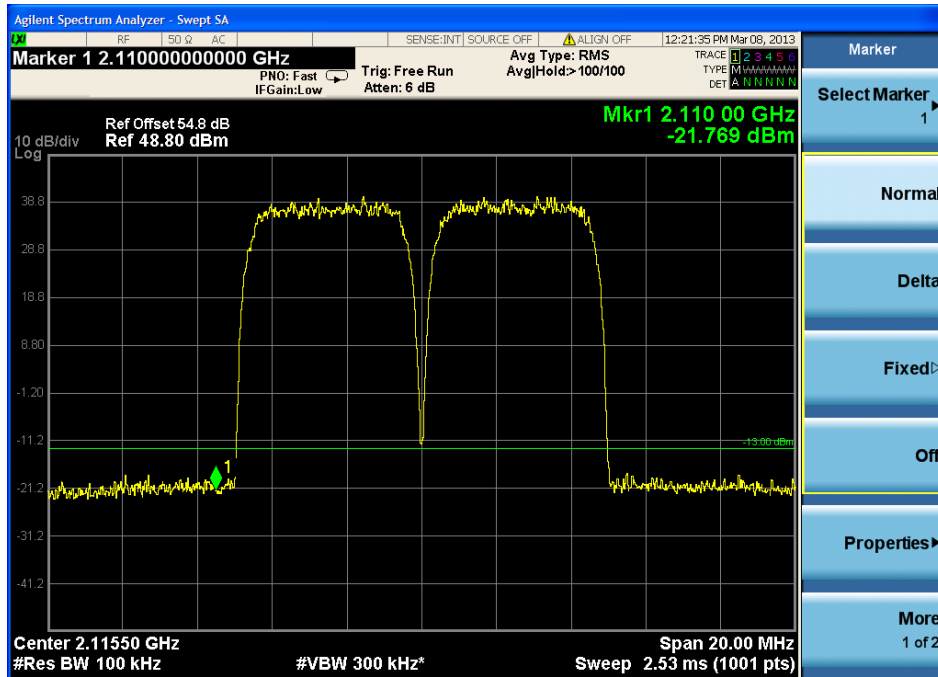

4.2.2 two signal input —Upper Edge

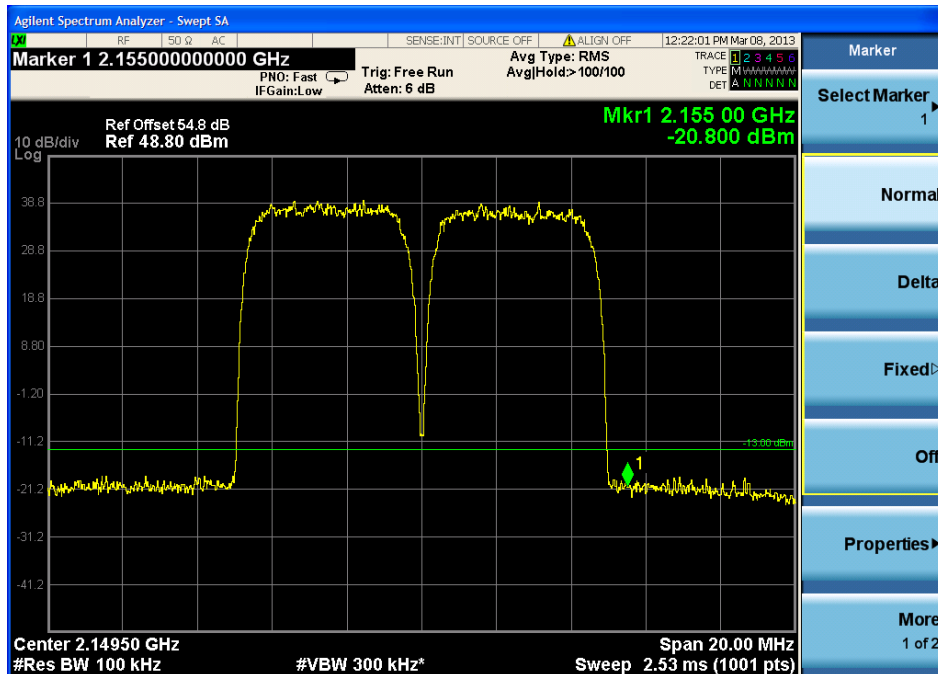



4.3 LTE Mode:

4.3.1 two signal input —Lower Edge

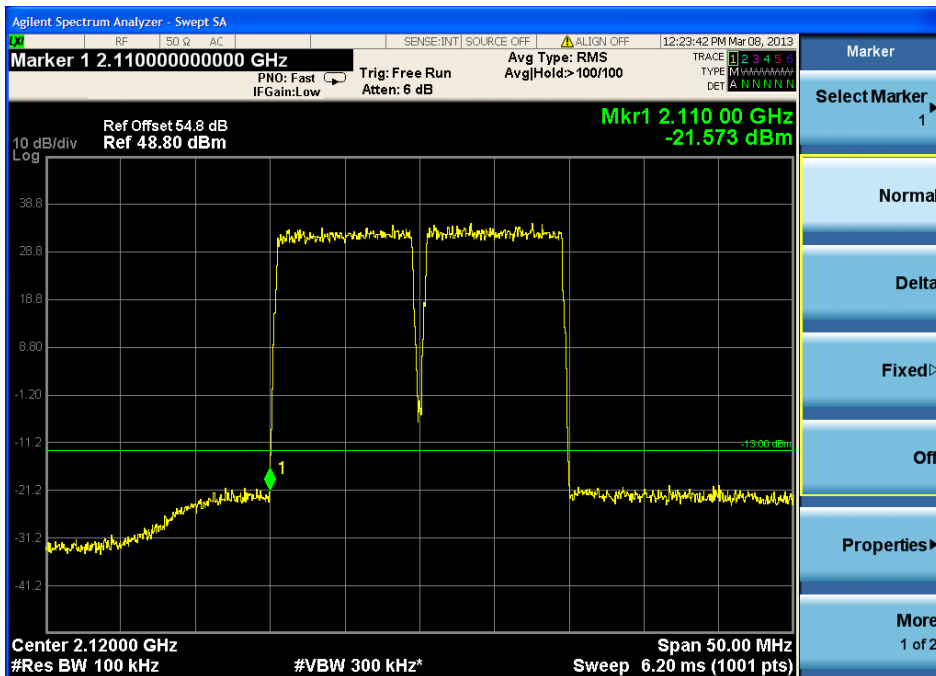

4.3.2 two signal input —Upper Edge

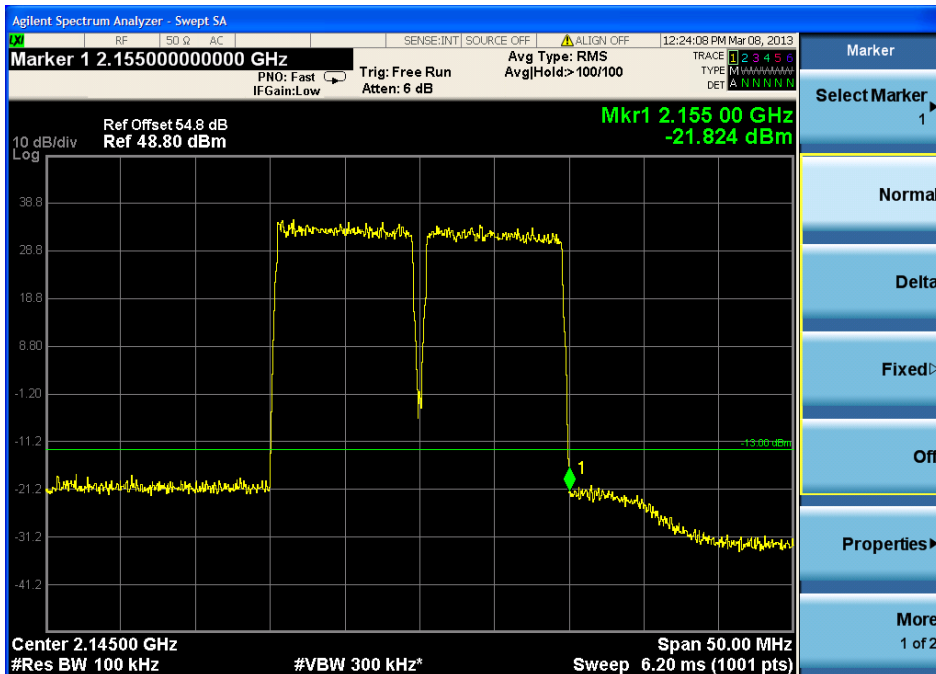



4.4 intermodulation spurious emissions

4.4.1 For CDMA mode:

Input frequency:

1)in lower edge test:f1 is the lower edge frequency +1 channel frequency, and f2 is +2 channel frequency

f1=2112MHz,f2=2114MHz

2)in higher edge test:f1 is the higher edge frequency -2 channel frequency, and f2 is -1 channel frequency

f1=2151MHz,f2=2153MHz

base the 3rd product frequency F1= 2f1-f2 and F2=2f2-f1, when the f1 and f2 frequency select above,

s) in lower edge test, F1=2f1-(f1+Δf)=f1-Δf=lower edge frequency;

t) in higher edge test, F2=2f2-(f2-Δf)=f2+Δf=higher edge frequency.

F1=2110MHz,F2=2155MHz

base the 5rd product frequency F1= 3f1-2f2 and F2=3f2-2f1, when the f1 and f2 frequency select above,

s) in lower edge test, F1=3f1-2(f1+Δf)=f1-2Δf=lower edge frequency;

t) in higher edge test, F2=3f2-2(f2-Δf)=f2+2Δf=higher edge frequency.

F1=2108MHz,F2=2157MHz

base the 7rd product frequency F1= 4f1-3f2 and F2=4f2-3f1, when the f1 and f2 frequency select above,

s) in lower edge test, F1=4f1-3(f1+Δf)=f1-3Δf=lower edge frequency;

t) in higher edge test, F2=4f2-3(f2-Δf)=f2+3Δf=higher edge frequency.

F1=2106MHz,F2=2159MHz

Input power:-20dBm

measure frequency		product Value (dBm)	Limit (dBm)	Magin (dB)
3 rd	Lower:2110MHz	-20.39	-13dBm	7.39
	Higher:2155MHz	-20.97		7.97
5 rd	Lower:2108MHz	-21.36	-13dBm	8.36
	Higher:2157MHz	-22.48		9.48
7 rd	Lower:2106MHz	-25.48	-13dBm	12.48
	Higher:2159MHz	-24.96		11.96



4.4.2 For WCDMA mode:

Input frequency:

1)in lower edge test:f1 is the lower edge frequency +1 channel frequency, and f2 is +2 channel frequency

f1=2113MHz,f2=2116MHz

2)in higher edge test:f1 is the higher edge frequency -2 channel frequency, and f2 is -1 channel frequency

f1=2149MHz,f2=2152MHz

base the 3rd product frequency F1= 2f1-f2 and F2=2f2-f1, when the f1 and f2 frequency select above,

u) in lower edge test, F1=2f1-(f1+Δf)=f1-Δf=lower edge frequency;

v) in higher edge test, F2=2f2-(f2-Δf)=f2+Δf=higher edge frequency.

F1=2110MHz,F2=2155MHz

base the 5rd product frequency F1= 3f1-2f2 and F2=3f2-2f1, when the f1 and f2 frequency select above,

u) in lower edge test, F1=3f1-2(f1+Δf)=f1-2Δf=lower edge frequency;

v) in higher edge test, F2=3f2-2(f2-Δf)=f2+2Δf=higher edge frequency.

F1=2107MHz,F2=2158MHz

base the 7rd product frequency F1= 4f1-3f2 and F2=4f2-3f1, when the f1 and f2 frequency select above,

u) in lower edge test, F1=4f1-3(f1+Δf)=f1-3Δf=lower edge frequency;

v) in higher edge test, F2=4f2-3(f2-Δf)=f2+3Δf=higher edge frequency.

F1=2104MHz,F2=2161MHz

Input power:-20dBm

measure frequency		product Value (dBm)	Limit (dBm)	Magin (dB)
3 rd	Lower:2110MHz	-21.77	-13dBm	8.77
	Higher:2155MHz	-20.81		7.81
5 rd	Lower:2107MHz	-22.35	-13dBm	9.35
	Higher:2158MHz	-22.46		9.46
7 rd	Lower:2104MHz	-23.14	-13dBm	10.14
	Higher:2161MHz	-23.53		10.53

4.4.3 For LTE mode:

Input frequency:

1) in lower edge test: f1 is the lower edge frequency +1 channel frequency, and f2 is +2 channel frequency

$$f1=2115\text{MHz}, f2=2125\text{MHz}$$

2) in higher edge test: f1 is the higher edge frequency -2 channel frequency, and f2 is -1 channel frequency

$$f1=2140\text{MHz}, f2=2150\text{MHz}$$

base the 3rd product frequency $F1=2f1-f2$ and $F2=2f2-f1$, when the f1 and f2 frequency select above,

w) in lower edge test, $F1=2f1-(f1+\Delta f)=f1-\Delta f$ =lower edge frequency;

x) in higher edge test, $F2=2f2-(f2-\Delta f)=f2+\Delta f$ =higher edge frequency.

$$F1=2110\text{MHz}, F2=2155\text{MHz}$$

base the 5rd product frequency $F1=3f1-2f2$ and $F2=3f2-2f1$, when the f1 and f2 frequency select above,

w) in lower edge test, $F1=3f1-2(f1+\Delta f)=f1-2\Delta f$ =lower edge frequency;

x) in higher edge test, $F2=3f2-2(f2-\Delta f)=f2+2\Delta f$ =higher edge frequency.

$$F1=2100\text{MHz}, F2=2165\text{MHz}$$

base the 7rd product frequency $F1=4f1-3f2$ and $F2=4f2-3f1$, when the f1 and f2 frequency select above,

w) in lower edge test, $F1=4f1-3(f1+\Delta f)=f1-3\Delta f$ =lower edge frequency;

x) in higher edge test, $F2=4f2-3(f2-\Delta f)=f2+3\Delta f$ =higher edge frequency.

$$F1=2090\text{MHz}, F2=2175\text{MHz}$$

Input power:-20dBm

measure frequency		product Value (dBm)	Limit (dBm)	Magin (dB)
3 rd	Lower:2110MHz	-21.57	-13dBm	8.57
	Higher:2155MHz	-21.83		8.83
5 rd	Lower:2100MHz	-27.36	-13dBm	14.36
	Higher:2165MHz	-25.34		12.34
7 rd	Lower:2090MHz	-33.47	-13dBm	20.47
	Higher:2175MHz	-31.98		18.98

Remark:

No other intermodulation spurious emissions of above 7rd have been found, so only record the test data about the 3rd, 5rd and 7rd



Remark:

For the test in two signal input or intermodulation, test input signal f1 and f2 will consider as follows conditions:

- 2) EUT frequency band span and the amount of channels;
- 3) f1 is the frequency lower, f2 is the frequency higher, Δf is the channel spacing;
- 4) in lower edge test, f1 is the lower edge frequency +1 channel frequency, and f2 is +2 channel frequency;
- 5) in higher edge test, f1 is the higher edge frequency -2 channel frequency, and f2 is -1 channel frequency;
- 6) according to the amplifier characteristic, the 3rd product will appear when two signals input;
- 7) base the 3rd product frequency $F1=2f1-f2$ and $F2=2f2-f1$, when the f1 and f2 frequency select above,
 - a) in lower edge test, $F1=2f1-(f1+\Delta f)=f1-\Delta f$ =lower edge frequency;
 - b) in higher edge test, $F2=2f2-(f2-\Delta f)=f2+\Delta f$ =higher edge frequency.
- 8) base the 5rd product frequency $F1=3f1-2f2$ and $F2=3f2-2f1$, when the f1 and f2 frequency select above,
 - a) in lower edge test, $F1=3f1-2(f1+\Delta f)=f1-2\Delta f$ =lower edge frequency;
 - b) in higher edge test, $F2=3f2-2(f2-\Delta f)=f2+2\Delta f$ =higher edge frequency.
- 9) base the 7rd product frequency $F1=4f1-3f2$ and $F2=4f2-3f1$, when the f1 and f2 frequency select above,
 - a) in lower edge test, $F1=4f1-3(f1+\Delta f)=f1-3\Delta f$ =lower edge frequency;
 - b) in higher edge test, $F2=4f2-3(f2-\Delta f)=f2+3\Delta f$ =higher edge frequency.

7.2.4 Conducted Spurious Emissions

Test Requirement: RSS-131 clause 6.4

Test Limit: Spurious emissions of zone enhancers and translators shall be suppressed as much as possible.

Spurious emissions shall be attenuated below the rated power of the enhancer by at least:
 $43 + 10 \text{ Log } 10 (P \text{ rated in watts})$, or 70 dB, whichever is less stringent.
 (-13dBm is the less stringent value)

Test Method: RSS-131 clause 4.4.1

EUT Operation:

Status: Drive the EUT to maximum output power.

Conditions: Normal conditions

Application: RF output ports

Test Configuration:

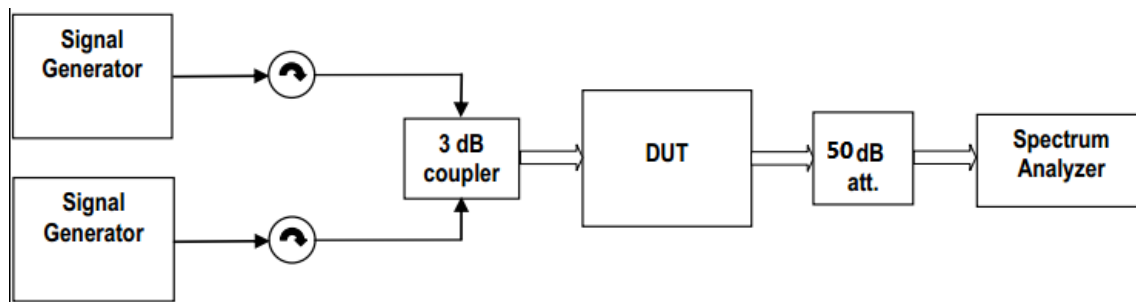

Test Procedure: Conducted Emissions test procedure:

1. The spurious emissions of the equipment under test shall be measured using the two-tone method in section 4.3.1, with the two tones Po1 and Po2 set to the required levels.
2. Using a spectrum analyser with a resolution bandwidth set at 100 kHz, search for spurious emissions from 30 MHz to at least 5 times the highest RF pass band frequency. The search may omit the band that contains the test tones and intermodulation products.



7.2.4.1 Measurement Record:

1. Downlink: 728MHz ~ 756MHz(LTE)

1.1 lowest frequency:

9KHz to 1GHz

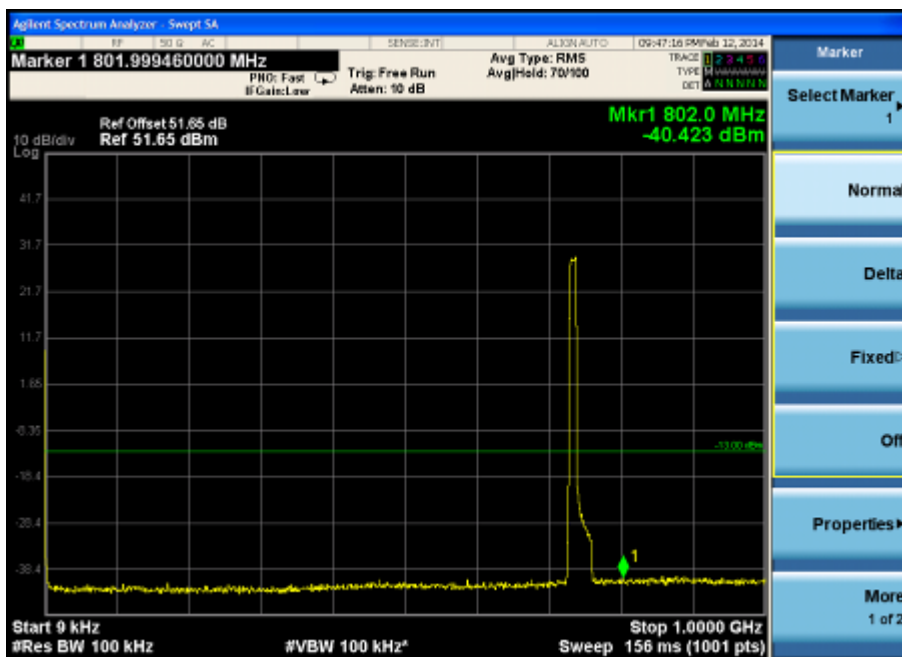

1GHz to 10GHz

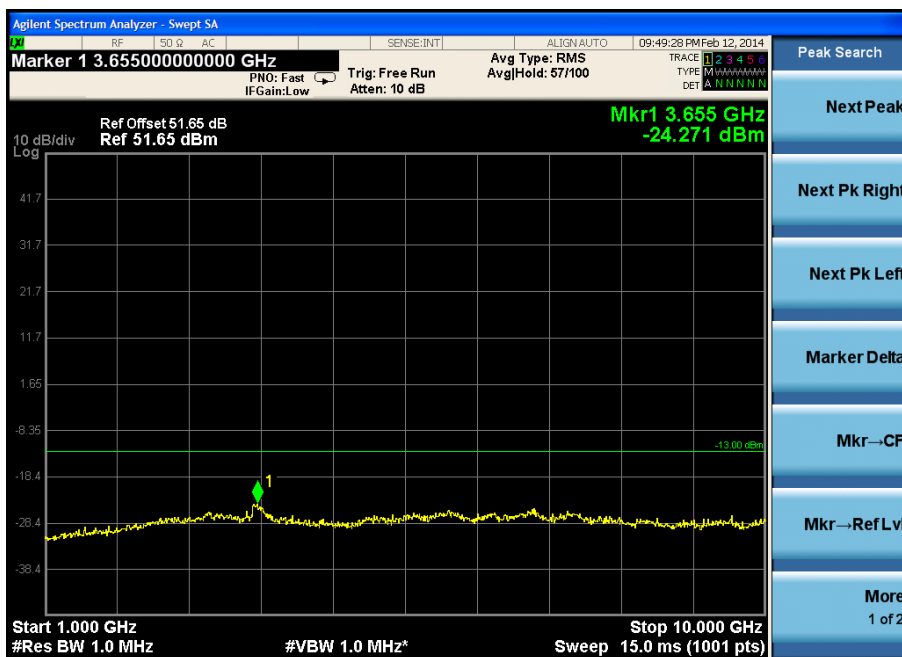



1.2 Middle frequency

9KHz to 1GHz

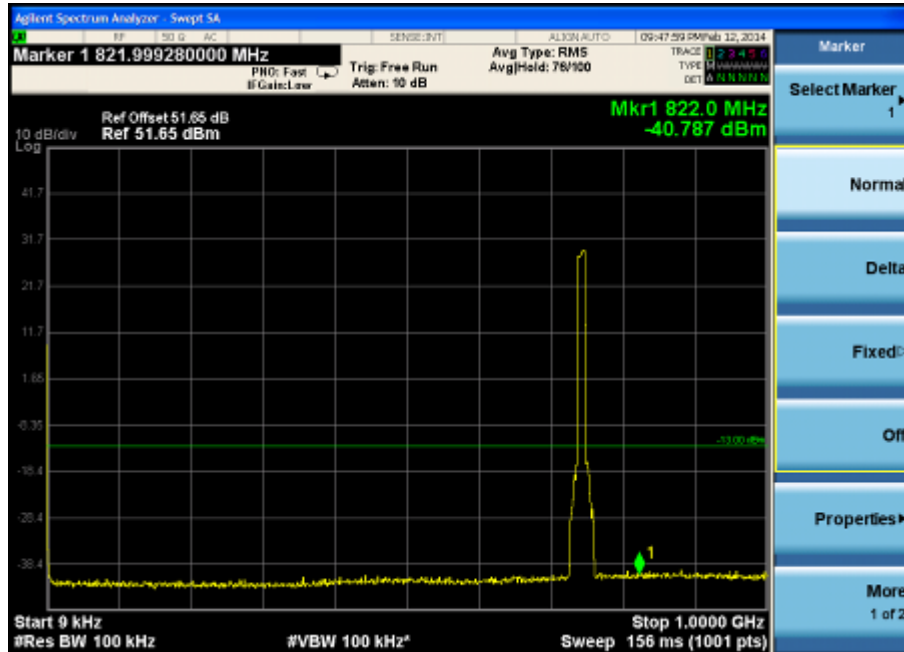

1GHz to 10GHz

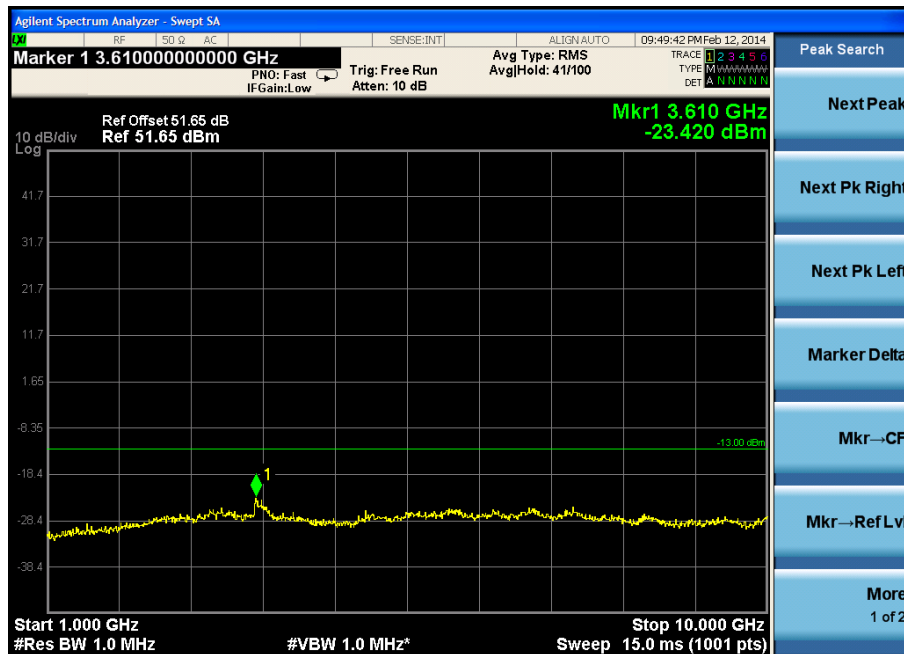



1.3 highest frequency

9KHz to 1GHz

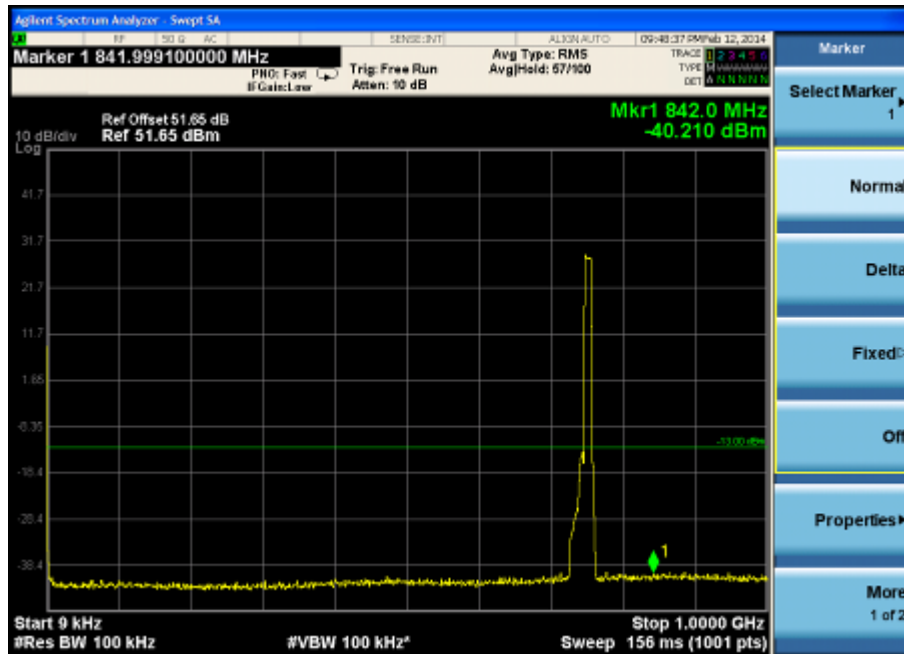

1GHz to 10GHz

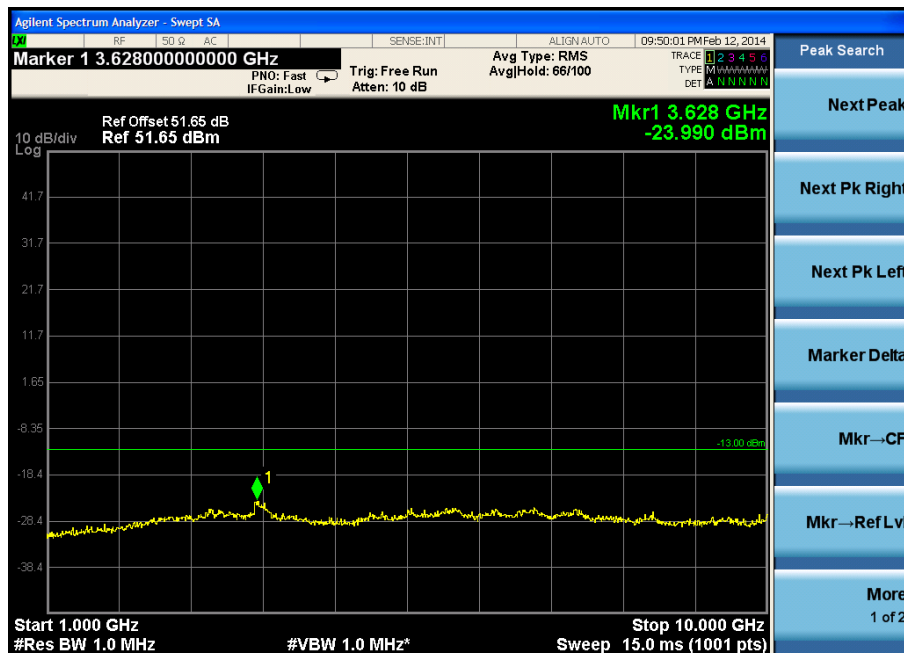



2. Downlink: 869MHz ~ 894MHz

2.1 For LTE mode:

1) lowest frequency

9KHz to 1GHz

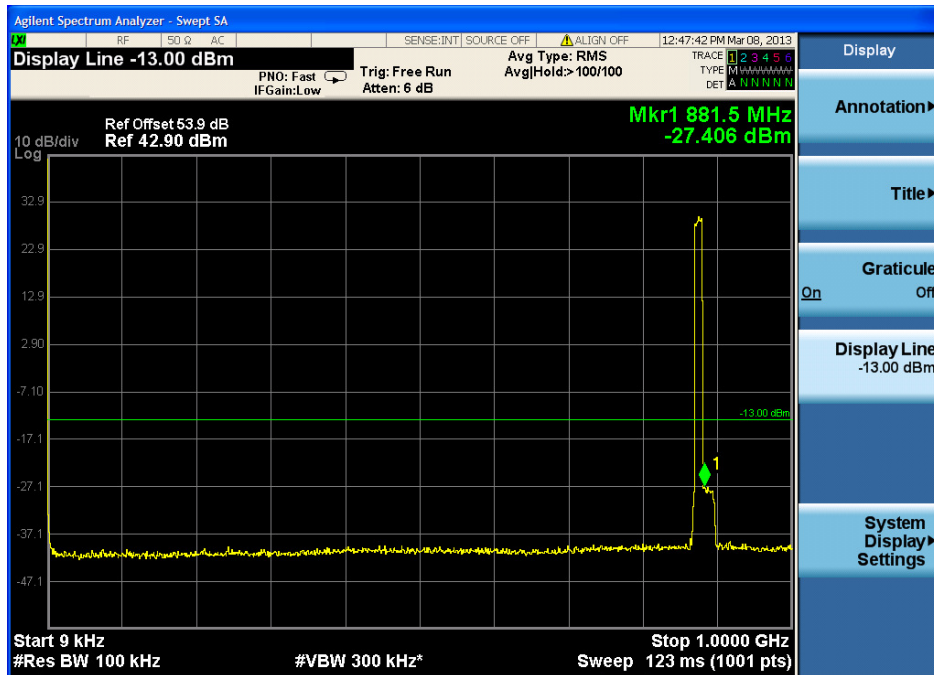

1GHz to 10GHz

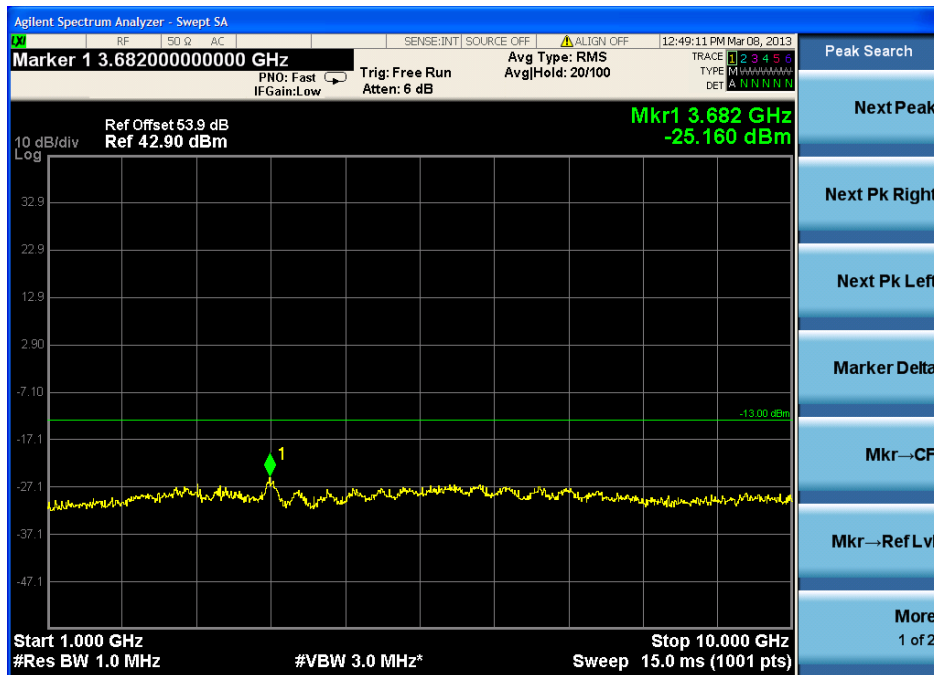



2)Middle frequency

9KHz to 1GHz

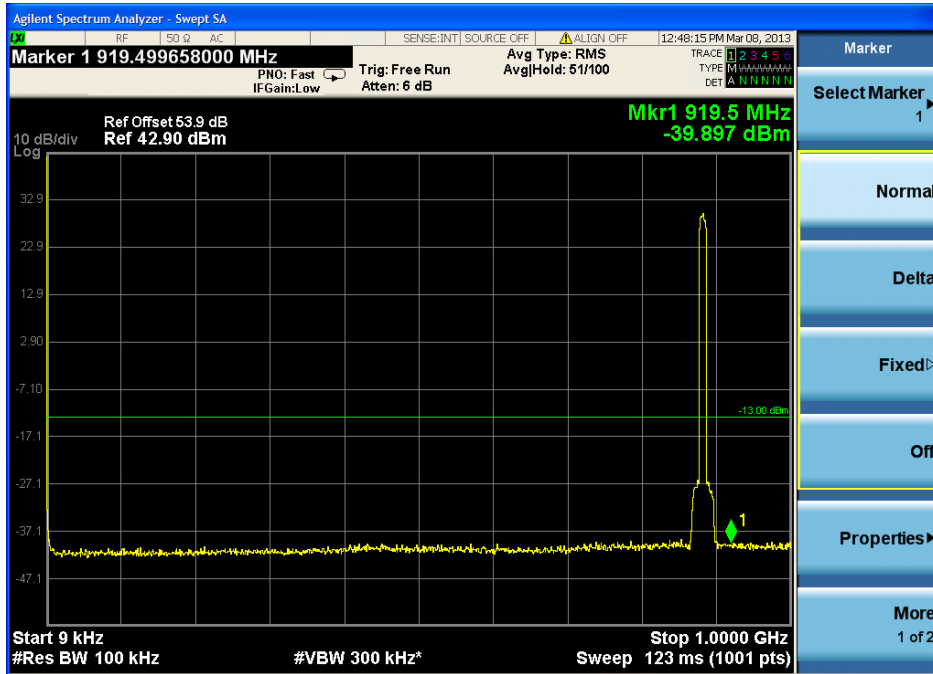

1GHz to 10GHz

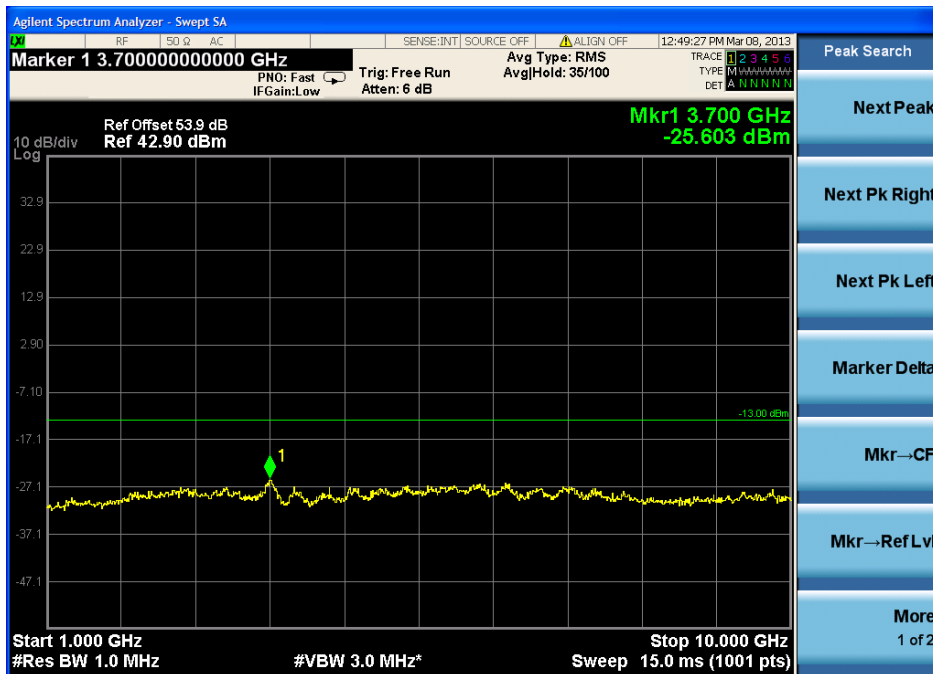



3)highest frequency
9KHz to 1GHz

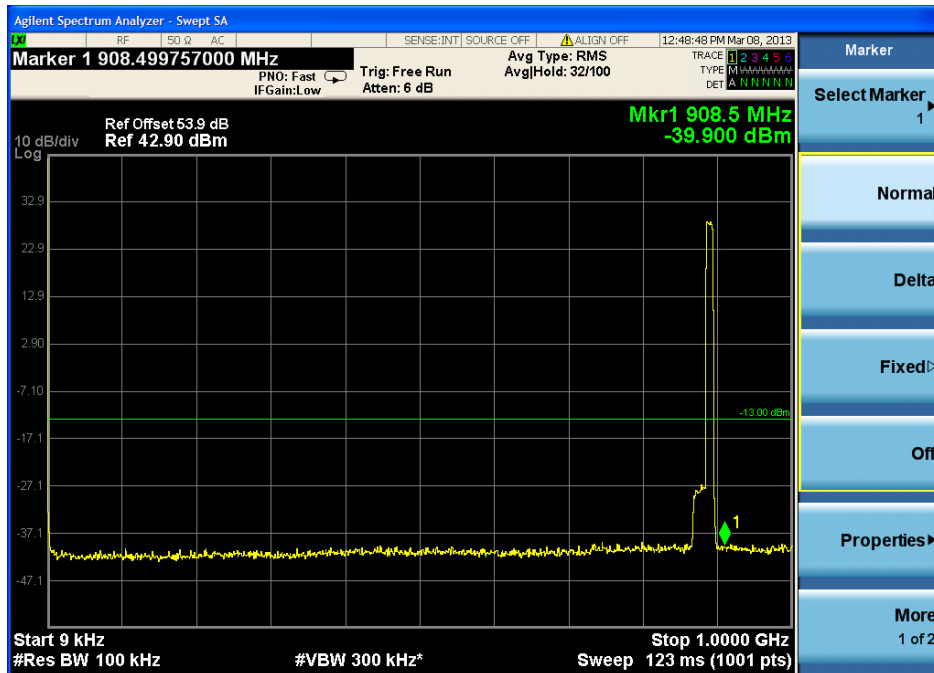

1GHz to 10GHz

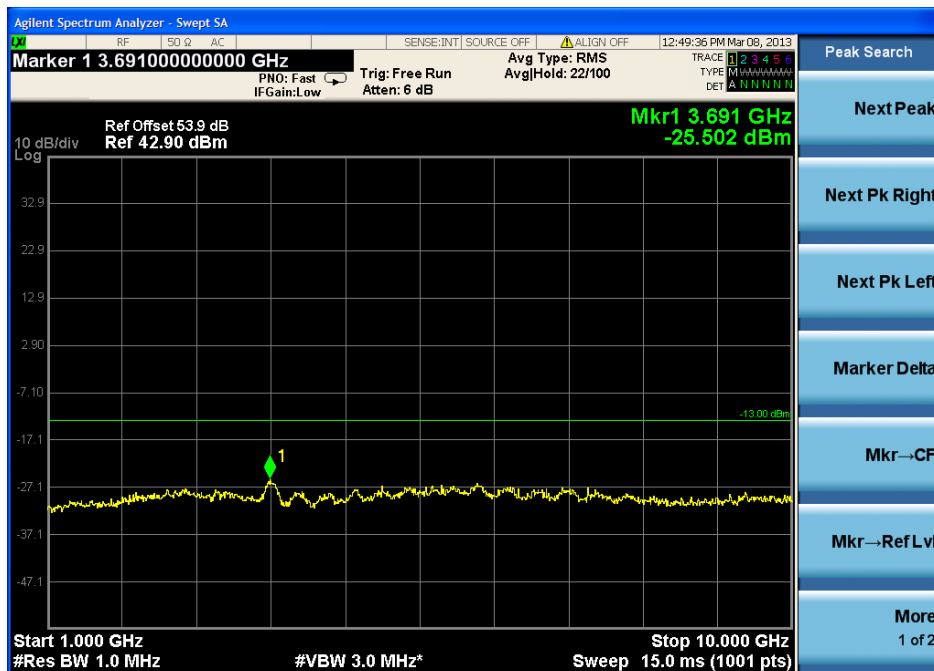



2.2 For GSM mode:

1)lowest frequency:

Measurement Record:				
Frequency range	Measurement bandwidth	Spurious Emission Level(dBm)	Limit(dBm)	Over Limit(dB)
9KHz to 1GHz	RBW=100KHz	-39.98	-13.0	-26.98
1GHz to 10GHz	RBW=1MHz	-26.21	-13.0	-13.21

2)Middle frequency:

Measurement Record:				
Frequency range	Measurement bandwidth	Spurious Emission Level(dBm)	Limit(dBm)	Over Limit(dB)
9KHz to 1GHz	RBW=100KHz	-39.96	-13.0	-26.96
1GHz to 10GHz	RBW=1MHz	-26.34	-13.0	-13.34

3)highest frequency

Measurement Record:				
Frequency range	Measurement bandwidth	Spurious Emission Level(dBm)	Limit(dBm)	Over Limit(dB)
9KHz to 1GHz	RBW=100KHz	-40.01	-13.0	-27.01
1GHz to 10GHz	RBW=1MHz	-26.32	-13.0	-13.32



2.3 For CDMA mode:

1)lowest frequency:

Measurement Record:				
Frequency range	Measurement bandwidth	Spurious Emission Level(dBm)	Limit(dBm)	Over Limit(dB)
9KHz to 1GHz	RBW=100KHz	-39.97	-13.0	-26.97
1GHz to 10GHz	RBW=1MHz	-26.13	-13.0	-13.13

2)Middle frequency:

Measurement Record:				
Frequency range	Measurement bandwidth	Spurious Emission Level(dBm)	Limit(dBm)	Over Limit(dB)
9KHz to 1GHz	RBW=100KHz	-40.12	-13.0	-27.12
1GHz to 10GHz	RBW=1MHz	-26.04	-13.0	-13.04

3)highest frequency

Measurement Record:				
Frequency range	Measurement bandwidth	Spurious Emission Level(dBm)	Limit(dBm)	Over Limit(dB)
9KHz to 1GHz	RBW=100KHz	-39.99	-13.0	-26.99
1GHz to 10GHz	RBW=1MHz	-26.17	-13.0	-13.17



2.4 For WCDMA mode:

1)lowest frequency:

Measurement Record:				
Frequency range	Measurement bandwidth	Spurious Emission Level(dBm)	Limit(dBm)	Over Limit(dB)
9KHz to 1GHz	RBW=100KHz	-40.15	-13.0	-27.15
1GHz to 10GHz	RBW=1MHz	-25.69	-13.0	-12.69

2)Middle frequency:

Measurement Record:				
Frequency range	Measurement bandwidth	Spurious Emission Level(dBm)	Limit(dBm)	Over Limit(dB)
9KHz to 1GHz	RBW=100KHz	-39.97	-13.0	-26.97
1GHz to 10GHz	RBW=1MHz	-26.31	-13.0	-13.31

3)highest frequency

Measurement Record:				
Frequency range	Measurement bandwidth	Spurious Emission Level(dBm)	Limit(dBm)	Over Limit(dB)
9KHz to 1GHz	RBW=100KHz	-40.25	-13.0	-27.25
1GHz to 10GHz	RBW=1MHz	-26.47	-13.0	-13.47



3. Downlink: 1930MHz ~ 1995MHz

3.1 For LTE mode:

1) lowest frequency

9KHz to 1GHz

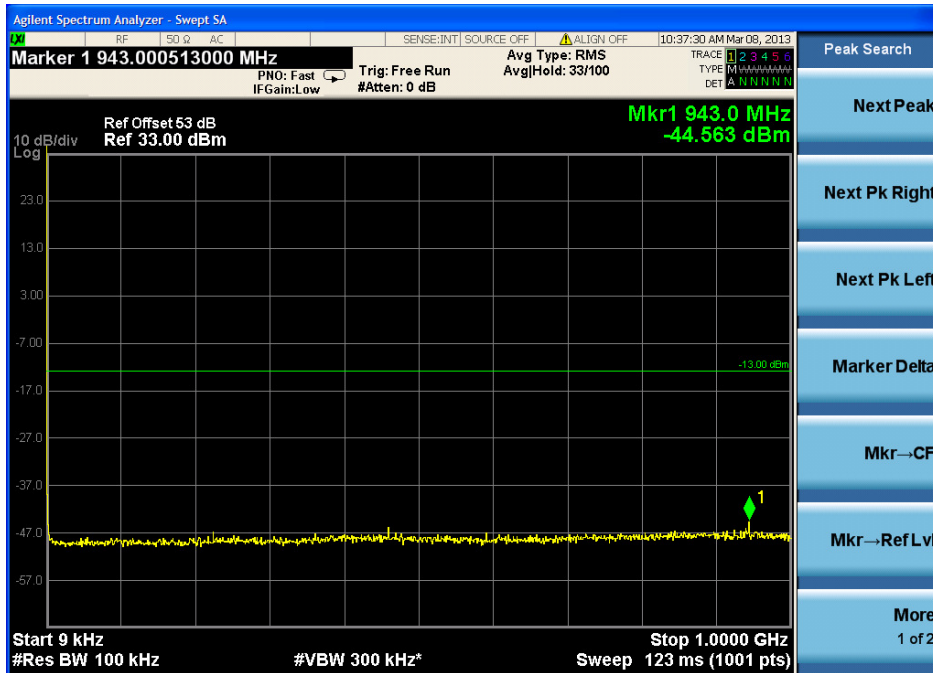

1GHz to 20GHz

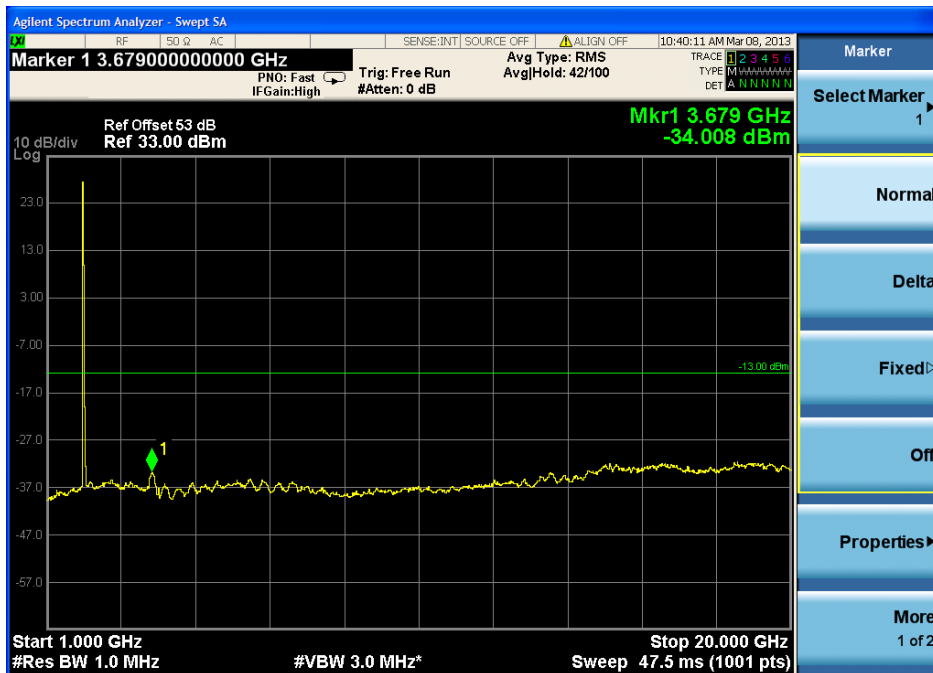



2) Middle frequency

9KHz to 1GHz

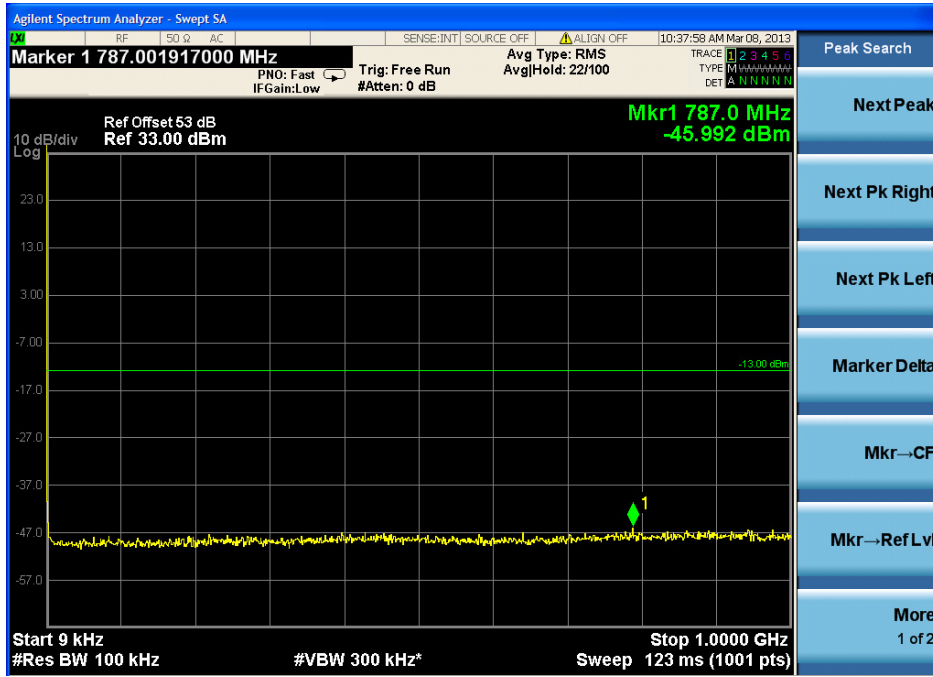

1GHz to 20GHz

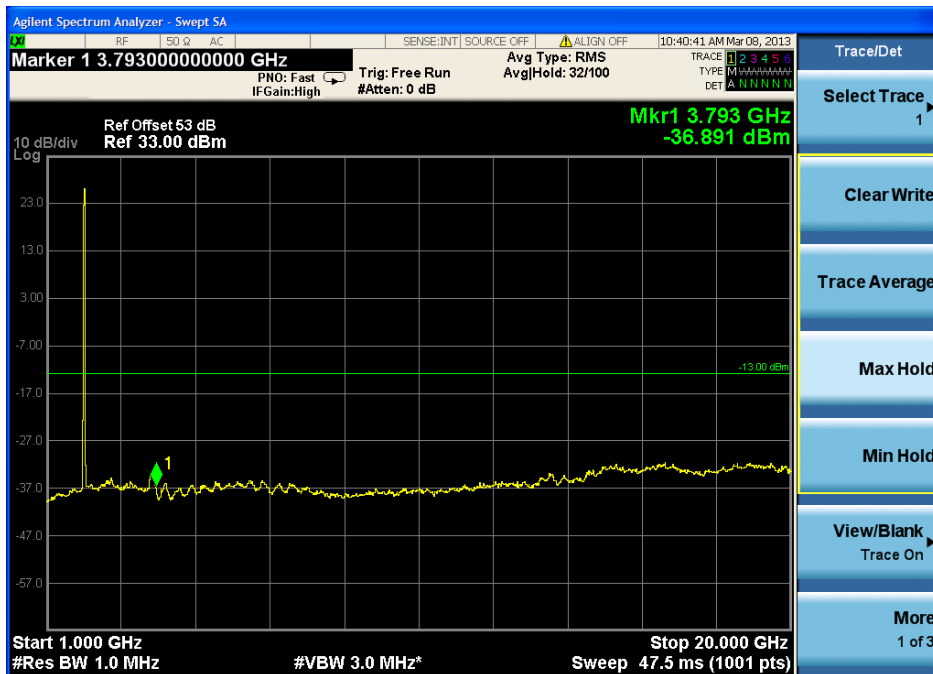



3) highest frequency

9KHz to 1GHz

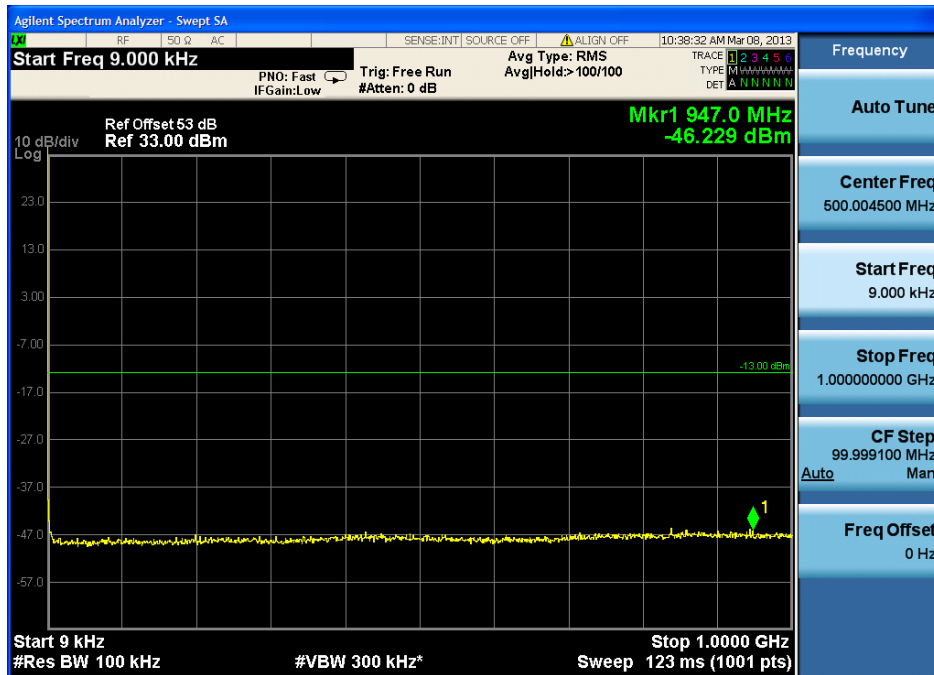

1GHz to 20GHz

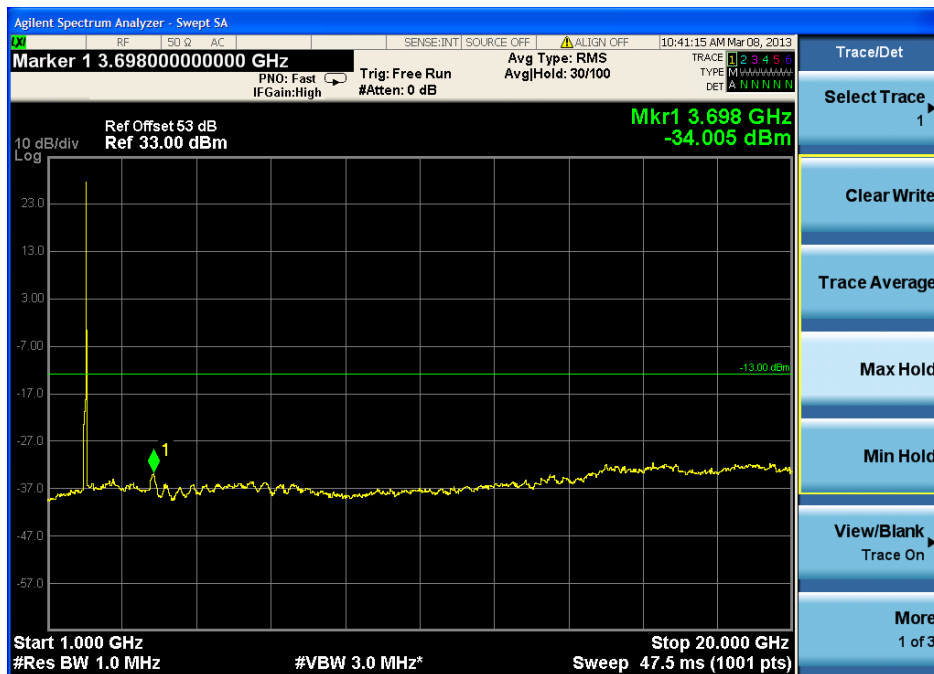



3.2 For GSM mode:

1)lowest frequency:

Measurement Record:				
Frequency range	Measurement bandwidth	Spurious Emission Level(dBm)	Limit(dBm)	Over Limit(dB)
9KHz to 1GHz	RBW=100KHz	-46.12	-13.0	-33.12
1GHz to 20GHz	RBW=1MHz	-35.32	-13.0	-22.32

2)Middle frequency:

Measurement Record:				
Frequency range	Measurement bandwidth	Spurious Emission Level(dBm)	Limit(dBm)	Over Limit(dB)
9KHz to 1GHz	RBW=100KHz	-46.34	-13.0	-33.34
1GHz to 20GHz	RBW=1MHz	-36.79	-13.0	-23.79

3)highest frequency

Measurement Record:				
Frequency range	Measurement bandwidth	Spurious Emission Level(dBm)	Limit(dBm)	Over Limit(dB)
9KHz to 1GHz	RBW=100KHz	-46.48	-13.0	-33.48
1GHz to 20GHz	RBW=1MHz	-35.98	-13.0	-22.98



3.3 For CDMA mode:

1)lowest frequency:

Measurement Record:				
Frequency range	Measurement bandwidth	Spurious Emission Level(dBm)	Limit(dBm)	Over Limit(dB)
9KHz to 1GHz	RBW=100KHz	-46.94	-13.0	-33.94
1GHz to 20GHz	RBW=1MHz	-35.62	-13.0	-22.62

2)Middle frequency:

Measurement Record:				
Frequency range	Measurement bandwidth	Spurious Emission Level(dBm)	Limit(dBm)	Over Limit(dB)
9KHz to 1GHz	RBW=100KHz	-46.48	-13.0	-33.48
1GHz to 20GHz	RBW=1MHz	-35.24	-13.0	-22.24

3)highest frequency

Measurement Record:				
Frequency range	Measurement bandwidth	Spurious Emission Level(dBm)	Limit(dBm)	Over Limit(dB)
9KHz to 1GHz	RBW=100KHz	-46.76	-13.0	-33.76
1GHz to 20GHz	RBW=1MHz	-36.15	-13.0	-23.15



3.4 For WCDMA mode:

1)lowest frequency:

Measurement Record:				
Frequency range	Measurement bandwidth	Spurious Emission Level(dBm)	Limit(dBm)	Over Limit(dB)
9KHz to 1GHz	RBW=100KHz	-46.47	-13.0	-33.47
1GHz to 20GHz	RBW=1MHz	-35.64	-13.0	-22.64

2)Middle frequency:

Measurement Record:				
Frequency range	Measurement bandwidth	Spurious Emission Level(dBm)	Limit(dBm)	Over Limit(dB)
9KHz to 1GHz	RBW=100KHz	-46.98	-13.0	-33.98
1GHz to 20GHz	RBW=1MHz	-36.21	-13.0	-23.21

3)highest frequency

Measurement Record:				
Frequency range	Measurement bandwidth	Spurious Emission Level(dBm)	Limit(dBm)	Over Limit(dB)
9KHz to 1GHz	RBW=100KHz	-46.89	-13.0	-33.89
1GHz to 20GHz	RBW=1MHz	-36.79	-13.0	-23.79



4. Downlink: 2110MHz ~ 2155MHz

4.1 For LTE mode:

1) lowest frequency

9KHz to 1GHz

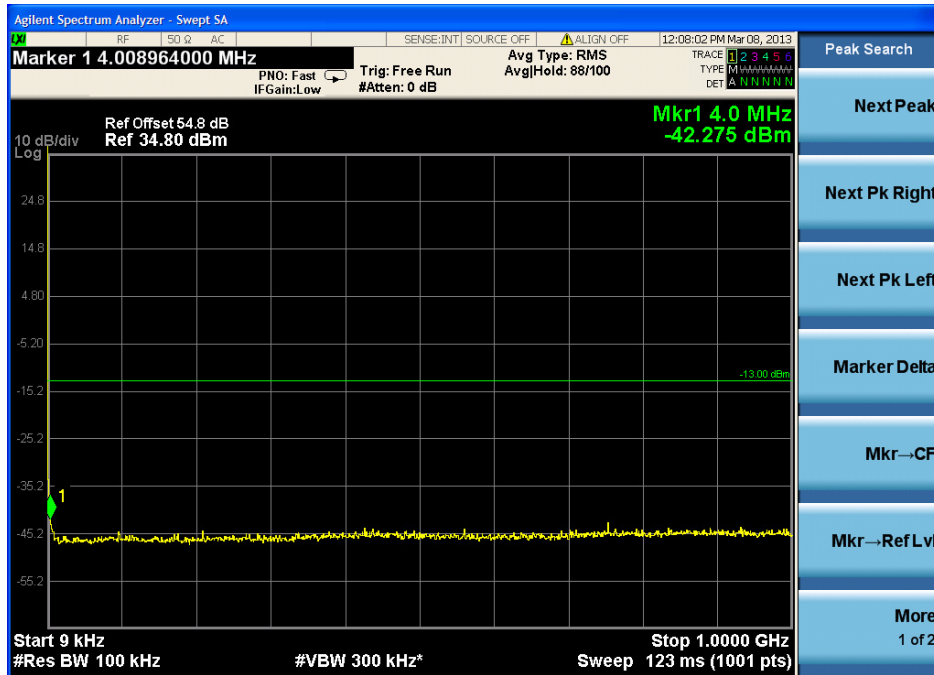

1GHz to 22GHz

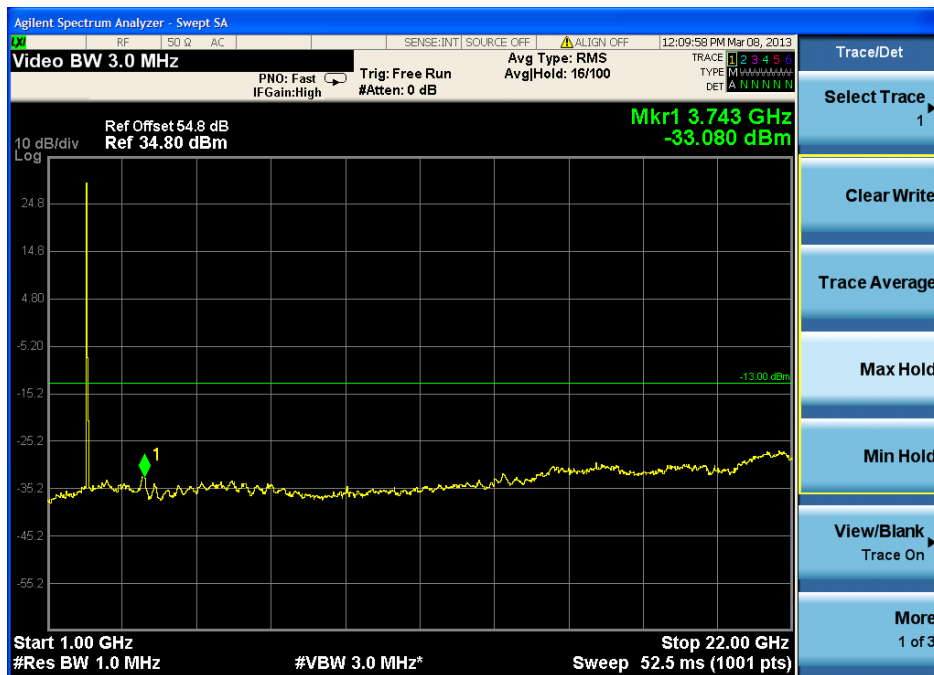



2)Middle frequency

9KHz to 1GHz

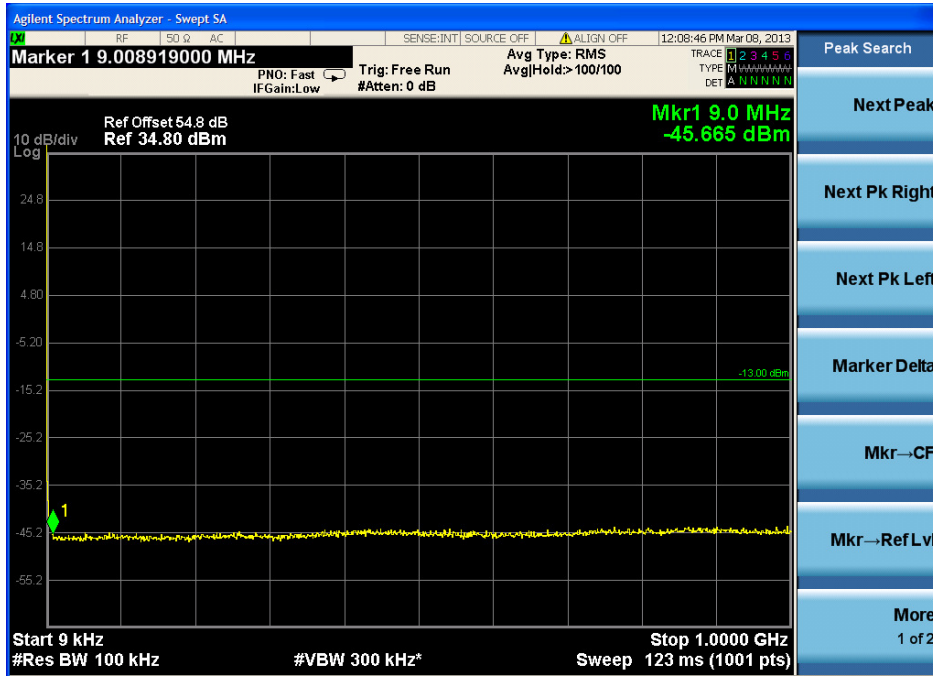

1GHz to 22GHz

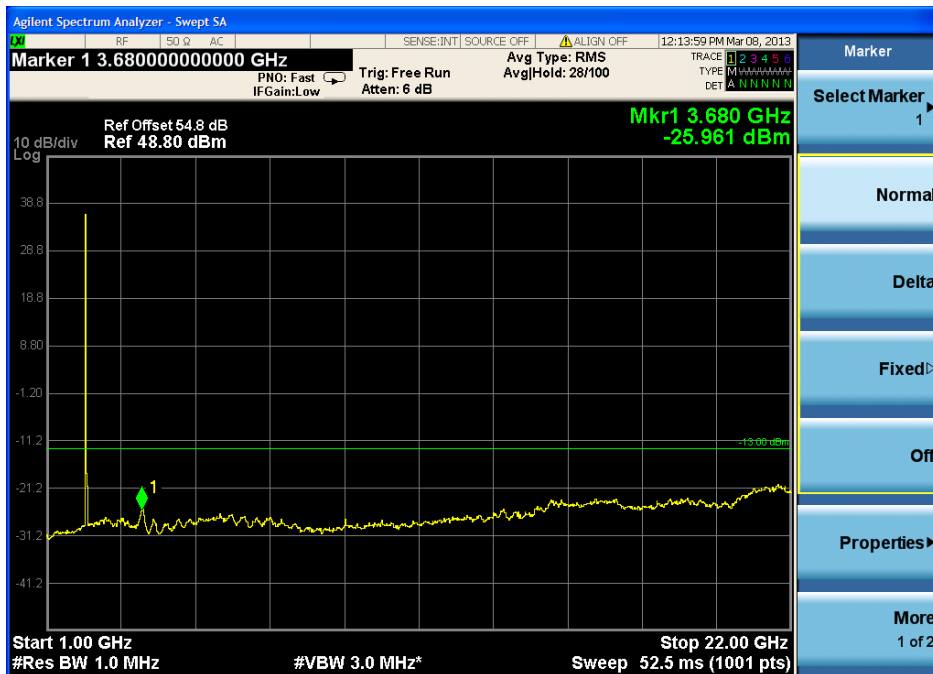



3)highest frequency

9KHz to 1GHz

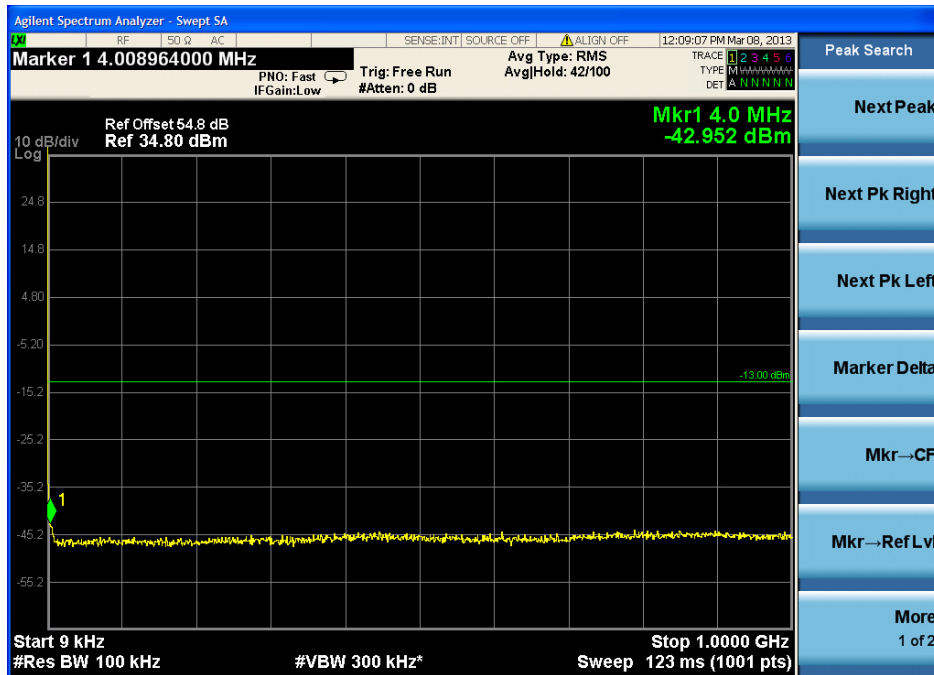

1GHz to 22GHz

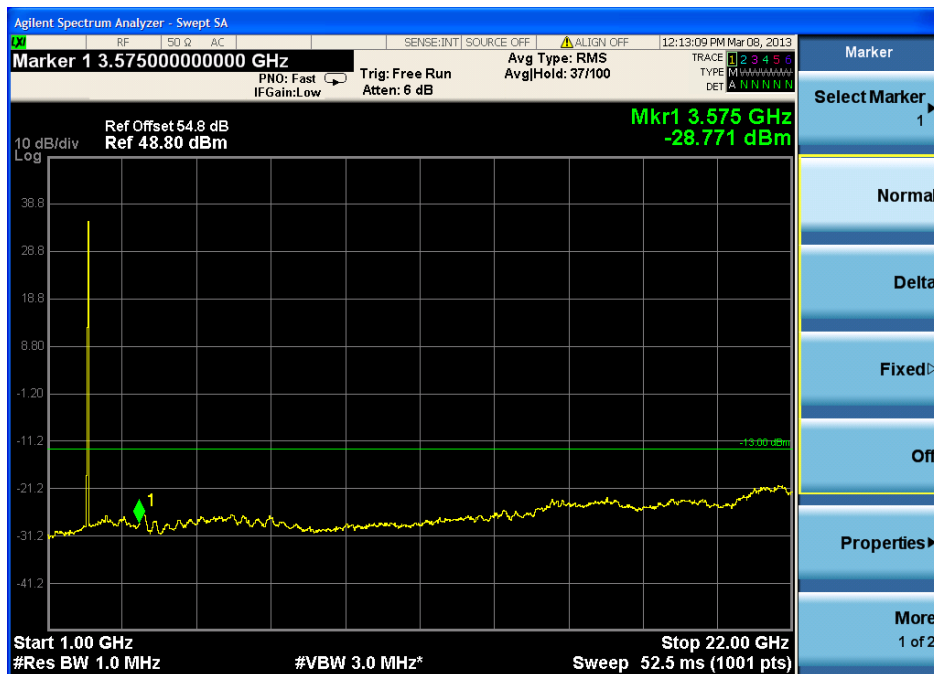



4.2 For CDMA mode:

1)lowest frequency:

Measurement Record:				
Frequency range	Measurement bandwidth	Spurious Emission Level(dBm)	Limit(dBm)	Over Limit(dB)
9KHz to 1GHz	RBW=100KHz	-45.76	-13.0	-32.76
1GHz to 22GHz	RBW=1MHz	-33.45	-13.0	-20.45

2)Middle frequency:

Measurement Record:				
Frequency range	Measurement bandwidth	Spurious Emission Level(dBm)	Limit(dBm)	Over Limit(dB)
9KHz to 1GHz	RBW=100KHz	-46.29	-13.0	-33.29
1GHz to 22GHz	RBW=1MHz	-34.21	-13.0	-21.21

3)highest frequency

Measurement Record:				
Frequency range	Measurement bandwidth	Spurious Emission Level(dBm)	Limit(dBm)	Over Limit(dB)
9KHz to 1GHz	RBW=100KHz	-46.93	-13.0	-33.93
1GHz to 22GHz	RBW=1MHz	-34.18	-13.0	-21.18



4.3 For WCDMA mode:

1)lowest frequency:

Measurement Record:				
Frequency range	Measurement bandwidth	Spurious Emission Level(dBm)	Limit(dBm)	Over Limit(dB)
9KHz to 1GHz	RBW=100KHz	-45.96	-13.0	-32.96
1GHz to 22GHz	RBW=1MHz	-34.52	-13.0	-21.52

2)Middle frequency:

Measurement Record:				
Frequency range	Measurement bandwidth	Spurious Emission Level(dBm)	Limit(dBm)	Over Limit(dB)
9KHz to 1GHz	RBW=100KHz	-46.75	-13.0	-33.75
1GHz to 22GHz	RBW=1MHz	-35.21	-13.0	-22.21

3)highest frequency

Measurement Record:				
Frequency range	Measurement bandwidth	Spurious Emission Level(dBm)	Limit(dBm)	Over Limit(dB)
9KHz to 1GHz	RBW=100KHz	-46.35	-13.0	-33.35
1GHz to 22GHz	RBW=1MHz	-36.34	-13.0	-23.34

7.2.5 Radiated Spurious Emissions

- Test Requirement: RSS-131 clause 6.4
- Test Limit: Spurious emissions of zone enhancers and translators shall be suppressed as much as possible.
 Spurious emissions shall be attenuated below the rated power of the enhancer by at least:
 $43 + 10 \text{ Log } 10 (P \text{ rated in watts})$, or 70 dB, whichever is less stringent.
 (-13dBm is the less stringent value)
- Test Method: RSS-Gen clause 4.9
- EUT Operation:
 Status: Drive the EUT to maximum output power.
 Conditions: Normal conditions
 Application: Enclosure
- Test Configuration:
 9 kHz to 30 MHz emissions:

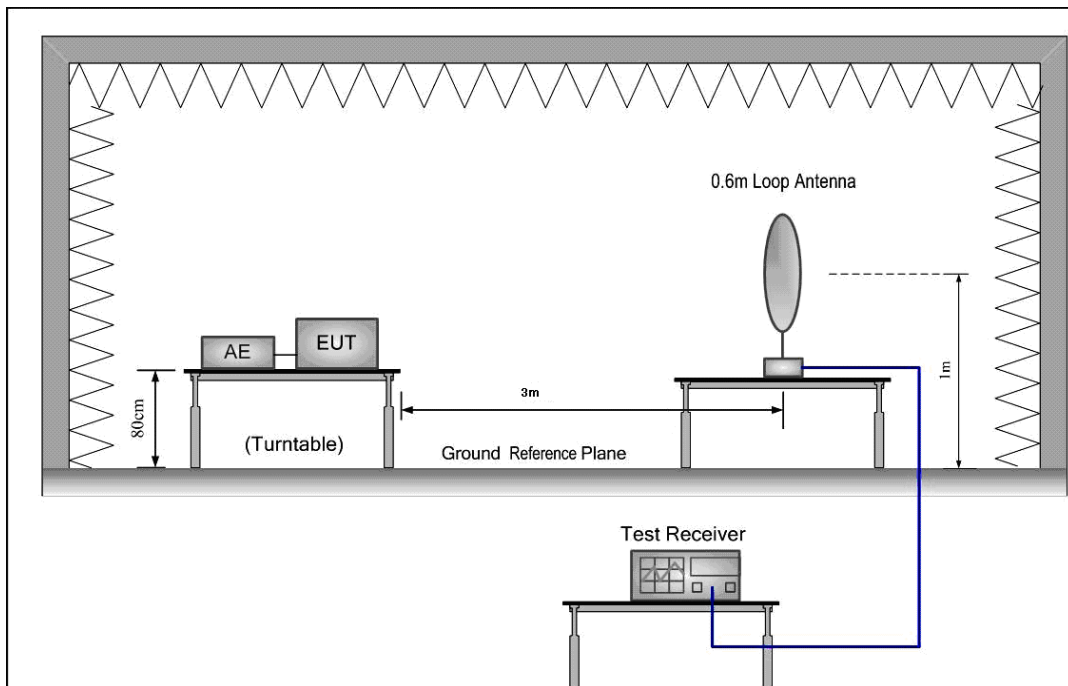

30MHz to 1GHz emissions:

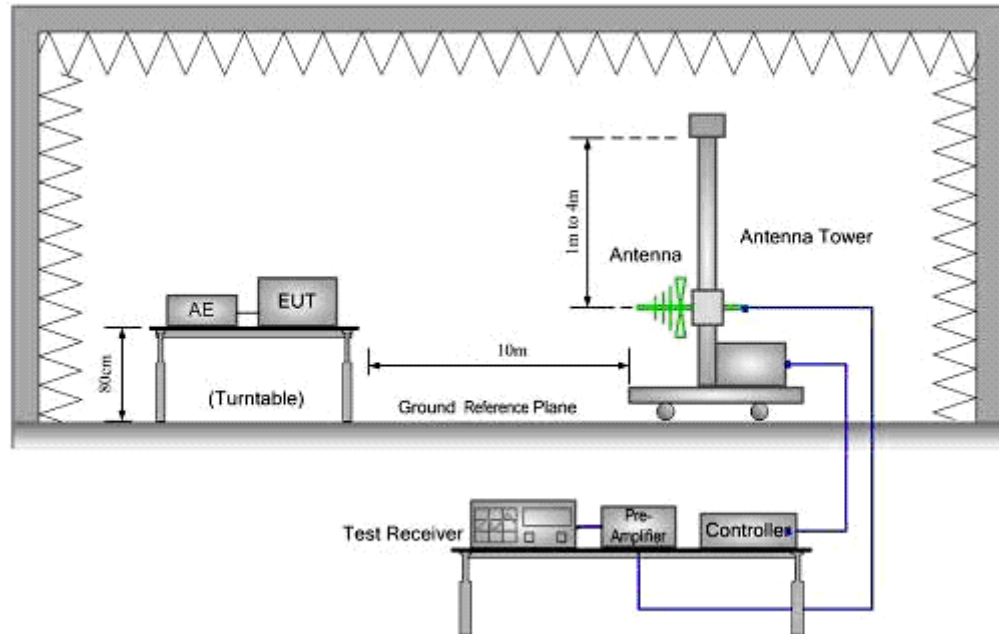

1GHz to 40GHz emissions:

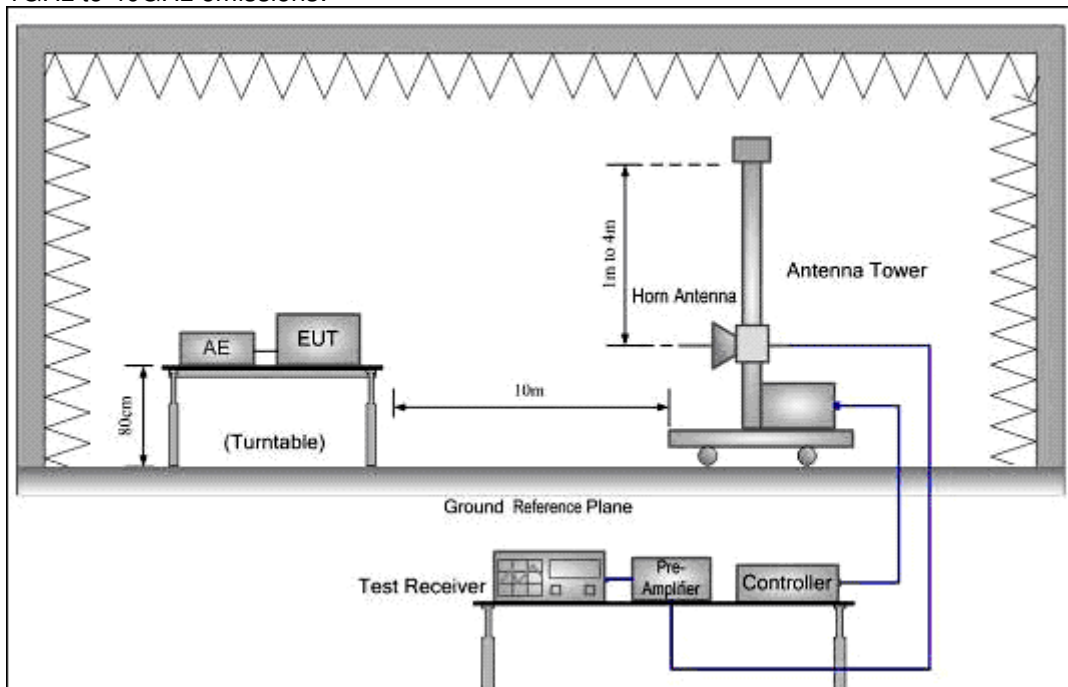

Test Procedure:

1. Test the background noise level with all the test facilities;
2. Keep one transmitting path, all other connectors shall be connected by normal power or RF leads;
3. Select the suitable RF notch filter to avoid the test receiver or spectrum

- analyzer produce unwanted spurious emissions;
4. Keep the EUT continuously transmitting in max power;
 5. Read the radiated emissions of the EUT enclosure.

Radiated Emissions Test Procedure:

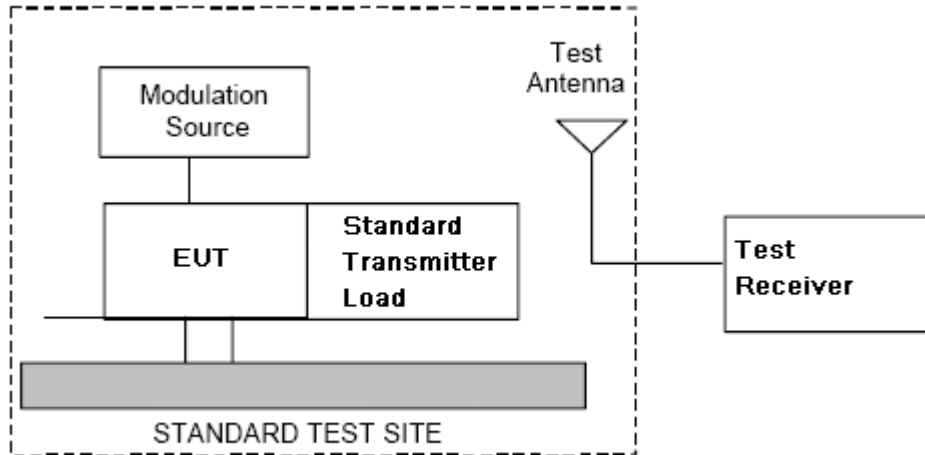

- a) Connect the equipment as illustrated.
- b) Adjust the spectrum analyzer for the following settings:
 - 1) Resolution Bandwidth = 100 kHz for spurious emissions below 1 GHz, and 1 MHz for spurious emissions above 1GHz.
 - 2) Video Bandwidth = 300 kHz for spurious emissions below 1 GHz, and 3 MHz for spurious emissions above 1 GHz.
 - 3) Sweep Speed slow enough to maintain measurement calibration.
 - 4) Detector Mode = Positive Peak.
- c) Place the transmitter to be tested on the turntable in the standard test site, The transmitter is transmitting into a nonradiating load that is placed on the turntable. The RF cable to this load should be of minimum length.
- d) Measurements shall be made from 30MHz to 10 times of fundamental carrier, except for the region close to the carrier equal to \pm the carrier bandwidth.
- e) Key the transmitter without modulation or normal modulation base the standard.
- f) For each spurious frequency, raise and lower the test antenna from 1 m to 4 m to obtain a maximum reading on the spectrum analyzer with the test antenna at horizontal polarity. Then the turntable should be rotated 360° to determine the maximum reading. Repeat this procedure to obtain the highest possible reading. Record this maximum reading.
- g) Repeat step f) for each spurious frequency with the test antenna polarized vertically.

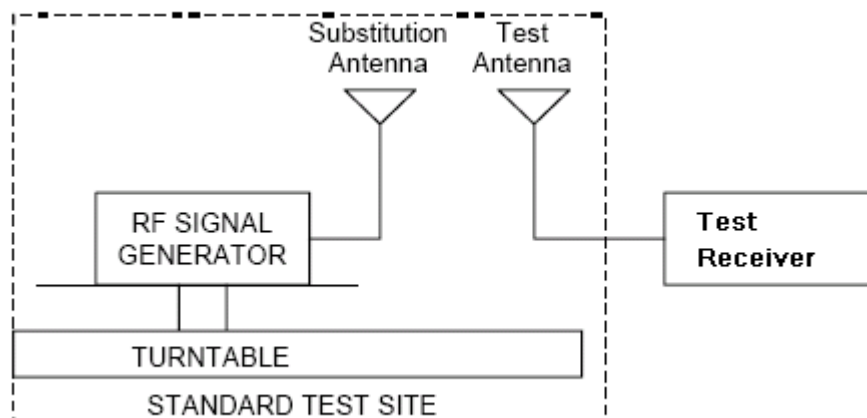



- h) Reconnect the equipment as illustrated.
- i) Keep the spectrum analyzer adjusted as in step b).
- j) Remove the transmitter and replace it with a substitution antenna (the antenna should be half-wavelength for each frequency involved). The center of the substitution antenna should be approximately at the same location as the center of the transmitter. At the lower frequencies, where the substitution antenna is very long, this will be impossible to achieve when the antenna is polarized vertically. In such case the lower end of the antenna should be 0.3 m above the ground.
- k) Feed the substitution antenna at the transmitter end with a signal generator connected to the antenna by means of a nonradiating cable. With the antennas at both ends horizontally polarized, and with the signal generator tuned to a particular spurious frequency, raise and lower the test antenna to obtain a maximum reading at the spectrum analyzer. Adjust the level of the signal generator output until the previously recorded maximum reading for this set of conditions is obtained. This should be done carefully repeating the adjustment of the test antenna and generator output.
- l) Repeat step k) with both antennas vertically polarized for each spurious frequency.
- m) Calculate power in dBm into a reference ideal half-wave dipole antenna by reducing the readings obtained in steps k) and l) by the power loss in the cable between the generator and the antenna, and further corrected for the gain of the substitution antenna used relative to an ideal half-wave dipole

antenna by the following formula:

$$Pd(\text{dBm}) = Pg(\text{dBm}) - \text{cable loss (dB)} + \text{antenna gain (dB)}$$

where:

Pd is the dipole equivalent power and

Pg is the generator output power into the substitution antenna.

NOTE: It is permissible to use other antennas provided they can be referenced to a dipole.

NOTE: Effective radiated power (e.r.p) refers to the radiation of a half wave tuned dipole instead of an isotropic antenna. There is a constant difference of 2.15 dB between e.i.r.p. and e.r.p.

$$\text{e.r.p (dBm)} = \text{e.i.r.p. (dBm)} - 2.15$$



7.2.5.1 Measurement Record:

No emissions were detected within 20dB below the limit for the Downlink direction.

Remark:

The cabinet radiation was measured with the equipment transmitting a CW signal into a non-radiating 50 Ohm load at maximum output power on a signal frequency .

Measured were performed in the lowest, middle and highest frequency for : the Downlink.

The spectrum was searched from 9KHz to 26GHz (10th Harmonic) for downlink;



7.2.6 Frequency Stability of Band Translators

Test Requirement: RSS-131 clause 6.5

Test Limit A band translator is essentially a repeater station and should introduce as little frequency error as possible. The frequency stability should therefore meet the objectives of the overall land mobile or cellular service for which it serves. Better frequency stability than the minimum standard cited below will therefore be required in some cases.

The frequency stability shall be within ± 1.5 parts per million (0.00015%).

Test Method: RSS-Gen clause 4.5

EUT Operation:

Status: Drive the EUT to maximum output power.

Conditions: Temperature conditions, voltage conditions

Application: RF output ports

Test Procedure:

1. Temperature conditions:
 - a) The RF output port of the EUT was connected to Frequency Meter;
 - b) Set the working Frequency in the middle channel;
 - c) record the 20°C and nominal voltage frequency value as reference point;
 - d) vary the temperature from -30°C to 50°C with step 10°C
 - e) when reach a temperature point, keep the temperature balance at least 1 hour to make the product working in this status;
 - f) read the frequency at the relative temperature.
2. Voltage conditions:
 - a) record the 20°C and nominal voltage frequency value as reference point;
 - b) vary the voltage from -15% nominal voltage to +15% voltage;
 - c) read the frequency at the relative voltage.



7.2.6.1 Measurement Record:

1) Frequency Stability vs temperature:

1.1) Test for Downlink: 728~756MHz (middle channel 742MHz)

Temperature(°C)	Frequency(MHz)	Tolerance(ppm)
50	742.000027	0.000404313
40	742.000025	0.000134771
30	742.000023	-0.000134771
20	742.000024	Reference
10	742.000026	0.000269542
0	742.000024	0
-10	742.000027	0.000404313
-20	742.000028	0.000539084
-30	742.000029	0.000673855
-40	742.000026	0.000269542

1.2) Test for Downlink: 869~894MHz (middle channel 881.5MHz)

Temperature(°C)	Frequency(MHz)	Tolerance(ppm)
50	881.500038	0.000794101
40	881.500036	0.000567215
30	881.500034	0.000340329
20	881.500031	Reference
10	881.500028	-0.000340329
0	881.500035	0.000453772
-10	881.500041	0.00113443
-20	881.500032	0.000113443
-30	881.500027	-0.000453772
-40	881.500038	0.000794101

1.3) Test for Downlink: 1930~1995MHz (middle channel 1962.5MHz)

Temperature(°C)	Frequency(MHz)	Tolerance(ppm)
50	1962.500025	-0.000203822
40	1962.500027	-0.000101911
30	1962.500032	0.000152866
20	1962.500029	Reference
10	1962.500043	0.000713376
0	1962.500034	0.000254777
-10	1962.500031	0.000101911
-20	1962.500033	0.000203822
-30	1962.500034	0.000254777
-40	1962.500035	0.000305732

1.4) Test for Downlink: 2110~2155MHz (middle channel 2132.5MHz)

Temperature(°C)	Frequency(MHz)	Tolerance(ppm)
50	2132.5000034	0.0000937867
40	2132.5000032	0.00000
30	2132.5000039	0.000328253
20	2132.5000032	Reference
10	2132.5000029	-0.00014068
0	2132.5000028	-0.000187573
-10	2132.5000035	0.00014068
-20	2132.5000037	0.000234467
-30	2132.5000028	-0.000187573
-40	2132.5000034	0.0000937867

2) Frequency Stability vs voltage:
2.1) For AC supplied:

2.1.1) Test for Downlink:728~757MHz (middle channel 742MHz)

Voltage(V AC)	Frequency(MHz)	Tolerance(ppm)
102 (120*0.85)	742.0000025	0.000134771
120	742.0000024	Reference
138 (120*1.15)	742.0000026	0.000268542

2.1.2) Test for Downlink: 869~894MHz (middle channel 881.5MHz)

Voltage(V AC)	Frequency(MHz)	Tolerance(ppm)
102 (120*0.85)	881.5000032	0.000113443
120	881.5000031	Reference
138 (120*1.15)	881.5000029	-0.000226886

2.1.3) Test for Downlink: 1930~1995MHz (middle channel 1962.5MHz)

Voltage(V AC)	Frequency(MHz)	Tolerance(ppm)
102 (120*0.85)	1962.5000032	0.000152866
120	1962.5000029	Reference
138 (120*1.15)	1962.5000035	0.000305732

2.1.4) Test for Downlink: 2110~2155MHz (middle channel 2132.5MHz)

Voltage(V AC)	Frequency(MHz)	Tolerance(ppm)
102 (120*0.85)	2132.5000033	0.0000468935
120	2132.5000032	Reference
138 (120*1.15)	2132.5000034	0.0000937867



2.2) For DC supplied:

2.2.1) Test for Downlink:728~757MHz (middle channel 742.5MHz)

Voltage(V DC)	Frequency(MHz)	Tolerance(ppm)
-40.8 (-48.0*0.85)	742.000023	-0.000134771
-48.0	742.000024	Reference
-55.2 (-48.0*1.15)	742.000025	0.000134771

2.2.2) Test for Downlink: 869~894MHz (middle channel 881.5MHz)

Voltage(V DC)	Frequency(MHz)	Tolerance(ppm)
-40.8 (-48.0*0.85)	881.500034	0.000340329
-48.0	881.500031	Reference
-55.2 (-48.0*1.15)	881.500028	-0.000340329

2.2.3) Test for Downlink: 1930~1995MHz (middle channel 1962.5MHz)

Voltage(V DC)	Frequency(MHz)	Tolerance(ppm)
-40.8 (-48.0*0.85)	1962.500027	-0.000101911
-48.0	1962.500029	Reference
-55.2 (-48.0*1.15)	1962.500043	0.000713376

2.2.4) Test for Downlink: 2110~2155MHz (middle channel 2132.5MHz)

Voltage(V DC)	Frequency(MHz)	Tolerance(ppm)
-40.8 (-48.0*0.85)	2132.500029	-0.00014068
-48.0	2132.500032	Reference
-55.2 (-48.0*1.15)	2132.500028	-0.000187573

--The End of Report--