

# ONKYO

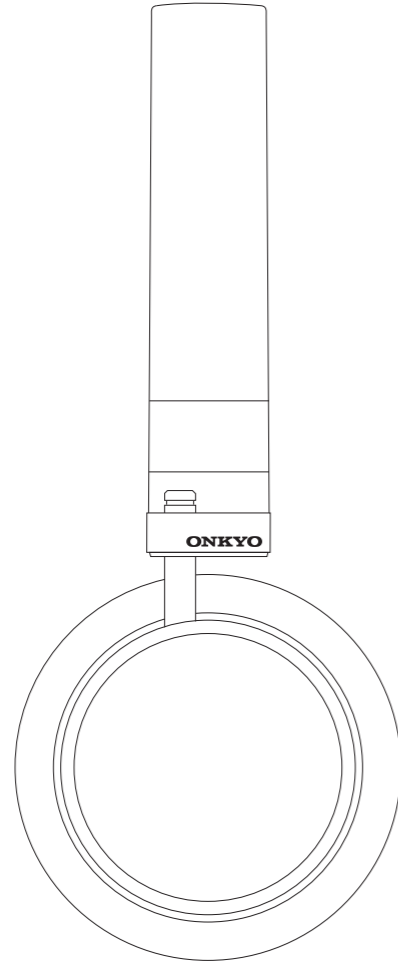

H500BT

QUICK START GUIDE

# ONKYO

www.onkyo.com

2015 © Gibson Innovations Limited. All rights reserved.  
This product has been manufactured by, and is sold under the responsibility of Gibson Innovations Ltd., and Gibson Innovations Ltd. is the warrantor in relation to this product. Gibson Innovations Netherlands B.V. Building

**低功率電波輻射性電機管理辦法**  
第十二條 經型式認證合格之低功率射頻電機，非經許可，公司、商號或使用者均不得擅自變更頻率、加大功率或變更原設計之特性及功能。

第十四條 低功率射頻電機之使用不得影響飛航安全及干擾合法通信；經發現有干擾現象時，應立即停用，並改善至無干擾時方得繼續使用。前項合法通信，指依電信法規定作業之無線電通信。低功率射頻電機須忍受合法通信或工業、科學及醫療用電波輻射性電機設備之干擾。



EN

## Quick start guide

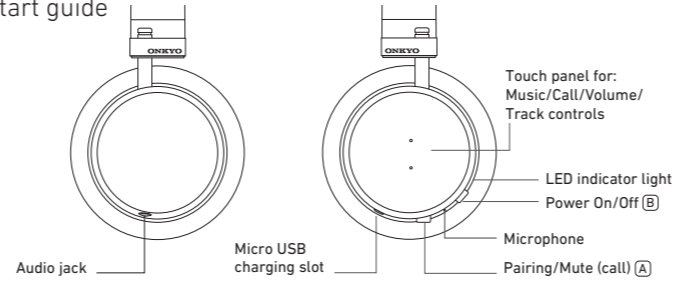

### [ 1.0 Charge the battery ]

1. Plug one end of USB cable into the charger (or into the USB port of a computer).
2. Plug the other end of the cable into the micro USB charging slot on the headset.
3. When the headset is charging, a white indicator light will be displayed.
4. When the headset is fully charged, the white light goes off.

### [ 2.0 Turning the headset on and off ]

1. Turn the headset on. Press and hold (B) for 2 sec.
2. Turn the headset off. Press and hold (B) for 4 sec. A white indicator light turns on for 1.5 sec. and then the headset will turn off.

### [ 3.0 Pair the headset with your phone ]

Pair the headset with your phone manually or by using NFC. After successful pairing, the headset connects automatically to the phone once the headset is turned on and within range.

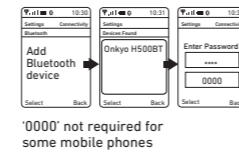

'0000' not required for some mobile phones

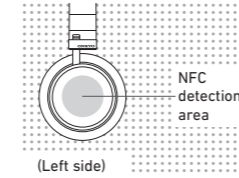

(Left side)

#### Manual Pairing

1. Make sure your headset is turned on.
2. Press and hold (A) until an alternating blue and white light flashes.
3. Turn on the Bluetooth function on your phone.
4. Your phone will start searching for Onkyo H500BT.
5. Follow the on-screen instructions to pair your phone. (Check your phone's user manual for details)

#### NFC Pairing

1. Make sure your headset is turned on.
2. Press and hold (A) until an alternating blue and white light flashes.
3. Make sure you turn on the NFC function on your phone and that your phone's screen remains active.
4. Place your phone over the headset so that the NFC detection area of each device touch each other.
5. Follow the pairing instructions of your phone. If a passcode is required, enter '0000'.

Remarks:

- Make sure your mobile phone has the NFC feature and that the NFC function has been switched on and your phone is not in standby mode.
- Pairing with NFC is suitable only for Android mobile operating system 4.2 or above.

### [ 4.0 Using music and call controls ]

#### MUSIC CONTROLS

Play/Pause	Tap once	
Volume up	Slide up or slide up and hold	
Volume down	Slide down or slide down and hold	
Skip forward	Slide forward	
Skip backward	Slide backward	

#### VOICE/CALL CONTROLS

Siri/Google Now*	Press once	
Pick up call/Hang up	Tap once	
Reject incoming call	Tap and hold	
Mute/unmute the mic while in a call	Press once	
Switch caller while in a call	Slide forward	

\* To use the voice control feature on your phone via Bluetooth please refer to the user manual for the correct settings for your device.

### [ 5.0 LED Indicator light ]

A white light flashes slowly.	The battery is low.
An alternating white and blue light flashes.	The headset is in pairing mode.
A blue light flashes at every 8 seconds interval.	The headset is both paired & connected.
A blue light flashes rapidly.	The headset is switched on but not connected. If no connection can be made, the headset will turn itself off after 5 minutes.

### [ 6.0 Corded audio connection ]

You can also use this headset with the audio cable provided when the battery is low. Make sure the headset is turned off before using the audio cable.

### [ 7.0 Multipoint ]

#### Pairing additional devices

A total of 4 bluetooth devices can be paired with your headphones. (See step 3 for pairing). Two devices can be connected simultaneously allowing you to switch between them both.

#### Switching between devices

The multipoint feature allows you to connect and switch between two devices simultaneously. Simply pause your music or video on one device and press play on your second device, the headphone will automatically connect to the playing device. When you receive a phone call the audio on the first device automatically pauses to receive the phone call on the second device, with the audio resuming when the call has finished. (See step 4 for call controls)

Please refer to www.onkyo.com/welcome for the full user manual