



Hong Kong

FCC / IC – Test report

Report Number : **60/790.15.003.01** Date of Issue: March 2, 2015

Model : **BT2000B/37, BT2000A/37, BT2000R/37, BT2000L/37**

Brand : **PHILIPS**

Product Type : **Wireless Portable Speakers**

Applicant : **WOOX Innovations Limited**

Address : **5/F, Philips Electronics Building, 5 Science Park East Avenue, Hong Kong Science Park, Shatin, New Territories, Hong Kong**

Production Facility : **WOOX Innovations Limited**

Address : **5/F, Philips Electronics Building, 5 Science Park East Avenue, Hong Kong Science Park, Shatin, New Territories, Hong Kong**

Test Result : **Positive** **Negative**

Total pages including Appendices : **57**

TÜV SÜD Hong Kong Ltd. is a subcontractor to TÜV Product Service, GmbH according to the principles outlined in ISO 17025.

TÜV SÜD Hong Kong Ltd. reports apply only to the specific samples tested under stated test conditions. Construction of the actual test samples has been documented. It is the manufacturer's responsibility to assure that additional production units of this model are manufactured with identical electrical and mechanical components. The manufacturer/importer is responsible to the Competent Authorities in Europe for any modifications made to the production units which result in non-compliance to the relevant regulations. TÜV SÜD Hong Kong Ltd. shall have no liability for any deductions, inferences or generalizations drawn by the client or others from TÜV SÜD Hong Kong Ltd. issued reports.

This report is the confidential property of the client. As a mutual protection to our clients, the public and ourselves, extracts from the test report shall not be reproduced except in full without our written approval.

Report Number: **60/790.15.003.01**

TÜV SÜD HONG KONG LTD., 3/F, West Wing, Lakeside 2, 10 Science Park West Avenue, Science Park, Shatin, HK.
Tel: +852-2776 1323 Fax: +852-2776 1206

Page 1 of 57

Rev. no.: 2.1



1. Table of Contents

- 1. Table of Contents2
- 2. Details about the Test Laboratory.....4
- 3. Description of the Equipment Under Test5
- 4. Summary of Test Standards6
- 5. Mode of Operation.....6
- 6. Assistant Equipment Used in Test6
- 7. Summary of Test Standards and Results7
- 8. General Remarks8
- 9. Test Results9
 - 9.1 Maximum Conducted Output Power Measurement9
 - Limit9
 - Test Setup9
 - Test Instruments9
 - Test Procedure9
 - Test Result10
 - 9.2 Conducted Emission Measurement.....12
 - Limit12
 - Test Instruments12
 - Test Setup12
 - Test Procedure13
 - Test Result14
 - 9.3 Radiated Interference Measurement16
 - Limit16
 - Test Instruments16
 - Setup17
 - Test Procedure18
 - Test Result19
 - 9.4 20dB Bandwidth & 99% OBW Measurement21
 - Limit21
 - Test Setup21
 - Test Instruments21
 - Test Procedure21
 - Test Result23
 - Test Graphs.....24
 - 9.5 Carrier Frequency Separation Measurement26



Limit26

Test Setup26

Test Instruments26

Test Procedure26

Test Result27

Test Graphs.....28

9.6 Number of Hopping Measurement29

Limit29

Test Setup29

Test Instruments29

Test Procedure29

Test Result30

Test Graphs.....31

9.7 Time of Occupancy (Dwell Time) Measurement33

Limit33

Test Setup33

Test Instruments33

Test Procedure33

Test Result34

Test Graphs.....36

9.8 Out of Band Conducted Emissions Measurement42

Limit42

Test Setup42

Test Instruments42

Test Procedure42

Test Graphs.....43

9.9 Band Edges Measurement52

Limit52

Test Setup52

Test Instruments52

Test Procedure53

Test Result54

9.10 Antenna Measurement57

Limit57

Antenna Connector Construction.....57



2. Details about the Test Laboratory

Details about the Test Laboratory

Test site 1

Company name: TÜV SÜD HONG KONG LTD.
3/F, West Wing, Lakeside 2,
10 Science Park West Avenue,
Science Park, Shatin
HK.

Telephone: 852 2776 1323
Fax: 852 2776 1372

Test site 2

Company name: A Test Lab Techno Corp.
No.140-1. Changan Street, Bady City,
Taoyuan County 334, Taiwan
FCC Test Firm Registration Number:510205
IC Assigned Code: 7381A

Test site 3

Company name: STC(Dongguan) Company Ltd.
68 Fumin Nan Rd, Dalang, Dongguan, Guangdong, PRC
FCC Test Firm Registration Number: 629686
IC Assigned Code: 4789B

Test site 4

Company name: Shenzhen Zhongjian Nanfang Testing Co.,Ltd
1st Floor, Block No.2, Laodong Industrial Zone,
Xixiang Road Baoan District, Shenzhen, China
FCC Test Firm Registration Number: 817957
IC Assigned Code: 10106A



3. Description of the Equipment Under Test

Description of the Equipment Under Test

Product:	Wireless Portable Speakers
Model no.:	BT2000B/37
Serial number:	NIL
Options and accessories:	NIL
FCC ID:	2AANUBT2000
IC:	11260A-BT2000
Rated Voltage:	3.7 VDC
Frequency:	2402-2480MHz
RF Transmission Frequency:	2402-2480MHz
Antenna gain:	0 dBi
No. of Operated Channel:	79
Modulation:	GFSK, pi/4-DQPSK, 8DPSK
Description of the EUT:	Battery operated –Internal rechargeable battery
Charging Rate:	DC 5V

4. Summary of Test Standards

Test Standards	
FCC Part 15 Subpart C, Intentional Radiators, 10-1-12 Edition	PART 15 – RADIO FREQUENCY DEVICES Subpart C – Intentional Radiators
RSS-Gen Issue 4 December 2014	General Requirements for Compliance of Radio Apparatus
RSS-210 Issue 8 December 2010	RSS-210 — Licence-exempt Radio Apparatus (All Frequency Bands): Category I Equipment

5. Mode of Operation

All the test modes were carried out with the EUT in normal operation, which was shown in this test report and defined as:

Mode
Mode 1: GFSK Link Mode
Mode 2: pi/4-QPSK Link Mode
Mode 3: 8DPSK Link Mode
--

By preliminary testing and verifying three axis (X, Y and Z) position of EUT transmitted status, it was found that “Y axis” position was the worst, then the final test was executed the worst condition and test data were recorded in this report.

6. Assistant Equipment Used in Test

Assistant Equipment: Adapter for charging
Model: DSA-5PFK-05
Brand :PCD
Input: AC100-240V 50/60Hz 0.2A
Output: DC 5V, 1A

7. Summary of Test Standards and Results

Emission Tests					
Test Condition	Pages	Test site	Test Result		
			Pass	Fail	N/A
Maximum Conducted Output Power	9	Site 2	<input checked="" type="checkbox"/>	<input type="checkbox"/>	<input type="checkbox"/>
Conducted Emission Measurement	12	Site 3	<input checked="" type="checkbox"/>	<input type="checkbox"/>	<input type="checkbox"/>
Radiated Interference Measurement Bellow 1GHz	16	Site 3	<input checked="" type="checkbox"/>	<input type="checkbox"/>	<input type="checkbox"/>
Radiated Interference Measurement Above 1GHz	16	Site 4	<input checked="" type="checkbox"/>	<input type="checkbox"/>	<input type="checkbox"/>
20dB down and 99% Bandwidth	21	Site 2	<input checked="" type="checkbox"/>	<input type="checkbox"/>	<input type="checkbox"/>
Carrier Frequency Separation	26	Site 2	<input checked="" type="checkbox"/>	<input type="checkbox"/>	<input type="checkbox"/>
Number of Hopping	29	Site 2	<input checked="" type="checkbox"/>	<input type="checkbox"/>	<input type="checkbox"/>
Time of Occupancy (Dwell Time)	33	Site 2	<input checked="" type="checkbox"/>	<input type="checkbox"/>	<input type="checkbox"/>
Out of Band Conducted Spurious Emission	42	Site 2	<input checked="" type="checkbox"/>	<input type="checkbox"/>	<input type="checkbox"/>
Conducted Band Edge Measurement	52	Site 2	<input checked="" type="checkbox"/>	<input type="checkbox"/>	<input type="checkbox"/>
Radiated Band Edge Measurement	52	Site 4	<input checked="" type="checkbox"/>	<input type="checkbox"/>	<input type="checkbox"/>
Antenna Requirement	57	Site 2	<input checked="" type="checkbox"/>	<input type="checkbox"/>	<input type="checkbox"/>

8. General Remarks

Remarks

This submittal(s) (test report) is intended for FCC ID: 2AANUBT2000 complies with the FCC Part 15, Subpart C Rules.

This submittal(s) (test report) is intended for IC ID: 11260A-BT2000 complies with the RSS-Gen and RSS-210 Rules.

All the configurations of the product were tested and only the worst test results are listed in the report.

SUMMARY:

All tests according to the regulations cited on page 7 were

- Performed
- **Not** Performed

The Equipment Under Test

- **Fulfills** the general approval requirements.
- **Does not** fulfill the general approval requirements.

Sample Received Date: February 5, 2015

Testing Start Date: February 9, 2015

Testing End Date: February 17, 2015

- TÜV SÜD HONG KONG LTD. -

Reviewed by:

Edmond FUNG



Prepared by:



CHAN Kwong Ngai

9. Test Results

9.1 Maximum Conducted Output Power Measurement Limit

For frequency hopping systems operating in the 2400–2483.5 MHz band employing at least 75 non-overlapping hopping channels < 1 watt.

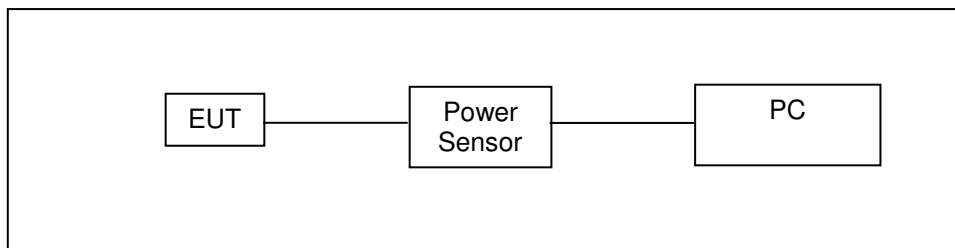
Test Setup



Test Instruments

Equipment	Manufacturer	Model Number	Serial Number	Cal. Date	Remark
Power Sensor	Agilent	U2021XA	MY53180015	05/24/2014	(1)
USB Modular Simultaneous Data Acquisition	Agilent	U2531A	TW53353509	N.C.R.	
RF cable	WOKEN	--	S02-140428-049	07/14/2014	(1)

Remark: (1) Calibration period 1 year. (2) Calibration period 2 years.

NOTE: N.C.R. = No Calibration Request.

Test Procedure

Testing must be done according to this procedure, FCC Public Notice DA 00-705 - Filing and Measurement Guidelines for Frequency Hopping Spread Spectrum Systems. This is the only method recognized by the FCC. The tests below are run with the EUT's transmitter set at high power in TX mode. The EUT is needed to force selection of output power level and channel number. While testing, EUT was set to transmit continuously. Remove the Subjective device's antenna and connect the RF output port to power sensor. The maximum peak output power shall not exceed 1 watt.

Use a direct connection between the antenna port of transmitter and the power sensor, for prevent the power sensor input attenuation 40-50 dB. Set the RBW Bandwidth of the emission or use a channel power meter mode.

For antennas with gains of 6 dBi or less, maximum allowed transmitter output is 1 watt (+30 dBm). For antennas with gains greater than 6 dBi, transmitter output level must be decreased by an amount equal to (GAIN - 6)/3 dBm.

The antenna port of the EUT was connected to the input of a power sensor. Power was read directly and cable loss correction was added to the reading to obtain power at the EUT antenna terminals.

Test Result

Model Number	BT2000B/37			
Test Item	Maximum Conducted Output Power			
Test Mode	Mode 1: GFSK Link Mode			
Date of Test	2015/02/15			
Frequency (MHz)	Packet Type	Peak Power		Limit (mW)
		(dBm)	(mW)	
2402	DH1	-0.921	0.809	< 1000
	DH3	-0.925	0.808	
	DH5	-0.931	0.807	
2441	DH1	-1.993	0.632	
	DH3	-1.991	0.632	
	DH5	-1.987	0.633	
2480	DH1	-3.275	0.470	
	DH3	-3.278	0.470	
	DH5	-3.269	0.471	

Note: The relevant measured result has the offset with cable loss already.

Model Number	BT2000B/37			
Test Item	Maximum Conducted Output Power			
Test Mode	Mode 2: pi/4-QPSK Link Mode			
Date of Test	2015/02/15			
Frequency (MHz)	Packet Type	Peak Power		Limit (mW)
		(dBm)	(mW)	
2402	DH1	0.252	1.060	< 1000
	DH3	0.261	1.062	
	DH5	0.262	1.062	
2441	DH1	-0.784	0.835	
	DH3	-0.767	0.838	
	DH5	-0.755	0.840	
2480	DH1	-2.122	0.613	
	DH3	-2.097	0.617	
	DH5	-2.083	0.619	

Note: The relevant measured result has the offset with cable loss already.

Model Number	BT2000B/37			
Test Item	Maximum Conducted Output Power			
Test Mode	Mode 3: 8DPSK Link Mode			
Date of Test	2015/02/15			
Frequency (MHz)	Packet Type	Peak Power		Limit (mW)
		(dBm)	(mW)	
2402	DH1	0.266	1.063	< 1000
	DH3	0.268	1.064	
	DH5	0.264	1.063	
2441	DH1	-0.756	0.840	
	DH3	-0.739	0.844	
	DH5	-0.747	0.842	
2480	DH1	-2.063	0.622	
	DH3	-2.058	0.623	
	DH5	-2.054	0.623	

Note: The relevant measured result has the offset with cable loss already.

9.2 Conducted Emission Measurement Limit

Frequency (MHz)	Quasi-peak	Average
0.15 - 0.5	66 to 56	56 to 46
0.50 - 5.0	56	46
5.0 - 30.0	60	50

Test Instruments

Describe	Manufacturer	Model Number	Serial Number	Cal. Date	Remark
Test Receiver	R&S	ESCI30	SB3319	01/20/2015	(1)
LISN	R&S	ENV216	SB4357	01/20/2015	(1)

Remark: (1) Calibration period 1 year. (2) Calibration period 2 years.

NOTE: N.C.R. = No Calibration Request.

Test Setup

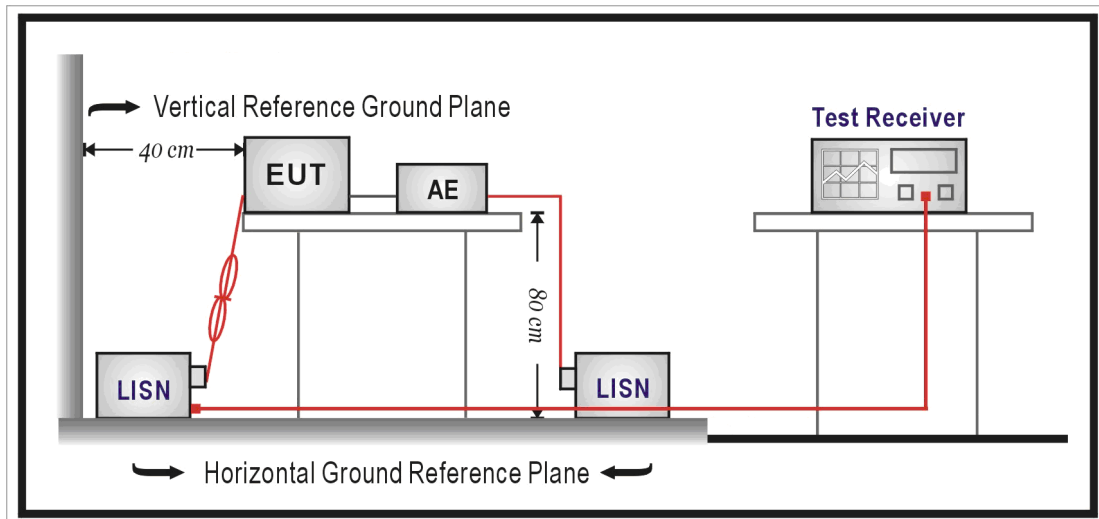



Test Procedure

The power line conducted emission measurements were performed in a shielded enclosure. The EUT was assembled on a wooden table which is 80 centimeters high, was placed 40 centimeters from the back wall and at least 1 meter from the sidewall.

Power was fed to the EUT from the public utility power grid through a line filter and EMCO Model 3162/2 SH Line Impedance Stabilization Networks (LISN). The LISN housing, measuring instrumentation case, ground plane, etc., were electrically bonded together at the same RF potential. The Spectrum analyzer was connected to the AC line through an isolation transformer. The 50-ohm output of the LISN was connected to the spectrum analyzer directly. Conducted emission levels were in the CISPR quasi-peak detection mode. The analyzer's 6 dB bandwidth was set to 9 KHz. No post-detector video filter was used.

The spectrum was scanned from 150 KHz to 30 MHz. The physical arrangement of the test system and associated cabling was varied (within the scope of arrangements likely to be encountered in actual use) to determine the effect on the unit's emanations in amplitude and frequency. All spurious emission frequencies were observed. The highest emission amplitudes relative to the appropriate limit were measured and have been recorded in paragraph 4.1.

Test Result

Standard:	FCC Part 15C	Line:	L1
Test item:	Conducted Emission	Power:	AC 120V/60Hz
Model Number:	BT2000B/37	Temp.(°C)/Hum.(%RH):	26(°C)/60%RH
Mode:	Mode 1	Date:	2015/02/12
Description: Line			

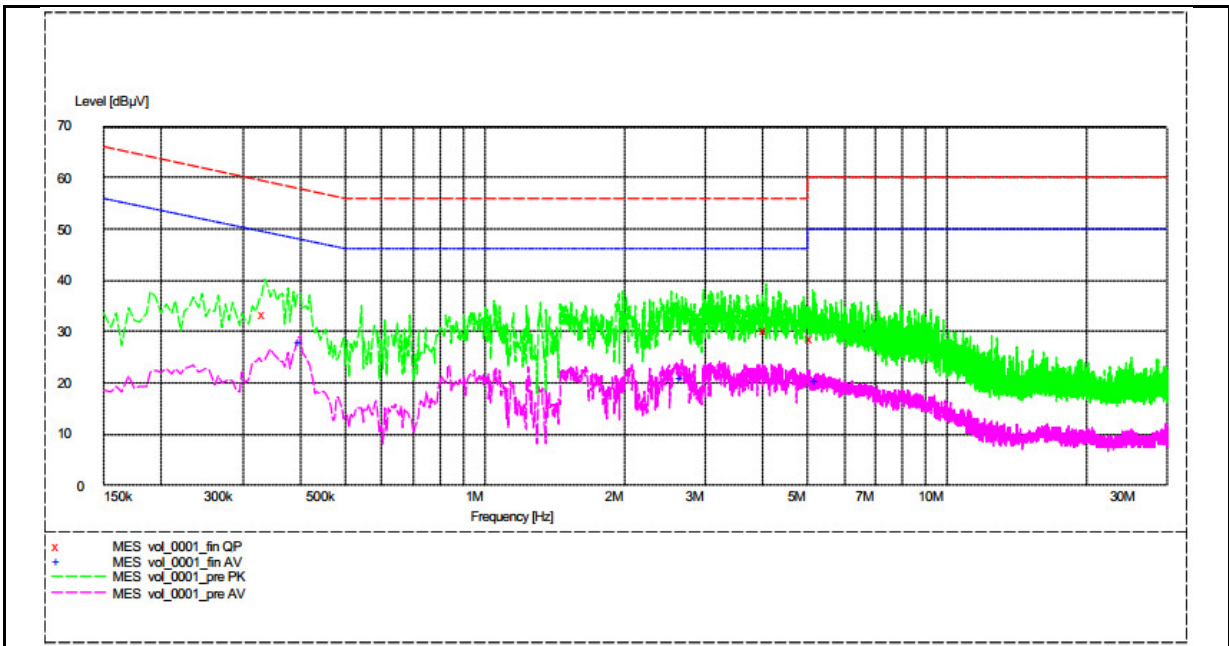

MEASUREMENT RESULT: "vol_0001_fin AV"

6/14/2014 11:16AM

Frequency MHz	Level dBµV	Transd dB	Limit dBµV	Margin dB	Line	PE
0.400000	27.80	9.6	48	20.1	N	GND
2.685000	20.80	9.7	46	25.2	N	GND
5.240000	20.40	9.7	50	29.6	N	GND

MEASUREMENT RESULT: "vol_0001_fin QP"

6/14/2014 11:16AM

Frequency MHz	Level dBµV	Transd dB	Limit dBµV	Margin dB	Line	PE
0.335000	33.50	9.6	59	25.8	N	GND
4.060000	30.40	9.7	56	25.6	N	GND
5.155000	28.50	9.7	60	31.5	N	GND

Standard:	FCC Part 15C	Line:	N
Test item:	Conducted Emission	Power:	AC 120V/60Hz
Model Number:	BT2000B/37	Temp.(°C)/Hum.(%RH):	26(°C)/60%RH
Mode:	Mode 1	Date:	2015/02/12
Description: Neutral			

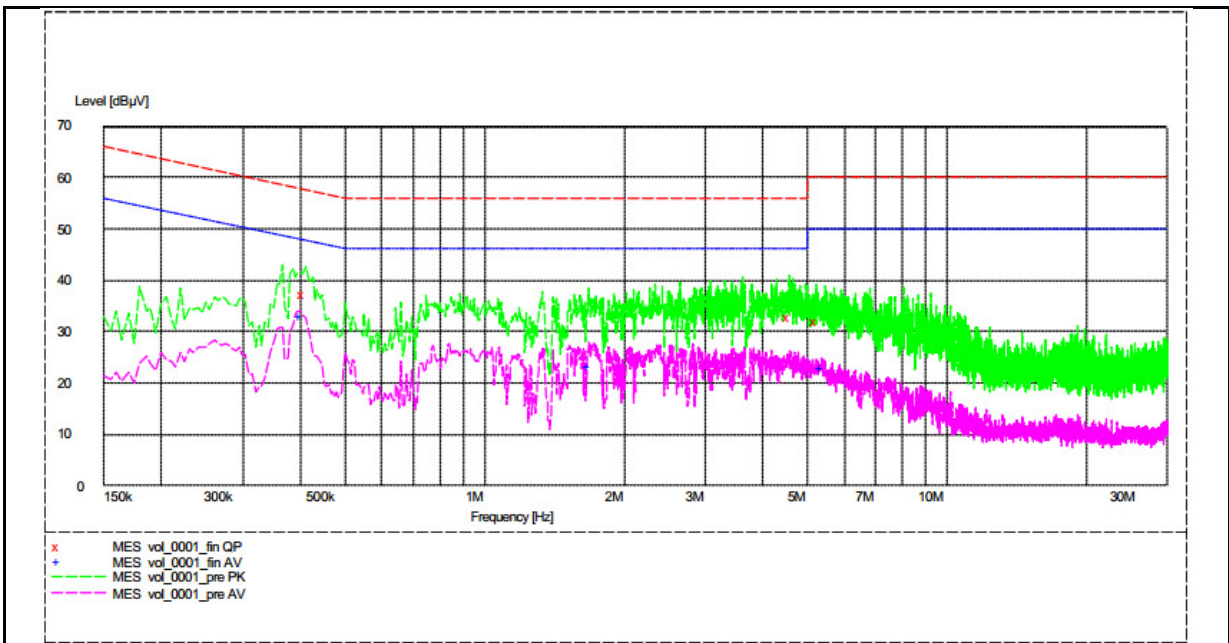

MEASUREMENT RESULT: "vol_0001_fin AV"

6/14/2014 11:13AM

Frequency MHz	Level dBµV	Transd dB	Limit dBµV	Margin dB	Line	PE
0.400000	32.90	9.6	48	15.0	L1	GND
1.685000	23.10	9.7	46	22.9	L1	GND
5.375000	22.60	9.7	50	27.4	L1	GND

MEASUREMENT RESULT: "vol_0001_fin QP"

6/14/2014 11:13AM

Frequency MHz	Level dBµV	Transd dB	Limit dBµV	Margin dB	Line	PE
0.410000	37.50	9.6	58	20.1	L1	GND
4.555000	33.00	9.7	56	23.0	L1	GND
5.245000	32.10	9.7	60	27.9	L1	GND

9.3 Radiated Interference Measurement Limit

According to §15.209(a), except as provided elsewhere in this subpart, the emissions from an intentional radiator shall not exceed the field strength levels specified in the following table:

Frequency (MHz)	Field Strength ($\mu\text{V/m}$ at meter)	Measurement Distance (meters)
0.009 – 0.490	2400 / F (kHz)	300
0.490 – 1.705	24000 / F (kHz)	30
1.705 – 30.0	30	30
30 - 88	100**	3
88-216	150**	3
216-960	200**	3
Above 960	500	3

** Except as provided in paragraph (g), fundamental emissions from intentional radiators operating under this Section shall not be located in the frequency bands 54-72 MHz, 76-88 MHz, 174-216 MHz or 470-806 MHz. However, operation within these frequency bands is permitted under other sections of this Part, e.g., Sections 15.231 and 15.241.

Test Instruments

3 Meter Chamber					
Equipment	Manufacturer	Model Number	Serial Number	Cal. Date	Remark
EMI Test Receiver	R&S	ESU40	SB8501/09	05/16/2014	(1)
Bilog Antenna	SCHWARZBECK	VULB9163	SB8501/04	01/20/2015	(1)
Horn Antenna	R&S	HF906	SB3435	01/20/2015	(1)
3-dimensional loop antenna	SCHWARZBECK	HXYZ9170	9124	01/20/2015	(1)
Amplifier(1-18GHz)	R&S	--	SB3435/01	01/20/2015	(1)
Amplifier(18-40GHz)	R&S	--	SB3435/02	01/20/2015	(1)
Horn Antenna	Amplifier Research	AT4560	SB5392/02	05/16/2014	(1)
RF cable(0.4m)	Woken	/	S02-1404-09-065	05/11/2014	(1)
RF cable(3.5m)	Woken	/	S02-1404-09-047	05/11/2014	(1)
RF cable(1.2m)	Woken	/	S02-1404-09-052	05/11/2014	(1)
3m Semi-anechoic chamber	Albatross Projects	9X6X6	SB3450/01	10/12/2014	(1)

Remark: (1) Calibration period 1 year. (2) Calibration period 2 years. (3) Calibration period 3 years.

NOTE: N.C.R. = No Calibration Request.

Setup

9KHz-30MHz

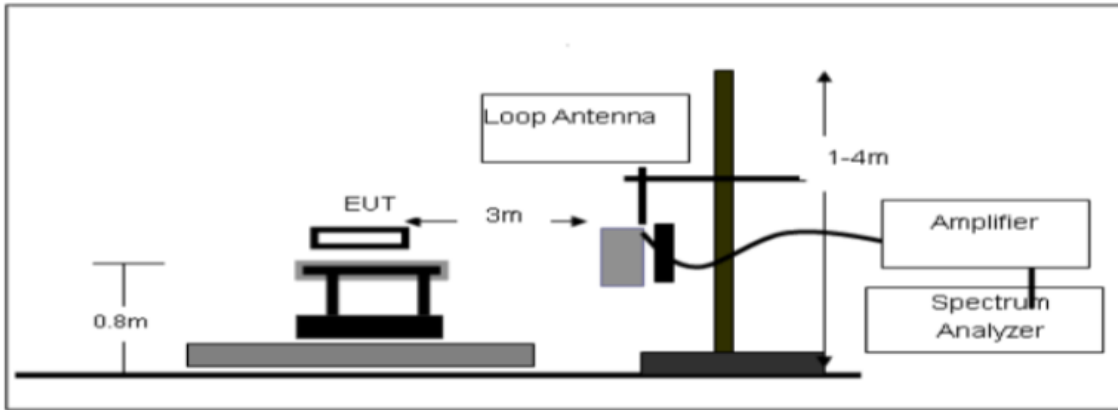

30MHz-1GHz

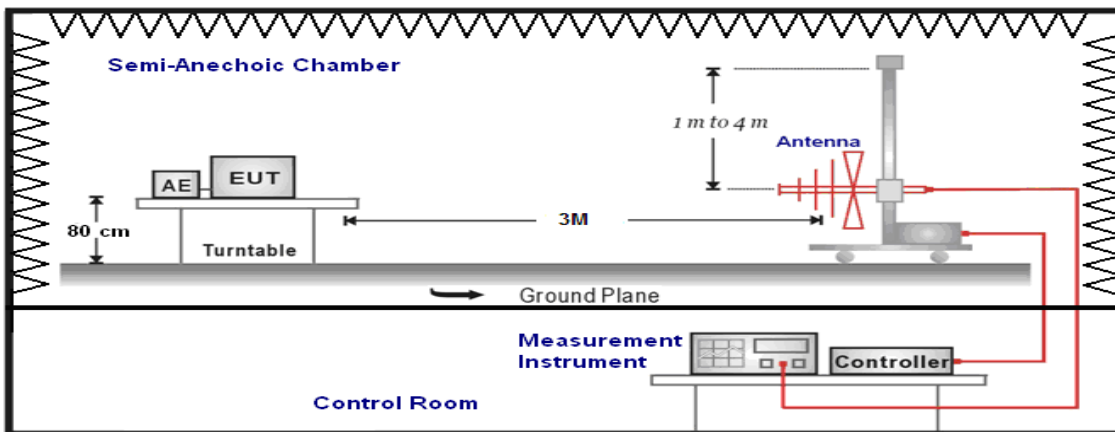

Above 1GHz

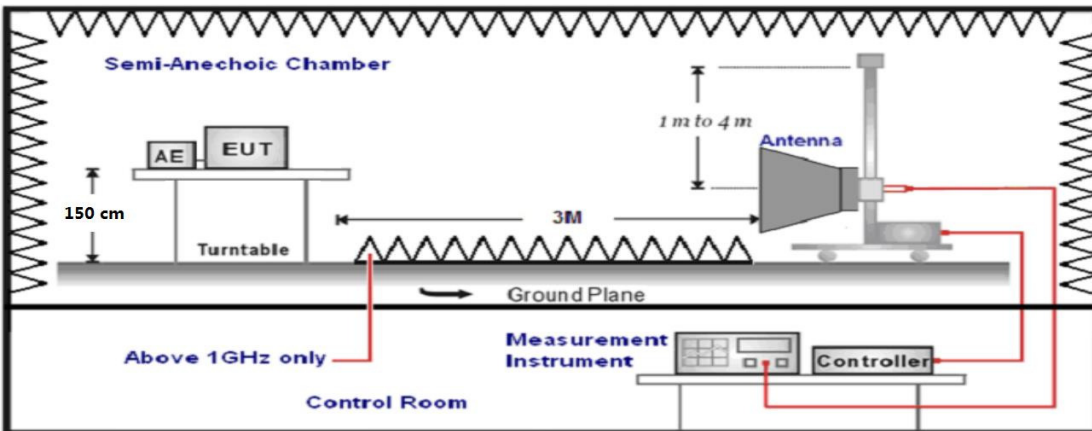

Test Procedure

Final radiation measurements were made on a three-meter, Semi Anechoic Chamber. The EUT system was placed on a nonconductive turntable (0.8 meters height for below 1 GHz and 1.5m height for above 1 GHz), top surface 1.0 x 1.5 meter. The spectrum was examined from 25 MHz to 2.5 GHz in order to cover the whole spectrum below 10th harmonic which could generate from the EUT. During the test, EUT was set to transmit continuously & Measurements spectrum range from 9 kHz to 26.5 GHz is investigated.

For measurements below 1 GHz the resolution bandwidth is set to 100 kHz for peak detection measurements or 120 kHz for quasi-peak detection measurements. Peak detection is used unless otherwise noted as quasi-peak.

For measurements above 1 GHz the resolution bandwidth is set to 1 MHz, and then the video bandwidth is set to 1 MHz for peak measurements and 10 Hz for average measurements.

A nonconductive material surrounded the EUT to supporting the EUT for standing on three orthogonal planes. At each condition, the EUT was rotated 360 degrees, and the antenna was raised and lowered from one to four meters to find the maximum emission levels. Measurements were taken using both horizontal and vertical antenna polarization.

SCHWARZBECK MESS-ELEKTRONIK Biconilog Antenna (mode VULB9163) at 3 Meter and the SCHWARZBECK Double Ridged Guide Antenna (model BBHA9120D&9170) was used in frequencies 1 – 26.5 GHz at a distance of 1 meter. All test results were extrapolated to equivalent signal at 3 meters utilizing an inverse linear distance extrapolation Factor (20dB/decade).

For testing above 1GHz, the emission level of the EUT in peak mode was 20dB lower than average limit (that means the emission level in peak mode also complies with the limit in average mode), then testing will be stopped and peak values of EUT will be reported, otherwise, the emissions will be measured in average mode again and reported.

Appropriate preamplifiers were used for improving sensitivity and precautions were taken to avoid overloading or desensitizing the spectrum analyzer. No post – detector video filters were used in the test.

The spectrum analyzer's 6 dB bandwidth was set to 1 MHz, and the analyzer was operated in the peak detection mode, for frequencies both below and up 1 GHz. The average levels were obtained by subtracting the duty cycle correction factor from the peak readings.

The following procedures were used to convert the emission levels measured in decibels referenced to 1 microvolt (dBuV) into field intensity in micro volts per meter (uV/m).

The actual field intensity in decibels referenced to 1 microvolt in to field intensity in micro volts per meter (dBuV/m).

The actual field intensity in decibels referenced to 1 microvolt per meter (dBuV/m) is determined by algebraically adding the measured reading in dBuV, the antenna factor (dB), and cable loss (dB) and Subtracting the gain of preamplifier (dB) is auto calculate in spectrum analyzer.

$$(1) \quad \text{Amplitude (dBuV/m)} = \text{FI (dBuV)} + \text{AF (dBuV)} + \text{CL (dBuV)} - \text{Gain (dB)}$$

FI= Reading of the field intensity.

AF= Antenna factor.

CL= Cable loss.

P.S Amplitude is auto calculate in spectrum analyzer.

$$(2) \quad \text{Actual Amplitude (dBuV/m)} = \text{Amplitude (dBuV)} - \text{Dis(dB)}$$

The FCC specified emission limits were calculated according the EUT operating frequency and by following linear interpolation equations:

(a) For fundamental frequency : Transmitter Output < +30dBm

(b) For spurious frequency : Spurious emission limits = fundamental emission limit /10

Data of measurement within this frequency range without mark in the table above means the reading of emissions are attenuated more than 20dB below the permissible limits or the field strength is too small to be measured.

Test Result

Below 1GHz

Standard:	FCC Part 15C	Test Distance:	3m
Test item:	Radiated Emission	Power:	AC 3.7V DC
Model Number:	BT2000B/37	Temp.(°C)/Hum.(%RH):	26(°C)/60%RH
Mode:	Mode 3	Date:	2015/02/12

Frequency (MHz)	Correct Factor (dB/m)	Result (dB)	Limit (dBuV/m)	Margin (dB)	Remark	Ant.Polar. H / V
30.18	-35.9	30.72	40.00	-9.28	QP	H
112.85	-35.8	26.68	43.50	-16.82	QP	H
124.92	-38.2	24.83	43.50	-18.67	QP	H
168.53	-38.8	21.68	43.50	-21.82	QP	H
441.69	-29.8	31.22	46.00	-14.78	QP	H
617.31	-26.4	39.45	46.00	-6.55	QP	H
30.18	-37.3	30.18	40.00	-9.82	QP	V
112.85	-35.2	31.42	43.50	-12.08	QP	V
124.92	-37.8	27.38	43.50	-16.12	QP	V
168.53	-38.6	24.45	43.50	-19.05	QP	V
441.69	-30.7	33.25	46.00	-12.75	QP	V
617.31	-27.1	38.48	46.00	-7.52	QP	V

Note: No emission found between lowest internal used/generated frequencies to 30MHz (9 kHz~30MHz).

We have pre-test all three modes, and the worst case is mode 3.

Above 1GHz

Standard:		FCC Part 15C		Test Distance:		3m	
Test item:		Radiated Emission		Power:		AC 3.7V DC	
Model Number:		BT2000B/37		Temp.(°C)/Hum.(%RH):		26(°C)/60%RH	
Mode:		Mode 3		Date:		2015/02/12	
Frequency:		2402 MHz		Test By:			
Frequency (MHz)	Reading (dBuV)	Correct Factor (dB/m)	Result (dBuV/m)	Limit (dBuV/m)	Margin (dB)	Remark	Ant.Polar. H / V
4804	49.9	5.8	55.7	74.0	-18.3	peak	H
4804	36.5	5.8	42.3	54.0	-11.7	Average	H
7206	--	6.8	--	74.0	--	peak	H
7206	--	6.8	--	54.0	--	Average	H
4804	47.8	5.8	53.6	74.0	-20.4	peak	V
4804	36.9	5.8	42.7	54.0	-11.3	Average	V
7206	--	6.8	--	74.0	--	peak	V
7206	--	6.8	--	54.0	--	Average	V

Standard:		FCC Part 15C		Test Distance:		3m	
Test item:		Radiated Emission		Power:		AC 3.7V DC	
Model Number:		BT2000B/37		Temp.(°C)/Hum.(%RH):		26(°C)/60%RH	
Mode:		Mode 3		Date:		2015/02/12	
Frequency:		2441 MHz		Test By:			
Frequency (MHz)	Reading (dBuV)	Correct Factor (dB/m)	Result (dBuV/m)	Limit (dBuV/m)	Margin (dB)	Remark	Ant.Polar. H / V
4882	48.5	5.9	54.4	74.0	-19.6	peak	H
4882	35.2	5.9	41.1	54.0	-12.9	Average	H
7323	--	6.8	--	74.0	--	peak	H
7323	--	6.8	--	54.0	--	Average	H
4882	46.9	5.9	52.8	74.0	-21.2	peak	V
4882	37.0	5.9	42.9	54.0	-11.1	Average	V
7323	--	6.8	--	74.0	--	peak	V
7323	--	6.8	--	54.0	--	Average	V

Standard:		FCC Part 15C		Test Distance:		3m	
Test item:		Radiated Emission		Power:		AC 3.7V DC	
Model Number:		BT2000B/37		Temp.(°C)/Hum.(%RH):		26(°C)/60%RH	
Mode:		Mode 3		Date:		2015/02/12	
Frequency:		2480 MHz		Test By:			
Frequency (MHz)	Reading (dBuV)	Correct Factor (dB/m)	Result (dBuV/m)	Limit (dBuV/m)	Margin (dB)	Remark	Ant.Polar. H / V
4960	46.0	5.9	51.9	74.0	-22.1	peak	H
4960	34.5	5.9	40.4	54.0	-13.6	Average	H
7440	--	6.8	--	74.0	--	peak	H
7440	--	6.8	--	54.0	--	Average	H
4960	47.3	5.9	53.2	74.0	-20.8	peak	V
4960	34.8	5.9	40.7	54.0	-13.3	Average	V
7440	--	6.8	--	74.0	--	peak	V
7440	--	6.8	--	54.0	--	Average	V

Note: --Only ground noise can be detected.

We have pre-test all three modes, and the worst case is mode 3.

9.4 20dB Bandwidth & 99% OBW Measurement Limit

N/A

Test Setup

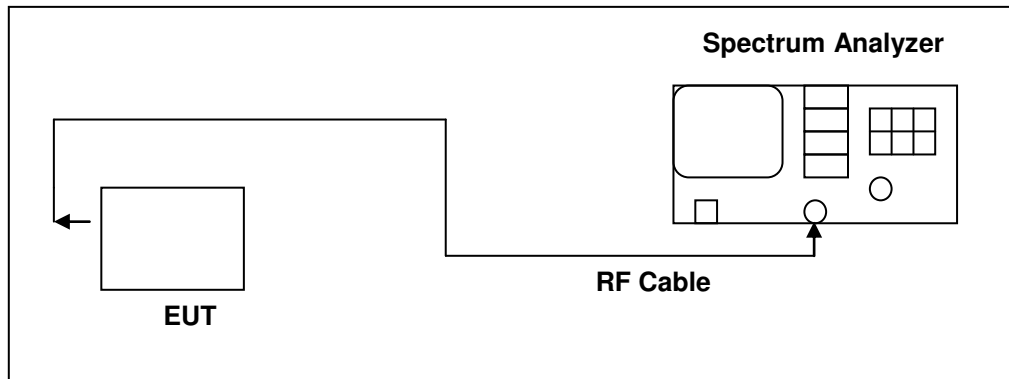

Test Instruments

Equipment	Manufacturer	Model Number	Serial Number	Cal. Date	Remark
Spectrum Analyzer	Agilent	N9020A	MY53420615	05/12/2014	(1)
RF cable	WOKEN	--	S02-140428-041	07/14/2014	(1)

Remark: (1) Calibration period 1 year. (2) Calibration period 2 years.

NOTE: N.C.R. = No Calibration Request.

Test Procedure

20dB RF Bandwidth

Testing must be done according to this procedure, FCC Public Notice DA 00-705 - Filing and Measurement Guidelines for Frequency Hopping Spread Spectrum Systems. This is the only method recognized by the FCC. The RF output port of the Equipment-Under-Test is directly coupled to the input of the EMC analyzer through a specialized RF connector and a 10dB passive attenuator. A fully charged battery was used for the supply voltage. The Bluetooth frequency hopping function of the EUT was enabled. The spectrum analyzer used the following settings:

1. Span = approx. 2 to 3 times the 20dB bandwidth, centered on a hopping frequency
2. RBW \geq 1% of the 20dB span
3. VBW \geq RBW
4. Sweep = auto
5. Detector function = peak
6. Trace = max hold

The trace was allowed to stabilize. The EUT was transmitting at its maximum data rate. The marker-to-peak function was used to set the marker to the peak of the emission. The marker-delta function was used to measure 20dB down one side



of the emission. The marker-delta function and marker was moved to the other side of the emission until it was even with the reference marker. The marker-delta reading at this point was the 20dB bandwidth of the emission.

Test Result

Model Number	BT2000B/37		
Test Item	20dB Bandwidth & 99% OBW		
Test Mode	Mode 1: GFSK Link Mode		
Date of Test	2015/02/15	Test Site	TE02
Frequency (MHz)	20dB Bandwidth (MHz)	99% OBW (MHz)	Limit (MHz)
2402	0.8755	0.8421	-----
2441	0.8739	0.8388	-----
2480	0.8741	0.8398	-----

Model Number	BT2000B/37		
Test Item	20dB Bandwidth & 99% OBW		
Test Mode	Mode 3: 8DPSK Link Mode		
Date of Test	2015/02/15	Test Site	TE02
Frequency (MHz)	20dB Bandwidth (MHz)	99% OBW (MHz)	Limit (MHz)
2402	1.2570	1.1549	-----
2441	1.2540	1.1551	-----
2480	1.2560	1.1548	-----

Test Graphs

Mode 1: GFSK Link Mode	
2402	
2441	
2480	

Mode 3: 8DPSK Link Mode	
2402	
2441	
2480	

9.5 Carrier Frequency Separation Measurement Limit

Title 47 of the CFR, Part 15 Subpart (c) 15.247(a)(1)(i) requires the measurement of the bandwidth of the transmission between the -20 dB points on the transmitted spectrum. The results of this test determine the limits for channel spacing. The channel spacing shall be a minimum of 25 kHz or the 20 dB bandwidth.

Test Setup

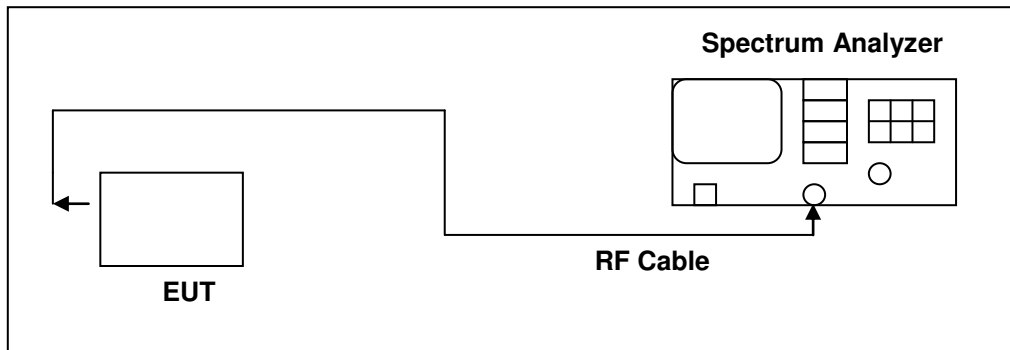

Test Instruments

Equipment	Manufacturer	Model Number	Serial Number	Cal. Date	Remark
Spectrum Analyzer	Agilent	N9020A	MY53420615	05/12/2014	(1)
RF cable	WOKEN	--	S02-140428-041	07/14/2014	(1)

Remark: (1) Calibration period 1 year. (2) Calibration period 2 years.

NOTE: N.C.R. = No Calibration Request.

Test Procedure

Testing must be done according to this procedure, FCC Public Notice DA 00-705 - Filing and Measurement Guidelines for Frequency Hopping Spread Spectrum Systems. This is the only method recognized by the FCC. The RF output port of the Equipment-Under-Test is directly coupled to the input of the EMC analyzer through a specialized RF connector and a 10dB passive attenuator. A fully charged battery was used for the supply voltage. The Bluetooth transmitter of the V6 had its hopping function enabled. The following spectrum analyzer settings were used:

1. Span = wide enough to capture the peaks of two adjacent channels
2. Resolution (or IF) Bandwidth (RBW) \geq 1% of the span
3. Video (or Average) Bandwidth (VBW) \geq RBW
4. Sweep = auto
5. Detector function = peak
6. Trace = max hold

The trace was allowed to stabilize. The marker-delta function was used to determine the separation between the peaks of the adjacent channels.

Test Result

Model Number	BT2000B/37		
Test Item	Carrier Frequency Separation		
Test Mode	Mode 1: GFSK Link Mode		
Date of Test	2015/02/15	Test Site	TE02
Frequency (MHz)	Measurement (MHz)	Limit (MHz)	
2441	1.000	> 0.584	

Model Number	BT2000B/37		
Test Item	Carrier Frequency Separation		
Test Mode	Mode 3: 8DPSK Link Mode		
Date of Test	2015/02/15	Test Site	TE02
Frequency (MHz)	Measurement (MHz)	Limit (MHz)	
2441	1.000	> 0.838	

Test Graphs

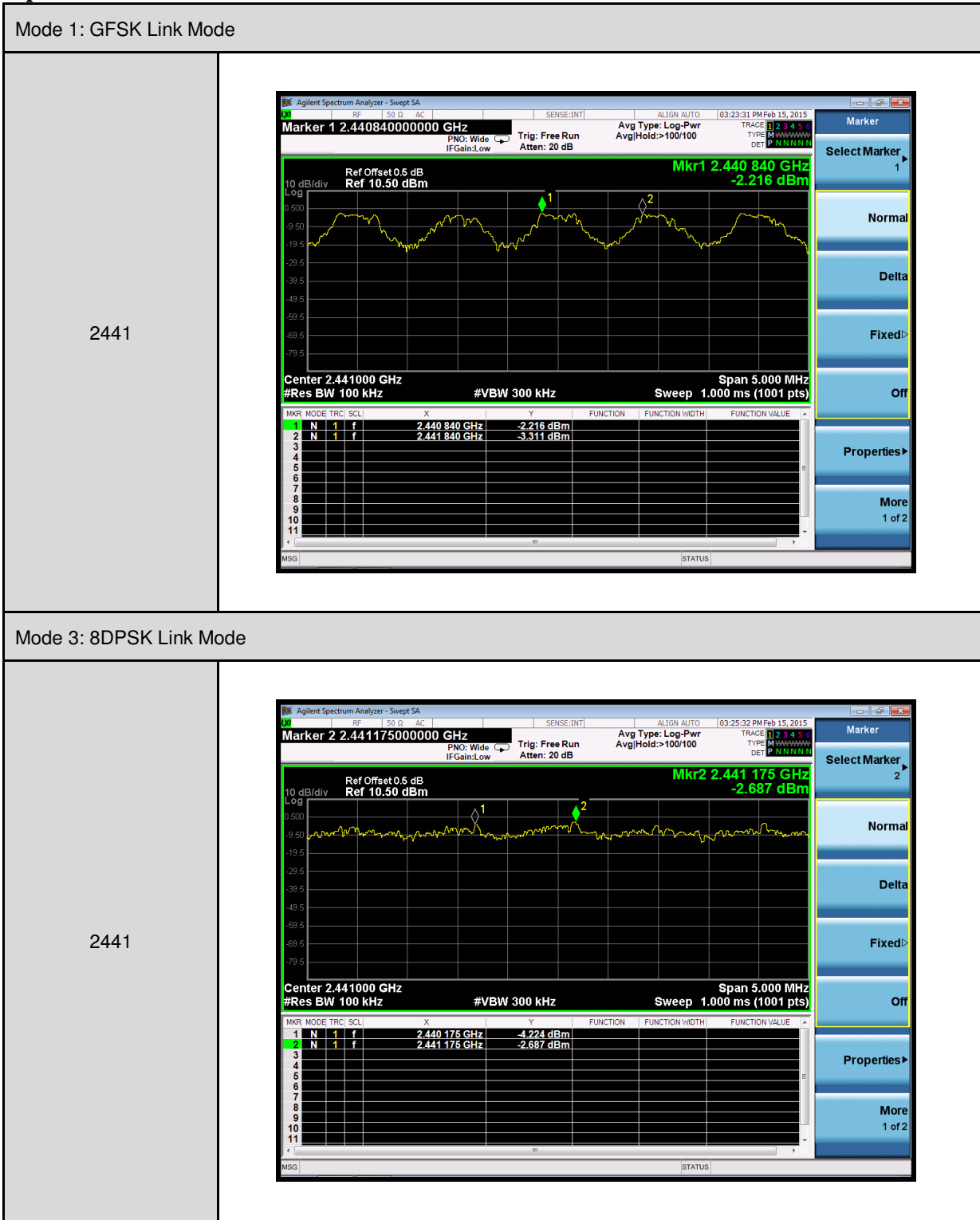

9.6 Number of Hopping Measurement Limit

Frequency hopping systems in the 2400–2483.5 MHz band shall use at least 15 channels.

Test Setup

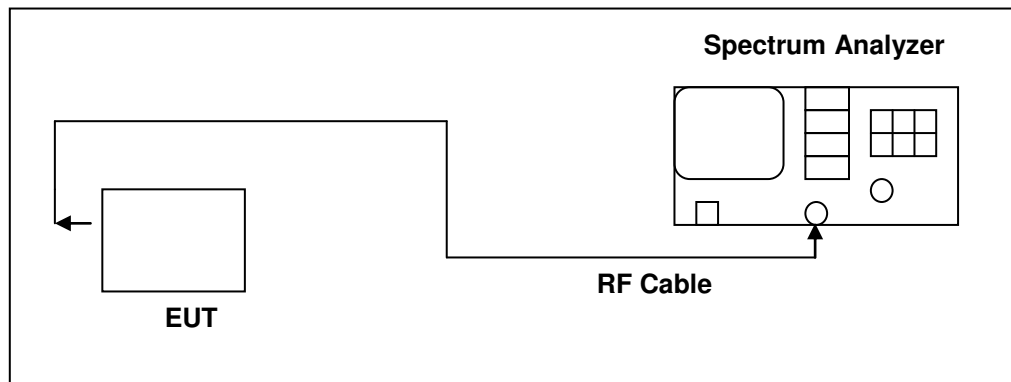

Test Instruments

Equipment	Manufacturer	Model Number	Serial Number	Cal. Date	Remark
Spectrum Analyzer	Agilent	N9020A	MY53420615	05/12/2014	(1)
RF cable	WOKEN	--	S02-140428-041	07/14/2014	(1)

Remark: (1) Calibration period 1 year. (2) Calibration period 2 years.

NOTE: N.C.R. = No Calibration Request.

Test Procedure

Testing must be done according to this procedure, FCC Public Notice DA 00-705 - Filing and Measurement Guidelines for Frequency Hopping Spread Spectrum Systems. This is the only method recognized by the FCC. The RF output port of the Equipment-Under-Test is directly coupled to the input of the EMC analyzer through a specialized RF connector and a 10dB passive attenuator. A fully charged battery was used for the supply voltage. The Bluetooth frequency hopping function of the EUT was enabled. The spectrum analyzer used the following settings:

1. Span = the frequency band of operation
2. RBW \geq 1% of the span
3. VBW \geq RBW
4. Sweep = auto
5. Detector function = peak
6. Trace = max hold

The trace was allowed to stabilize.

Test Result

Model Number	BT2000B/37		
Test Item	Number of Hopping		
Test Mode	Mode 1: GFSK Link Mode		
Date of Test	2015/02/15	Test Site	TE02
Frequency Range (MHz)	Measurement (ch)	Limit (ch)	
2402 - 2480	79	> 15	

Model Number	BT2000B/37		
Test Item	Number of Hopping		
Test Mode	Mode 3: 8DPSK Link Mode		
Date of Test	2015/02/15	Test Site	TE02
Frequency Range (MHz)	Measurement (ch)	Limit (ch)	
2402 - 2480	79	> 15	

Test Graphs

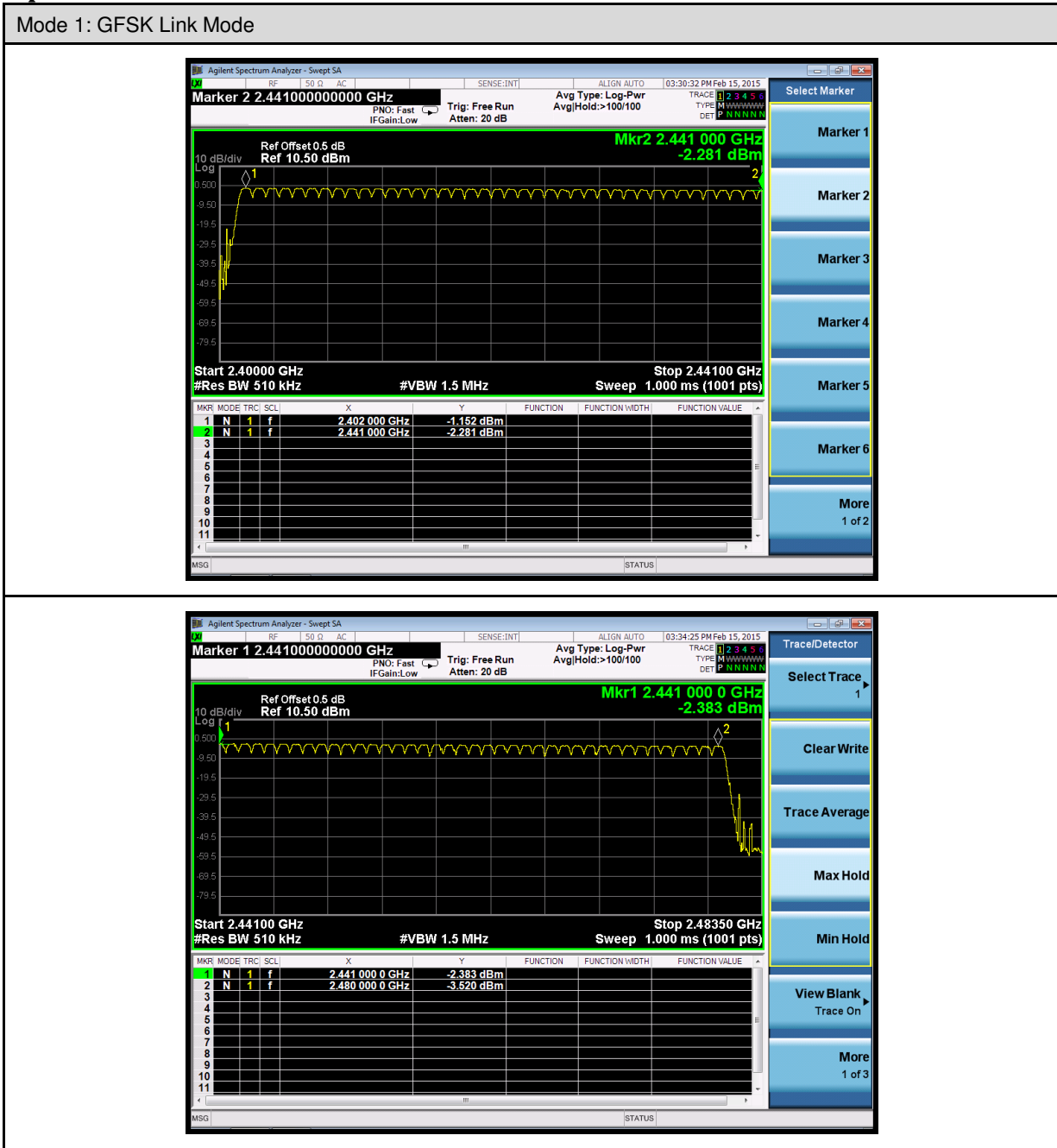

Mode 3: 8DPSK Link Mode

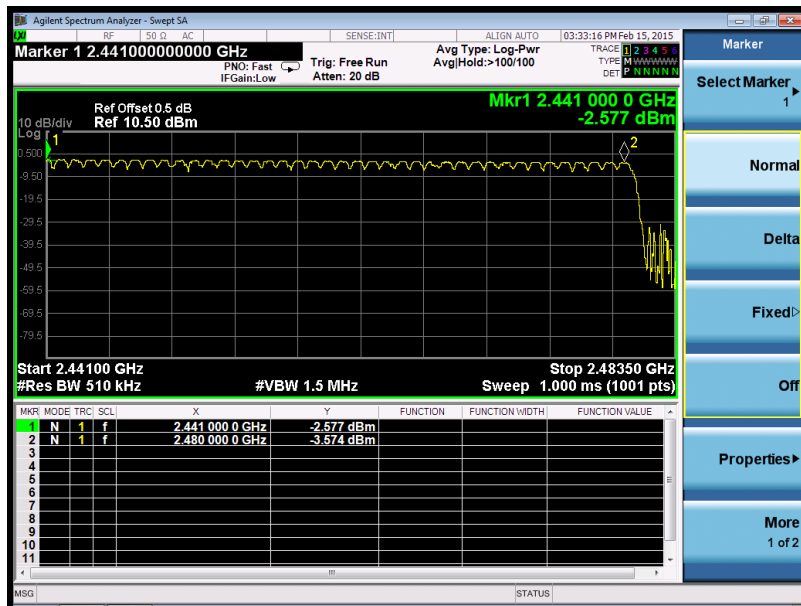
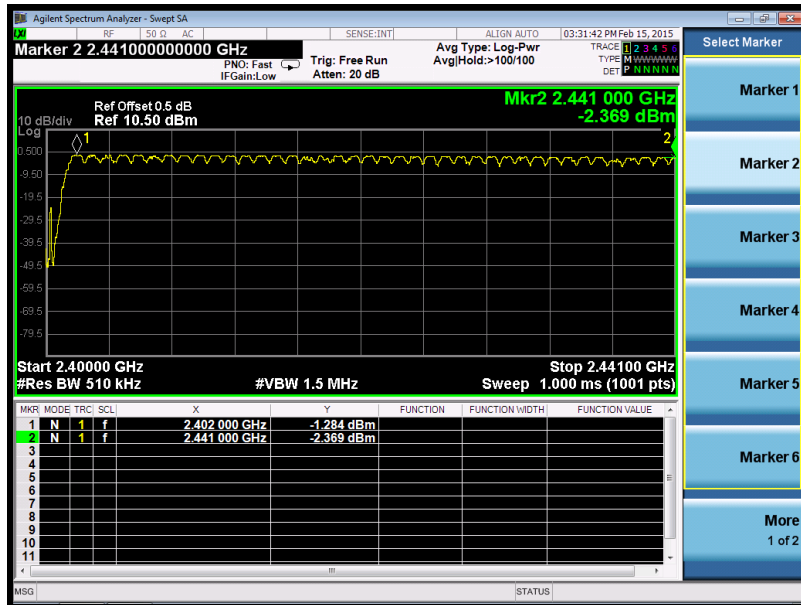

9.7 Time of Occupancy (Dwell Time) Measurement Limit

The average time of occupancy on any channel shall not be greater than 0.4 seconds within a period of 0.4 seconds multiplied by the number of hopping channels employed.

Test Setup

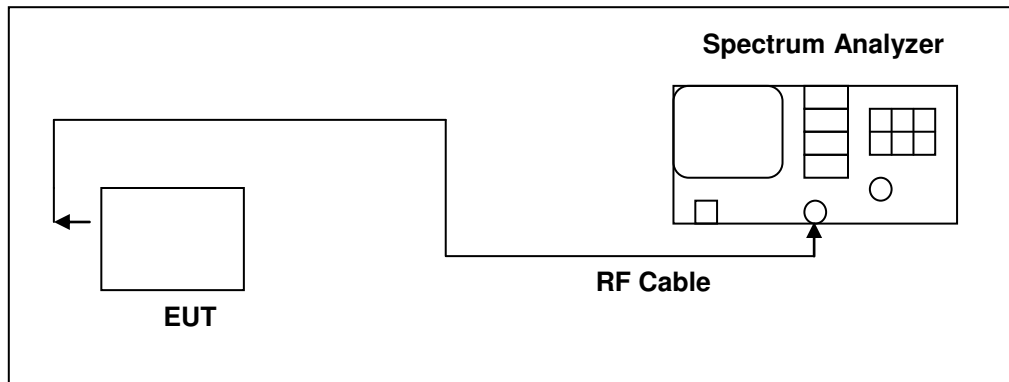

Test Instruments

Equipment	Manufacturer	Model Number	Serial Number	Cal. Date	Remark
Spectrum Analyzer	Agilent	N9020A	MY53420615	05/12/2014	(1)
RF cable	WOKEN	--	S02-140428-041	07/14/2014	(1)

Remark: (1) Calibration period 1 year. (2) Calibration period 2 years.

NOTE: N.C.R. = No Calibration Request.

Test Procedure

Testing must be done according to this procedure, FCC Public Notice DA 00-705 - Filing and Measurement Guidelines for Frequency Hopping Spread Spectrum Systems. This is the only method recognized by the FCC. The RF output port of the Equipment-Under-Test is directly coupled to the input of the EMC analyzer through a specialized RF connector and a 10dB passive attenuator. A fully charged battery was used for the supply voltage. The Bluetooth hopping function of the EUT was enabled. The following spectrum analyzer settings were used:

1. Span = zero span, centered on a hopping channel
2. RBW = 1 MHz
3. VBW \geq RBW
4. Sweep = as necessary to capture the entire dwell time per hopping channel
5. Detector function = peak
6. Trace = max hold

The marker-delta function was used to determine the dwell time.

Test Result

Model Number	BT2000B/37		
Test Item	Time of Occupancy (Dwell Time)		
Test Mode	Mode 1: GFSK Link Mode		
Date of Test	2015/02/15	Test Site	TE02
DH1			
Length of per burst(ms)	0.403		
Number of burst in 5 seconds	25		
Cycle Calculate	$79CH * 0.4 = 31.6$ (sec)		
Dwell Times	$31.6/5 * 25 * 0.403 = 63.674$		
LIMIT(msec)	$< = 400$		
DH3			
Length of per burst(ms)	1.667		
Number of burst in 5 seconds	23		
Cycle Calculate	$79CH * 0.4 = 31.6$ (sec)		
Dwell Times	$31.6/5 * 23 * 1.667 = 242.315$		
LIMIT(msec)	$< = 400$		
DH5			
Length of per burst(ms)	2.920		
Number of burst in 5 seconds	15		
Cycle Calculate	$79CH * 0.4 = 31.6$ (sec)		
Dwell Times	$31.6/5 * 15 * 2.920 = 276.816$		
LIMIT(msec)	$< = 400$		

Model Number	BT2000B/37		
Test Item	Time of Occupancy (Dwell Time)		
Test Mode	Mode 3: 8DPSK Link Mode		
Date of Test	2015/02/15	Test Site	TE02
DH1			
Length of per burst(ms)	0.400		
Number of burst in 5 seconds	27		
Cycle Calculate	$79CH * 0.4 = 31.6$ (sec)		
Dwell Times	$31.6/5 * 27 * 0.400 = 68.256$		
LIMIT(msec)	$< = 400$		
DH3			
Length of per burst(ms)	1.667		
Number of burst in 5 seconds	24		
Cycle Calculate	$79CH * 0.4 = 31.6$ (sec)		
Dwell Times	$31.6/5 * 24 * 1.667 = 252.851$		
LIMIT(msec)	$< = 400$		
DH5			
Length of per burst(ms)	2.920		
Number of burst in 5 seconds	12		
Cycle Calculate	$79CH * 0.4 = 31.6$ (sec)		
Dwell Times	$31.6/5 * 12 * 2.920 = 221.453$		
LIMIT(msec)	$< = 400$		

Test Graphs

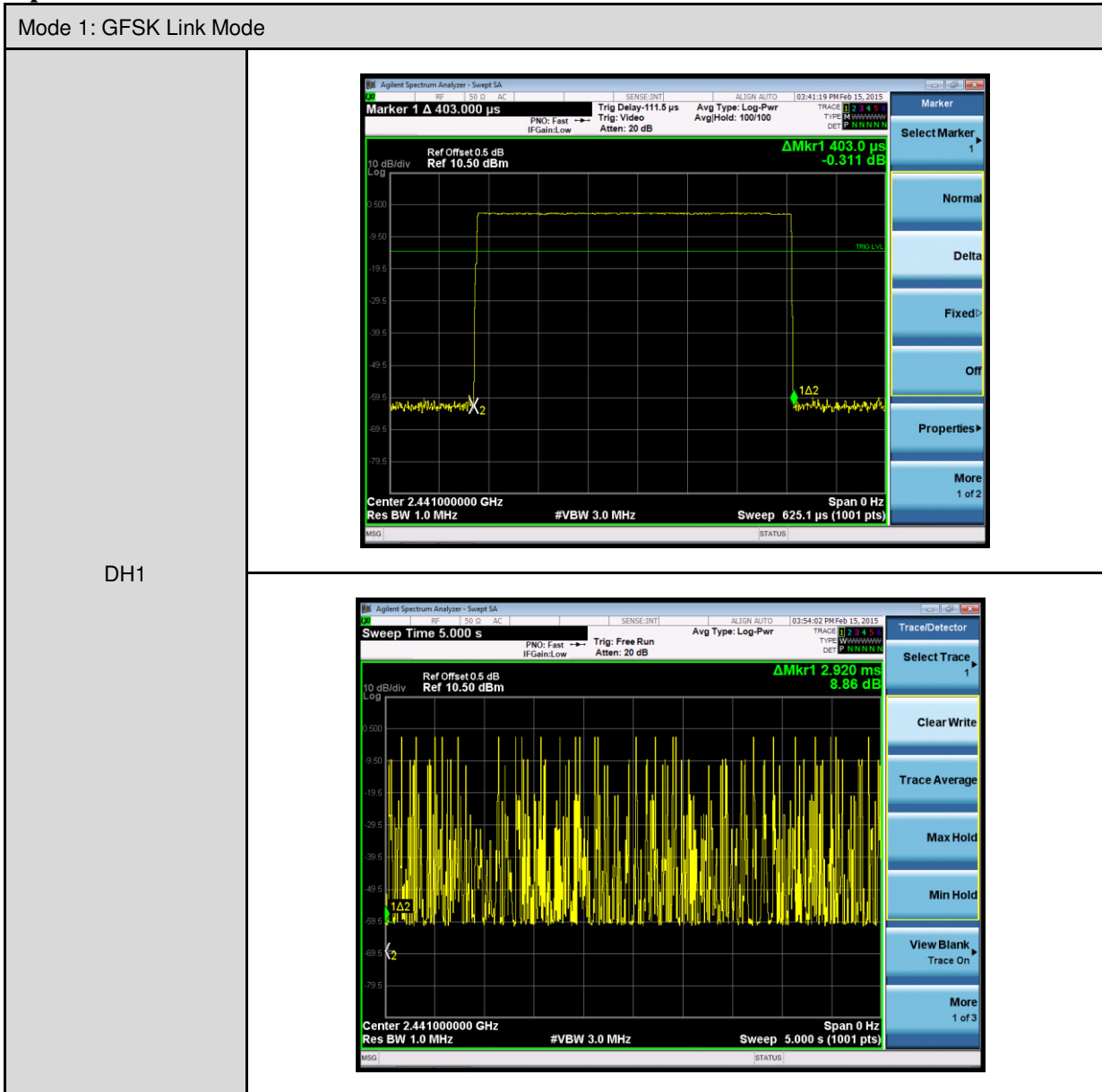

Mode 1: GFSK Link Mode

DH3

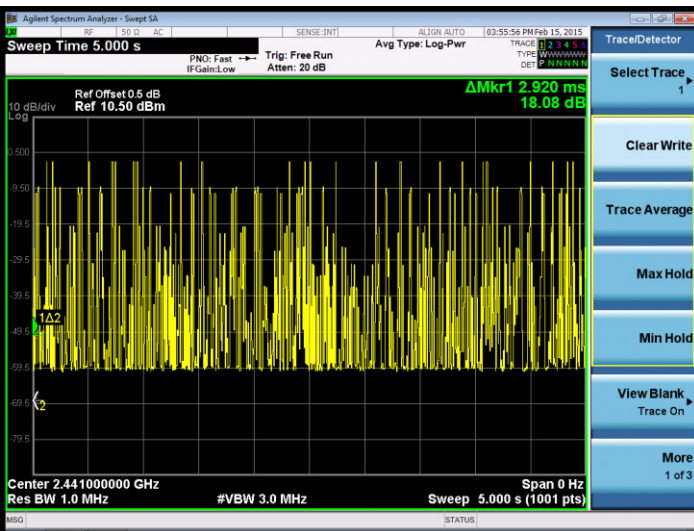
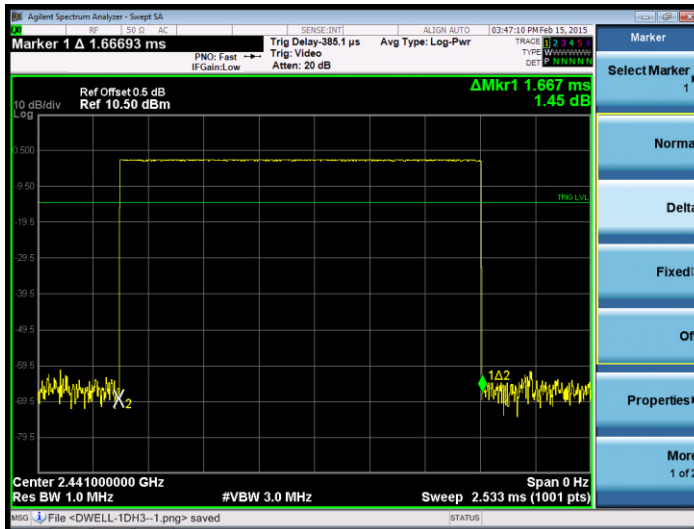

Mode 1: GFSK Link Mode

DH5

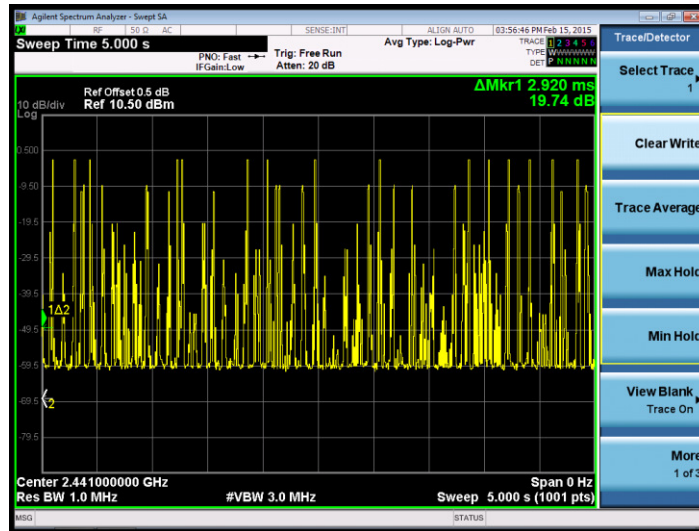
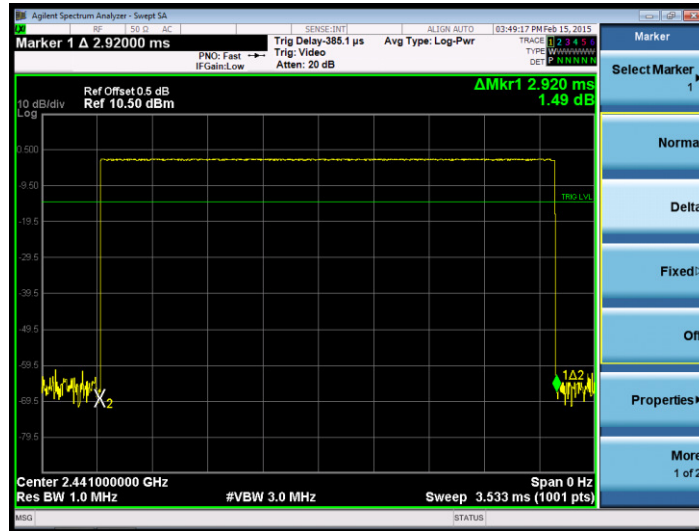

Mode 3: 8DPSK Link Mode

3DH1

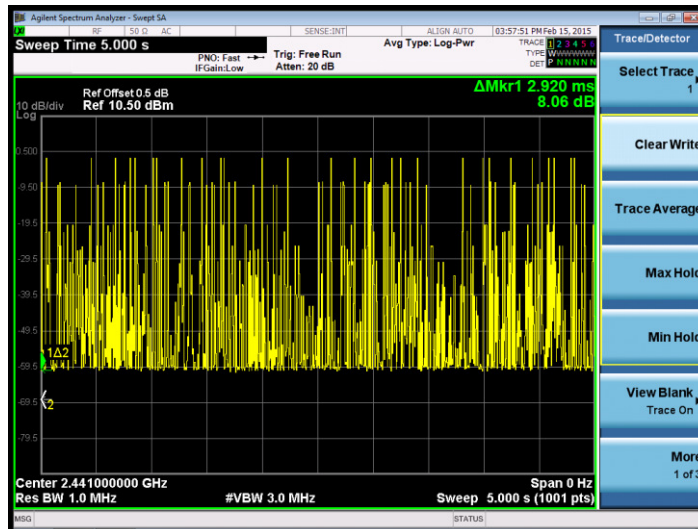
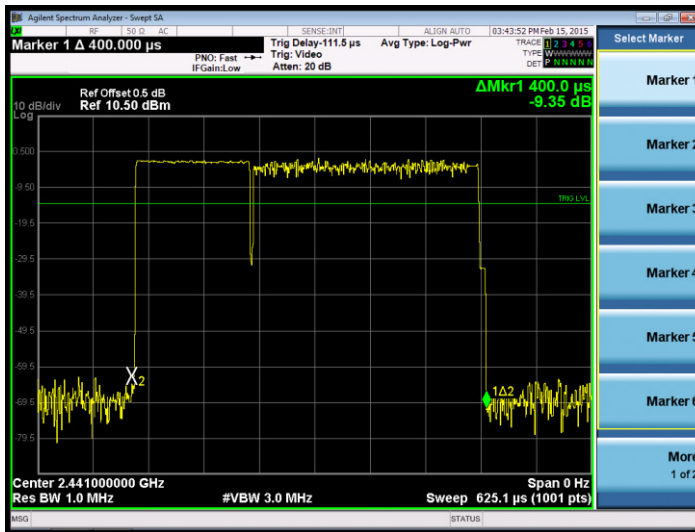

Mode 3: 8DPSK Link Mode

3DH3

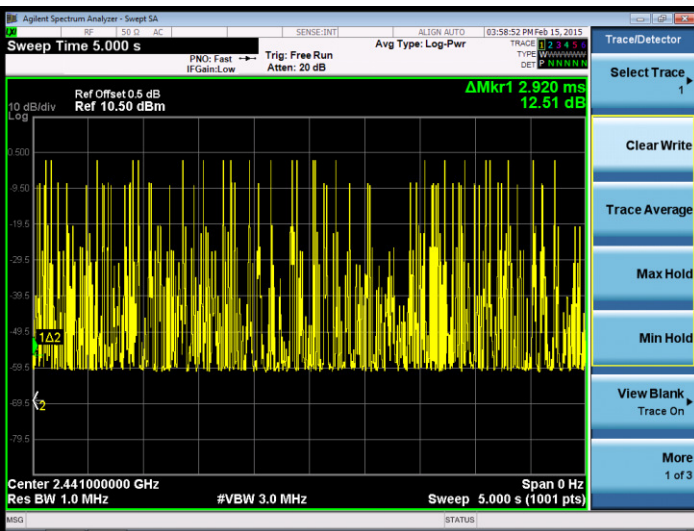
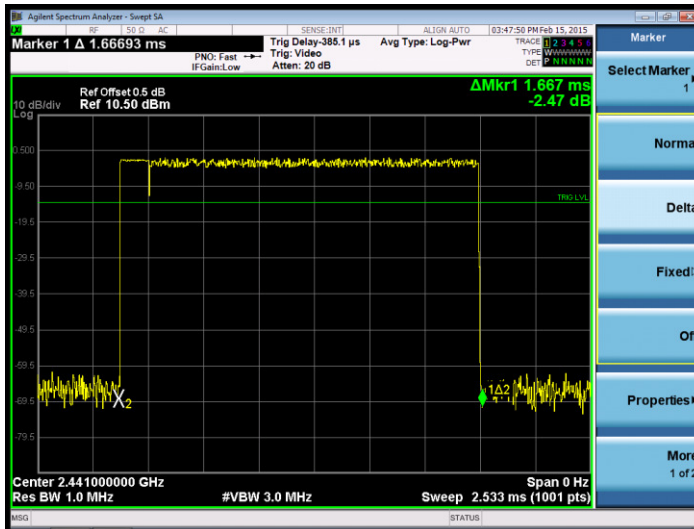

Mode 3: 8DPSK Link Mode

3DH5

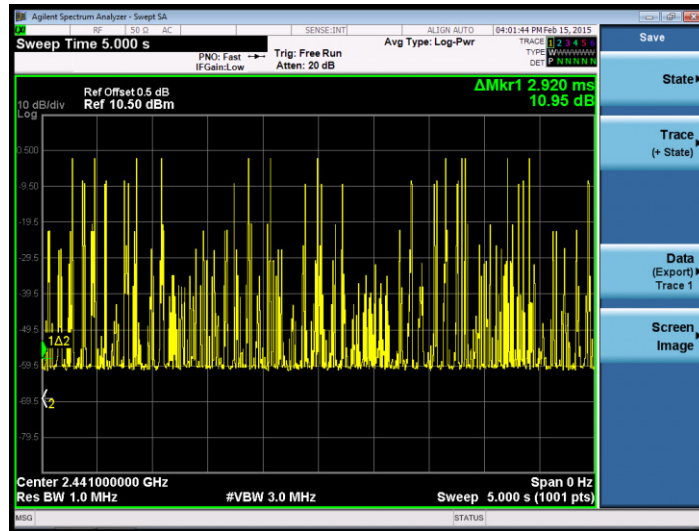
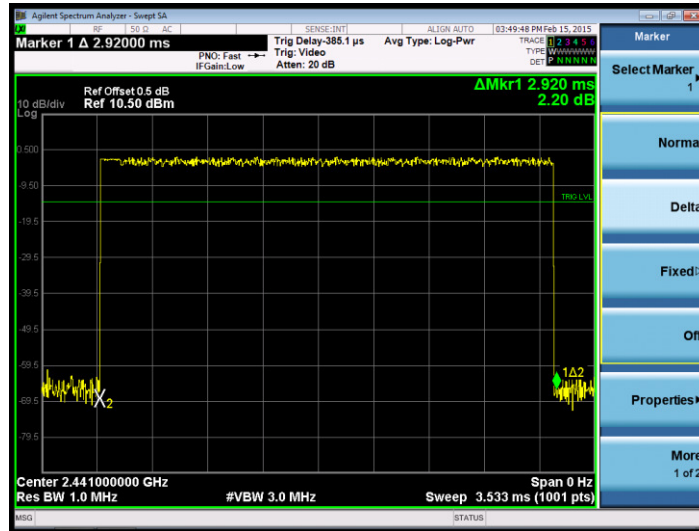

9.8 Out of Band Conducted Emissions Measurement

Limit

In any 100 kHz bandwidth outside the frequency band in which the spread spectrum or digitally modulated intentional radiator is operating, the radio frequency power that is produced by the intentional radiator shall be at least 20 dB below that in the 100 kHz bandwidth within the band that contains the highest level of the desired power

Test Setup

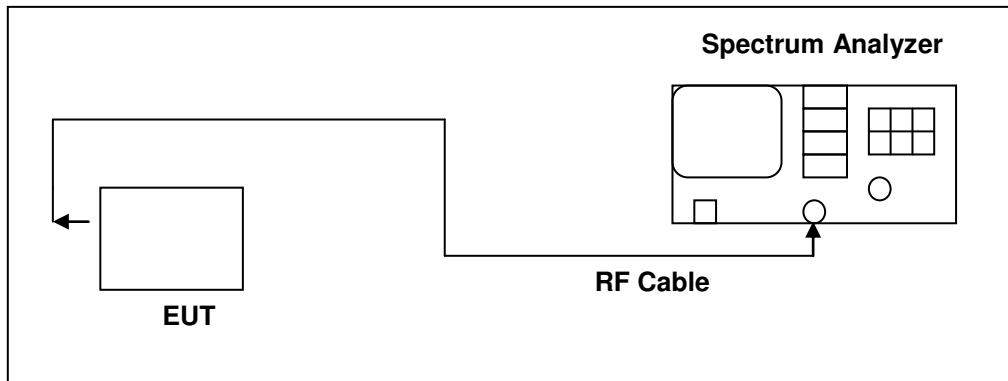

Test Instruments

Equipment	Manufacturer	Model Number	Serial Number	Cal. Date	Remark
Spectrum Analyzer	Agilent	N9020A	MY53420615	05/12/2014	(1)
RF cable	WOKEN	--	S02-140428-041	07/14/2014	(1)

Remark: (1) Calibration period 1 year. (2) Calibration period 2 years.

NOTE: N.C.R. = No Calibration Request.

Test Procedure

Testing must be done according to this procedure, FCC Public Notice DA 00-705 - Filing and Measurement Guidelines for Frequency Hopping Spread Spectrum Systems. This is the only method recognized by the FCC. In any 100 kHz bandwidth outside the EUT pass band, the RF power produced by the modulation products of the spreading sequence, the information sequence, and the carrier frequency shall be at least 20 dB below that of the maximum in-band 100 kHz emission, antenna output of the EUT was coupled directly to spectrum analyzer; if an external attenuator and/or cable was used, these losses are compensated for with the analyzer OFFSET function.

All other types of emissions from the EUT shall meet the general limits for radiated frequencies outside the pass band. The test was performed at 3 channels (Channel 0, 39, 78)

Test Graphs

Low channel: 2402MHz

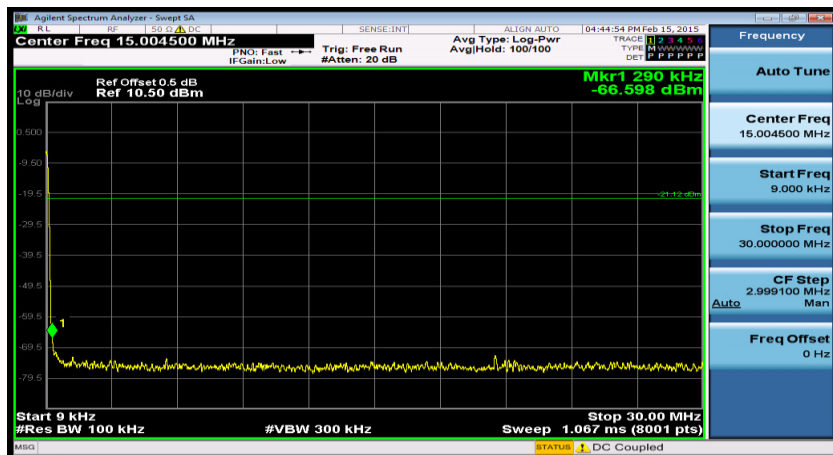

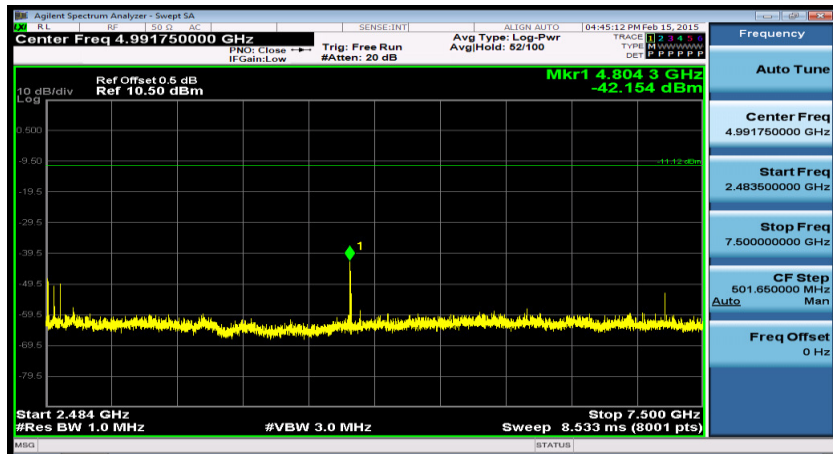
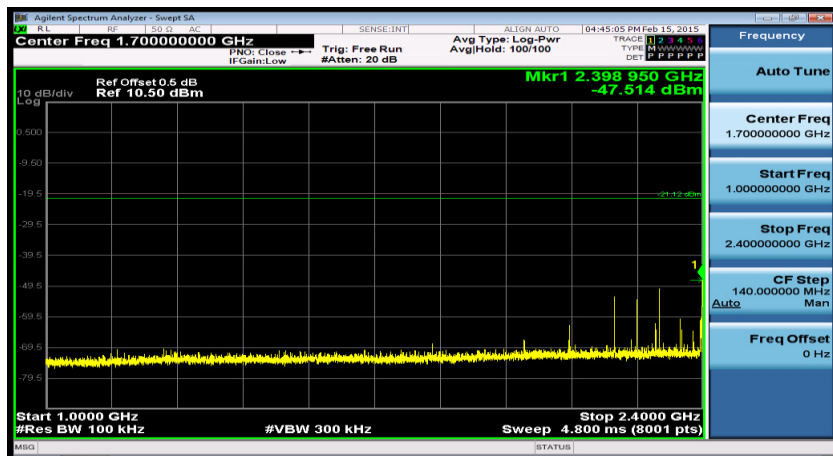
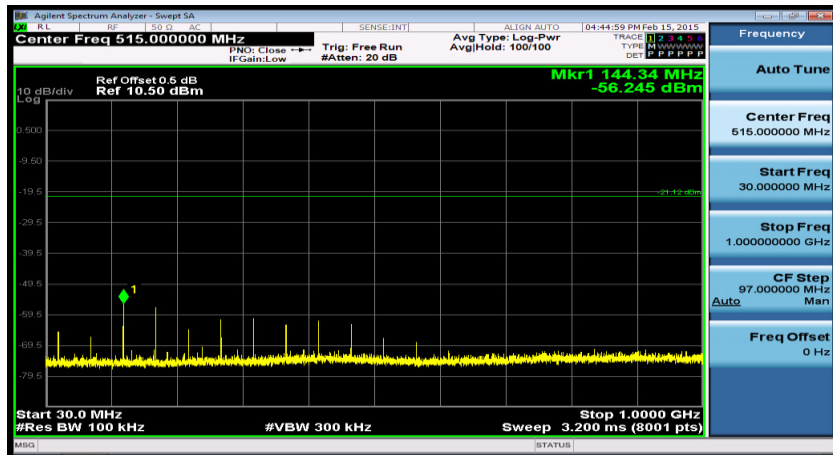

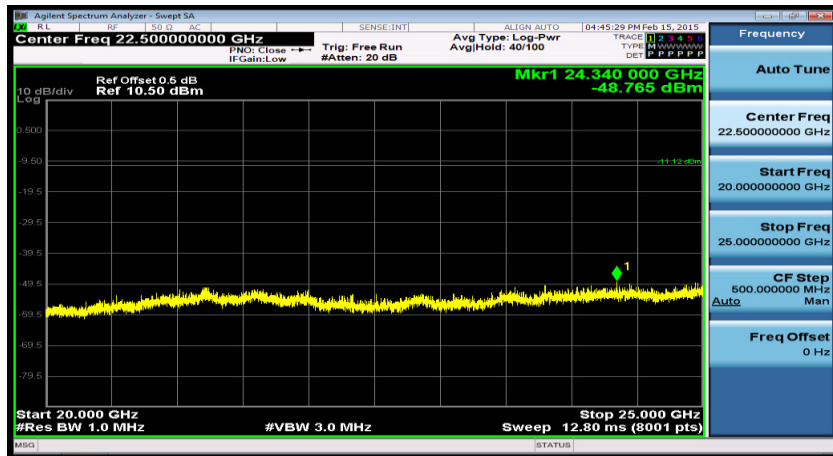
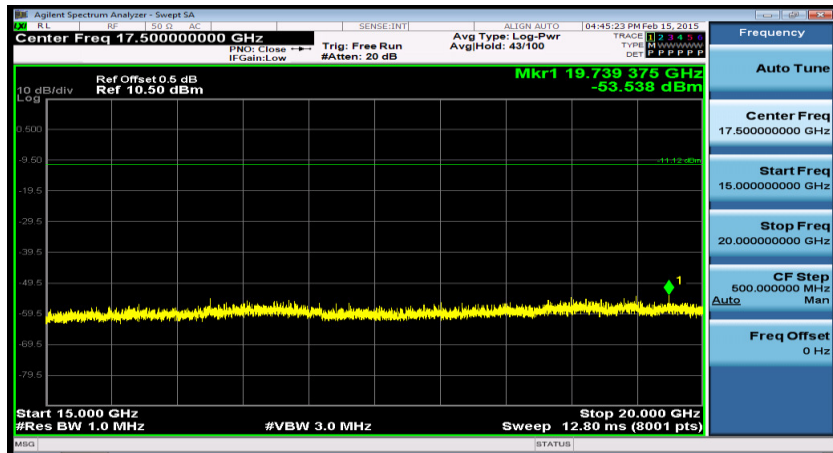
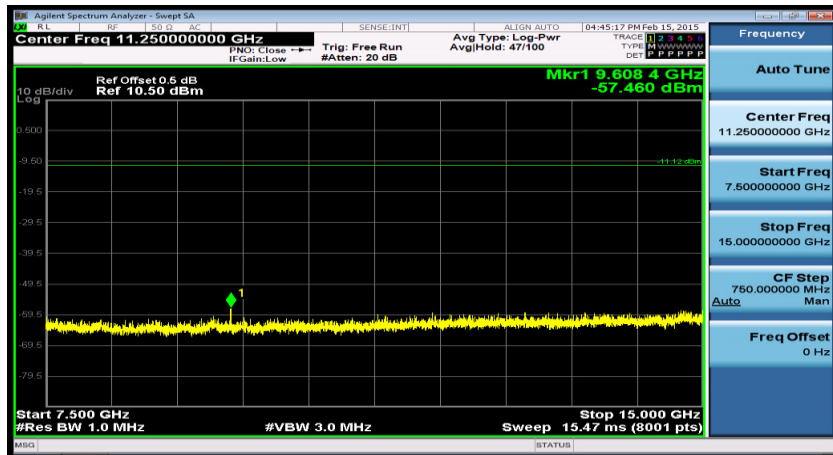

Middle channel: 2441MHz

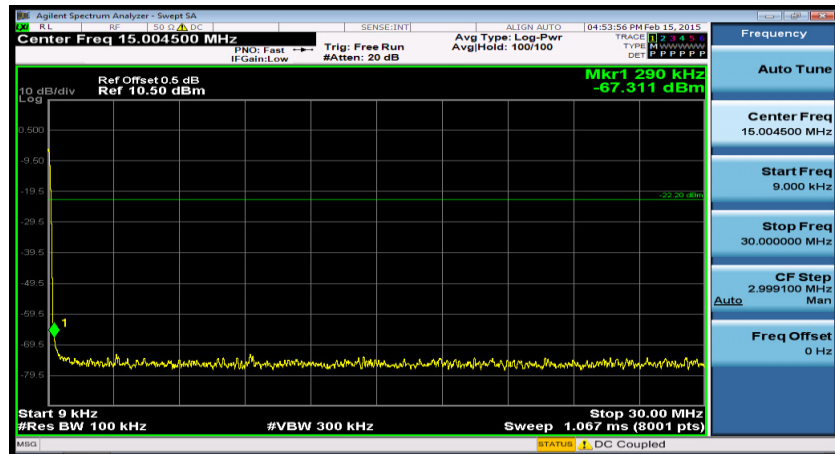

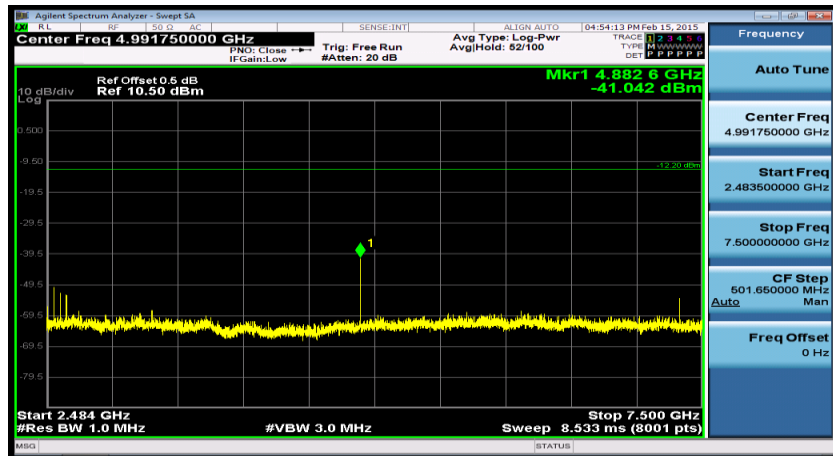
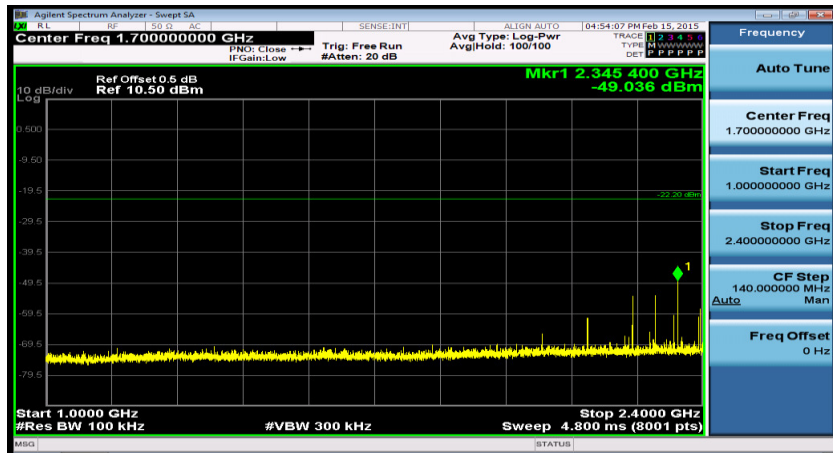
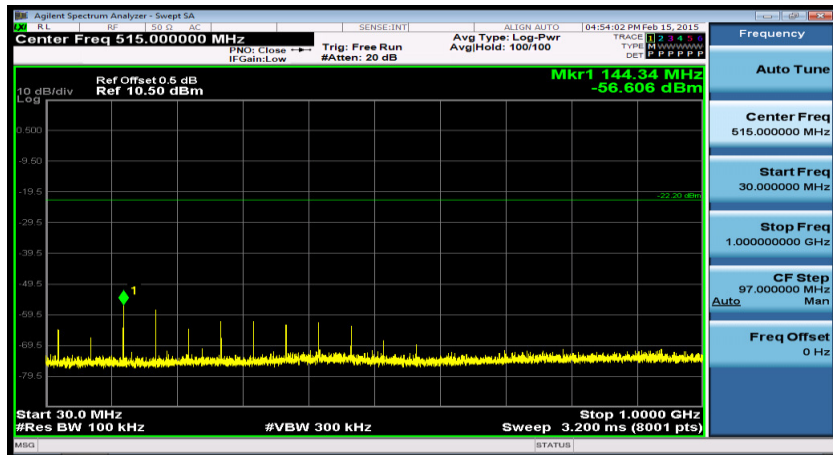

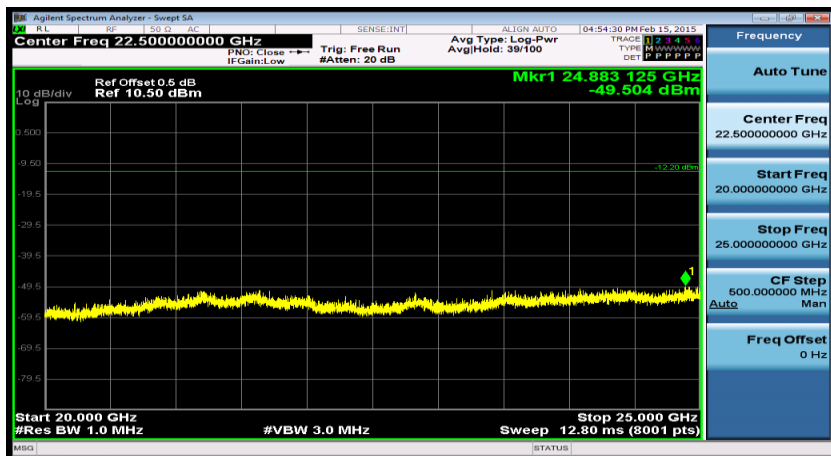
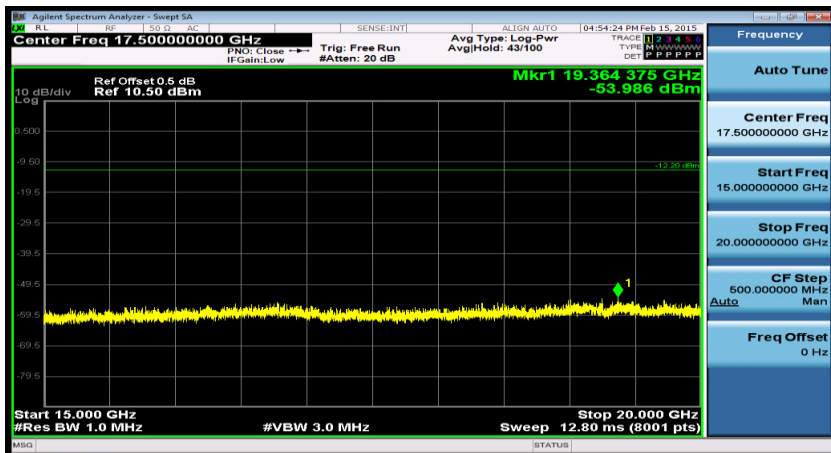
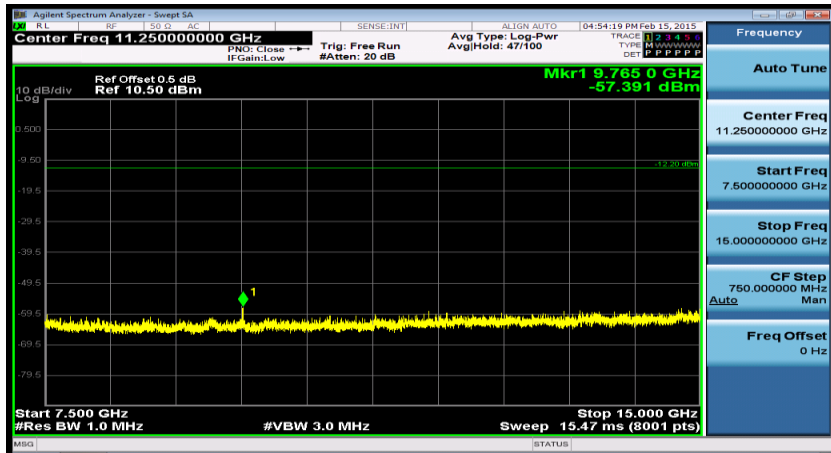

Middle channel: 2441MHz

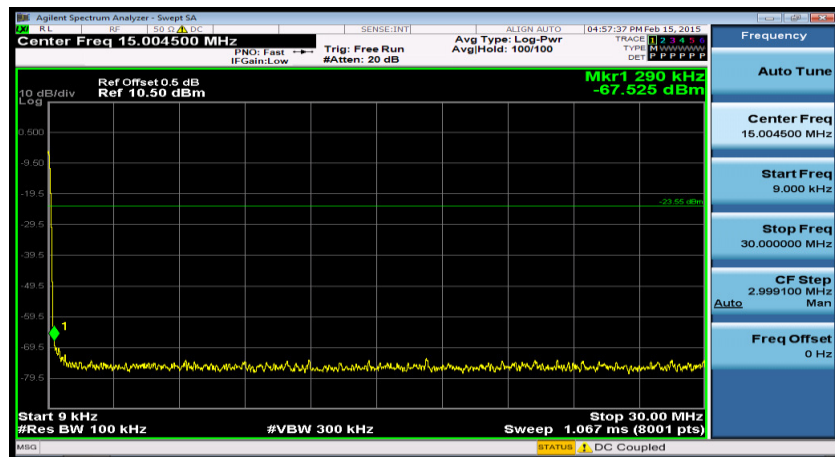



Hong Kong

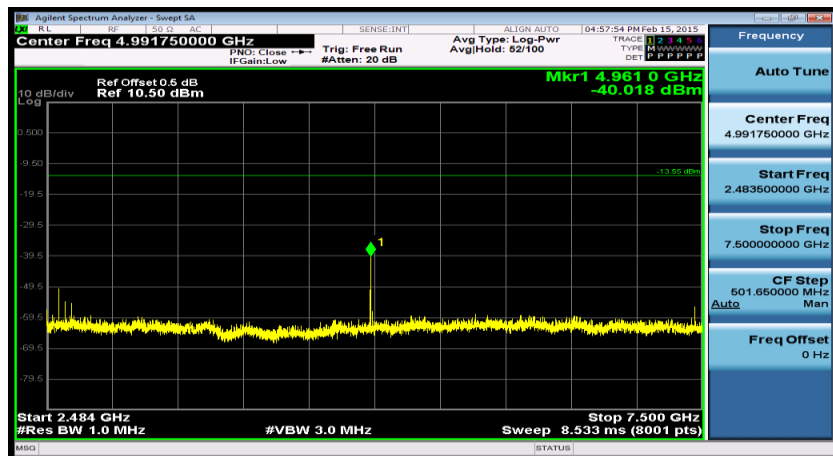
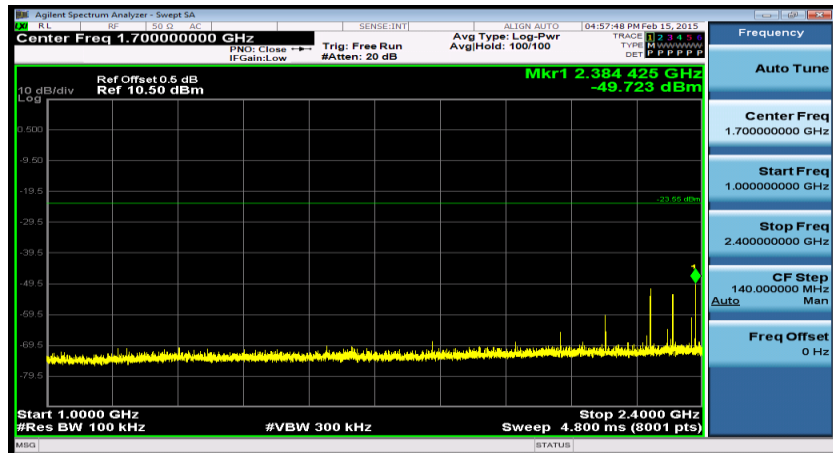
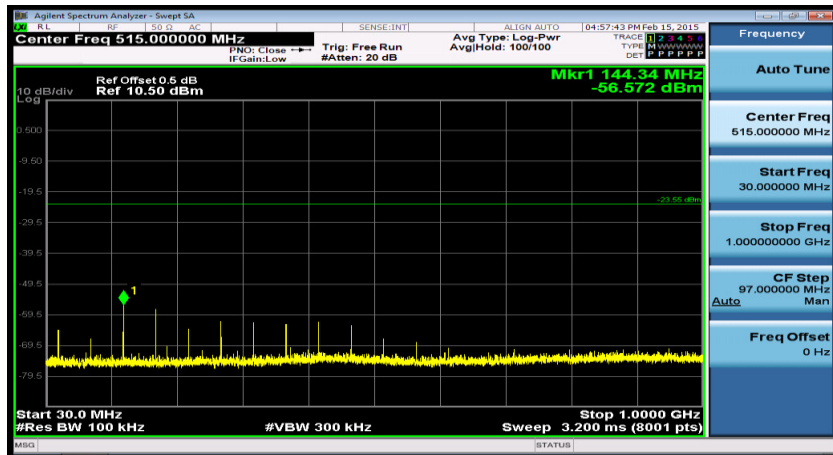



Hong Kong

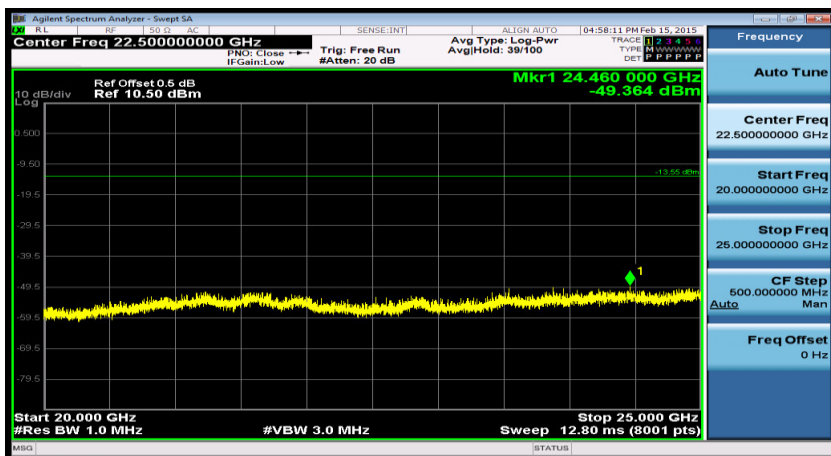
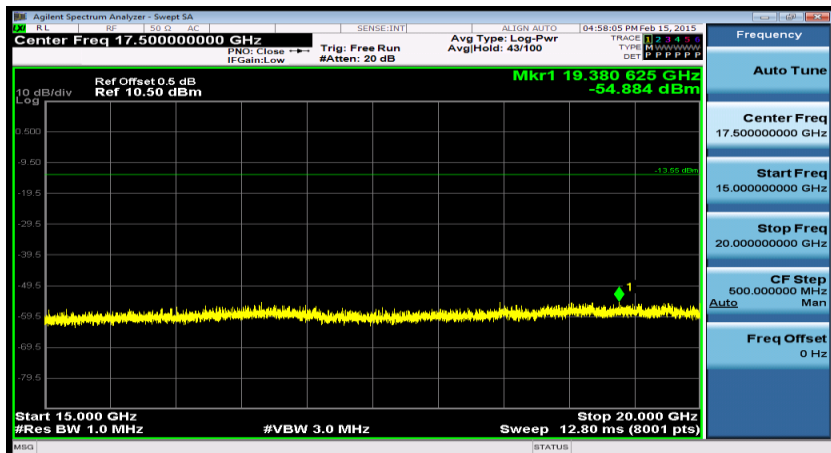
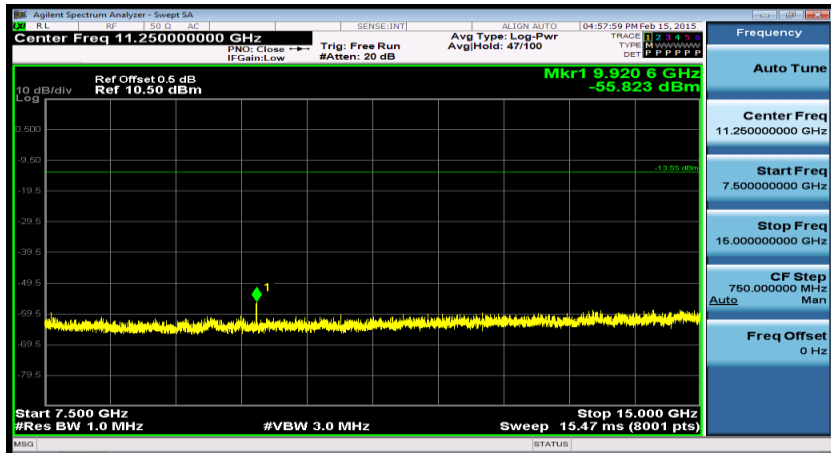

9.9 Band Edges Measurement Limit

In any 100 kHz bandwidth outside the frequency band in which the spread spectrum or digitally modulated intentional radiator is operating, the radio frequency power that is produced by the intentional radiator shall be at least 20 dB below that in the 100 kHz bandwidth within the band that contains the highest level of the desired power

Test Setup

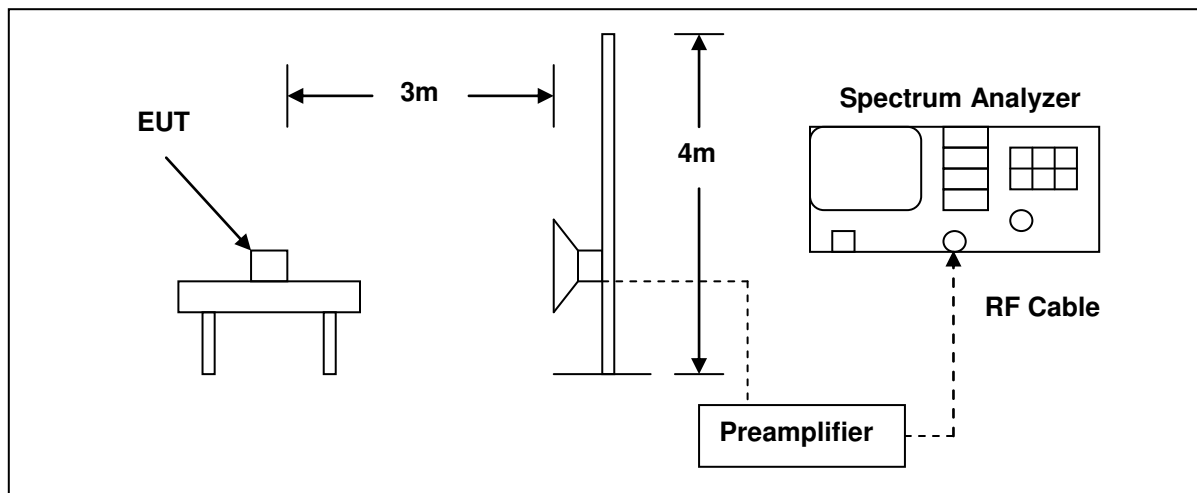

Test Instruments

Equipment	Manufacturer	Model Number	Serial Number	Cal. Date	Remark
EMI Test Receiver	R&S	ESU40	SB8501/09	05/16/2014	(1)
Bilog Antenna	Schwarzbeck	Schwarzbeck	SB8501/04	01/20/2015	(1)
Horn Antenna	R&S	HF906	SB3435	01/20/2015	(1)
Amplifier(1-18GHz)	R&S	--	SB3435/01	01/20/2015	(1)
Amplifier(18-40GHz)	R&S	--	SB3435/02	01/20/2015	(1)
Horn Antenna	Amplifier Research	AT4560	SB5392/02	05/16/2014	(1)
RF cable(0.4m)	Woken	/	S02-1404-09-065	05/11/2014	(1)
RF cable(3.5m)	Woken	/	S02-1404-09-047	05/11/2014	(1)
RF cable(1.2m)	Woken	/	S02-1404-09-052	05/11/2014	(1)
3m Semi-anechoic chamber	Albatross Projects	9X6X6	SB3450/01	10/12/2014	(1)

Remark: (1) Calibration period 1 year. (2) Calibration period 2 years.

NOTE: N.C.R. = No Calibration Request.



Test Procedure

Testing must be done according to this procedure, FCC Public Notice DA 00-705 - Filing and Measurement Guidelines for Frequency Hopping Spread Spectrum Systems. This is the only method recognized by the FCC. The emissions on the harmonics frequencies, the limits, and the margin of compliance are presented. These tests were made when the transmitter was in full radiated power. The additional test was performed to show compliance with the requirement at the band-edge frequency 2483.5 MHz and up to 2500 MHz and at 2390.0 MHz.

The transmitter was configured with the worst case antenna and setup to transmit at the highest channel. Then the field strength was measured at 2483.5 MHz.

The transmitter was then configured with the worst case antenna and setup to transmit at the lowest channel. Then the field strength was measured at 2390.0 MHz. These tests were performed at 4 different bit rates.

For measurements the resolution bandwidth is set to 1 MHz, and then the video bandwidth is set to 1 MHz for peak measurements and 10 Hz for average measurements.

Test Result

Standard:	FCC Part 15C	Test Distance:	3m
Test item:	Radiated Bandedge	Power:	AC 3.7V DC
Model Number:	BT2000B/37	Temp.(°C)/Hum.(%RH):	26(°C)/60%RH
Mode:	Mode 3	Date:	2015/02/12
Frequency:		Test By:	

Channel	Frequency (MHz)	Result (dBuV/m)	Limit (dBuV/m)	Margin (dB)	Remark	Ant.Polar. H / V
2402MHz	2389.6	44.7	74.0	-29.3	peak	H
	2389.6	32.6	54.0	-21.4	Average	H
	2390.0	46.1	74.0	-27.9	peak	V
	2390.0	33.5	54.0	-20.5	Average	V
2480MHz	2483.5	51.2	74.0	-22.8	peak	H
	2483.5	39.4	54.0	-14.6	Average	H
	2483.5	52.5	74.0	-21.5	peak	V
	2483.5	38.9	54.0	-15.1	Average	V

Note: Mode 3 is the worst case.

Model Number	BT2000B/37		
Test Item	Conducted Bandedge		
Test Mode	Mode 3: 8DPSK Link Mode		
Date of Test	2015/02/15	Test Site	TE02
	Frequency (MHz)	Delta Peak to Band Emission (dB)	Limit (dB)
Hopping off	2402	39.282	>20
	2480	46.094	>20
Hopping on	2402	39.879	>20
	2480	46.172	>20

Note: Mode 3 is the worst case.

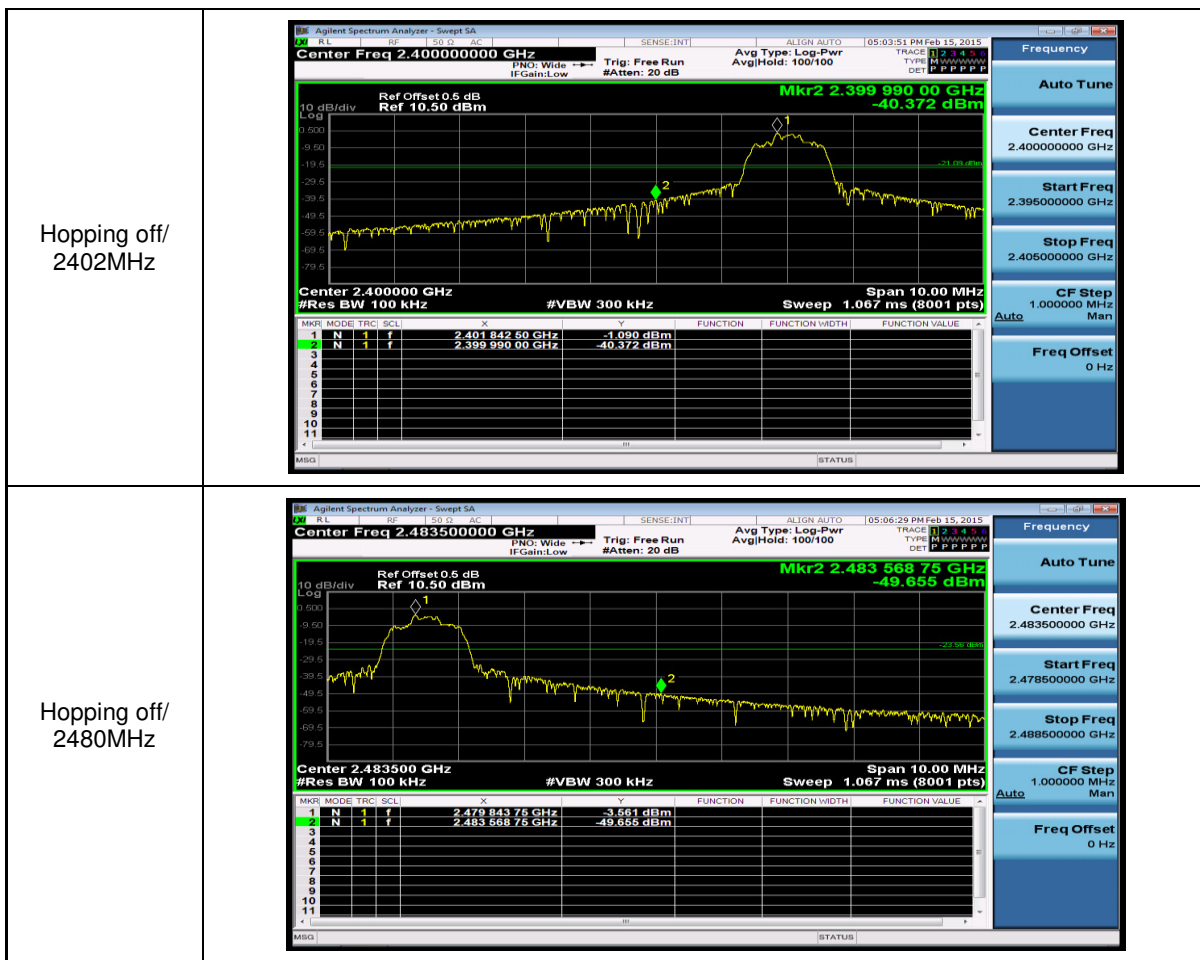

Hopping on/
2402MHz

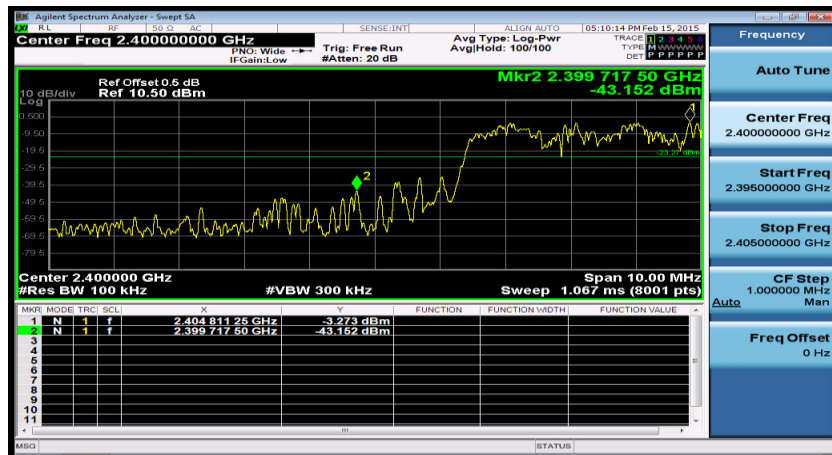

Hopping on/
2480MHz

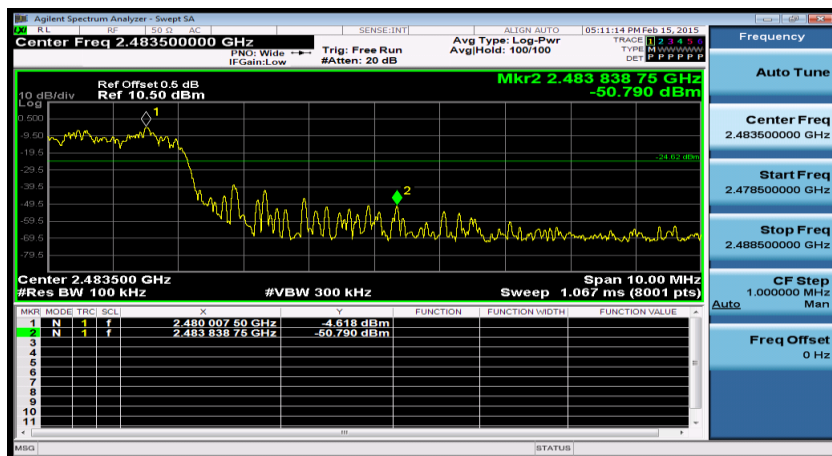

9.10 Antenna Measurement

Limit

For intentional device, according to 15.203, an intentional radiator shall be designed to ensure that no antenna other than that furnished by the responsible party shall be used with the device.

And According to 15.247 (b), if transmitting antennas of directional gain greater than 6 dBi are used, the power shall be reduced by the amount in dB that the directional gain of the antenna exceeds 6dBi.

Antenna Connector Construction

The antenna used in this product is an integrated PCB monopole antenna. And the maximum Gain of this antenna is 0.0 dBi.

Antenna Gain

	Low channel	Middle channel	High channel
Conducted power (dBm)	0.264	-0.747	-2.054
Radiated Power (dBm)	0.239	-0.735	-2.081
Gain (dBi)	-0.025	-0.012	-0.027
Measurement uncertainty	± 1.5dB(Cond.)/3dB(Rad.)		