

COMPLETE REFERENCE BILL OF MATERIALS

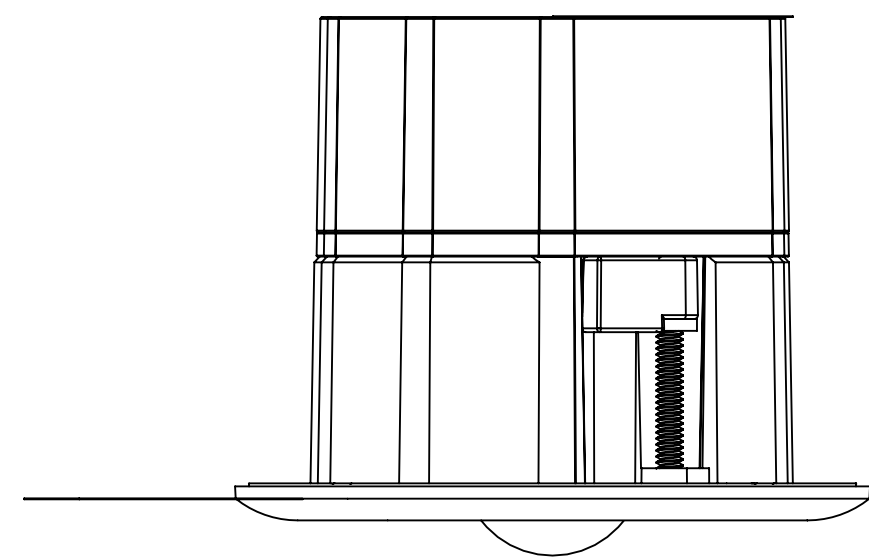
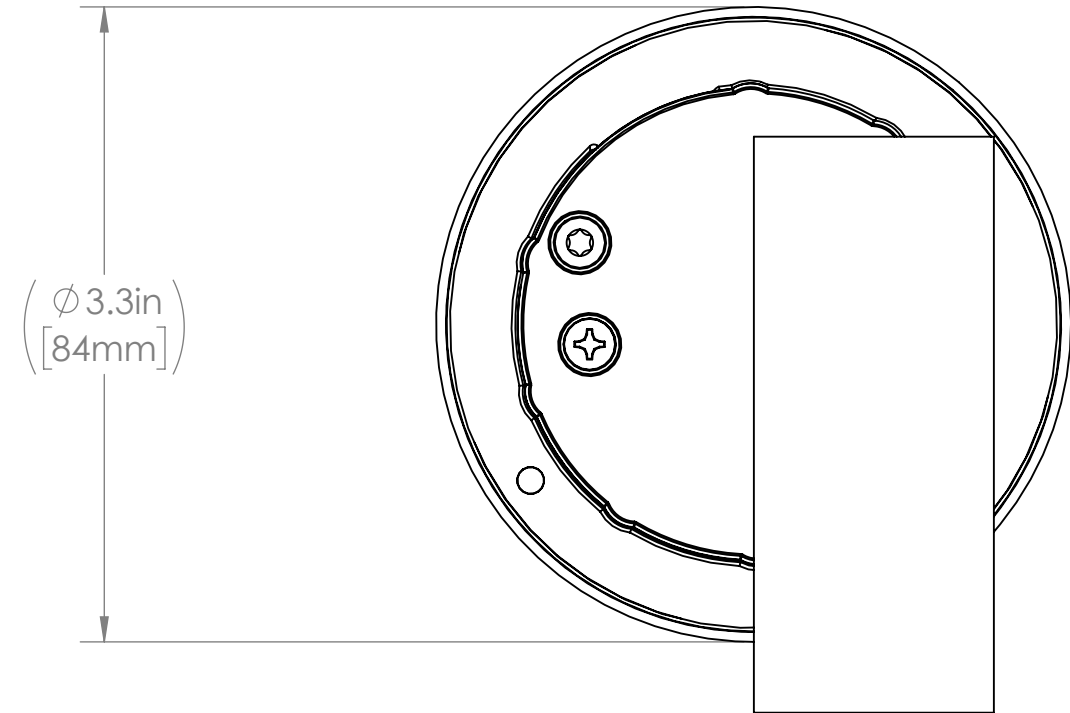
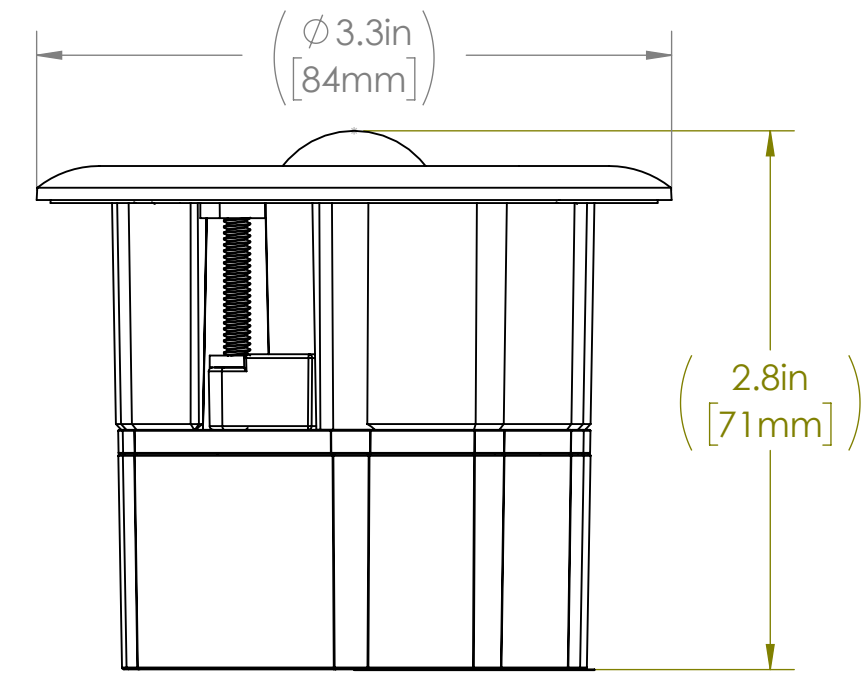

AUDACY™ LS1403
FCC ID: 2AAMXLS1403
IC: 11250A - LS1403

3.6 VOLTS

UL **us**
LISTED
 Energy Management
 Equipment
 E359679

Model VSC1300M
IDEAL INDUSTRIES, INC.

30000001

30000001

This device complies with Part 15 of the FCC Rules. Operation is subject to the following two conditions: this device may not cause harmful interference and this device must accept any interference received, including interference that may cause undesired operation.

ITEM NO.	PART NUMBER	DESCRIPTION	QTY.
1	KB-1104	BEZEL, FRONT FACIA	1
2	LB-3007	BATTERY ACTIVATION LABEL	1
3	358.070	SCREW, ZINC PLATED, #4-20 X .25", T10 DRIVE	2
4	LB-2948	LIGHT SENSOR LENS	1
5	358.068	SCREW, 6-32 THREAD SIZE, 1-1/4" LONG SLOTTED	2
6	KB-1102	LENS RETAINER/ BOARD HOUSING	1
7	5900.172	NYLON WASHER	2
8	KB-1105	LOCKING TAB	2
8.1	LB-3028	WING, CELING SECURMENT	1
8.2	LB-2988	#6-32 THREADED PLASTIC MOLDED INSERT	1
9	KB-1167	PCBA, US RECESSED LIGHT SENSOR	1
9.1	LB-3036	BARE BOARD, RECESSED LIGHT SENSOR	1
9.2	KB-9892	SUB-ASSY, LIGHT SENSOR HOLDER	1
9.2.1	KB-9890	LIGHT SENSOR HOLDER, STANDOFF	1
9.2.2	1438.002	PHOTOSENSOR	1
9.2.3	LB-2801	BLUE LENS	1
9.2.4	LB-2802	YELLOW LENS	1
10	KB-1159	PLENUM, BATTERY BOARD HOUSING	1
10.1	KB-1160	ASSEMBLY, BATTERY BOARD	1
10.1.1	LB-3015	BARE BOARD, US RECESSED BATTERY	1
10.1.2	654.104	RED WIRE, 20AWG 19/32 300V FLEXIBLE	1
10.1.3	654.105	BLACK WIRE, 20 AWG 19/32 300V FLEXIBLE	1
10.1.4	LB-3046	HEAT RESISTANT SLEEVE, ORANGE	1
10.2	KB-1103	METAL PLENUM HOUSING	1
10.3	KB-1142	PLENUM HOUSING LID	1
10.4	358.067	6-32 X 1/4" TORX SCREW	2
11	358.069	6-32 1-1/4" MACHINE SCREW	2
12	ND-8958		1

THIS BILL OF MATERIALS IS USED FOR REFERENCE ONLY. ALL PARTS SHOULD BE FOUND ON SPECIFIC ASSEMBLY DRAWINGS IN THE ACTIVE BILL OF MATERIALS SECTION AT THE TOP OF THE SHEET.

DATE		BY	ENG	EON NO.	SYM	ISS	-- PROPRIETARY DESIGN -- "CONFIDENTIAL" -- ALL DIMENSIONS IN INCHES UNLESS OTHERWISE SPECIFIED TOLERANCES UNLESS OTHERWISE SPECIFIED .00 .01 .02 .03 .04 .05 .06 .07 .08 .09 .10 .12 .15 .18 .20 .25 .30 .35 .40 .45 .50 .60 .70 .80 .90 1.00 1.25 1.50 2.00 2.50 3.00 4.00 5.00 6.00 8.00 10.00 REMOVE ALL BURRS BREAK ALL SHARP EDGES PART VOLUME CUBIC INCHES FINISH:		TITLE: ASSEMBLY, US RECESSED LIGHT SENSOR 59-LS1403 MATL: SCALE: 1:1 DRAWN BY: AJT CHECKED BY: APP BY: DATE: 7/23/2019 DRAWING NO.: IA-6271		
IDEAL INDUSTRIES, INC. SYCAMORE, ILLINOIS, U.S.A.							IDEAL				