

SERIAL ID LABEL.

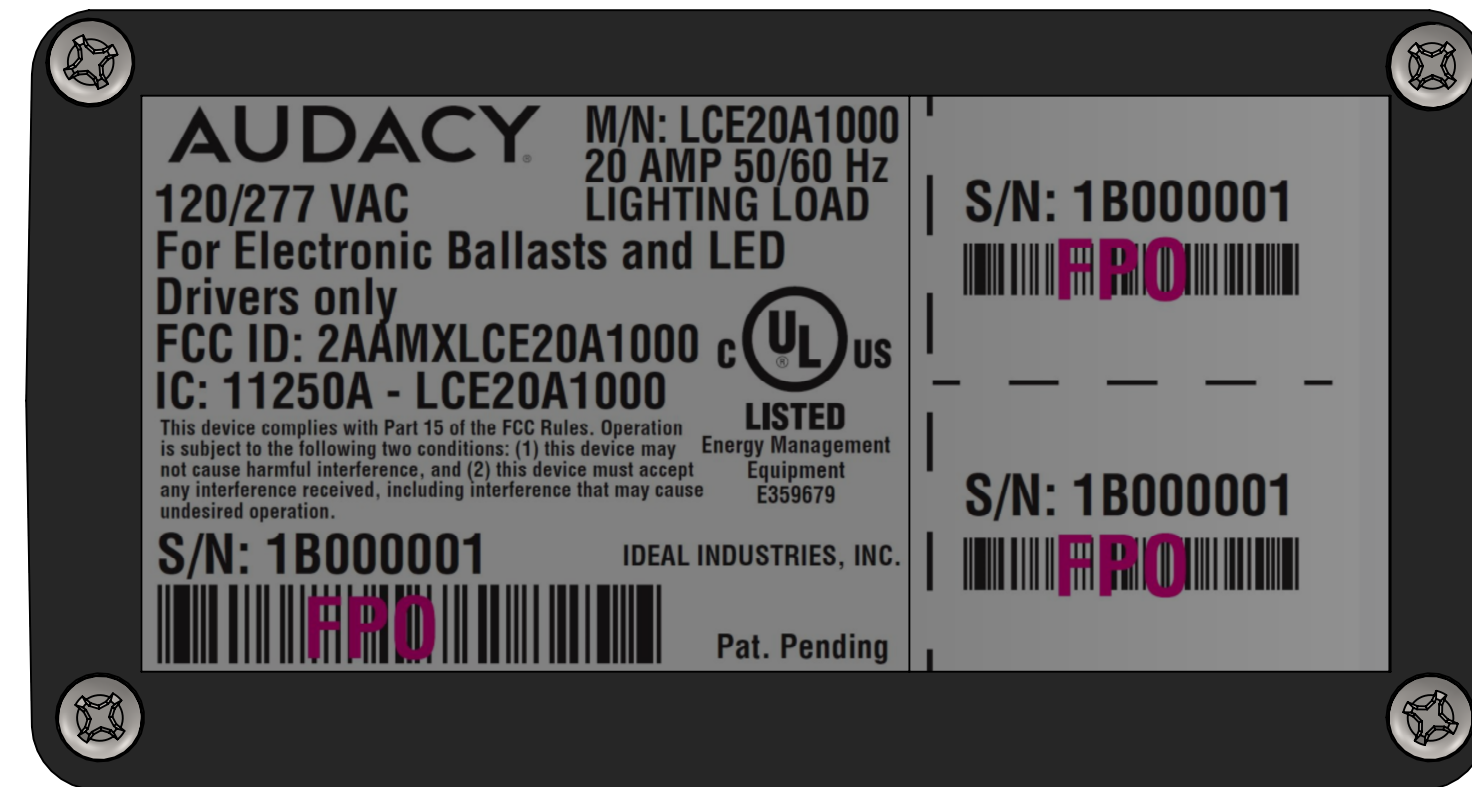
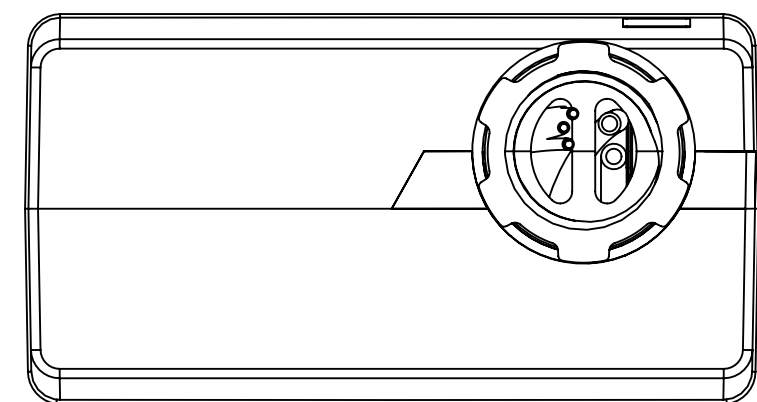
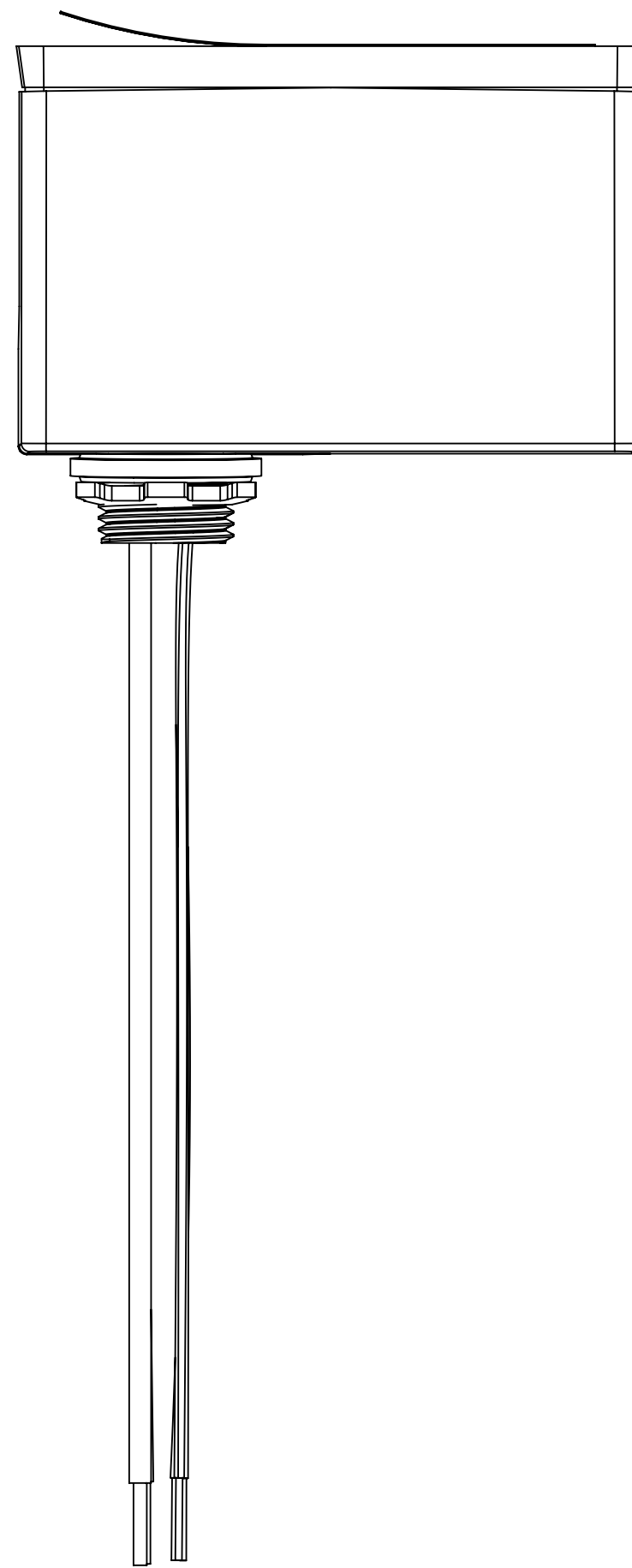
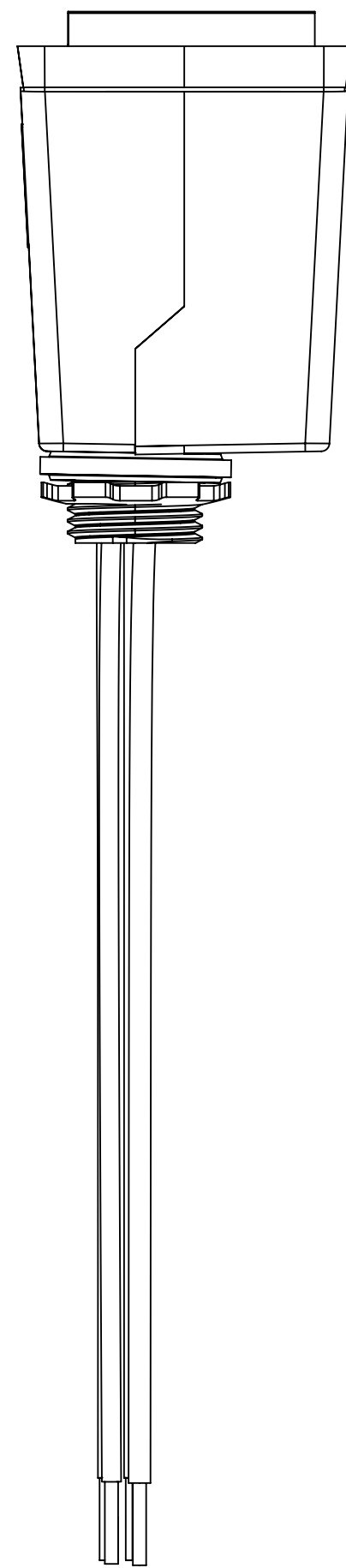
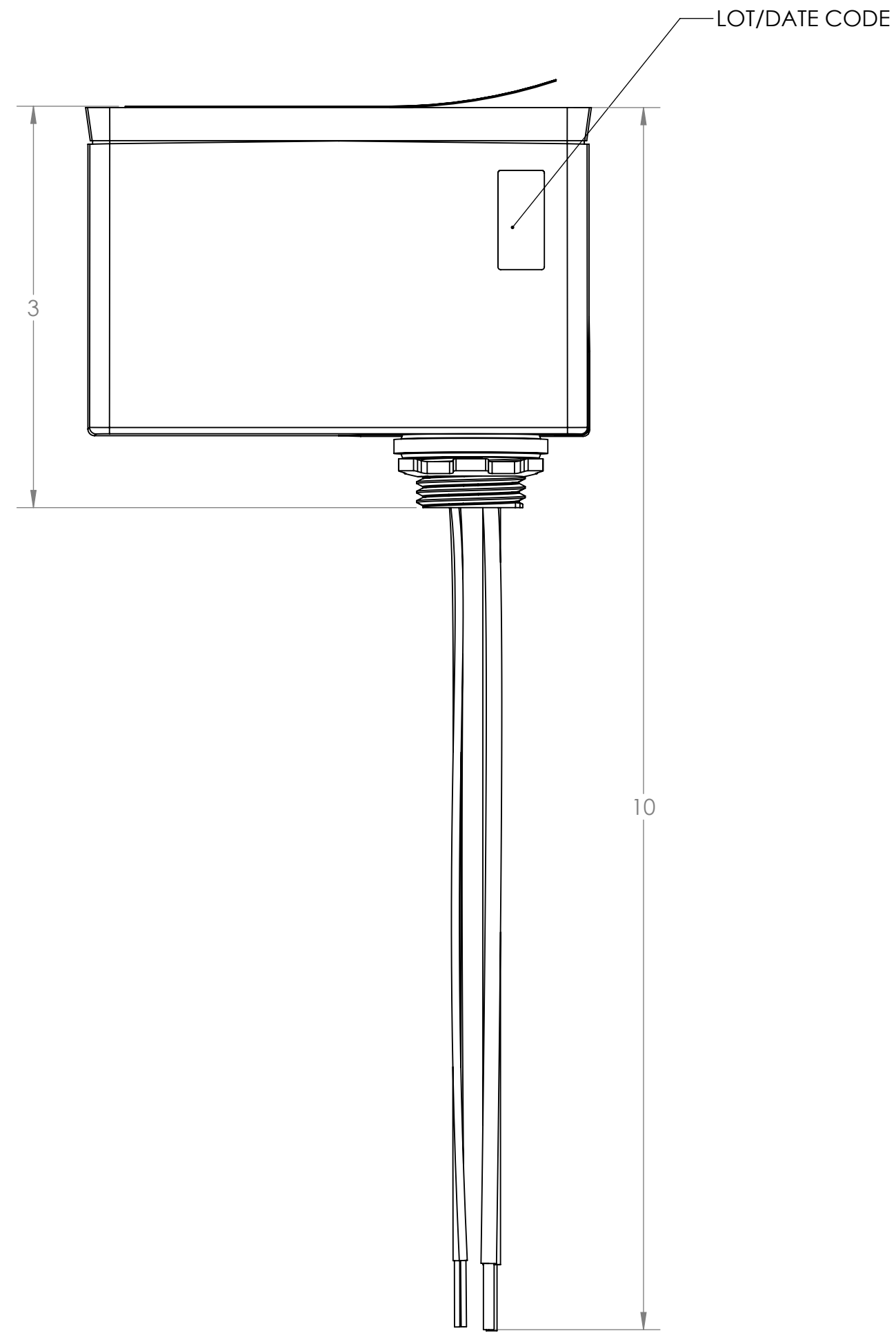

<p align="center">--- PROPRIETARY DESIGN --- CONFIDENTIAL ---</p> <p align="center">UNLESS OTHERWISE SPECIFIED:</p> <p align="center">TOLERANCES UNLESS OTHERWISE SPECIFIED</p> <p align="center">PART VOLUME</p> <p align="center">SCALE: 1:1</p> <p align="center">CUBIC INCHES</p> <p align="center">IDEAL INDUSTRIES, INC.</p> <p align="center">SYCAMORE, ILLINOIS, U.S.A.</p>										<p>TITLE:</p> <p>MATL:</p> <p>FINISH:</p> <p>SCALE: 1:1</p> <p>DATE:</p>													
DATE	BY	ENG	EON NO	SYM	ISS	DATE	BY	ENG	EON NO	SYM	ISS	DATE	BY	ENG	EON NO	SYM	ISS	DATE	BY	ENG	EON NO	SYM	ISS