

SCALE 1 : 2

NOTES:  
 1: APPLY A MINIMUM TORQUE OF 4.0 IN-LBS TO ITEM 1 FASTNER  
 2: INSERT ITEM 2 INTO THE COMPLETED PCB HOUSING FOR SHIPPING.

ITEM NO.	PART NUMBER	DESCRIPTION	QTY.
1	99512A159		1
2	182 S	182S - Male Connector	1
3	KB-9992	PCB Housing	1
4	KB-9993	Clamping Arm	1
5	LB-2879	ASSEMBLY, PCB CONTROLLER	1
6	KB-9994	Secured Cover	1
7	ND-8351	UL PRODUCT LABEL	1

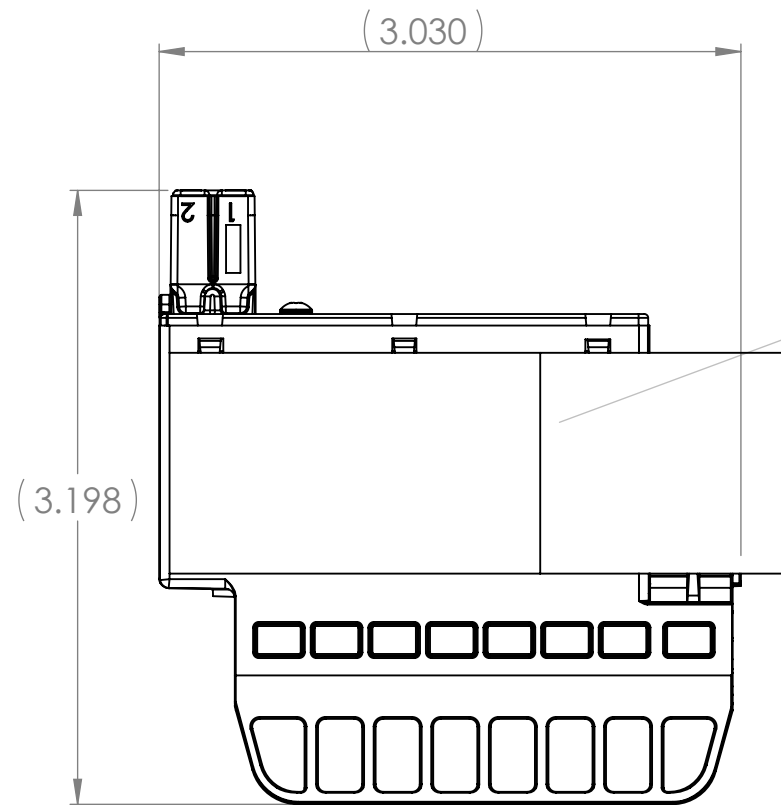
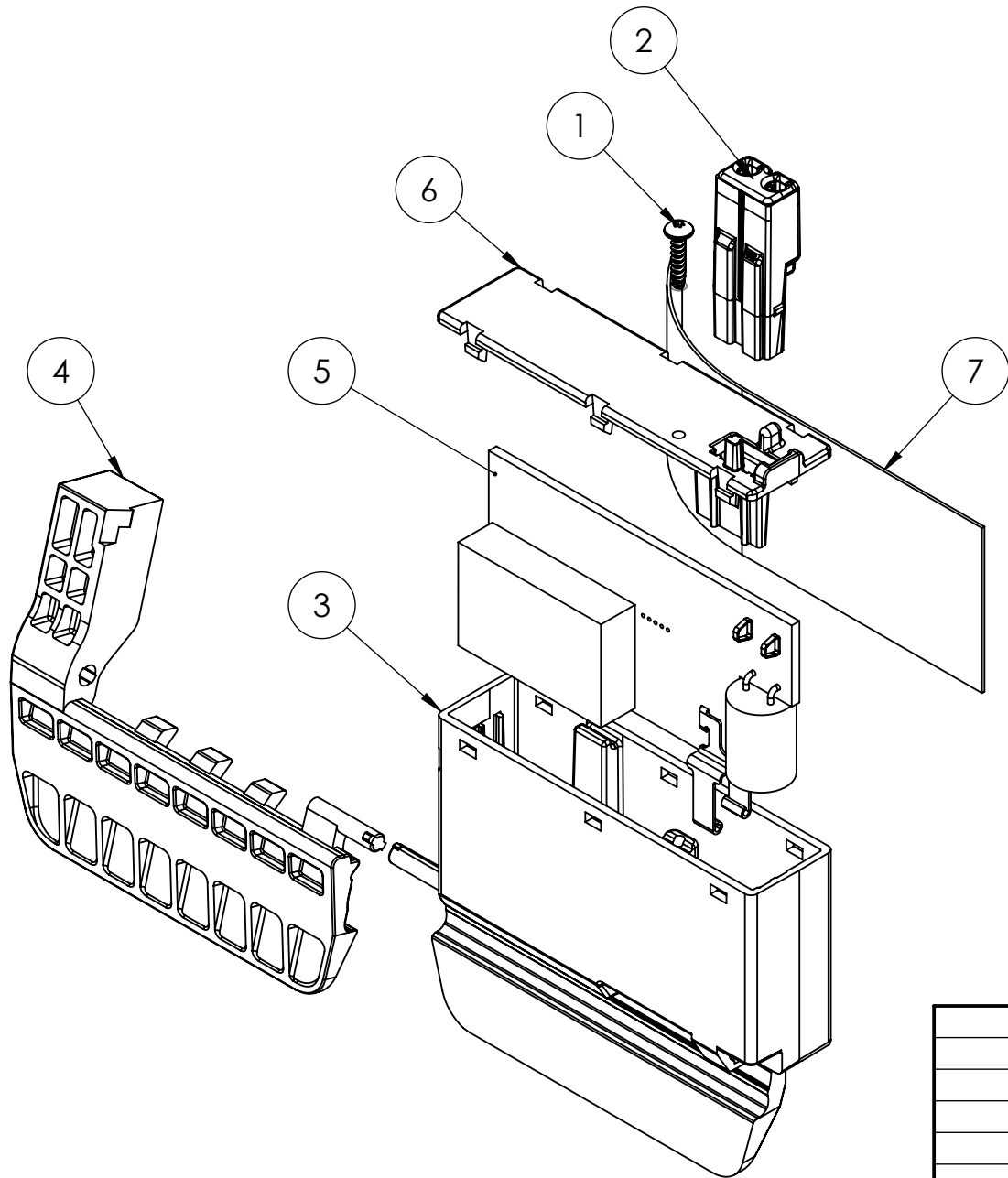

**AUDACY**™ M/N: ESCGRID1000  
 24VDC, 4.1 Amps  
 FCC ID: 2AAMXESCGRID1000  
 IC: 11250A-ESCGRID1000  
 IDEAL INDUSTRIES, INC.  
 S/N: 0E000001

**CLASSIFIED**  
  
**LISTED**  
 Suspended Ceiling  
 Grid LV Systems &  
 Equipment  
 E470836

**FPO**

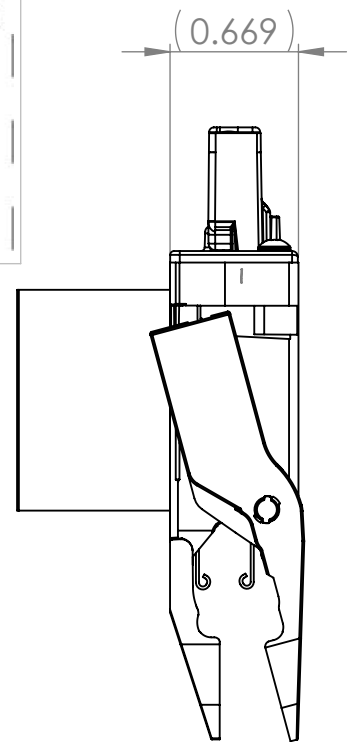

					<b>-- PROPRIETARY DESIGN - "CONFIDENTIAL" --</b> <small>ALL INFORMATION CONTAINED ON THIS DRAWING IS CONFIDENTIAL AND THE SOLE PROPERTY OF IDEAL INDUSTRIES, INC. UNAUTHORIZED COPYING OR DISTRIBUTION OF THIS DOCUMENT IS STRICTLY PROHIBITED.</small>		TITLE: ASSEMBLY, ON-GRID CONTROLLER	
					<b>-- UNLESS OTHERWISE SPECIFIED:</b> <small>THIS DRAWING BASED ON ANSI Y 14.5 SURFACE FINISH 125 ✓ ON MACHINED SURFACES. DIMENSIONS SYMMETRICAL ABOUT CENTER LINE WHERE APPLICABLE ON PLATED PARTS ALL DIMENSIONAL LIMITS APPLY AFTER PLATING DIMENSIONS OF MOLDED PARTS ARE FOR FINISHED PART. NO ALLOWANCE HAS BEEN MADE FOR SHRINK.</small>		59-ESCGRID1000	
					<b>-- HAZARDOUS SUBSTANCE CONTROL:</b> <small>ANY PRODUCT OR PART THAT CONTAINS LEAD, HEXAVALENT CHROMIUM, MERCURY, CADMIUM, POLYBROMINATED BIPHENYLS, POLYBROMINATED DIPHENYL ETHERS, PENTABROMO-DIPHENYL ETHER, OR OCTABROMO-DIPHENYL ETHER MUST BE IN FULL COMPLIANCE WITH EUROPEAN UNION 2002/95/EC &amp; 2003/11/EC DIRECTIVES.</small>		MAT'L: SEE COMPONENT MATERIALS	
					DO NOT SCALE DRAWING <small>- ALL DIMENSIONS IN INCHES.          - REMOVE ALL BURRS.          - BREAK ALL SHARP EDGES.</small>		FINISH: APPLIANCE WHITE	
					TOLERANCES UNLESS OTHERWISE SPECIFIED <small>.00 ±.02 ANGLES ±0°30'          .000 ±.005</small>		SCALE: 1:1 DRW.BY: AJT CKDBY: APP.BY:	
					PART VOLUME <b>CUBIC INCHES</b>		DATE: 6/3/2016 DRWG. NO. IA-6123	
DATE BY ENG ECN NO. SYM ISS							IDEAL INDUSTRIES, INC. SYCAMORE, ILLINOIS, U.S.A.	