

## Product Manual

### AH-CO2THD Temperature Sensor

---

#### PRODUCT DESCRIPTION

The Audacy AH-CO2THD is a battery powered device specially designed to detect the CO2/temperature/humidity and wirelessly transmit this information to the Audacy Gateway. The information provided by the sensor is used to determine if HVAC systems should be adjusted to achieve the desired environmental conditions. The product has a 25-year battery life design and will not require AC or DC line power, providing building owners and occupant placement flexibility.



#### KEY FEATURES

- FCC and IC approved
- Flexible ceiling mounting options
- 25+ year battery life
- Small form factor with internal antenna
- RoHS compliant
- Factory configurable for custom applications

#### PRODUCT CONTENTS

The following items are included inside the package:

Qty	Description
1	Temperature Sensor AH-CO2THD
1	Sensor Cradle
2	Mounting Screw
1	Locking Screw
1	Instruction card

Audacy®, Smart Connector® and Smart Switch® are registered trademarks of IDEAL INDUSTRIES.  
All other trademarks are the property of their respective owners.

# Product Manual

## AH-CO2THD Temperature Sensor

---

### SET-UP AND OPERATION

1. Place the AH-CO2THD cradle in the desired location with the optional mounting screws(2). Cradle can be mounted directly to drywall or ceiling tiles.
2. Press the button located on the bottom side of the Temperature Sensor AH-CO2THD to activate device.
3. An optional screw can be used to lock the Smart Switch in the cradle.

### SPECIFICATIONS

Item	Description
Radio	915 MHz Internal Antenna
Regulatory Approvals	FCC Part 15 and Industry Canada FCC ID: 2AAMXAHCO2THD IC: 11250A-AHCO2THD
Transmit Range	100 ft. indoors to an Audacy Gateway or Smart Connector in a typical commercial office building
Power	25+ year Li battery, non-replaceable
Operating Temperature	10°C to 32°C
Storage Temperature	-20°C to 50°C
Installation Environment	Indoor use only
Mounting	2 bracket mounting holes (See mechanical drawing for dimensions)
Color	White
Dimensions	4.56" x 2.29" x 1.5" (115.82 x 58.17 x 38.1 mm)
Weight	2.9 oz
Warranty	1 year

# Product Manual

## AH-CO2THD Temperature Sensor

# AUDACY™

ADVANCED WIRELESS SOLUTIONS BY



### MECHANICAL (REAR VIEW)

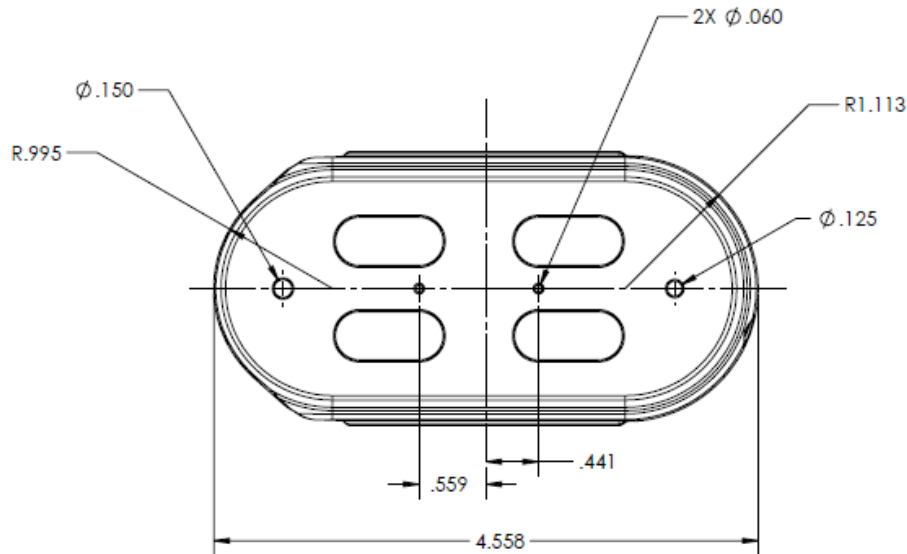

\*Dimensions in inches

### MECHANICAL (TOP VIEW)

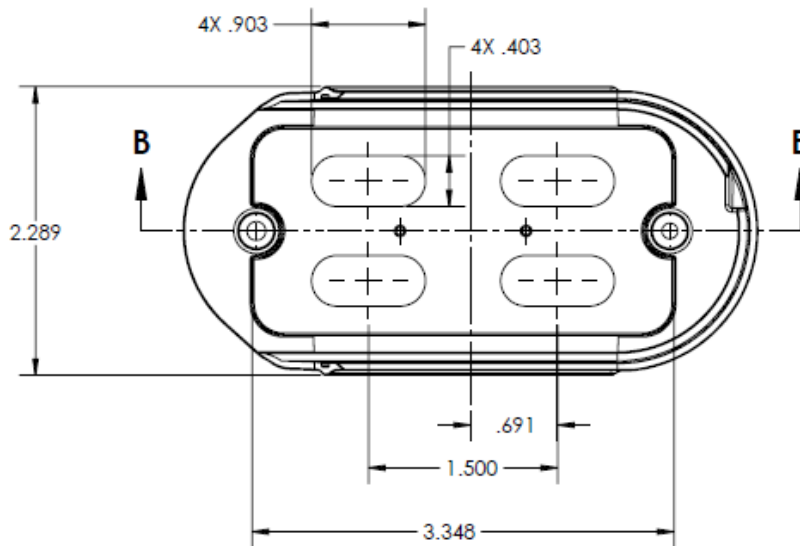

\*Dimensions in inches

# Product Manual

## AH-CO2THD Temperature Sensor

---

**AUDACY**<sup>™</sup>

ADVANCED WIRELESS SOLUTIONS BY



### SUPPORT

Technical support for IDEAL INDUSTRIES products can be initiated through the following methods:

Website: <http://www.idealindustries.com/support/>

Telephone: +1 800-435-0705

Email: [contactus@idealindustries.com](mailto:contactus@idealindustries.com)

# Product Manual

## AH-CO2THD Temperature Sensor

---

**AUDACY**<sup>™</sup>

ADVANCED WIRELESS SOLUTIONS BY



### COMPLIANCE STATEMENTS

This device is intended for commercial and industrial applications.

Changes or modifications not expressly approved by IDEAL INDUSTRIES could void the user's authority to operate the equipment. Use and maintain device only as specified in this manual.

This equipment has been tested and found to comply with the limits for a Class B digital device, pursuant to Part 15 of the FCC Rules. These limits are designed to provide reasonable protection against harmful interference in a residential installation. This equipment generates, uses, and can radiate radio frequency energy and, if not installed and used in accordance with the instructions, may cause harmful interference to radio communications. However, there is no guarantee that interference will not occur in a particular installation. If this equipment does cause harmful interference to radio or television reception, which can be determined by turning the equipment off and on, the user is encouraged to try to correct the interference by one of the following measures:

- Reorient or relocate the receiving antenna.
- Increase the separation between the equipment and receiver.
- Connect the equipment into an outlet on a circuit different from that to which the receiver is connected.
- Consult the dealer or an experienced radio/TV technician for help.

### WARNING!

#### FCC and IC Radiation Exposure Statement:

This equipment complies with FCC's and IC's RF radiation exposure limits set forth for an uncontrolled environment under the following conditions:

1. This equipment should be installed and operated such that a minimum separation distance of 20cm is maintained between the radiator (antenna) & user's/nearby person's body at all times.
2. This transmitter must not be co-located or operating in conjunction with any other antenna or transmitter.

*This device contains licence-exempt transmitter(s)/receiver(s) that comply with Innovation, Science and Economic Development Canada's licence-exempt RSS(s). Operation is subject to the following two conditions: (1) this device may not cause interference, and (2) this device must accept any interference, including interference that may cause undesired operation of the device.*

*Cet appareil contient des émetteurs / récepteurs exemptés de licence conformes aux RSS (RSS) d'Innovation, Sciences et Développement économique Canada. Le fonctionnement est soumis aux deux conditions suivantes: (1) l'appareil ne doit pas*

# Product Manual

## AH-CO2THD Temperature Sensor

---

**AUDACY**<sup>™</sup>

ADVANCED WIRELESS SOLUTIONS BY



*produire de brouillage, et (2) l'appareil doit accepter tout brouillage radioélectrique subi, même si le brouillage est susceptible d'en compromettre le fonctionnement.*

# Product Manual

## AH-CO2THD Temperature Sensor

---



### IMPORTANT NOTICE

Information furnished by IDEAL INDUSTRIES, INC. is believed to be accurate and reliable. No license, express or implied, to any intellectual property rights is granted by this document. No responsibility is assumed by IDEAL INDUSTRIES, INC. for its use, nor for any infringements of patents or other rights of third parties that may result from its use. IDEAL INDUSTRIES, INC. assumes no liability for misuse of this product. Specifications are subject to change without notice.

No license is granted by implication or otherwise under any patent or patent rights of IDEAL INDUSTRIES, INC. Trademarks and registered trademarks are the property of their respective owners.

IDEAL INDUSTRIES, INC. PRODUCTS (INCLUDING HARDWARE AND/OR SOFTWARE) ARE NOT DESIGNED OR INTENDED TO BE FAIL-SAFE, FAULT TOLERANT OR FOR USE IN ANY APPLICATION THAT COULD LEAD TO DEATH, PERSONAL INJURY OR SEVERE PROPERTY OR ENVIRONMENTAL DAMAGE (INDIVIDUALLY AND COLLECTIVELY, "CRITICAL APPLICATIONS"), SUCH AS LIFE-SUPPORT OR SAFETY DEVICES OR SYSTEMS, CLASS III MEDICAL DEVICES, NUCLEAR FACILITIES, APPLICATIONS THAT AFFECT CONTROL OF A VEHICLE OR AIRCRAFT, APPLICATIONS RELATED TO THE DEPLOYMENT OF AIRBAGS, OR ANY OTHER CRITICAL APPLICATIONS. CUSTOMER AGREES, PRIOR TO USING OR DISTRIBUTING ANY SYSTEMS THAT INCORPORATE IDEAL INDUSTRIES, INC. PRODUCTS, TO THOROUGHLY TEST THE SAME FOR SAFETY PURPOSES. CUSTOMER ASSUMES THE SOLE RISK AND LIABILITY OF ANY USE OF IDEAL INDUSTRIES, INC. PRODUCTS IN CRITICAL APPLICATIONS, SUBJECT ONLY TO APPLICABLE LAWS AND REGULATIONS GOVERNING LIMITATIONS ON PRODUCT LIABILITY.

# Product Manual

## AH-CO2THD Temperature Sensor

---

**AUDACY™**

ADVANCED WIRELESS SOLUTIONS BY



### WARRANTY

THIS LIMITED WARRANTY applies solely to standard transmitters manufactured by or on behalf of IDEAL INDUSTRIES, INC.. Subject to the limitations herein, IDEAL INDUSTRIES warrants that transmitters, when delivered by IDEAL INDUSTRIES or its authorized distributor, for one (1) year following the delivery date, will be free from defects in material and workmanship and will substantially conform to IDEAL INDUSTRIES publicly available specifications for such products in effect at the time of delivery. This limited warranty excludes: (i) engineering samples (which are provided “AS-IS” without warranty); (ii) bare circuit boards (iii) development products (such as boards and cables); (iv) design defects or errors known as “errata”; (v) transmitters procured through unauthorized third parties; and (vi) transmitters that have been subject to misuse, mishandling, accident, alteration, neglect, unauthorized repair or installation. Furthermore, this limited warranty shall not apply to the use of covered products in an application or environment that is not within IDEAL INDUSTRIES specifications or in the event of any act, error, neglect or default of Customer. If such IDEAL INDUSTRIES products fail to conform to the warranty above, the exclusive remedy of Customer and the sole liability of IDEAL INDUSTRIES shall be, at the option of IDEAL INDUSTRIES, to replace or repair the affected products, or to refund to Customer the price of the affected products. The availability of replacement products is subject to product discontinuance policies at IDEAL INDUSTRIES. Customer may not return products without first obtaining a customer return material authorization (RMA) number from IDEAL INDUSTRIES. THE WARRANTIES SET FORTH HEREIN ARE EXCLUSIVE AND IN LIEU OF ALL OTHER WARRANTIES, REMEDIES AND CONDITIONS, WHETHER ORAL OR WRITTEN, EXPRESS OR IMPLIED. IDEAL INDUSTRIES DISCLAIMS ALL OTHER WARRANTIES, WHETHER EXPRESS, IMPLIED OR STATUTORY, INCLUDING, WITHOUT LIMITATION, ANY WARRANTY OF MERCHANTABILITY, FITNESS FOR A PARTICULAR PURPOSE, OR NON-INFRINGEMENT, AND ANY WARRANTY THAT MAY ARISE FROM COURSE OF DEALING, COURSE OF PERFORMANCE, OR USAGE OF TRADE. IF IDEAL INDUSTRIES CANNOT LAWFULLY DISCLAIM IMPLIED WARRANTIES UNDER THIS LIMITED PRODUCT WARRANTY, ALL SUCH IMPLIED WARRANTIES, INCLUDING WARRANTIES OF MERCHANTABILITY AND FITNESS FOR A PARTICULAR PURPOSE, ARE LIMITED IN DURATION TO THE WARRANTY PERIOD (AS DEFINED ABOVE). YOUR SOLE REMEDY WITH RESPECT TO ANY BREACH OF THE LIMITED PRODUCT WARRANTY SHALL BE THE REPAIR OR REPLACEMENT OF THE DEVICE AS SPECIFIED IN THE LIMITED PRODUCT WARRANTY. IDEAL INDUSTRIES IS NOT RESPONSIBLE FOR DIRECT, SPECIAL, INCIDENTAL, OR CONSEQUENTIAL DAMAGES RESULTING FROM ANY BREACH OF WARRANTY OR UNDER ANY OTHER LEGAL THEORY INCLUDING, BUT NOT LIMITED TO, LOST PROFITS, DOWNTIME, GOODWILL, DAMAGE TO OR REPLACEMENT OF EQUIPMENT AND PROPERTY, AND ANY COSTS OF RECOVERING, REPROGRAMMING, OR REPRODUCING ANY PROGRAM OR DATA STORED IN OR USED WITH A SYSTEM CONTAINING IDEAL INDUSTRIES TRANSMITTERS. Some states do not allow the exclusion or limitation of incidental or consequential damages or exclusions or limitations on the duration of implied warranties or conditions, so the above limitations or exclusions may not apply to you. This limited product warranty gives you specific legal rights, and you may also have other legal rights which vary from state to state.