FCC Test Report

Report No.: AGC00761130701EF02

FCC ID : 2AAM5TPC7026C
APPLICATION PURPOSE : Original Equipment
PRODUCT DESIGNATION : 7 Inch Tablet PC
BRAND NAME : BRILLIANT PAD
MODEL NAME : TPC7026C , M706
CLIENT : EVERBRILLIANT ENTERPRISE LIMITED
DATE OF ISSUE : Jul17,2013
STANDARD(S) : FCC Part 15 Rules
REPORT VERSION : V1.0

Attestation of Global Compliance (Shenzhen) Co., Ltd

CAUTION:

This report shall not be reproduced except in full without the written permission of the test laboratory and shall not be quoted out of context.

Report Revise Record

Report Version	Revise Time	Issued Date	Valid Version	Notes
V1.0	/	Jul.17,2013	Valid	Original Report

TABLE OF CONTENTS

1. VERIFICATION OF CONFORMITY	5
2. GENERAL INFORMATION	6
2.1. PRODUCT DESCRIPTION.....	6
2.2. TABLE OF CARRIER FREQUENCIES.....	6
2.3. IEEE 802.11N MODULATION SCHEME	7
2.4. RELATED SUBMITTAL(S) / GRANT (S).....	7
2.5. TEST METHODOLOGY.....	7
2.6. SPECIAL ACCESSORIES	7
2.7. EQUIPMENT MODIFICATIONS	7
3. MEASUREMENT UNCERTAINTY.....	8
4. DESCRIPTION OF TEST MODES.....	8
5. SYSTEM TEST CONFIGURATION	9
5.1. CONFIGURATION OF EUT SYSTEM	9
5.2. EQUIPMENT USED IN EUT SYSTEM	9
5.3. SUMMARY OF TEST RESULTS	9
6. TEST FACILITY	10
7. PEAK OUTPUT POWER	11
7.1. MEASUREMENT PROCEDURE	11
7.2. TEST SET-UP (BLOCK DIAGRAM OF CONFIGURATION).....	11
8. 6DB BANDWIDTH	13
8.1. MEASUREMENT PROCEDURE	13
8.2. TEST SET-UP (BLOCK DIAGRAM OF CONFIGURATION).....	13
8.3. LIMITS AND MEASUREMENT RESULTS.....	14
9. CONDUCTED SPURIOUS EMISSION	20
9.1. MEASUREMENT PROCEDURE	20
9.2. TEST SET-UP (BLOCK DIAGRAM OF CONFIGURATION).....	20
9.3. MEASUREMENT EQUIPMENT USED.....	20
9.4. LIMITS AND MEASUREMENT RESULT	20
10. MAXIMUM CONDUCTED OUTPUT POWER SPECTRAL DENSITY	23
10.1 MEASUREMENT PROCEDURE	23
10.2 TEST SET-UP (BLOCK DIAGRAM OF CONFIGURATION).....	23
10.3 MEASUREMENT EQUIPMENT USED.....	23
10.4 LIMITS AND MEASUREMENT RESULT	23
11. RADIATED EMISSION	30

11.1. MEASUREMENT PROCEDURE	30
11.2. TEST SETUP	31
11.3. LIMITS AND MEASUREMENT RESULT	32
11.4. TEST RESULT	32
12. BAND EDGE EMISSION	41
12.1. MEASUREMENT PROCEDURE	41
12.2. TEST SET-UP	41
12.3. TEST RESULT	42
13. FCC LINE CONDUCTED EMISSION TEST	46
13.1. LIMITS OF LINE CONDUCTED EMISSION TEST	46
13.2. BLOCK DIAGRAM OF LINE CONDUCTED EMISSION TEST	46
13.3. PRELIMINARY PROCEDURE OF LINE CONDUCTED EMISSION TEST	47
13.4. FINAL PROCEDURE OF LINE CONDUCTED EMISSION TEST	47
13.5. TEST RESULT OF LINE CONDUCTED EMISSION TEST	48
APPENDIX A: PHOTOGRAPHS OF TEST SETUP	50
APPENDIX B: PHOTOGRAPHS OF EUT	52

1. VERIFICATION OF CONFORMITY

Applicant	EVERBRILLIANT ENTERPRISE LIMITED
Address	ROOM 1701-2, 17/F., ING TOWER, 308 DES VOEUX ROAD, CENTRAL, HONG KONG
Manufacturer	Prosper Electronics (Shenzhen) Co., Ltd.
Address	3 rd Industry Zone, Xinqiao Shajing, Bao'An District, Shenzhen City, China
Product Designation	7 Inch Tablet PC
Brand Name	BRILLIANT PAD
Test Model	TPC7026C
Series Model	M706
Difference description	All the same except for the model name.
Date of test	Jul.11~ Jul.16,2013
Deviation	None
Condition of Test Sample	Normal
Report Template	AGCRT-US-BGN/RF (2013-03-01)

We hereby certify that:

The above equipment was tested by Attestation of Global Compliance (Shenzhen) Co., Ltd. The test data, data evaluation, test procedures, and equipment configurations shown in this report were made in accordance with the procedures given in ANSI C63.4 (2003) and the energy emitted by the sample EUT tested as described in this report is in compliance with requirement of FCC Part 15 Rules requirement.

Prepared By

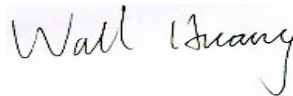

Wall Huang Jul.17,2013

Checked By



Forrest Lei Jul.17,2013

Authorized By



Solger Zhang Jul.17,2013

2. GENERAL INFORMATION

2.1. PRODUCT DESCRIPTION

The EUT is designed as a "Wifi Device". It is designed by way of utilizing the DSSS and OFDM technology to achieve the system operation.

A major technical description of EUT is described as following

Operation Frequency	2.412 GHz~2.462GHz
Max. Output Power	IEEE 802.11b:10.41Bm, IEEE 802.11g:11.96Bm IEEE 802.11n(20):10.23dBm,
Modulation	DSSS(DBPSK/DQPSK/CCK);OFDM(BPSK/QPSK/16-QAM/64-QAM)
Number of channels	11
Antenna Designation	Integrated Antenna
Antenna Gain	1.0dBi
Power Supply	DC 3.7V by Battery
Hot Spot mode	<input type="checkbox"/> Y <input checked="" type="checkbox"/> N/A

2.2. TABLE OF CARRIER FREQUENCIES

Frequency Band	Channel Number	Frequency
2400~2483.5MHZ	1	2412 MHZ
	2	2417 MHZ
	3	2422 MHZ
	4	2427 MHZ
	5	2432 MHZ
	6	2437 MHZ
	7	2442 MHZ
	8	2447 MHZ
	9	2452 MHZ
	10	2457 MHZ
	11	2462 MHZ

Note: For 20MHZ bandwidth system use Channel 1 to Channel 11

2.3. IEEE 802.11N MODULATION SCHEME

MCS Index	Nss	Modulation	R	NBPSK	Data rate(Mbps)		
					800nsGI		
					20MHz	20MHz	20MHz
0	1	BPSK	1/2	1	52	26	6.5
1	1	QPSK	1/2	2	104	52	13.0
2	1	QPSK	3/4	2	104	78	19.5
3	1	16-QAM	1/2	4	208	104	26.0
4	1	16-QAM	3/4	4	208	156	39.0
5	1	64-QAM	2/3	6	312	208	52.0
6	1	64-QAM	3/4	6	312	234	58.5
7	1	64-QAM	5/6	6	312	260	65.0

Symbol	Explanation
NSS	Number of spatial streams
R	Code rate
NBPSK	Number of coded bits per single carrier
NCBPS	Number of coded bits per symbol
NDBPS	Number of data bits per symbol
GI	Guard interval

2.4. RELATED SUBMITTAL(S) / GRANT (S)

This submittal(s) (test report) is intended for **FCC ID: 2AAM5TPC7026C** filing to comply with the FCC Part 15 requirements.

2.5. TEST METHODOLOGY

Because the EUT received power from DC3.7V lithium battery, so only radiated testing was performed according to the procedures in ANSI C63.4 (2003). Radiated testing was performed at an antenna to EUT distance 3 meters.

2.6. SPECIAL ACCESSORIES

Refer to section 5.2.

2.7. EQUIPMENT MODIFICATIONS

Not available for this EUT intended for grant.

3. MEASUREMENT UNCERTAINTY

Conducted measurement: +/- 2.75dB

Radiated measurement: +/- 3.2dB

4. DESCRIPTION OF TEST MODES

TEST MODE DESCRIPTION	
NO.	TEST MODE DESCRIPTION
1	Low channel TX
2	Middle channel TX
3	High channel TX
4	Normal operating

Note:
1. All the test modes can be supply by Built-in Li-ion battery and adapter, only the result of the worst case was recorded in the report.
2.. Transmit by 802.11b with Date rate (1/2/5.5/11)
Transmit by 802.11g with Date rate (6/9/12/18/24/36/48/54)
Transmit by 802.11n (20MHz) with Date rate (6.5/13/19.5/26/39/52/58.5/65)

Note:

1. The EUT has been set to operate continuously on the lowest, middle and highest operation frequency individually.
2. All modes under which configure applicable have been tested and the worst mode test data recording in the test report.
3. For Radiated Emission, 3axis were chosen for testing for each applicable mode.

5. SYSTEM TEST CONFIGURATION

5.1. CONFIGURATION OF EUT SYSTEM

Configure1: Normal Operating

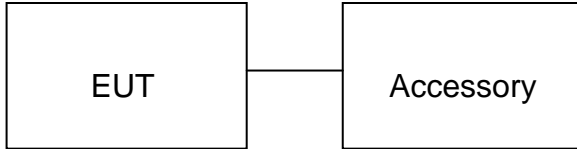

Configure 2: Control continuous TX

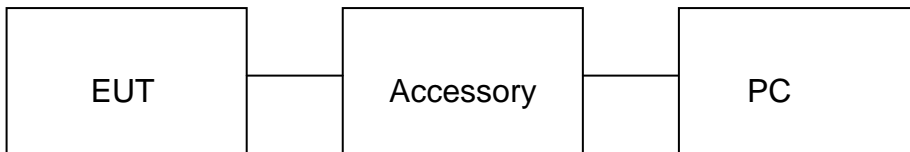

5.2. EQUIPMENT USED IN EUT SYSTEM

Item	Equipment	Mfr/Brand	Model/Type No.	Remark
1	7 Inch Tablet PC	BRILLIANT PAD	TPC7026C	EUT
2	Battery	N/A	3570100	Accessory
3	Adapter	RS, JHS	RS-E2000	Accessory
4	PC	Dell	INSPIRON	A.E

Note: All the accessories have been used during the test except for the earphone in conduction emission test.

5.3. SUMMARY OF TEST RESULTS

FCC RULES	DESCRIPTION OF TEST	RESULT
§15.247	Peak Output Power	Compliant
§15.247	6 dB Bandwidth	Compliant
§15.247	Conducted Spurious Emission	Compliant
§15.247	Maximum Conducted Output Power SPECTRAL Density	Compliant
§15.209	Radiated Emission	Compliant
§15.247	Band Edges	Compliant
§15.207	Line Conduction Emission	Compliant

Note: The EUT received power from DC3.7V lithium battery.

6. TEST FACILITY

Site	Attestation of Global Compliance (Shenzhen) Co., Ltd
Location	2/F., Building 2, No.1-No.4, Chaxi Sanwei Technical Industrial Park, Gushu, Xixiang, Bao'an District, Shenzhen, Guangdong, China
Description	The test site is constructed and calibrated to meet the FCC requirements in documents ANSI C63.4:2003.

ALL TEST EQUIPMENT LIST

Description	Manufacturer	Model	S/N	Cal. Date	Cal. Due
Power Probe	R&S	NRP-Z23	100323	07/18/2012	07/17/2013
RF attenuator	N/A	RFA20db	68	N/A	N/A
Spectrum Analyzer	Agilent	E4440A	US41421290	07/18/2012	07/17/2013
Amplifier	EM	EM30180	0607030	07/18/2012	07/17/2013
Horn Antenna	EM	EM-AH-10180	67	04/21/2013	04/20/2014
Horn Antenna	A.H. Systems Inc.	SAS-574	--	07/18/2012	07/17/2013
EMI Test Receiver	Rohde & Schwarz	ESCI	100694	07/18/2012	07/17/2013
Biological Antenna	A.H. Systems Inc.	SAS-521-4	26	06/08/2013	06/09/2014
Loop Antenna	A.H.	SAS-526B	264	07/18/2012	07/17/2013

7. PEAK OUTPUT POWER

7.1. MEASUREMENT PROCEDURE

For peak power test:

1. The EUT was placed on a turn table which is 0.8m above ground plane.
2. Connect EUT RF output port to the Spectrum Analyzer through an RF attenuator
3. Set the EUT Work on the top, middle and the bottom operation frequency individually.
4. Set the RBW greater than 6DB bandwidth of emission.
5. Record the maximum power from the Spectrum Analyzer.

For average power test:

1. The EUT was placed on a table which is 0.8m above ground plane.
2. Connect EUT RF output port to power probe through an RF attenuator.
3. Connect the power probe to the PC.
4. Set the EUT Work on the top, the middle and the bottom operation frequency individually.
5. Record the maximum power from the software.
6. The maximum peak power shall be less 1 Watt (30dBm).

Note : The EUT was tested according to KDB 558074 for compliance to FCC 47CFR 15.247 requirements.

7.2. TEST SET-UP (BLOCK DIAGRAM OF CONFIGURATION)

PEAK POWER TEST SETUP

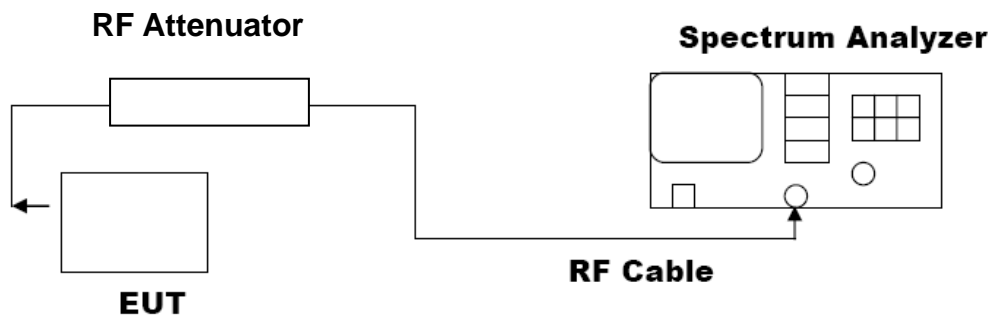

AVERAGE POWER SETUP

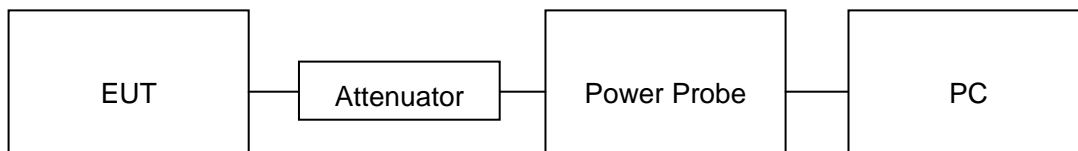

7.3. LIMITS AND MEASUREMENT RESULT

TEST ITEM	PEAK POWER
TEST MODE	802.11b with data rate 1

LIMITS AND MEASUREMENT RESULT				
Frequency (GHz)	Average Power (dBm)	Peak Power (dBm)	Applicable Limits (dBm)	Pass or Fail
2.412	8.19	10.23	30	Pass
2.437	8.25	10.29	30	Pass
2.462	8.36	10.41	30	Pass

TEST ITEM	PEAK POWER
TEST MODE	802.11g with data rate 6

LIMITS AND MEASUREMENT RESULT				
Frequency (GHz)	Average Power (dBm)	Peak Power (dBm)	Applicable Limits (dBm)	Pass or Fail
2.412	9.86	11.89	30	Pass
2.437	9.88	11.92	30	Pass
2.462	9.93	11.96	30	Pass

TEST ITEM	PEAK POWER
TEST MODE	802.11n 20 with data rate 6.5

LIMITS AND MEASUREMENT RESULT				
Frequency (GHz)	Average Power (dBm)	Peak Power (dBm)	Applicable Limits (dBm)	Pass or Fail
2.412	8.14	10.18	30	Pass
2.437	8.18	10.23	30	Pass
2.462	8.24	10.28	30	Pass

8. 6DB BANDWIDTH

8.1. MEASUREMENT PROCEDURE

1. The EUT was placed on a table which is 0.8m above ground plane.
2. Connect EUT RF output port to the Spectrum Analyzer through an RF attenuator
3. Set the EUT Work on the top, the middle and the bottom operation frequency individually.
4. Set SPA Centre Frequency = Operation Frequency, RBW= 100 KHz, VBW \geq RBW.
5. Set SPA Trace 1 Max hold, then View.

Note: The EUT was tested according to KDB 558074 for compliance to FCC 47CFR 15.247 requirements.

8.2. TEST SET-UP (BLOCK DIAGRAM OF CONFIGURATION)

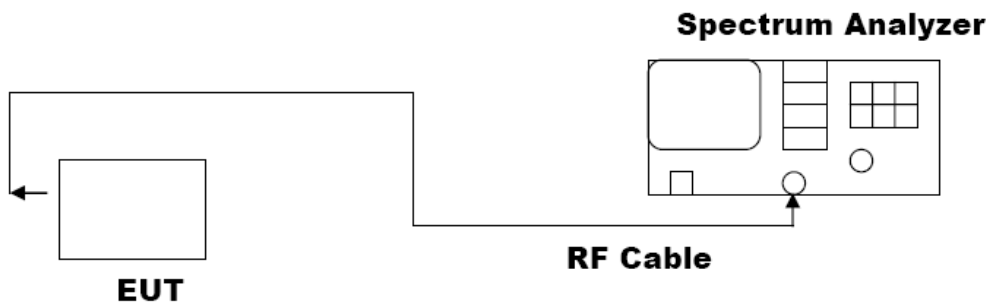

8.3. LIMITS AND MEASUREMENT RESULTS

TEST ITEM	6DB BANDWIDTH
TEST MODE	802.11b with data rate 11

LIMITS AND MEASUREMENT RESULT			
Applicable Limits	Applicable Limits		
	Test Data (MHz)		Criteria
>500KHZ	Low Channel	9.077	PASS
	Middle Channel	9.111	PASS
	High Channel	9.073	PASS

TEST ITEM	6DB BANDWIDTH
TEST MODE	802.11g with data rate 54

LIMITS AND MEASUREMENT RESULT			
Applicable Limits	Applicable Limits		
	Test Data (MHz)		Criteria
>500KHZ	Low Channel	16.391	PASS
	Middle Channel	16.404	PASS
	High Channel	16.437	PASS

TEST ITEM	6DB BANDWIDTH
TEST MODE	802.11n 20 with data rate 65

LIMITS AND MEASUREMENT RESULT			
Applicable Limits	Applicable Limits		
	Test Data (MHz)		Criteria
>500KHZ	Low Channel	17.637	PASS
	Middle Channel	17.679	PASS
	High Channel	17.654	PASS

802.11b TEST RESULT
TEST PLOT OF BANDWIDTH FOR LOW CHANNEL

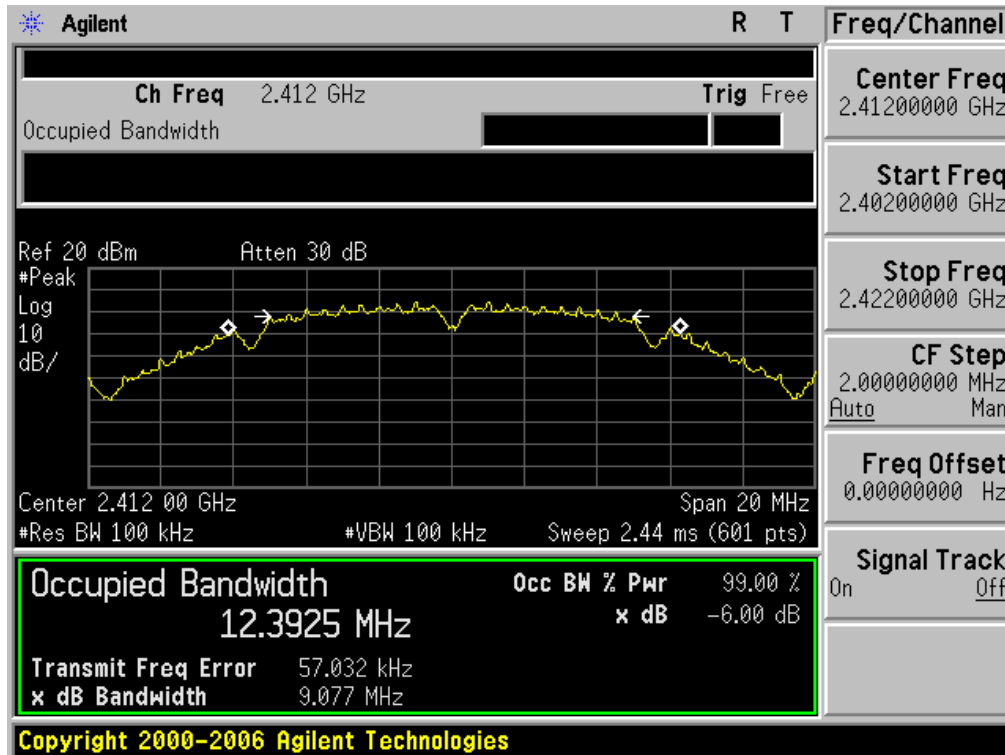

TEST PLOT OF BANDWIDTH FOR MIDDLE CHANNEL

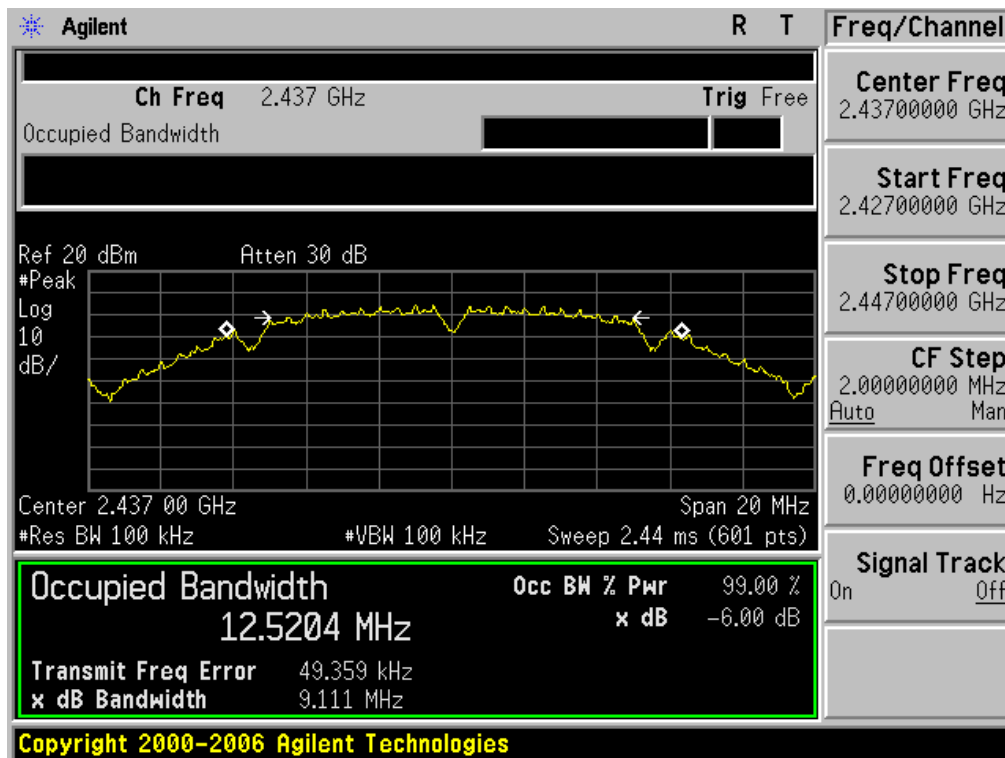

TEST PLOT OF BANDWIDTH FOR HIGH CHANNEL

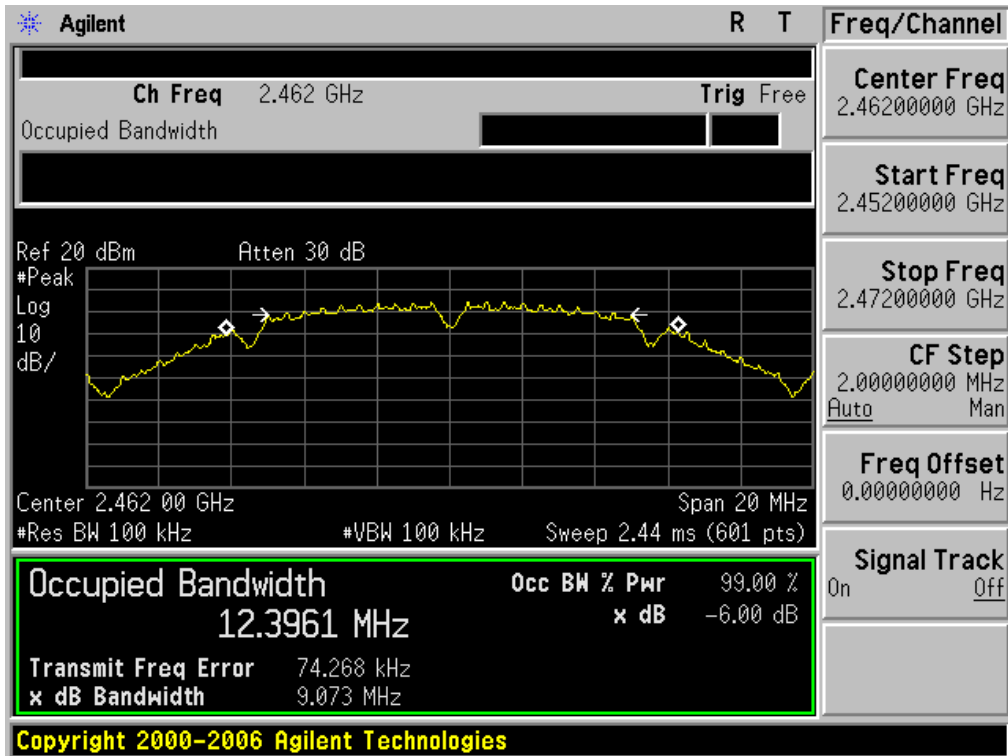

802.11g TEST RESULT

TEST PLOT OF BANDWIDTH FOR LOW CHANNEL

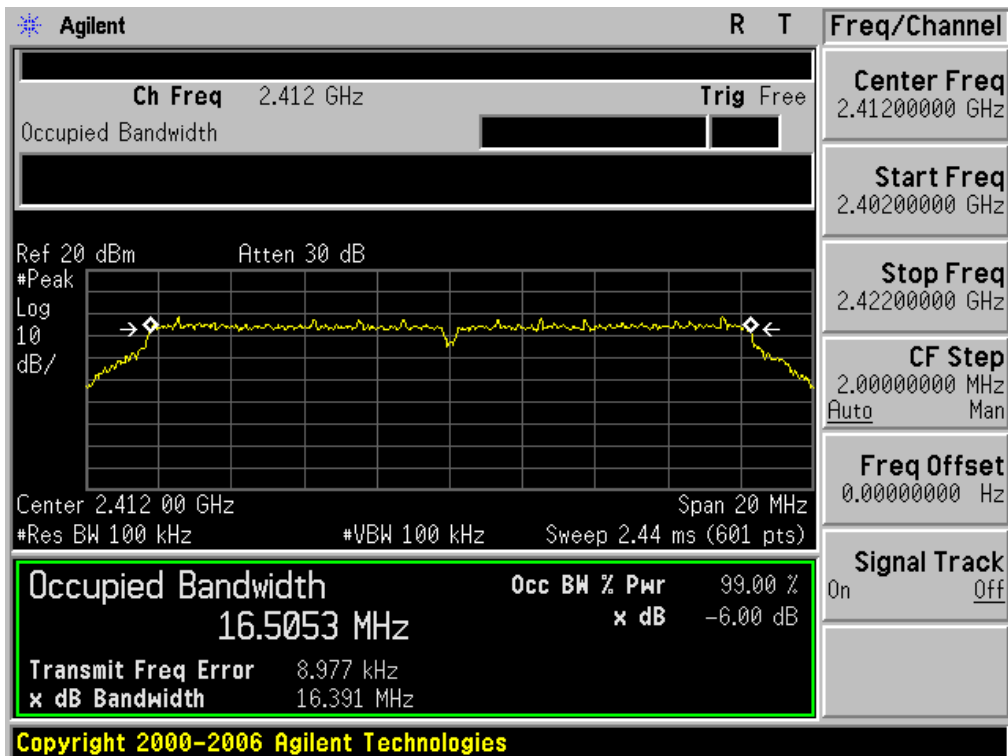

TEST PLOT OF BANDWIDTH FOR MIDDLE CHANNEL

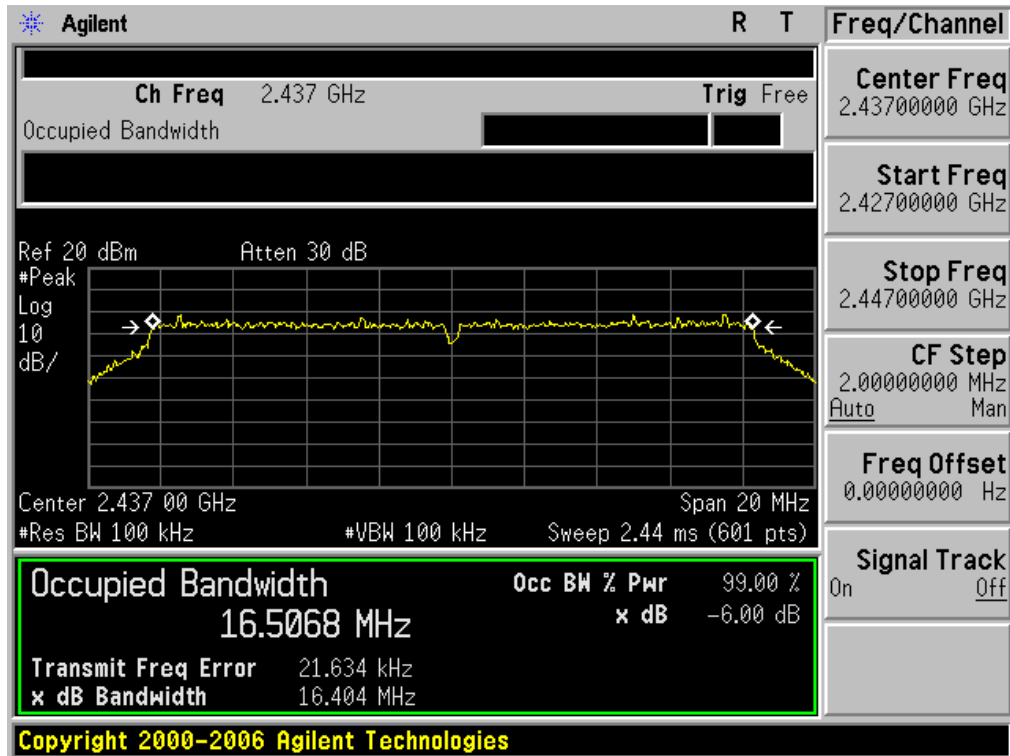

TEST PLOT OF BANDWIDTH FOR HIGH CHANNEL

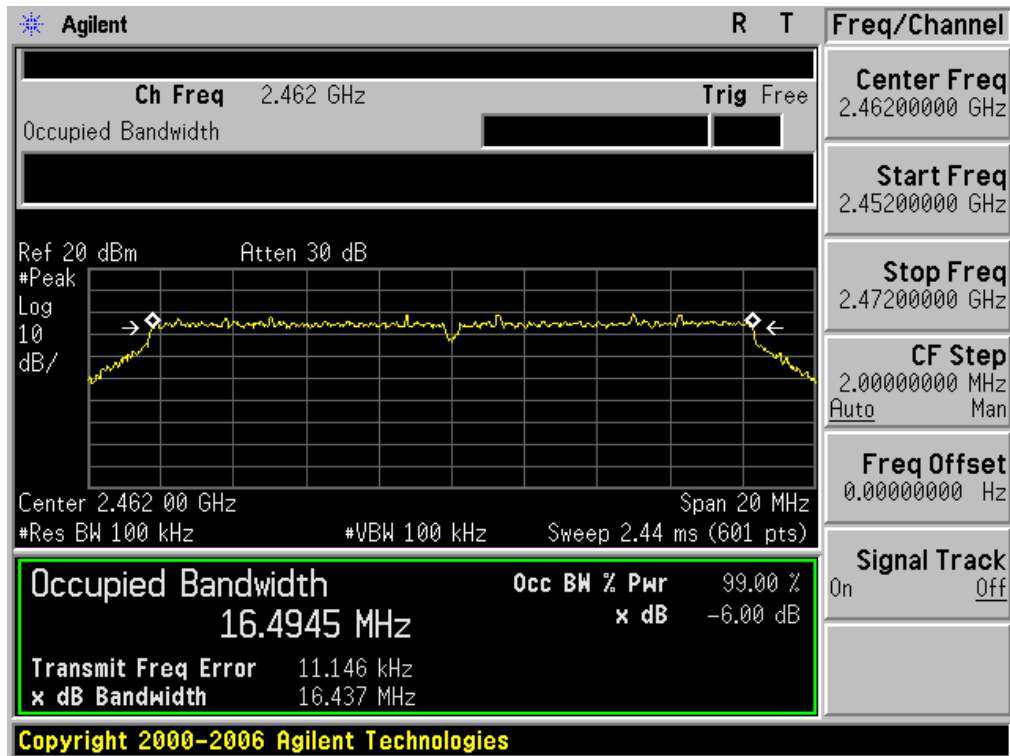

802.11n(20) TEST RESULT

TEST PLOT OF BANDWIDTH FOR LOW CHANNEL

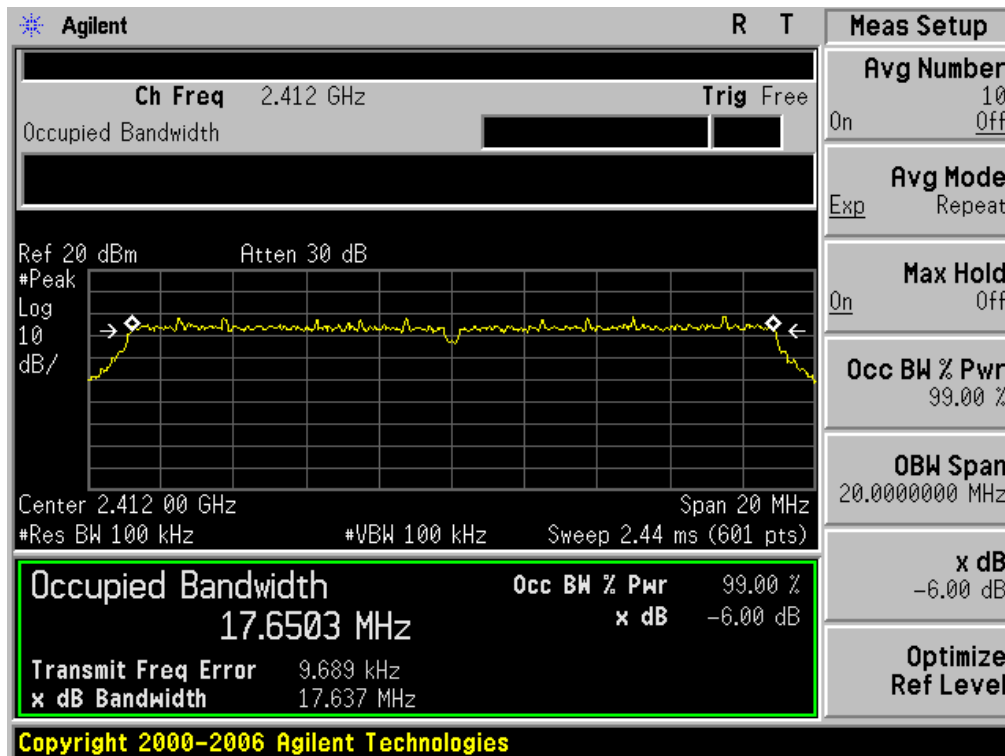

TEST PLOT OF BANDWIDTH FOR MIDDLE CHANNEL

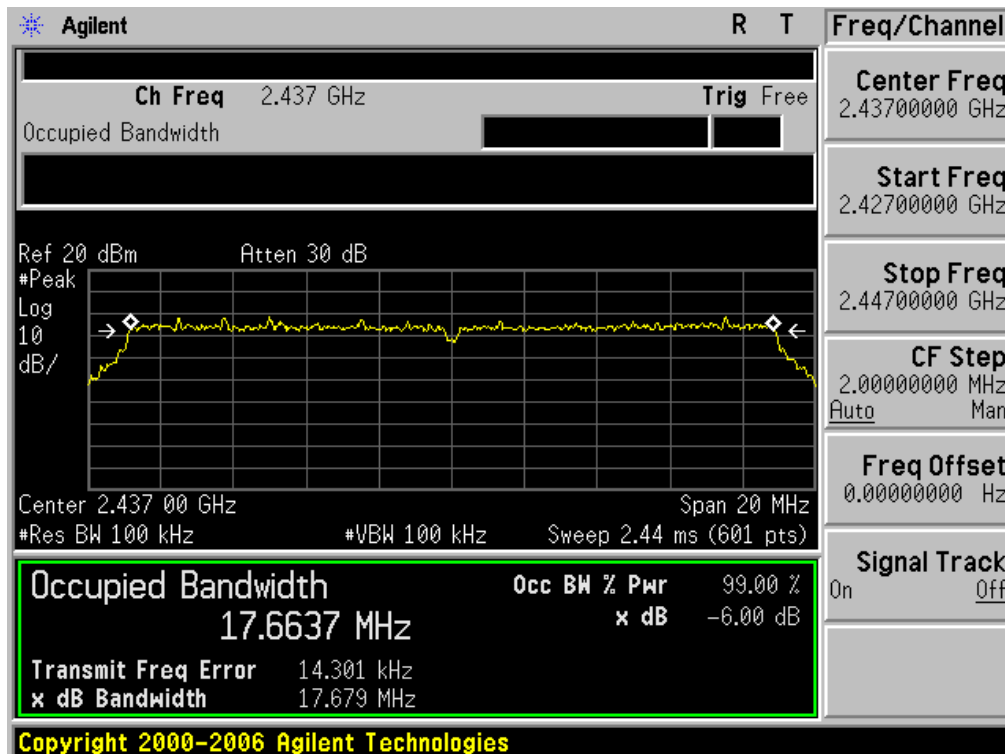

TEST PLOT OF BANDWIDTH FOR HIGH CHANNEL

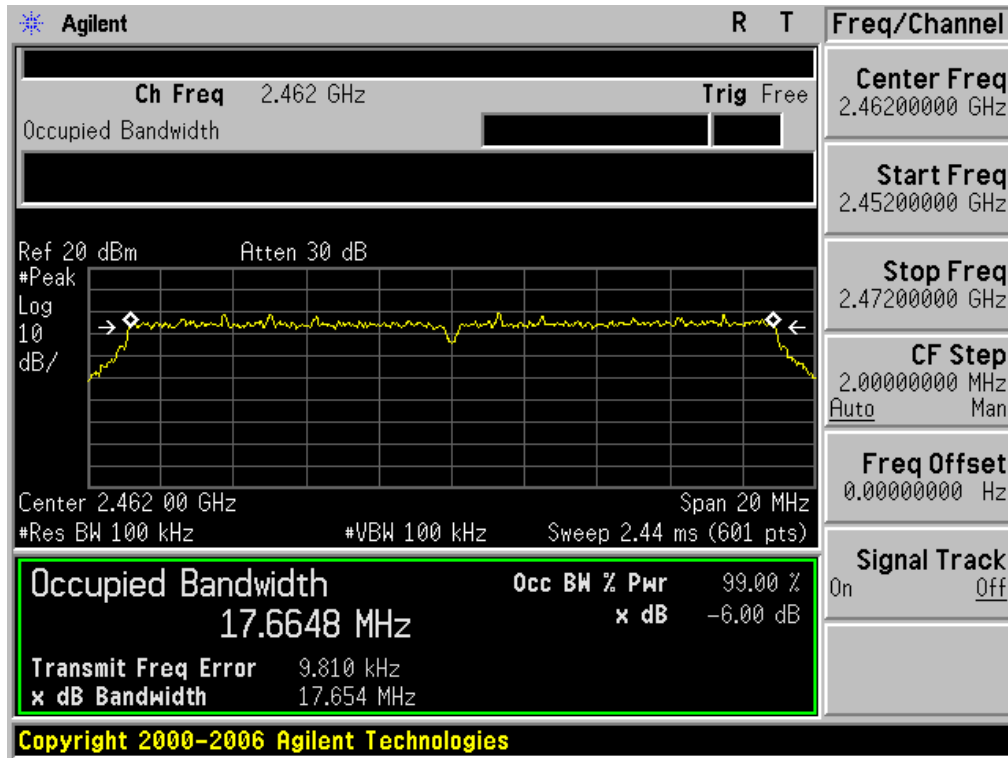

9. CONDUCTED SPURIOUS EMISSION

9.1. MEASUREMENT PROCEDURE

1. The EUT was placed on a turn table which is 0.8m above ground plane.
2. Connect EUT RF output port to the Spectrum Analyzer through an RF attenuator
- 3, Set the EUT Work on the top, the middle and the bottom operation frequency individually.
4. Set SPA Trace 1 Max hold, then View.

Note: The EUT was tested according to KDB 558074 for compliance to FCC 47CFR 15.247 requirements.
Set RBW = 100 kHz, Set VBW > RBW, scan up through 10th harmonic.

9.2. TEST SET-UP (BLOCK DIAGRAM OF CONFIGURATION)

The same as described in section 8.2.

9.3. MEASUREMENT EQUIPMENT USED

The same as described in section 6.

9.4. LIMITS AND MEASUREMENT RESULT

LIMITS AND MEASUREMENT RESULT		
Applicable Limits	Measurement Result	
	Test Data	Criteria
In any 100 KHz Bandwidth Outside the frequency band in which the spread spectrum intentional radiator is operating, the radio frequency power that is produce by the intentional radiator shall be at least 20 dB below that in 100KHz bandwidth within the band that contains the highest level of the desired power. In addition, radiation emissions which fall in the restricted bands, as defined in §15.205(a), must also comply with the radiated emission limits specified in§15.209(a))	At least -20dBc than the limit Specified on the BOTTOM Channel	PASS
	At least -20dBc than the limit Specified on the TOP Channel	PASS

TEST PLOT OF OUT OF BAND EMISSIONS WITH THE WORST CASE
 OF 802.11b FOR MODULATION IN LOW CHANNEL

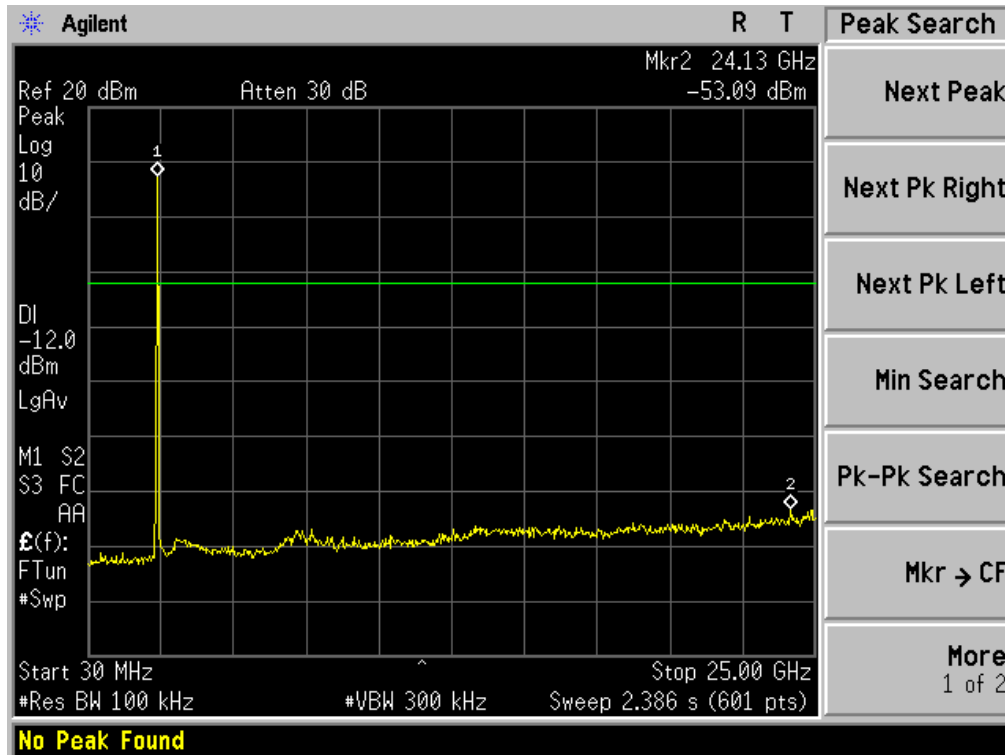

TEST PLOT OF OUT OF BAND EMISSIONS
 OF 802.11b FOR MODULATION IN MIDDLE CHANNEL

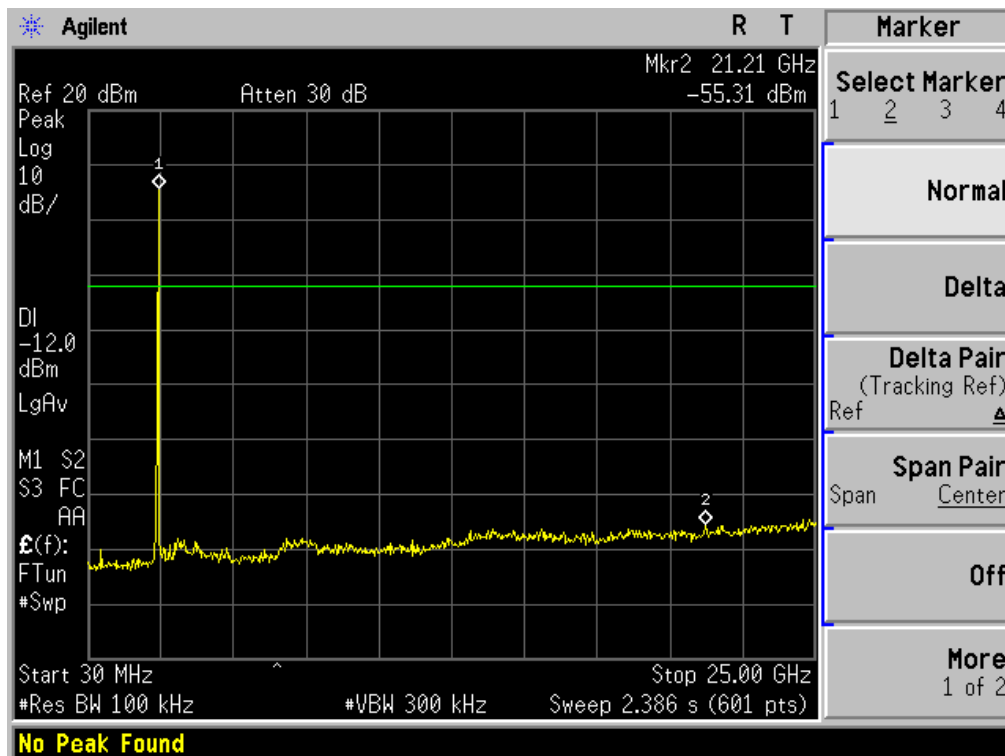

TEST PLOT OF OUT OF BAND EMISSIONS
OF 802.11b FOR MODULATION IN HIGH CHANNEL

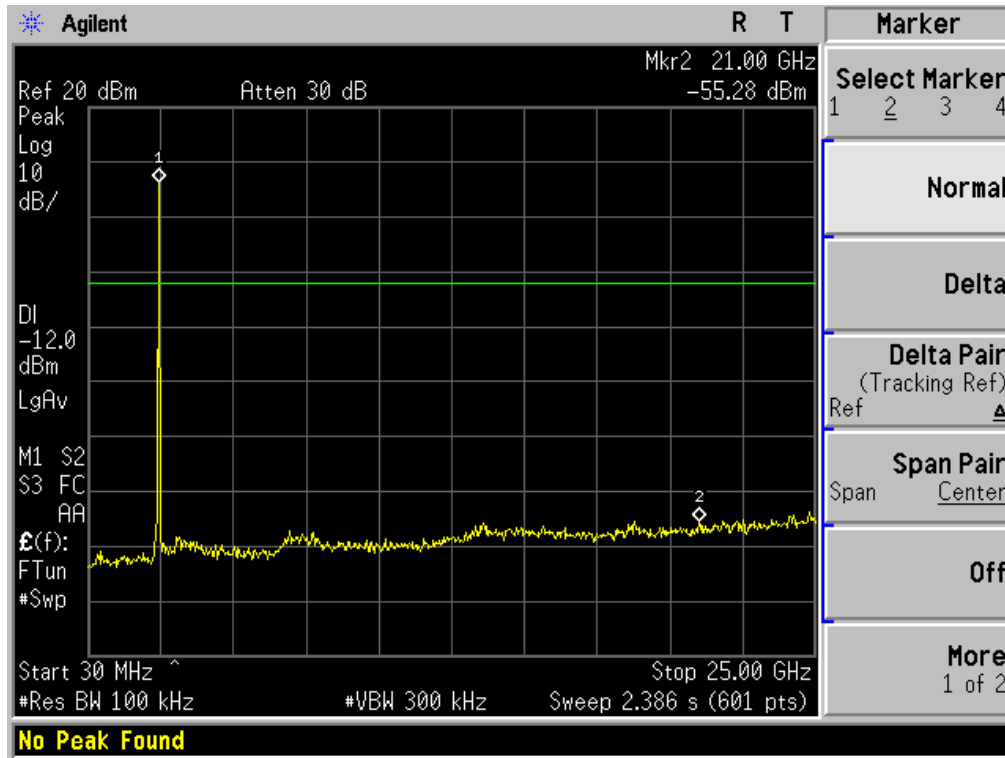

10. MAXIMUM CONDUCTED OUTPUT POWER SPECTRAL DENSITY

10.1 MEASUREMENT PROCEDURE

- (1). The EUT was placed on a turn table which is 0.8m above ground plane.
- (2). Connect EUT RF output port to the Spectrum Analyzer through an RF attenuator
- (3). Set the EUT Work on the top, the middle and the bottom operation frequency individually.
- (4). Set SPA Trace 1 Max hold, then View.

Note: The EUT was tested according to KDB 558074 for compliance to FCC 47CFR 15.247 requirements. Set RBW= 100 kHz, VBW \geq 300KHz, SPAN to 5-30 % greater than the EBW, Scale the observed power level to an equivalent value in 3 kHz by adjusting (reducing) the measured power by a bandwidth correction factor (BWCF) where BWCF = $10\log(3\text{ kHz}/100\text{kHz}) = -15.2\text{ dB}$.

10.2 TEST SET-UP (BLOCK DIAGRAM OF CONFIGURATION)

Refer To Section 8.2.

10.3 MEASUREMENT EQUIPMENT USED

Refer To Section 6.

10.4 LIMITS AND MEASUREMENT RESULT

TEST ITEM	POWER PECTRAL DENSITY
TEST MODE	802.11b with data rate 1

Channel No.	PSD (dBm)	Limit (dBm)	Result
Low Channel	-10.06	8	Pass
Middle Channel	-9.64	8	Pass
High Channel	-8.57	8	Pass

TEST ITEM	POWER PECTRAL DENSITY
TEST MODE	802.11g with data rate 6

Channel No.	PSD (dBm)	Limit (dBm)	Result
Low Channel	-15.58	8	Pass
Middle Channel	-15.22	8	Pass
High Channel	-14.66	8	Pass

TEST ITEM	POWER PECTRAL DENSITY
TEST MODE	802.11n 20 with data rate 6.5

Channel No.	PSD (dBm)	Limit (dBm)	Result
Low Channel	-14.95	8	Pass
Middle Channel	-15.62	8	Pass
High Channel	-14.36	8	Pass

802.11b TEST RESULT
 TEST PLOT OF SPECTRAL DENSITY FOR LOW CHANNEL

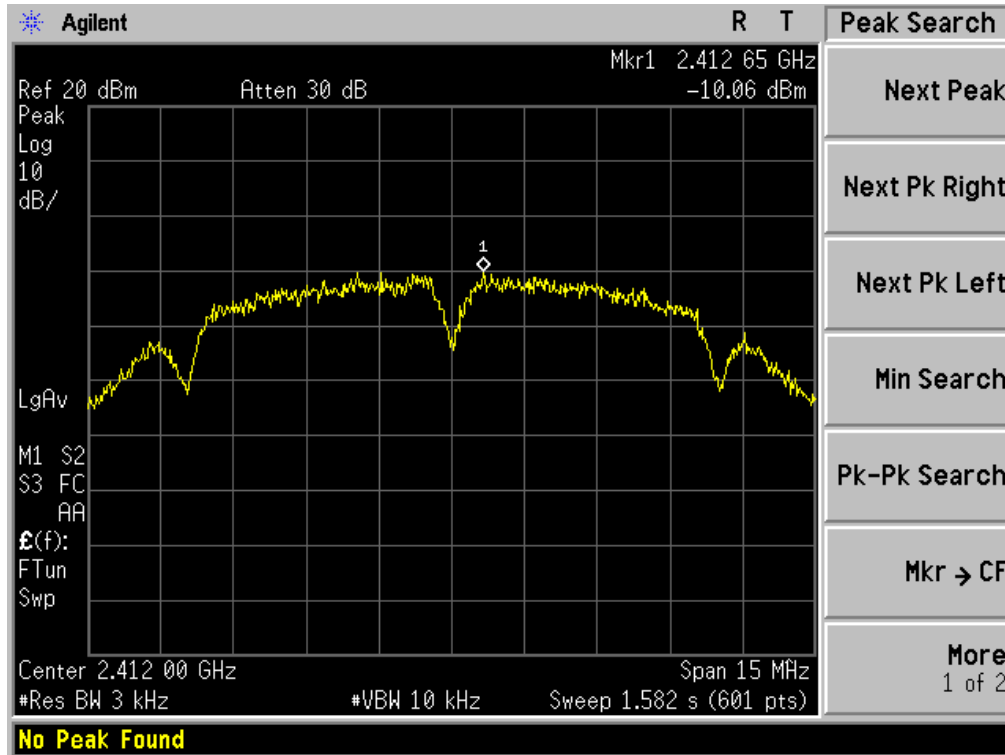

TEST PLOT OF SPECTRAL DENSITY FOR MIDDLE CHANNEL

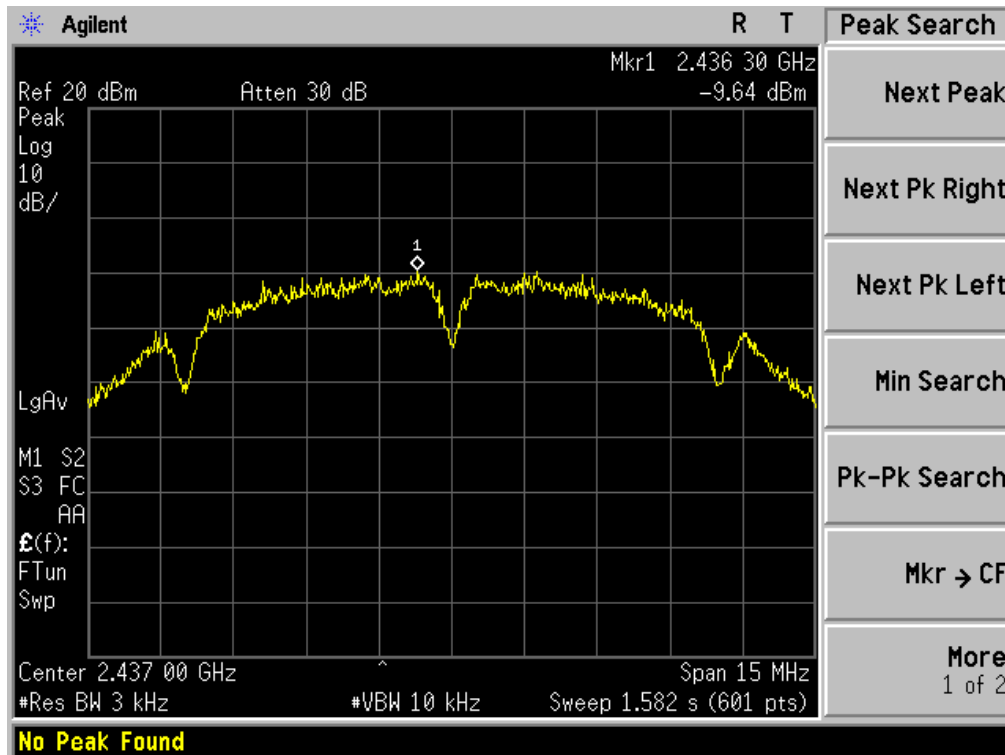

TEST PLOT OF SPECTRAL DENSITY FOR HIGH CHANNEL

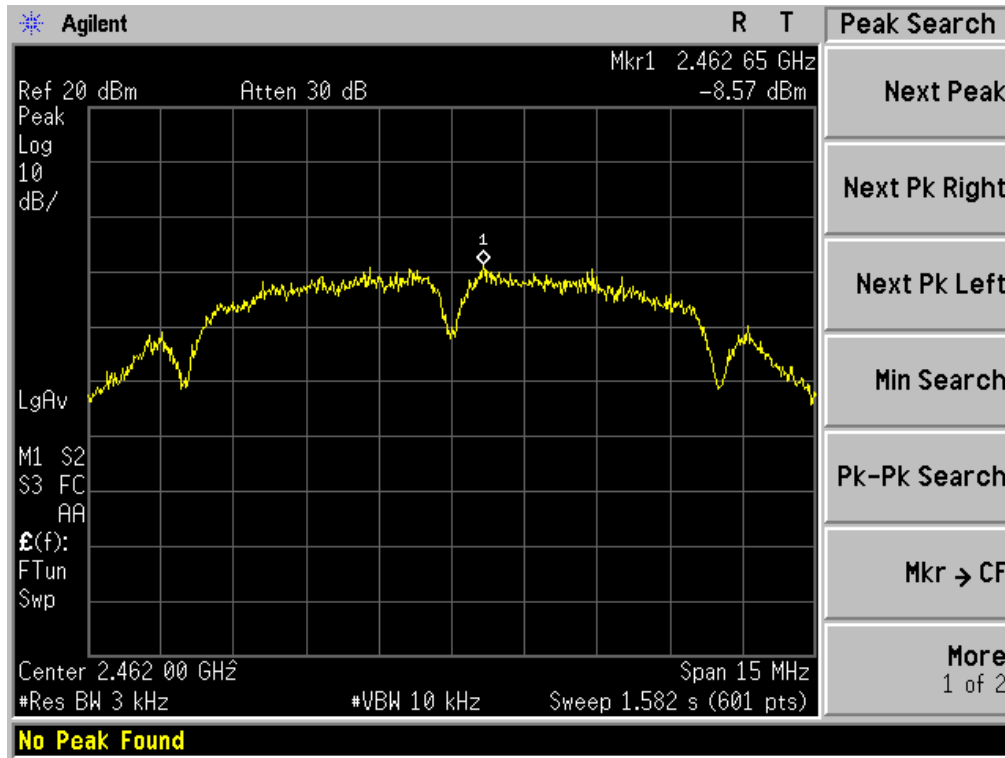

802.11g TEST RESULT

TEST PLOT OF SPECTRAL DENSITY FOR LOW CHANNEL

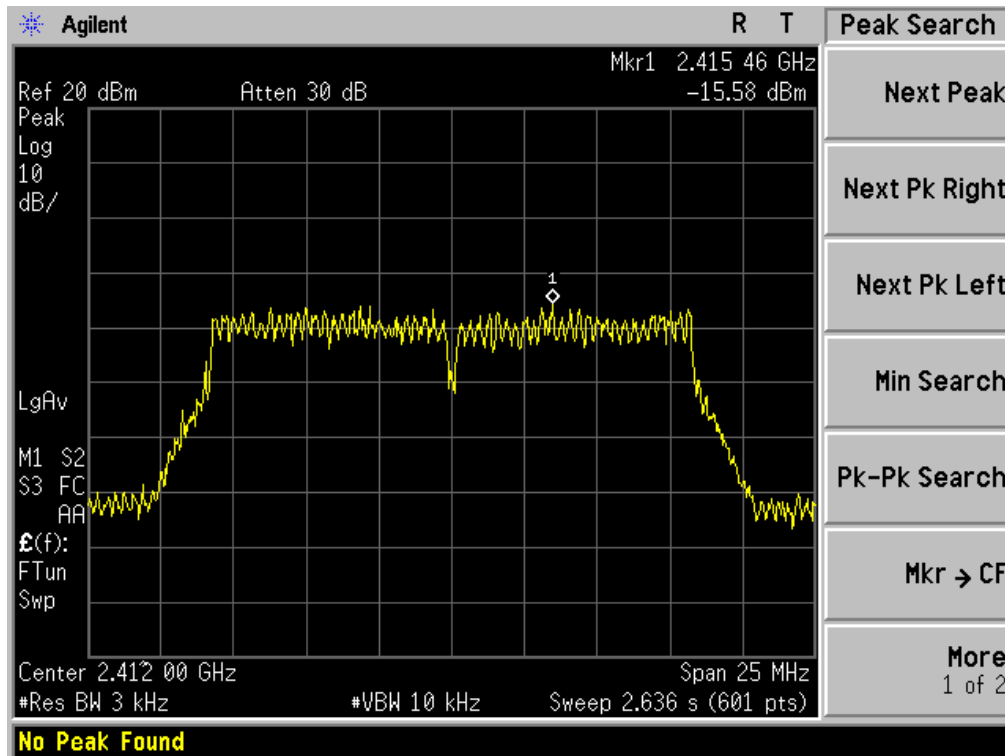

TEST PLOT OF SPECTRAL DENSITY FOR MIDDLE CHANNEL

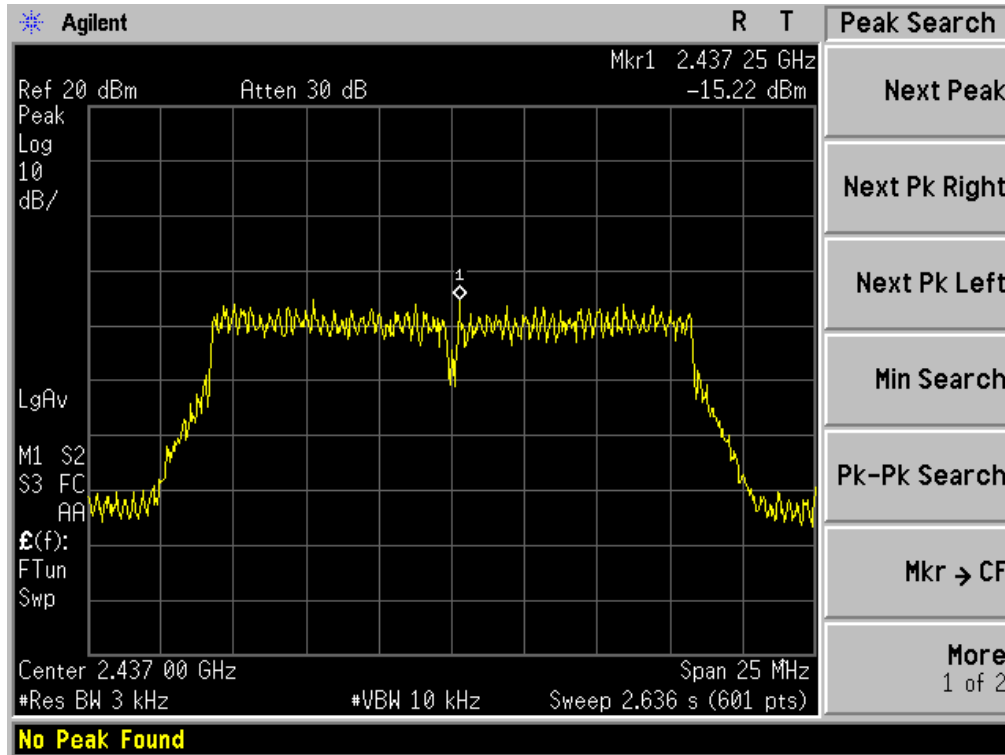

TEST PLOT OF SPECTRAL DENSITY FOR HIGH CHANNEL

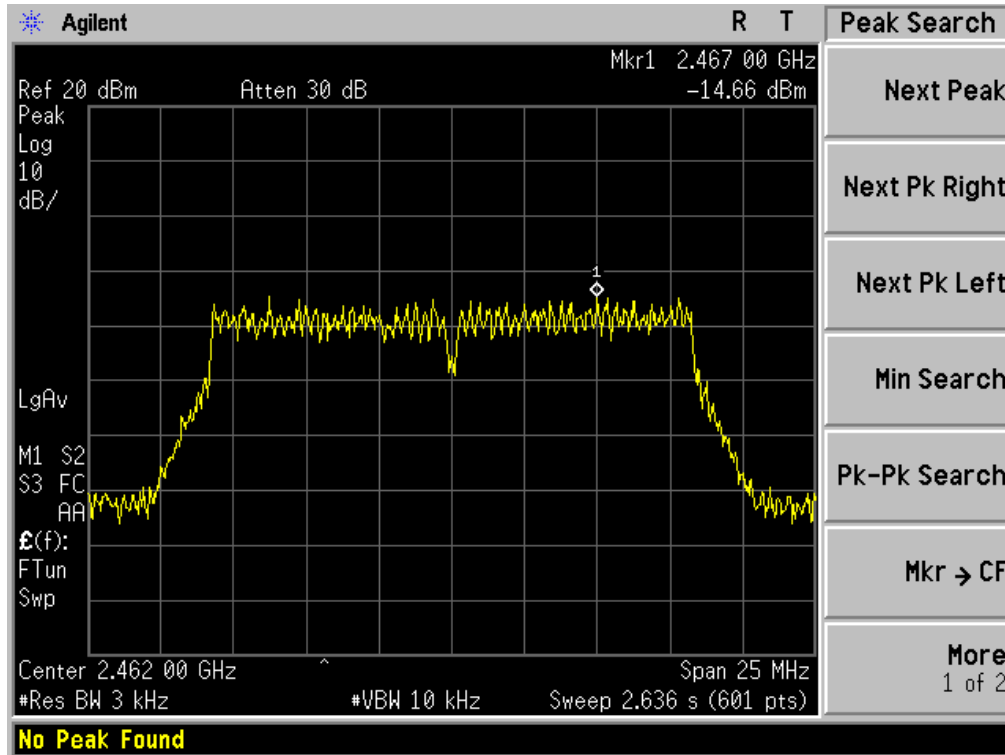

802.11n 20 TEST RESULT
TEST PLOT OF SPECTRAL DENSITY FOR LOW CHANNEL

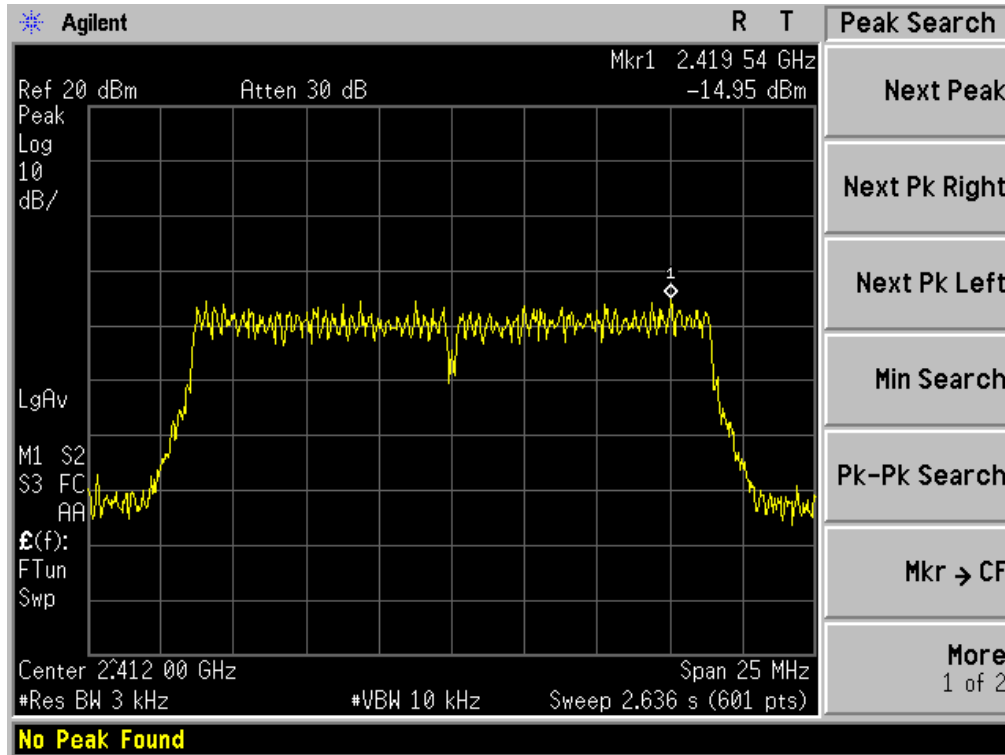

TEST PLOT OF SPECTRAL DENSITY FOR MIDDLE CHANNEL

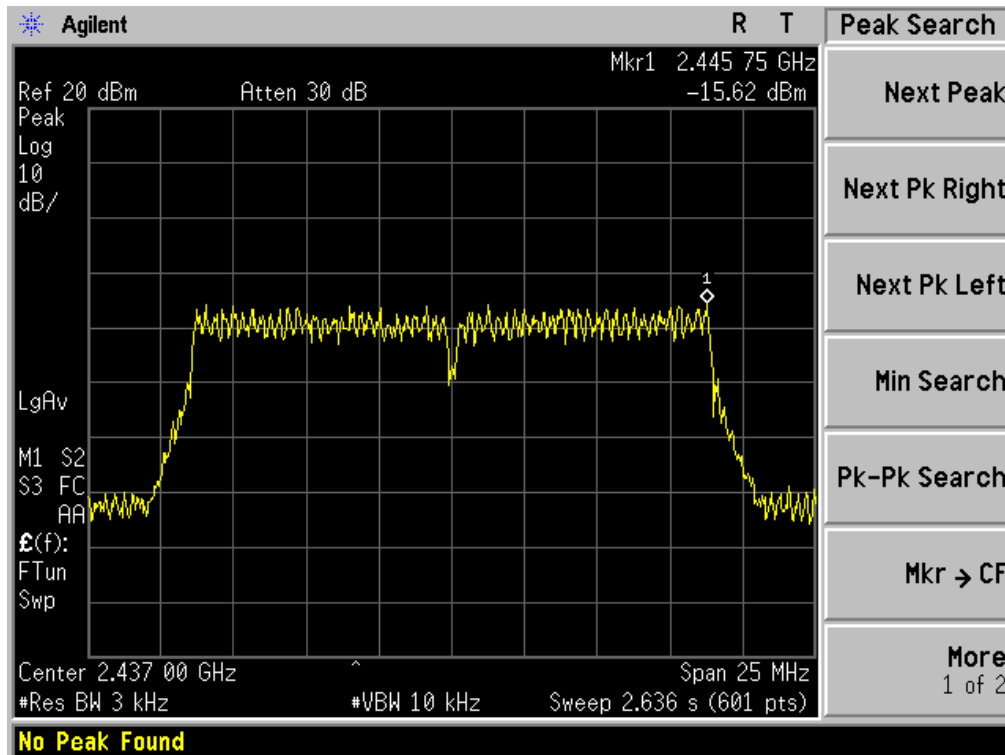

TEST PLOT OF SPECTRAL DENSITY FOR HIGH CHANNEL

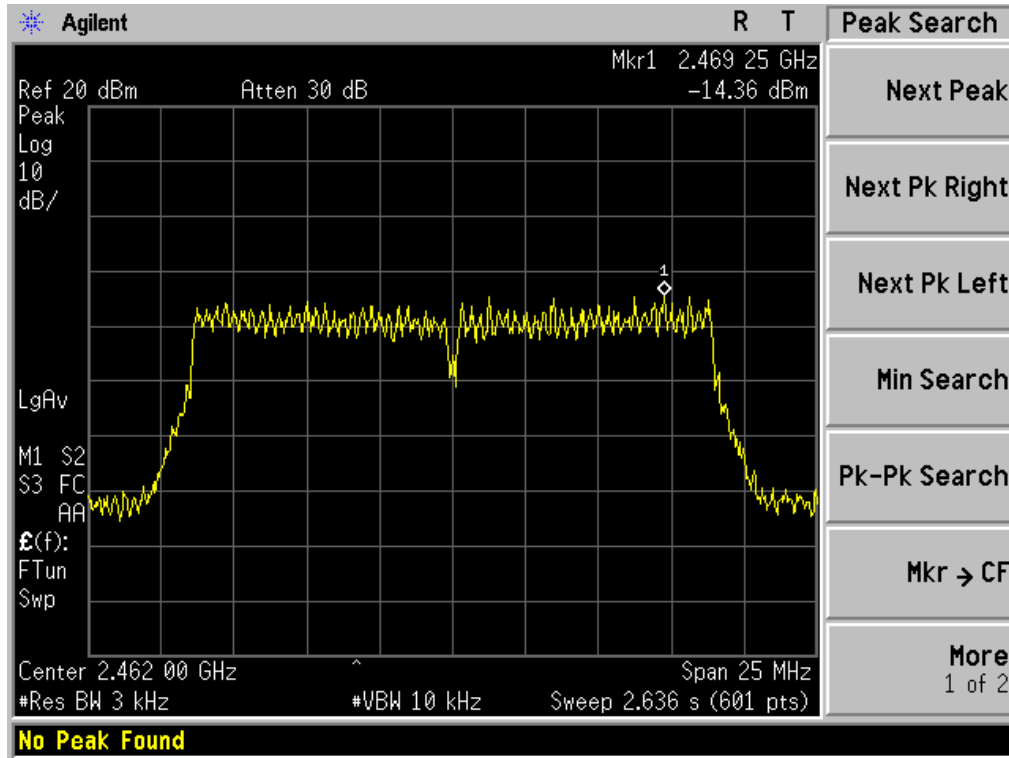

11. RADIATED EMISSION

11.1. MEASUREMENT PROCEDURE

1. Configure the EUT according to ANSI C63.4. The EUT was placed on the top of the turntable 0.8 meter above ground. The phase center of the receiving antenna mounted on the top of a height-variable antenna tower was placed 3 meters far away from the turntable.
2. Power on the EUT and all the supporting units. The turntable was rotated by 360 degrees to determine the position of the highest radiation.
3. The height of the broadband receiving antenna was varied between one meter and four meters above ground to find the maximum emissions field strength of both horizontal and vertical polarization.
4. For each suspected emissions, the antenna tower was scan (from 1 M to 4 M) and then the turntable was rotated (from 0 degree to 360 degrees) to find the maximum reading.
5. Set the test-receiver system to Peak or CISPR quasi-peak Detect Function with specified bandwidth under Maximum Hold Mode.
6. For emissions above 1GHz, use 1MHz VBW and RBW for peak reading. Then 1MHz RBW and 10Hz VBW for average reading in spectrum analyzer.
7. When the radiated emissions limits are expressed in terms of the average value of the emissions, and pulsed operation is employed, the measurement field strength shall be determined by averaging over one complete pulse train, including blanking intervals, as long as the pulse train does not exceed 0.1 seconds. As an alternative (provided the transmitter operates for longer than 0.1 seconds) or in cases where the pulse train exceeds 0.1 seconds, the measured field strength shall be determined from the average absolute voltage during a 0.1 second interval during which the field strength is at its maximum values.
8. If the emissions level of the EUT in peak mode was 3 dB lower than the average limit specified, then testing will be stopped and peak values of EUT will be reported, otherwise, the emissions which do not have 3 dB margin will be repeated one by one using the quasi-peak method for below 1GHz.
9. For testing above 1GHz, the emissions level of the EUT in peak mode was lower than average limit (that means the emissions level in peak mode also complies with the limit in average mode), then testing will be stopped and peak values of EUT will be reported, otherwise, the emissions will be measured in average mode again and reported.
10. In case the emission is lower than 30MHz, loop antenna has to be used for measurement and the recorded data should be QP measured by receiver. High - Low scan is not required in this case.

11.2. TEST SETUP

RADIATED EMISSION TEST SETUP BELOW 30MHz

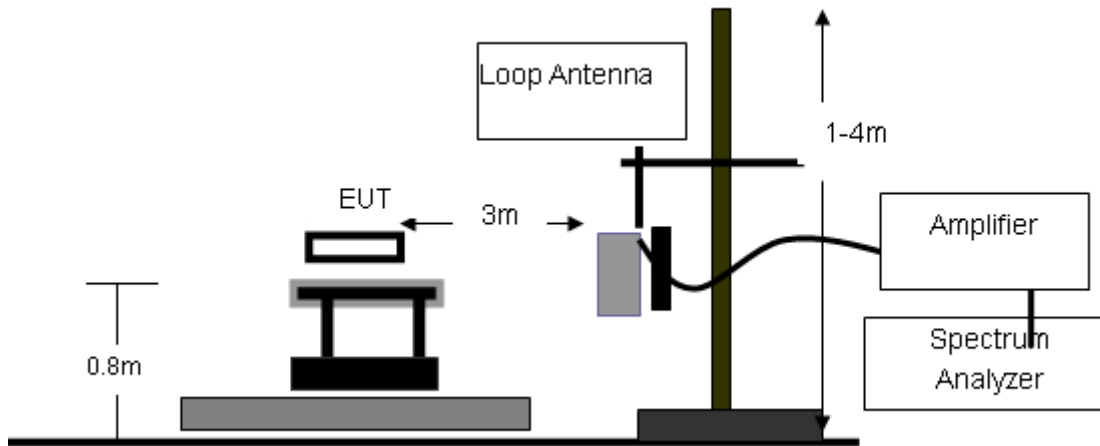

RADIATED EMISSION TEST SETUP 30MHz-1000MHz

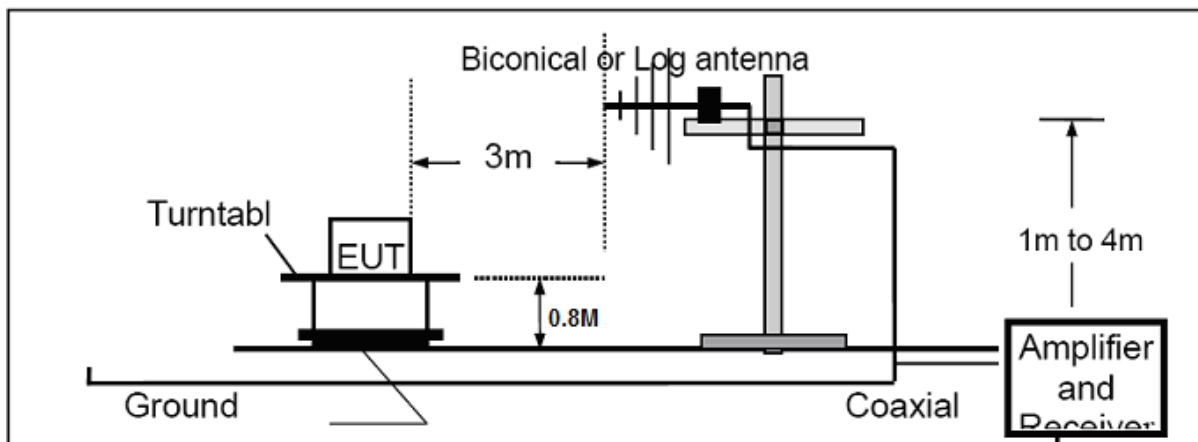

RADIATED EMISSION TEST SETUP ABOVE 1000MHz

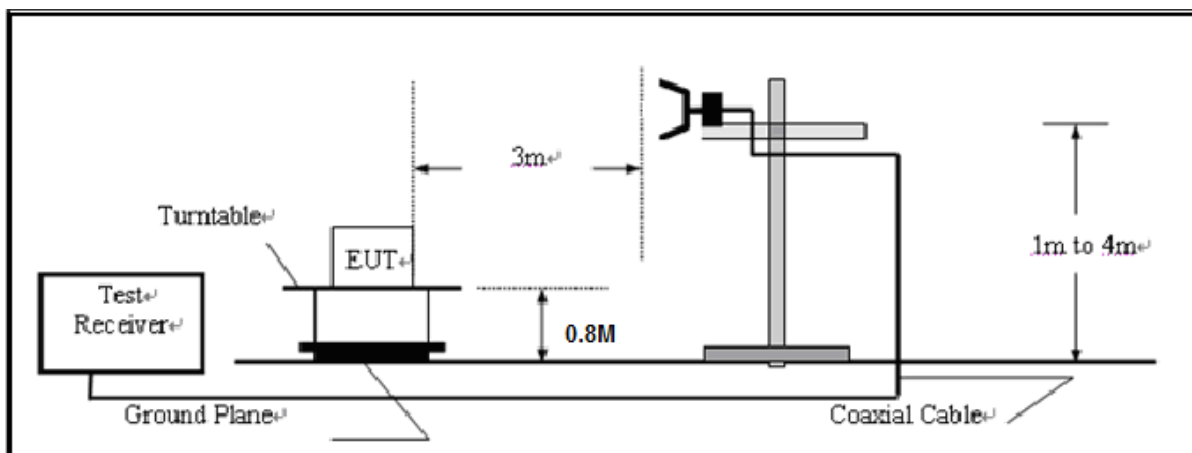

11.3. LIMITS AND MEASUREMENT RESULT

15.209(a) Limit in the below table has to be followed

Frequencies (MHz)	Field Strength (micorvolts/meter)	Measurement Distance (meters)
0.009~0.490	2400/F(KHz)	300
0.490~1.705	24000/F(KHz)	30
1.705~30.0	30	30
30~88	100	3
88~216	150	3
216~960	200	3
Above 960	500	3

Note: All modes were tested For restricted band radiated emission,
the test records reported below are the worst result compared to other modes.

11.4. TEST RESULT

RADIATED EMISSION BELOW 30MHZ

No emission found between lowest internal used/generated frequencies to 30MHz.

RADIATED EMISSION BELOW 1GHZ

EUT	7 Inch Tablet PC	Model Name	TPC7026C
Temperature	25°C	Relative Humidity	55.4%
Pressure	960hPa	Test Voltage	Normal Voltage
Test Mode	802.11b with data rate 1 2412MHZ	Antenna	Horizontal

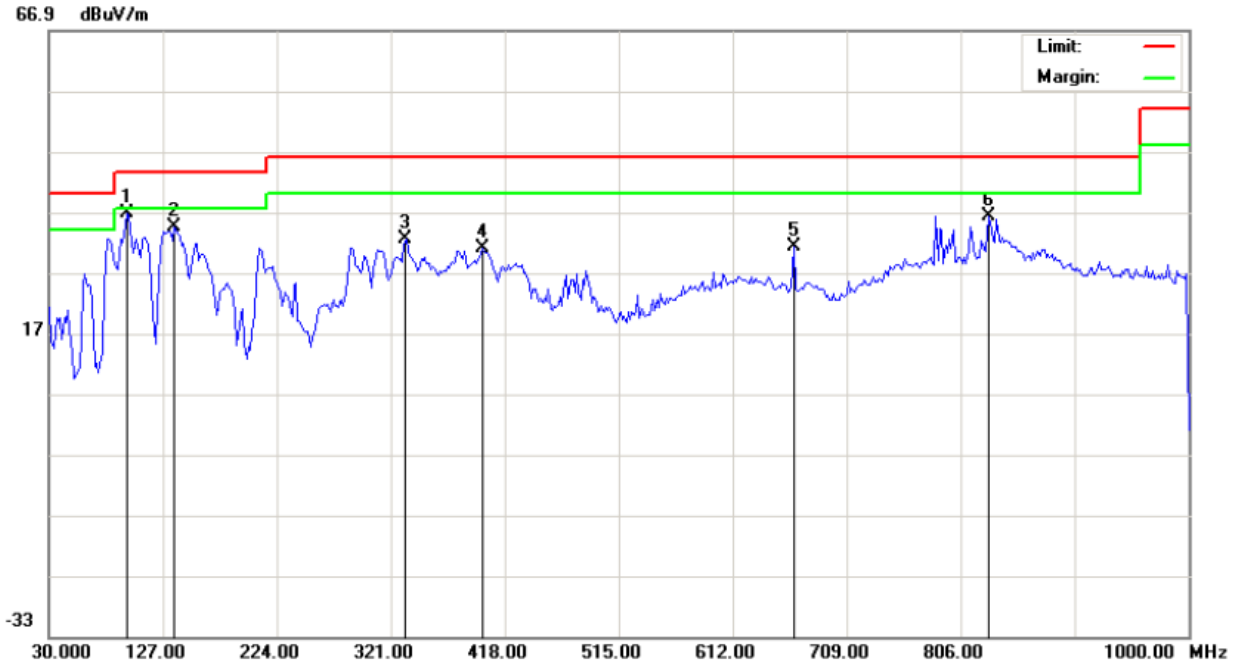

Site: site #1
 Limit: FCC Class B 3M Radiation
 EUT: 7 Inch Tablet PC
 M/N: TPC7026C
 Mode: Low Channel TX
 Note:

Polarization: *Horizontal*
 Power:
 Distance: 3m

Temperature: 26
 Humidity: 60 %

No.	Mk	Freq.	Reading	Factor	Measurement	Limit	Over	Detector	Antenna Height	Table Degree	Comment
		MHz	dBuV	dB/m	dBuV/m	dBuV/m	dB		cm	degree	
1	*	96.2833	26.21	10.51	36.72	43.50	-6.78	peak			
2		136.7000	29.62	4.99	34.61	43.50	-8.89	peak			
3		333.9332	12.64	19.96	32.60	46.00	-13.40	peak			
4		398.6000	14.65	16.28	30.93	46.00	-15.07	peak			
5		663.7333	7.19	24.11	31.30	46.00	-14.70	peak			
6		830.2500	5.03	31.25	36.28	46.00	-9.72	peak			

RESULT: PASS

EUT	7 Inch Tablet PC	Model Name	TPC7026C
Temperature	25°C	Relative Humidity	55.4%
Pressure	960hPa	Test Voltage	Normal Voltage
Test Mode	802.11b with date rate 1 2412MHZ	Antenna	Vertical

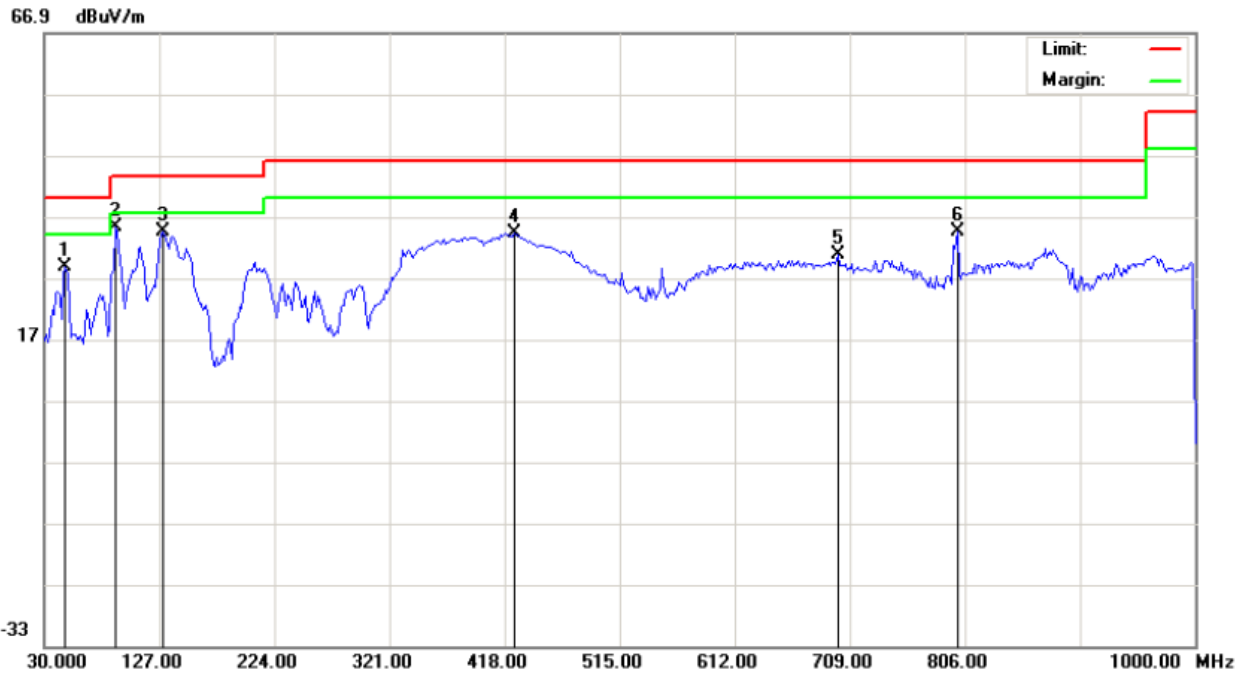

Site: site #1
Limit: FCC Class B 3M Radiation
EUT: 7 Inch Tablet PC
M/N: TPC7026C
Mode: Low Channel TX
Note:

Polarization: *Vertical*
Power:
Distance: 3m

Temperature: 26
Humidity: 60 %

No.	Mk	Freq.	Reading	Factor	Measurement	Limit	Over	Detector	Antenna Height	Table Degree	Comment
		MHz	dBuV	dB/m	dBuV/m	dBuV/m	dB		cm	degree	
1		47.7832	24.71	4.04	28.75	40.00	-11.25	peak			
2	*	89.8167	30.25	5.02	35.27	43.50	-8.23	peak			
3		130.2333	33.21	1.22	34.43	43.50	-9.07	peak			
4		426.0833	13.00	21.27	34.27	46.00	-11.73	peak			
5		699.3000	3.23	27.59	30.82	46.00	-15.18	peak			
6		799.5333	5.28	29.32	34.60	46.00	-11.40	peak			

RESULT: PASS

EUT	7 Inch Tablet PC	Model Name	TPC7026C
Temperature	25°C	Relative Humidity	55.4%
Pressure	960hPa	Test Voltage	Normal Voltage
Test Mode	802.11b with data rate 1 2437MHZ	Antenna	Horizontal

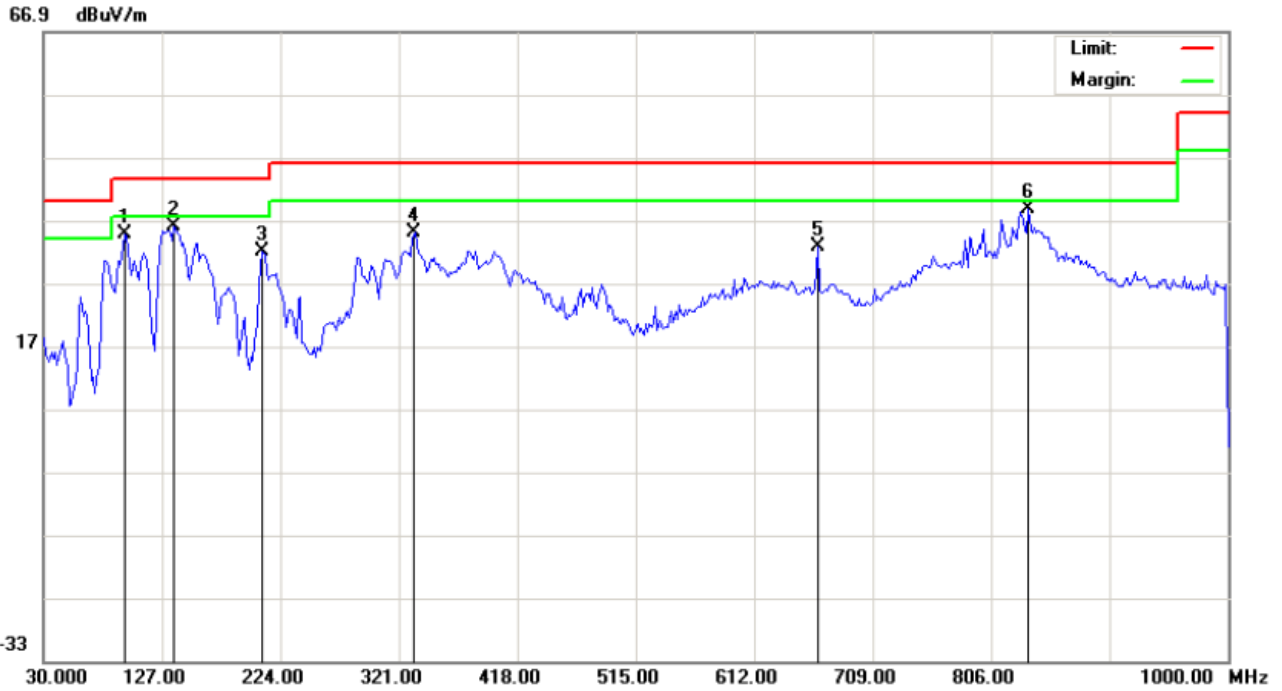

Site: site #1 Polarization: **Horizontal** Temperature: 26
 Limit: FCC Class B 3M Radiation Power: Humidity: 60 %
 EUT: 7 Inch Tablet PC Distance: 3m
 M/N: TPC7026C
 Mode: Middle Channel TX
 Note:

No.	Mk	Freq.	Reading	Factor	Measurement	Limit	Over	Detector	Antenna Height	Table Degree	Comment
		MHz	dBuV	dB/m	dBuV/m	dBuV/m	dB		cm	degree	
1		96.2833	24.21	10.51	34.72	43.50	-8.78	peak			
2		136.7000	31.12	4.99	36.11	43.50	-7.39	peak			
3		209.4500	23.95	8.19	32.14	43.50	-11.36	peak			
4		333.9332	15.14	19.96	35.10	46.00	-10.90	peak			
5		663.7333	8.69	24.11	32.80	46.00	-13.20	peak			
6	*	836.7166	6.49	32.24	38.73	46.00	-7.27	peak			

RESULT: PASS

EUT	7 Inch Tablet PC	Model Name	TPC7026C
Temperature	25°C	Relative Humidity	55.4%
Pressure	960hPa	Test Voltage	Normal Voltage
Test Mode	802.11b with data rate 1 2437MHZ	Antenna	Vertical

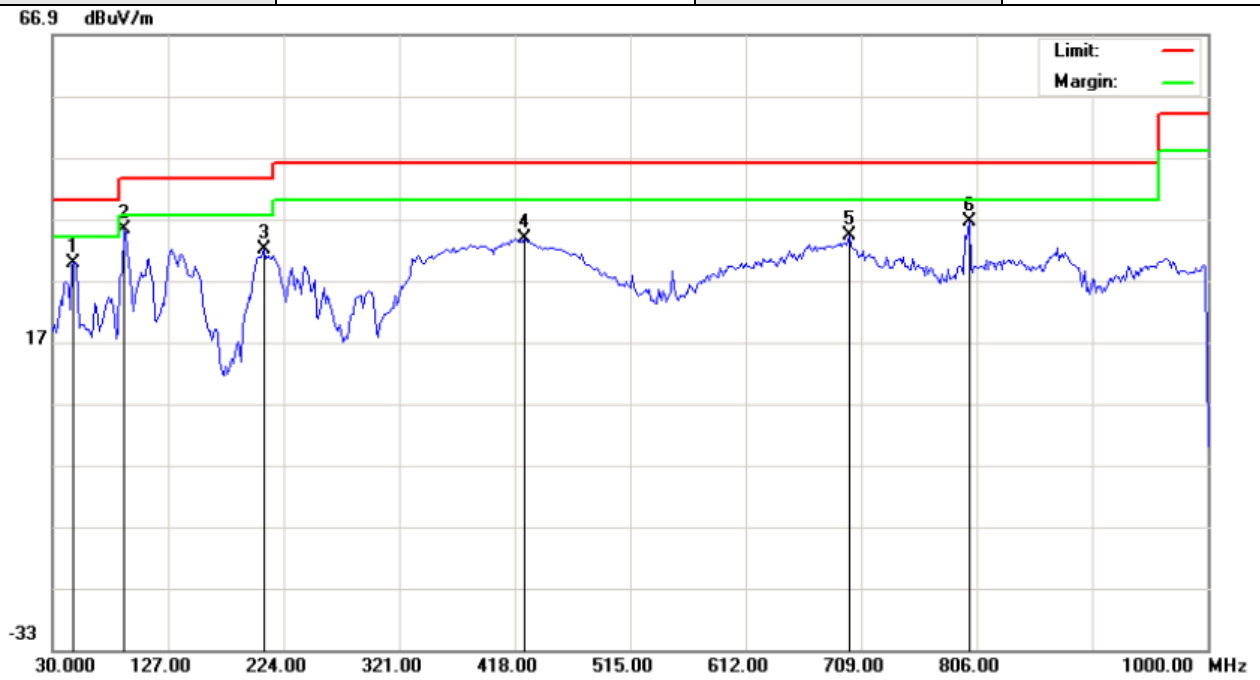

Site: site #1
 Limit: FCC Class B 3M Radiation
 EUT: 7 Inch Tablet PC
 M/N: TPC7026C
 Mode: Middle Channel TX
 Note:

Polarization: *Vertical*
 Power:
 Distance: 3m

Temperature: 26
 Humidity: 60 %

No.	Mk	Freq.	Reading	Factor	Measurement	Limit	Over	Detector	Antenna Height	Table Degree	Comment
		MHz	dBuV	dB/m	dBuV/m	dBuV/m	dB		cm	degree	
1		47.7832	25.71	4.04	29.75	40.00	-10.25	peak			
2	*	89.8167	30.25	5.02	35.27	43.50	-8.23	peak			
3		207.8333	24.68	7.32	32.00	43.50	-11.50	peak			
4		426.0833	12.50	21.27	33.77	46.00	-12.23	peak			
5		699.3000	6.73	27.59	34.32	46.00	-11.68	peak			
6		799.5333	7.28	29.32	36.60	46.00	-9.40	peak			

RESULT: PASS

EUT	7 Inch Tablet PC	Model Name	TPC7026C
Temperature	25°C	Relative Humidity	55.4%
Pressure	960hPa	Test Voltage	Normal Voltage
Test Mode	802.11b with data rate 1 2462MHZ	Antenna	Horizontal

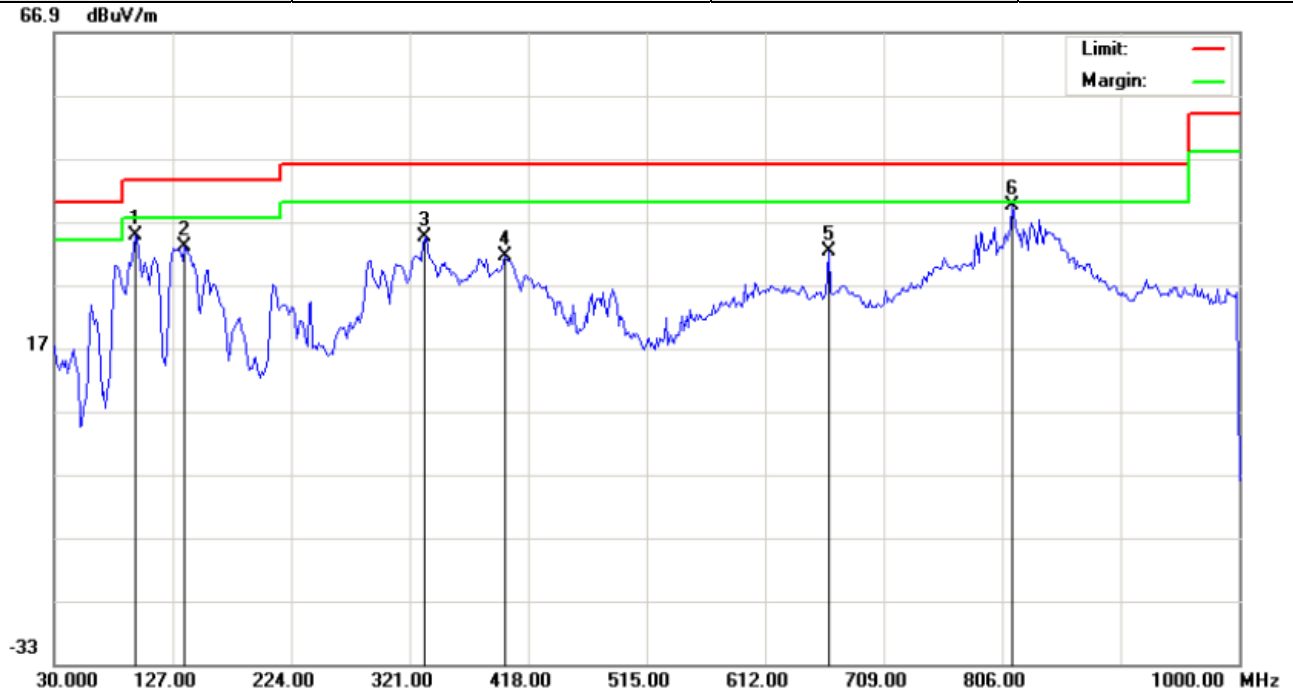

Site: site #1
Limit: FCC Class B 3M Radiation
EUT: 7 Inch Tablet PC
M/N: TPC7026C
Mode: High Channel TX
Note:

Polarization: **Horizontal**
Power:
Distance: 3m

Temperature: 26
Humidity: 60 %

No.	Mk	Freq.	Reading	Factor	Measurement	Limit	Over	Detector	Antenna Height	Table Degree	Comment
		MHz	dBuV	dB/m	dBuV/m	dBuV/m	dB		cm	degree	
1		96.2833	24.21	10.51	34.72	43.50	-8.78	peak			
2		136.7000	28.12	4.99	33.11	43.50	-10.39	peak			
3		333.9332	14.64	19.96	34.60	46.00	-11.40	peak			
4		398.6000	15.15	16.28	31.43	46.00	-14.57	peak			
5		663.7333	8.19	24.11	32.30	46.00	-13.70	peak			
6	*	814.0833	9.98	29.54	39.52	46.00	-6.48	peak			

RESULT: PASS

EUT	7 Inch Tablet PC	Model Name	TPC7026C
Temperature	25°C	Relative Humidity	55.4%
Pressure	960hPa	Test Voltage	Normal Voltage
Test Mode	802.11b with date rate 1 2462MHZ	Antenna	Vertical

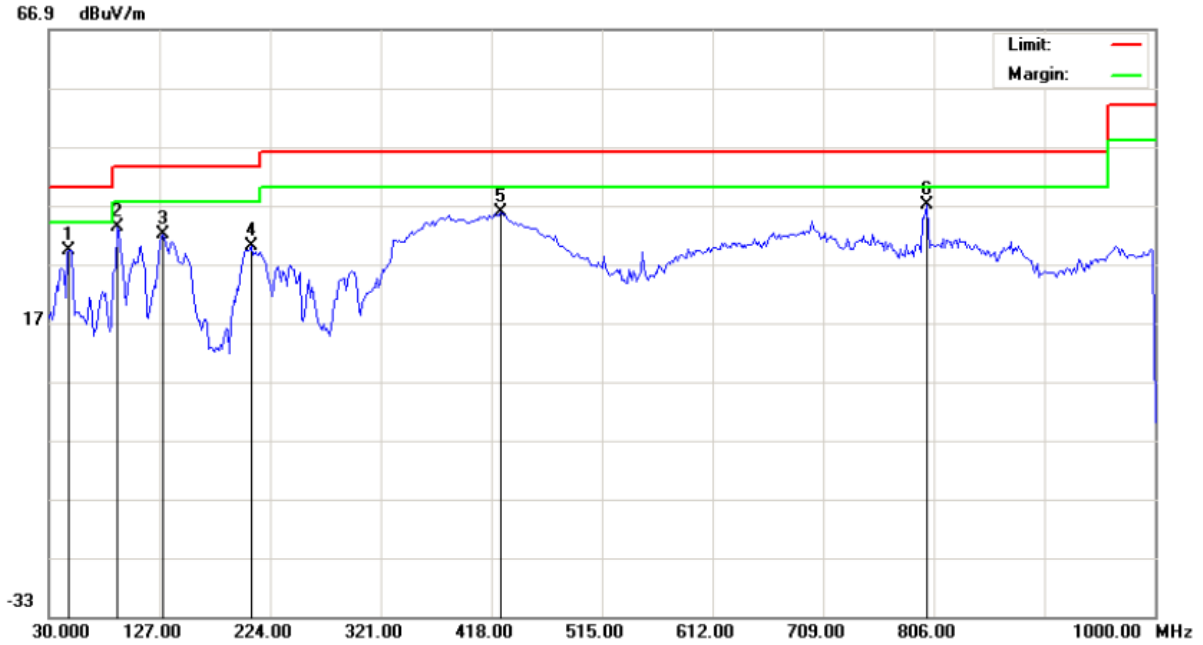

Site: site #1
Limit: FCC Class B 3M Radiation
EUT: 7 Inch Tablet PC
M/N: TPC7026C
Mode: High Channel TX
Note:

Polarization: *Vertical*
Power:
Distance: 3m

Temperature: 26
Humidity: 60 %

No.	Mk	Freq.	Reading	Factor	Measurement	Limit	Over	Detector	Antenna Height	Table Degree	Comment
		MHz	dBuV	dB/m	dBuV/m	dBuV/m	dB		cm	degree	
1		47.7832	25.21	4.04	29.25	40.00	-10.75	peak			
2		89.8167	28.25	5.02	33.27	43.50	-10.23	peak			
3		130.2333	30.71	1.22	31.93	43.50	-11.57	peak			
4		207.8333	22.68	7.32	30.00	43.50	-13.50	peak			
5		426.0833	14.50	21.27	35.77	46.00	-10.23	peak			
6	*	799.5333	7.78	29.32	37.10	46.00	-8.90	peak			

RESULT: PASS

Note: Measurement= Reading + Factor, Over=Measure-Limit.

RADIATED EMISSION ABOVE 1GHZ

EUT	7 Inch Tablet PC	Model Name	TPC7026C
Temperature	25°C	Relative Humidity	55.4%
Pressure	960hPa	Test Voltage	Normal Voltage
Test Mode	802.11b with data rate 1 2412MHZ	Antenna	Horizontal

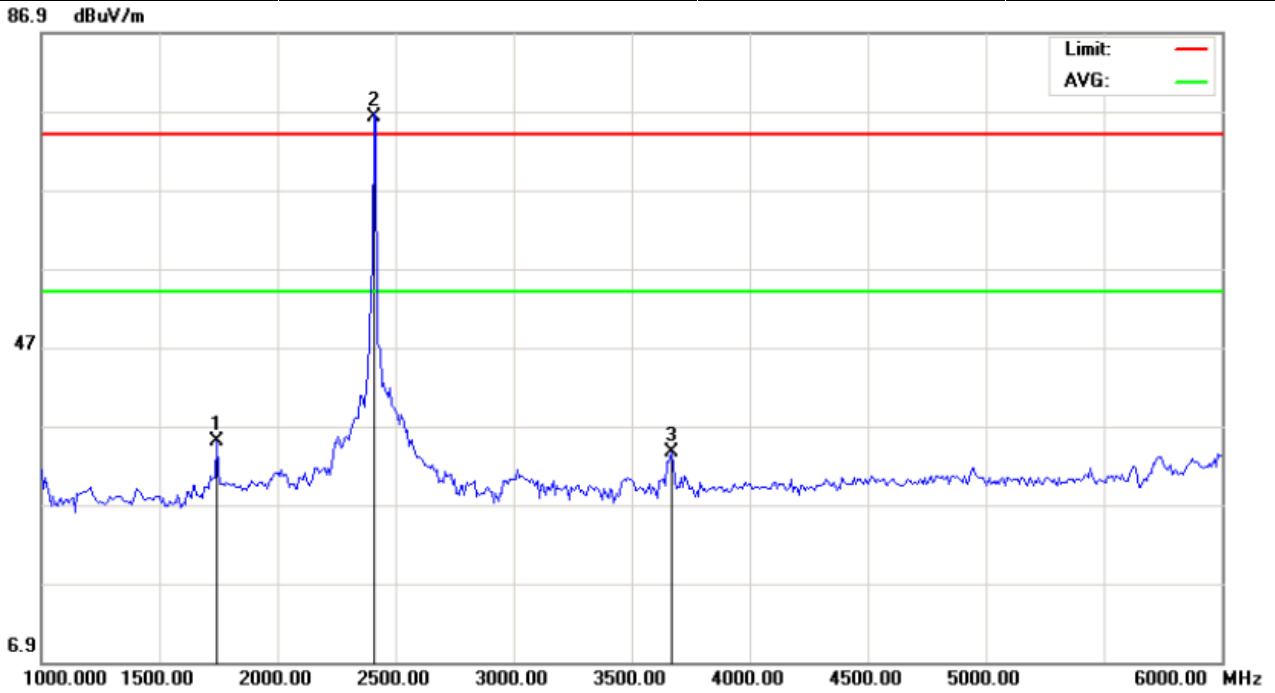

Site: site #1 Polarization: **Horizontal** Temperature: 26
 Limit: FCC Class B 3M Radiation above 1GHZ(PK) Power: Humidity: 60 %
 EUT: 7 Inch Tablet PC Distance: 3m
 M/N: TPC7026C
 Mode: Low channel
 Note:

No.	Mk	Freq.	Reading	Factor	Measurement	Limit	Over	Detector	Antenna	Table	Comment
		MHz	dBuV	dB/m	dBuV/m	dBuV/m	dB		Height	Degree	
									cm	degree	
1		1741.667	34.91	0.00	34.91	74.00	-39.09	peak			
2	*	2412.092	76.16	0.00	76.16	74.00	2.16	peak			
3		3666.667	33.60	0.00	33.60	74.00	-40.40	peak			

RESULT: PASS

EUT	7 Inch Tablet PC	Model Name	TPC7026C
Temperature	25°C	Relative Humidity	55.4%
Pressure	960hPa	Test Voltage	Normal Voltage
Test Mode	802.11b with data rate 1 2412MHZ	Antenna	Vertical

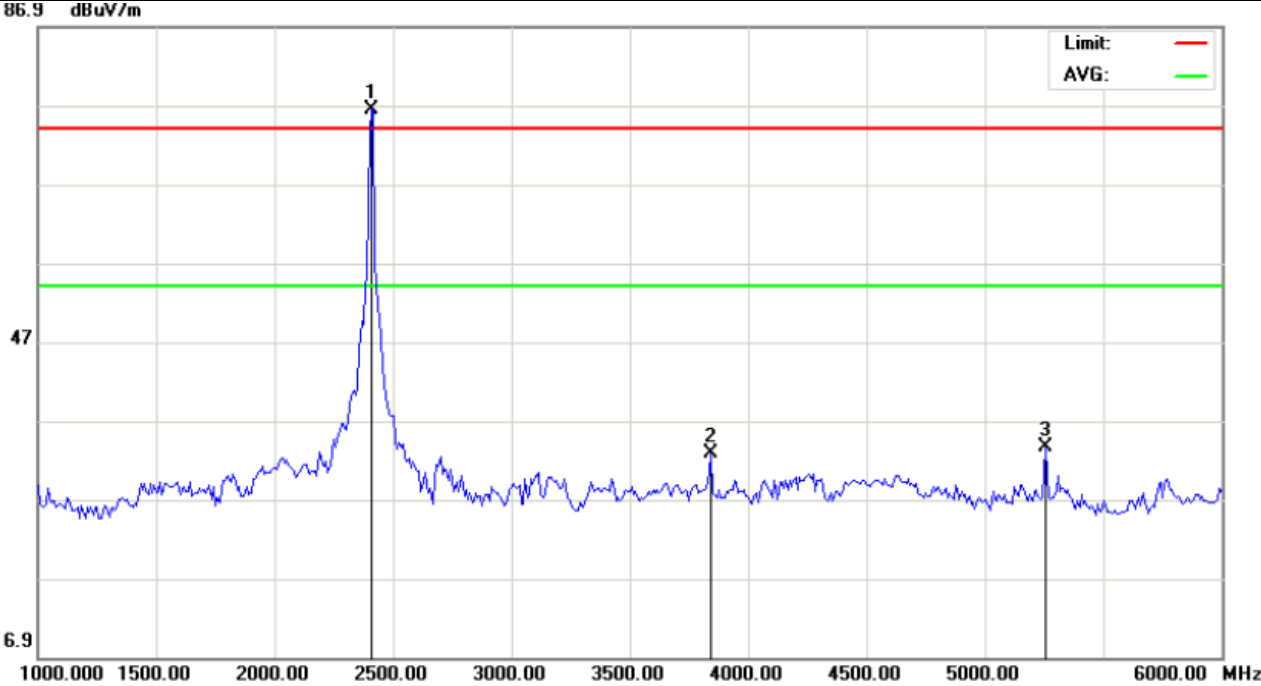

Site: site #1 Polarization: **Vertical** Temperature: 26
 Limit: FCC Class B 3M Radiation above 1GHZ(PK) Power: Humidity: 60 %
 EUT: 7 Inch Tablet PC Distance: 3m
 M/N: TPC7026C
 Mode: Low channel
 Note:

No.	Mk	Freq.	Reading	Factor	Measurement	Limit	Over	Detector	Antenna	Table	Comment
		MHz	dBuV	dB/m	dBuV/m	dBuV/m	dB		Height	Degree	
1	*	2412.088	76.42	0.00	76.42	74.00	2.42	peak	cm	degree	
2		3841.667	32.83	0.00	32.83	74.00	-41.17	peak			
3		5258.333	33.56	0.00	33.56	74.00	-40.44	peak			

RESULT: PASS

Note: The other modes radiation emissions have more than 20dB margin.
 Measurement= Reading + Factor, Over=Measure-Limit.
 All modes radiation emission from 5GHz to 25GHz at least have 20dB margin.

12. BAND EDGE EMISSION

12.1. MEASUREMENT PROCEDURE

1. Set the EUT Work on the top, the bottom operation frequency individually.
2. Set SPA Start or Stop Frequency = Operation Frequency, $RBW \geq 1\% \text{span}$, $VBW \geq RBW$
3. The band edges was measured and recorded.

12.2. TEST SET-UP

Radiated same as 11.2

12.3. TEST RESULT

EUT	7 Inch Tablet PC	Model Name	TPC7026C
Temperature	25°C	Relative Humidity	55.4%
Pressure	960hPa	Test Voltage	Normal Voltage
Test Mode	802.11b with data rate 1 2412MHZ	Antenna	Horizontal

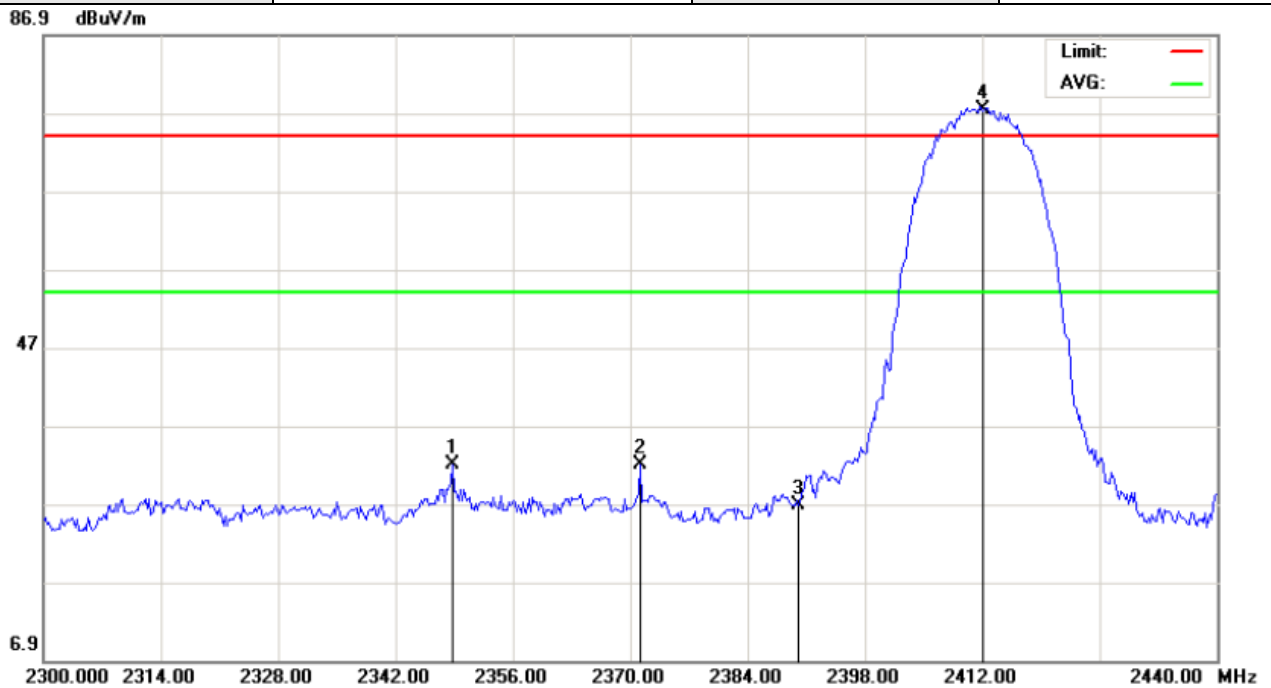

Site: site #1
Limit: FCC Class B 3M Radiation above 1GHZ(PK)
EUT: 7 Inch Tablet PC
M/N: TPC7026C
Mode: 802.11b Low channel TX
Note:

Polarization: **Horizontal**
Power:
Distance: 3m

Temperature: 26
Humidity: 60 %

No.	Mk	Freq.	Reading	Factor	Measurement	Limit	Over	Detector	Antenna Height	Table Degree	Comment
		MHz	dBuV	dB/m	dBuV/m	dBuV/m	dB		cm	degree	
1		2348.767	31.96	0.00	31.96	74.00	-42.04	peak			
2		2371.167	32.03	0.00	32.03	74.00	-41.97	peak			
3		2390.000	26.75	0.00	26.75	74.00	-47.25	peak			
4	*	2412.103	77.36	0.00	77.36	74.00	3.36	peak			

RESULT: PASS

EUT	7 Inch Tablet PC	Model Name	TPC7026C
Temperature	25°C	Relative Humidity	55.4%
Pressure	960hPa	Test Voltage	Normal Voltage
Test Mode	802.11b with data rate 1 2412MHZ	Antenna	Vertical

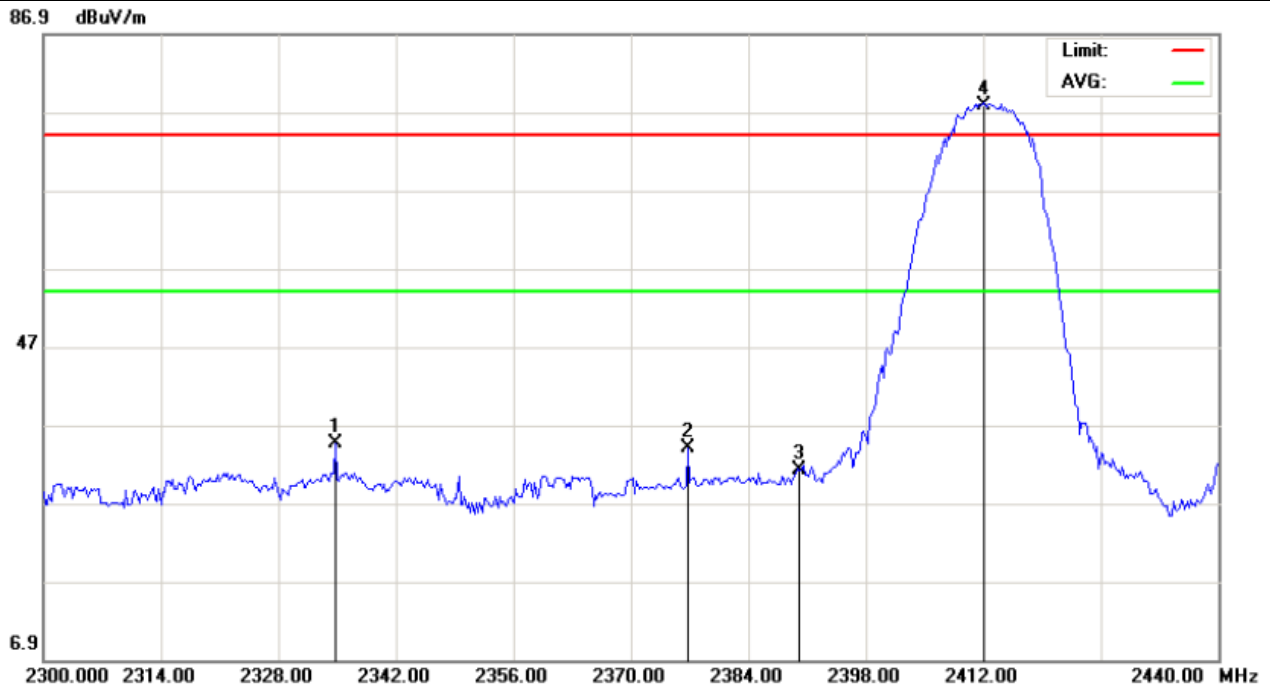

Site: site #1 Polarization: **Vertical** Temperature: 26
 Limit: FCC Class B 3M Radiation above 1GHZ(PK) Power: Humidity: 60 %
 EUT: 7 Inch Tablet PC Distance: 3m
 M/N: TPC7026C
 Mode: 802.11b Low channel TX
 Note:

No.	Mk	Freq.	Reading	Factor	Measurement	Limit	Over	Detector	Antenna	Table	Comment
		MHz	dBuV	dB/m	dBuV/m	dBuV/m	dB		Height	Degree	
									cm	degree	
1		2334.767	34.55	0.00	34.55	74.00	-39.45	peak			
2		2376.767	34.04	0.00	34.04	74.00	-39.96	peak			
3		2390.000	31.25	0.00	31.25	74.00	-42.75	peak			
4	*	2412.094	77.86	0.00	77.86	74.00	3.86	peak			

RESULT: PASS

EUT	7 Inch Tablet PC	Model Name	TPC7026C
Temperature	25°C	Relative Humidity	55.4%
Pressure	960hPa	Test Voltage	Normal Voltage
Test Mode	802.11b with data rate 1 2462MHZ	Antenna	Horizontal

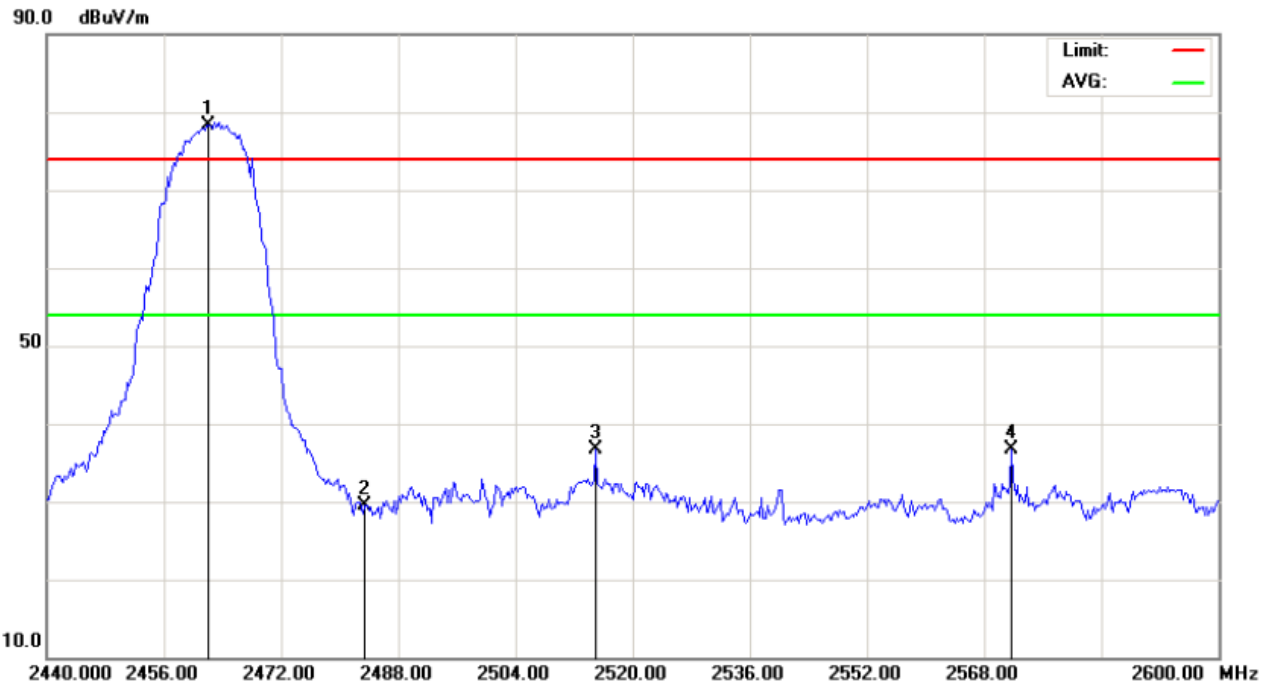

Site: site #1
Limit: FCC Class B 3M Radiation above 1GHZ(PK)
EUT: 7 Inch Tablet PC
M/N: TPC7026C
Mode: 802.11b High channel TX
Note:

Polarization: *Horizontal*
Power:
Distance: 3m

Temperature: 26
Humidity: 60 %

No.	Mk	Freq.	Reading	Factor	Measurement	Limit	Over	Detector	Antenna Height	Table Degree	Comment
		MHz	dBuV	dB/m	dBuV/m	dBuV/m	dB		cm	degree	
1	*	2462.088	78.26	0.00	78.26	74.00	4.26	peak			
2		2483.500	29.58	0.00	29.58	74.00	-44.42	peak			
3		2514.933	36.74	0.00	36.74	74.00	-37.26	peak			
4		2571.733	36.72	0.00	36.72	74.00	-37.28	peak			

RESULT: PASS

EUT	7 Inch Tablet PC	Model Name	TPC7026C
Temperature	25°C	Relative Humidity	55.4%
Pressure	960hPa	Test Voltage	Normal Voltage
Test Mode	802.11b with data rate 1 2462MHZ	Antenna	Vertical

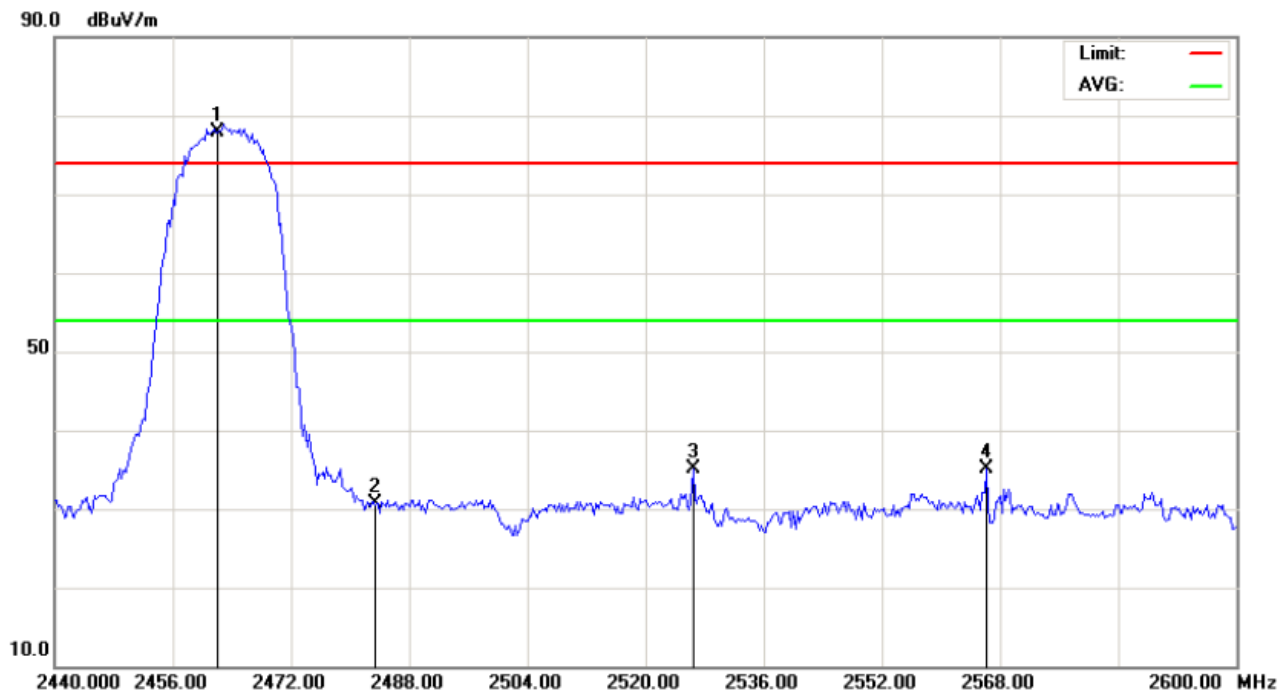

Site: site #1 Polarization: *Vertical* Temperature: 26
Limit: FCC Class B 3M Radiation above 1GHZ(PK) Power: Humidity: 60 %
EUT: 7 Inch Tablet PC Distance: 3m
M/N: TPC7026C
Mode: 802.11b High channel TX
Note:

No.	Mk	Freq.	Reading	Factor	Measurement	Limit	Over	Detector	Antenna Height	Table Degree	Comment
		MHz	dBuV	dB/m	dBuV/m	dBuV/m	dB		cm	degree	
1	*	2462.082	77.99	0.00	77.99	74.00	3.99	peak			
2		2483.500	30.63	0.00	30.63	74.00	-43.37	peak			
3		2526.400	35.14	0.00	35.14	74.00	-38.86	peak			
4		2566.133	35.13	0.00	35.13	74.00	-38.87	peak			

RESULT: PASS

Note: the other modes radiation emission have enough 20dB margin.

Measurement= Reading + Factor, Over=Measure-Limit.

13. FCC LINE CONDUCTED EMISSION TEST

13.1. LIMITS OF LINE CONDUCTED EMISSION TEST

Frequency	Maximum RF Line Voltage	
	Q.P.(dBuV)	Average(dBuV)
150kHz~500kHz	66-56	56-46
500kHz~5MHz	56	46
5MHz~30MHz	60	50

Note:

1. The lower limit shall apply at the transition frequency.
2. The limit decreases linearly with the logarithm of the frequency in the range 0.15 MHz to 0.50 MHz.

13.2. BLOCK DIAGRAM OF LINE CONDUCTED EMISSION TEST

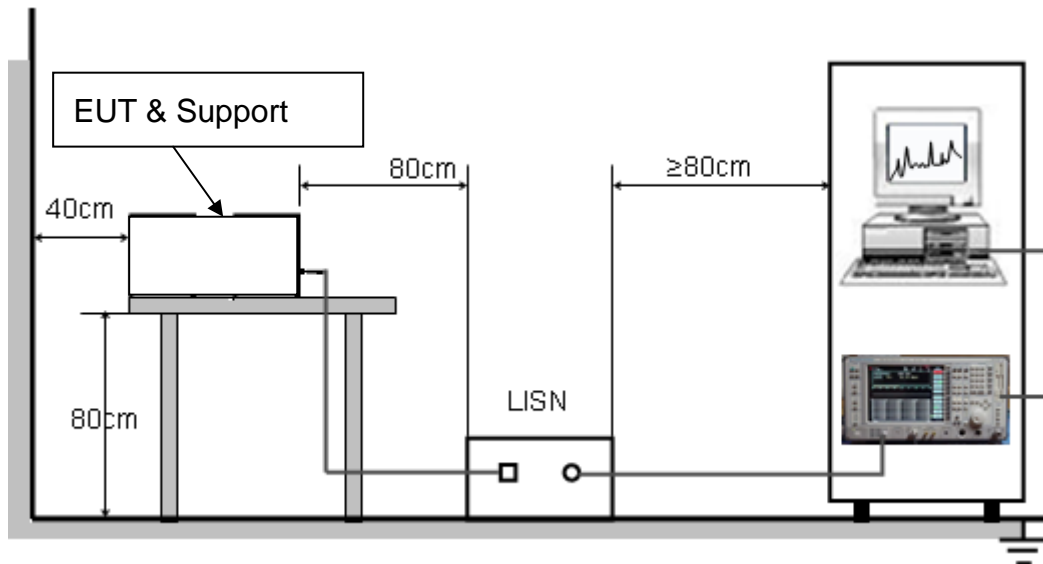

13.3. PRELIMINARY PROCEDURE OF LINE CONDUCTED EMISSION TEST

1. The equipment was set up as per the test configuration to simulate typical actual usage per the user's manual. When the EUT is a tabletop system, a wooden table with a height of 0.8 meters is used and is placed on the ground plane as per ANSI C63.4 (see Test Facility for the dimensions of the ground plane used). When the EUT is a floor-standing equipment, it is placed on the ground plane which has a 3-12 mm non-conductive covering to insulate the EUT from the ground plane.
2. Support equipment, if needed, was placed as per ANSI C63.4.
3. All I/O cables were positioned to simulate typical actual usage as per ANSI C63.4.
4. All support equipments received AC120V/60Hz power from a LISN, if any.
5. The EUT received DC5V charging voltage by adapter which received 120V/60Hz power by a LISN..
6. The test program was started. Emissions were measured on each current carrying line of the EUT using a spectrum Analyzer / Receiver connected to the LISN powering the EUT. The LISN has two monitoring points: Line 1 (Hot Side) and Line 2 (Neutral Side). Two scans were taken: one with Line 1 connected to Analyzer / Receiver and Line 2 connected to a 50 ohm load; the second scan had Line 1 connected to a 50 ohm load and Line 2 connected to the Analyzer / Receiver.
7. Analyzer / Receiver scanned from 150 kHz to 30MHz for emissions in each of the test modes.
8. During the above scans, the emissions were maximized by cable manipulation.
9. The test mode(s) were scanned during the preliminary test.

Then, the EUT configuration and cable configuration of the above highest emission level were recorded for reference of final testing.

13.4. FINAL PROCEDURE OF LINE CONDUCTED EMISSION TEST

1. EUT and support equipment was set up on the test bench as per step 2 of the preliminary test.
2. A scan was taken on both power lines, Line 1 and Line 2, recording at least the six highest emissions. Emission frequency and amplitude were recorded into a computer in which correction factors were used to calculate the emission level and compare reading to the applicable limit. If EUT emission level was less -2dB to the A.V. limit in Peak mode, then the emission signal was re-checked using Q.P and Average detector.
3. The test data of the worst case condition(s) was reported on the Summary Data page.

13.5. TEST RESULT OF LINE CONDUCTED EMISSION TEST

LINE CONDUCTED EMISSION TEST LINE 1-L

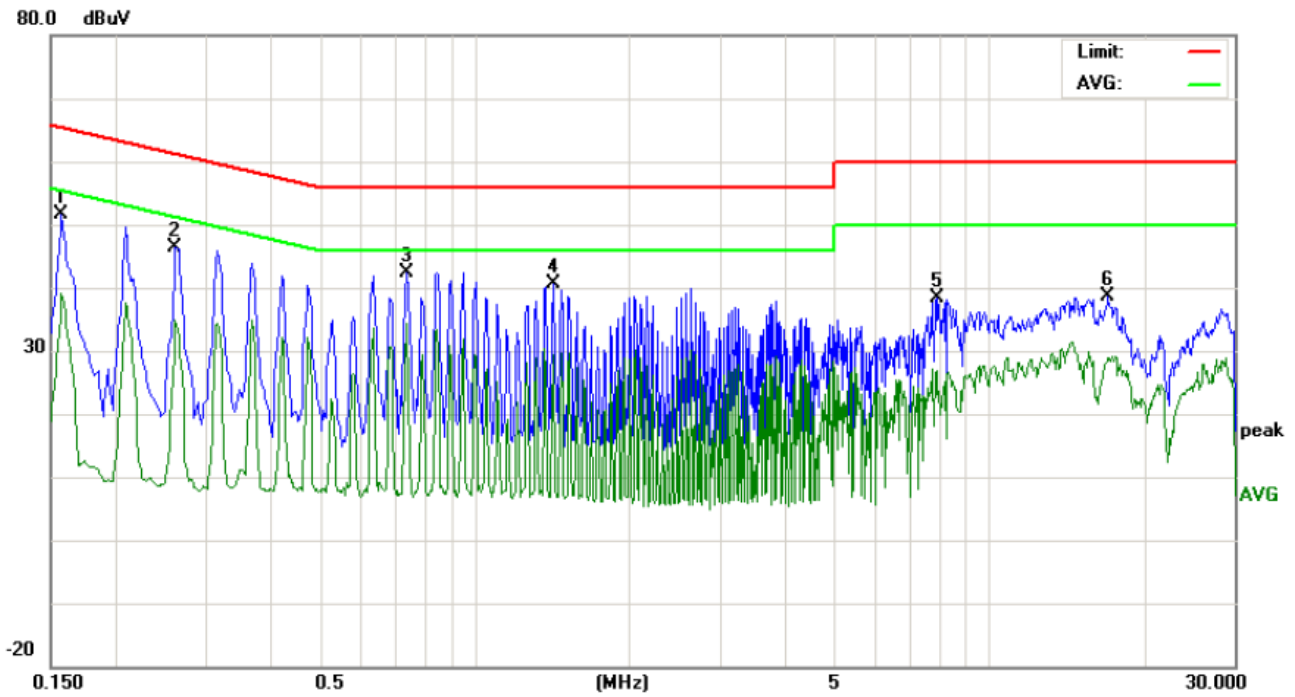

Site: Conduction Phase: **L1** Temperature: 26
 Limit: FCC Class B Conduction(QP) Power: Humidity: 60 %
 EUT: 7 Inch Tablet PC
 M/N: TPC7026C
 Mode: Normal Operating(WiFi)
 Note:

No.	Freq. (MHz)	Reading_Level (dBuV)			Correct Factor (dB)	Measurement (dBuV)			Limit (dBuV)		Margin (dB)		P/F	Comment
		Peak	QP	AVG		Peak	QP	AVG	QP	AVG	QP	AVG		
1	0.1580	41.53		28.85	10.17	51.70		39.02	65.56	55.56	-13.86	-16.54	P	
2	0.2620	36.18		24.59	10.27	46.45		34.86	61.36	51.36	-14.91	-16.50	P	
3	0.7380	32.11		24.02	10.32	42.43		34.34	56.00	46.00	-13.57	-11.66	P	
4	1.4220	30.25		18.57	10.38	40.63		28.95	56.00	46.00	-15.37	-17.05	P	
5	7.9140	27.96		16.50	10.35	38.31		26.85	60.00	50.00	-21.69	-23.15	P	
6	17.1060	28.38		18.75	10.13	38.51		28.88	60.00	50.00	-21.49	-21.12	P	

Line Conducted Emission Test Line 2-N

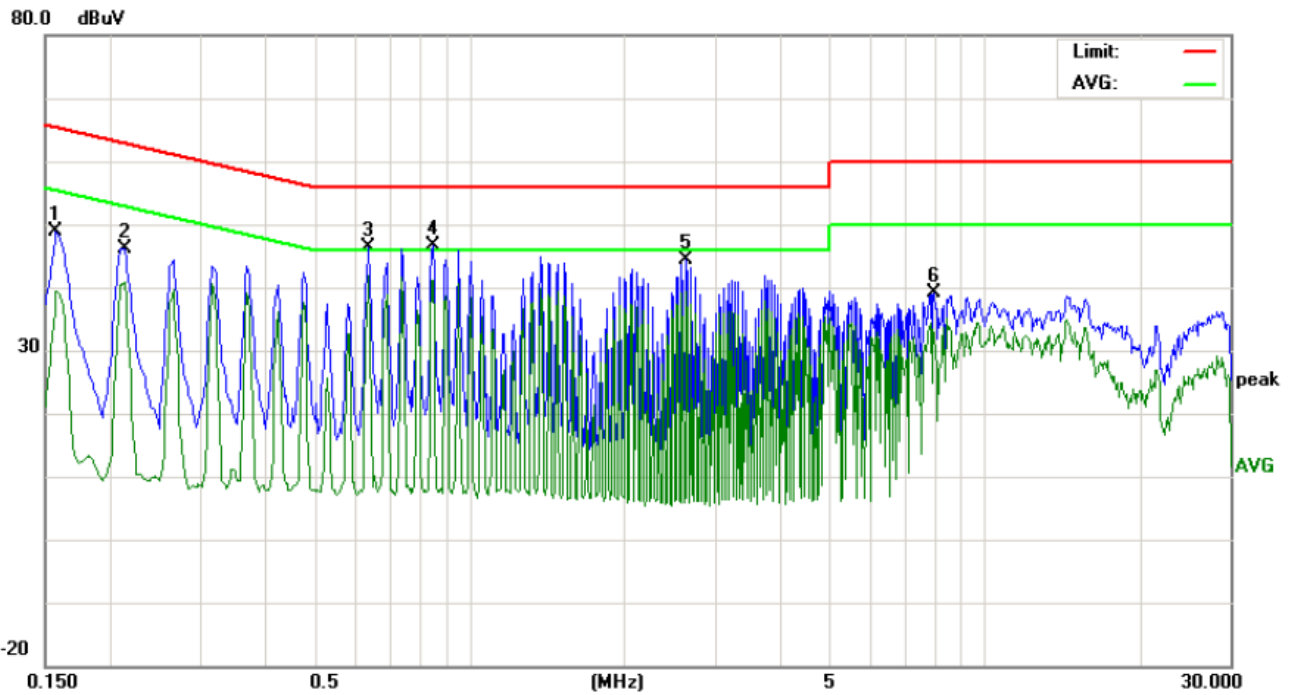

Site: Conduction Phase: **N** Temperature: 26
Limit: FCC Class B Conduction(QP) Power: Humidity: 60 %
EUT: 7 Inch Tablet PC
M/N: TPC7026C
Mode: Normal Operating(WiFi)
Note:

No.	Freq. (MHz)	Reading_Level (dBuV)			Correct Factor (dB)	Measurement (dBuV)			Limit (dBuV)		Margin (dB)		P/F	Comment
		Peak	QP	AVG		Peak	QP	AVG	QP	AVG	QP	AVG		
1	0.1580	38.77		29.31	10.17	48.94		39.48	65.56	55.56	-16.62	-16.08	P	
2	0.2140	35.85		30.54	10.23	46.08		40.77	63.04	53.04	-16.96	-12.27	P	
3	0.6380	36.10		31.58	10.33	46.43		41.91	56.00	46.00	-9.57	-4.09	P	
4	0.8500	36.38		30.67	10.34	46.72		41.01	56.00	46.00	-9.28	-4.99	P	
5	2.6460	33.79		29.03	10.46	44.25		39.49	56.00	46.00	-11.75	-6.51	P	
6	7.9940	28.69		22.45	10.35	39.04		32.80	60.00	50.00	-20.96	-17.20	P	

APPENDIX A: PHOTOGRAPHS OF TEST SETUP
FCC LINE CONDUCTED EMISSION TEST SETUP



FCC RADIATED EMISSION TEST SETUP

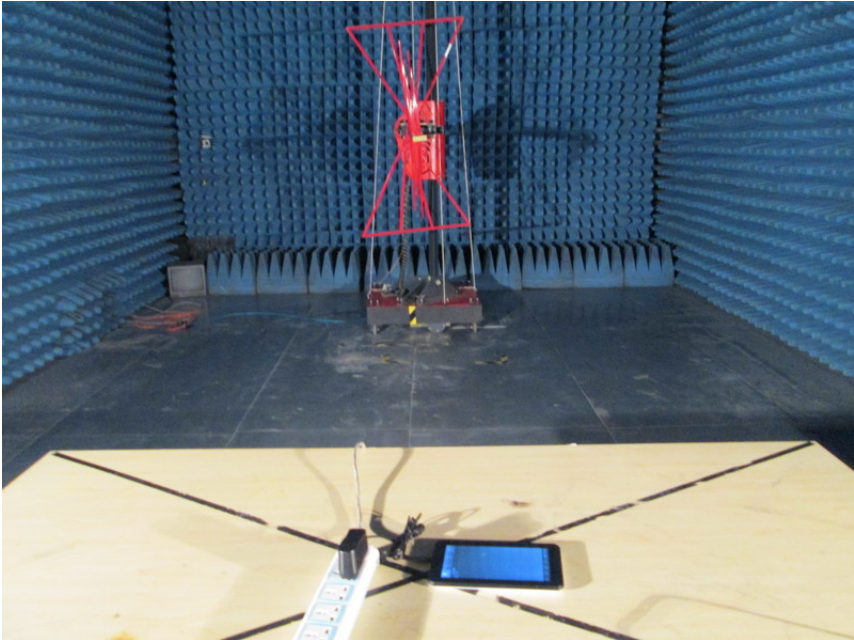

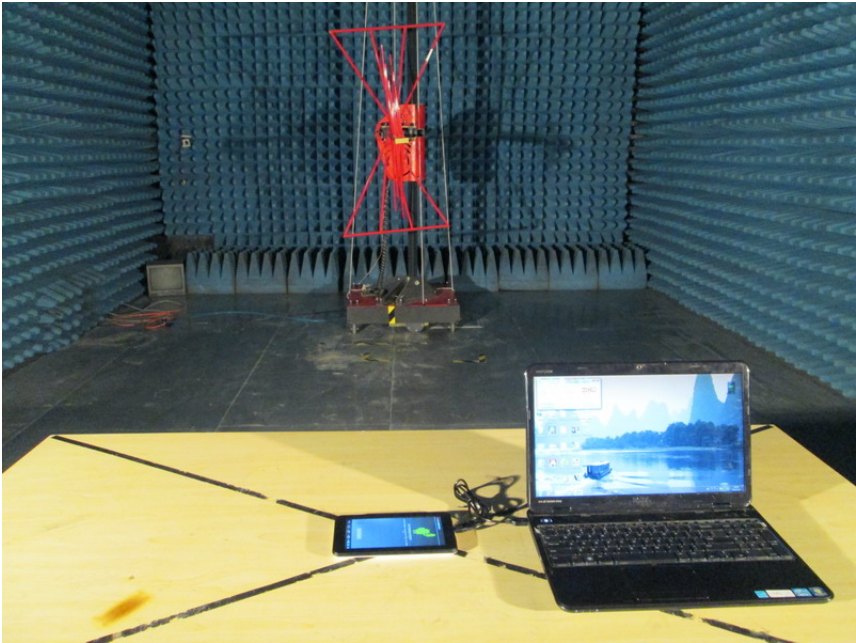

APPENDIX B: PHOTOGRAPHS OF EUT TOTAL VIEW OF EUT



TOP VIEW OF EUT



BOTTOM VIEW OF EUT



FRONT VIEW OF EUT



BACK VIEW OF EUT



LEFT VIEW OF EUT



RIGHT VIEW OF EUT



INTERNAL VIEW OF EUT-1

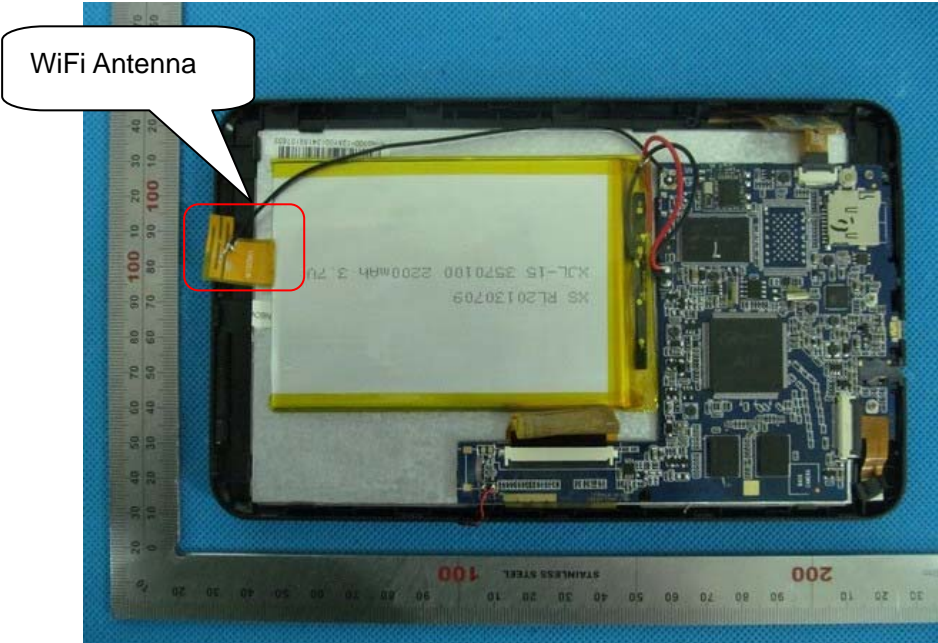

INTERNAL VIEW OF EUT-2

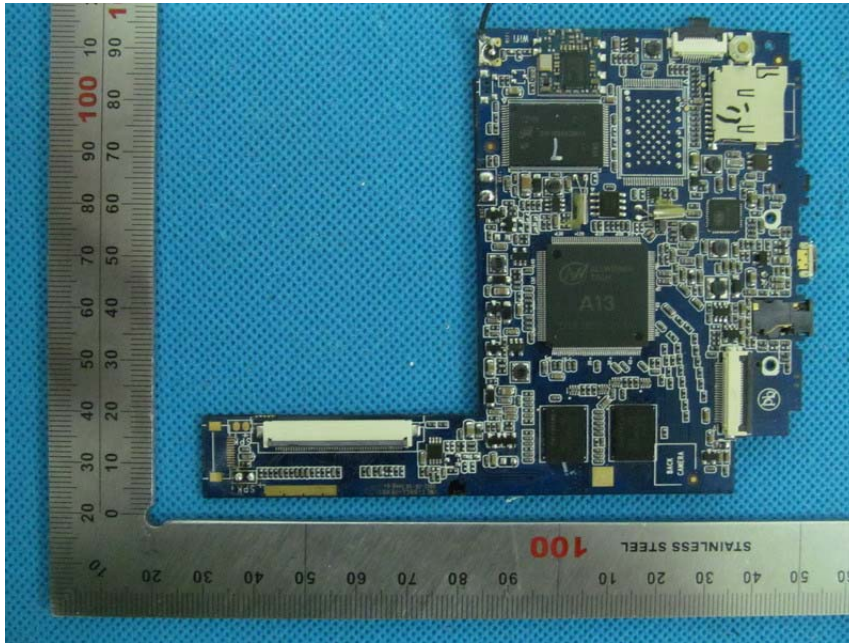

INTERNAL VIEW OF EUT-3

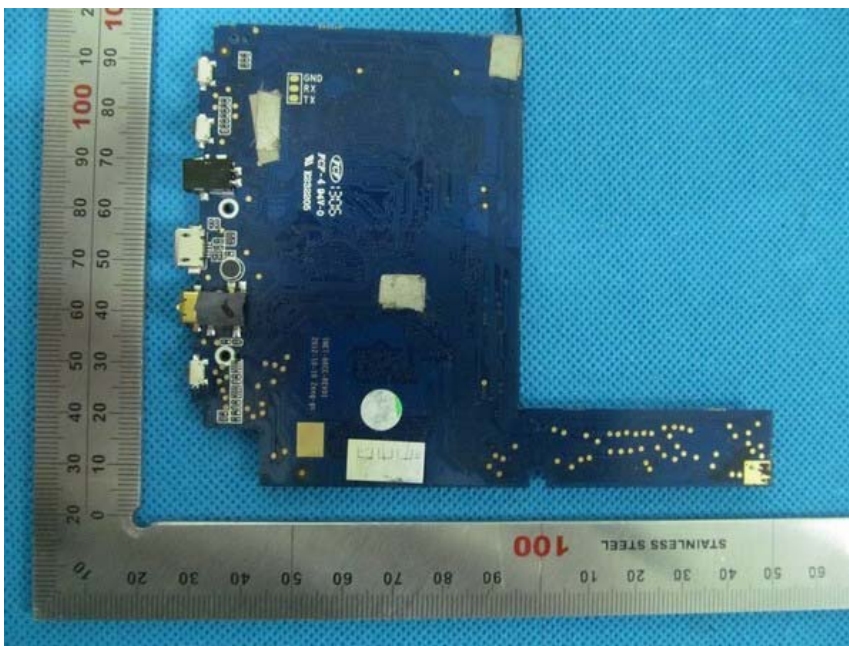

-----END OF REPORT-----