



EMC TEST REPORT for Intentional Radiator No. 131000486SHA-002

Applicant : Ecovacs Robotics Co.,Ltd.
No.108 Shihu Road (West), Wuzhong Zone, Suzhou ,
China |215168

Manufacturer : Ecovacs Robotics Co.,Ltd.
No.108 Shihu Road (West), Wuzhong Zone, Suzhou ,
China |215168

Product Name : 2.4G module

Type/Model : LSD4RF-25410N15

SUMMARY

The equipment complies with the requirements according to the following standard(s):

47CFR Part 15 (2013): Radio Frequency Devices

ANSI C63.4 (2009): American National Standard for Methods of Measurement of Radio-Noise Emissions from Low-Voltage Electrical and Electronic Equipment in the Range of 9 kHz to 40 GHz

RSS-210 Issue 8 (December 2010): Low-power Licence-exempt Radiocommunication Devices (All Frequency Bands): Category I Equipment

RSS-Gen Issue 3 (December 2010): General Requirements and Information for the Certification of Radiocommunication Equipment

Date of issue: November 27, 2014

Prepared by:

Reviewed by:

Jackson Huang (*Project Engineer*)

Daniel Zhao (*Reviewer*)



FCC ID: 2AAL3-LSD4RF
IC: 12253A-LSD4RF

Description of Test Facility

Name: Intertek Testing Services Limited Shanghai
Address: Building No.86, 1198 Qinzhou Road(North), Shanghai 200233, P.R. China

FCC Registration Number: 236597

Name of contact: Steve Li
Tel: +86 21 64956565 ext. 214
Fax: +86 21 54262335 ext. 214

Content

SUMMARY	1
DESCRIPTION OF TEST FACILITY	2
1. GENERAL INFORMATION	4
1.1 Applicant Information.....	4
1.2 Identification of the EUT	4
1.3 Technical specification	5
1.4 Mode of operation during the test / Test peripherals used.....	5
2. TEST SPECIFICATION	6
2.1 Instrument list	6
2.2 Test Standard	6
2.3 Test Summary	7
3. MINIMUM 6dB BANDWIDTH	8
3.1 Limit.....	8
3.2 Test Configuration	8
3.3 Test Procedure and test setup.....	8
3.4 Test Protocol	9
4. MAXIMUM PEAK OUTPUT POWER	11
4.1 Test limit	11
4.2 Test Configuration	11
4.3 Test procedure and test setup.....	11
4.4 Test protocol	12
5. POWER SPECTRUM DENSITY	13
5.1 Test limit	13
5.2 Test Configuration	13
5.3 Test procedure and test setup.....	13
5.4 Test Protocol	14
6. RADIATED EMISSION	16
6.1 Test limit	16
6.2 Test Configuration	16
6.3 Test procedure and test setup.....	17
6.4 Test protocol	18
7. EMISSION OUTSIDE THE FREQUENCY BAND	19
7.1 Limit.....	19
7.2 Test Configuration	19
7.3 Test procedure and test setup.....	19
7.4 Test protocol	20
8. POWER LINE CONDUCTED EMISSION	21
8.1 Limit.....	21
8.2 Test configuration	21
8.3 Test procedure and test set up.....	22
8.4 Test protocol	22
9. OCCUPIED BANDWIDTH	23
9.1 Test limit	23
9.2 Test Configuration	23
9.3 Test procedure and test setup.....	23
9.4 Test protocol	24



1. General Information

1.1 Applicant Information

Applicant : Ecovacs Robotics Co.,Ltd.
No.108 Shihu Road (West), Wuzhong Zone, Suzhou , China
215168

Name of contact : Ms. Geng Hongxia

Tel : 86 0512 67072006

Fax : 86 0512 65274820

Manufacturer : Ecovacs Robotics Co.,Ltd.
No.108 Shihu Road (West), Wuzhong Zone, Suzhou , China
215168

1.2 Identification of the EUT

Equipment: 2.4G module

Type/model: LSD4RF-25410N15

FCC ID: 2AAL3-LSD4RF

IC ID: 12253A-LSD4RF

1.3 Technical specification

Frequency Range: 2438.99 – 2458.98 MHz
 Modulation: 2-FSK
 Gain of Antenna: PCB antenna, 0 dBi
 Rating: 3.3VDC
 Description of EUT: The EUT is a 2.4GHz wireless module.
 Channel Description: 101Channel for 2438.99~2458.98MHz.
 The channel spacing is 200 kHz.

Channel	Frequency (MHz)
0	2438.99
1	2439.19
2	2439.38
.	.
.	.
.	.
100	2458.98

1.4 Mode of operation during the test / Test peripherals used

While testing transmitting mode of EUT, the internal modulation and continuously transmission was applied.

The lowest, middle and highest channel were tested as representatives.

Freq. Band	Lowest(MHz)	Middle(MHz)	Highest(MHz)
2438.99~2458.98MHz	2438.99	2448.98	2458.98

The data rate of EUT is fixed and cannot be adjusted.

Test software setting:

The test setting software is offered by the manufactory.

Test hardware setting:

Product	Model	Manufactory
Test Board	LSD4RMZJA0760V1.00	Lierda Science & Technology Group Co.,Ltd.

2. Test Specification

2.1 Instrument list

Equipment	Type	Manu.	Internal no.	Cal. Date	Due date
Test Receiver	ESCS 30	R&S	EC 2107	2013-10-21	2014-10-20
Test Receiver	ESIB 26	R&S	EC 3045	2013-10-21	2014-10-20
Test Receiver	ESCI 7	R&S	EC4501	2013-12-29	2014-12-28
Spectrum Analyzer	N9010	Agilent	EC4890	2013-10-21	2014-10-20
Power meter	ML 2495A	Anritsu	EC 4895	2013-10-21	2014-10-20
A.M.N.	ESH2-Z5	R&S	EC 3119	2014-1-9	2015-1-8
Bilog Antenna	CBL 6112D	TESEQ	EC 4206	2014-5-16	2015-5-15
Horn antenna	HF 906	R&S	EC 3049	2014-5-13	2015-5-12
Pre-amplifier	Pre-amp 18	R&S	EC 3222	2014-4-12	2015-4-11
Pre-amplifier	Tpa0118-40	R&S	EC 4792-2	2014-4-12	2015-4-11
Log-period antenna	AT 1080	AR	EC 3044-7	2014-5-22	2015-5-21
Biconical antenna	3109PX	ETS	EC3564	2013-8-25	2014-8-24
Semi-anechoic chamber	-	Albatross project	EC 3048	2014-5-21	2015-5-20
Shielded room	-	Zhongyu	EC 2838	2014-1-12	2016-1-11
Shielded room	-	Zhongyu	EC 2839	2014-1-12	2016-1-11
High Pass Filter	WHKX 1.0/15G-10SS	Wainwright	EC4297-1	2014-2-1	2015-1-31
High Pass Filter	WHKX 2.8/18G-12SS	Wainwright	EC4297-2	2014-2-1	2015-1-31
High Pass Filter	WHKX 7.0/1.8G-8SS	Wainwright	EC4297-3	2014-2-1	2015-1-31
Band Reject Filter	WRCGV 2400/2483-2390/2493-35/10SS	Wainwright	EC4297-4	2014-2-1	2015-1-31

2.2 Test Standard

47CFR Part 15 (2013)
ANSI C63.4 (2009)
RSS-210 Issue 8 (December 2010)
RSS-Gen Issue 3 (December 2010)

2.3 Test Summary

This report applies to tested sample only. This report shall not be reproduced in part without written approval of Intertek Testing Service Shanghai.

TEST ITEM	FCC REFERANCE	FCC REFERANCE	RESULT
Minimum 6dB Bandwidth	15.247(a)(2)	RSS-210 Issue 8 Annex 8	Pass
Maximum peak output power	15.247(b)	RSS-210 Issue 8 Annex 8	Pass
Power spectrum density	15.247(e)	RSS-210 Issue 8 Annex 8	Pass
Radiated emission	15.205 & 15.209	RSS-210 Issue 8 Clause 2	Pass
Emission outside the frequency band	15.247(d)	RSS-210 Issue 8 Annex 8	Pass
Power line conducted emission	15.207	RSS-Gen Issue 3 Clause 7.2.4	Pass
Occupied bandwidth	-	RSS-Gen Issue 3 Clause 4.6.1	Tested

3. Minimum 6dB Bandwidth

Test result: PASS

3.1 Limit

For systems using digital modulation techniques that may operate in the 902 - 928 MHz, 2400 - 2483.5 MHz and 5725 - 5850 MHz bands, the minimum 6 dB bandwidth shall be at least 500 kHz.

3.2 Test Configuration

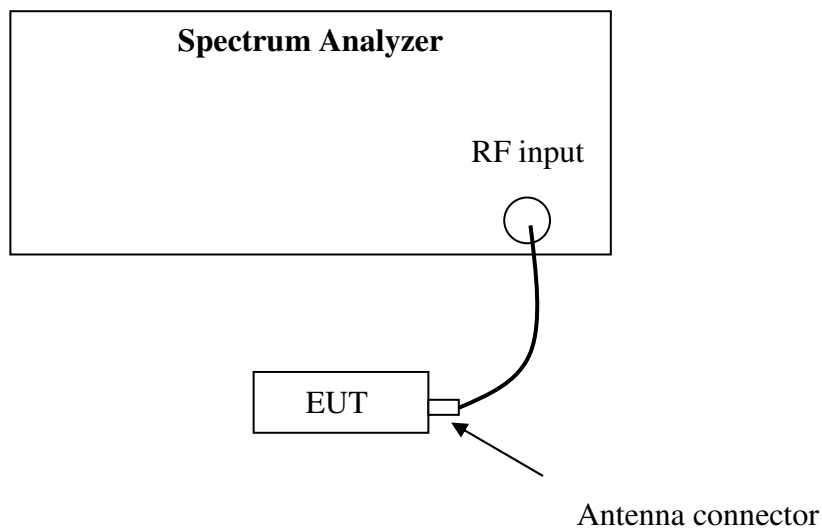

3.3 Test Procedure and test setup

The minimum 6dB bandwidth per FCC §15.247(a)(2) is measured using the Spectrum Analyzer according to DTS test procedure of “KDB558074 D01 DTS Meas Guidance v03r01” for compliance to FCC 47CFR 15.247 requirements.

3.4 Test Protocol

Temperature : 25°C
Relative Humidity : 55%

CH	Bandwidth (MHz)	Limit (MHz)
L	0.72	≥0.5
M	0.71	
H	0.69	

Frequency L

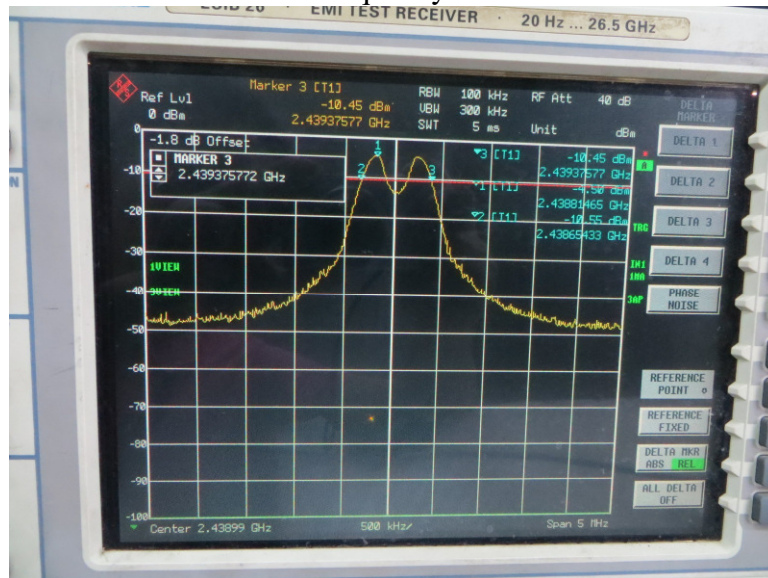

Frequency M

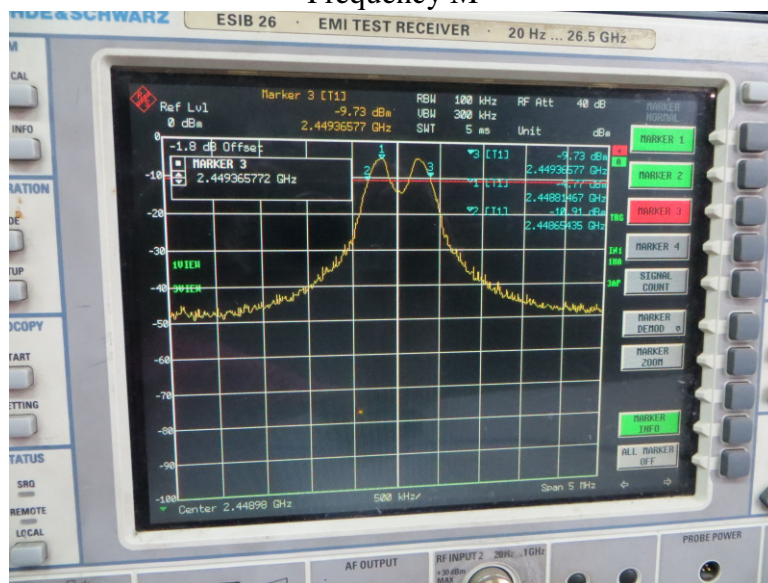

Frequency H

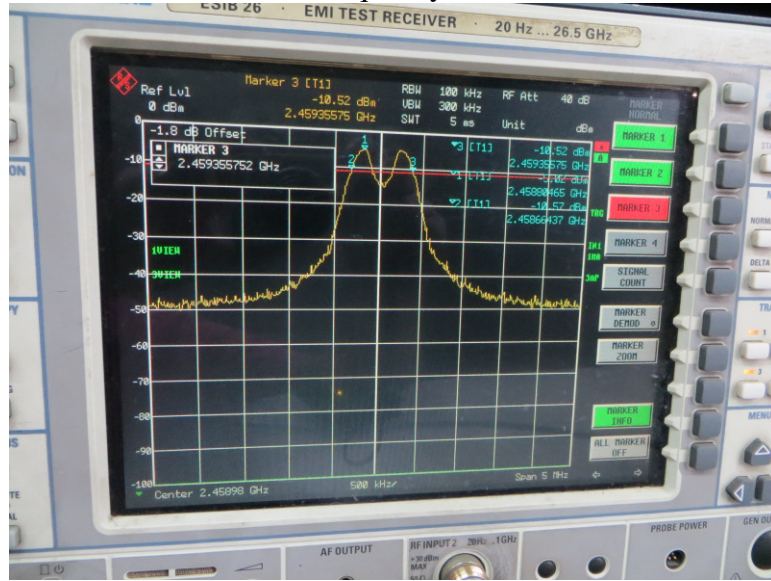

4. Maximum peak output power

Test result: Pass

4.1 Test limit

- For frequency hopping systems operating in the 2400-2483.5 MHz band employing at least 75 non-overlapping hopping channels, and all frequency hopping systems in the 5725-5850 MHz band: 1 watt
- For all other frequency hopping systems in the 2400-2483.5 MHz band: 0.125 watts
- For systems using digital modulation in the 902-928 MHz, 2400-2483.5 MHz, and 5725-5850 MHz bands: 1 Watt.

If the transmitting antenna of directional gain greater than 6dBi is used, the power shall be reduced by the amount in dB that the directional gain of the antenna exceeds 6dBi.

4.2 Test Configuration

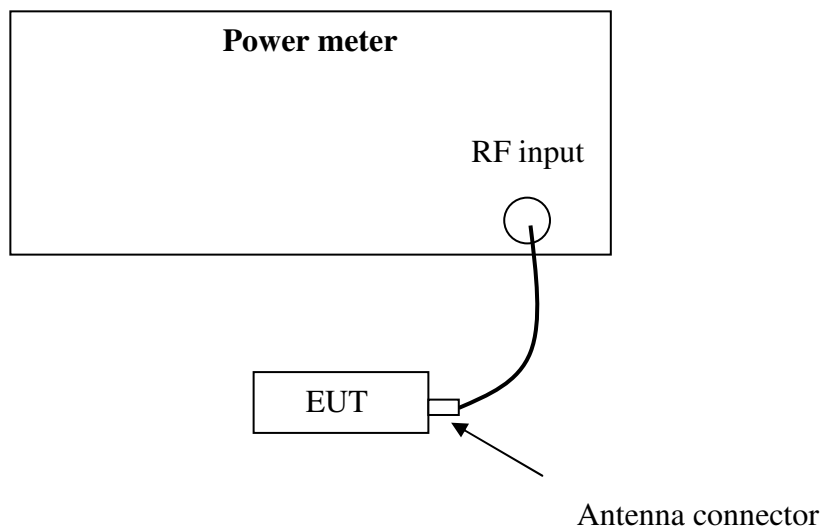

4.3 Test procedure and test setup

The EUT was tested according to DTS test procedure of “KDB558074 D01 DTS Meas Guidance v03r01” for compliance to FCC 47CFR 15.247 requirements (clause 9.1.2).



4.4 Test protocol

Temperature : 25 °C

Relative Humidity : 55 %

Freq. (MHz)	Reading (dBm)	Limit (dBm)	Margin (dB)
2438.99	3.57	30.00	26.43
2448.98	3.84	30.00	26.16
2458.98	3.29	30.00	26.71

5. Power spectrum density

Test result: Pass

5.1 Test limit

For digitally modulated systems, the power spectral density conducted from the intentional radiator to the antenna shall not be greater than 8dBm in any 3 kHz band during any time interval of continuous transmission.

5.2 Test Configuration

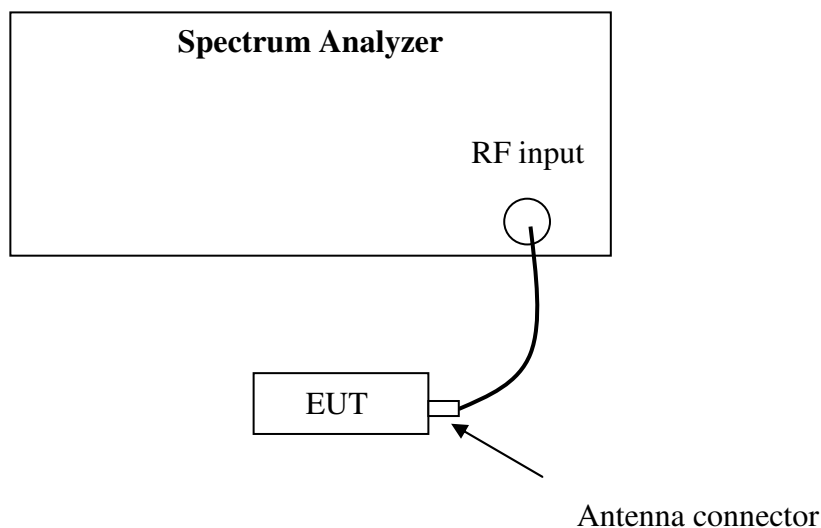

5.3 Test procedure and test setup

The power output per FCC §15.247(e) was tested according to DTS test procedure of “KDB558074 D01 DTS Meas Guidance v03r01” (clause 10.2) for compliance to FCC 47CFR 15.247 requirements.

5.4 Test Protocol

Temperature : 25 °C

Relative Humidity: 55 %

CH	Cable loss (dB)	PSD (dBm/100kHz)	Limit (dBm/3kHz)
L	2.00	-4.50	≤8.00
M	2.00	-4.78	
H	2.00	-4.92	

Frequency L

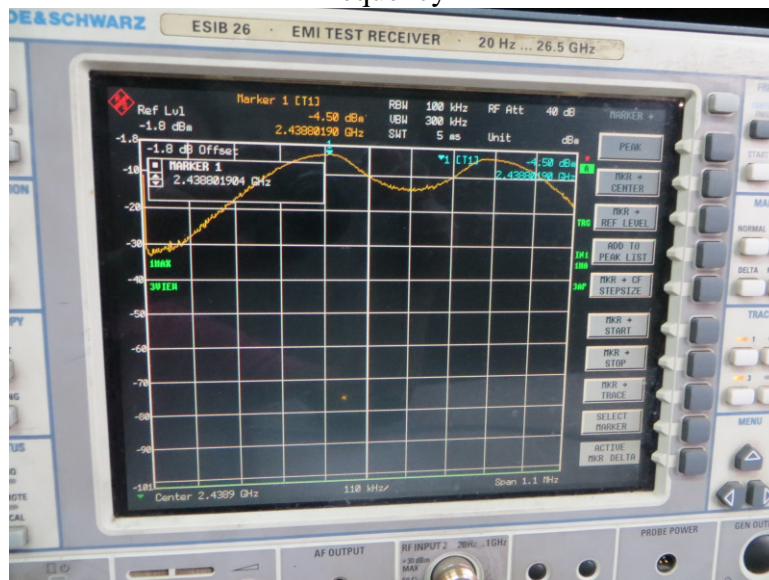

Frequency M

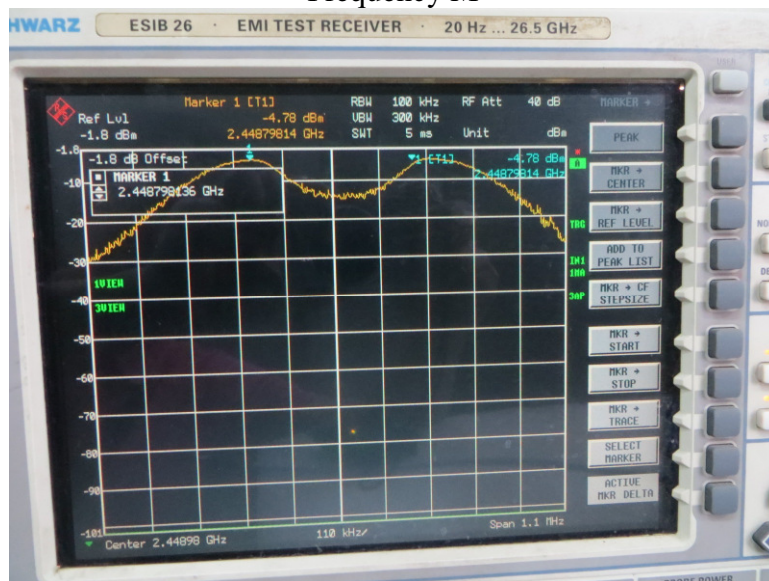

Frequency H

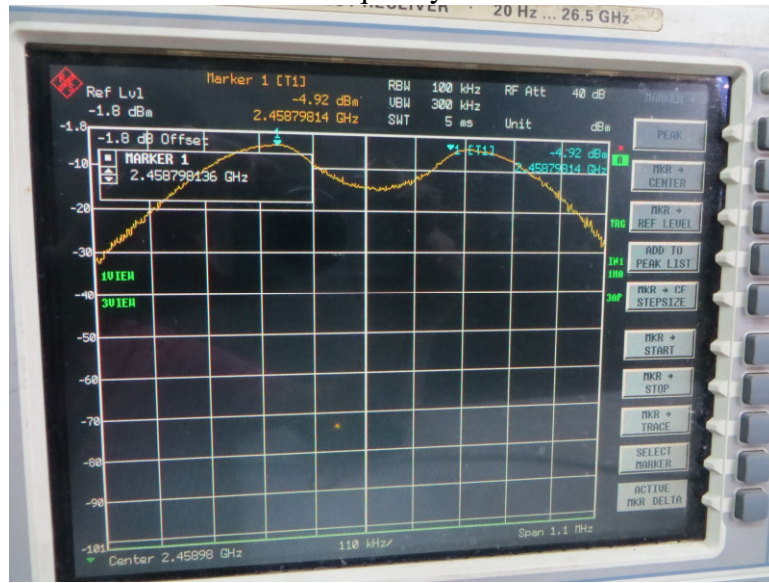

6. Radiated emission

Test result: **PASS**

6.1 Test limit

The radiated emissions which fall in the restricted bands, as defined in §15.205(a), must also comply with the radiated emission limits specified in §15.209(a) showed as below:

Frequency (MHz)	Field Strength (dBuV/m)	Measurement Distance (m)
30 - 88	40.0	3
88 - 216	43.5	3
216 - 960	46.0	3
Above 960	54.0	3

6.2 Test Configuration

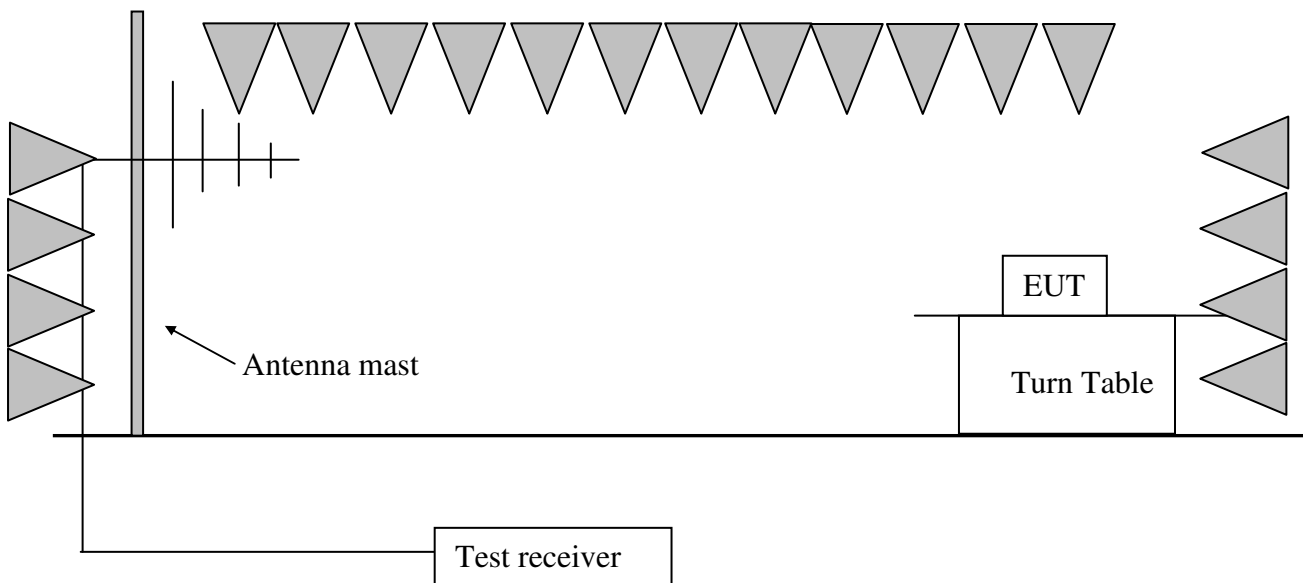

6.3 Test procedure and test setup

The measurement was applied in a semi-anechoic chamber. While testing for spurious emission higher than 1GHz, if applied, the pre-amplifier would be equipped just at the output terminal of the antenna.

The EUT and simulators were placed on a 0.8m high wooden turntable above the horizontal metal ground plane. The turn table rotated 360 degrees to determine the position of the maximum emission level. The EUT was set 3 meters away from the receiving antenna which was mounted on an antenna mast. The antenna moved up and down between from 1meter to 4 meters to find out the maximum emission level.

The EUT was tested according to DTS test procedure of KDB558074 D01 DTS “Meas Guidance v03r01” (clause 12.1) for compliance to FCC 47CFR 15.247 requirements.

6.4 Test protocol

Temperature : 18 °C
Relative Humidity : 54 %

We test from 30M~26GHz and list the worst data below.

CH	Polarization	Frequency	Factor	Measure Level	Limit	Over Limit	Type
		(MHz)		(dBuV/m)	(dBuV/m)	(dB)	
L	V	2438.99	-11.6	73.2	Fundamental	/	PK
	H	156.35	14.0	25.7	43.5	17.8	QP
	H	311.86	25.3	31.8	46.0	14.2	QP
	V	2385.45	-10.9	34.3	54.0	9.7	PK
	V	4877.98	-3.4	51.1	74.0	22.9	PK
	V	4877.98	-3.4	48.9	54.0	5.1	AV
M	V	2448.98	-11.6	74.0	Fundamental	/	PK
	V	4897.96	-3.3	50.0	74.0	24.0	PK
	V	4897.96	-3.3	47.5	54.0	6.5	AV
H	V	2458.98	-3.5	74.50	Fundamental	/	PK
	V	155.99	14.0	24.9	43.5	28.6	QP
	V	312.05	24.8	32.5	46.0	13.5	QP
	V	2484.00	-10.9	34.5	54.0	9.5	PK
	V	4917.96	-3.3	52.6	74.0	21.4	PK
	V	4917.96	-3.3	48.5	54.0	5.5	AV

- Remark: 1. Factor = Antenna Factor + Cable Loss (-Amplifier, is employed)
 2. Measure level = Original Receiver Reading Level+ Correct Factor
 3. Over Limit = Measure level - limit
 4. If the PK reading is lower than AV limit, the AV test can be elided.

Example: Assuming Antenna Factor = 30.20dB/m, Cable Loss = 2.00dB,
 Gain of Preamplifier = 32.00dB, Original Receiver Reading level = 10dBuV.
 Then Factor = 30.20 + 2.00 – 32.00 = 0.20dB/m; Measure level = 10dBuV +
 0.20dB/m = 10.20dBuV/m
 Assuming limit = 54dBuV/m, Measure level = 10.20dBuV/m, then Over Limit =
 10.20 - 54= -43.80dBuV/m

7. Emission outside the frequency Band

Test result: PASS

7.1 Limit

In any 100 kHz bandwidth outside the frequency band in which the spread spectrum intentional radiator is operating, the radio frequency power that is produced by the intentional radiator shall be at least 20 dB below that in the 100 kHz bandwidth within the band that contains the highest level of the desired power.

7.2 Test Configuration

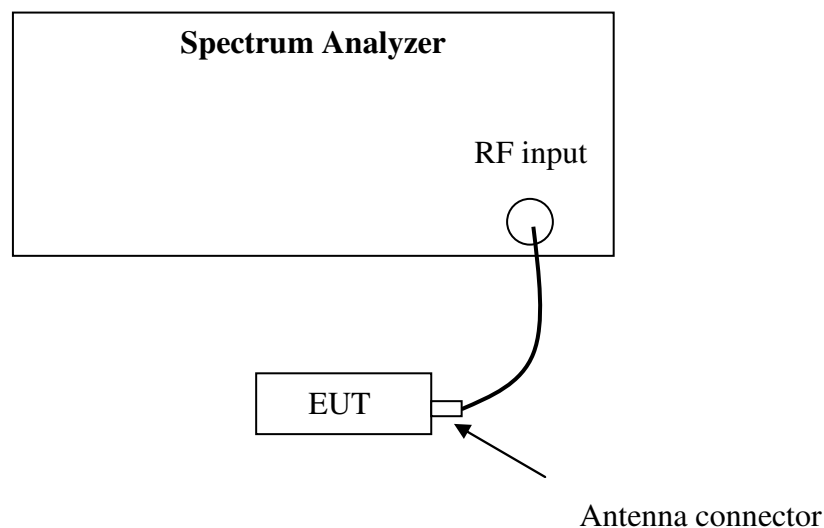

7.3 Test procedure and test setup

The Emission outside the frequency Band per FCC §15.247(d) is measured using the Spectrum Analyzer with the resolutions bandwidth set at 100kHz, the video bandwidth set at 300kHz, and the SPAN>>RBW.

The EUT was tested according to DTS test procedure of “KDB558074 D01 DTS Meas Guidance v03r01” (clause 11.0) for compliance to FCC 47CFR 15.247 requirements.

7.4 Test protocol

CH	Max reading among band (dBm)	The most restrict Attenuation outside band (dB)	Limit (dB)
L	-4.77	41.87	≥20
H	-5.09	42.65	

Note: The test was performed from 9kHz to 26GHz and the graph of band edge emission is listed below.

Low Band Edge - Frequency L

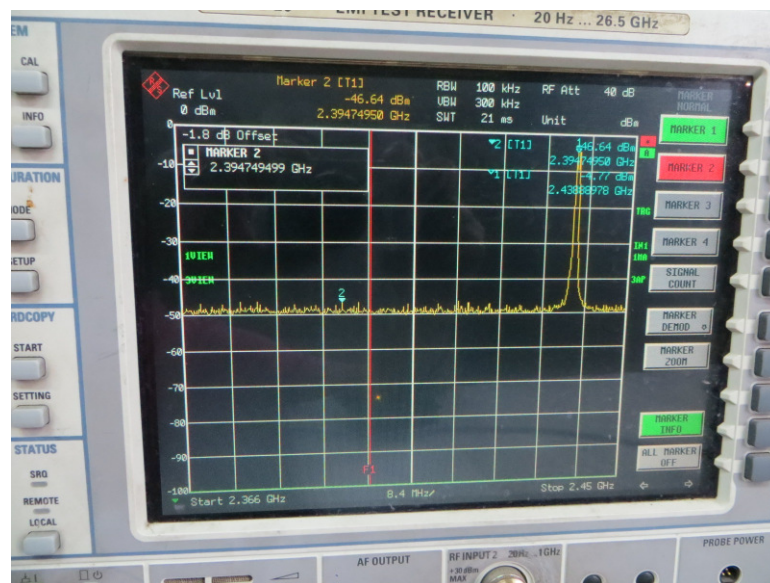

High Band Edge - Frequency H

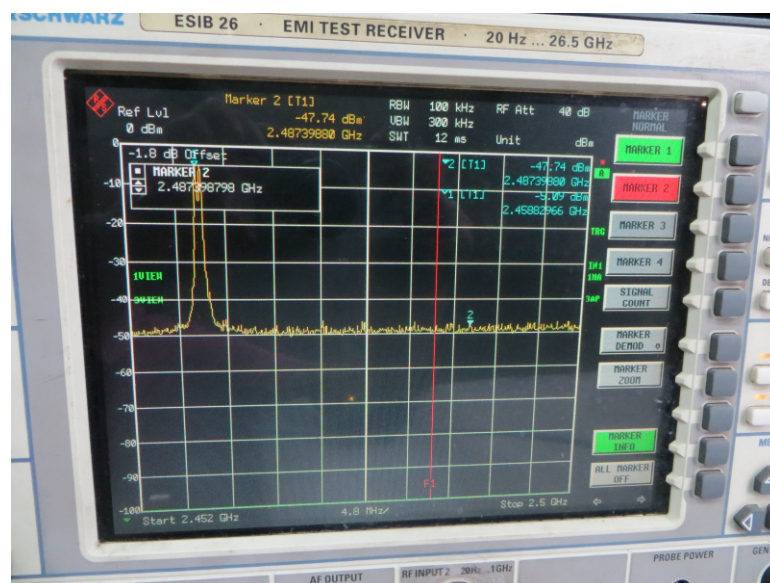

8. Power line conducted emission

Test result: NA

8.1 Limit

Frequency of Emission (MHz)	Conducted Limit (dBuV)	
	QP	AV
0.15-0.5	66 to 56*	56 to 46 *
0.5-5	56	46
5-30	60	50

* Decreases with the logarithm of the frequency.

8.2 Test configuration

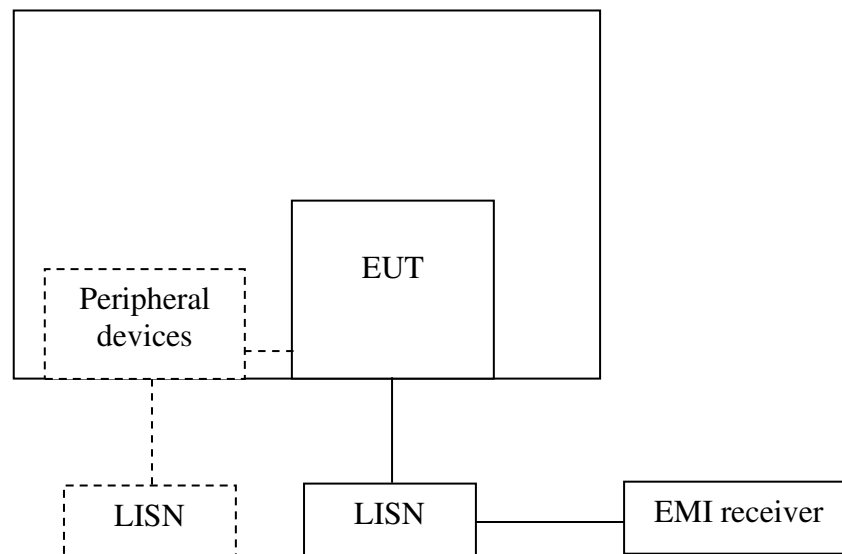

For table top equipment, wooden support is 0.8m height table

For floor standing equipment, wooden support is 0.1m height rack.

8.3 Test procedure and test set up

The EUT are connected to the main power through a line impedance stabilization network (LISN). This provides a $50\Omega/50\mu\text{H}$ coupling impedance for the measuring equipment. The peripheral devices are also connected to the main power through a LISN that provides a $50\Omega/50\mu\text{H}$ coupling impedance with 50Ω termination.

Both sides (Line and Neutral) of AC line are checked for maximum conducted interference. In order to find the maximum emission, the relative positions of equipment and all of the interface cables must be changed according to ANSI C63.4 on conducted measurement. The bandwidth of the test receiver is set at 9 kHz.

8.4 Test protocol

9. Occupied Bandwidth

Test Status: Tested

9.1 Test limit

None

9.2 Test Configuration

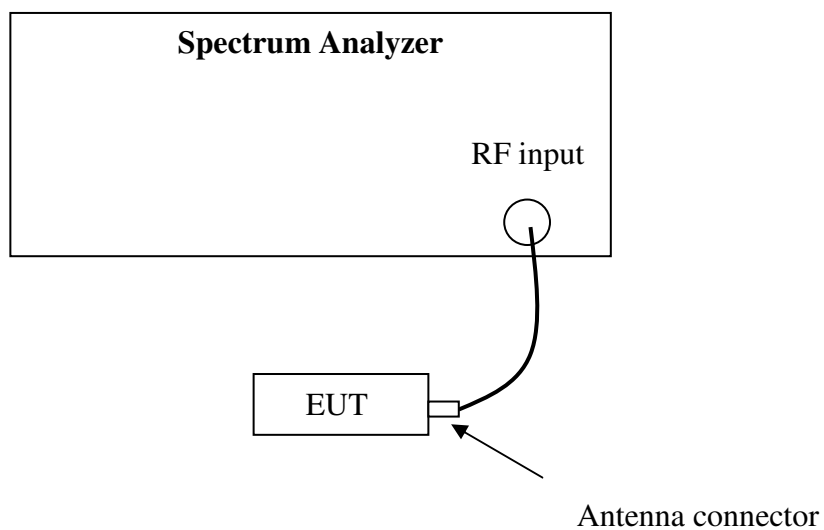

9.3 Test procedure and test setup

The occupied bandwidth per RSS-Gen Issue 3 Clause 4.6.1 was measured using the Spectrum Analyzer.

9.4 Test protocol

Temperature : 25 °C
Relative Humidity : 55 %

CH	99% Bandwidth (MHz)
L	3.26
M	3.32
H	3.28

Channel L

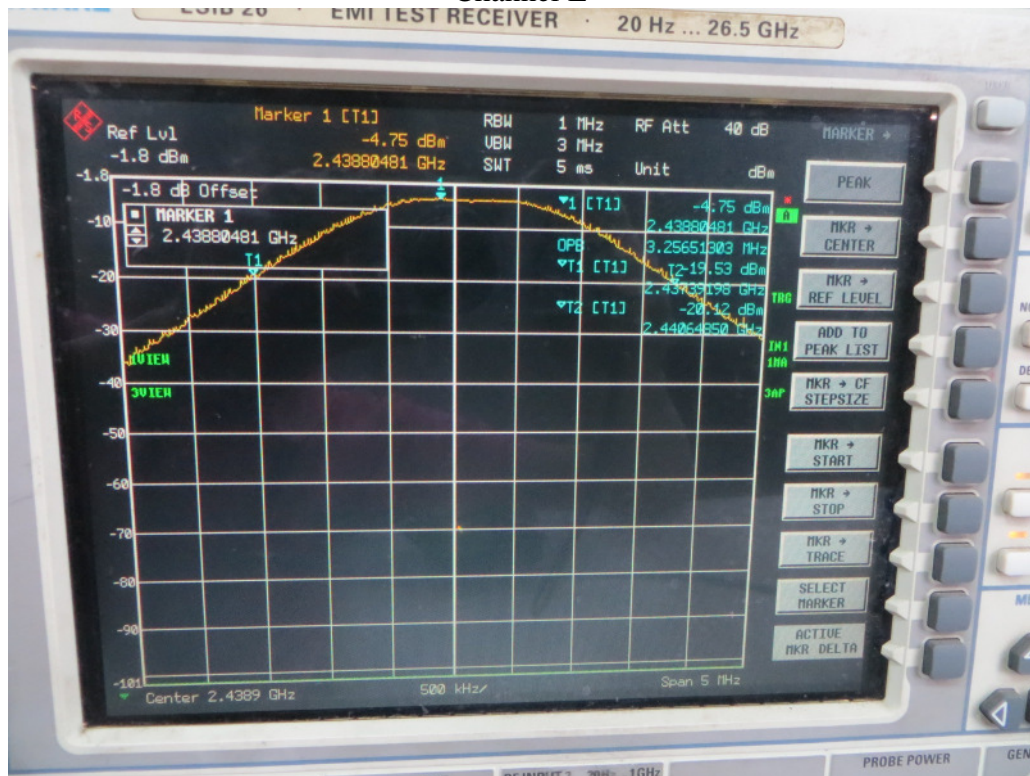

Channel M

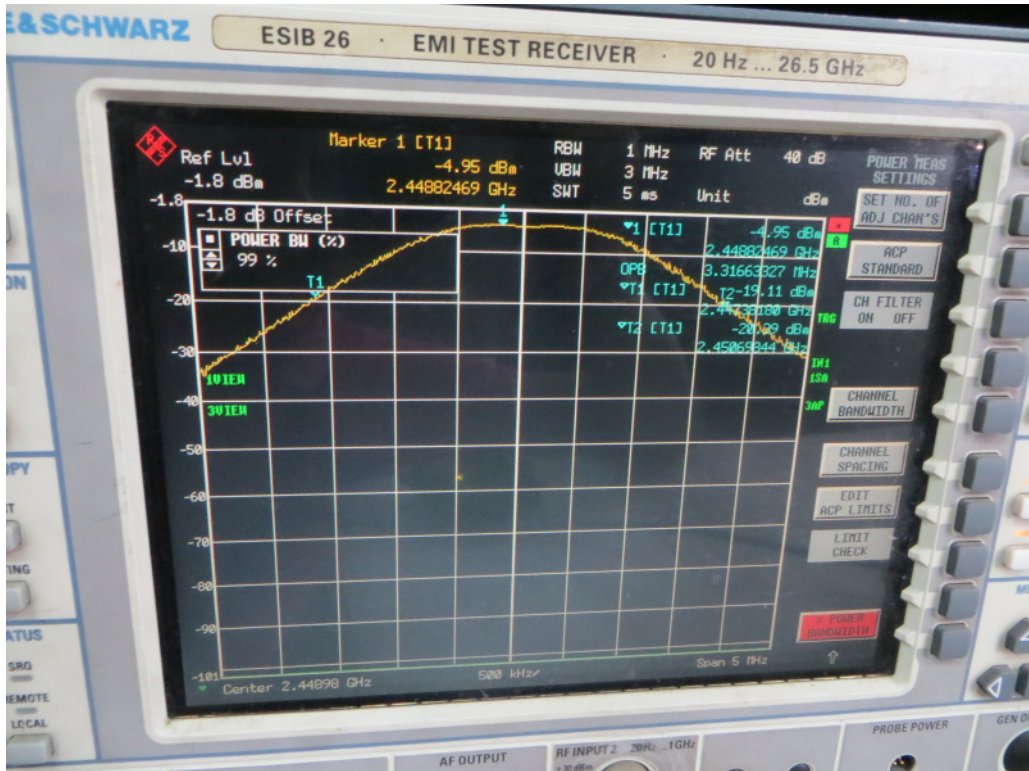

Channel H

