

	Typ	Min	Max
VCC:	3.3V	2.0V	3.6V
VDD:	3.3V	2.0V	3.6V
VCC_2591:	3.3V	2.0V	3.6V

CC2500 contains several on-chip linear voltage regulators, which generate the supply voltage needed by low-voltage modules.

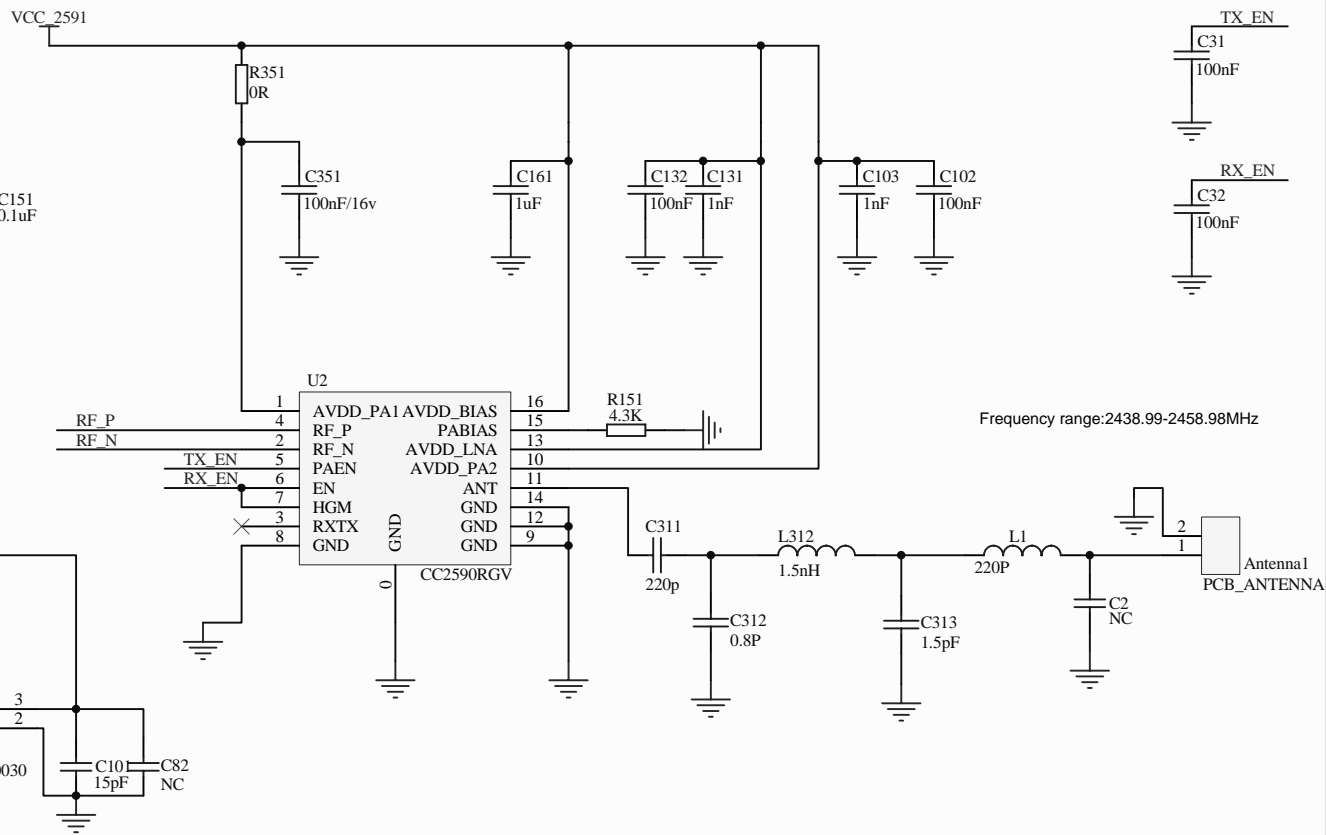

Frequency range: 2438.99-2458.98MHz

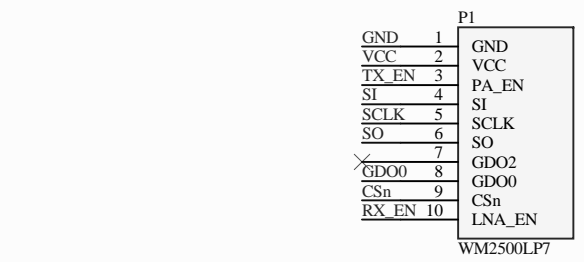
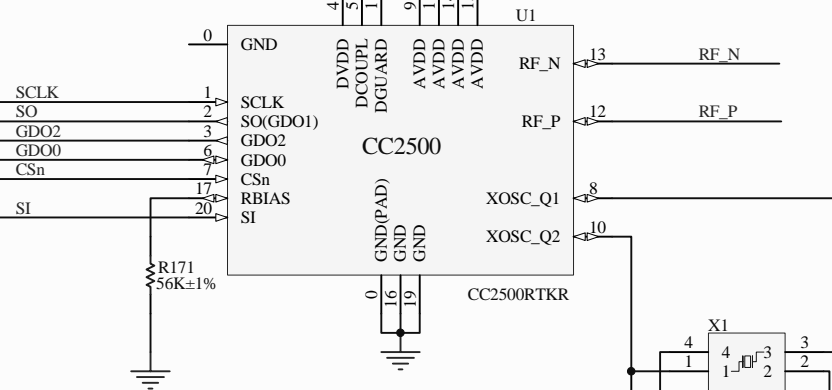
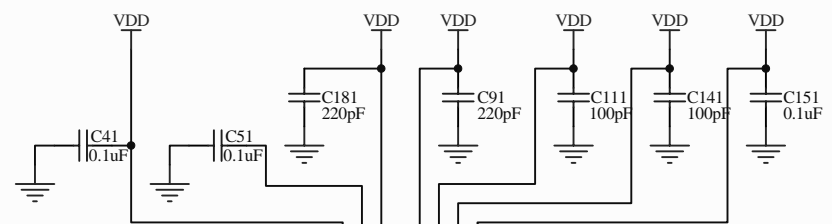
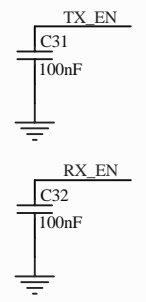

Title		
Size	Number	Revision
A4		
Date:	1 2014-12-29	Sheet of
File:	C:\Documents and Settings\...\LSD4RMZJX0220V330.sch	