

TEST REPORT

Report Number: 102374971MPK-002

Project Number: G102374971

March 25, 2016

Testing performed on the
IQ Panel 2 Home Security Panel
Models: IQPANEL2, IQPANEL2-ZW, IQPANEL2-ZB, IQPANEL2-ZZ
FCC ID: 2AAJXQS-IQPANEL2
IC: 11205A-QSIQPANEL2

to

FCC Part 15 Subpart C (15.247)
Industry Canada RSS-247, Issue 1

For

Qolsys, Inc.

Test Performed by:

Intertek

1365 Adams Court

Menlo Park, CA 94025 USA

Test Authorized by:

Qolsys, Inc.

1900 The Alameda #420

San Jose, CA 95126, USA

Prepared by:



Anderson Soungpanya

Date: March 25, 2016

Reviewed by:



Krishna K Vemuri

Date: March 25, 2016

This report is for the exclusive use of Intertek's Client and is provided pursuant to the agreement between Intertek and its Client. Intertek's responsibility and liability are limited to the terms and conditions of the agreement. Intertek assumes no liability to any party, other than to the Client in accordance with the agreement, for any loss, expense or damage occasioned by the use of this report. Only the Client is authorized to copy or distribute this report and then only in its entirety. Any use of the Intertek name or one of its marks for the sale or advertisement of the tested material, product or service must first be approved in writing by Intertek. The observations and test results in this report are relevant only to the sample tested. This report by itself does not imply that the material, product, or service is or has ever been under an Intertek certification program. This report must not be used to claim product endorsement by A2LA, NIST nor any other agency of the U.S. Government.

Report No. 102374971MPK-002

Equipment Under Test:	IQ Panel 2 Home Security Panel
Trade Name:	IQ Panel 2 Home Security Panel
Model Number:	IQPANEL2, IQPANEL2-ZW, IQPANEL2-ZB, IQPANEL2-ZZ
Serial Number:	QV903154300142AA & QV903154300152AA
Applicant:	Qolsys, Inc.
Contact:	Mark Skeen
Address:	Qolsys, Inc. 1900 The Alameda #420 San Jose, CA 95126
Country	USA
Tel. Number:	(408) 857-8415
Email:	Mark.Skeen@qolsys.com
Applicable Regulation:	FCC Part 15 Subpart C (15.247) Industry Canada RSS-247 Issue 1
Date of Test:	February 02 to March 09, 2016

We attest to the accuracy of this report:



Anderson Soungpanya
Project Engineer



Krishna K Vemuri
Engineering Team Lead

TABLE OF CONTENTS

1.0	Summary of Tests	4
2.0	General Information	5
2.1	Product Description.....	5
2.3	Test Methodology	6
2.4	Test Facility.....	6
2.5	Measurement Uncertainty	6
3.0	System Test Configuration.....	7
3.1	Support Equipment and description	7
3.2	Block Diagram of Test Setup	7
3.3	Justification	8
3.4	Mode of Operation During Test	9
3.5	Modifications Required for Compliance	9
3.6	Additions, Deviations and Exclusions from Standards	9
4.0	Measurement Results.....	10
4.1	6dB DTS Bandwidth, 6dB RSS Bandwidth and 99% Occupied Bandwidth	10
4.1.1	Requirement.....	10
4.1.2	Procedure	10
4.1.3	Test Result	11
4.2	Maximum Conducted Output Power at Antenna Terminals	36
4.2.1	Requirement.....	36
4.2.2	Procedure	36
4.2.3	Test Result	37
4.3	Power Spectral Density	47
4.3.1	Requirement.....	47
4.3.2	Procedure	47
4.3.3	Test Result	48
4.4	Out-of-Band Conducted Emissions.....	61
4.4.1	Requirement.....	61
4.4.2	Procedure	61
4.4.3	Test Result	61
4.5	Transmitter Radiated Emissions & Antenna Port Emissions.....	76
4.5.1	Requirement.....	76
4.5.2	Procedure – Radiated Emissions	76
4.5.3	Field Strength Calculation.....	77
4.5.4	Antenna-port conducted measurements.....	78
4.5.6	General Procedure for conducted measurements in restricted bands.....	78
4.5.7	Test Results	78
4.5.8	Test Setup Photographs.....	116
5.0	List of Test Equipment	117
6.0	Document History	118

1.0 Summary of Tests

Test	Reference FCC	Reference Industry Canada	Result
RF Output Power	15.247(b)(3)	RSS-247, 5.4	Complies
6 dB Bandwidth	15.247(a)(2)	RSS-247, 5.2	Complies
Power Density	15.247(e)	RSS-247, 5.2	Complies
Out of Band Antenna Conducted Emission	15.247(d)	RSS-247, 5.5	Complies
Transmitter Radiated Emissions	15.247(d), 15.209, 15.205	RSS-247, 5.5	Complies
AC Line Conducted Emission	15.207	RSS-GEN	Complies
Antenna Requirement	15.203	RSS-GEN	Complies (Unique Connector & Internal Antenna)
RF Exposure	15.247(i), 2.1093(d)	RSS-102	Complies

EUT receive date: January 18, 2016

EUT receive condition: The pre-production version of the EUT was received in good condition with no apparent damage. As declared by the Applicant, it is identical to the production units.

Test start date: February 02, 2016

Test completion date: March 09, 2016

The test results in this report pertain only to the item tested.

2.0 General Information

2.1 Product Description

Qolsys, Inc. supplied the following description of the EUT:

As described by the manufacturer, the EUT is a home security panel with cellular and WiFi/BT connection to the cloud, as well as specific radios for security sensors and automation.

This test report covers only the WiFi radio.

Information about the WiFi radio is presented below:

The EUT supports a wide range of data rates in the 2.4GHz band:

- IEEE 802.11b
- IEEE 802.11g
- IEEE 802.11n 20/40 MHz

Applicant	Qolsys, Inc.
Model Number	QS9201-1230-840
FCC Identifier	2AAJXQS-IQPANEL2
IC Identifier	11205A-QSIQPANEL2
Modulation Technique	DSSS (BPSK, QPSK, CCK), OFDM (BPSK, QPSK, 16QAM, 64QAM)
Rated RF Output	802.11b: 18.92 dBm 802.11g: 17.79 dBm 802.11n 20MHz : 17.84 dBm 802.11n 40MHz: 12.12 dBm
Frequency Range	2412 – 2462 MHz, 802.11b/g/n 20MHz 2422 – 2452 MHz, 802.11n 40 MHz
Type of modulation	BPSK, QPSK, 16QAM, 64QAM
Number of Channel(s)	11 for 802.11b/g/n, 20MHz channels 7 for 802.11n, 40MHz channels
Antenna(s) & Gain	Internal Antenna, 0.5dBi peak gain
Applicant Name & Address	Qolsys, Inc. 1900 The Alameda #420 San Jose, CA 95126 USA

2.2 Related Submittal(s) Grants

None.

2.3 Test Methodology

Antenna conducted measurements were performed according to the FCC documents “Guidance for Performing Compliance Measurement on Digital Transmission Systems (DTS) Operating under §15.247” (KDB 558074), and RSS-247, RSS-GEN, and

Radiated emissions and AC mains conducted emissions measurements were performed according to the procedures in ANSI C63.10. Radiated tests were performed at an antenna to EUT distance of 3 meters, unless stated otherwise in the "Data Sheet" of this report.

2.4 Test Facility

The test site used to collect the radiated data is site 1 (10-m semi-anechoic chamber). This test facility and site measurement data have been fully placed on file with the FCC, IC and A2LA accredited.

2.5 Measurement Uncertainty

Compliance with the limits was based on the results of the measurements and doesn't take into account the measurement uncertainty.

Estimated Measurement Uncertainty

Measurement	Expanded Uncertainty (k=2)		
	0.15 MHz – 1 GHz	1 GHz – 6 GHz	> 6 GHz
RF Power and Power Density – antenna conducted	1.1 dB	1.5 dB	–
Unwanted emissions - antenna conducted	1.2 dB	1.7 dB	2.0 dB
Bandwidth – antenna conducted	50 Hz	100 Hz	–
Radiated emissions	4.2 dB	5.4 dB	
AC mains conducted emissions	2.4 dB	-	-

3.0 System Test Configuration

3.1 Support Equipment and description

Description	Manufacturer	Model No./ Part No.
Power Adapter	Sure Power	SW-050200A
Laptop	Dell	Inspiron 14

3.2 Block Diagram of Test Setup

Antenna was removed and co-axial connector with a cable was installed for Conducted Measurements.
500hm Load was used for Radiated Measurements.

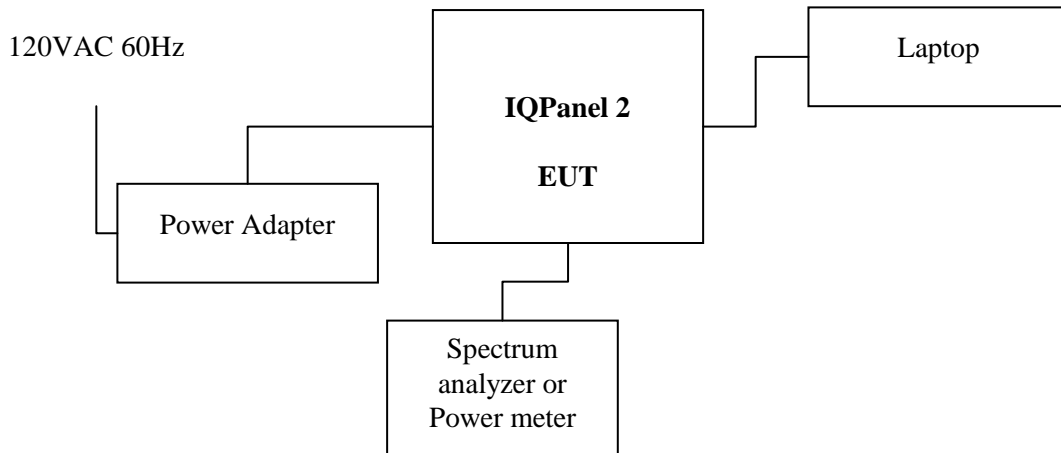

S = Shielded	F = With Ferrite
U = Unshielded	M = Meter

3.3 Justification

Preliminary testing was performed for all modulation/data rate modes. The worse-case data rate with highest power and widest spectrum were selected for final measurements:

CCK 1 Mbps – for 802.11b
OFDM 6 Mbps – for 802.11g
OFDM MCS0 – for 802.11n 20/40 MHz

Unless otherwise stated in this report, measurements made for Power Density, Bandwidth, Conducted Spurious, Radiated Spurious (Cabinet Radiation) were made with the worst case power setting (mid channel power).

The difference between the models: IQPANEL2, IQPANEL2-ZW, IQPANEL2-ZB, IQPANEL2-ZZ are as below:

Model: IQPANEL2: Home Security Panel consists of WiFi/BT/LTE radios and SRF receiver.

Model: IQPANEL2-ZW: model: IQPANEL2 with approved module having FCC ID: 2AAJXQS-ZWAVE and IC: 11205A-QSZWAVE.

Model: IQPANEL2-ZB: model: IQPANEL2 with approved module having FCC ID: 2AAJXQS-IS and IC: 11205A-QSIS.

Model: IQPANEL2-ZZ: model: IQPANEL2 with approved modules having FCC ID: 2AAJXQS-IS, FCC ID: 2AAJXQS-ZWAVE, IC: 11205A-QSIS and IC: 11205A-QSZWAVE.

All tests were performed on the fully populated Model: IQPANEL2-ZZ. The results in this report are valid for the other models IQPANEL2, IQPANEL2-ZW and IQPANEL2-ZB as well.

3.4 Mode of Operation During Test

During transmitter testing, the transmitter was setup to transmit continuously using the RF power setting below. Their corresponding output power in dBm can be found in section 4.2 of this report.

Frequency (MHz)	Channel	802.11b	802.11g	802.11n 20MHz	802.11n 40MHz
2412	1	18	15	14	-
2417	2	-	18	18	-
2422	3	-	-	-	13
2437	6	18	18	18	13
2447	8	-	-	-	11
2452	9	-	-	-	9
2457	10	-	17	16	-
2462	11	18	14	13	-

3.5 Modifications Required for Compliance

Intertek installed no modifications during compliance testing in order to bring the product into compliance.

3.6 Additions, Deviations and Exclusions from Standards

No additions, deviations or exclusions from the standard were made.

4.0 Measurement Results

4.1 6dB DTS Bandwidth, 6dB RSS Bandwidth and 99% Occupied Bandwidth FCC Rule 15.247(a)(2)

4.1.1 Requirement

The minimum 6-dB bandwidth shall be at least 500 kHz

4.1.2 Procedure

The Procedure described in the FCC Publication 558074 was used.

The antenna port of the EUT was connected to the input of a spectrum analyzer (SA). For each RF output channel investigated, the spectrum analyzer center frequency was set to the channel carrier. A PEAK output reading was taken, a DISPLAY line was drawn 6 dB lower than PEAK level. The 6-dB bandwidth was determined from where the channel output spectrum intersected the display line.

The occupied bandwidth was measured using the built-in spectrum analyzer function for 99% power bandwidth measurement.

Test Date:	February 2-3 & 8, 2016
------------	------------------------

4.1.3 Test Result

Frequency MHz	Ch.	Frequency MHz	6 dB FCC Bandwidth, MHz	Plot #	99% Bandwidth, MHz	Plot #	6 dB RSS Bandwidth, MHz	Plot #
802.11b	1	2412	10.08	1.1	14.57	1.13	10.11	1.13
	6	2437	10.02	1.2	13.93	1.14	10.00	1.14
	11	2462	9.66	1.3	13.44	1.15	10.00	1.15
802.11g	1	2412	16.34	1.4	17.97	1.16	16.51	1.16
	6	2437	16.40	1.5	17.75	1.17	16.54	1.17
	11	2462	16.37	1.6	17.17	1.18	16.44	1.18
802.11n 20MHz	1	2412	17.62	1.7	18.71	1.16	17.76	1.16
	6	2437	17.68	1.8	18.49	1.17	17.78	1.17
	11	2462	17.55	1.9	18.83	1.18	17.65	1.18
802.11n 40MHz	3	2422	35.68	1.10	36.22	1.19	35.77	1.19
	6	2437	35.79	1.11	36.36	1.20	36.06	1.20
	9	2452	35.87	1.12	36.20	1.21	35.29	1.21

Plot 1.1 – 6dB Bandwidth (FCC)

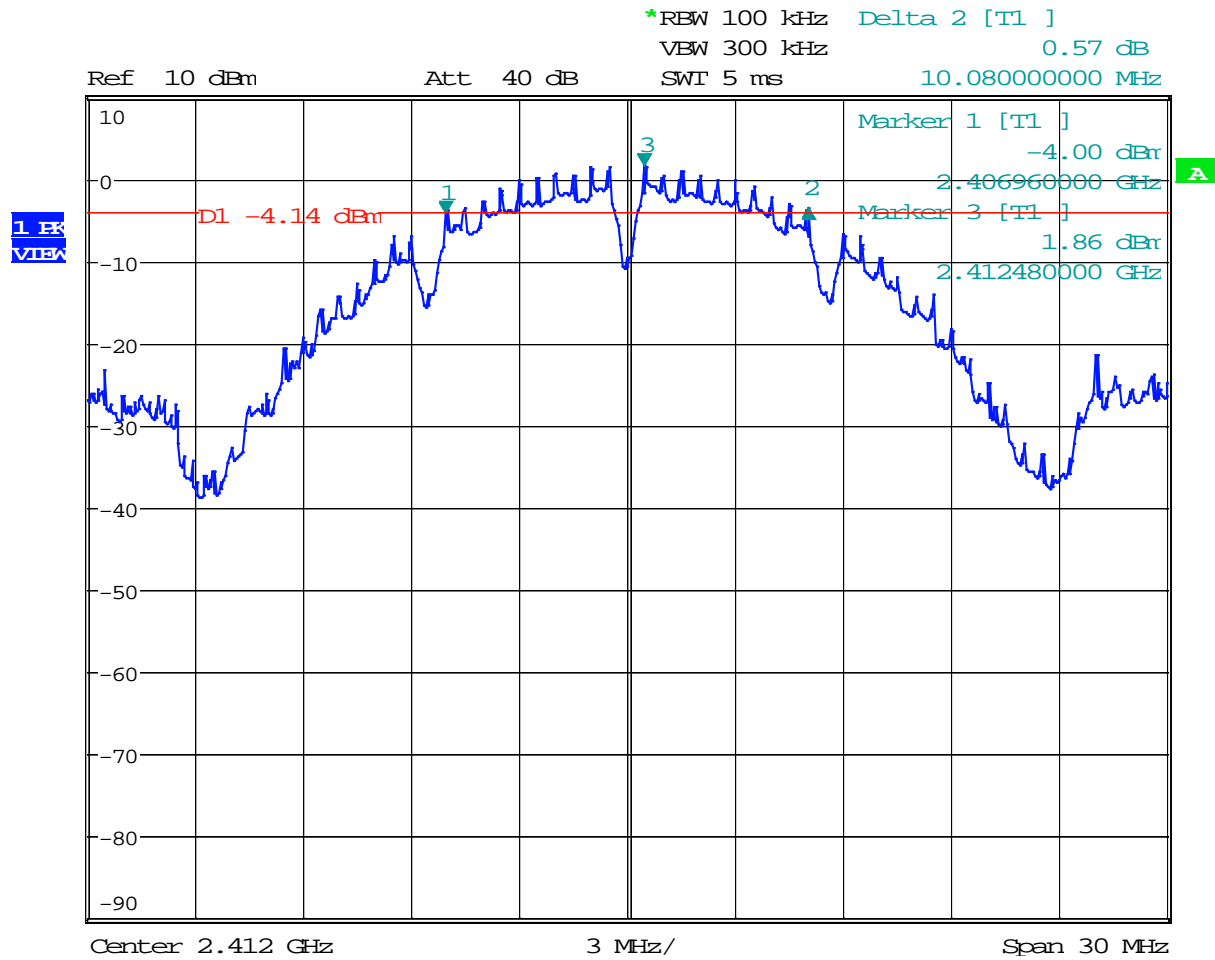

Date: 2.FEB.2016 15:25:15

Plot 1.2 – 6dB Bandwidth (FCC)

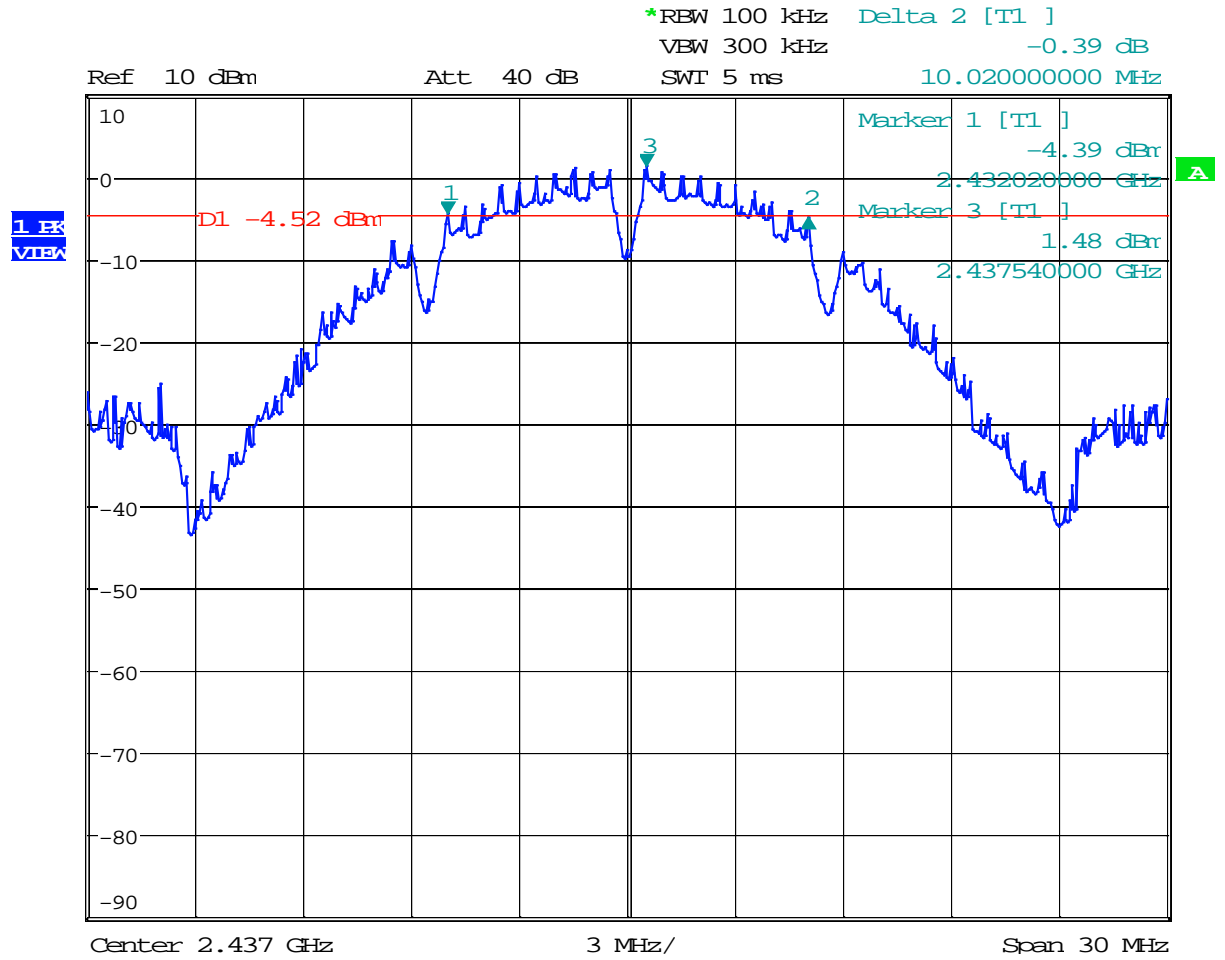

Date: 2.FEB.2016 15:28:04

Plot 1 3 - 6dB Bandwidth (FCC)

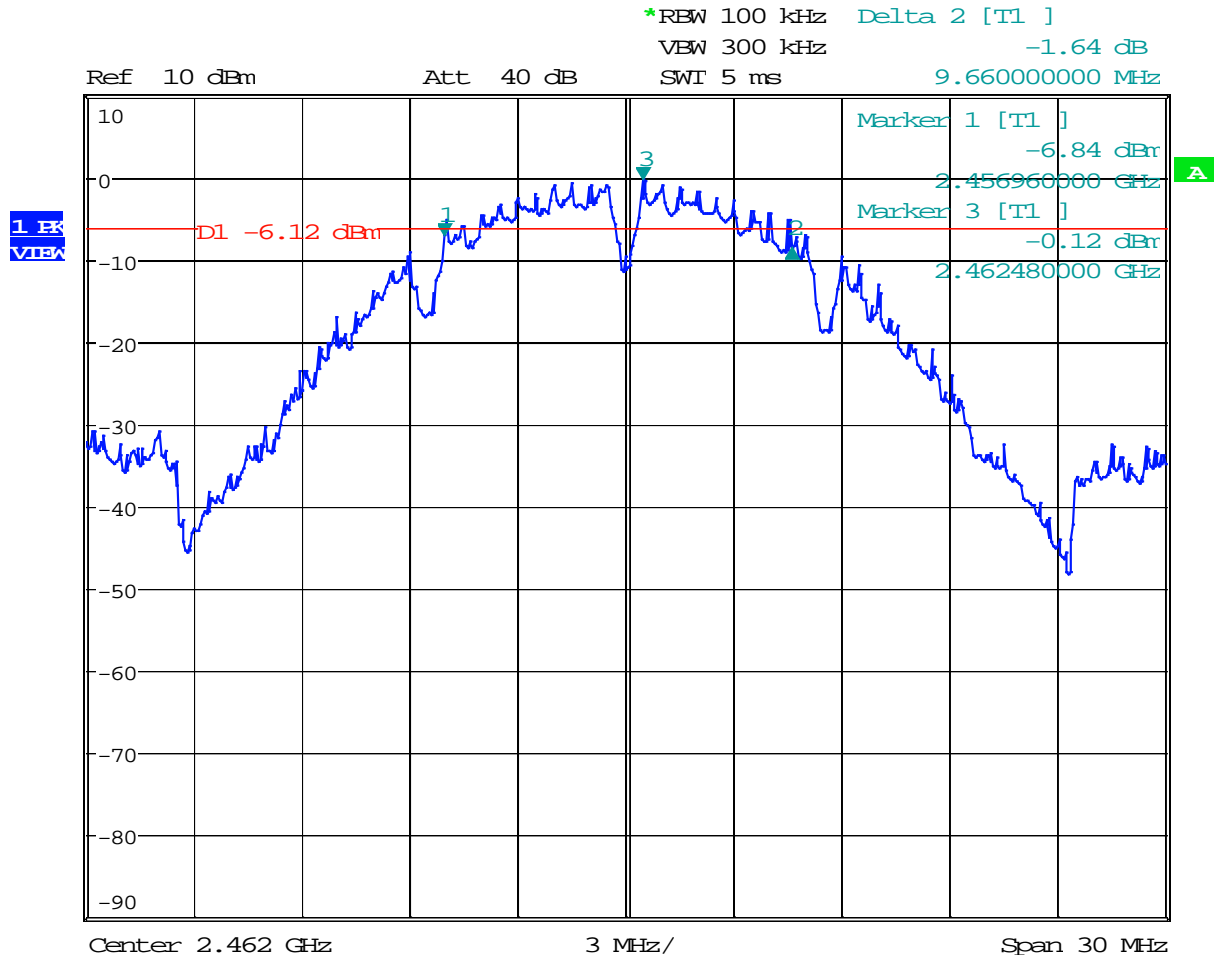

Date: 2.FEB.2016 15:31:51

Plot 1.4 - 6dB Bandwidth (FCC)

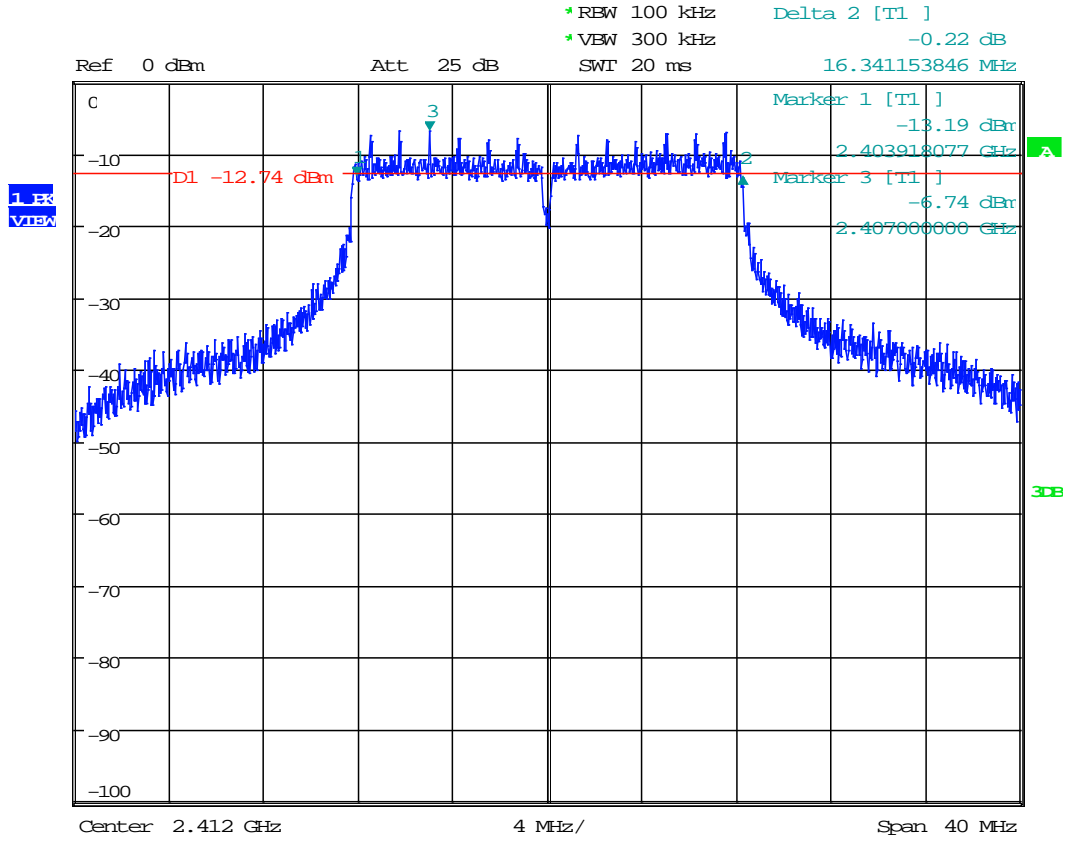

Date: 3.FEB.2016 03:59:52

Plot 1.5 – 6dB Bandwidth (FCC)

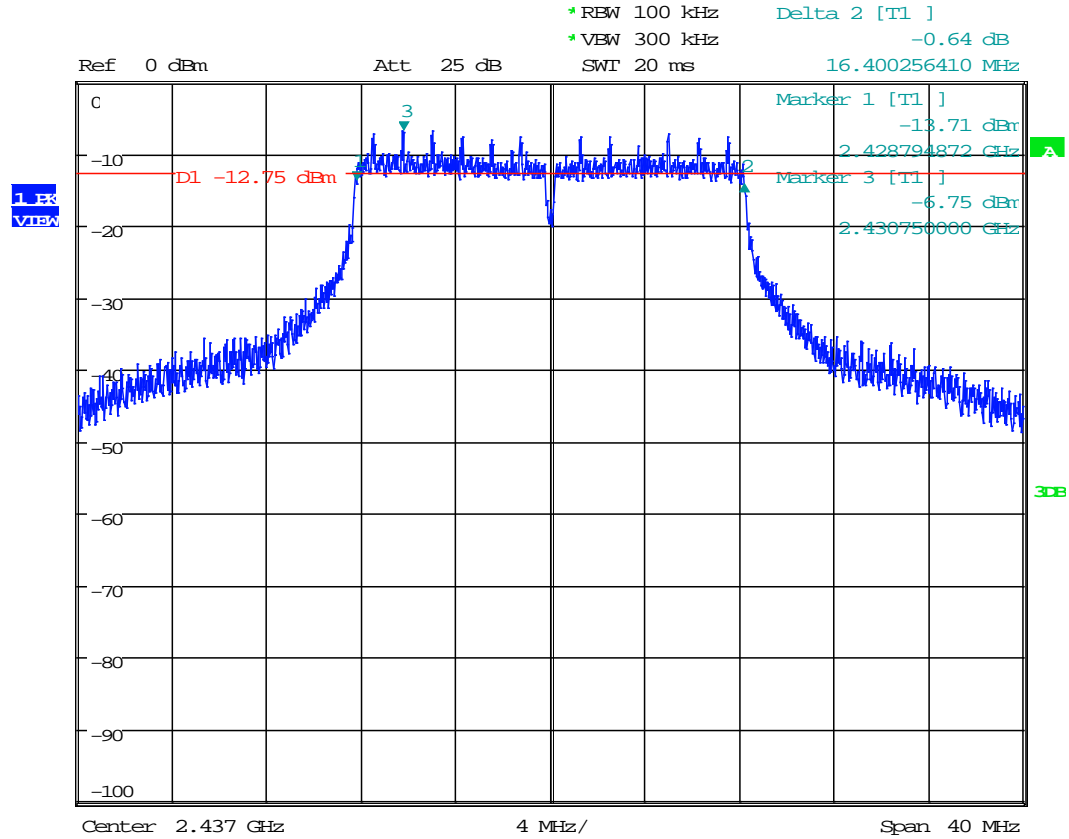

Date: 3.FEB.2016 04:02:37

Plot 1.6 – 6dB Bandwidth (FCC)

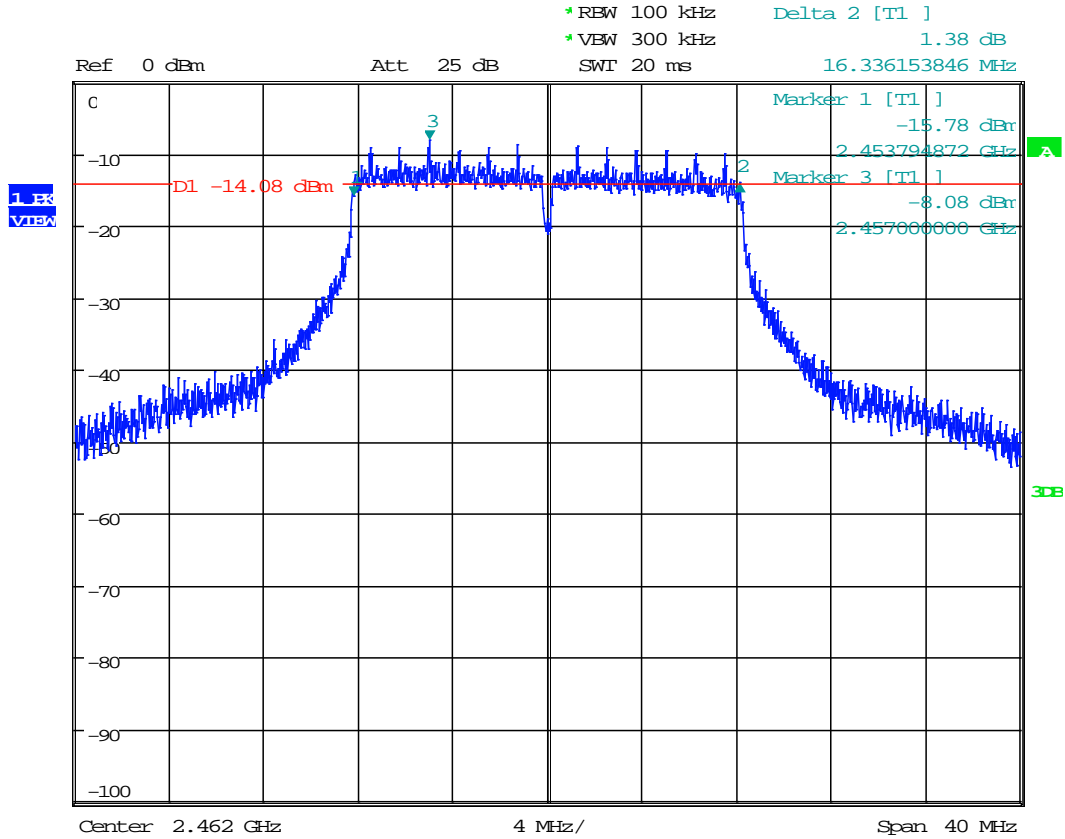

Date: 3.FEB.2016 04:07:26

Plot 1.7 – 6dB Bandwidth (FCC)

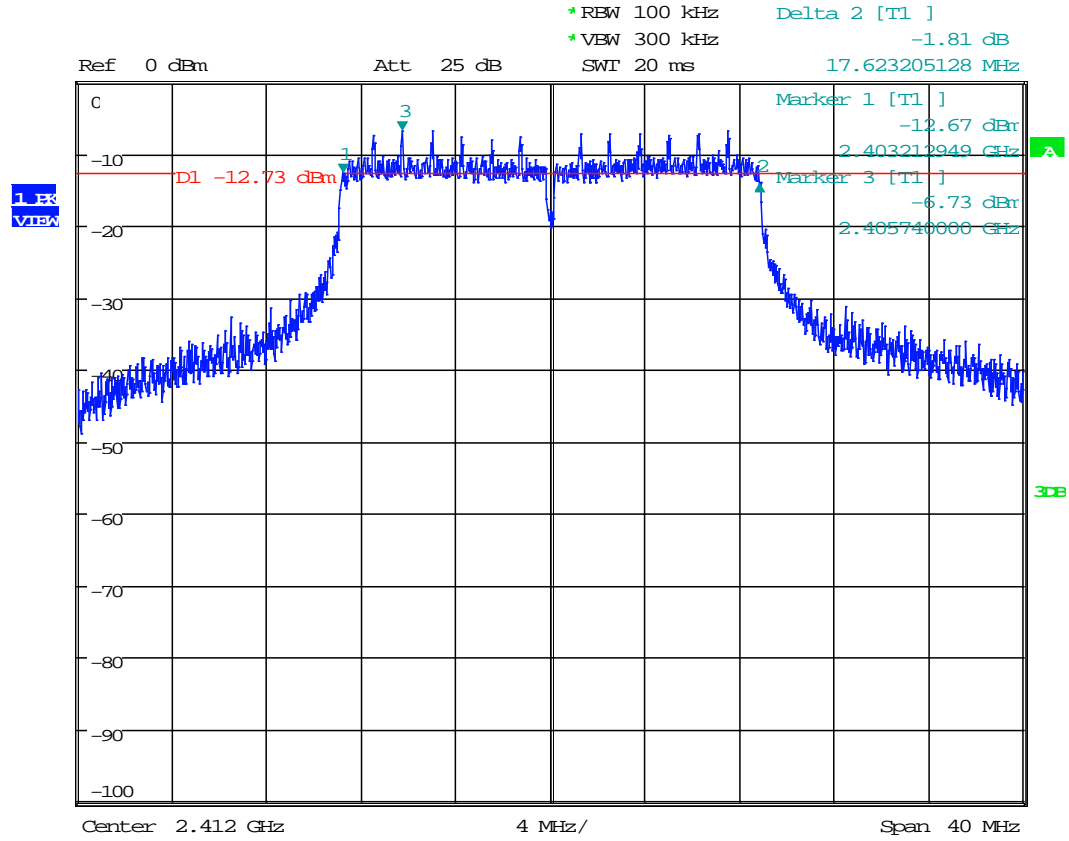

Date: 3.FEB.2016 04:01:18

Plot 1.8 – 6dB Bandwidth (FCC)

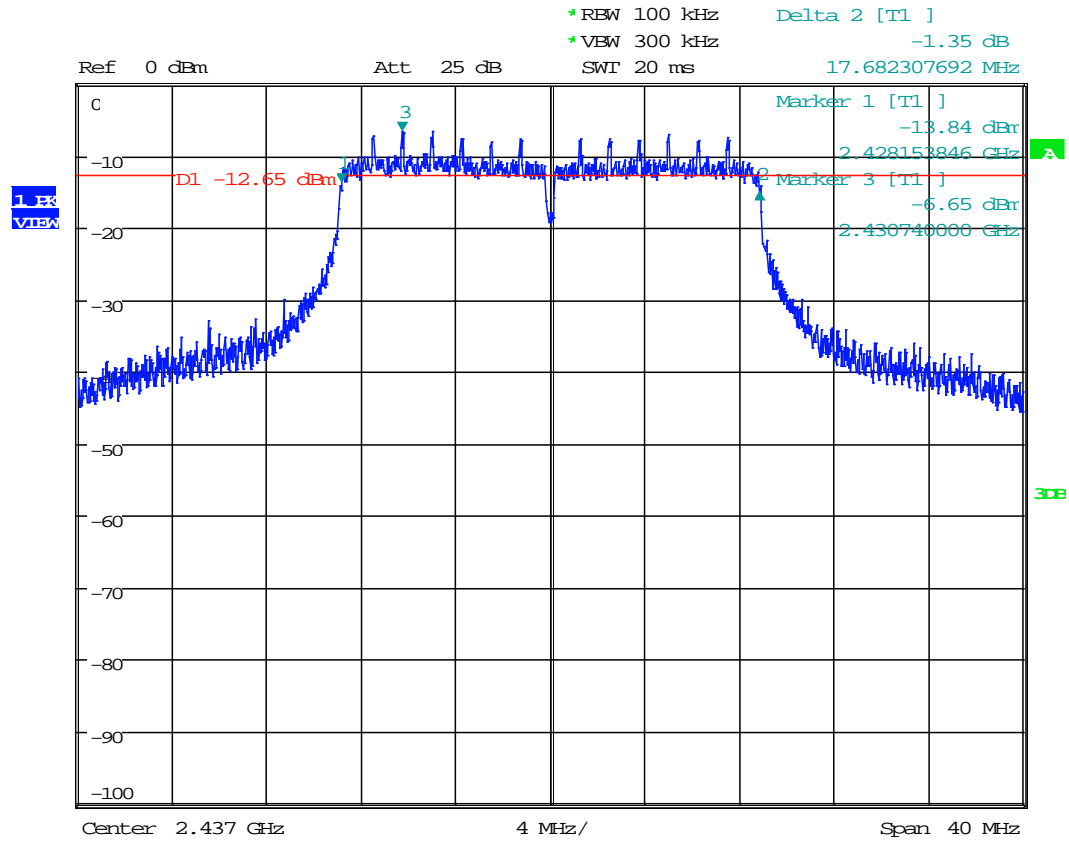

Date: 3.FEB.2016 04:04:48



Plot 1.9 – 6dB Bandwidth (FCC)

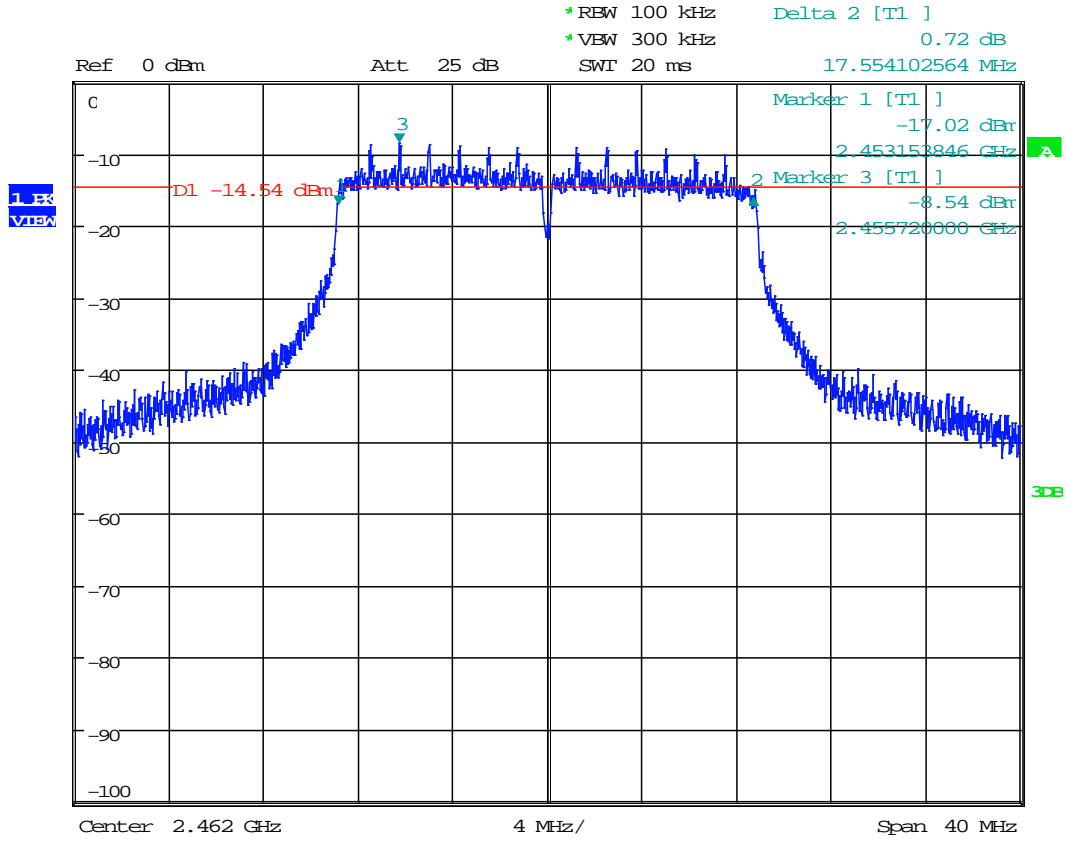

Date: 3.FEB.2016 04:08:52

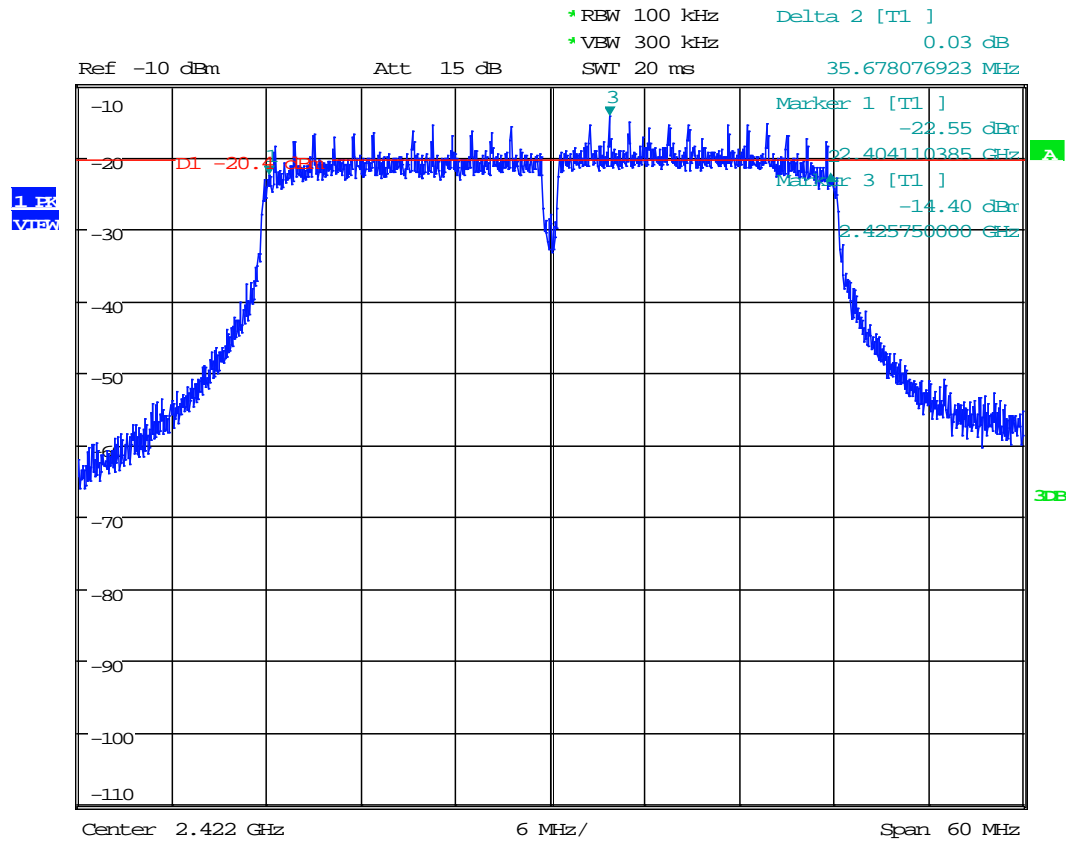

Date: 3.FEB.2016 03:57:33

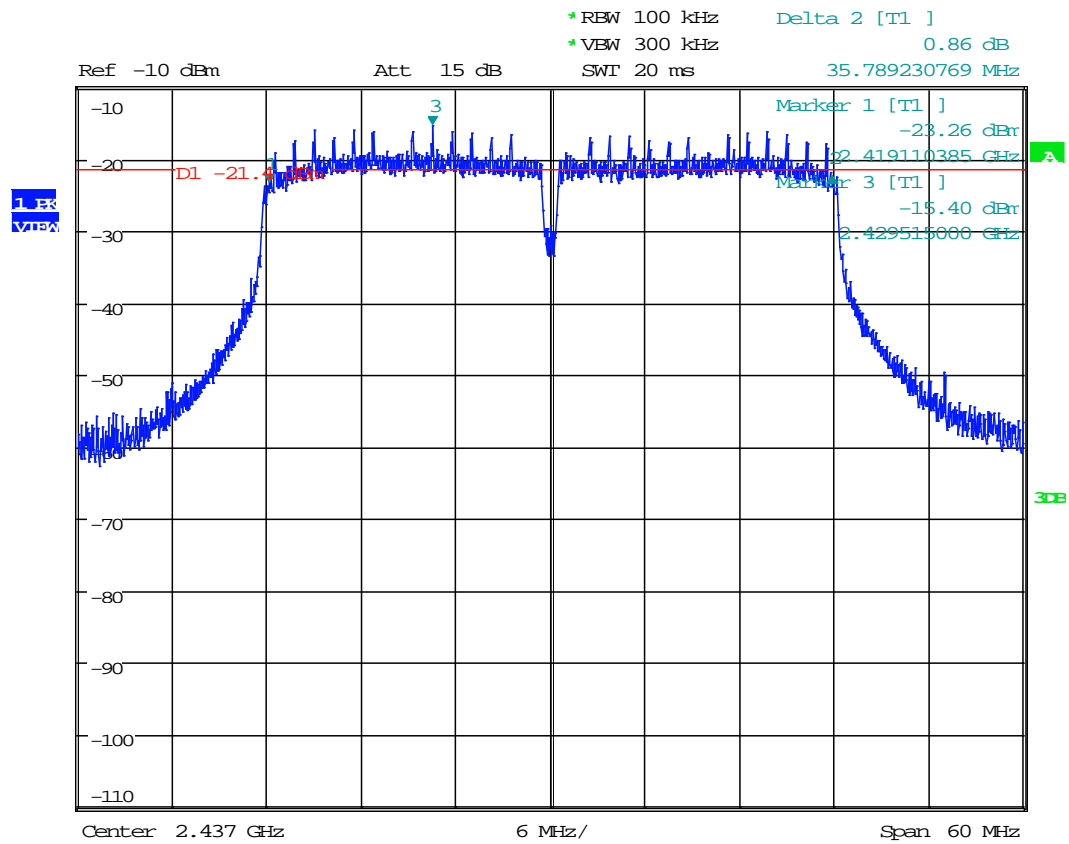

Date: 3.FEB.2016 03:55:42

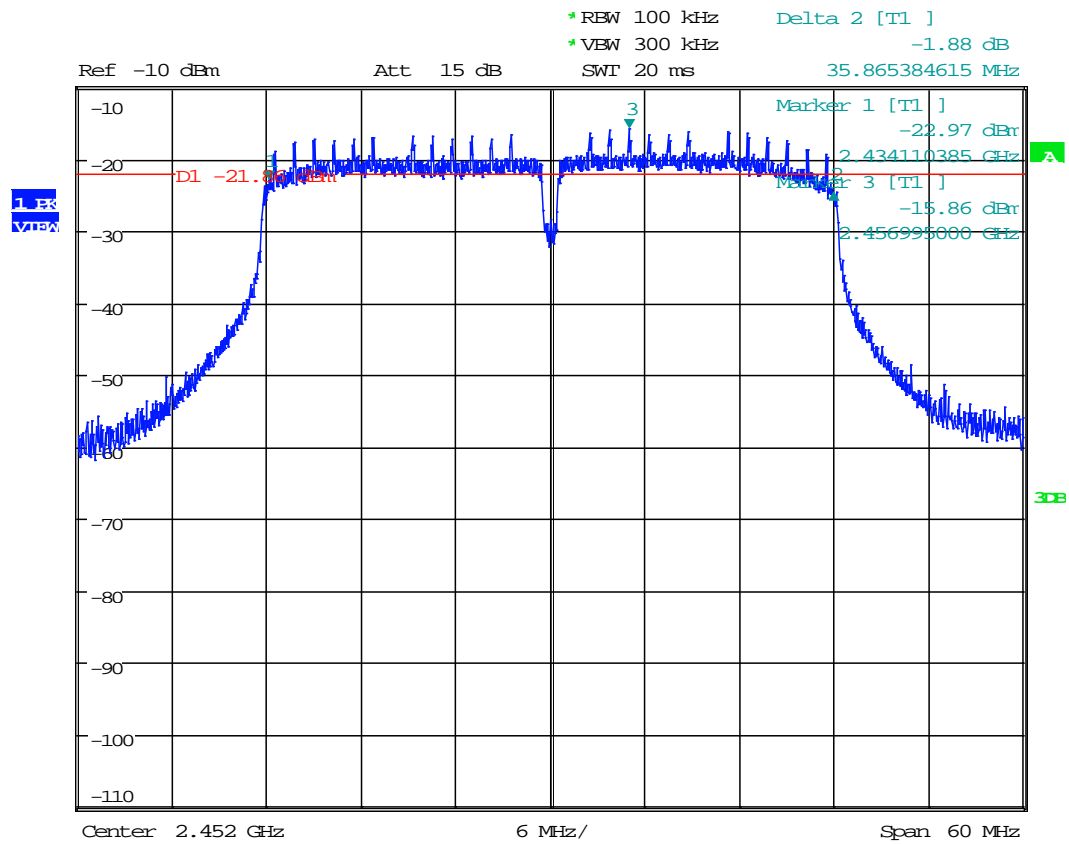

Date: 3.FEB.2016 03:50:39

Plot 1.10 – 99% Bandwidth

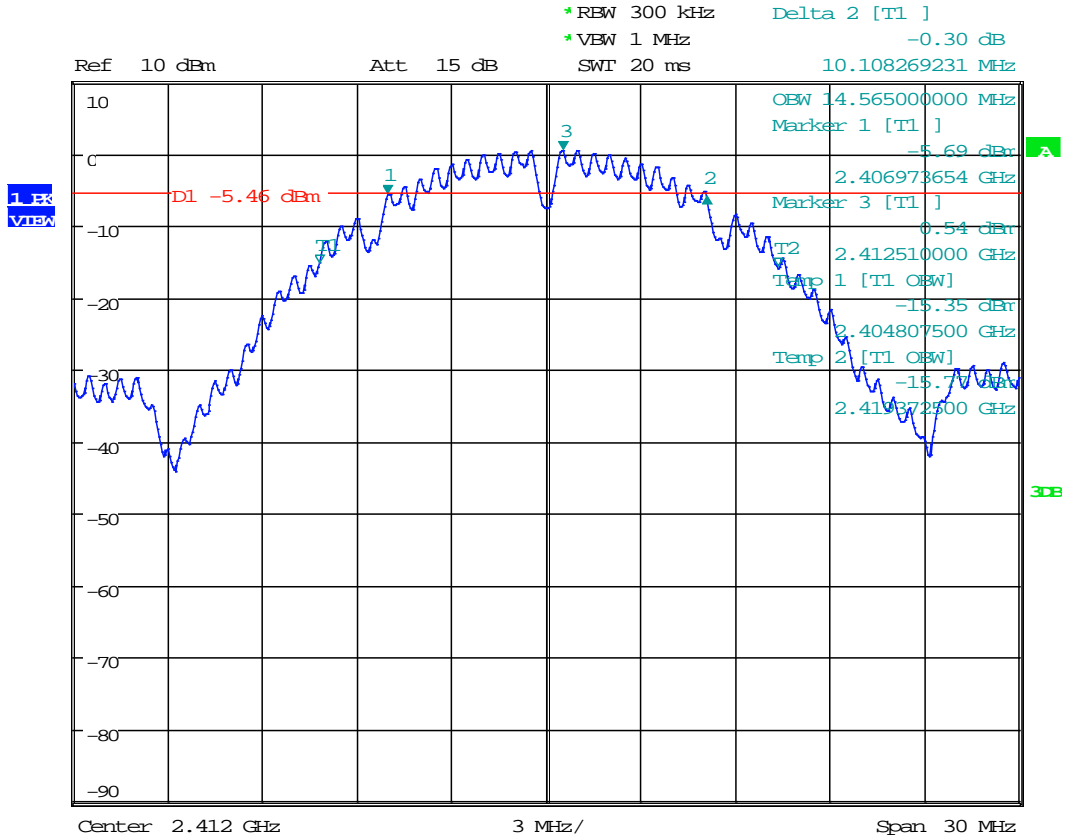

Date: 8.FEB.2016 04:13:57

Plot 1.11 – 99% Bandwidth

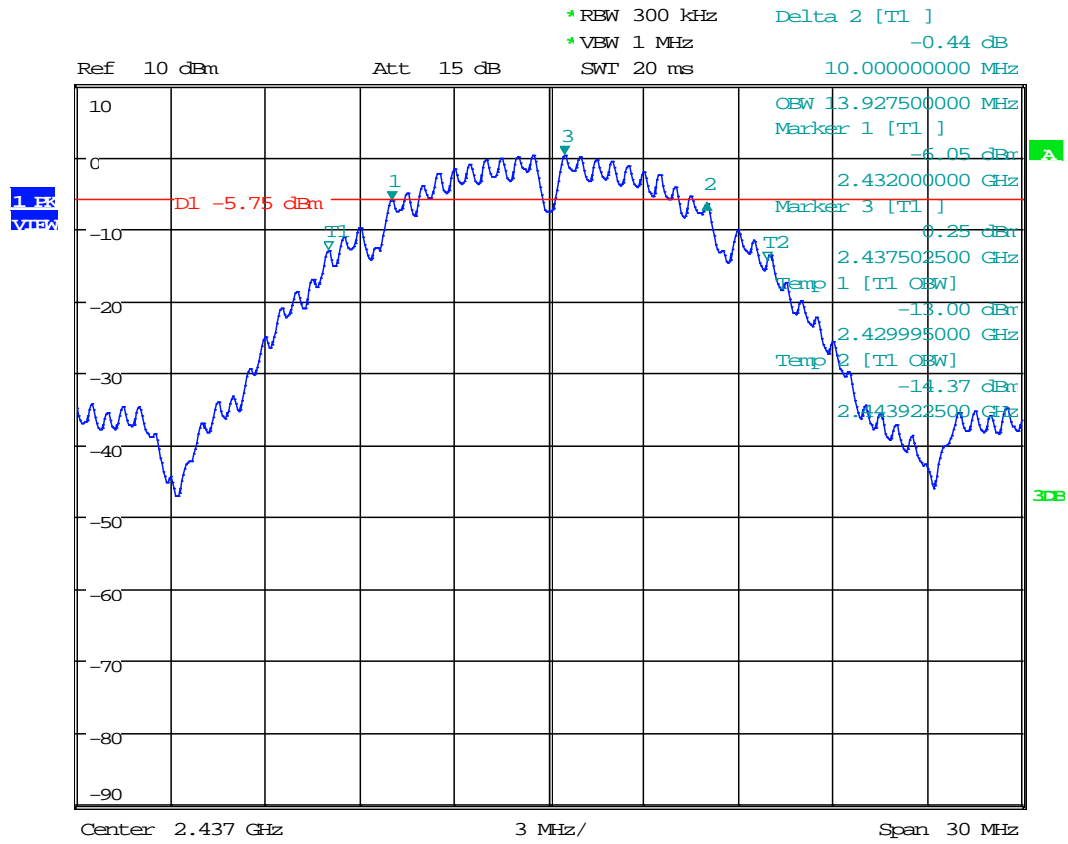

Date: 8.FEB.2016 04:17:25

Plot 1.12 – 99% Bandwidth

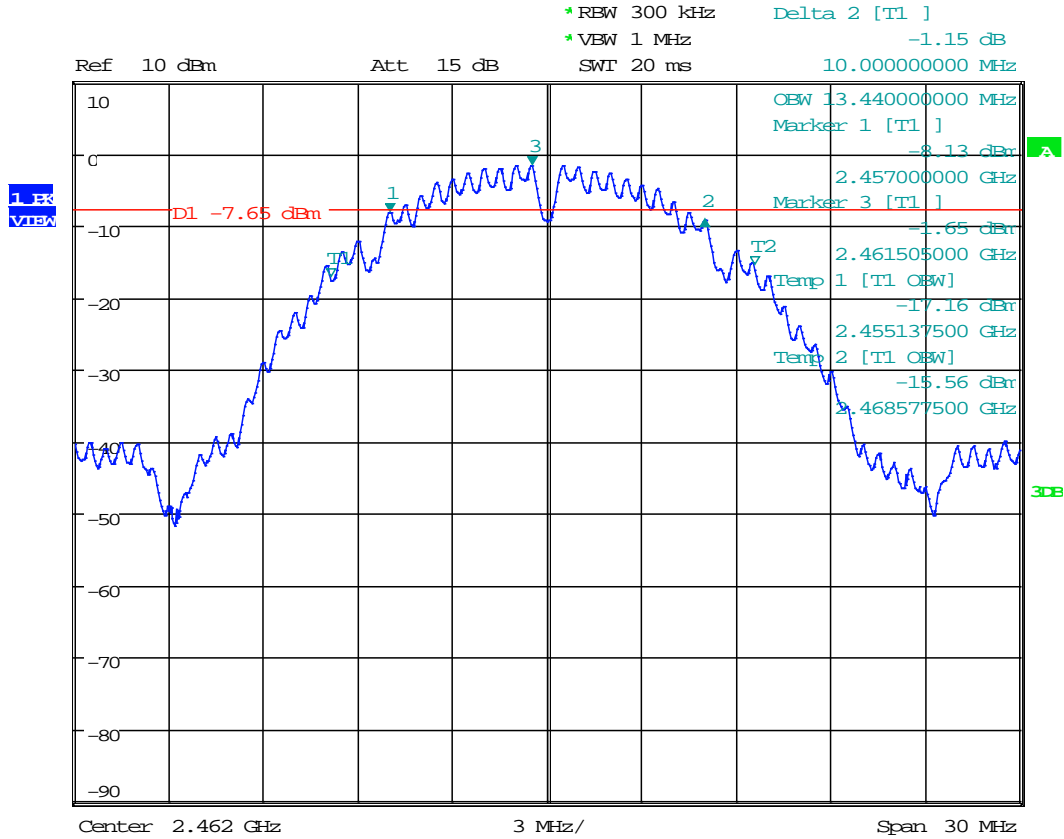

Date: 8.FEB.2016 04:18:49

Plot 1.13 – 99% Bandwidth

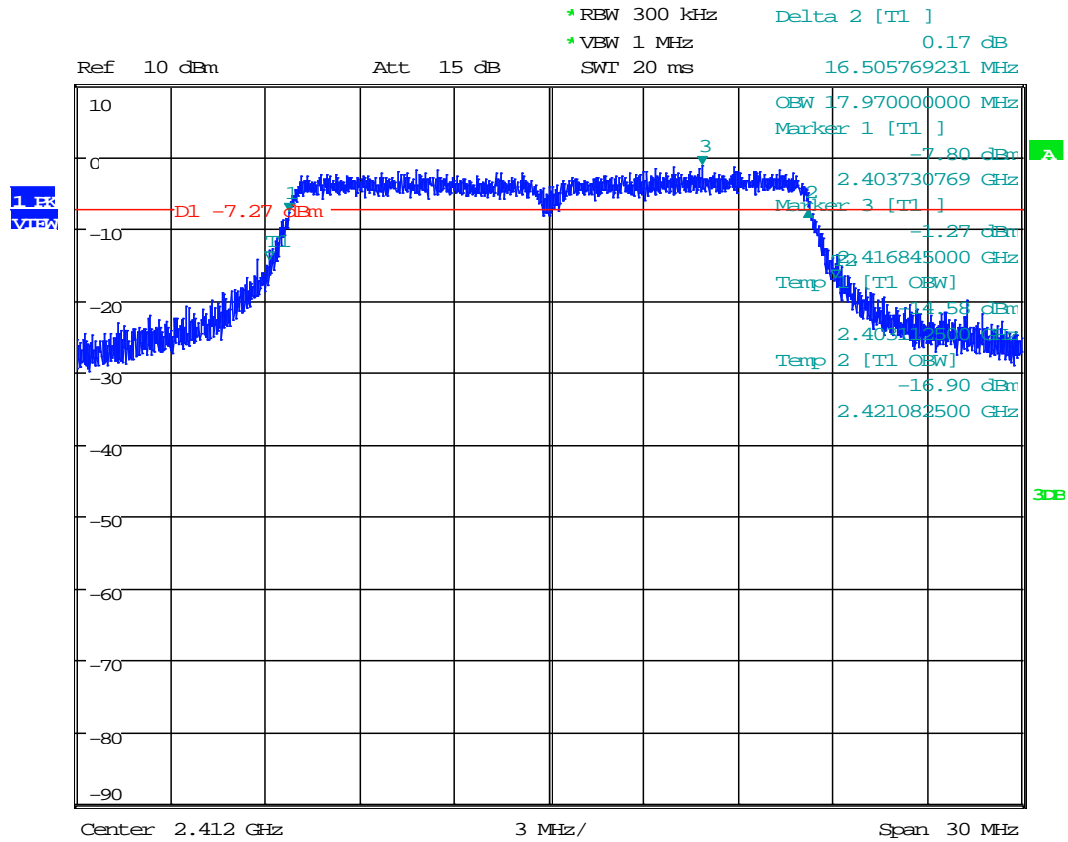

Date: 8.FEB.2016 04:25:25

Plot 1.14 – 99% Bandwidth

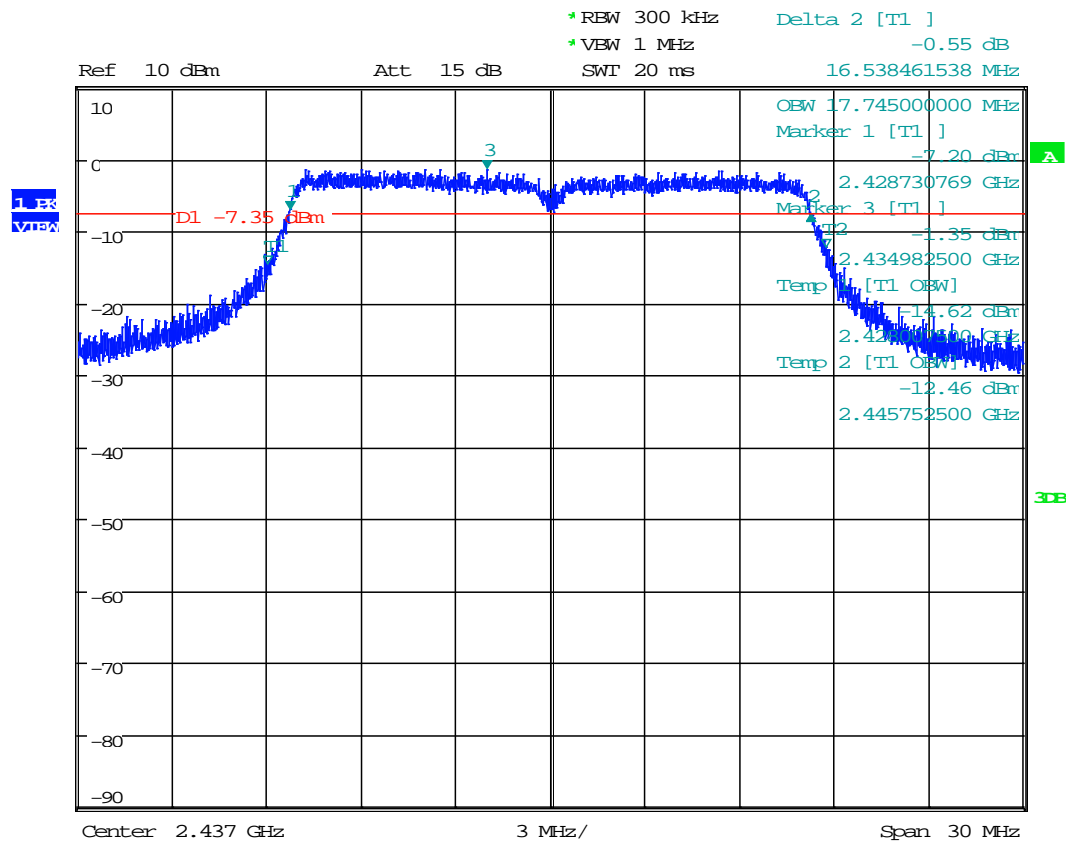

Date: 8.FEB.2016 04:22:37

Plot 1.15 – 99% Bandwidth

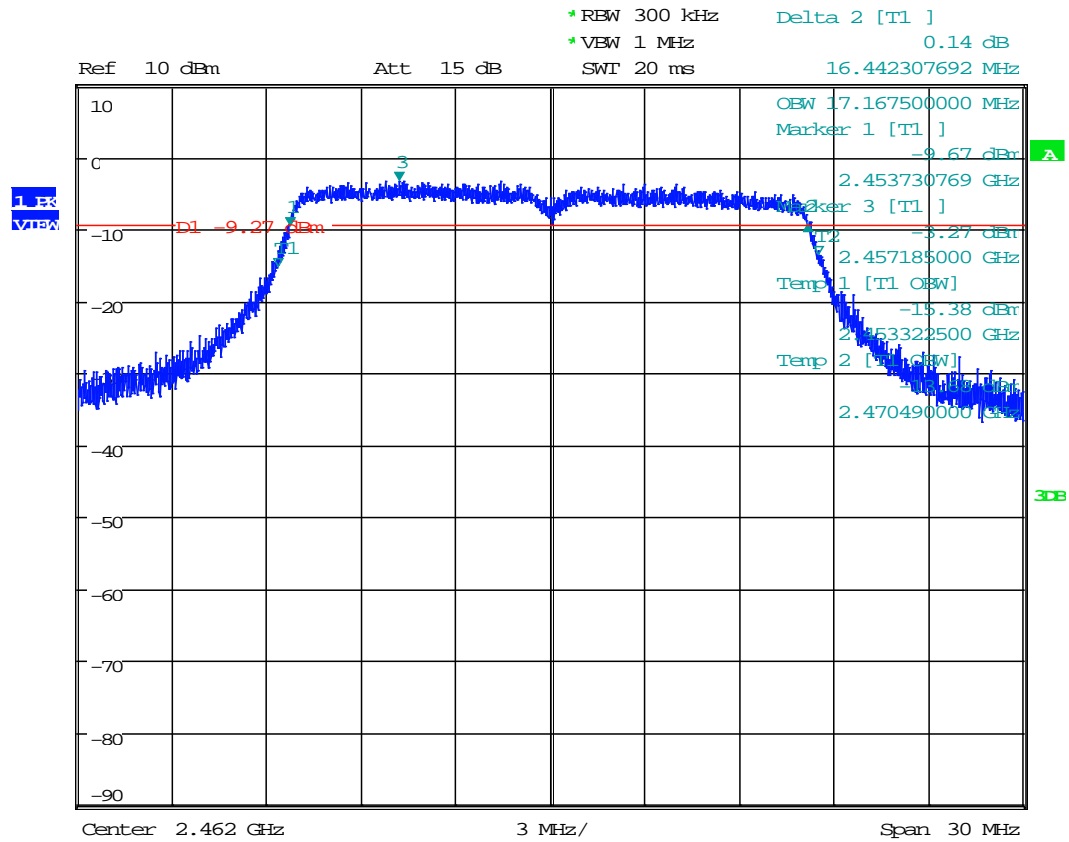

Date: 8.FEB.2016 04:20:39

Plot 1.16 – 99% Bandwidth

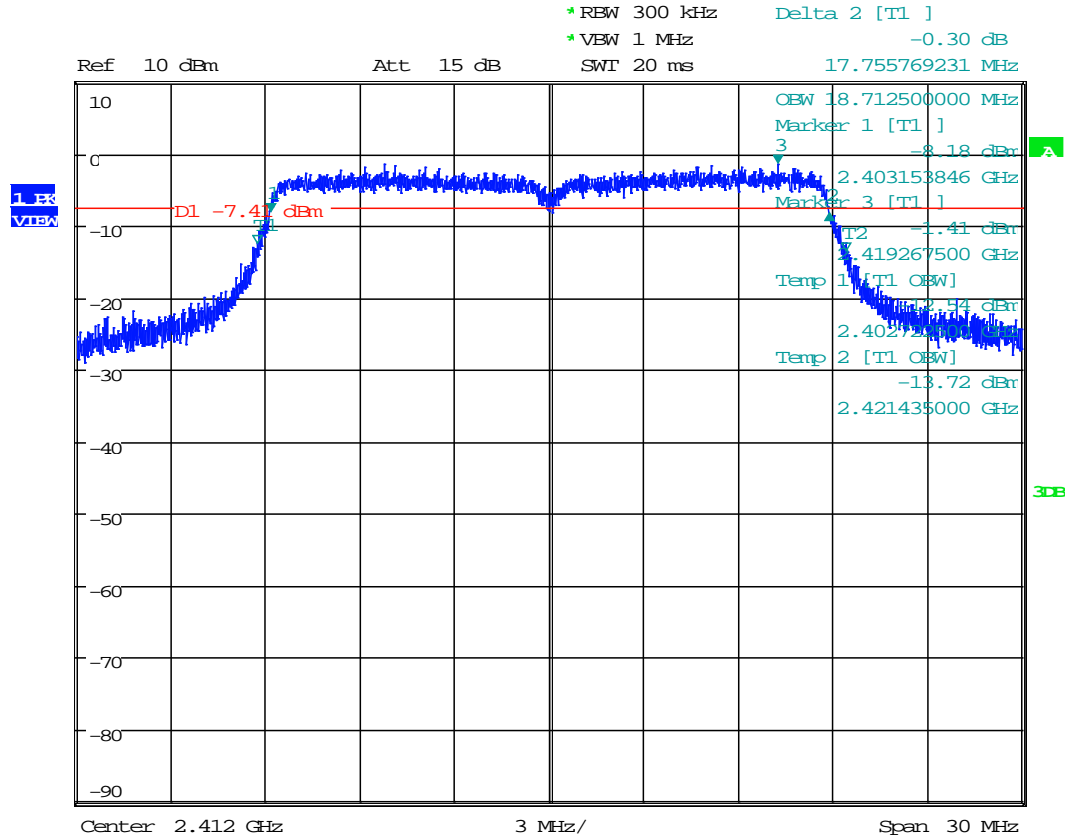

Date: 8.FEB.2016 04:26:27

Plot 1.17 - 99% Bandwidth

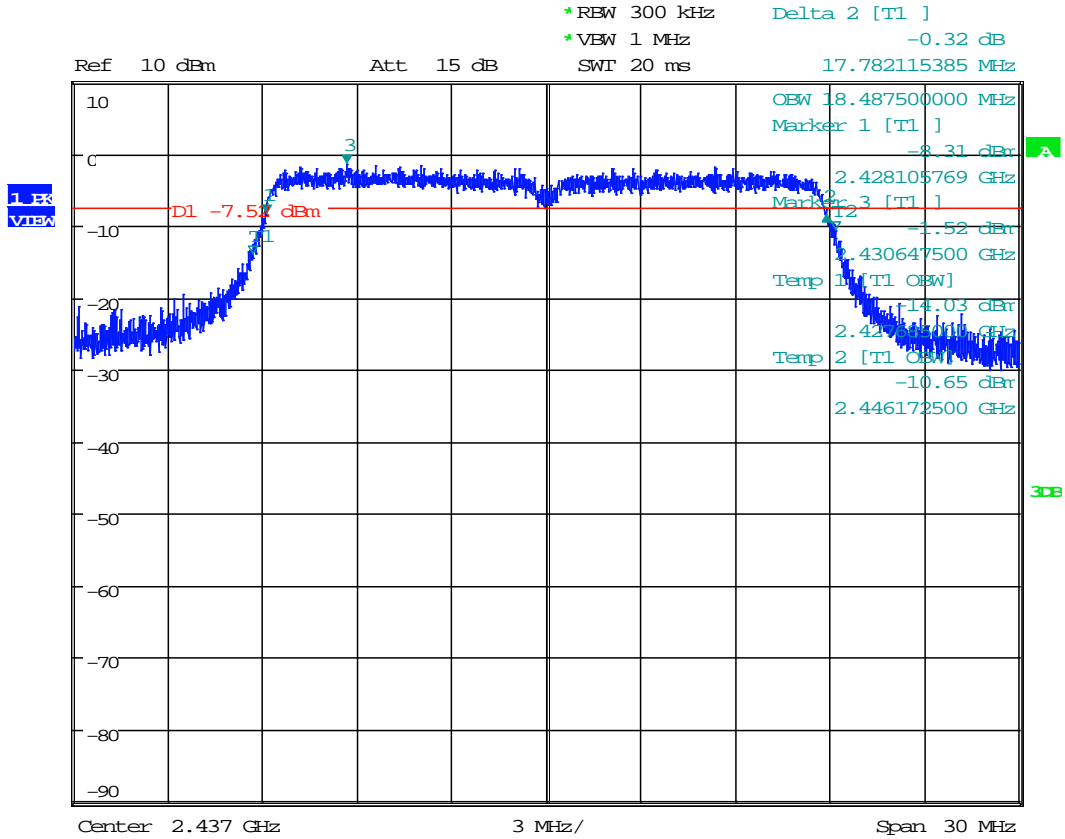

Date: 8.FEB.2016 04:28:09

Plot 1.18 – 99% Bandwidth

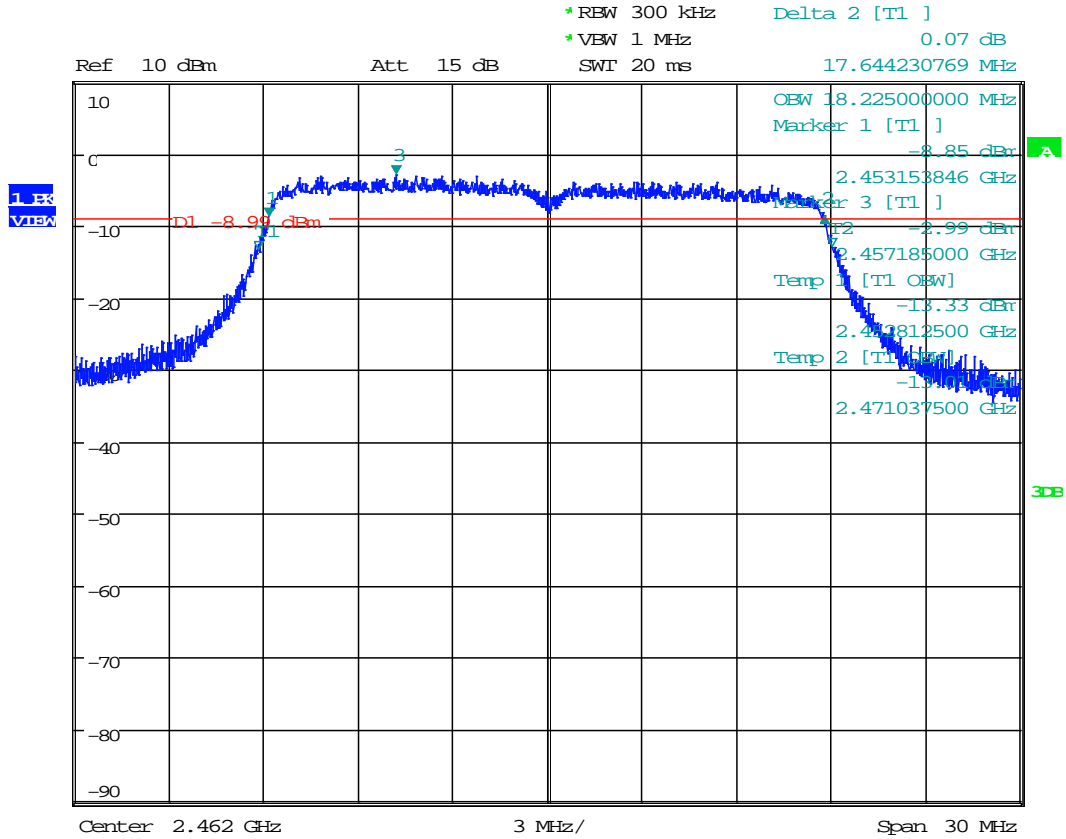

Date: 8.FEB.2016 04:31:57

Plot 1.19 – 99% Bandwidth

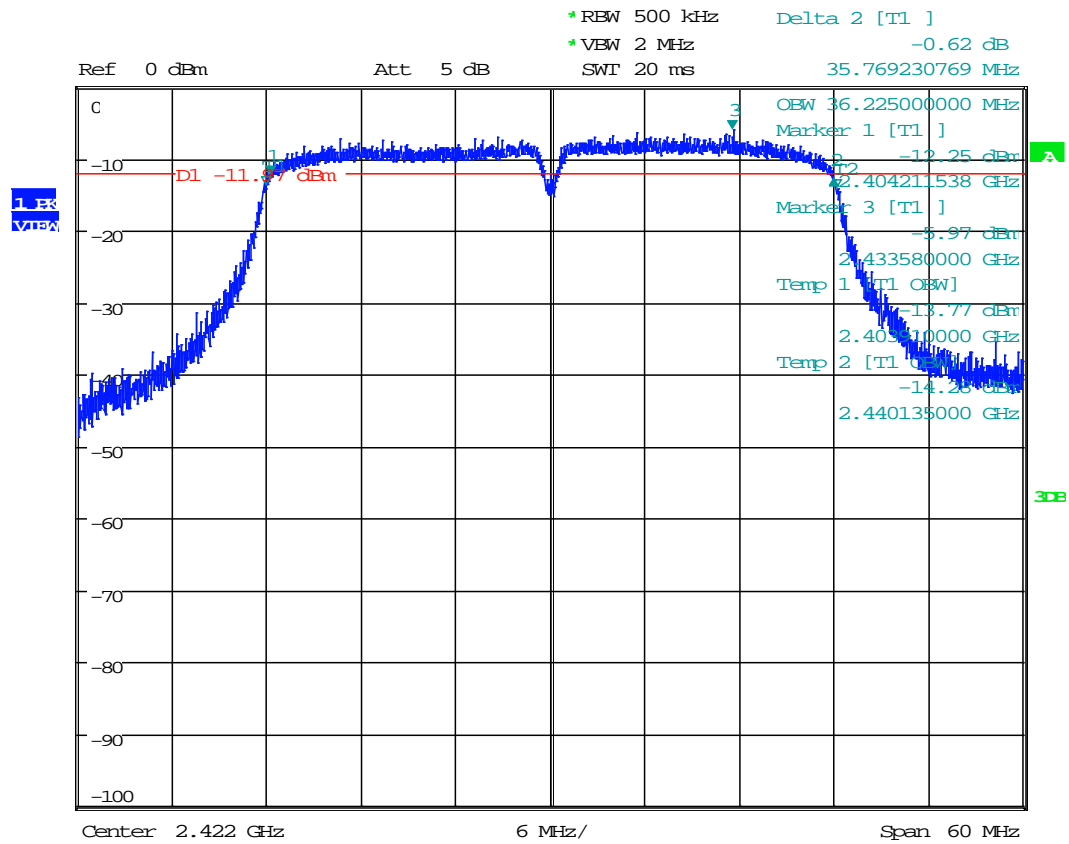

Date: 8.FEB.2016 04:38:19

Plot 1.20 – 99% Bandwidth

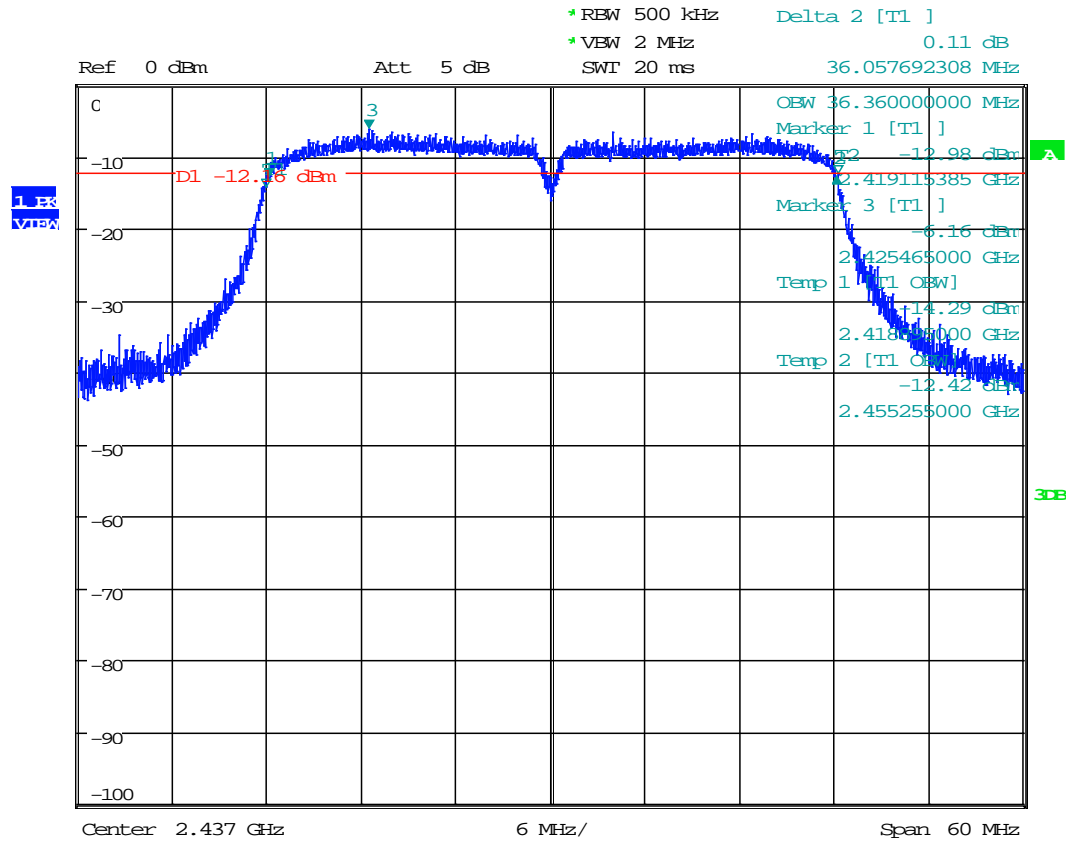

Date: 8.FEB.2016 04:40:04

Plot 1.21 – 99% Bandwidth

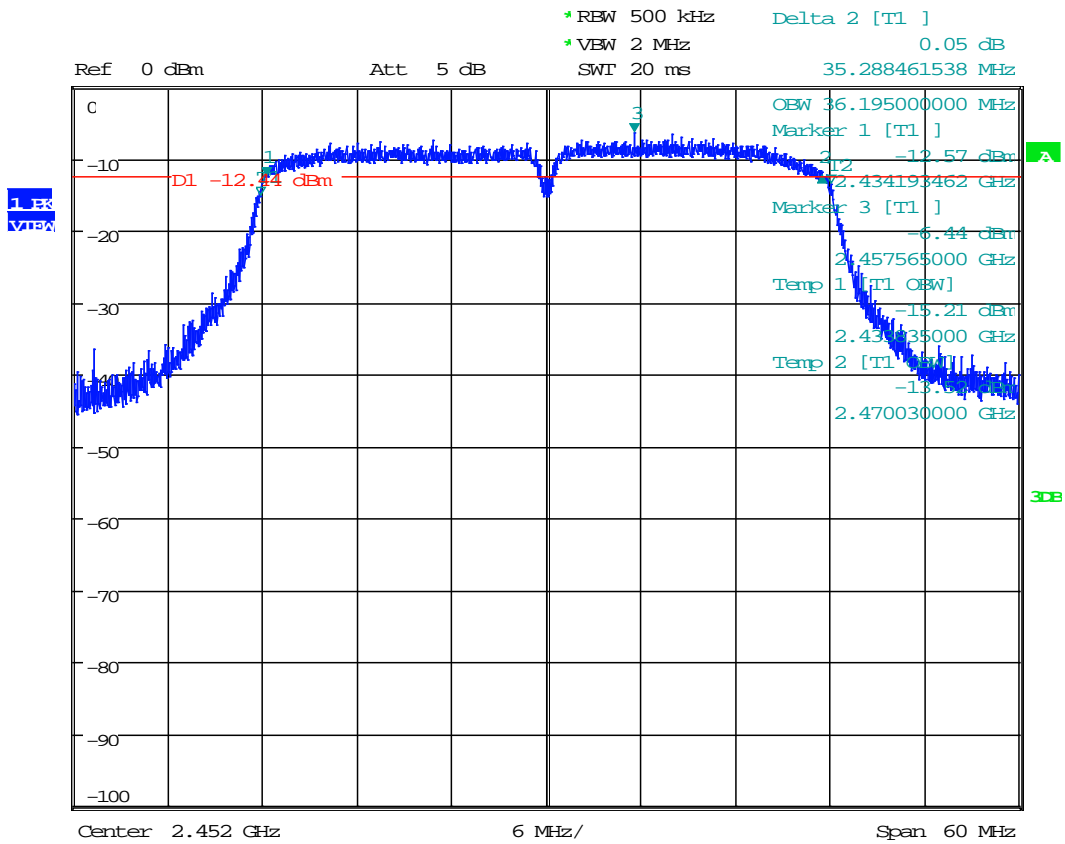

Date: 8.FEB.2016 04:43:58

4.2 Maximum Conducted Output Power at Antenna Terminals FCC Rule 15.247(b)(3)

4.2.1 Requirement

For antennas with gains of 6 dBi or less, maximum allowed transmitter output is 1 watt (+30 dBm). For antennas with gains greater than 6 dBi, transmitter output level must be decreased appropriately, by the amount in dB that the directional gain of the antenna exceeds 6 dBi.

4.2.2 Procedure

The antenna port of the EUT was connected to the input of a spectrum analyzer/power meter to measure the Maximum Conducted Transmitter Output Power.

The procedure described in FCC Publication 558074 D01 DTS Meas Guidance was used. Specifically, section 9.2.2.2 Method AVGSA-1.

1. Set the RBW = 1-5% of the OBW, not to exceed 1MHz.
2. Set the VBW $\geq 3 \times$ RBW
3. Set the span $\geq 1.5 \times$ OBW.
4. Detector = RMS.
5. Sweep time = auto couple.
6. Trace mode = power averaging (100 traces)
7. Number of points in sweep $\geq 2 \times$ span/RBW.
8. Use the instrument's band/channel power measurement function with the band limits set equal to the OBW band edges. If the instrument does not have a band power function, sum the spectrum levels at intervals equal to the RBW extending across the entire OBW of the spectrum.

Test Date:	February 8, 2016
------------	------------------

4.2.3 Test Result

Refer to the following plots for the test result:

Standard	Data Rate	Channel	Frequency MHz	Conducted Average Power dBm	Conducted Average Power mW	Plot #
802.11b	1 Mbps	1	2412	18.92	77.98	2.1
		6	2437	18.28	67.30	2.2
		11	2462	17.08	51.05	2.3
802.11g	6 Mbps	1	2412	14.87	30.69	2.4
		6	2437	17.79	60.12	2.5
		10	2457	15.28	33.73	2.6
		11	2462	11.73	14.89	2.7
802.11n 20MHz	0 MCS	1	2412	13.81	24.04	2.8
		2	2417	17.58	57.28	2.9
		6	2437	17.84	60.81	2.10
		10	2457	13.37	21.73	2.11
		11	2462	10.37	10.89	2.12
802.11n 40MHz	0 MCS	3	2422	12.12	16.29	2.13
		6	2437	11.64	14.59	2.14
		8	2447	9.77	9.48	2.15
		9	2452	7.17	5.21	2.16

Plot 2. 1

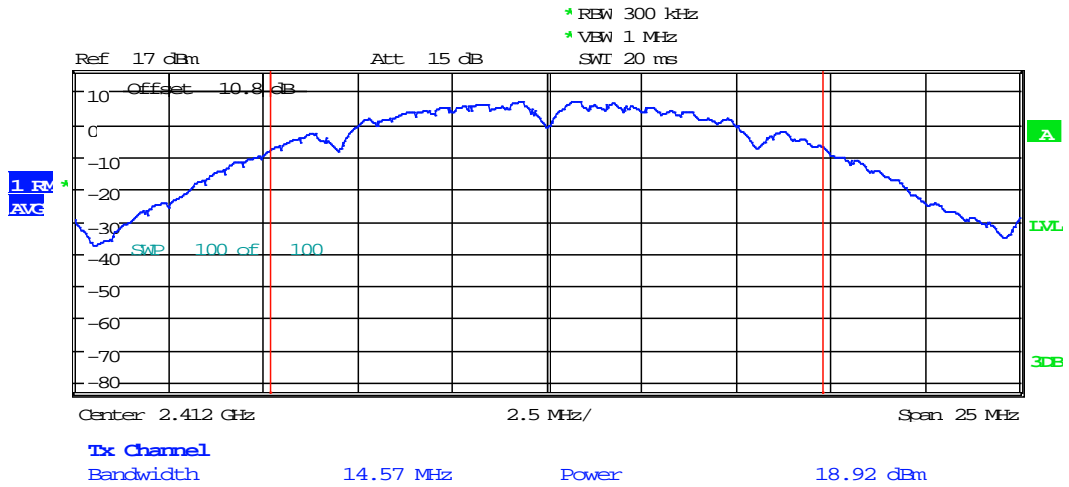

Plot 2. 2

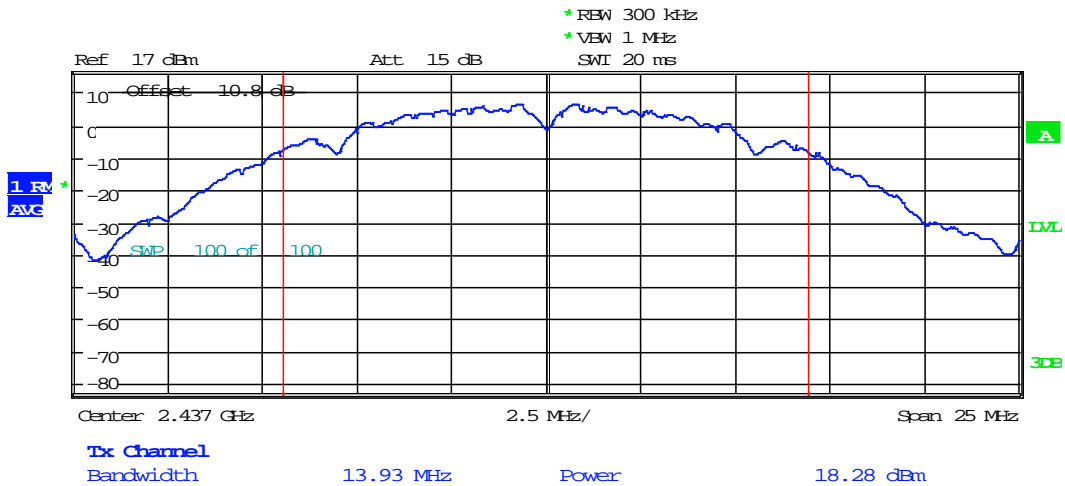

Plot 2.3

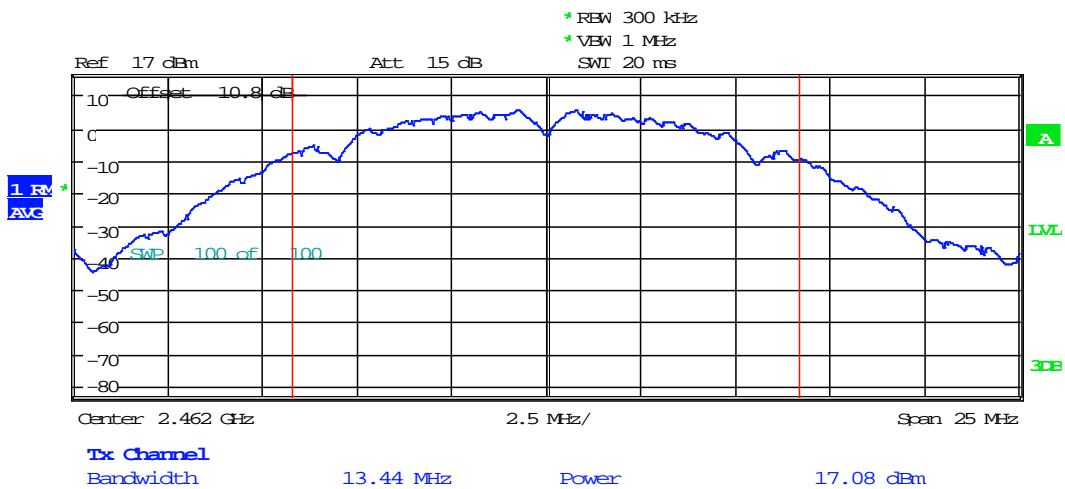

Plot 2. 4

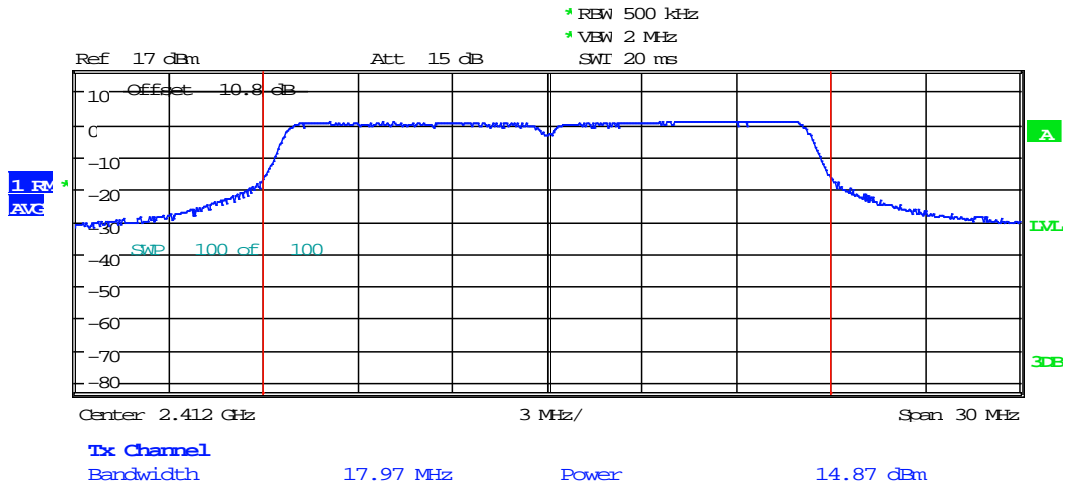

Plot 2. 5

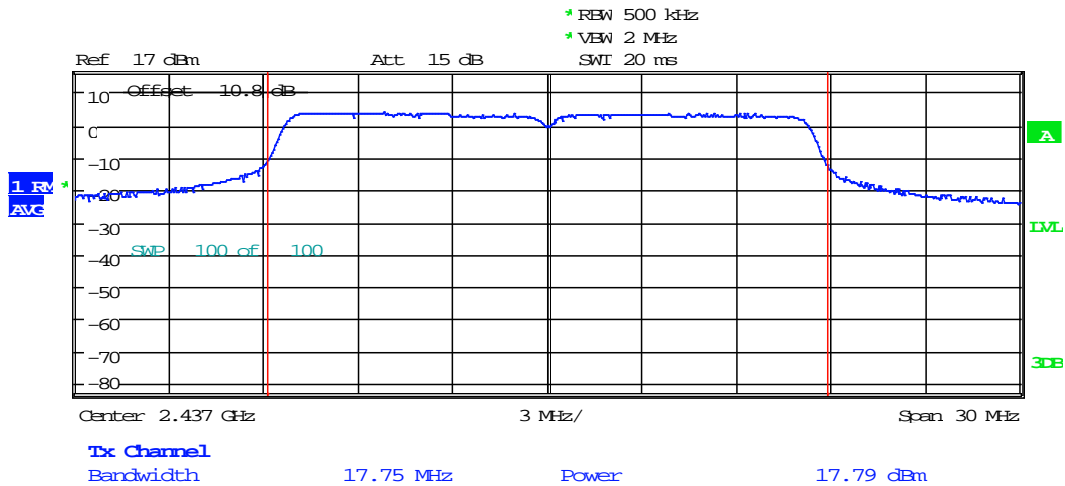

Plot 2.6

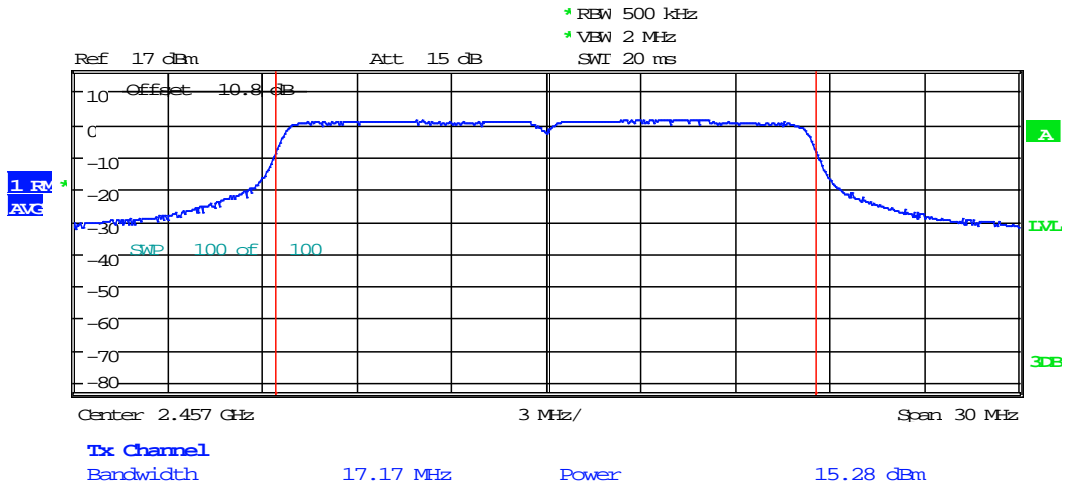

Plot 2.7

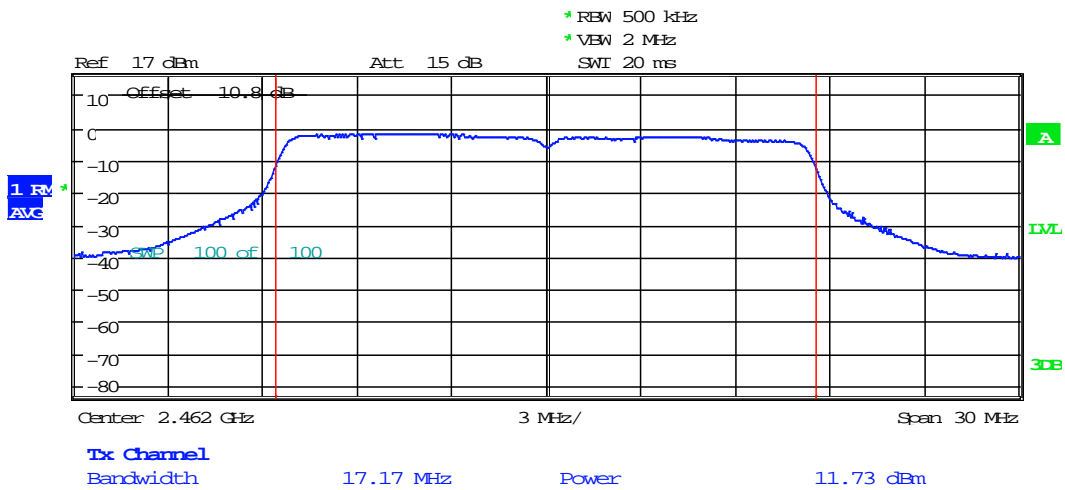

Plot 2. 8

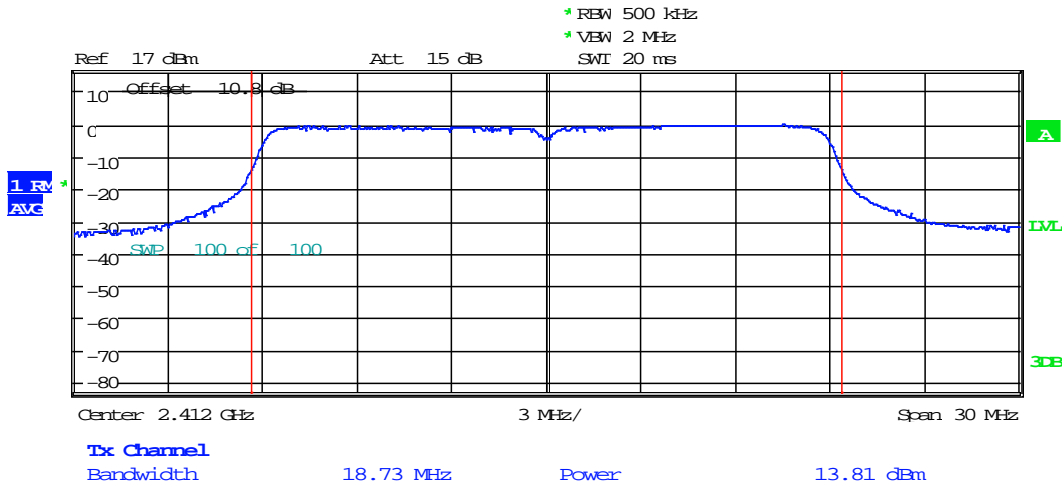

Plot 2. 9

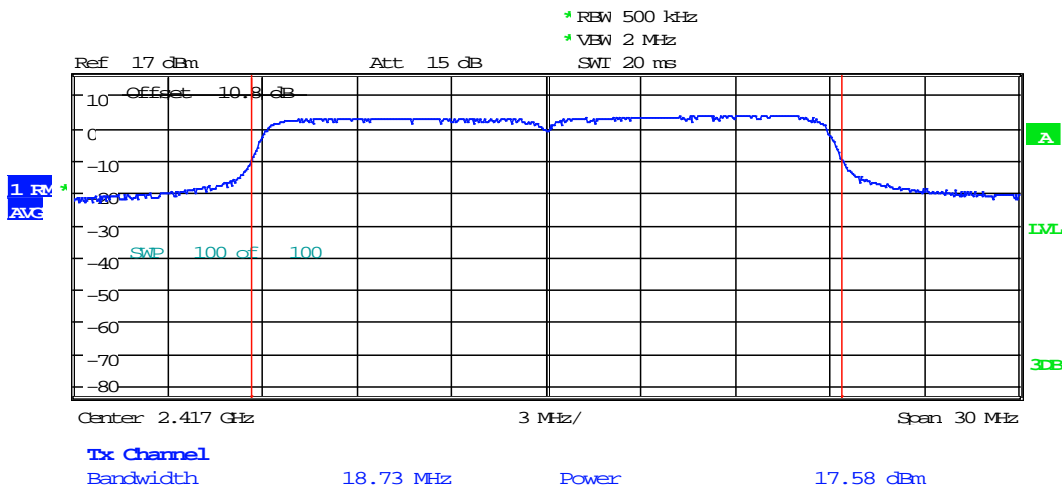

Plot 2. 10

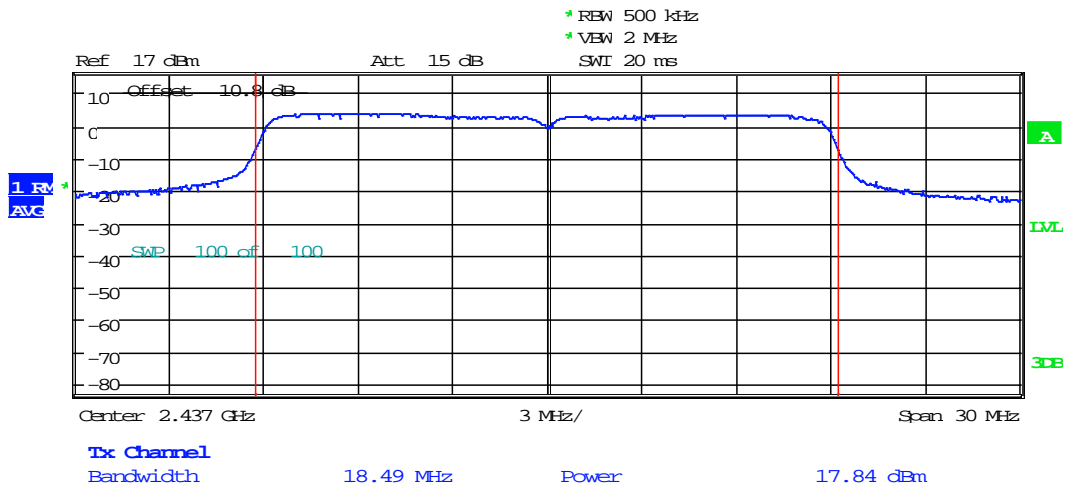

Plot 2. 11

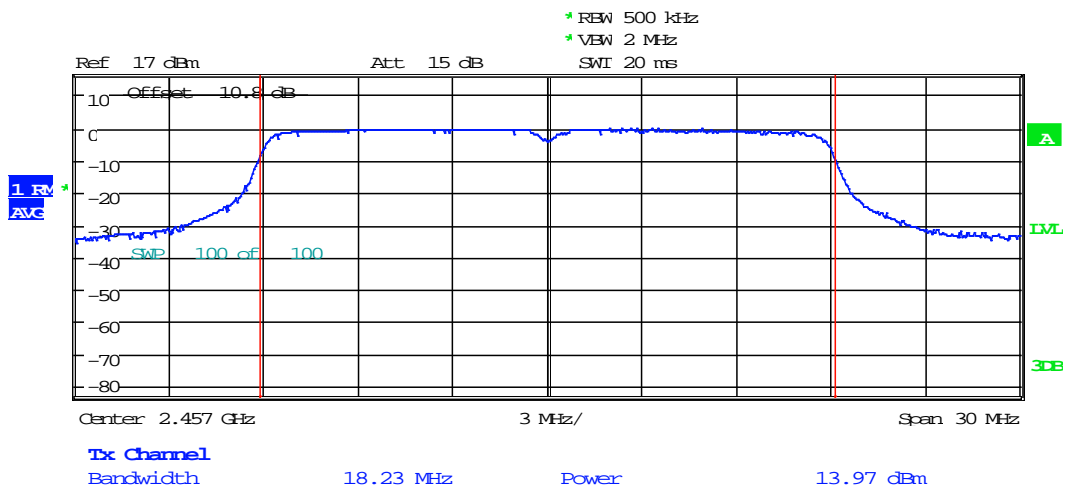

Plot 2. 12

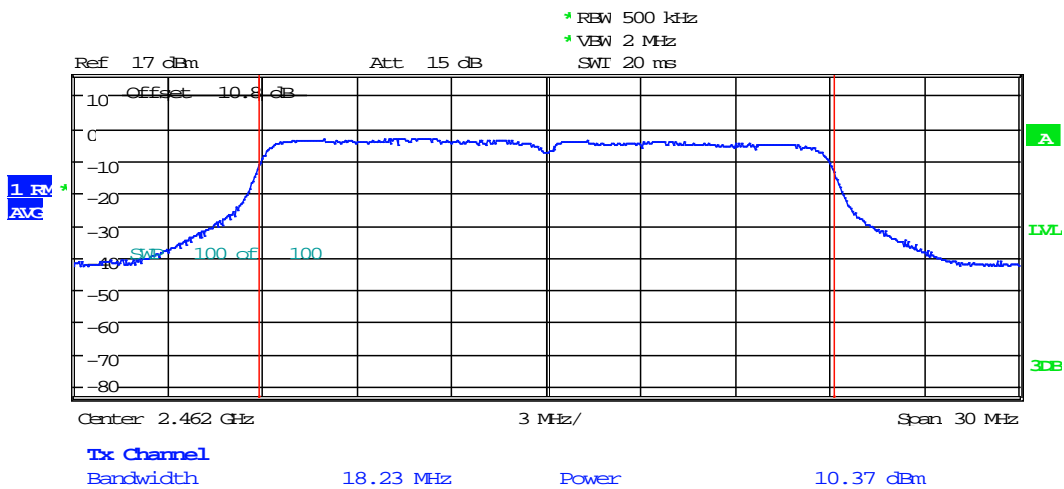

Plot 2. 13

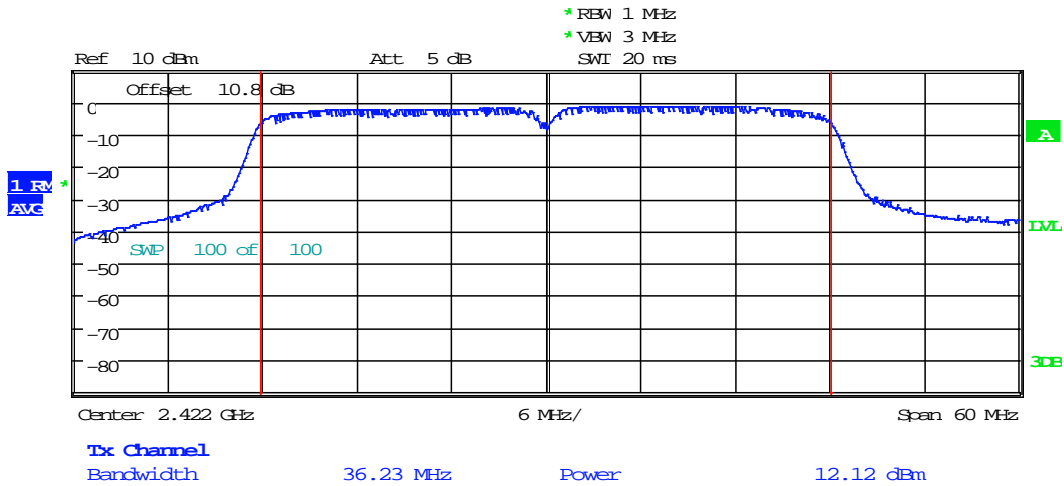

Plot 2. 14

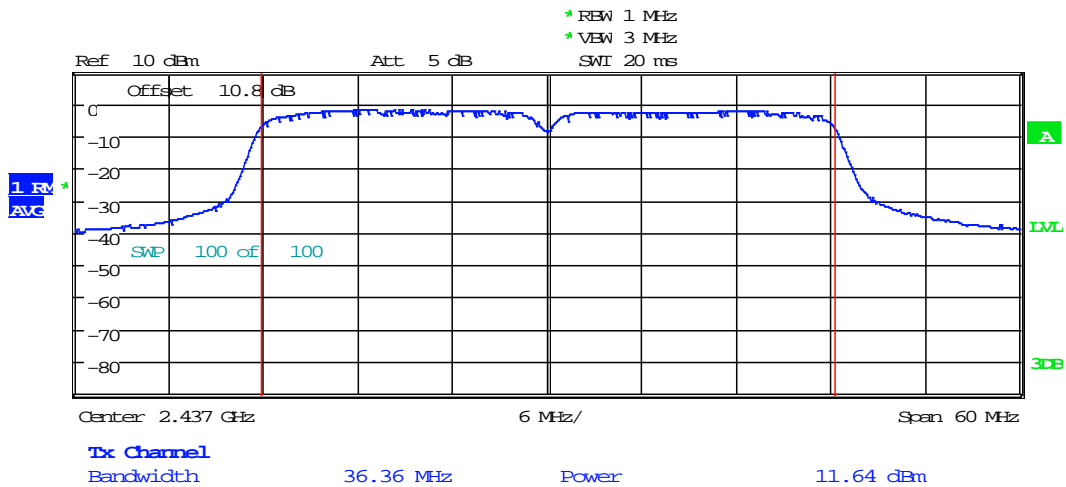

Plot 2.15

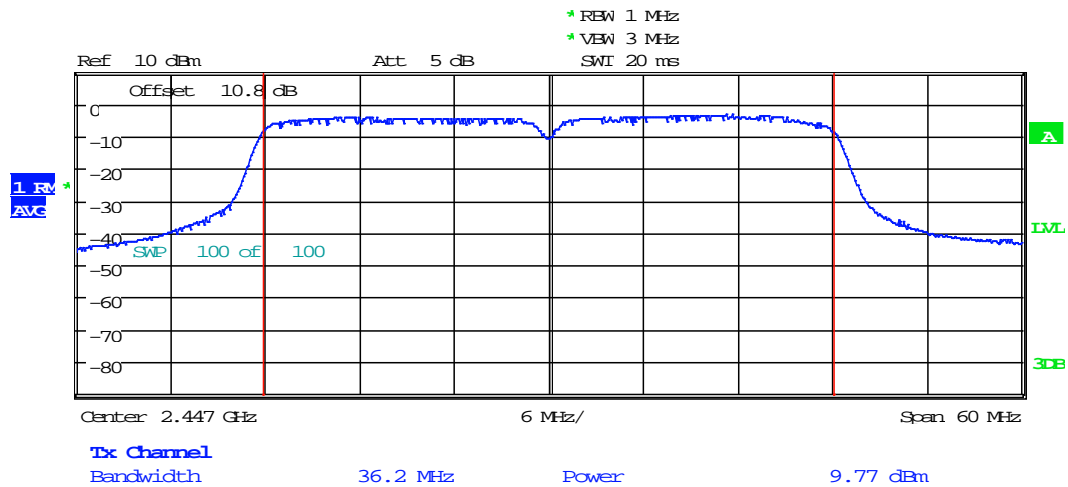

Plot 2.16

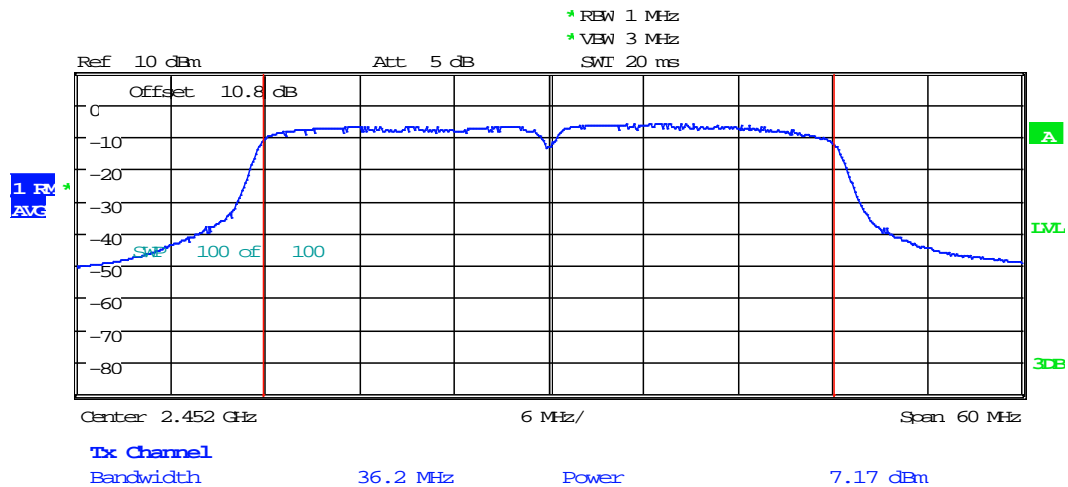

4.3 Power Spectral Density FCC 15.247 (e)

4.3.1 Requirement

For digitally modulated systems, the power spectral density conducted from the intentional radiator to the antenna should not be greater than 8dBm in any 3 kHz band during any time interval of continuous transmission.

4.3.2 Procedure

The antenna port of the EUT was connected to the input of a spectrum analyzer to measure the Transmitter Power Density (PSD).

The procedure described in FCC Publication 558074 D01 DTS Meas Guidance, specifically section 10.2 Method PKPSD (peak PSD).

1. Set analyzer center frequency to DTS channel center frequency.
2. Set the span to 1.5 times the *DTS bandwidth*.
3. Set the RBW to: $3 \text{ kHz} \leq \text{RBW} \leq 100 \text{ kHz}$.
4. Set the VBW $\geq 3 \times \text{RBW}$.
5. Detector = peak.
6. Sweep time = auto couple.
7. Trace mode = max hold.
8. Allow trace to fully stabilize.
9. Use the peak marker function to determine the maximum amplitude level within the RBW.
10. If measured value exceeds limit, reduce RBW (no less than 3 kHz) and repeat.

Test Date:	February 9, 2016
------------	------------------

4.3.3 Test Result

Refer to the following plots for the test result:

Standard	Channel	Frequency MHz	PSD (Peak) dBm	Margin to 8dBm Limit dB	Plot #
802.11b	1	2412	2.16	-5.84	3.1
	6	2437	1.88	-6.12	3.2
	11	2462	-0.15	-8.15	3.3
802.11g	1	2412	-1.07	-9.07	3.4
	6	2437	-0.63	-8.63	3.5
	11	2462	-2.18	-10.18	3.6
802.11n	1	2412	-1.8	-9.8	3.7
	6	2437	-1.79	-9.79	3.7
	11	2462	-3.39	-11.39	3.9
802.11n 40MHz	3	2422	-8.47	-16.47	3.10
	6	2437	-8.84	-16.84	3.11
	9	2452	-9.65	-17.65	3.12



Plot 3. 1

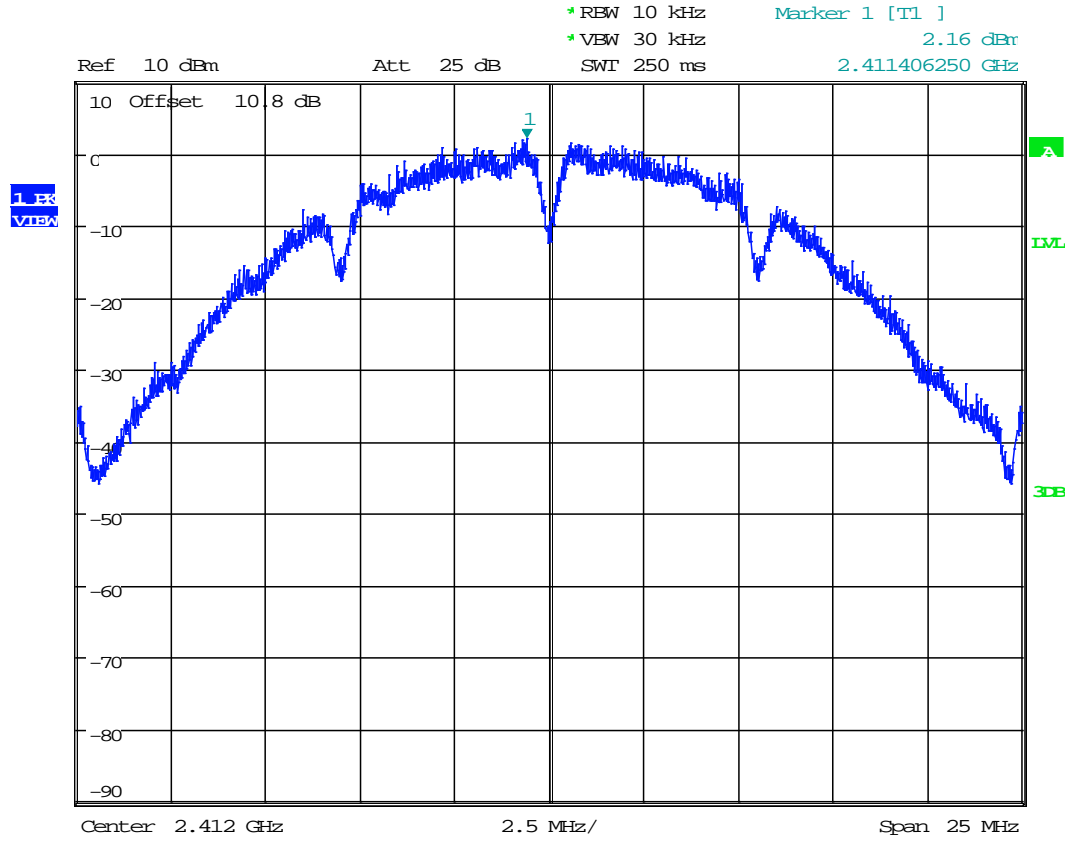

Date: 9.FEB.2016 03:00:44

Plot 3.2

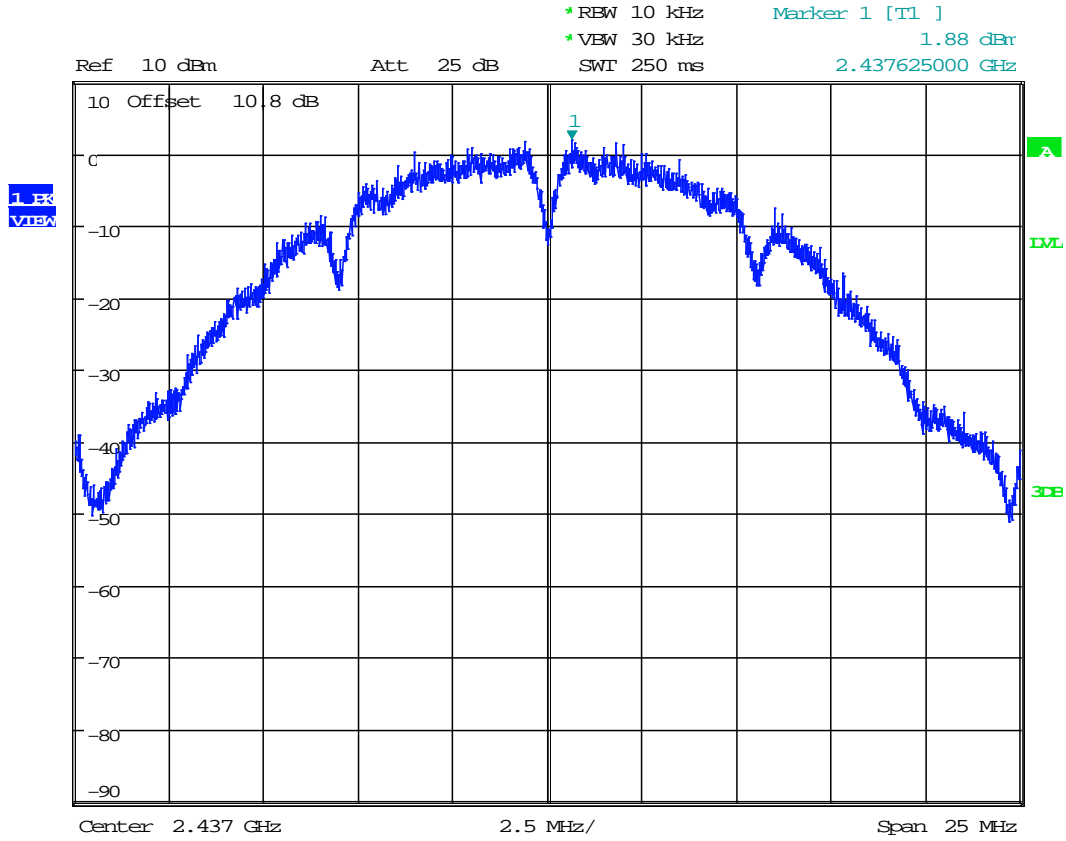

Date: 9.FEB.2016 03:02:16

Plot 3.3

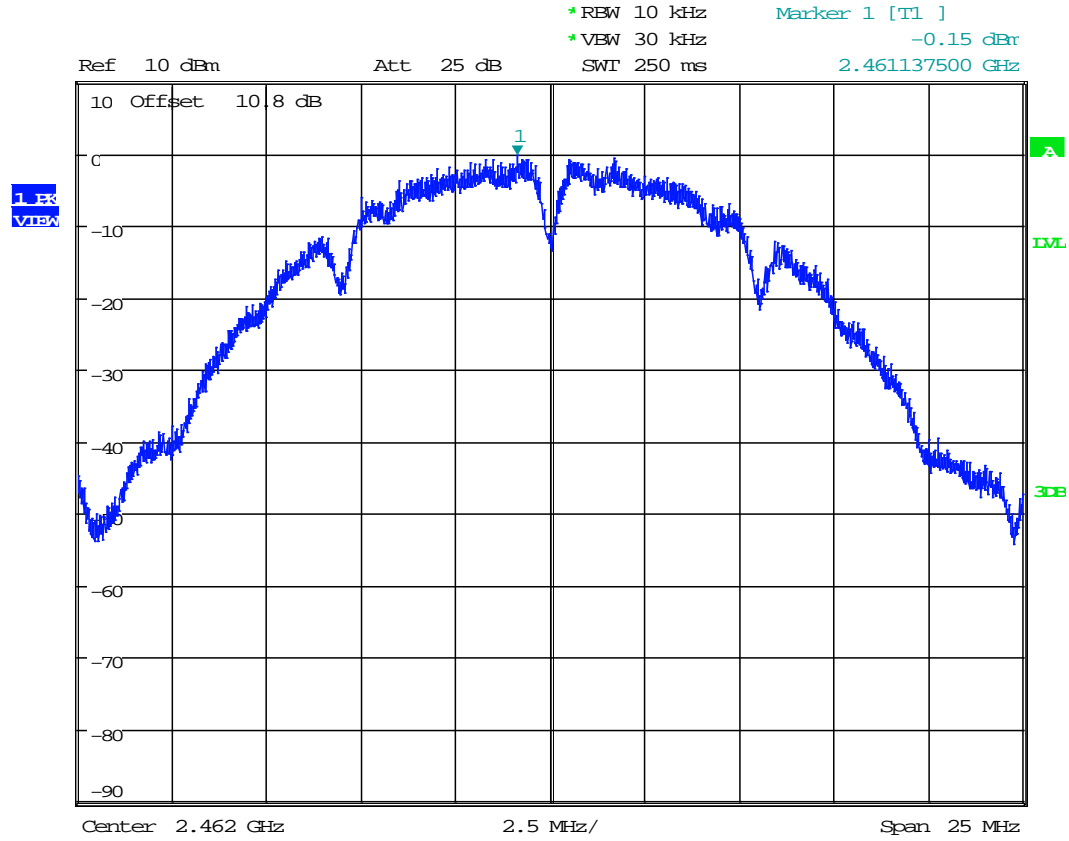

Date: 9.FEB.2016 03:03:55

Plot 3.4

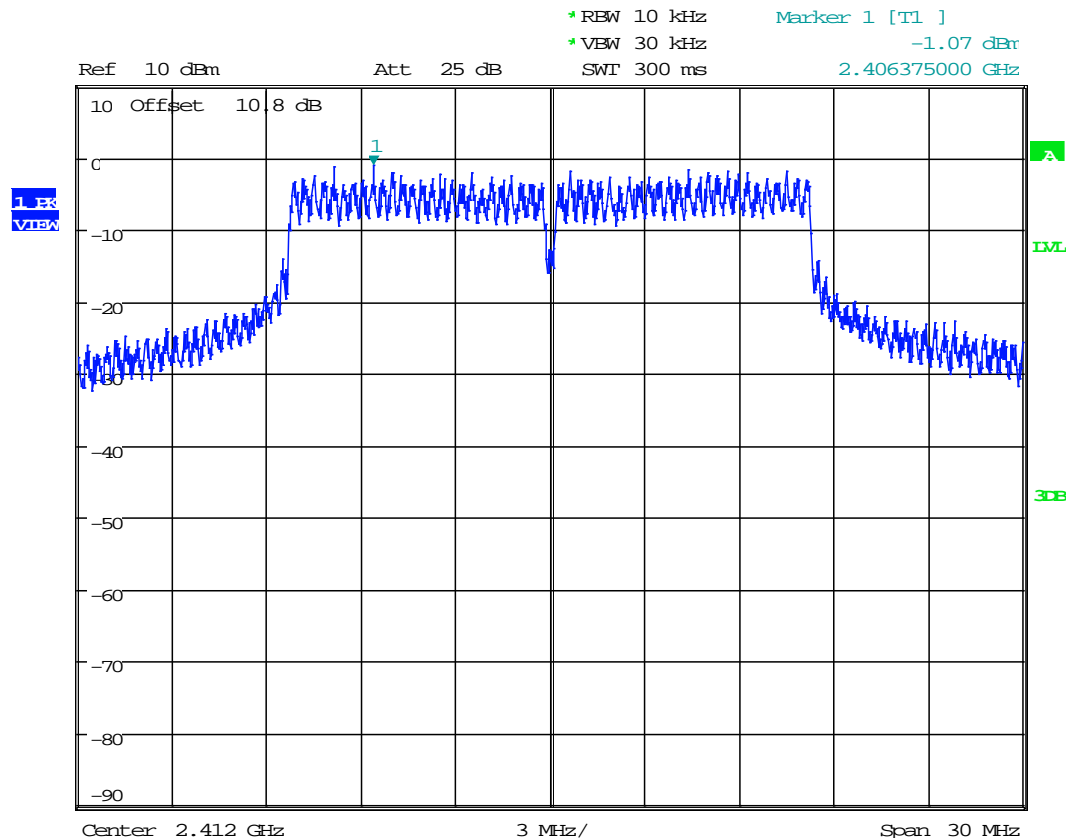

Date: 9.FEB.2016 03:13:04

Plot 3.5

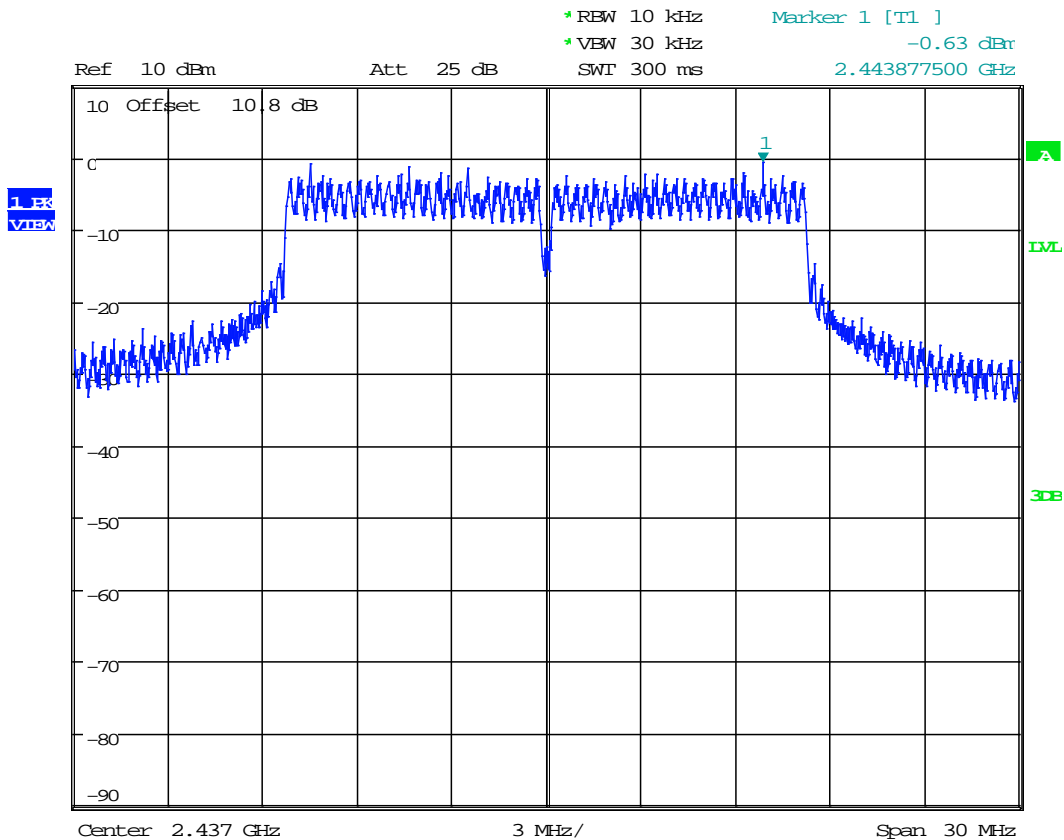

Date: 9.FEB.2016 03:09:51

Plot 3.6

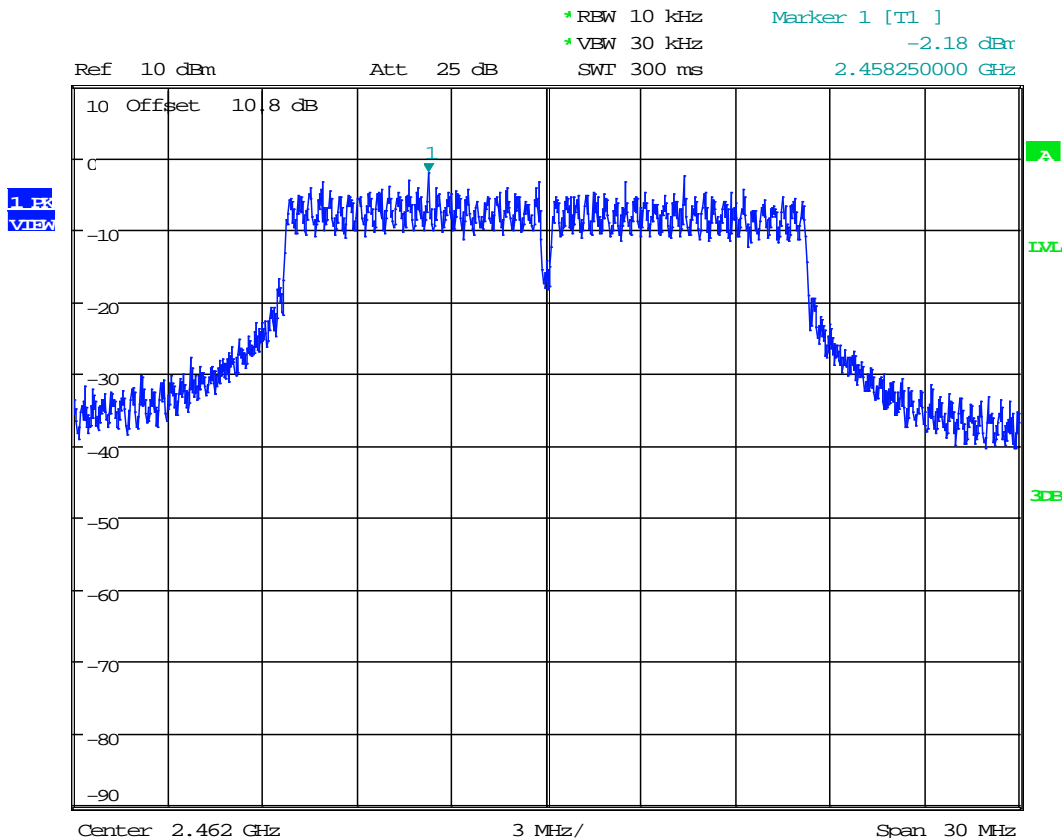

Date: 9.FEB.2016 03:05:39

Plot 3.7

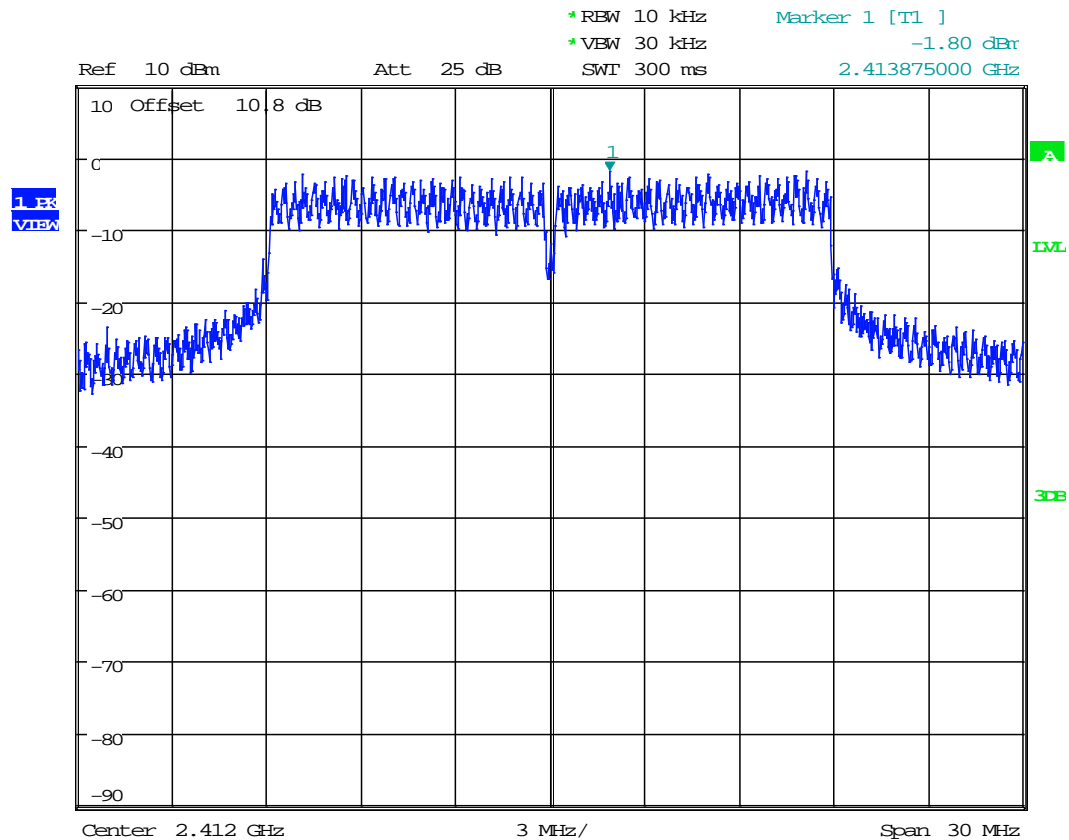

Date: 9.FEB.2016 03:30:07

Plot 3.8

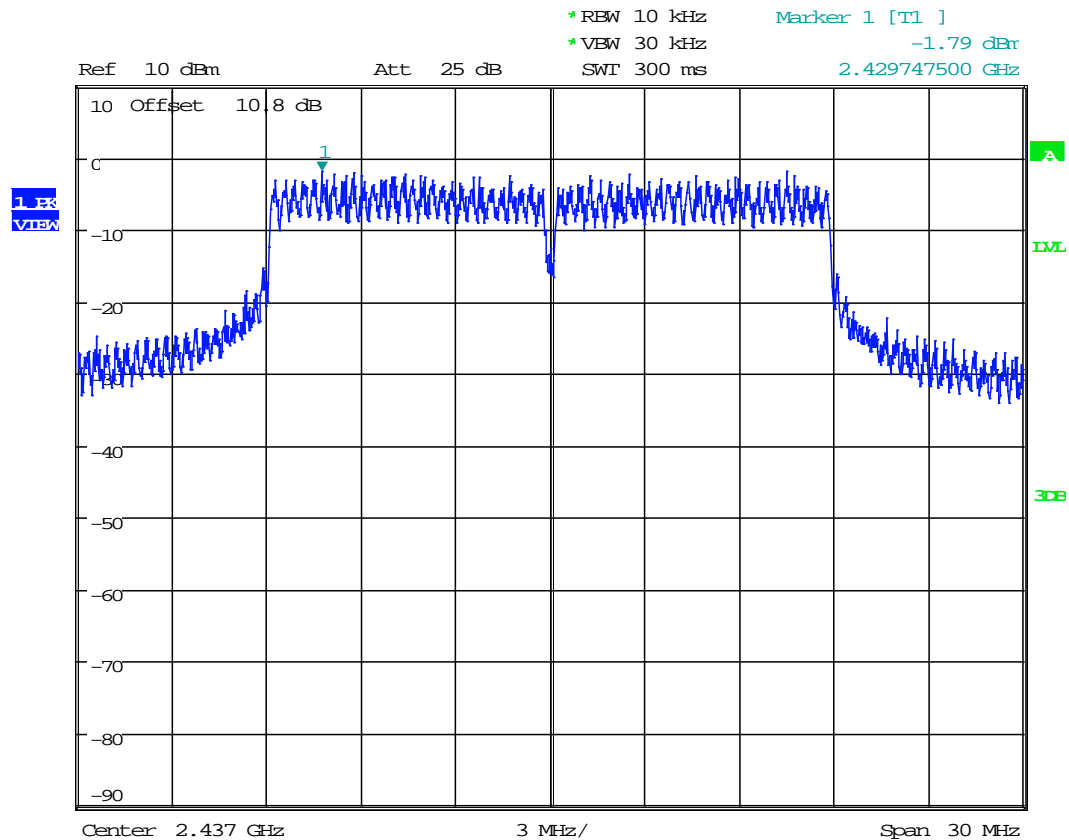

Date: 9.FEB.2016 03:11:22

Plot 3.9

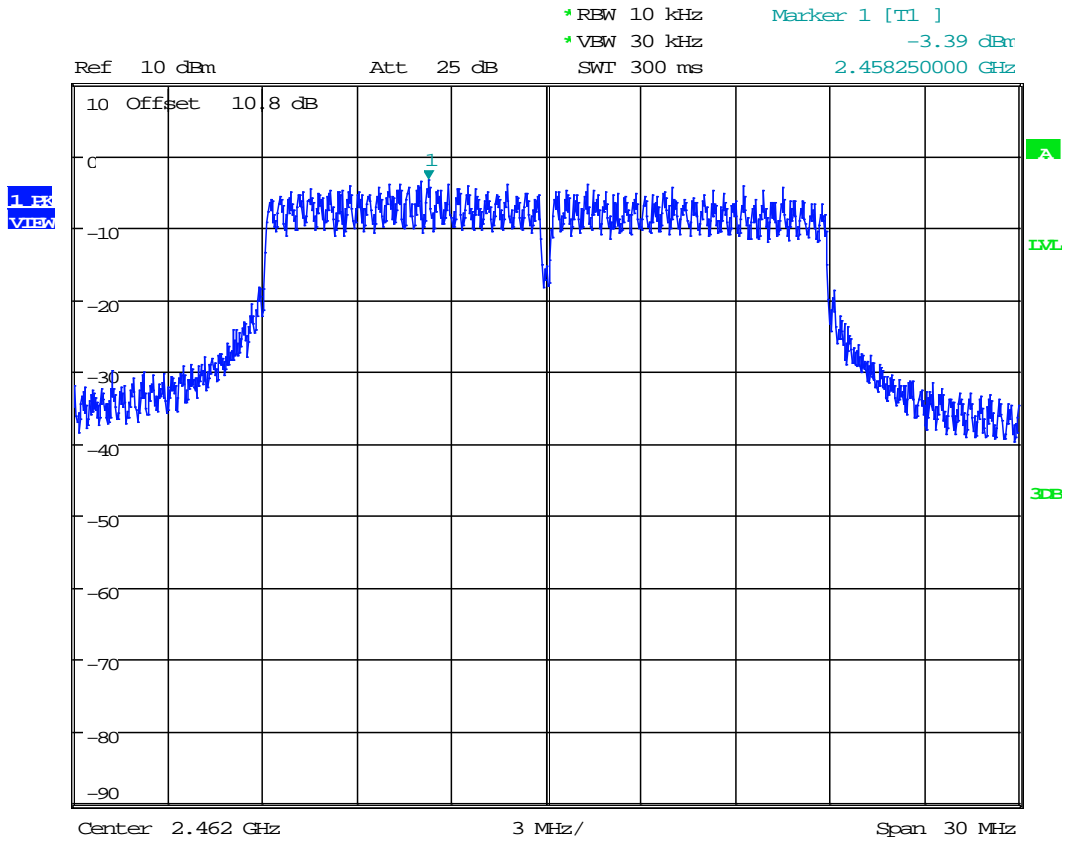

Date: 9.FEB.2016 03:08:05

Plot 3. 10

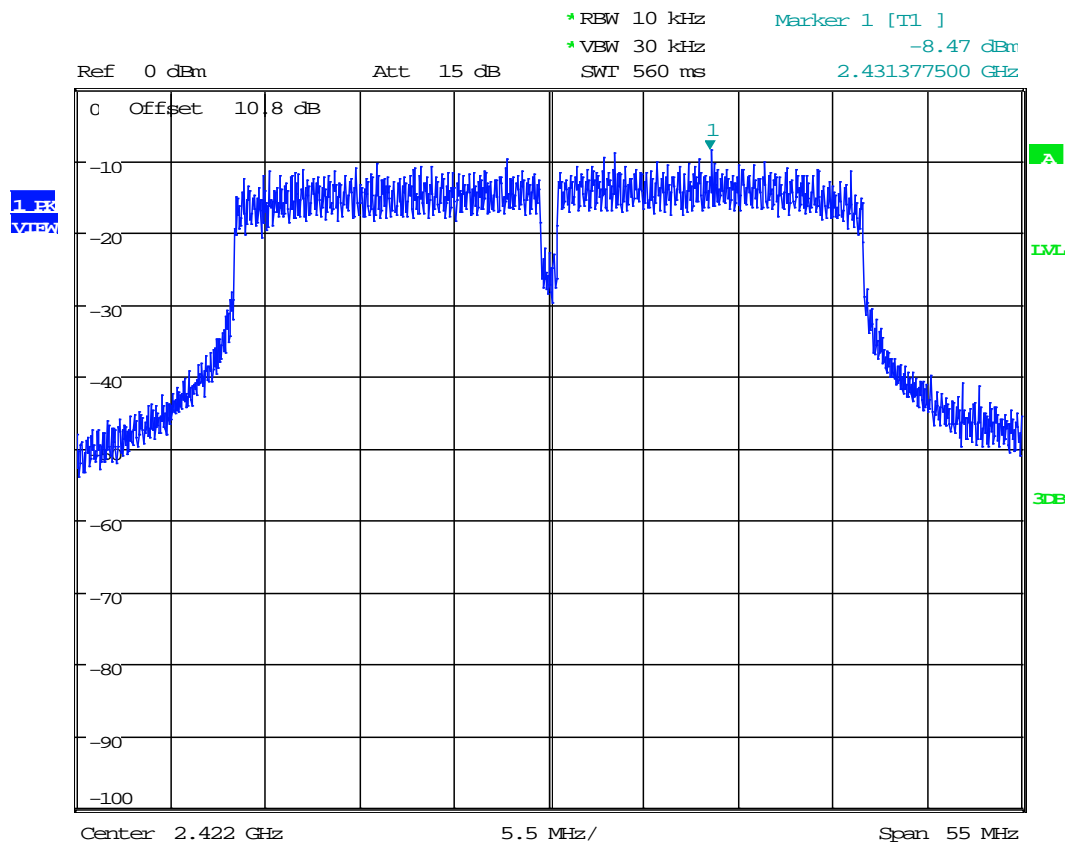

Date: 9.FEB.2016 03:32:09

Plot 3.11

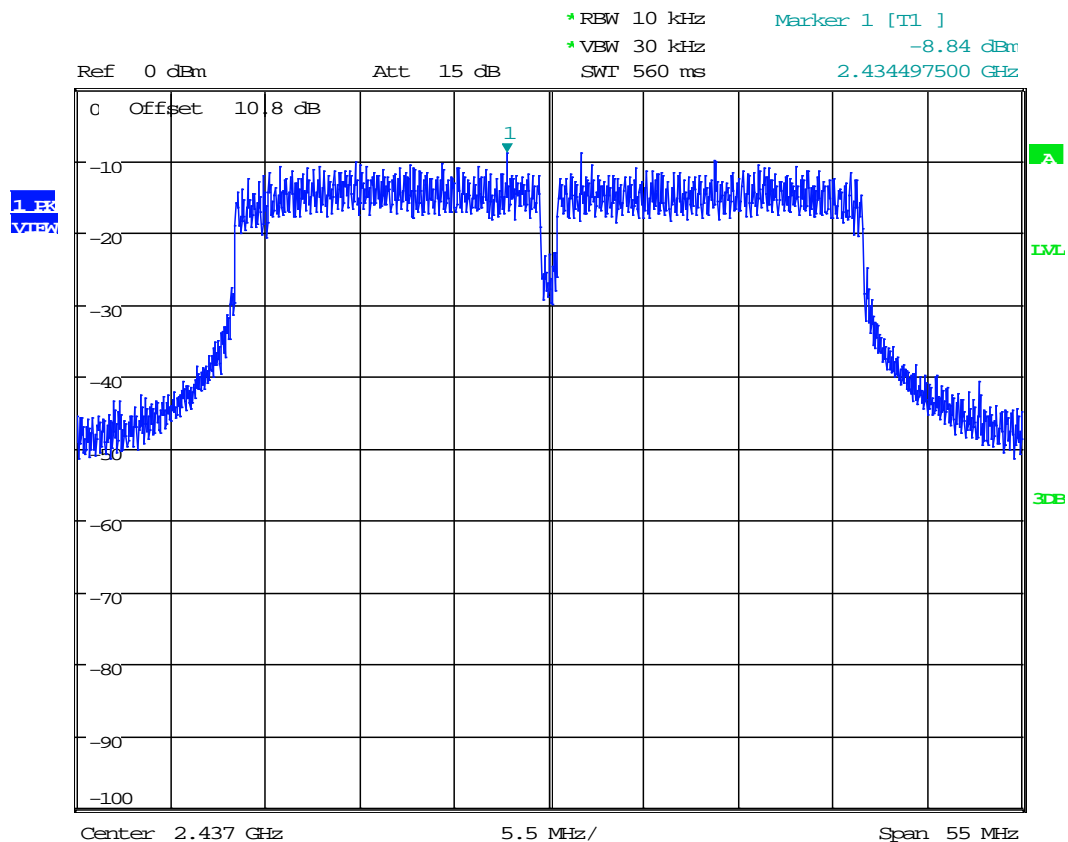

Date: 9.FEB.2016 03:33:41

Plot 3.12

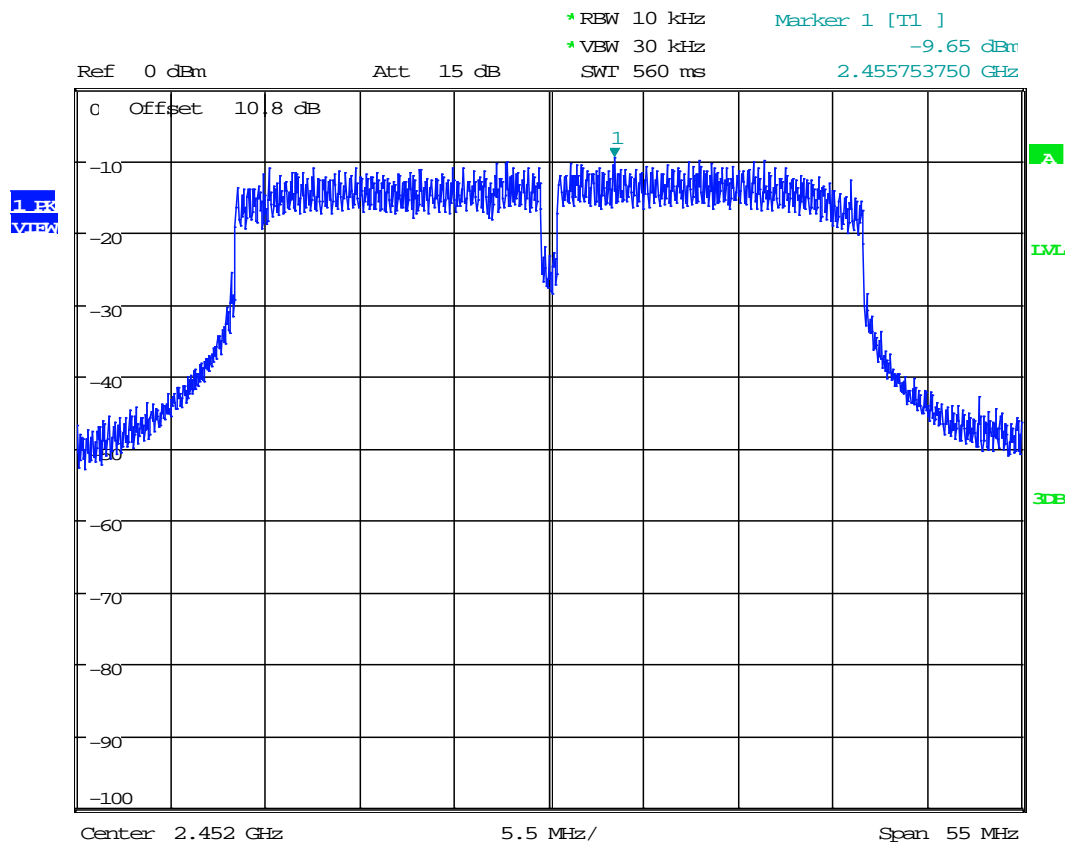

Date: 9.FEB.2016 03:45:39

4.4 Out-of-Band Conducted Emissions
FCC 15.247(d)

4.4.1 Requirement

In any 100 kHz bandwidths outside the EUT pass-band, the RF power shall be at least 20dB (peak) or 30 dB (average) below that of the maximum in-band 100 kHz emissions.

4.4.2 Procedure

A spectrum analyzer was connected to the antenna port of the transmitter. Analyzer Resolution Bandwidth was set to 100 kHz. For each channel investigated, the in-band and out-of-band emission measurements were performed. The out-of-band emissions were measured from 30 MHz to 25 GHz.

4.4.3 Test Result

Refer to the following plots 4.1 – 4.9 for unwanted conducted emissions. The plot shows -30dB attenuation limit line.

Results	Complies
----------------	-----------------

Test Date:	February 4-5, & March 9, 2016
------------	-------------------------------

Plot 4.1
Tx @ 2412MHz 802.11b

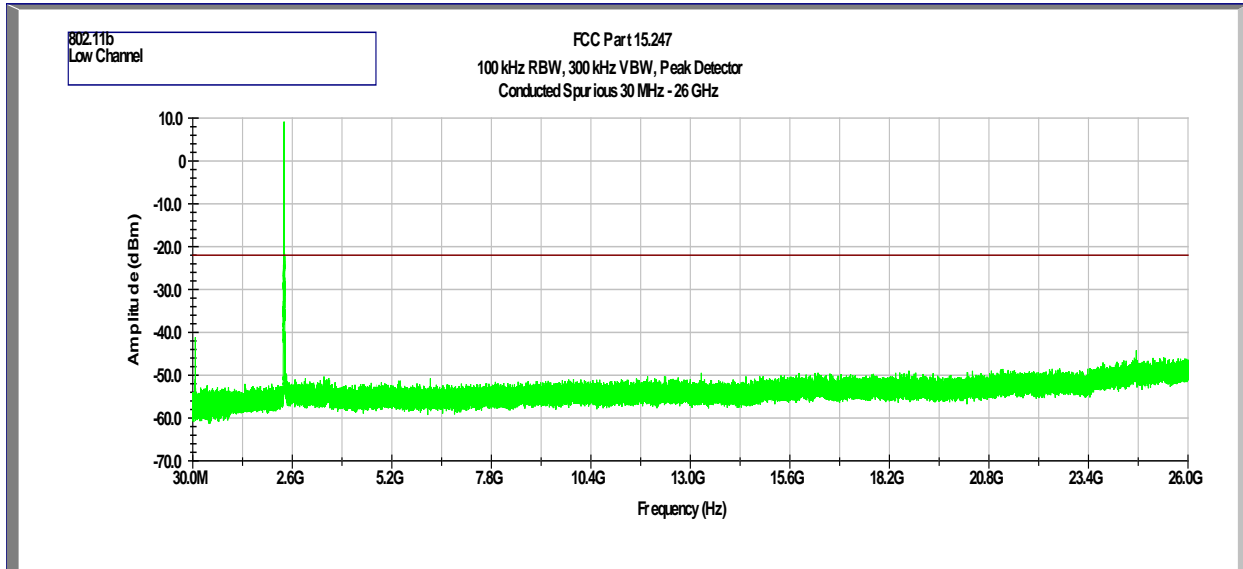

Plot 4.2
Tx @ 2437MHz 802.11b

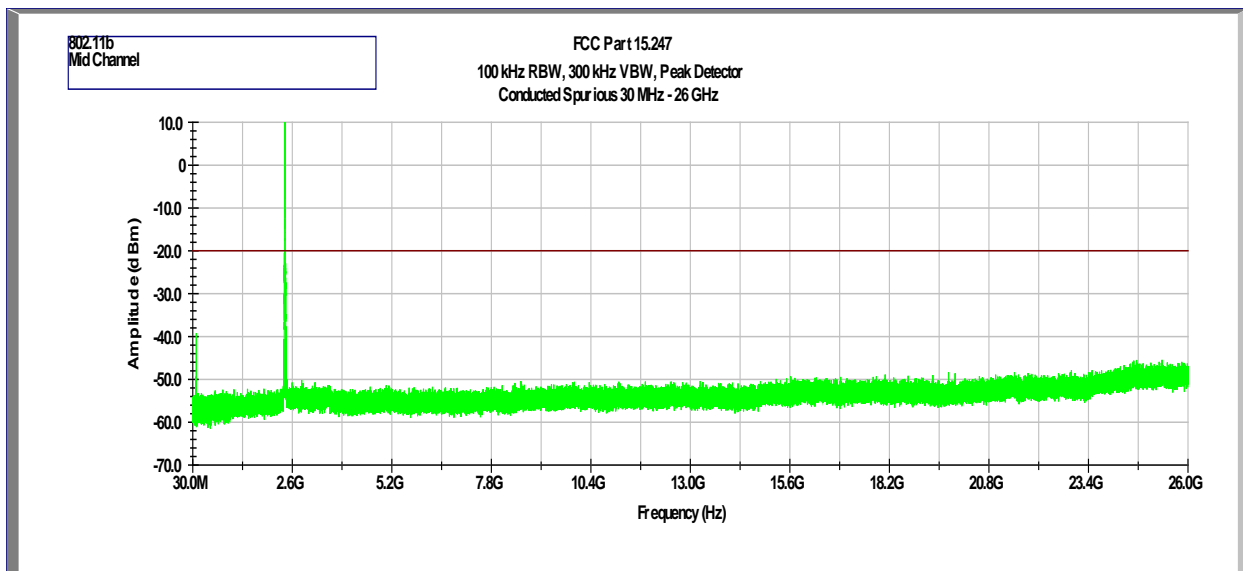

Plot 4.3
Tx @ 2462MHz 802.11b

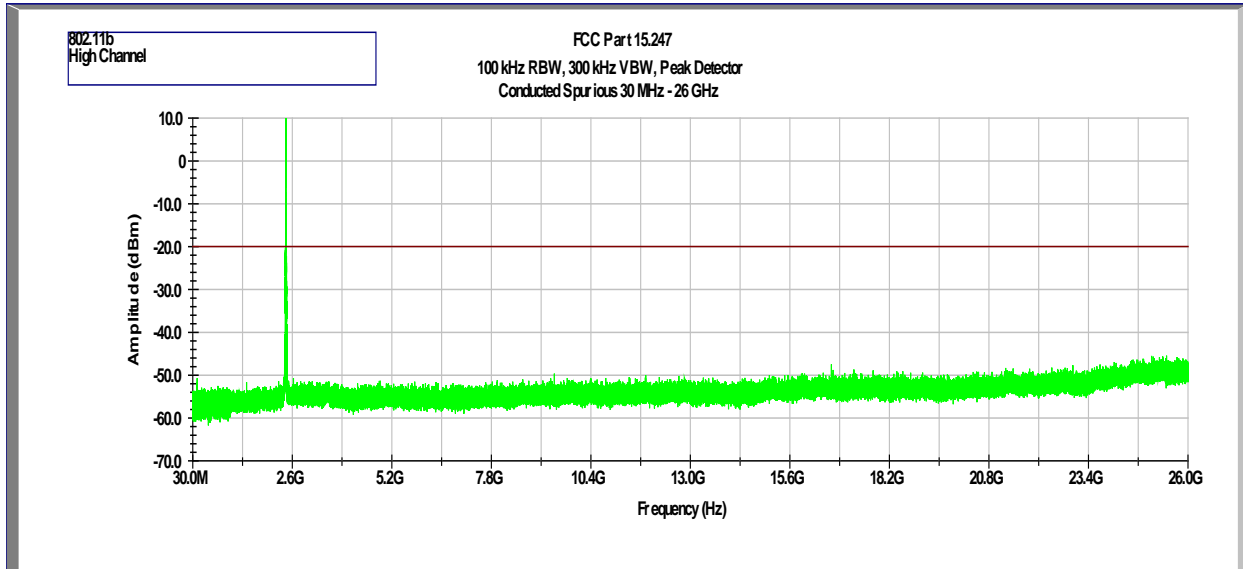

Plot 4.4
Tx @ 2412MHz 802.11g

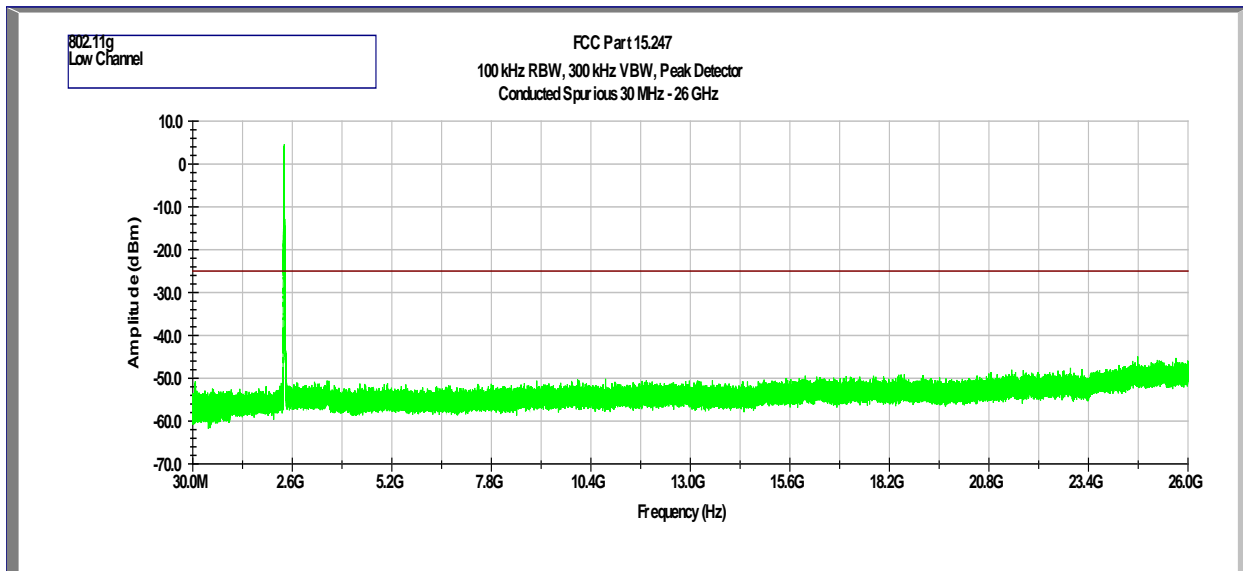

Plot 4.5
Tx @ 2437MHz 802.11g

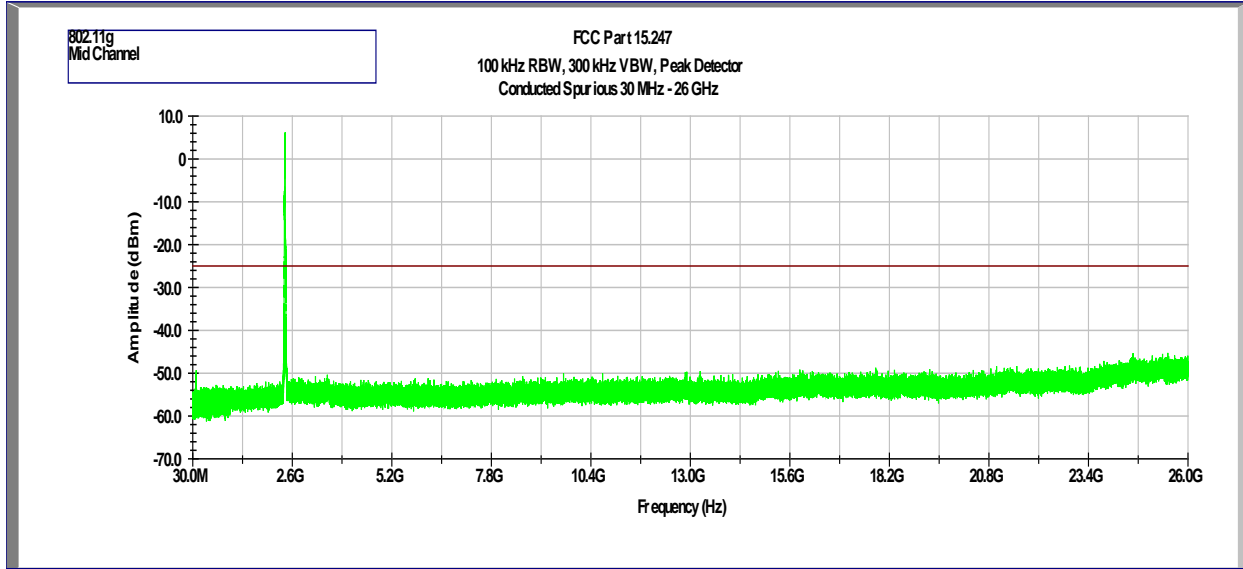

Plot 4.6
Tx @ 2462MHz 802.11g

