



# FCC TEST REPORT

According to

## FCC 47 CFR PART 22 SUBPART H ,PART 24 SUBPART E and PART 27 SUBPART L

Applicant	: Guangzhou Robustel Technologies Co., Limited
Address	: No.263 Zhongshan Ave, Tianhe District, Guangzhou, China 510660
Manufacturer	: Guangzhou Robustel Technologies Co., Limited
Address	: No.263 Zhongshan Ave, Tianhe District, Guangzhou, China 510660
Equipment	: Industrial Cellular Router
Model No.	: R3000-3P
Trade Name	: <b>Robustel</b>
FCC ID	: 2AAJGR3KS

- The test result refers exclusively to the test presented test model / sample.
- Without written approval of **Cerpass Technology Corp.** the test report shall not be reproduced except in full.
- The test report must not be used by the clients to claim product certification approval by **NVLAP** or any agency of the Government.



Table of Contents

- 1. Report of Measurements and Examinations ..... 6
- 2. Test Configuration of Equipment under Test ..... 7
  - 2.1. Feature of Equipment under Test ..... 7
  - 2.2. Test Manner ..... 8
  - 2.3. Description of Test System ..... 8
  - 2.4. General Information of Test ..... 9
  - 2.5. Measurement Uncertainty ..... 9
- 3. Test of Conducted Emission ..... 10
  - 3.1. Test Limit ..... 10
  - 3.2. Test Procedures ..... 10
  - 3.3. Typical Test Setup ..... 11
  - 3.4. Measurement Equipment ..... 11
  - 3.5. Test Result and Data ..... 12
- 4. FIELD STRENGTH OF SPURIOUS RADIATION MEASUREMENT ..... 14
  - 4.1. Test Limit ..... 14
  - 4.2. Test Procedures ..... 14
  - 4.3. Typical Test Setup ..... 15
  - 4.4. Measurement Equipment ..... 16
  - 4.5. Test Result and Data ..... 17
- 5. Occupied Bandwidth ..... 65
  - 5.1. Test Limit ..... 65
  - 5.2. Test Procedures ..... 65
  - 5.3. Test Setup Layout ..... 65
  - 5.4. Measurement Equipment ..... 65
  - 5.5. Test Result and Data ..... 66
- 6. Maximum Peak Output Power ..... 82
  - 6.1. Test Limit ..... 82
  - 6.2. Test Procedure ..... 82
  - 6.3. Test Setup Layout ..... 82
  - 6.4. Measurement Equipment ..... 82
  - 6.5. Test Result and Data ..... 83
- 7. ERP & EIRP MEASUREMENT ..... 86
  - 7.1. Test Limit ..... 86
  - 7.2. Test Procedure ..... 86
  - 7.3. Test Setup Layout ..... 87
  - 7.4. Measurement Equipment ..... 88
  - 7.5. Test Result and Data ..... 89
- 8. OUT OF BAND EMISSION AT ANTENNA TERMINALS ..... 92
  - 8.1. Test Limit ..... 92
  - 8.2. Test Procedure ..... 92
  - 8.3. Test Setup Layout ..... 92
  - 8.4. Measurement Equipment ..... 92
  - 8.5. Test Result and Data ..... 93



---

<b>9. FREQUENCY STABILITY V.S. TEMPERATURE MEASUREMENT .....</b>	<b>117</b>
9.1. Test Limit.....	117
9.2. Test Procedure .....	117
9.3. Test Setup Layout.....	117
9.4. Measurement Equipment .....	117
9.5. Test Result and Data .....	118
<b>1. REQUENCY STABILITY V.S. VOLTAGE MEASUREMENT.....</b>	<b>122</b>
1.1. Test Limit.....	122
1.2. Test Procedure .....	122
1.3. Test Setup Layout.....	122
1.4. Measurement Equipment .....	122
1.5. Test Result and Data .....	123



Document history

Attachment No.	Date	Description



# FCC TEST REPORT

according to

## FCC 47 CFR PART 22 SUBPART H ,PART 24 SUBPART E and PART 27 SUBPART L

Applicant	: Guangzhou Robustel Technologies Co., Limited
Address	: No.263 Zhongshan Ave, Tianhe District, Guangzhou, China 510660
Manufacturer	: Guangzhou Robustel Technologies Co., Limited
Address	: No.263 Zhongshan Ave, Tianhe District, Guangzhou, China 510660
Equipment	: Industrial Cellular Router
Model No.	: R3000-3P
Trade Name	: <b>Robustel</b>
FCC ID	: 2AAJGR3KS

I HEREBY CERTIFY THAT :

The measurements shown in this test report were made in accordance with the procedures given in **ANSI C63.4 – 2009 and TIA/EIA 603** and the energy emitted by this equipment was **passed** **FCC 47 CFR PART 22 SUBPART H ,PART 24 SUBPART E and PART 27 SUBPART L** in both radiated and conducted emission limits.

Testing was carried out on April 01~09, 2014 at **CerpPASS Technology Corp.**

Signature

Miro Chueh/ Technical director



### 1. Report of Measurements and Examinations

FCC 47 CFR PART 22 SUBPART H ,PART 24 SUBPART E and PART 27 SUBPART L ANSI C63.4: 2009 and TIA/EIA 603		
Test Parameter	Test Performed	Remark
Conducted Emission	YES	PASS
Field Strength of Spurious Radiation Measurement	YES	PASS
Occupied Bandwidth	YES	PASS
Maximum Peak Output Power	YES	PASS
ERP & EIRP Measurement	YES	PASS
Out of Band Emission at Antenna Terminals	YES	PASS
Frequency Stability V.S. Temperature Measurement	YES	PASS
Requency Stability V.S. Voltage Measurement	YES	PASS



## 2. Test Configuration of Equipment under Test

### 2.1. Feature of Equipment under Test

Industrial Cellular Router	Model No:	R3000-3P
Operation Frequency Range	EDGE 850:824.2MHz-848.8MHz EDGE 1900:1850.2MHz-1909.8MHz HSUPA/HSDPA BAND5: 826.4MHz – 846.6MHz HSUPA/HSDPA BAND2: 1852.4MHz – 1907.6MHz HSUPA/HSDPA BAND4: 1712.4MHz –1752.6MHz	
Adapter	Model No.:	SYS1357-1812
	Input:	100-240VAC 50/60Hz 1.0A MAX
	Output:	12.0VDC, 1.5A
Antenna	Dipole antenna1 800~2170MHz 3 dBi	
	Dipole antenna2 824~960MHz 1710~2170MHz 3 dBi	
	Cable Type: RG174	
	Length: 3M	
	Connector:SMA Male	
	Dimension:34*107mm	
Weight: 35g		



2.2. Test Manner

<b>Test Manner</b>	
a	During testing, the interface cables and equipment positions were varied according to 47 CFR, Part 2, FCC 47 CFR PART 22 SUBPART H ,PART 24 SUBPART E and PART 27 SUBPART L.
b	Adjust the EUT at the test mode and the test channel. Then test.
<b>The test modes:</b>	
<p>The EUT had been tested under operating condition.          After verification, all tests were carried out with the worst case test modes as shown below except radiated spurious emission below 1GHz and power line conducted emissions below 30MHz, which worst case was in normal link mode only.          EUT staying in continuous transmitting mode was programmed.</p> <p>EDGE 850:          Channel Low (CH128), Channel Mid (CH190) and Channel High (CH251) were chosen for full testing.</p> <p>EDGE 1900:          Channel Low (CH512), Channel Mid (CH661) and Channel High (CH810) were chosen for full testing.</p> <p>HSUPA 850:          Channel Low (CH4132), Channel Mid (CH4183) and Channel High (CH4233) were chosen for full testing.</p> <p>HSUPA 1900:          Channel Low (CH9262), Channel Mid (CH9400) and Channel High (CH9538) were chosen for full testing.</p> <p>HSUPA 1700:          Channel Low (CH1312), Channel Mid (CH1413) and Channel High (CH1513) were chosen for full testing.</p> <p>HSDPA 850:          Channel Low (CH4132), Channel Mid (CH4183) and Channel High (CH4233) were chosen for full testing.</p> <p>HSDPA 1900:          Channel Low (CH9262), Channel Mid (CH9400) and Channel High (CH9538) were chosen for full testing.</p> <p>HSDPA 1700:          Channel Low (CH1312), Channel Mid (CH1413) and Channel High (CH1513) were chosen for full testing.</p>	

2.3. Description of Test System

No.	Device	Manufacturer	Model No.	Description
1	N/A	N/A	N/A	N/A





2.4. General Information of Test

Test Site:	CerpPASS Technology Corp.
Performand Location :	No.66,Tangzhuang Road, Suzhou Industrial Park, Jiangsu 215006, China
NVLAP LAB Code :	200814-0
FCC Registration Number :	916572, 331395
IC Registration Number :	7290A-1, 7290A-2
VCCI Registration Number :	T-1945 for Telecommunication Test C-2919 for Conducted emission test R-2670 for Radiated emission test below 1GHz G-227 for Radiated emission test above 1GHz

Laboratory accreditation



2.5. Measurement Uncertainty

Measurement Item	Measurement Frequency	Polarization	Uncertainty
Conducted Emission	9 kHz ~ 30 MHz	LINE/NEUTRAL	±2.71 dB
Radiated Emission	30 MHz ~ 25GHz	Vertical	±4.11 dB
		Horizontal	±4.10 dB
Occupied Bandwidth	---	---	±7500 Hz
Maximum Peak Output Power	---	---	±1.4 dB
Band Edges	---	---	±2.2 dB
Power Spectral Density	---	---	±2.2 dB



### 3. Test of Conducted Emission

#### 3.1. Test Limit

Conducted Emissions were measured from 150 kHz to 30 MHz with a bandwidth of 9 KHz on the 120 VAC power and return leads of the EUT according to the methods defined in ANSI C63.4-2003 Section 3.1. The EUT was placed on a nonmetallic stand in a shielded room 0.8 meters above the ground plane as shown in section 2.2. The interface cables and equipment positioning were varied within limits of reasonable applications to determine the position produced maximum conducted emissions.

Frequency (MHz)	Quasi Peak (dB $\mu$ V)	Average (dB $\mu$ V)
0.15 – 0.5	66-56*	56-46*
0.5 – 5.0	56	46
5.0 – 30.0	60	50

\*Decreases with the logarithm of the frequency.

#### 3.2. Test Procedures

1. The EUT was placed on a table, which is 0.8m above ground plane.
2. Maximum procedure was performed on the six highest emissions to ensure EUT compliance.
3. Repeat above procedures until all frequency measured were complete.



### 3.3. Typical Test Setup

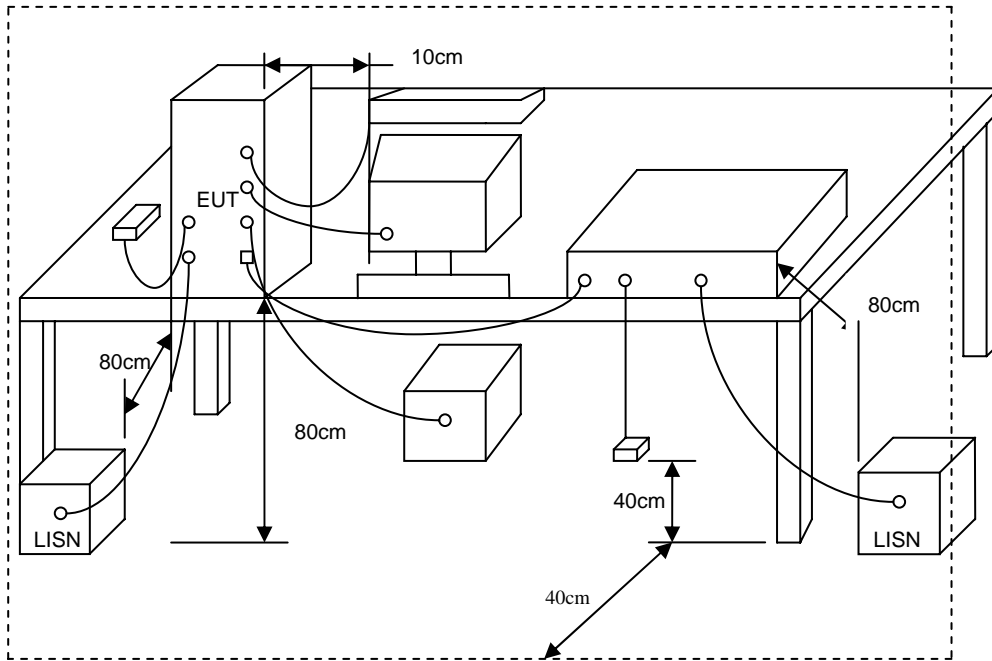

### 3.4. Measurement Equipment

Instrument	Manufacturer	Model No.	Serial No.	Calibration Date	Valid Date.
Test Receiver	R&S	ESCI	100565	2013.11.05	2014.11.04
AMN	R&S	ESH2-Z5	100182	2013.11.05	2014.11.04
Two-Line V-Network	R&S	ENV216	100325	2014.03.10	2015.03.09
ISN	FCC	FCC-TLISN-T 2-02	20379	2013.06.25	2014.06.24
ISN	FCC	FCC-TLISN-T 4-02	20380	2013.06.25	2014.06.24
ISN	FCC	FCC-TLISN-T 8-02	20381	2013.07.09	2014.07.08
ISN	TESEQ	ISN ST08	30175	2013.09.13	2014.09.12
Current Probe	R&S	EZ-17	100303	2014.03.10	2015.03.09
Passive Voltage Probe	R&S	ESH2-Z3	100026	2014.03.10	2015.03.09
Attenuator	R&S	ESH3-Z2	100529	2014.03.10	2015.03.09
Temperature/ Humidity Meter	Zhicheng	ZC1-11	CEP-TH-004	2014.03.10	2015.03.09



3.5. Test Result and Data

Test Mode :	Normal Link	Phase :	Line
Temperature :	20°C	Humidity:	51%
Pressur(mbar) :	1002	Date:	2014-04-09

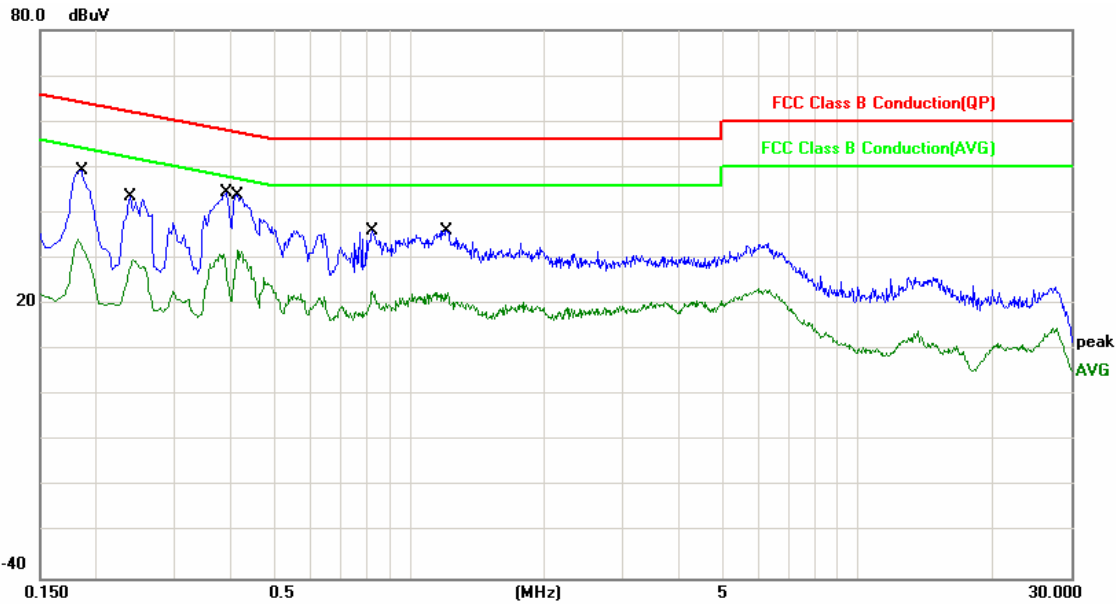

No.	Frequency (MHz)	Factor (dB)	Reading (dBuV)	Level (dBuV)	Limit (dBuV)	Margin (dB)	Detector
1	0.1820	10.12	37.87	47.99	64.39	-16.40	QP
2	0.1820	10.12	21.62	31.74	54.39	-22.65	AVG
3	0.2300	10.12	30.68	40.80	62.45	-21.65	QP
4	0.2300	10.12	12.28	22.40	52.45	-30.05	AVG
5	0.3100	10.14	24.90	35.04	59.97	-24.93	QP
6	0.3100	10.14	7.22	17.36	49.97	-32.61	AVG
7	0.3780	10.15	32.97	43.12	58.32	-15.20	QP
8	0.3780	10.15	20.09	30.24	48.32	-18.08	AVG
9	0.4620	10.16	26.13	36.29	56.66	-20.37	QP
10	0.4620	10.16	10.82	20.98	46.66	-25.68	AVG
11	1.1940	10.16	20.17	30.33	56.00	-25.67	QP
12	1.1940	10.16	8.24	18.40	46.00	-27.60	AVG

Note: Measurement Level = Reading Level + Correct Factor



Test Mode :	Normal Link	Phase :	Neutral
Temperature :	20°C	Humidity :	51%
Pressur(mbar) :	1002	Date :	2014-04-09

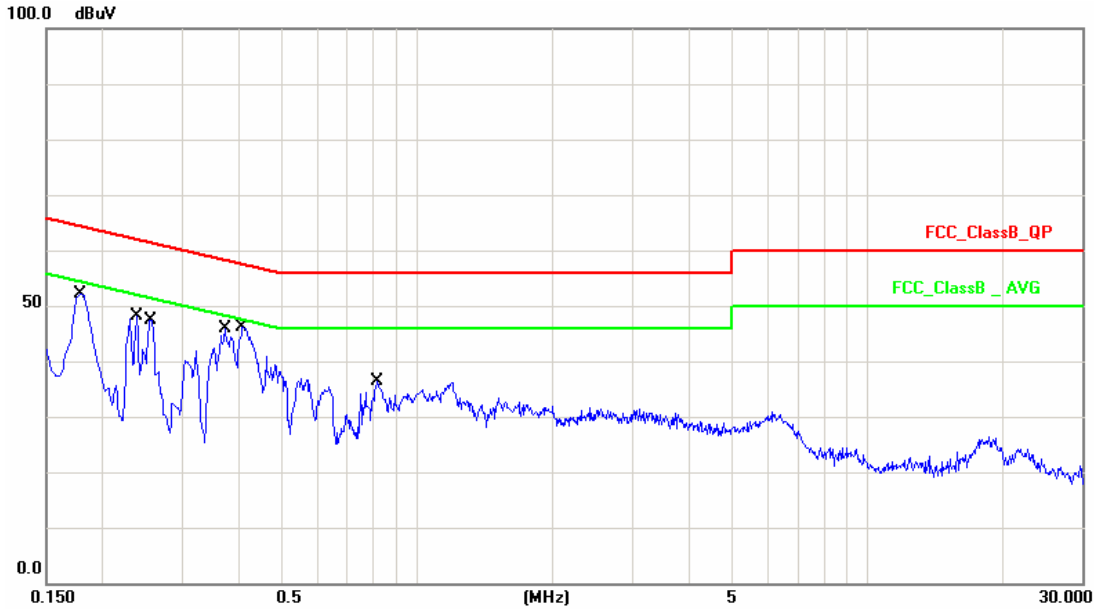

No.	Frequency (MHz)	Factor (dB)	Reading (dBuV)	Level (dBuV)	Limit (dBuV)	Margin (dB)	Detector
1	0.1780	10.13	38.02	48.15	64.57	-16.42	QP
2	0.1780	10.13	20.54	30.67	54.57	-23.90	AVG
3	0.2380	10.13	33.12	43.25	62.16	-18.91	QP
4	0.2380	10.13	16.97	27.10	52.16	-25.06	AVG
5	0.2562	10.13	31.44	41.57	61.55	-19.98	QP
6	0.2562	10.13	14.21	24.34	51.55	-27.21	AVG
7	0.3740	10.15	31.22	41.37	58.41	-17.04	QP
8	0.3740	10.15	18.66	28.81	48.41	-19.60	AVG
9	0.4100	10.15	32.93	43.08	57.65	-14.57	QP
10	0.4100	10.15	20.34	30.49	47.65	-17.16	AVG
11	0.8139	10.16	22.53	32.69	56.00	-23.31	QP
12	0.8139	10.16	11.76	21.92	46.00	-24.08	AVG

Note: Measurement Level = Reading Level + Correct Factor



## 4. FIELD STRENGTH OF SPURIOUS RADIATION MEASUREMENT

### 4.1. Test Limit

The power of any emission outside of the authorized operating frequency ranges must be attenuated below the transmitting power (P) by a factor of at least  $43 + 10\log(P)$  dB.

It is measured by means of a calibrated spectrum analyzer and scanned from 30 MHz up to a frequency including its 10th harmonic.

### 4.2. Test Procedures

Final radiation measurements were made on a three-meter, Semi Anechoic Chamber. The EUT system was placed on a nonconductive turntable which is 0.8 meters height, top surface 1.0 x 1.5 meter. The spectrum was examined from 250 MHz to 2.5 GHz in order to cover the whole spectrum below 10th harmonic which could generate from the EUT. During the test, EUT was set to transmit continuously & Measurements spectrum range from 30 MHz to 26.5 GHz is investigated. For measurements below 1 GHz the resolution bandwidth is set to 100 kHz for peak detection measurements or 120 kHz for quasi-peak detection measurements. Peak detection is used unless otherwise noted as quasi-peak. For measurements above 1 GHz the resolution bandwidth is set to 1 MHz, and then the video bandwidth is set to 1 MHz for peak measurements and 10 Hz for average measurements. A nonconductive material surrounded the EUT to supporting the EUT for standing on three orthogonal planes. At each condition, the EUT was rotated 360 degrees, and the antenna was raised and lowered from one to four meters to find the maximum emission levels. Measurements were taken using both horizontal and vertical antenna polarization.

For testing above 1GHz, the emission level of the EUT in peak mode was 20dB lower than average limit (that means the emission level in peak mode also complies with the limit in average mode), then testing will be stopped and peak values of EUT will be reported, otherwise, the emissions will be measured in average mode again and reported.

Appropriate preamplifiers were used for improving sensitivity and precautions were taken to avoid

overloading or desensitizing the spectrum analyzer. No post – detector video filters were used in the test. The spectrum analyzer's 6 dB bandwidth was set to 1 MHz, and the analyzer was operated in the peak detection mode, for frequencies both below and up 1 GHz. The average levels were obtained by subtracting the duty cycle correction factor from the peak readings.

The following procedures were used to convert the emission levels measured in decibels



referenced to 1 microvolt (dBuV) into field intensity in micro volts pre meter (uV/m).

The actual field intensity in decibels referenced to 1 microvolt in to field intensity in micro volts per meter (dBuV/m). The actual field intensity in decibels referenced to 1 microvolt per meter (dBuV/m) is determined by algebraically adding the measured reading in dBuV, the antenna factor (dB), and cable loss (dB) and Subtracting the gain of preamplifier (dB) is auto calculate in spectrum analyzer.

$$(1) \text{ Amplitude (dBuV/m) = FI (dBuV) +AF (dBuV) +CL (dBuV)-Gain (dB)}$$

FI= Reading of the field intensity.

AF= Antenna factor.

CL= Cable loss.

P.S Amplitude is auto calculate in spectrum analyzer.

$$(2) \text{ Actual Amplitude (dBuV/m) = Amplitude (dBuV)-Dis(dB)}$$

The FCC specified emission limits were calculated according the EUT operating frequency and by following linear interpolation equations:

(a) For fundamental frequency : Transmitter Output < +30dBm

(b) For spurious frequency : Spurious emission limits = fundamental emission limit /10

### 4.3. Typical Test Setup

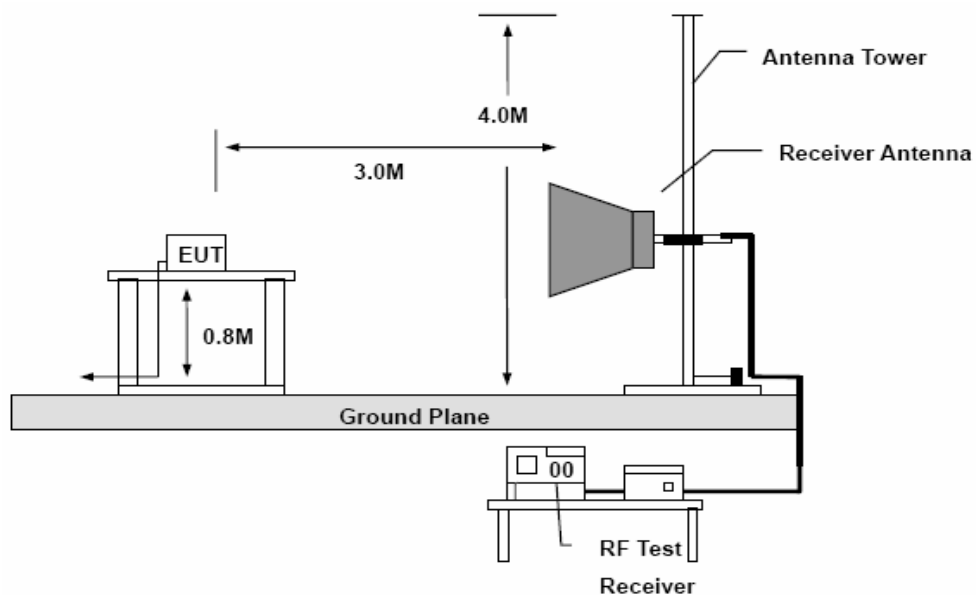



**4.4. Measurement Equipment**

Instrument	Model No.	Manufacturer	Serial No.	Calibration Date	Valid Date.
EMI Test Receiver	R&S	ESCI	100563	2014.03.10	2015.03.09
H64 Preamplifier	HP	8447F	3113A05582	2014.03.10	2015.03.09
Preamplifier	Agilent	8449B	3008A02342	2014.03.10	2015.03.09
Ultra Broadband Antenna	R&S	HL562	100362	2013.05.03	2014.05.02
Broad-Band Horn Antenna	Schwarzbeck	BBHA9120D	9120D-619	2013.05.03	2014.05.02
Broad-Band Horn Antenna	Schwarzbeck	BBHA9170	9170-347	2013.05.03	2014.05.02
Spectrum Analyzer	Agilent	E4407B	MY44211883	2013.09.25	2014.09.25
Temperature/ Humidity Meter	Zhicheng	ZC1-11	CEP-TH-002	2014.03.10	2015.03.09





**4.5. Test Result and Data**

**Radiated Spurious Emission Measurement Result / Under 1GHz:**

Engineer : Matt	Time : 2014-04-08
Site : EMC Lab AC 102	Margin : 6
Limit : FCC_Part22&24	Probe : VERTICAL/ HORIZONTAL
EUT : Industrial Cellular Router	Note : EDGE 850 / CH 128

Frequency (MHz)	Antenna Polarization	Antenna Terminals level (dBm)	Substitution Antenna Gain (dBd)	Emission level (dBm)	Limit (dBm)	Margin (dB)
37.75	V	-14.65	-11.01	-25.66	-13.00	-12.66
106.29	V	-11.33	-13.44	-24.77	-13.00	-11.77
109.35	V	-10.50	-13.65	-24.15	-13.00	-11.15
127.90	V	-12.28	-14.15	-26.43	-13.00	-13.43
134.35	V	-12.63	-14.47	-27.10	-13.00	-14.10
827.75	V	-25.95	1.87	-24.08	-13.00	-11.08
74.29	H	-10.37	-16.63	-27.00	-13.00	-14.00
86.16	H	-10.25	-15.27	-25.52	-13.00	-12.52
107.35	H	-13.01	-14.25	-27.26	-13.00	-14.26
128.75	H	-11.15	-14.15	-25.30	-13.00	-12.30
312.19	H	-16.84	-9.74	-26.58	-13.00	-13.58
895.36	H	-22.75	-2.44	-25.19	-13.00	-12.19



Engineer : MATT	Time : 2014-04-08
Site : EMC Lab AC 102	Margin : 6
Limit : FCC_Part22&24	Probe : VERTICAL/ HORIZONTAL
EUT : Industrial Cellular Router	Note : EDGE 850 / CH 190

Frequency (MHz)	Antenna Polarization	Antenna Terminals level (dBm)	Substitution Antenna Gain (dBd)	Emission level (dBm)	Limit (dBm)	Margin (dB)
37.16	V	-14.11	-11.29	-25.40	-13.00	-12.40
101.62	V	-13.43	-11.47	-24.90	-13.00	-11.90
111.77	V	-12.36	-13.78	-26.14	-13.00	-13.14
126.29	V	-12.28	-14.15	-26.43	-13.00	-13.43
136.34	V	-13.91	-14.47	-28.38	-13.00	-15.38
817.91	V	-25.16	1.87	-23.29	-13.00	-10.29
75.35	H	-10.35	-16.63	-26.98	-13.00	-13.98
86.51	H	-11.65	-15.27	-26.92	-13.00	-13.92
107.59	H	-10.47	-14.25	-24.72	-13.00	-11.72
126.35	H	-11.75	-14.15	-25.90	-13.00	-12.90
312.19	H	-13.87	-9.74	-23.61	-13.00	-10.61
896.36	H	-22.16	-2.44	-24.60	-13.00	-11.60



Engineer : MATT	Time : 2014-04-08
Site : EMC Lab AC 102	Margin : 6
Limit : FCC_Part22&24	Probe : VERTICAL/ HORIZONTAL
EUT : Industrial Cellular Router	Note : EDGE 850 / CH 251

Frequency (MHz)	Antenna Polarization	Antenna Terminals level (dBm)	Substitution Antenna Gain (dBd)	Emission level (dBm)	Limit (dBm)	Margin (dB)
38.17	V	-14.29	-11.29	-25.58	-13.00	-12.58
106.95	V	-11.54	-13.44	-24.98	-13.00	-11.98
111.25	V	-11.18	-13.78	-24.96	-13.00	-11.96
127.29	V	-12.54	-14.15	-26.69	-13.00	-13.69
136.71	V	-11.85	-14.47	-26.32	-13.00	-13.32
828.18	V	-28.77	1.87	-26.90	-13.00	-13.90
75.75	H	-10.68	-16.63	-27.31	-13.00	-14.31
86.39	H	-10.26	-15.27	-25.53	-13.00	-12.53
107.35	H	-9.54	-14.25	-23.79	-13.00	-10.79
128.19	H	-12.03	-14.15	-26.18	-13.00	-13.18
311.33	H	-16.49	-9.74	-26.23	-13.00	-13.23
897.95	H	-23.39	-2.44	-25.83	-13.00	-12.83



Engineer : MATT	Time :2014-04-08
Site : EMC Lab AC 102	Margin : 6
Limit : FCC_Part22&24	Probe : VERTICAL/ HORIZONTAL
EUT : Industrial Cellular Router	Note : EDGE 1900 / CH 512

Frequency (MHz)	Antenna Polarization	Antenna Terminals leve (dBm)	Substitution Antenna Gain (dBd)	Emission level (dBm)	Limit (dBm)	Margin (dB)
39.59	V	-13.16	-11.29	-24.45	-13.00	-11.45
107.28	V	-12.64	-13.44	-26.08	-13.00	-13.08
110.85	V	-13.44	-13.78	-27.22	-13.00	-14.22
127.69	V	-13.36	-14.15	-27.51	-13.00	-14.51
135.02	V	-14.19	-14.47	-28.66	-13.00	-15.66
827.05	V	-27.74	1.87	-25.87	-13.00	-12.87
74.16	H	-11.54	-16.63	-28.17	-13.00	-15.17
86.13	H	-12.16	-15.27	-27.43	-13.00	-14.43
108.74	H	-12.71	-14.25	-26.96	-13.00	-13.96
127.28	H	-11.97	-14.15	-26.12	-13.00	-13.12
311.95	H	-17.05	-9.74	-26.79	-13.00	-13.79
895.61	H	-24.74	-2.44	-27.18	-13.00	-14.18



Engineer : MATT	Time : 2014-04-08
Site : EMC Lab AC 102	Margin : 6
Limit : FCC_Part22&24	Probe : VERTICAL/ HORIZONTAL
EUT : Industrial Cellular Router	Note : EDGE 1900 / CH 661

Frequency (MHz)	Antenna Polarization	Antenna Terminals level (dBm)	Substitution Antenna Gain (dBd)	Emission level (dBm)	Limit (dBm)	Margin (dB)
39.74	V	-14.92	-11.29	-26.21	-13.00	-13.21
107.16	V	-13.16	-13.44	-26.60	-13.00	-13.60
111.97	V	-12.69	-13.78	-26.47	-13.00	-13.47
128.11	V	-14.19	-14.15	-28.34	-13.00	-15.34
136.34	V	-13.62	-14.47	-28.09	-13.00	-15.09
827.95	V	-27.70	1.87	-25.83	-13.00	-12.83
75.16	H	-10.87	-16.63	-27.50	-13.00	-14.50
86.17	H	-11.49	-15.27	-26.76	-13.00	-13.76
107.80	H	-11.61	-14.25	-25.86	-13.00	-12.86
127.96	H	-12.68	-14.15	-26.83	-13.00	-13.83
310.29	H	-16.17	-9.74	-25.91	-13.00	-12.91
899.52	H	-23.85	-2.18	-26.03	-13.00	-13.03



Engineer : MATT	Time : 2014-04-08
Site : EMC Lab AC 102	Margin : 6
Limit : FCC_Part22&24	Probe : VERTICAL/ HORIZONTAL
EUT : Industrial Cellular Router	Note : EDGE 1900 / CH 810

Frequency (MHz)	Antenna Polarization	Antenna Terminals level (dBm)	Substitution Antenna Gain (dBd)	Emission level (dBm)	Limit (dBm)	Margin (dB)
38.17	V	-15.08	-11.29	-26.37	-13.00	-13.37
107.16	V	-14.16	-13.44	-27.60	-13.00	-14.60
111.87	V	-11.85	-13.78	-25.63	-13.00	-12.63
127.28	V	-12.64	-14.15	-26.79	-13.00	-13.79
136.97	V	-14.57	-14.47	-29.04	-13.00	-16.04
829.24	V	-28.10	1.87	-26.23	-13.00	-13.23
75.08	H	-10.65	-16.63	-27.28	-13.00	-14.28
84.27	H	-10.79	-15.27	-26.06	-13.00	-13.06
107.46	H	-10.90	-14.25	-25.15	-13.00	-12.15
128.30	H	-12.16	-14.15	-26.31	-13.00	-13.31
312.50	H	-15.74	-9.74	-25.48	-13.00	-12.48
897.62	H	-25.28	-2.44	-27.72	-13.00	-14.72



Engineer : MATT	Time : 2014-04-08
Site : EMC Lab AC 102	Margin : 6
Limit : FCC_Part22&24&27	Probe : VERTICAL/ HORIZONTAL
EUT : Industrial Cellular Router	Note : HSUPA 850/ CH 4132

Frequency (MHz)	Antenna Polarization	Antenna Terminals level (dBm)	Substitution Antenna Gain (dBd)	Emission level (dBm)	Limit (dB m)	Margin (dB)
37.51	V	-14.05	-11.01	-25.06	-13.00	-12.06
106.41	V	-11.20	-13.44	-24.64	-13.00	-11.64
109.30	V	-10.96	-13.65	-24.61	-13.00	-11.61
127.05	V	-12.17	-14.15	-26.32	-13.00	-13.32
134.47	V	-12.94	-14.47	-27.41	-13.00	-14.41
827.39	V	-25.26	1.87	-23.39	-13.00	-10.39
74.81	H	-11.06	-16.63	-27.69	-13.00	-14.69
86.28	H	-10.10	-15.27	-25.37	-13.00	-12.37
107.05	H	-13.05	-14.25	-27.30	-13.00	-14.30
128.65	H	-11.54	-14.15	-25.69	-13.00	-12.69
312.14	H	-16.05	-9.74	-25.79	-13.00	-12.79
895.54	H	-22.65	-2.44	-25.09	-13.00	-12.09



Engineer : MATT	Time : 2014-04-08
Site : EMC Lab AC 102	Margin : 6
Limit : FCC_Part22&24&27	Probe : VERTICAL/ HORIZONTAL
EUT : Industrial Cellular Router	Note : HSUPA 850 CH 4183

Frequency (MHz)	Antenna Polarization	Antenna Terminals level (dB m)	Substitution Antenna Gain (dBd)	Emission level (dBm)	Limit (dBm)	Margin (dB)
37.81	V	-14.29	-11.29	-25.58	-13.00	-12.58
101.64	V	-13.36	-11.47	-24.83	-13.00	-11.83
111.51	V	-12.64	-13.78	-26.42	-13.00	-13.42
126.05	V	-12.05	-14.15	-26.20	-13.00	-13.20
136.50	V	-13.97	-14.47	-28.44	-13.00	-15.44
817.06	V	-25.40	1.87	-23.53	-13.00	-10.53
75.67	H	-10.15	-16.63	-26.78	-13.00	-13.78
86.13	H	-11.87	-15.27	-27.14	-13.00	-14.14
107.60	H	-10.88	-14.25	-25.13	-13.00	-12.13
126.81	H	-11.08	-14.15	-25.23	-13.00	-12.23
312.08	H	-13.87	-9.74	-23.61	-13.00	-10.61
896.40	H	-22.41	-2.44	-24.85	-13.00	-11.85





Engineer : MATT	Time : 2014-04-08
Site : EMC Lab AC 102	Margin : 6
Limit : FCC_Part22&24&27	Probe : VERTICAL/ HORIZONTAL
EUT : Industrial Cellular Router	Note: HSUPA 850/ CH 4233

Frequency (MHz)	Antenna Polarization	Antenna Terminals level (dBm)	Substitution Antenna Gain (dBd)	Emission level (dBm)	Limit (dBm)	Margin (dB)
38.40	V	-14.65	-11.29	-25.94	-13.00	-12.94
106.65	V	-11.50	-13.44	-24.94	-13.00	-11.94
111.06	V	-11.00	-13.78	-24.78	-13.00	-11.78
127.48	V	-12.96	-14.15	-27.11	-13.00	-14.11
136.77	V	-11.87	-14.47	-26.34	-13.00	-13.34
828.90	V	-28.11	1.87	-26.24	-13.00	-13.24
75.20	H	-10.65	-16.63	-27.28	-13.00	-14.28
86.29	H	-10.23	-15.27	-25.50	-13.00	-12.50
107.51	H	-9.80	-14.25	-24.05	-13.00	-11.05
128.87	H	-12.01	-14.15	-26.16	-13.00	-13.16
311.04	H	-16.08	-9.74	-25.82	-13.00	-12.82
897.18	H	-23.54	-2.44	-25.98	-13.00	-12.98



Engineer : Matt	Time : 2014-04-08
Site : EMC Lab AC 102	Margin : 6
Limit : FCC_Part22&24&27	Probe : VERTICAL/ HORIZONTAL
EUT : Industrial Cellular Router	Note : HSDPA 850 / CH 4132

Frequency (MHz)	Antenna Polarization	Antenna Terminals level (dBm)	Substitution Antenna Gain (dBd)	Emission level (dBm)	Limit (dBm)	Margin (dB)
36.71	V	-13.50	-11.29	-24.79	-13.00	-11.79
107.41	V	-12.18	-13.44	-25.62	-13.00	-12.62
112.65	V	-14.14	-13.78	-27.92	-13.00	-14.92
128.05	V	-13.07	-14.15	-27.22	-13.00	-14.22
137.19	V	-14.84	-14.47	-29.31	-13.00	-16.31
828.98	V	-26.26	1.87	-24.39	-13.00	-11.39
74.15	H	-11.20	-16.63	-27.83	-13.00	-14.83
85.64	H	-12.59	-15.27	-27.86	-13.00	-14.86
108.97	H	-13.28	-14.25	-27.53	-13.00	-14.53
127.41	H	-12.08	-14.15	-26.23	-13.00	-13.23
312.82	H	-17.97	-9.74	-27.71	-13.00	-14.71
895.05	H	-23.95	-2.44	-26.39	-13.00	-13.39



Engineer : MATT	Time : 2014-04-08
Site : EMC Lab AC 102	Margin : 6
Limit : FCC_Part22&24&27	Probe : VERTICAL/ HORIZONTAL
EUT : Industrial Cellular Router	Note : HSDPA 850 / CH 4183

Frequency (MHz)	Antenna Polarization	Antenna Terminals level (dBm)	Substitution Antenna Gain (dBd)	Emission level (dBm)	Limit (dBm)	Margin (dB)
39.54	V	-14.40	-11.29	-25.69	-13.00	-12.69
107.80	V	-14.01	-13.44	-27.45	-13.00	-14.45
111.08	V	-13.45	-13.78	-27.23	-13.00	-14.23
128.97	V	-14.19	-14.15	-28.34	-13.00	-15.34
137.41	V	-12.65	-14.47	-27.12	-13.00	-14.12
827.96	V	-26.30	1.87	-24.43	-13.00	-11.43
75.85	H	-11.05	-16.63	-27.68	-13.00	-14.68
87.26	H	-12.05	-15.27	-27.32	-13.00	-14.32
107.05	H	-12.74	-14.25	-26.99	-13.00	-13.99
127.90	H	-13.87	-14.15	-28.02	-13.00	-15.02
311.18	H	-17.09	-9.74	-26.83	-13.00	-13.83
900.02	H	-22.97	-2.18	-25.15	-13.00	-12.15



Engineer : MATT	Time : 2014-04-08
Site : EMC Lab AC 102	Margin : 6
Limit : FCC_Part22&24&27	Probe : VERTICAL/ HORIZONTAL
EUT : Industrial Cellular Router	Note : HSDPA 850 / CH 4233

Frequency (MHz)	Antenna Polarization	Antenna Terminals level (dBm)	Substitution Antenna Gain (dBd)	Emission level (dBm)	Limit (dBm)	Margin (dB)
38.05	V	-15.64	-11.29	-26.93	-13.00	-13.93
107.80	V	-14.10	-13.44	-27.54	-13.00	-14.54
118.80	V	-12.41	-13.78	-26.19	-13.00	-13.19
128.06	V	-13.98	-14.15	-28.13	-13.00	-15.13
137.57	V	-14.05	-14.47	-28.52	-13.00	-15.52
831.20	V	-26.97	1.87	-25.10	-13.00	-12.10
75.15	H	-10.04	-16.63	-26.67	-13.00	-13.67
84.87	H	-10.41	-15.27	-25.68	-13.00	-12.68
108.09	H	-11.96	-14.25	-26.21	-13.00	-13.21
127.54	H	-12.74	-14.15	-26.89	-13.00	-13.89
313.02	H	-16.05	-9.74	-25.79	-13.00	-12.79
898.80	H	-24.96	-2.44	-27.40	-13.00	-14.40



Engineer : MATT	Time : 2014-04-08
Site : EMC Lab AC 102	Margin : 6
Limit : FCC_Part22&24&27	Probe : VERTICAL/ HORIZONTAL
EUT : Industrial Cellular Router	Note : HSUPA 1900/ CH 9262

Frequency (MHz)	Antenna Polarization	Antenna Terminals level (dBm)	Substitution Antenna Gain (dBd)	Emission level (dBm)	Limit (dBm)	Margin (dB)
39.11	V	-13.46	-11.29	-24.75	-13.00	-11.75
107.19	V	-12.44	-13.44	-25.88	-13.00	-12.88
110.03	V	-13.56	-13.78	-27.34	-13.00	-14.34
127.76	V	-13.44	-14.15	-27.59	-13.00	-14.59
135.98	V	-14.11	-14.47	-28.58	-13.00	-15.58
827.98	V	-27.12	1.87	-25.25	-13.00	-12.25
74.11	H	-11.22	-16.63	-27.85	-13.00	-14.85
85.79	H	-12.12	-15.27	-27.39	-13.00	-14.39
108.33	H	-12.78	-14.25	-27.03	-13.00	-14.03
127.12	H	-11.49	-14.15	-25.64	-13.00	-12.64
311.23	H	-17.33	-9.74	-27.07	-13.00	-14.07
895.21	H	-24.04	-2.44	-26.48	-13.00	-13.48



Engineer : MATT	Time : 2014-04-08
Site : EMC Lab AC 102	Margin : 6
Limit : FCC_Part22&24&27	Probe : VERTICAL/ HORIZONTAL
EUT : Industrial Cellular Router	Note : HSUPA 1900/ CH 9400

Frequency (MHz)	Antenna Polarization	Antenna Terminals leve (dBm)	Substitution Antenna Gain (dBd)	Emission level (dBm)	Limit (dBm)	Margin (dB)
39.27	V	-14.22	-11.29	-25.51	-13.00	-12.51
106.98	V	-13.45	-13.44	-26.89	-13.00	-13.89
111.29	V	-12.87	-13.78	-26.65	-13.00	-13.65
127.98	V	-14.12	-14.15	-28.27	-13.00	-15.27
136.00	V	-13.09	-14.47	-27.56	-13.00	-14.56
827.19	V	-27.12	1.87	-25.25	-13.00	-12.25
75.32	H	-10.29	-16.63	-26.92	-13.00	-13.92
86.19	H	-11.98	-15.27	-27.25	-13.00	-14.25
107.28	H	-11.48	-14.25	-25.73	-13.00	-12.73
127.34	H	-12.86	-14.15	-27.01	-13.00	-14.01
310.92	H	-16.27	-9.74	-26.01	-13.00	-13.01
899.25	H	-23.02	-2.18	-25.20	-13.00	-12.20



Engineer : MATT	Time : 2014-04-08
Site : EMC Lab AC 102	Margin : 6
Limit : FCC_Part22&24&27	Probe : VERTICAL/ HORIZONTAL
EUT : Industrial Cellular Router	Note : HSUPA 1900/ CH 9538

Frequency (MHz)	Antenna Polarization	Antenna Terminals level (dBm)	Substitution Antenna Gain (dBd)	Emission level (dBm)	Limit (dBm)	Margin (dB)
38.27	V	-14.28	-11.29	-25.57	-13.00	-12.57
107.22	V	-13.96	-13.44	-27.40	-13.00	-14.40
111.76	V	-11.24	-13.78	-25.02	-13.00	-12.02
127.76	V	-12.10	-14.15	-26.25	-13.00	-13.25
136.89	V	-13.87	-14.47	-28.34	-13.00	-15.34
829.98	V	-28.12	1.87	-26.25	-13.00	-13.25
75.12	H	-10.46	-16.63	-27.09	-13.00	-14.09
84.22	H	-10.23	-15.27	-25.50	-13.00	-12.50
107.28	H	-10.38	-14.25	-24.63	-13.00	-11.63
128.10	H	-11.98	-14.15	-26.13	-13.00	-13.13
312.11	H	-15.77	-9.74	-25.51	-13.00	-12.51
897.26	H	-25.28	-2.44	-27.72	-13.00	-14.72



Engineer : MATT	Time : 2014-04-08
Site : EMC Lab AC 102	Margin : 6
Limit : FCC_Part22&24&27	Probe : VERTICAL/ HORIZONTAL
EUT : Industrial Cellular Router	Note : HSDPA 1900 / CH 9262

Frequency (MHz)	Antenna Polarization	Antenna Terminals level (dBm)	Substitution Antenna Gain (dBd)	Emission level (dBm)	Limit (dBm)	Margin (dB)
37.52	V	-14.51	-11.29	-25.80	-13.00	-12.80
107.41	V	-12.05	-13.44	-25.49	-13.00	-12.49
110.25	V	-11.59	-13.78	-25.37	-13.00	-12.37
128.24	V	-13.69	-14.15	-27.84	-13.00	-14.84
134.63	V	-12.78	-14.47	-27.25	-13.00	-14.25
827.96	V	-24.15	1.87	-22.28	-13.00	-9.28
75.01	H	-10.96	-16.63	-27.59	-13.00	-14.59
86.63	H	-10.65	-15.27	-25.92	-13.00	-12.92
107.84	H	-14.05	-14.25	-28.30	-13.00	-15.30
128.63	H	-12.81	-14.15	-26.96	-13.00	-13.96
313.07	H	-17.48	-9.74	-27.22	-13.00	-14.22
896.62	H	-21.08	-2.44	-23.52	-13.00	-10.52





Engineer : MATT	Time : 2014-04-08
Site : EMC Lab AC 102	Margin : 6
Limit : FCC_Part22&24&27	Probe : VERTICAL/ HORIZONTAL
EUT : Industrial Cellular Router	Note : HSDPA 1900 / CH 9400

Frequency (MHz)	Antenna Polarization	Antenna Terminals level (dBm)	Substitution Antenna Gain (dBd)	Emission level (dBm)	Limit (dBm)	Margin (dB)
37.51	V	-13.63	-11.29	-24.92	-13.00	-11.92
101.59	V	-14.15	-11.47	-25.62	-13.00	-12.62
111.57	V	-13.26	-13.78	-27.04	-13.00	-14.04
127.59	V	-12.87	-14.15	-27.02	-13.00	-14.02
137.51	V	-13.84	-14.47	-28.31	-13.00	-15.31
818.63	V	-24.57	1.87	-22.70	-13.00	-9.70
75.96	H	-10.62	-16.63	-27.25	-13.00	-14.25
87.51	H	-11.52	-15.27	-26.79	-13.00	-13.79
107.89	H	-10.57	-14.25	-24.82	-13.00	-11.82
127.62	H	-12.59	-14.15	-26.74	-13.00	-13.74
312.33	H	-14.51	-9.74	-24.25	-13.00	-11.25
897.00	H	-21.52	-2.44	-23.96	-13.00	-10.96



Engineer : MATT	Time : 2014-04-08
Site : EMC Lab AC 102	Margin : 6
Limit : FCC_Part22&24&27	Probe : VERTICAL/ HORIZONTAL
EUT : Industrial Cellular Router	Note : HSDPA 1900 / CH 9538

Frequency (MHz)	Antenna Polarization	Antenna Terminals level (dBm)	Substitution Antenna Gain (dBd)	Emission level (dBm)	Limit (dBm)	Margin (dB)
38.62	V	-14.52	-11.29	-25.81	-13.00	-12.81
106.52	V	-12.14	-11.47	-23.61	-13.00	-10.61
112.21	V	-13.62	-13.78	-27.40	-13.00	-14.40
127.96	V	-12.57	-14.15	-26.72	-13.00	-13.72
136.89	V	-13.25	-14.47	-27.72	-13.00	-14.72
829.67	V	-27.14	1.87	-25.27	-13.00	-12.27
75.96	H	-11.24	-16.63	-27.87	-13.00	-14.87
86.94	H	-11.52	-15.27	-26.79	-13.00	-13.79
107.84	H	-11.09	-14.25	-25.34	-13.00	-12.34
129.69	H	-12.56	-14.15	-26.71	-13.00	-13.71
312.51	H	-16.51	-9.74	-26.25	-13.00	-13.25
897.48	H	-22.15	-2.44	-24.59	-13.00	-11.59



Engineer : MATT	Time : 2014-04-08
Site : EMC Lab AC 102	Margin : 6
Limit : FCC_Part22&24&27	Probe : VERTICAL/ HORIZONTAL
EUT : Industrial Cellular Router	Note :HAUPA 1700/ CH 1312

Frequency (MHz)	Antenna Polarization	Antenna Terminals level (dB m)	Substitution Antenna Gain (dB d)	Emission level (dBm)	Limit (dBm)	Margin (dB)
37.19	V	-13.40	-11.29	-24.69	-13.00	-11.69
109.96	V	-12.84	-13.44	-26.28	-13.00	-13.28
111.06	V	-13.96	-13.78	-27.74	-13.00	-14.74
127.17	V	-14.01	-14.15	-28.16	-13.00	-15.16
136.65	V	-14.64	-14.47	-29.11	-13.00	-16.11
825.98	V	-28.29	1.87	-26.42	-13.00	-13.42
75.51	H	-12.50	-16.63	-29.13	-13.00	-16.13
85.95	H	-12.65	-15.27	-27.92	-13.00	-14.92
109.44	H	-12.70	-14.25	-26.95	-13.00	-13.95
125.97	H	-12.68	-14.15	-26.83	-13.00	-13.83
312.91	H	-16.49	-9.74	-26.23	-13.00	-13.23
896.41	H	-24.02	-2.44	-26.46	-13.00	-13.46



Engineer : MATT	Time : 2014-04-08
Site : EMC Lab AC 102	Margin : 6
Limit : FCC_Part22&24&27	Probe : VERTICAL/ HORIZONTAL
EUT : Industrial Cellular Router	Note : HAUPA 1700/ CH 1413

Frequency (MHz)	Antenna Polarization	Antenna Terminals leve (dBm)	Substitution Antenna Gain (dBd)	Emission level (dBm)	Limit (dBm)	Margin (dB)
38.27	V	-13.98	-11.29	-25.27	-13.00	-12.27
109.19	V	-13.24	-13.44	-26.68	-13.00	-13.68
110.98	V	-12.88	-13.78	-26.66	-13.00	-13.66
128.05	V	-14.97	-14.15	-29.12	-13.00	-16.12
137.62	V	-13.08	-14.47	-27.55	-13.00	-14.55
830.87	V	-28.50	1.87	-26.63	-13.00	-13.63
74.19	H	-11.49	-16.63	-28.12	-13.00	-15.12
87.95	H	-11.97	-15.27	-27.24	-13.00	-14.24
109.16	H	-11.71	-14.25	-25.96	-13.00	-12.96
127.49	H	-12.68	-14.15	-26.83	-13.00	-13.83
312.97	H	-16.41	-9.74	-26.15	-13.00	-13.15
898.18	H	-23.65	-2.18	-25.83	-13.00	-12.83



Engineer : MATT	Time : 2014-04-08
Site : EMC Lab AC 102	Margin : 6
Limit : FCC_Part22&24&27	Probe : VERTICAL/ HORIZONTAL
EUT : Industrial Cellular Router	Note : HAUPA 1700/ CH 1513

Frequency (MHz)	Antenna Polarization	Antenna Terminals level (dBm)	Substitution Antenna Gain (dBd)	Emission level (dBm)	Limit (dBm)	Margin (dB)
39.64	V	-13.57	-11.29	-24.86	-13.00	-11.86
108.05	V	-13.74	-13.44	-27.18	-13.00	-14.18
112.55	V	-12.54	-13.78	-26.32	-13.00	-13.32
127.97	V	-12.18	-14.15	-26.33	-13.00	-13.33
137.19	V	-13.14	-14.47	-27.61	-13.00	-14.61
831.40	V	-28.60	1.87	-26.73	-13.00	-13.73
72.40	H	-11.27	-16.63	-27.90	-13.00	-14.90
84.73	H	-10.77	-15.27	-26.04	-13.00	-13.04
109.49	H	-10.51	-14.25	-24.76	-13.00	-11.76
128.60	H	-11.87	-14.15	-26.02	-13.00	-13.02
315.18	H	-14.67	-9.74	-24.41	-13.00	-11.41
895.50	H	-25.56	-2.44	-28.00	-13.00	-15.00



Engineer : MATT	Time : 2014-04-08
Site : EMC Lab AC 102	Margin : 6
Limit : FCC_Part22&24&27	Probe : VERTICAL/ HORIZONTAL
EUT : Industrial Cellular Router	Note : HSDPA 1700 /CH 1312

Frequency (MHz)	Antenna Polarization	Antenna Terminals level (dBm)	Substitution Antenna Gain (dBd)	Emission level (dBm)	Limit (dBm)	Margin (dB)
35.67	V	-14.23	-11.01	-25.24	-13.00	-12.24
105.23	V	-11.56	-13.44	-25.00	-13.00	-12.00
110.56	V	-10.56	-13.65	-24.21	-13.00	-11.21
128.56	V	-12.46	-14.15	-26.61	-13.00	-13.61
134.67	V	-12.95	-14.47	-27.42	-13.00	-14.42
826.35	V	-25.22	1.87	-23.35	-13.00	-10.35
78.34	H	-10.66	-16.63	-27.29	-13.00	-14.29
85.02	H	-10.23	-15.27	-25.50	-13.00	-12.50
104.51	H	-13.56	-14.25	-27.81	-13.00	-14.81
130.59	H	-12.46	-14.15	-26.61	-13.00	-13.61
315.76	H	-12.68	-9.74	-22.42	-13.00	-9.42
892.44	H	-23.66	-2.44	-26.10	-13.00	-13.10



Engineer : MATT	Time : 2014-04-08
Site : EMC Lab AC 102	Margin : 6
Limit : FCC_Part22&24&27	Probe : VERTICAL/ HORIZONTAL
EUT : Industrial Cellular Router	Note : HSDPA 1700 /CH 1413

Frequency (MHz)	Antenna Polarization	Antenna Terminals level (dBm)	Substitution Antenna Gain (dBd)	Emission level (dBm)	Limit (dBm)	Margin (dB)
35.31	V	-14.45	-11.29	-25.74	-13.00	-12.74
100.67	V	-13.56	-11.47	-25.03	-13.00	-12.03
113.57	V	-12.67	-13.78	-26.45	-13.00	-13.45
128.67	V	-12.56	-14.15	-26.71	-13.00	-13.71
140.66	V	-13.15	-14.47	-27.62	-13.00	-14.62
816.46	V	-25.65	1.87	-23.78	-13.00	-10.78
76.21	H	-11.92	-16.63	-28.55	-13.00	-15.55
85.67	H	-11.56	-15.27	-26.83	-13.00	-13.83
108.44	H	-10.73	-14.25	-24.98	-13.00	-11.98
126.97	H	-11.85	-14.15	-26.00	-13.00	-13.00
315.67	H	-13.66	-9.74	-23.40	-13.00	-10.40
895.11	H	-22.94	-2.44	-25.38	-13.00	-12.38



Engineer : MATT	Time : 2014-04-08
Site : EMC Lab AC 102	Margin : 6
Limit : FCC_Part22&24&27	Probe : VERTICAL/ HORIZONTAL
EUT : Industrial Cellular Router	Note : HSDPA 1700 /CH 1513

Frequency (MHz)	Antenna Polarization	Antenna Terminals leve (dBm)	Substitution Antenna Gain (dBd)	Emission level (dBm)	Limit (dBm)	Margin (dB)
36.55	V	-13.56	-11.29	-24.85	-13.00	-11.85
108.42	V	-12.56	-13.44	-26.00	-13.00	-13.00
112.56	V	-11.89	-13.78	-25.67	-13.00	-12.67
127.67	V	-12.57	-14.15	-26.72	-13.00	-13.72
135.79	V	-14.10	-14.47	-28.57	-13.00	-15.57
829.45	V	-25.67	1.87	-23.80	-13.00	-10.80
75.27	H	-10.66	-16.63	-27.29	-13.00	-14.29
81.47	H	-10.64	-15.27	-25.91	-13.00	-12.91
108.67	H	-10.05	-14.25	-24.30	-13.00	-11.30
134.78	H	-11.62	-14.15	-25.77	-13.00	-12.77
314.50	H	-15.86	-9.74	-25.60	-13.00	-12.60
899.55	H	-23.55	-2.44	-25.99	-13.00	-12.99





Above 1G:

Engineer : MATT	Time : 2014-04-08
Site : EMC Lab AC 102	Margin : 6
Limit : FCC_Part22&24	Probe : VERTICAL/ HORIZONTAL
EUT : Industrial Cellular Router	Note : EDGE 850 / CH 128

Frequency (MHz)	Antenna Polarization	Antenna Terminals level (dBm)	Substitution Antenna Gain (dBi)	Emission level (dBm)	Limit (dBm)	Margin (dB)
1649.61	V	-26.13	1.29	-24.84	-13.00	-11.84
1649.03	H	-28.41	1.31	-27.10	-13.00	-14.10

Note :The other harmonic spurious emissions are under limit 20dB more, so the results were not shown in the table.



Engineer : MATT	Time : 2014-04-08
Site : EMC Lab AC 102	Margin : 6
Limit : FCC_Part22&24	Probe : VERTICAL/ HORIZONTAL
EUT : Industrial Cellular Router	Note : EDGE 850 / CH 190

Frequency (MHz)	Antenna Polarization	Antenna Terminals level (dBm)	Substitution Antenna Gain (dBi)	Emission level (dBm)	Limit (dBm)	Margin (dB)
1674.10	V	-28.85	1.33	-27.52	-13.00	-14.52
1675.81	H	-29.14	1.36	-27.78	-13.00	-14.78

Note :The other harmonic spurious emissions are under limit 20dB more,  
so the results were not shown in the table.



Engineer : MATT	Time : 2014-04-08
Site : EMC Lab AC 102	Margin : 6
Limit : FCC_Part22&24	Probe : VERTICAL/ HORIZONTAL
EUT : Industrial Cellular Router	Note : EDGE 850 / CH 251

Frequency (MHz)	Antenna Polarization	Antenna Terminals level (dBm)	Substitution Antenna Gain (dBi)	Emission level (dBm)	Limit (dBm)	Margin (dB)
1699.01	V	-27.16	1.38	-25.78	-13.00	-12.78
1698.73	H	-29.56	1.41	-28.15	-13.00	-15.15

Note :The other harmonic spurious emissions are under limit 20dB more,  
so the results were not shown in the table.



Engineer : MATT	Time : 2014-04-08
Site : EMC Lab AC 102	Margin : 6
Limit : FCC_Part22&24	Probe : VERTICAL/ HORIZONTAL
EUT : Industrial Cellular Router	Note : EDGE 1900 / CH 512

Frequency (MHz)	Antenna Polarization	Antenna Terminals leve (dBm)	Substitution Antenna Gain (dBi)	Emission level (dBm)	Limit (dBm)	Margin (dB)
3700.50	V	-32.54	3.41	-29.13	-13.00	-16.13
3700.74	H	-32.15	3.52	-28.63	-13.00	-15.63

Note :The other harmonic spurious emissions are under limit 20dB more,  
so the results were not shown in the table.



Engineer : MATT	Time : 2014-04-08
Site : EMC Lab AC 102	Margin : 6
Limit : FCC_Part22&24	Probe : VERTICAL/ HORIZONTAL
EUT : Industrial Cellular Router	Note : EDGE 1900 / CH 661

Frequency (MHz)	Antenna Polarization	Antenna Terminals leve (dBm)	Substitution Antenna Gain (dBi)	Emission level (dBm)	Limit (dBm)	Margin (dB)
3760.16	V	-31.74	3.48	-28.26	-13.00	-15.26
3760.52	H	-33.67	3.56	-30.11	-13.00	-17.11

Note :The other harmonic spurious emissions are under limit 20dB more,  
so the results were not shown in the table.



Engineer : MATT	Time : 2014-04-08
Site : EMC Lab AC 102	Margin : 6
Limit : FCC_Part22&24	Probe : VERTICAL/ HORIZONTAL
EUT : Industrial Cellular Router	Note : EDGE 1900 / CH 810

Frequency (MHz)	Antenna Polarization	Antenna Terminals leve (dBm)	Substitution Antenna Gain (dBi)	Emission level (dBm)	Limit (dBm)	Margin (dB)
3819.72	V	-30.87	3.57	-27.30	-13.00	-14.30
3820.16	H	-31.96	3.64	-28.32	-13.00	-15.32

Note :The other harmonic spurious emissions are under limit 20dB more,  
so the results were not shown in the table.



Engineer : MATT	Time : 2014-04-08
Site : EMC Lab AC 102	Margin : 6
Limit : FCC_Part22&24&27	Probe : VERTICAL/ HORIZONTAL
EUT : Industrial Cellular Router	Note : HSUPA 850 / CH 4132

Frequency (MHz)	Antenna Polarization	Antenna Terminals level (dBm)	Substitution Antenna Gain (dBi)	Emission level (dBm)	Limit (dBm)	Margin (dB)
3199.15	V	-48.17	1.29	-46.88	-13.00	-33.88
3201.44	H	-49.17	1.31	-47.86	-13.00	-34.86

Note :The other harmonic spurious emissions are under limit 20dB more, so the results were not shown in the table.



Engineer : MATT	Time : 2014-04-08
Site : EMC Lab AC 102	Margin : 6
Limit : FCC_Part22&24&27	Probe : VERTICAL/ HORIZONTAL
EUT : Industrial Cellular Router	Note : HSUPA 850 / CH 4183

Frequency (MHz)	Antenna Polarization	Antenna Terminals level (dBm)	Substitution Antenna Gain (dBi)	Emission level (dBm)	Limit (dBm)	Margin (dB)
3199.64	V	-47.64	1.29	-46.35	-13.00	-33.35
3201.96	H	-50.16	1.31	-48.85	-13.00	-35.85

Note :The other harmonic spurious emissions are under limit 20dB more, so the results were not shown in the table.





Engineer : MATT	Time : 2014-04-08
Site : EMC Lab AC 102	Margin : 6
Limit : FCC_Part22&24&27	Probe : VERTICAL/ HORIZONTAL
EUT : Industrial Cellular Router	Note : HSUPA 850 / CH 4233

Frequency (MHz)	Antenna Polarization	Antenna Terminals leve (dBm)	Substitution Antenna Gain (dBi)	Emission level (dBm)	Limit (dBm)	Margin (dB)
3199.84	V	-48.62	1.29	-47.33	-13.00	-34.33
3201.05	H	-49.99	1.31	-48.68	-13.00	-35.68

Note :The other harmonic spurious emissions are under limit 20dB more,  
so the results were not shown in the table.



Engineer : MATT	Time : 2014-04-08
Site : EMC Lab AC 102	Margin : 6
Limit : FCC_Part22&24&27	Probe : VERTICAL/ HORIZONTAL
EUT : Industrial Cellular Router	Note : HSDPA 850 / CH 4132

Frequency (MHz)	Antenna Polarization	Antenna Terminals level (dBm)	Substitution Antenna Gain (dBi)	Emission level (dBm)	Limit (dBm)	Margin (dB)
3199.14	V	-47.64	1.29	-46.35	-13.00	-33.35
3200.74	H	-49.02	1.31	-47.71	-13.00	-34.71

Note :The other harmonic spurious emissions are under limit 20dB more, so the results were not shown in the table.



Engineer : MATT	Time : 2014-01-29
Site : EMC Lab AC 102	Margin : 6
Limit : FCC_Part22&24&27	Probe : VERTICAL/ HORIZONTAL
EUT : Industrial Cellular Router	Note : HSDPA 850 / CH 4183

Frequency (MHz)	Antenna Polarization	Antenna Terminals leve (dBm)	Substitution Antenna Gain (dBi)	Emission level (dBm)	Limit (dBm)	Margin (dB)
3190.18	V	-47.40	1.29	-46.11	-13.00	-33.11
3200.94	H	-48.55	1.31	-47.24	-13.00	-34.24

Note :The other harmonic spurious emissions are under limit 20dB more,  
so the results were not shown in the table.



Engineer : MATT	Time : 2014-04-08
Site : EMC Lab AC 102	Margin : 6
Limit : FCC_Part22&24&27	Probe : VERTICAL/ HORIZONTAL
EUT : Industrial Cellular Router	Note : HSDPA 850 / CH 4233

Frequency (MHz)	Antenna Polarization	Antenna Terminals leve (dBm)	Substitution Antenna Gain (dBi)	Emission level (dBm)	Limit (dBm)	Margin (dB)
3201.18	V	-46.45	1.29	-45.16	-13.00	-32.16
3201.27	H	-49.75	1.31	-48.44	-13.00	-35.44

Note :The other harmonic spurious emissions are under limit 20dB more,  
so the results were not shown in the table.



Engineer : MATT	Time : 2014-04-08
Site : EMC Lab AC 102	Margin : 6
Limit : FCC_Part22&24&27	Probe : VERTICAL/ HORIZONTAL
EUT : Industrial Cellular Router	Note : HSUPA 1900 / CH 9262

Frequency (MHz)	Antenna Polarization	Antenna Terminals level (dBm)	Substitution Antenna Gain (dBi)	Emission level (dBm)	Limit (dBm)	Margin (dB)
3200.59	V	-48.62	1.29	-47.33	-13.00	-34.33
3201.47	H	-49.96	1.31	-48.65	-13.00	-35.65

Note :The other harmonic spurious emissions are under limit 20dB more, so the results were not shown in the table.



Engineer : MATT	Time : 2014-04-08
Site : EMC Lab AC 102	Margin : 6
Limit : FCC_Part22&24&27	Probe : VERTICAL/ HORIZONTAL
EUT : Industrial Cellular Router	Note : HSUPA 1900 / CH 9400

Frequency (MHz)	Antenna Polarization	Antenna Terminals level (dBm)	Substitution Antenna Gain (dBi)	Emission level (dBm)	Limit (dBm)	Margin (dB)
3196.25	V	-49.06	1.29	-47.77	-13.00	-34.77
3201.56	H	-50.42	1.31	-49.11	-13.00	-36.11

Note :The other harmonic spurious emissions are under limit 20dB more,  
so the results were not shown in the table.



Engineer : MATT	Time : 2014-04-08
Site : EMC Lab AC 102	Margin : 6
Limit : FCC_Part22&24&27	Probe : VERTICAL/ HORIZONTAL
EUT : Industrial Cellular Router	Note : HSUPA 1900 / CH 9538

Frequency (MHz)	Antenna Polarization	Antenna Terminals level (dBm)	Substitution Antenna Gain (dBi)	Emission level (dBm)	Limit (dBm)	Margin (dB)
3189.63	V	-48.96	1.29	-47.67	-13.00	-34.67
3203.51	H	-51.42	1.31	-50.11	-13.00	-37.11

Note :The other harmonic spurious emissions are under limit 20dB more,  
so the results were not shown in the table.



Engineer : MATT	Time : 2014-04-08
Site : EMC Lab AC 102	Margin : 6
Limit : FCC_Part22&24&27	Probe : VERTICAL/ HORIZONTAL
EUT : Industrial Cellular Router	Note : HSDPA 1900 / CH 9262

Frequency (MHz)	Antenna Polarization	Antenna Terminals level (dBm)	Substitution Antenna Gain (dBi)	Emission level (dBm)	Limit (dBm)	Margin (dB)
3197.48	V	-47.96	1.29	-46.67	-13.00	-33.67
3202.59	H	-48.59	1.31	-47.28	-13.00	-34.28

Note :The other harmonic spurious emissions are under limit 20dB more,  
so the results were not shown in the table.





Engineer : MATT	Time : 2014-04-08
Site : EMC Lab AC 102	Margin : 6
Limit : FCC_Part22&24&27	Probe : VERTICAL/ HORIZONTAL
EUT : Industrial Cellular Router	Note : HSDPA 1900 / CH 9400

Frequency (MHz)	Antenna Polarization	Antenna Terminals level (dBm)	Substitution Antenna Gain (dBi)	Emission level (dBm)	Limit (dBm)	Margin (dB)
3197.85	V	-48.51	1.29	-47.22	-13.00	-34.22
3202.66	H	-49.89	1.31	-48.58	-13.00	-35.58

Note :The other harmonic spurious emissions are under limit 20dB more,  
so the results were not shown in the table.



Engineer : MATT	Time : 2014-04-08
Site : EMC Lab AC 102	Margin : 6
Limit : FCC_Part22&24&27	Probe : VERTICAL/ HORIZONTAL
EUT : Industrial Cellular Router	Note : HSDPA 1900 / CH 9538

Frequency (MHz)	Antenna Polarization	Antenna Terminals level (dBm)	Substitution Antenna Gain (dBi)	Emission level (dBm)	Limit (dBm)	Margin (dB)
3198.96	V	-48.99	1.29	-47.70	-13.00	-34.70
3202.51	H	-49.98	1.31	-48.67	-13.00	-35.67

Note :The other harmonic spurious emissions are under limit 20dB more, so the results were not shown in the table.



Engineer : MATT	Time : 2014-04-08
Site : EMC Lab AC 102	Margin : 6
Limit : FCC_Part22&24&27	Probe : VERTICAL/ HORIZONTAL
EUT : Industrial Cellular Router	Note : HSUPA 1700/CH 1312

Frequency (MHz)	Antenna Polarization	Antenna Terminals level (dBm)	Substitution Antenna Gain (dBd)	Emission level (dBm)	Limit (dBm)	Margin (dB)
3190.05	V	-46.15	1.29	-44.86	-13.00	-31.86
3198.65	H	-48.40	1.31	-47.09	-13.00	-34.09

Note :The other harmonic spurious emissions are under limit 20dB more,  
so the results were not shown in the table.



Engineer : MATT	Time : 2014-04-08
Site : EMC Lab AC 102	Margin : 6
Limit : FCC_Part22&24&27	Probe : VERTICAL/ HORIZONTAL
EUT : Industrial Cellular Router	Note : HSUPA 1700/CH 1413

Frequency (MHz)	Antenna Polarization	Antenna Terminals level (dBm)	Substitution Antenna Gain (dBd)	Emission level (dBm)	Limit (dBm)	Margin (dB)
3199.50	V	-47.95	1.29	-46.66	-13.00	-33.66
3203.14	H	-51.05	1.31	-49.74	-13.00	-36.74

Note :The other harmonic spurious emissions are under limit 20dB more,  
so the results were not shown in the table.



Engineer : MATT	Time : 2014-04-08
Site : EMC Lab AC 102	Margin : 6
Limit : FCC_Part22&24&27	Probe : VERTICAL/ HORIZONTAL
EUT : Industrial Cellular Router	Note : HSUPA 1700/CH 1513

Frequency (MHz)	Antenna Polarization	Antenna Terminals level (dBm)	Substitution Antenna Gain (dBd)	Emission level (dBm)	Limit (dBm)	Margin (dB)
3202.95	V	-43.67	1.29	-42.38	-13.00	-29.38
3199.15	H	-44.46	1.31	-43.15	-13.00	-30.15

Note :The other harmonic spurious emissions are under limit 20dB more, so the results were not shown in the table.



Engineer : MATT	Time : 2014-04-08
Site : EMC Lab AC 102	Margin : 6
Limit : FCC_Part22&24&27	Probe : VERTICAL/ HORIZONTAL
EUT : Industrial Cellular Router	Note :HSDPA 1700/ CH 1312

Frequency (MHz)	Antenna Polarization	Antenna Terminals level (dBm)	Substitution Antenna Gain (dBd)	Emission level (dBm)	Limit (dBm)	Margin (dB)
3203.45	V	-45.56	1.29	-44.27	-13.00	-31.27
3200.57	H	-49.62	1.31	-48.31	-13.00	-35.31

Note :The other harmonic spurious emissions are under limit 20dB more,  
so the results were not shown in the table.



Engineer : MATT	Time : 2014-04-08
Site : EMC Lab AC 102	Margin : 6
Limit : FCC_Part22&24&27	Probe : VERTICAL/ HORIZONTAL
EUT : Industrial Cellular Router	Note : HSDPA 1700/ CH 1413

Frequency (MHz)	Antenna Polarization	Antenna Terminals leve (dBm)	Substitution Antenna Gain (dBd)	Emission level (dBm)	Limit (dBm)	Margin (dB)
3196.21	V	-46.79	1.29	-45.50	-13.00	-32.50
3198.23	H	-49.66	1.31	-48.35	-13.00	-35.35

Note :The other harmonic spurious emissions are under limit 20dB more,  
so the results were not shown in the table.



Engineer : MATT	Time : 2014-04-08
Site : EMC Lab AC 102	Margin : 6
Limit : FCC_Part22&24&27	Probe : VERTICAL/ HORIZONTAL
EUT : Industrial Cellular Router	Note : HSDPA 1700/ CH 1513

Frequency (MHz)	Antenna Polarization	Antenna Terminals level (dBm)	Substitution Antenna Gain (dBd)	Emission level (dBm)	Limit (dBm)	Margin (dB)
3194.56	V	-45.67	1.29	-44.38	-13.00	-31.38
3202.45	H	-48.12	1.31	-46.81	-13.00	-33.81

Note :The other harmonic spurious emissions are under limit 20dB more,  
so the results were not shown in the table.





## 5. Occupied Bandwidth

### 5.1. Test Limit

According to §FCC 2.1049.

### 5.2. Test Procedures

The EUT's output RF connector was connected with a short cable to the spectrum analyzer, RBW was set to 1% to 5% of emission BW, VBW is set to 3 times the RBW, -26dBc display line was placed on the screen (or 99% bandwidth), the occupied bandwidth is the delta frequency between the two points where the display line intersects the signal trace.

### 5.3. Test Setup Layout

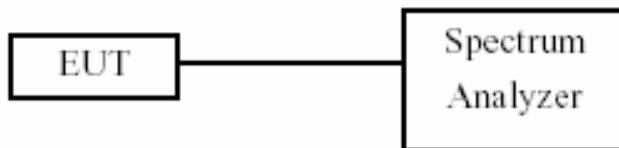

### 5.4. Measurement Equipment

Instrument/Ancillary	Model No.	Manufacturer	Serial No.	Calibration Date	Valid Date
Spectrum Analyzer	FSP40	R&S	100324	2014.03.10	2015.03.09
Temperature/ Humidity Meter	Zhicheng	ZC1-11	CEP-TH-002	2014.03.10	2015.03.09



5.5. Test Result and Data

Test Item	Occupied Bandwidth
Test Mode	EDGE 850
Test Date	2014-04-08

Channel No.	Frequency (MHz)	Measurement Level (kHz)
128	824.2	321.779
190	836.6	309.115
251	848.8	321.124

Channel 128

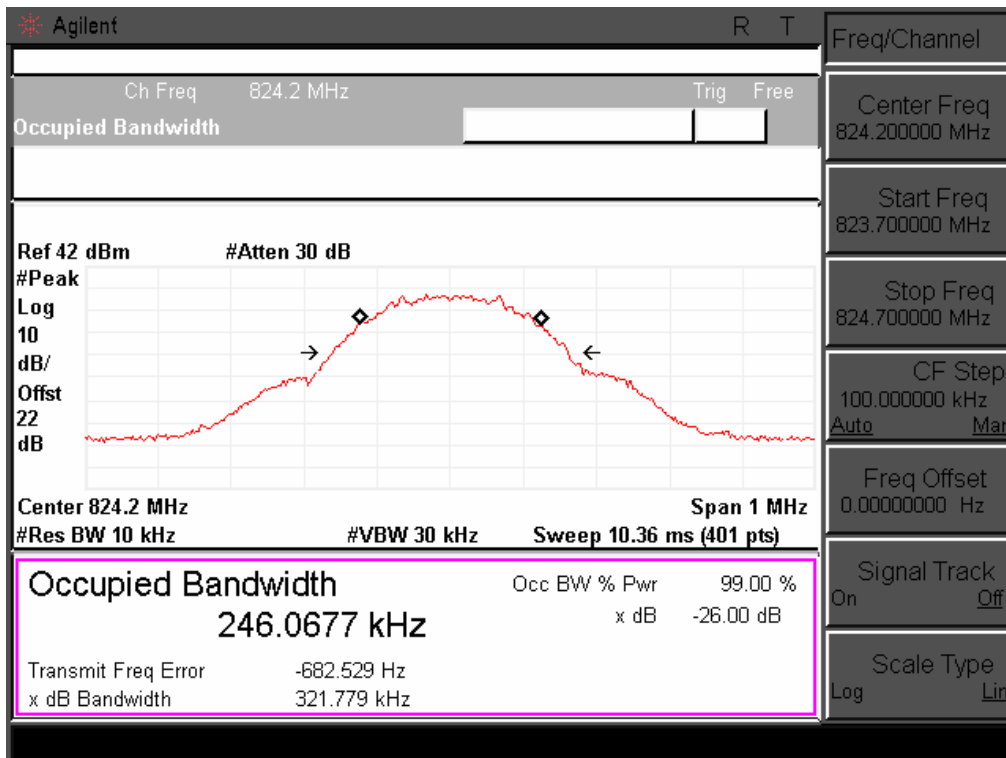



Channel 190

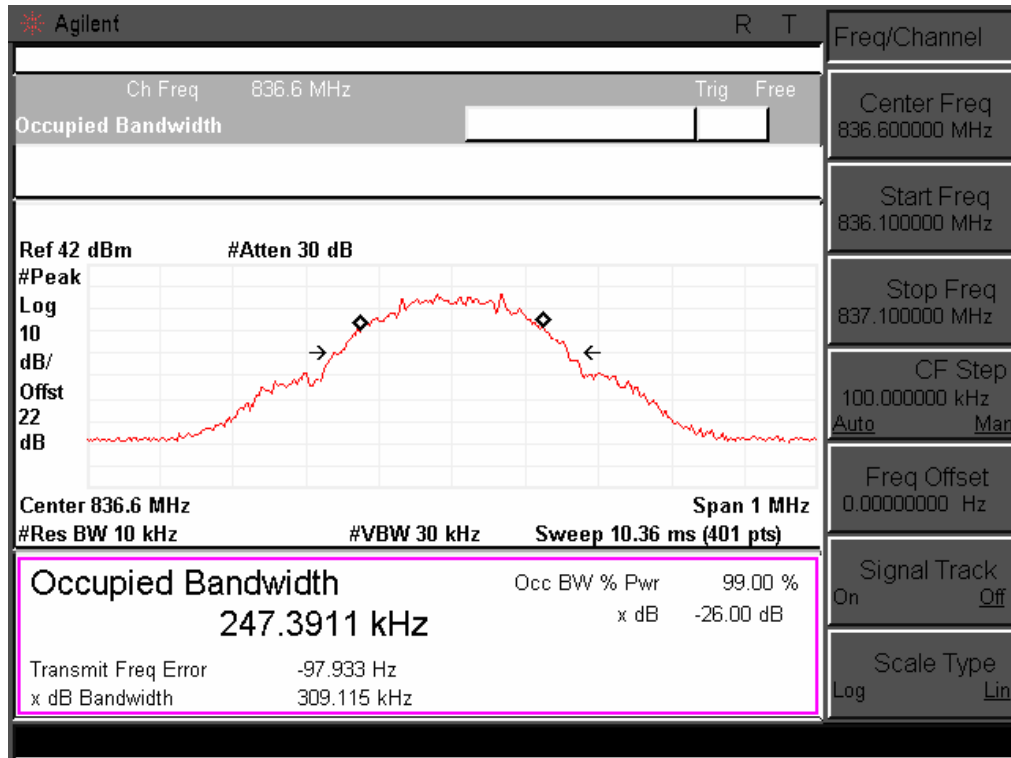

Channel 251

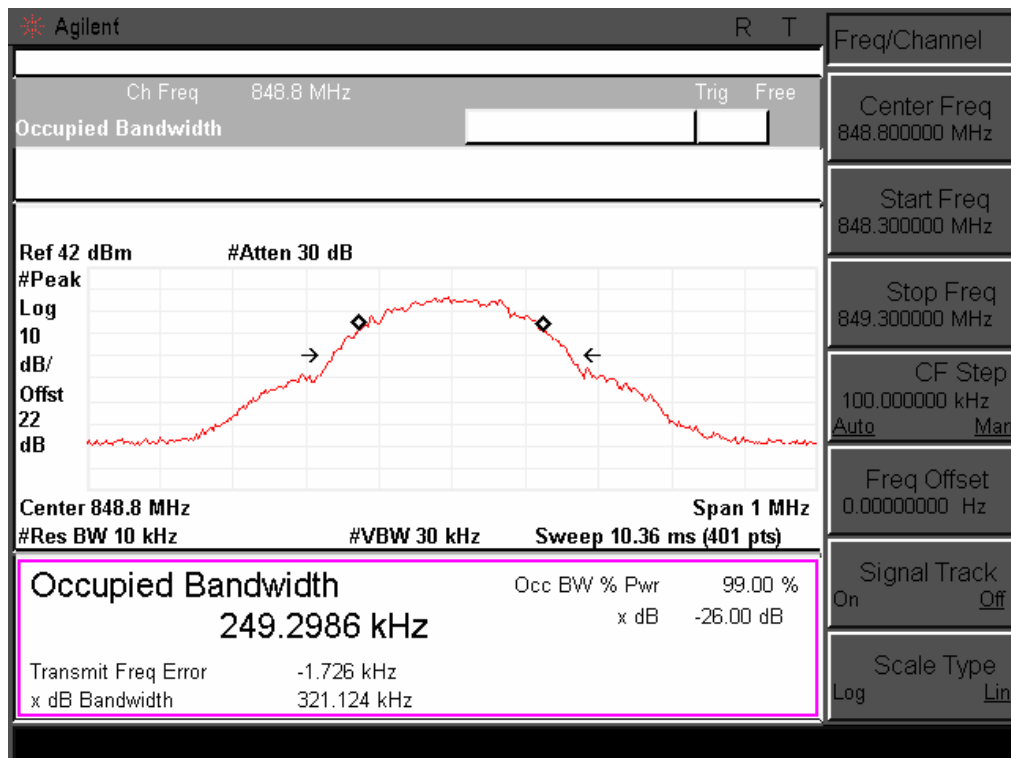



Test Item	Occupied Bandwidth
Test Mode	EDGE 1900
Test Date	2014-04-08

Channel No.	Frequency (MHz)	Measurement Level (kHz)
512	1850.2	318.478
661	1880.0	317.886
810	1909.8	317.168

Channel 512

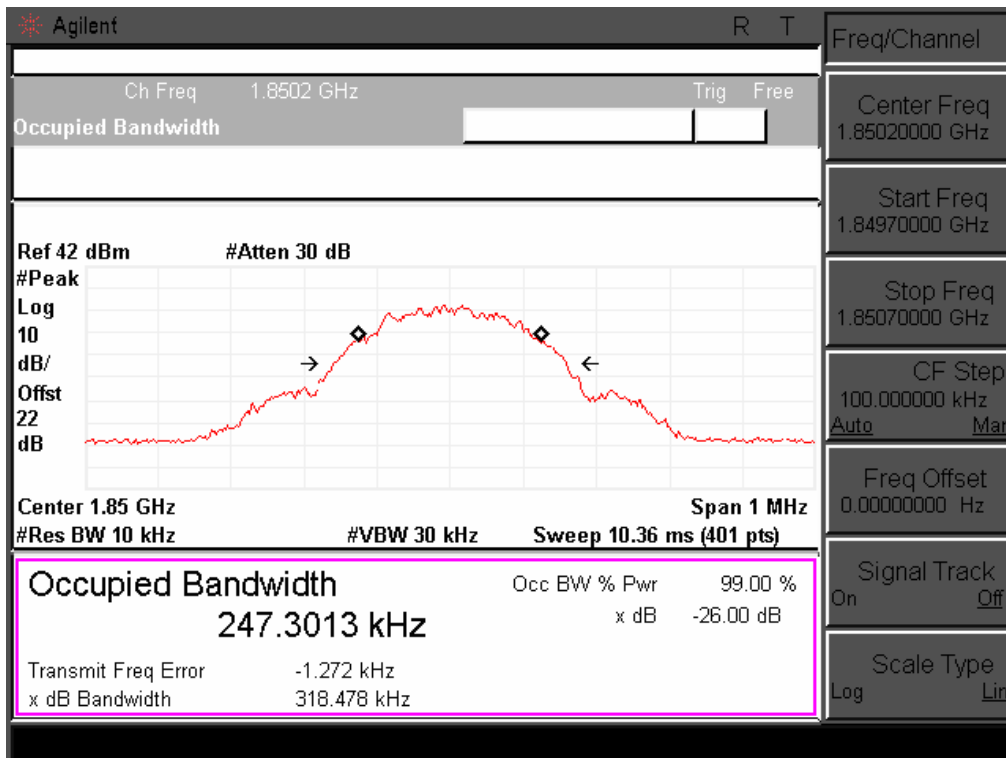



Channel 661

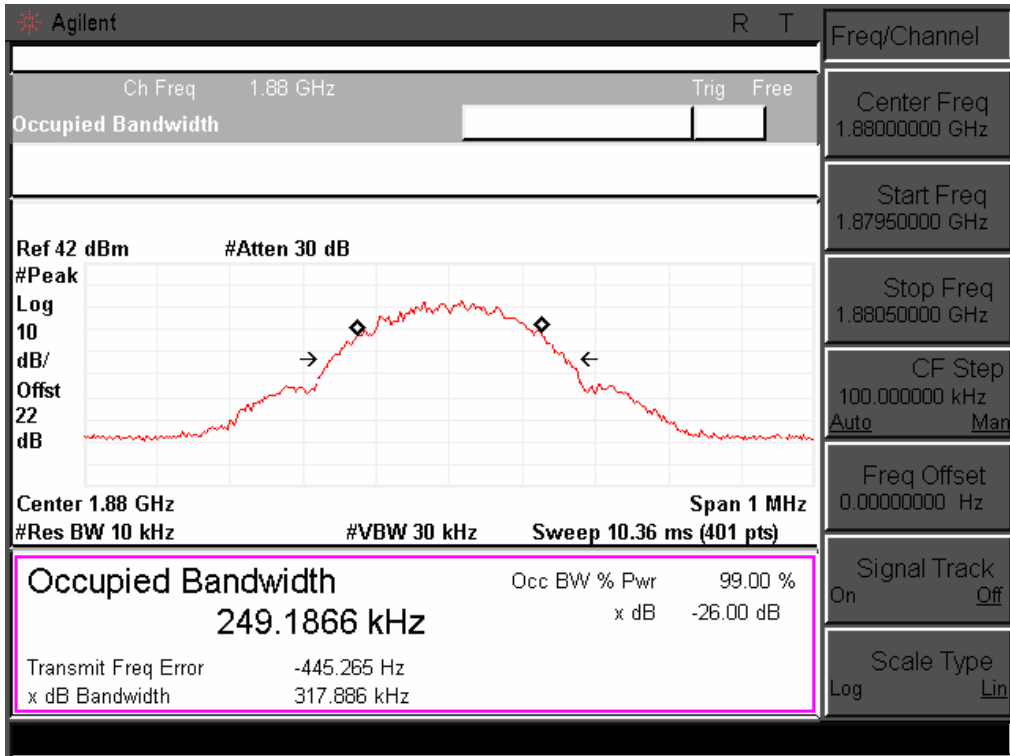

Channel 810

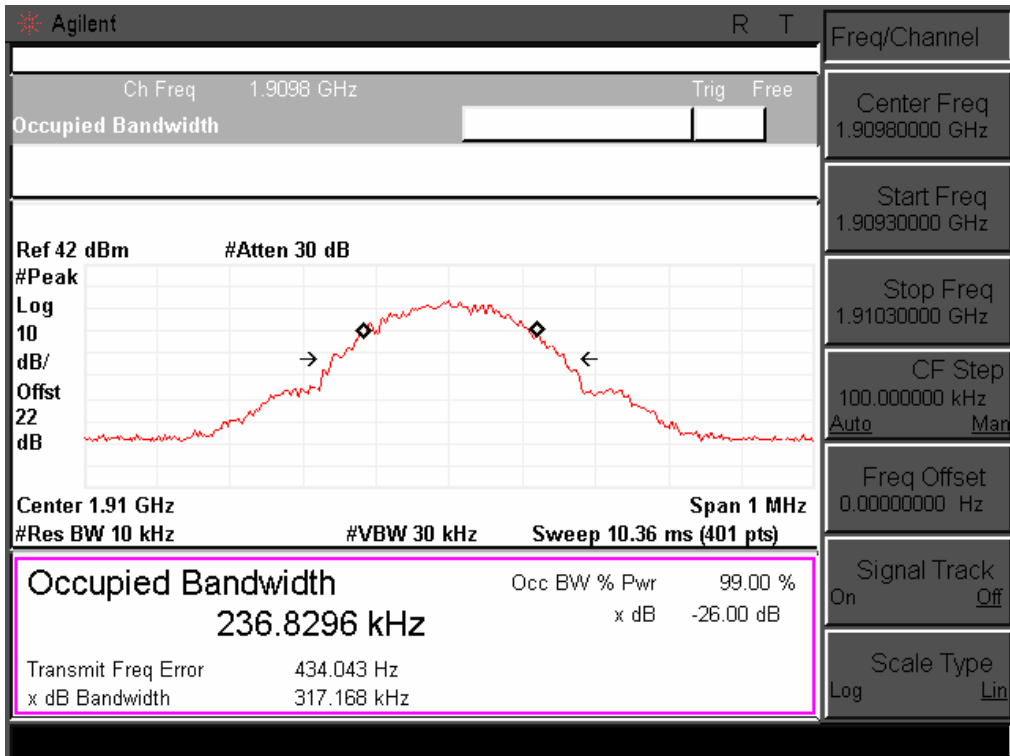



Test Item	Occupied Bandwidth
Test Mode	HSUPA 850
Test Date	2014-04-08

Channel No.	Frequency (MHz)	Measurement Level (kHz)
4132	826.4	4702
4183	836.6	4688
4233	846.6	4662

Channel 4132

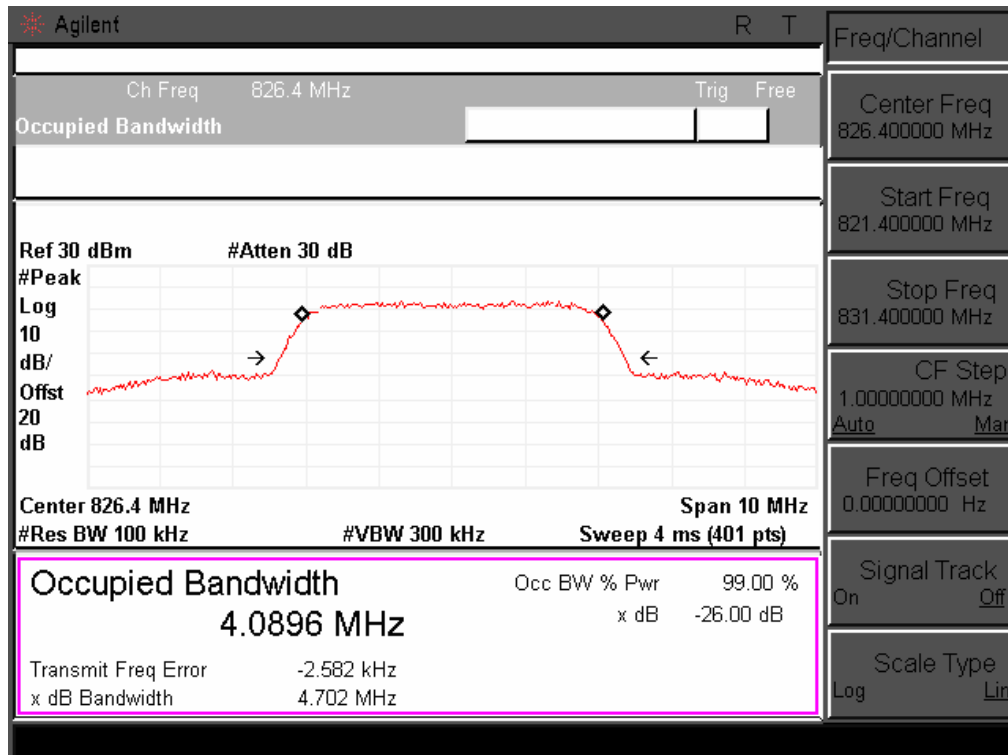



Channel 4183

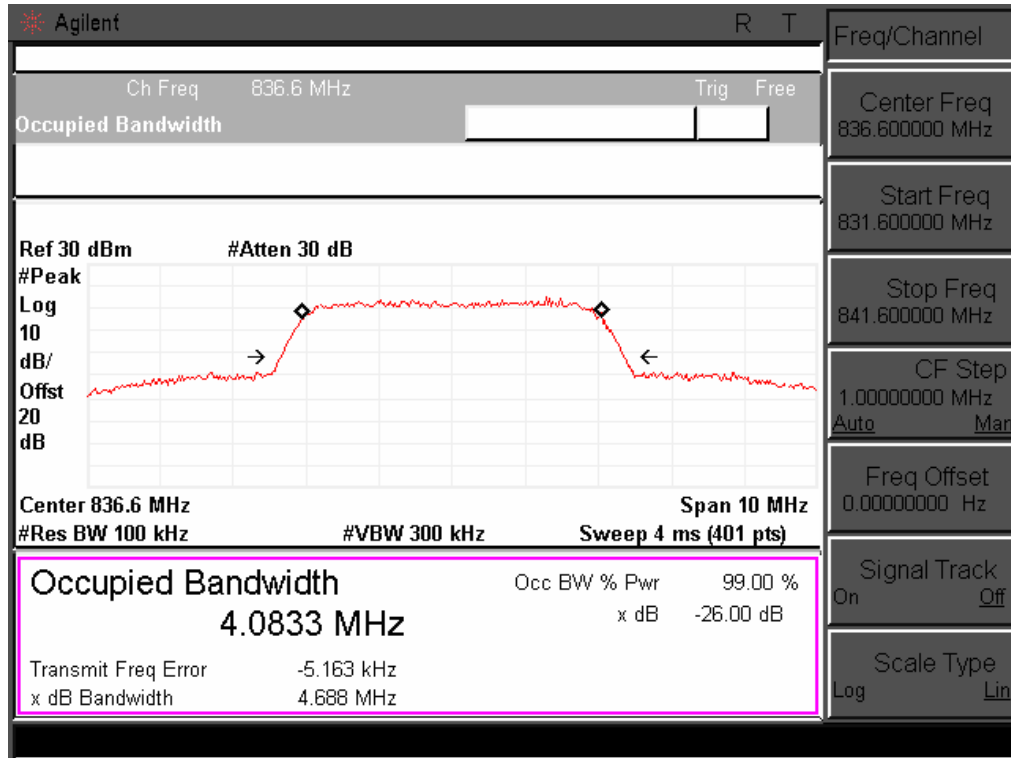

Channel 4233

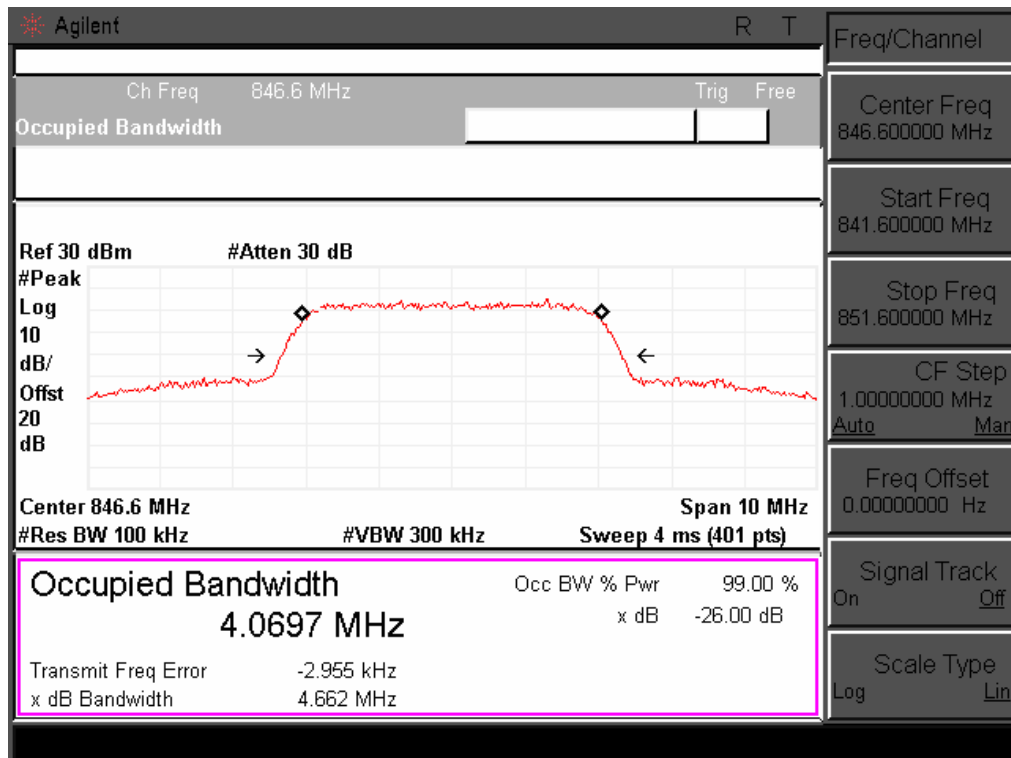



Test Item	Occupied Bandwidth
Test Mode	HSUPA 1900
Test Date	2014-04-08

Channel No.	Frequency (MHz)	Measurement Level (kHz)
9262	1852.4	4724
9400	1880.0	4684
9538	1907.6	4710

Channel 9262

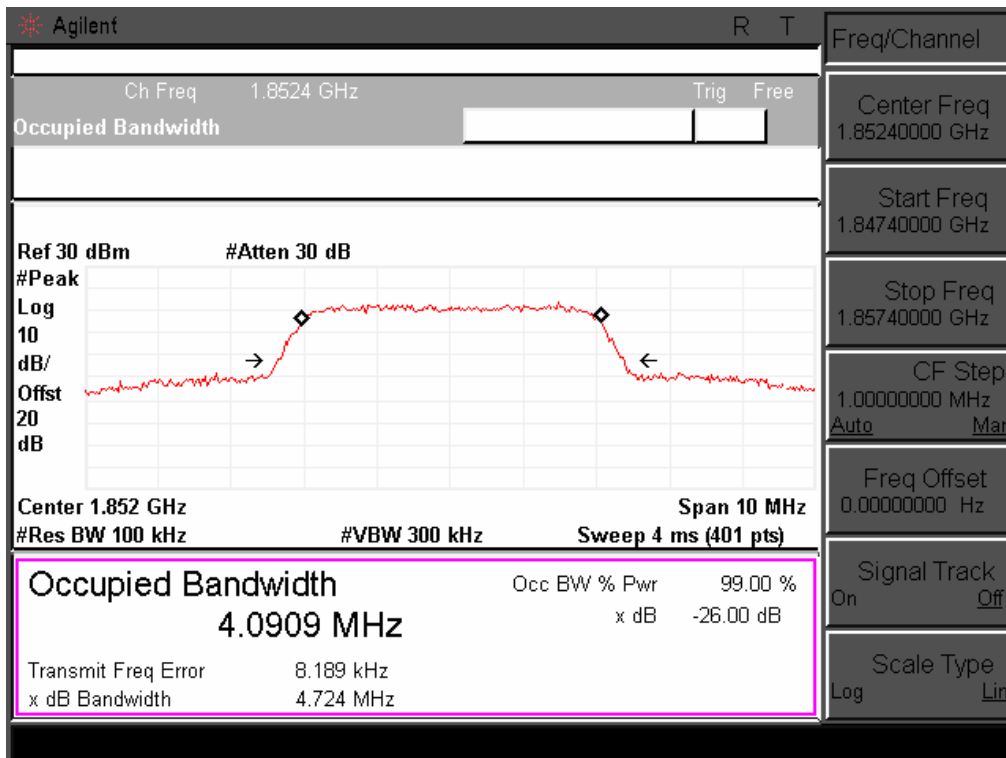





Channel 9400

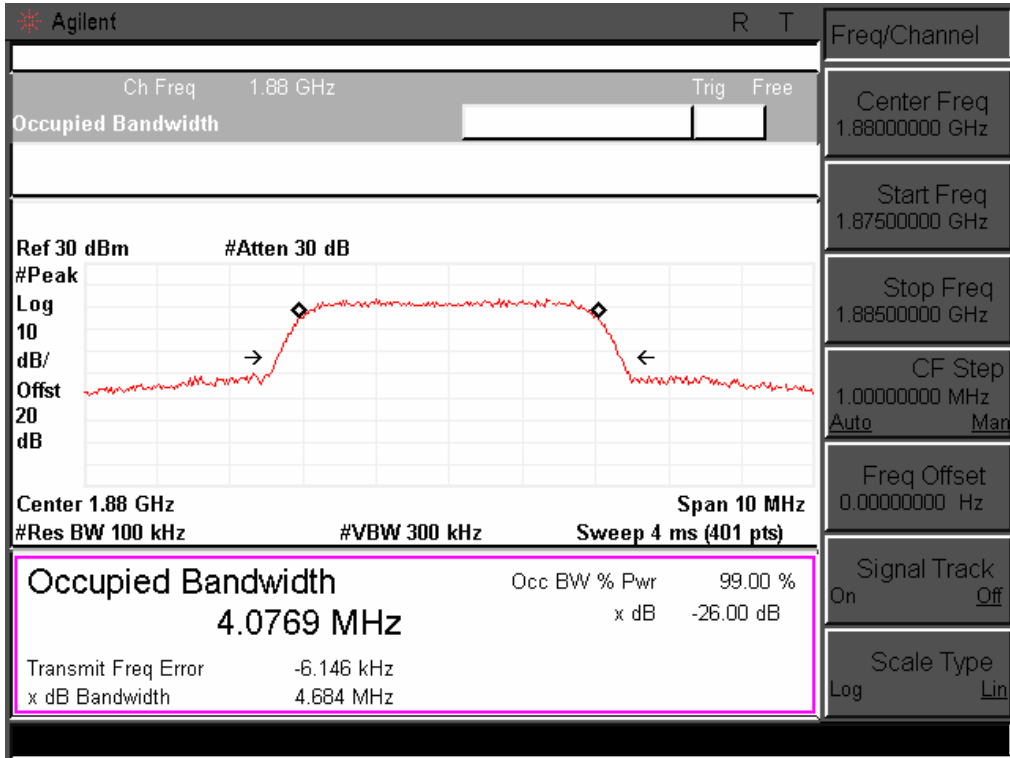

Channel 9538

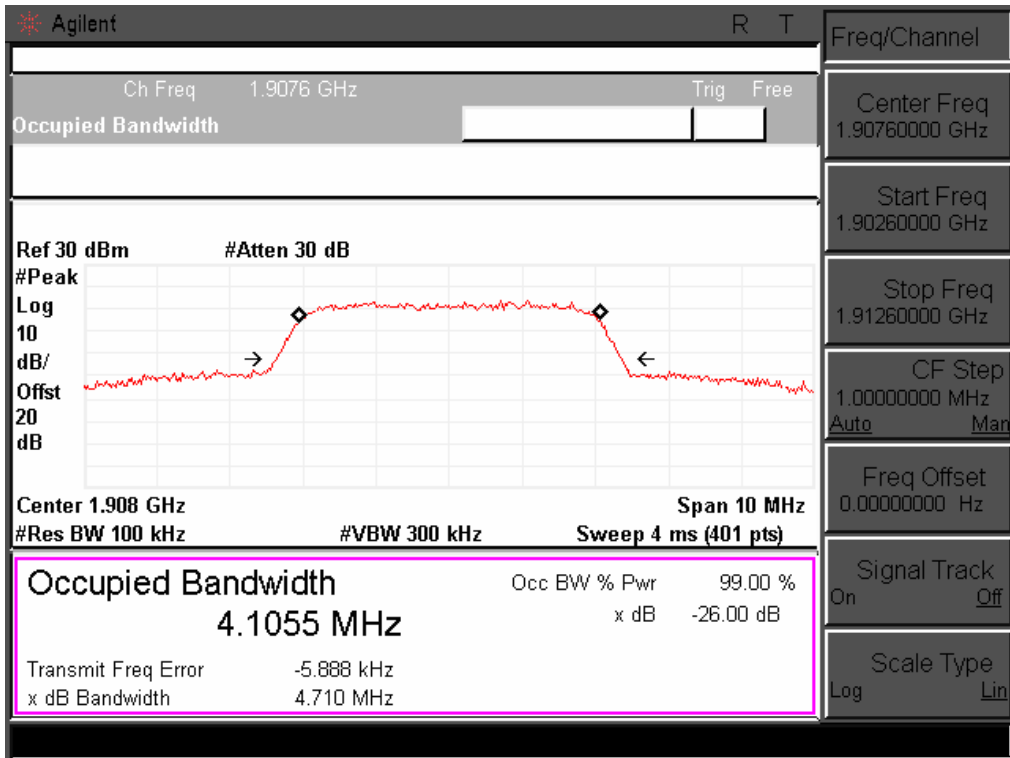



Test Item	Occupied Bandwidth
Test Mode	HSUPA 1700
Test Date	2014-04-08

Channel No.	Frequency (MHz)	Measurement Level (kHz)
1312	1712.4	4668
1413	1732.6	4659
1513	1752.6	4672

Channel 4132

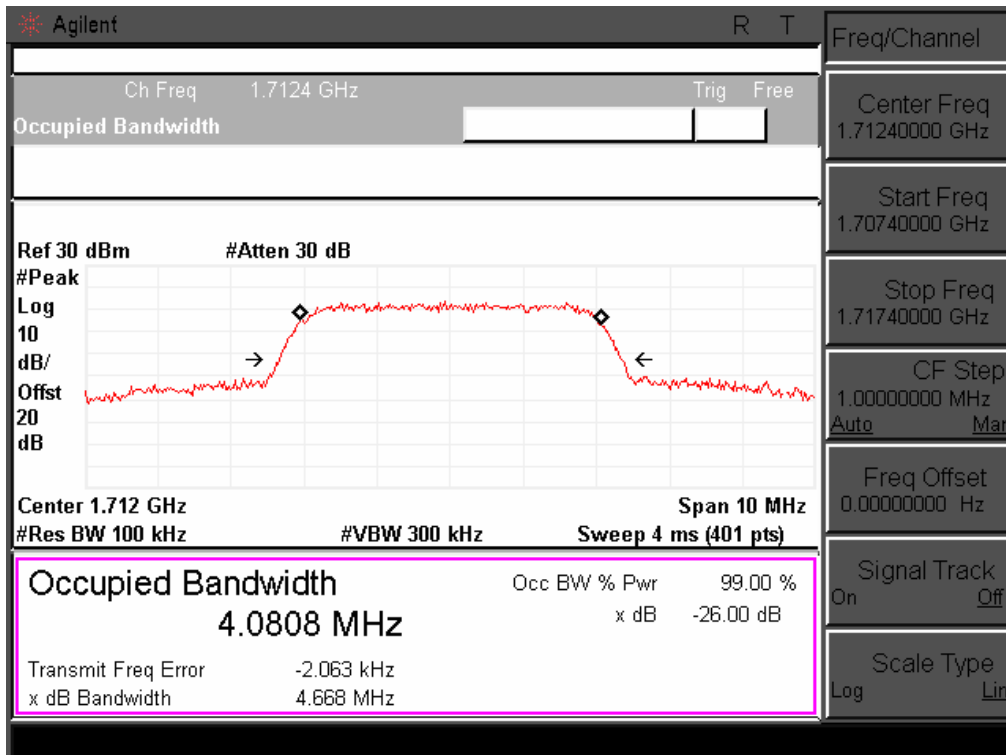



Channel 4183

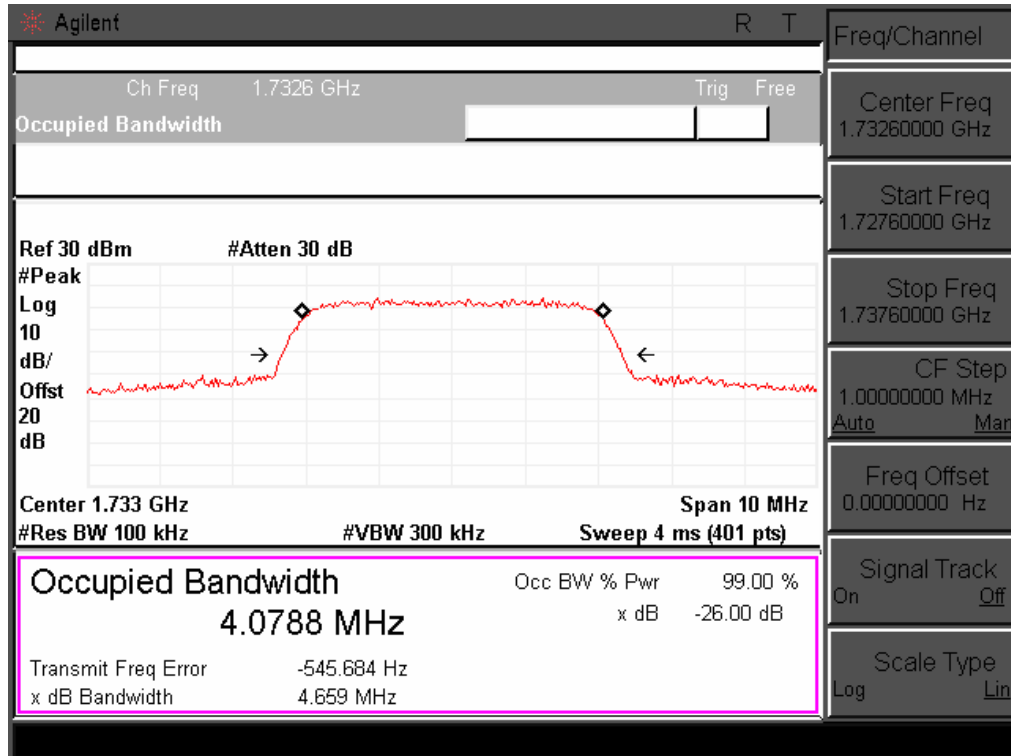

Channel 4233

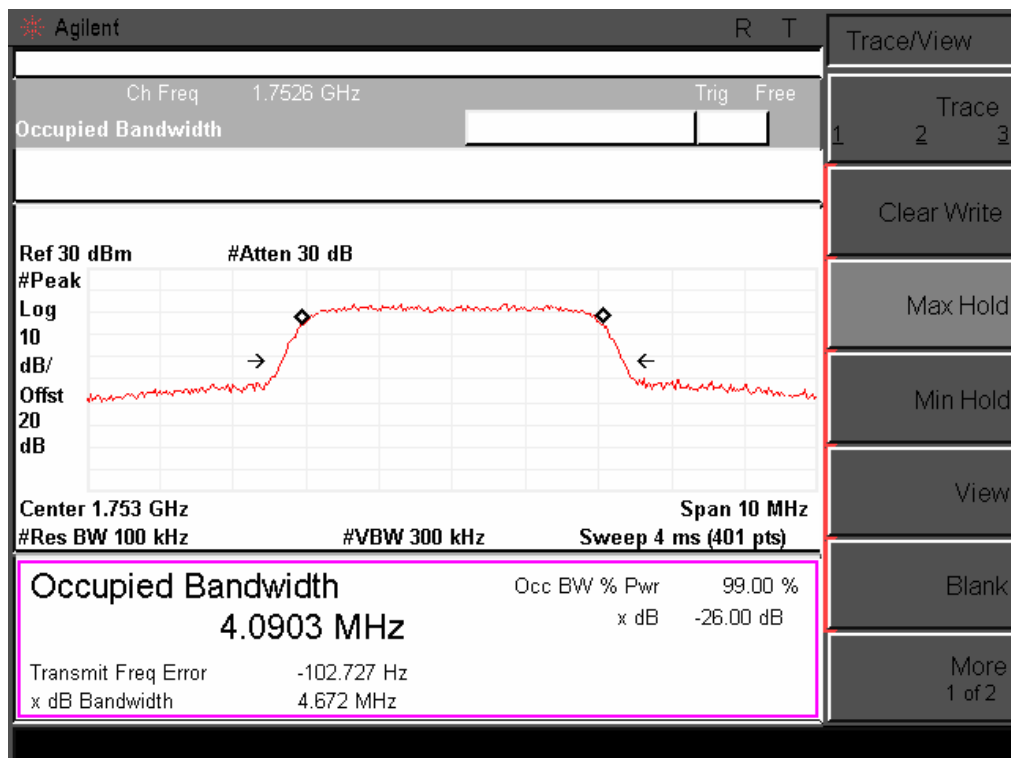



Test Item	Occupied Bandwidth
Test Mode	HSDPA 850
Test Date	2014-04-08

Channel No.	Frequency (MHz)	Measurement Level (kHz)
4132	826.4	4655
4183	836.6	4685
4233	846.6	4671

Channel 4132

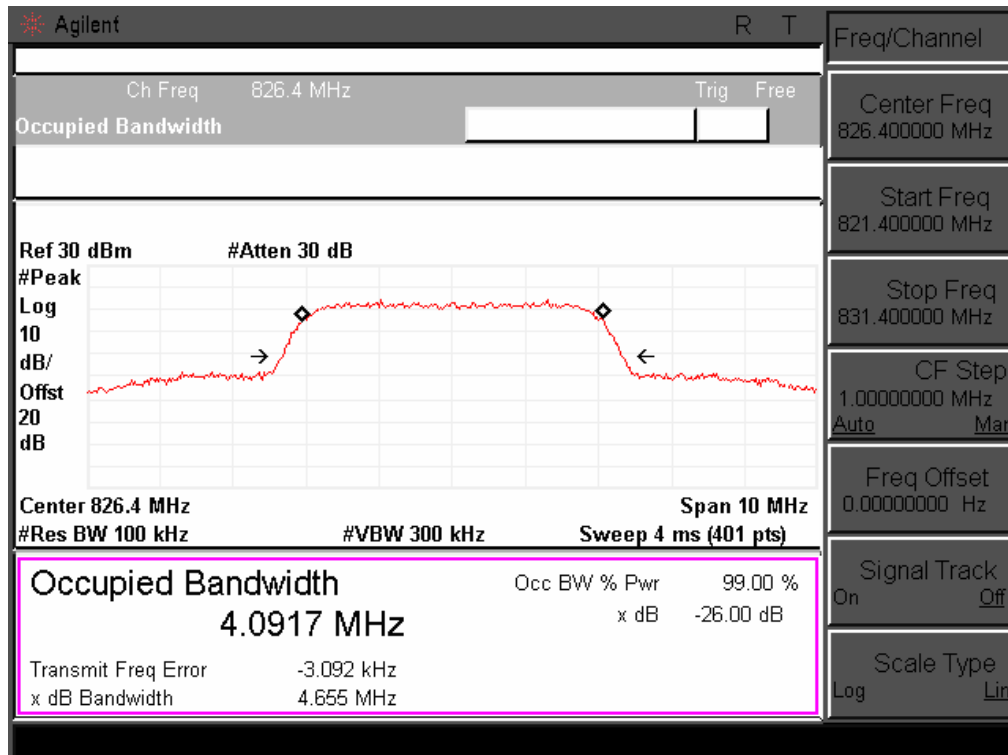



Channel 4183

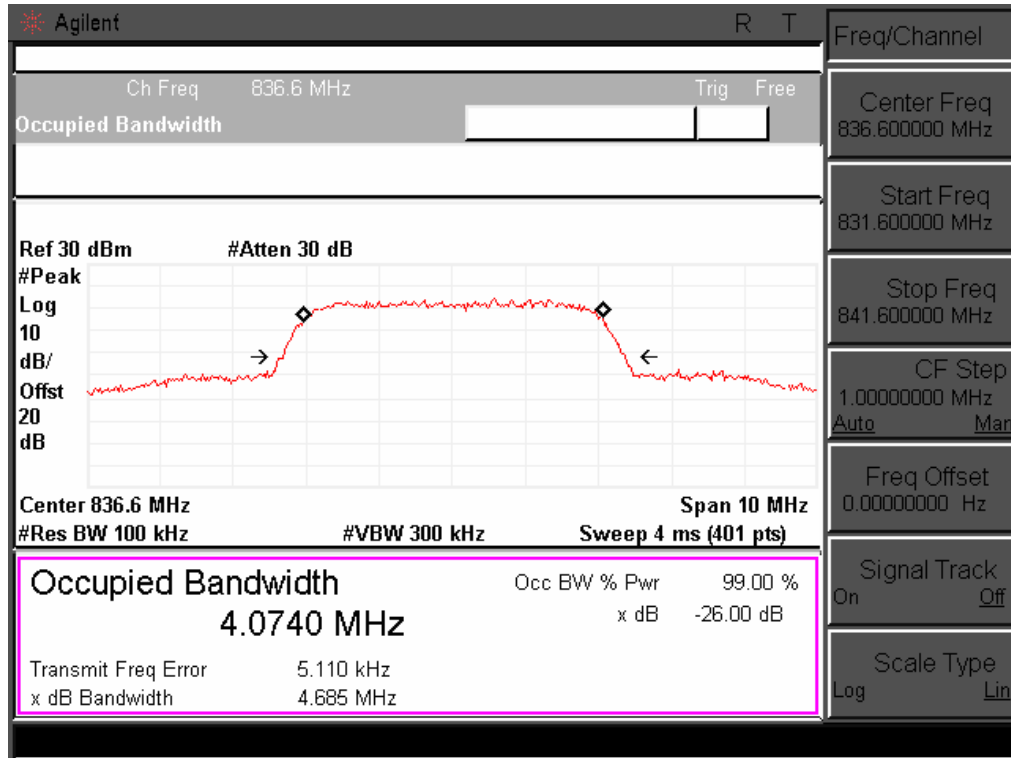

Channel 4233

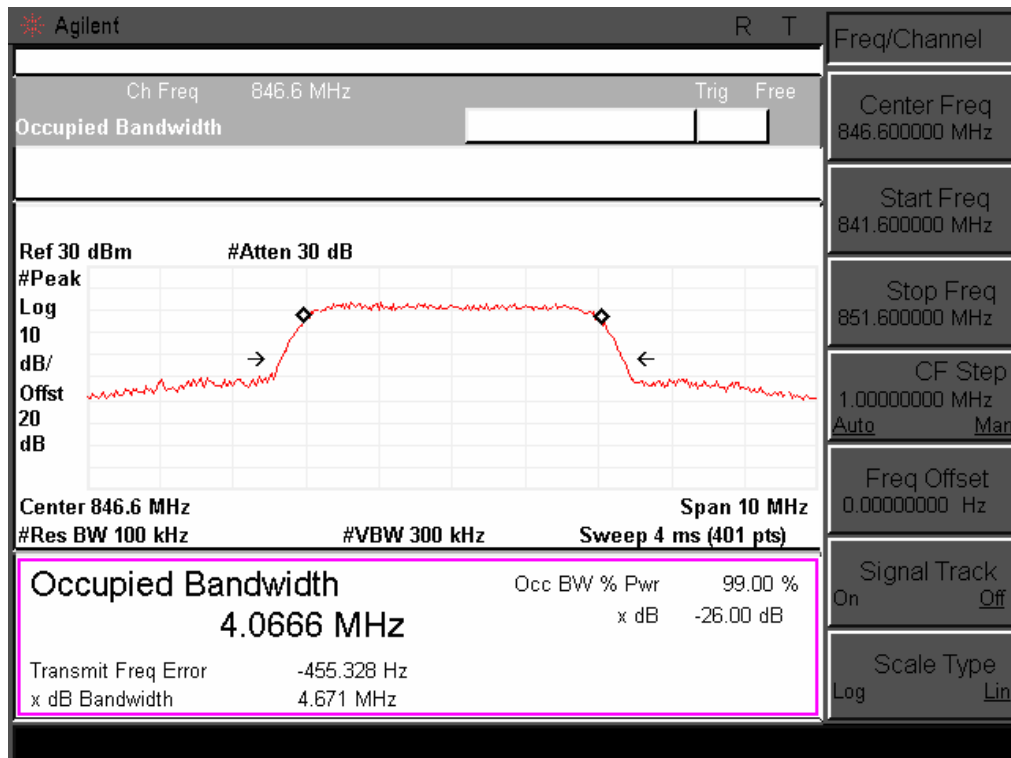



Test Item	Occupied Bandwidth
Test Mode	HSDPA 1900
Test Date	2014-04-08

Channel No.	Frequency (MHz)	Measurement Level (kHz)
9262	1852.4	4705
9400	1880.0	4658
9538	1907.6	4735

Channel 9262

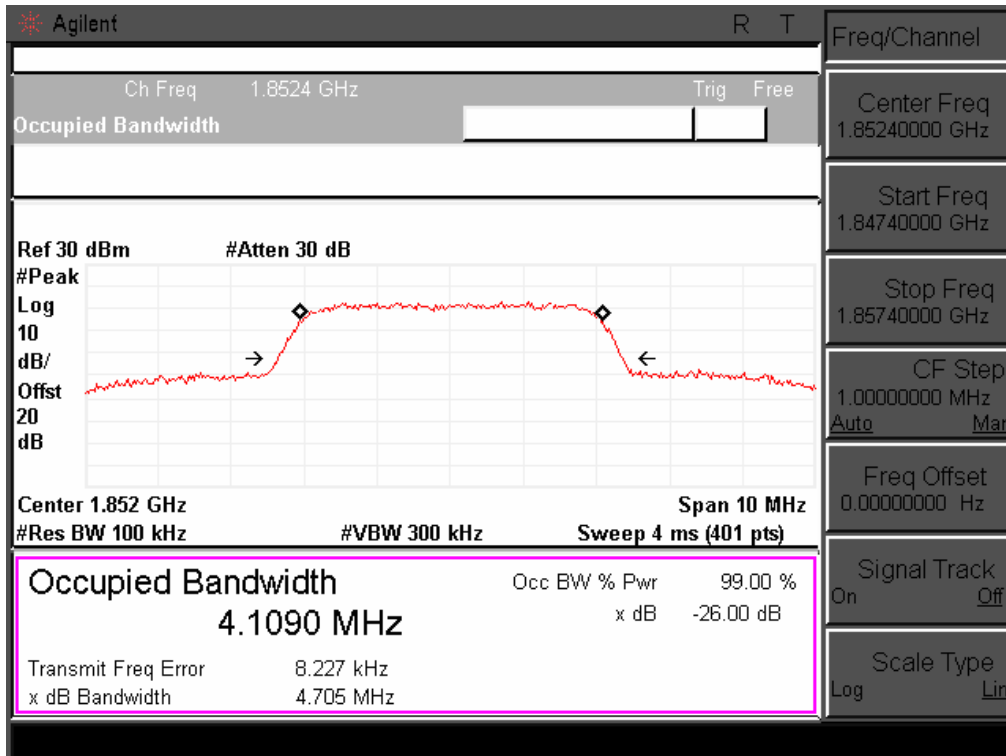



Channel 9400

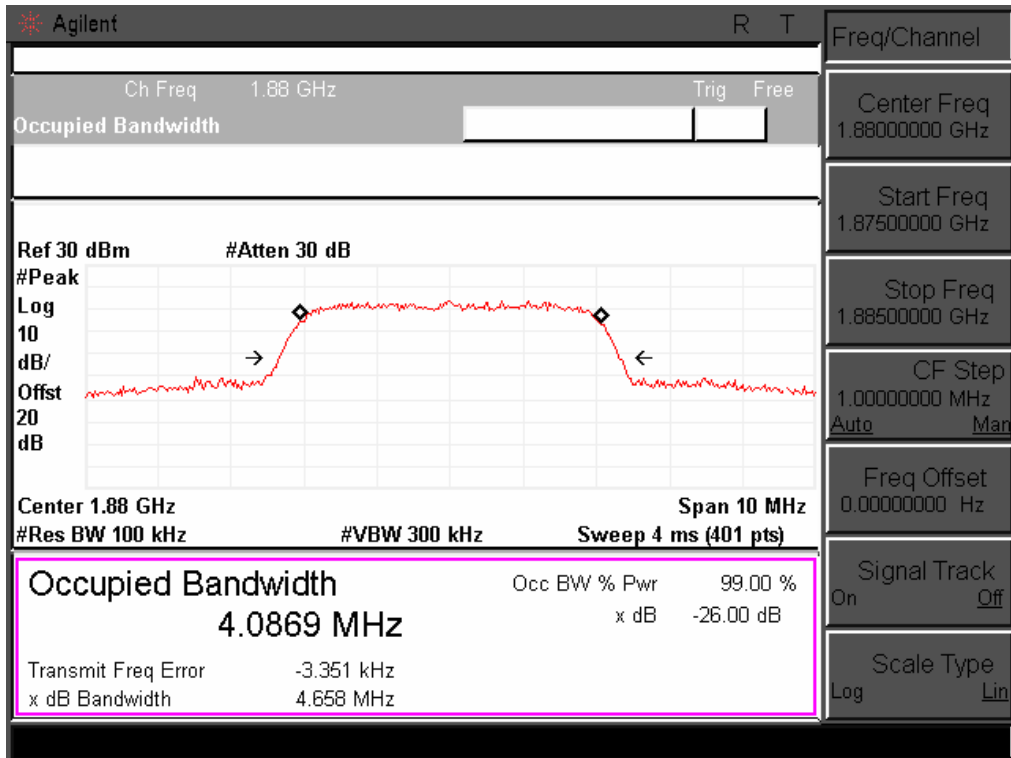

Channel 9538

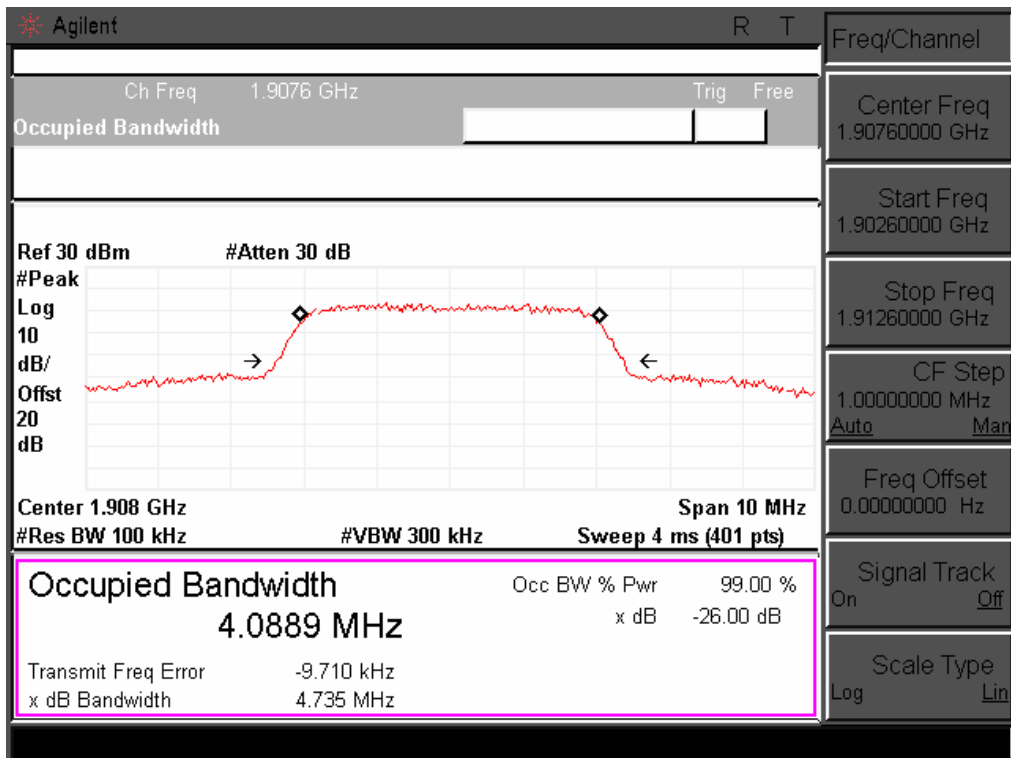



Test Item	Occupied Bandwidth
Test Mode	HSDPA 1700
Test Date	2014-04-08

Channel No.	Frequency (MHz)	Measurement Level (kHz)
1312	1712.4	4707
1413	1732.5	4671
1513	1752.6	4674

Channel 9262

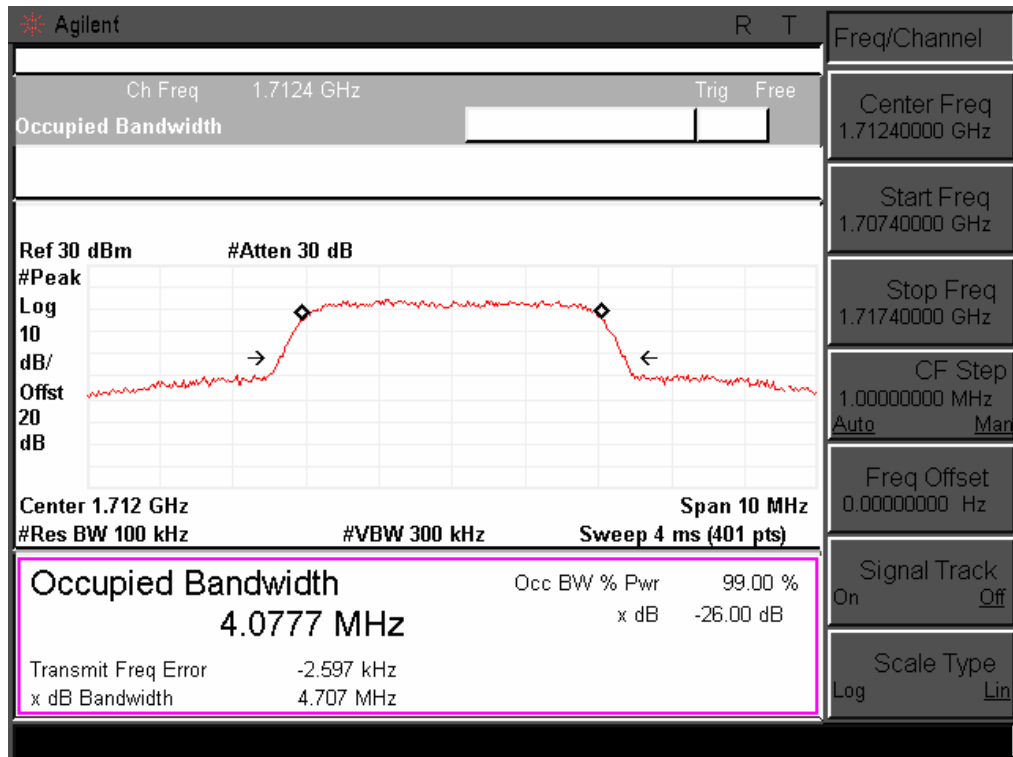





Channel 9400

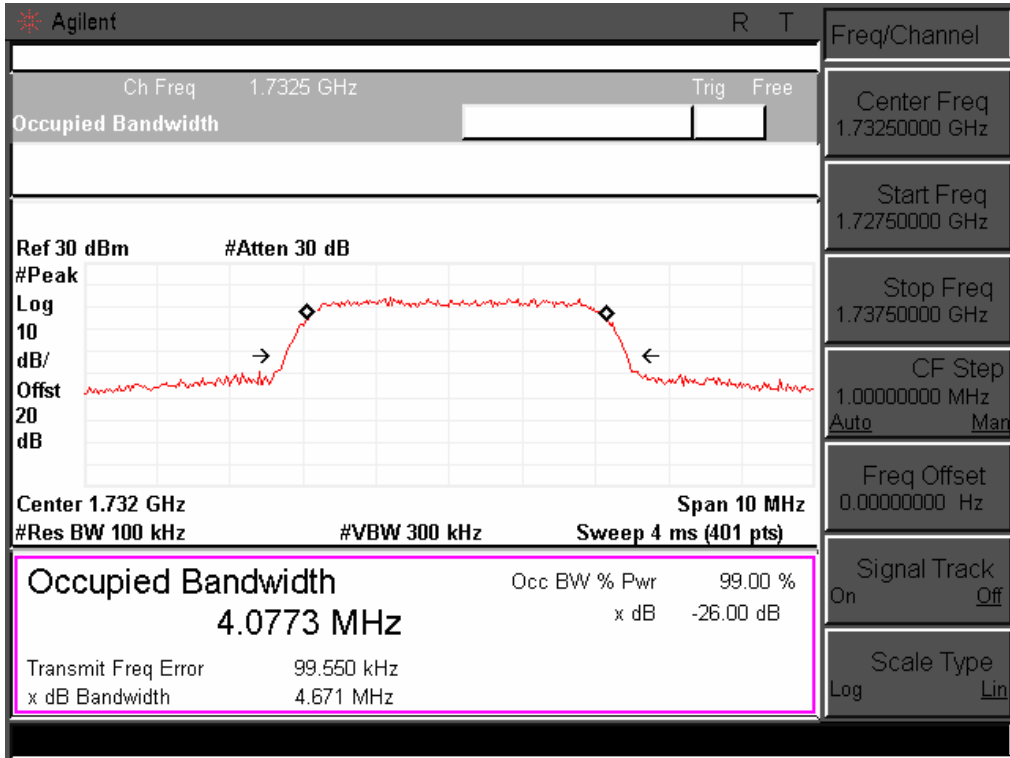

Channel 9538

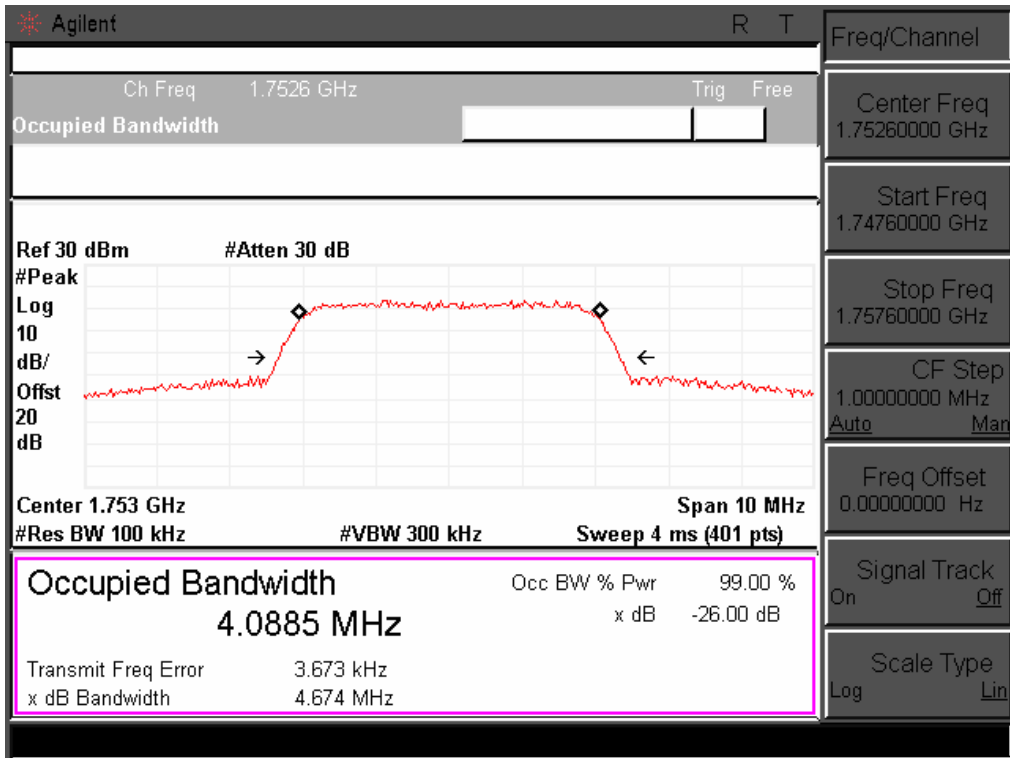



## 6. Maximum Peak Output Power

### 6.1. Test Limit

According to FCC §2.1046.

### 6.2. Test Procedure

- a) Place the EUT on a bench and set it in transmitting mode.
- b) Connect a low loss RF cable from the antenna port to a spectrum analyzer and CMU200 by a Directional Coupler.
- c) EUT Communicate with CMU200, then selects a channel for testing.
- d) Add a correction factor to the display of spectrum, and then test.

### 6.3. Test Setup Layout

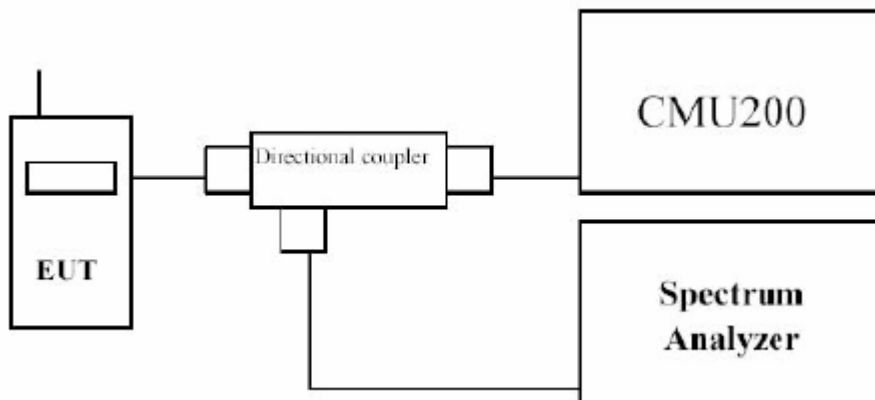

### 6.4. Measurement Equipment

Instrument/Ancillary	Manufacturer	Model No.	Serial No.	Calibration Date	Valid Date
Spectrum Analyzer	Agilent	E4407B	MY44211883	2013.09.25	2014.09.25
Temperature/ Humidity Meter	Zhicheng	ZC1-11	CEP-TH-002	2014.03.10	2015.03.09
Universal Radio Communication Tester	R&S	CMU200	108823	2014.01.09	2015.01.08



6.5. Test Result and Data

Test Item	Maximum Peak Output Power
Test Mode	EDGE 850
Test Date	2014-04-08

Channel No.	Frequency (MHz)	Peak Power (dBm)
128	824.2	31.14
190	836.6	31.24
251	848.8	31.45

Test Item	Maximum Peak Output Power
Test Mode	EDGE 1900
Test Date	2014-04-08

Channel No.	Frequency (MHz)	Peak Power (dBm)
512	1850.2	25.67
661	1880.0	25.84
810	1909.8	26.21



Test Item	Maximum Peak Output Power
Test Mode	HSUPA 850
Test Date	2014-04-08

Channel No.	Frequency (MHz)	Peak Power (dBm)
4132	826.4	22.45
4183	836.6	22.56
4233	846.6	<b>22.89</b>

Test Item	Maximum Peak Output Power
Test Mode	HSUPA 1900
Test Date	2014-04-08

Channel No.	Frequency (MHz)	Peak Power (dBm)
9262	1852.4	22.12
9400	1880.0	22.37
9538	1907.6	<b>22.68</b>

Test Item	Maximum Peak Output Power
Test Mode	HSUPA 1700
Test Date	2014-04-08

Channel No.	Frequency (MHz)	Peak Power (dBm)
1312	1712.4	21.67
1413	1732.5	21.78
1513	1752.6	21.99



Test Item	Maximum Peak Output Power
Test Mode	HSDPA 850
Test Date	2014-04-08

Channel No.	Frequency (MHz)	Peak Power (dBm)
4132	826.4	22.37
4183	836.6	22.60
4233	846.6	22.78

Test Item	Maximum Peak Output Power
Test Mode	HSDPA 1900
Test Date	2014-04-08

Channel No.	Frequency (MHz)	Peak Power (dBm)
9262	1852.4	21.98
9400	1880.0	22.31
9538	1907.6	22.54

Test Item	Maximum Peak Output Power
Test Mode	HSDPA 1700
Test Date	2014-04-08

Channel No.	Frequency (MHz)	Peak Power (dBm)
1312	1712.4	21.77
1413	1732.5	21.92
1513	1752.6	<b>22.31</b>



## 7. ERP & EIRP MEASUREMENT

### 7.1. Test Limit

According to FCC §2.1046

FCC 22.913(a): The Effective Radiated Power (ERP) of mobile transmitters must not exceed 7 Watts.

FCC 24.232(b): The equivalent Isotropic Radiated Power (EIRP) must not exceed 2 Watts.

### 7.2. Test Procedure

The EUT was placed on a non-conductive turntable using a non-conductive support. The radiated emission at the fundamental frequency was measured at 3 m with a test antenna and EMI spectrum analyzer.

During the measurement of the EUT, the resolution bandwidth was set to 3MHz and the average bandwidth was set to 3MHz. The highest emission was recorded with the rotation of the turntable and the lowering of the test antenna. The reading was recorded and the field strength (E in dBuV/m) was calculated.

ERP in frequency band 824-849MHz, and EIRP in frequency band 1850 –1910MHz were measured using a substitution method. The EUT was replaced by half-wave dipole (824-849MHz) or horn antenna (1850-1910MHz) connected to a signal generator. The spectrum analyzer reading was recorded and ERP/EIRP was calculated as follows:

$$\text{ERP} = \text{S.G. output (dBm)} + \text{Antenna Gain (dBd)} - \text{Cable (dB)}$$

$$\text{EIRP} = \text{S.G. output (dBm)} + \text{Antenna Gain (dBi)} - \text{Cable (dB)}$$



### 7.3. Test Setup Layout

#### Below 1 GHz

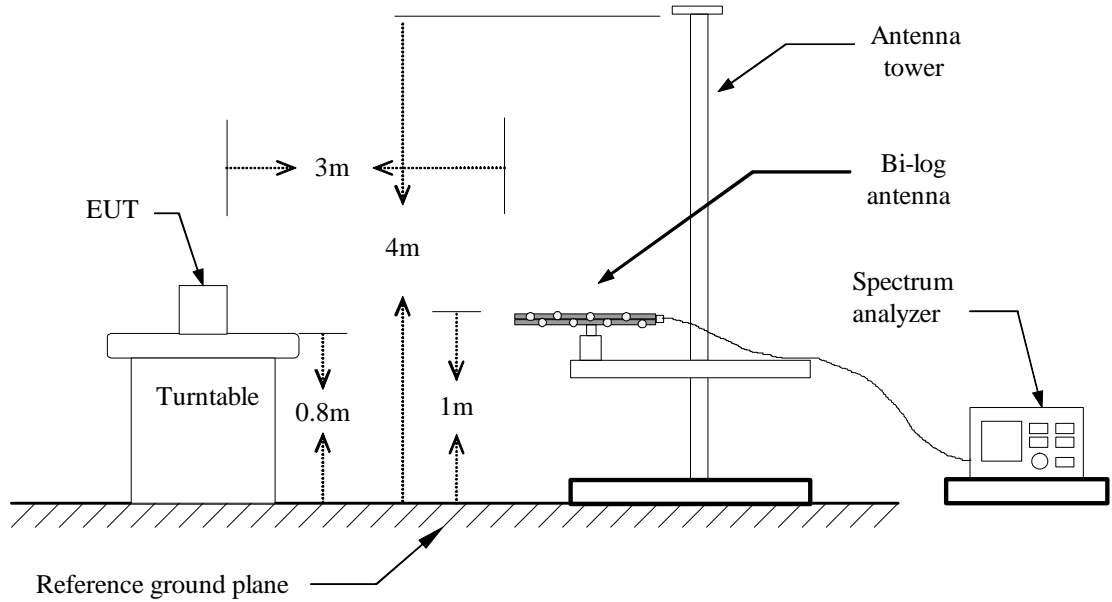

#### Above 1 GHz

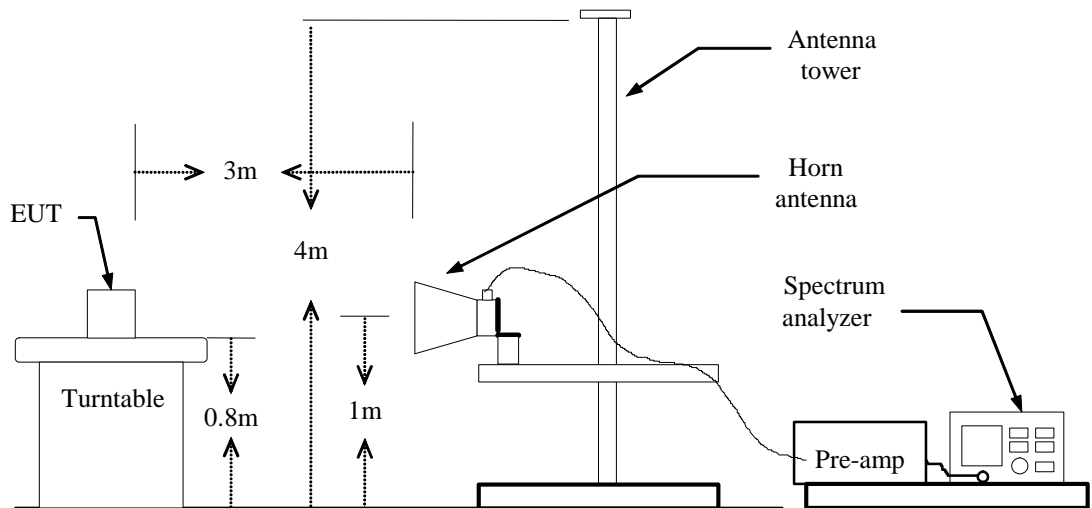



**For Substituted Method Test Set-UP**

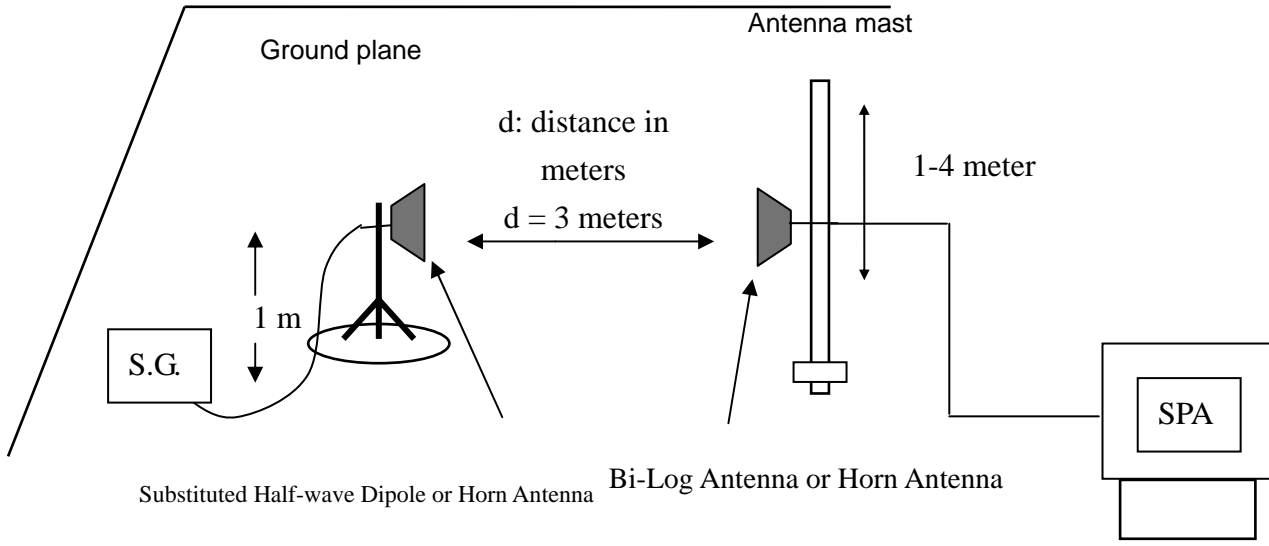

**7.4. Measurement Equipment**

Instrument/Ancillary	Model No.	Manufacturer	Serial No.	Calibration Date	Valid Date
Spectrum Analyzer	R&S	FSP40	100324	2014.03.10	2015.03.09
H64 Amplifier	HP	8447F	3113A05582	2014.03.10	2015.03.09
Preamplifier	Agilent	8449B	ED-HE-EMI-077	2014.03.10	2015.03.09
Broad-Band Horn Antenna	Schwarzbeck	BBHA9120D	9120D-619	2013.05.03	2014.05.02
Broad-Band Horn Antenna	Schwarzbeck	BBHA9120D	9120D-618	2013.05.03	2014.05.02
Temperature/ Humidity Meter	Zhicheng	ZC1-11	CEP-TH-002	2014.03.10	2015.03.09





7.5. Test Result and Data

**EDGE 850 TEST DATA**

Channel	Frequency (MHz)	Antenna Pol.	Reading level (Peak) (dB)	Correction Factor (dB)	Emission level (dBm)	Limit (dBm)	Margin (dB)
128	824.2	V	26.75	1.01	27.76	38.5	-10.74
	824.2	H	26.6	0.96	27.56	38.5	-10.94
190	836.6	V	25.67	1.77	27.44	38.5	-11.06
	836.6	H	25.85	1.46	27.31	38.5	-11.19
251	848.8	V	25.49	1.85	27.34	38.5	-11.16
	848.8	H	25.55	1.54	27.09	38.5	-11.41

**EDGE 1900 TEST DATA**

Channel	Frequency (MHz)	Antenna Pol.	Reading level (Peak) (dB)	Correction Factor (dB)	Emission level (dBm)	Limit (dBm)	Margin (dB)
512	1852.4	V	24.74	2.34	27.08	33	-5.92
	1852.4	H	25.04	1.88	26.92	33	-6.08
661	1880	V	24.83	2.12	26.95	33	-6.05
	1880	H	24.36	2.41	26.77	33	-6.23
810	1907.6	V	24.49	2.34	26.83	33	-6.17
	1907.6	H	24.56	1.98	26.54	33	-6.46



**HSUPA 850 TEST DATA**

Channel	Frequency (MHz)	Antenna Pol.	Reading level (Peak) (dB)	Correction Factor (dB)	Emission level (dBm)	Limit (dBm)	Margin (dB)
4132	826.4	V	20.87	1.01	21.88	38.5	-16.62
	826.4	H	20.13	0.96	21.09	38.5	-17.41
4183	836.6	V	19.65	1.77	21.42	38.5	-17.08
	836.6	H	19.24	1.46	20.7	38.5	-17.8
4233	846.6	V	19.9	1.85	21.75	38.5	-16.75
	846.6	H	18.22	1.54	19.76	38.5	-18.74

**HSUPA 1900 TEST DATA**

Channel	Frequency (MHz)	Antenna Pol.	Reading level (Peak) (dB)	Correction Factor (dB)	Emission level (dBm)	Limit (dBm)	Margin (dB)
9262	1852.4	V	19.66	2.34	22	33	-11
	1852.4	H	19.78	1.88	21.66	33	-11.34
9400	1880	V	19.11	2.12	21.23	33	-11.77
	1880	H	18.45	2.41	20.86	33	-12.14
9538	1907.6	V	19.78	2.34	22.12	33	-10.88
	1907.6	H	19.25	1.98	21.23	33	-11.77

**HSUPA 1700 TEST DATA**

Channel	Frequency (MHz)	Antenna Pol.	Reading level (Peak) (dB)	Correction Factor (dB)	Emission level (dBm)	Limit (dBm)	Margin (dB)
1312	1712.4	V	16.31	2.13	18.44	30	-11.56
	1712.4	H	16.18	1.93	18.11	30	-11.89
1413	1732.5	V	16.78	1.97	18.75	30	-11.25
	1732.5	H	16.65	1.89	18.54	30	-11.46
1513	1752.6	V	16.98	1.91	18.89	30	-11.11
	1752.6	H	16.74	1.84	18.58	30	-11.42



**HSDPA 850 TEST DATA**

Channel	Frequency (MHz)	Antenna Pol.	Reading level (Peak) (dB)	Correction Factor (dB)	Emission level (dBm)	Limit (dBm)	Margin (dB)
4132	826.4	V	20.45	1.01	21.46	38.5	-17.04
	826.4	H	20.2	0.96	21.16	38.5	-17.34
4183	836.6	V	19.45	1.77	21.22	38.5	-17.28
	836.6	H	19.34	1.46	20.8	38.5	-17.7
4233	846.6	V	19.65	1.85	21.5	38.5	-17
	846.6	H	19.24	1.54	20.78	38.5	-17.72

**HADPA 1900 TEST DATA**

Channel	Frequency (MHz)	Antenna Pol.	Reading level (Peak) (dB)	Correction Factor (dB)	Emission level (dBm)	Limit (dBm)	Margin (dB)
9262	1852.4	V	19.45	2.34	21.79	33	-11.21
	1852.4	H	19.23	1.88	21.11	33	-11.89
9400	1880	V	19.16	2.12	21.28	33	-11.72
	1880	H	18.45	2.41	20.86	33	-12.14
9538	1907.6	V	19.77	2.34	22.11	33	-10.89
	1907.6	H	19.89	1.98	21.87	33	-11.13

**HADPA 1700 TEST DATA**

Channel	Frequency (MHz)	Antenna Pol.	Reading level (Peak) (dB)	Correction Factor (dB)	Emission level (dBm)	Limit (dBm)	Margin (dB)
1312	1712.4	V	16.22	2.13	18.35	30	-11.65
	1712.4	H	16.04	1.93	17.97	30	-12.03
1413	1732.5	V	16.65	1.97	18.62	30	-11.38
	1732.5	H	16.48	1.89	18.37	30	-11.63
1513	1752.6	V	16.77	1.91	18.68	30	-11.32
	1752.6	H	16.59	1.84	18.43	30	-11.57



## 8. OUT OF BAND EMISSION AT ANTENNA TERMINALS

### 8.1. Test Limit

According to FCC §2.1051, FCC §22.917, FCC §24.238(a).

**Out of Band Emissions:** The mean power of emission must be attenuated below the mean power of the non-modulated carrier (P) on any frequency twice or more than twice the fundamental frequency by at least  $43 + 10 \log P$  dB.

**Mobile Emissions in Base Frequency Range:** The mean power of any emissions appearing in the base station frequency range from cellular mobile transmitters operated must be attenuated to a level not exceed  $-80$  dBm at the transmit antenna connector.

**Band Edge Requirements:** In the 1MHz bands immediately outside and adjacent to the frequency block, a resolution bandwidth of at least 1% of the emission bandwidth of the fundamental emission of the transmitter may be employed to measure the Out of band Emission.

### 8.2. Test Procedure

The RF output of the transceiver was connected to a spectrum analyzer through appropriate attenuation. The resolution bandwidth of the spectrum analyzer was set at 1MHz, sufficient scans were taken to show the out of band Emissions if any up to 10th harmonic.

For the out of band: Set the RBW, VBW = 1MHz, Start=30MHz, Stop= 10 th harmonic. Limit = -13dBm

Band Edge Requirements (824 MHz and 849 MHz /1850MHz and 1910MHz): In the 1 MHz bands immediately outside and adjacent to the frequency block, a resolution bandwidth of at least 1 percent of the emission bandwidth of the fundamental emission of the transmitter may be employed to measure the out of band Emissions. Limit, -13dBm.

### 8.3. Test Setup Layout

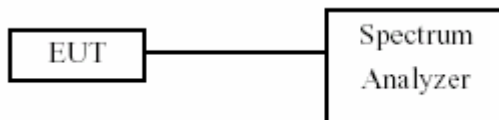

### 8.4. Measurement Equipment

Instrument/Ancillary	Model No.	Manufacturer	Serial No.	Calibration Date	Valid Date
Spectrum Analyzer	FSP40	R&S	100324	2013.03.10	2014.03.09
Temperature/ Humidity Meter	Zhicheng	ZC1-11	CEP-TH-002	2013.03.10	2014.03.09



8.5. Test Result and Data

Test Item	Conducted spurious emissions, 30MHz - 20GHz
Test Mode	EDGE 850
Test Date	2014-04-08

Channel 128

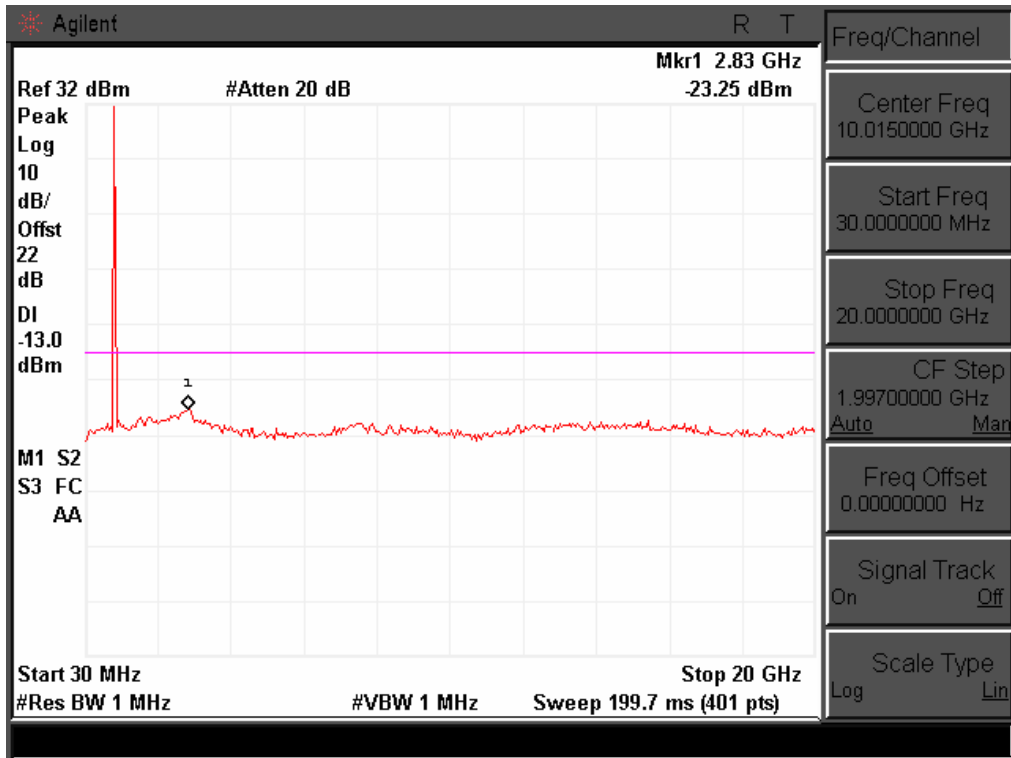



Channel 190

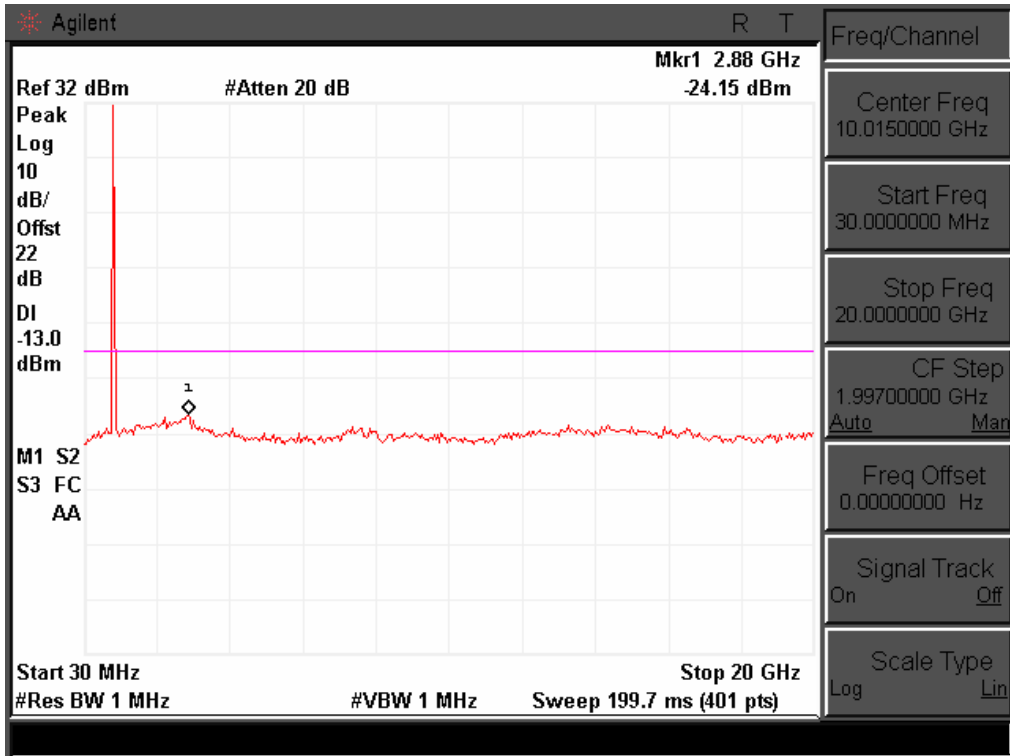

Channel 251

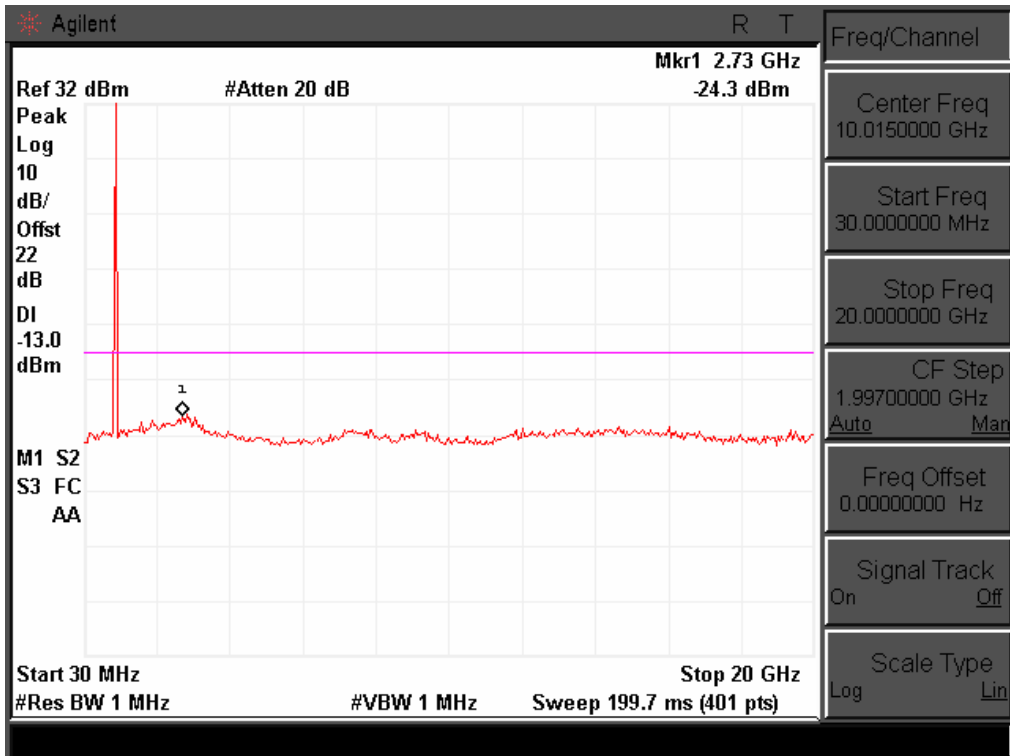



Test Item	Conducted spurious emissions, 30MHz - 20GHz
Test Mode	EDGE 1900
Test Date	2014-04-08

Channel 512

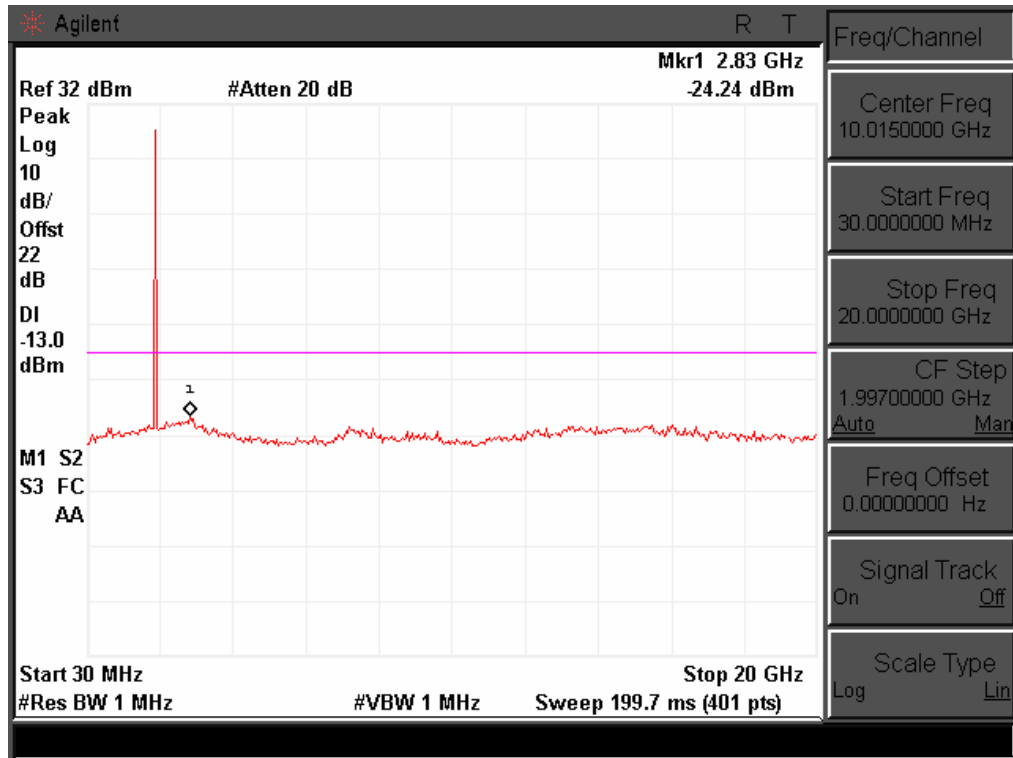



Channel 661

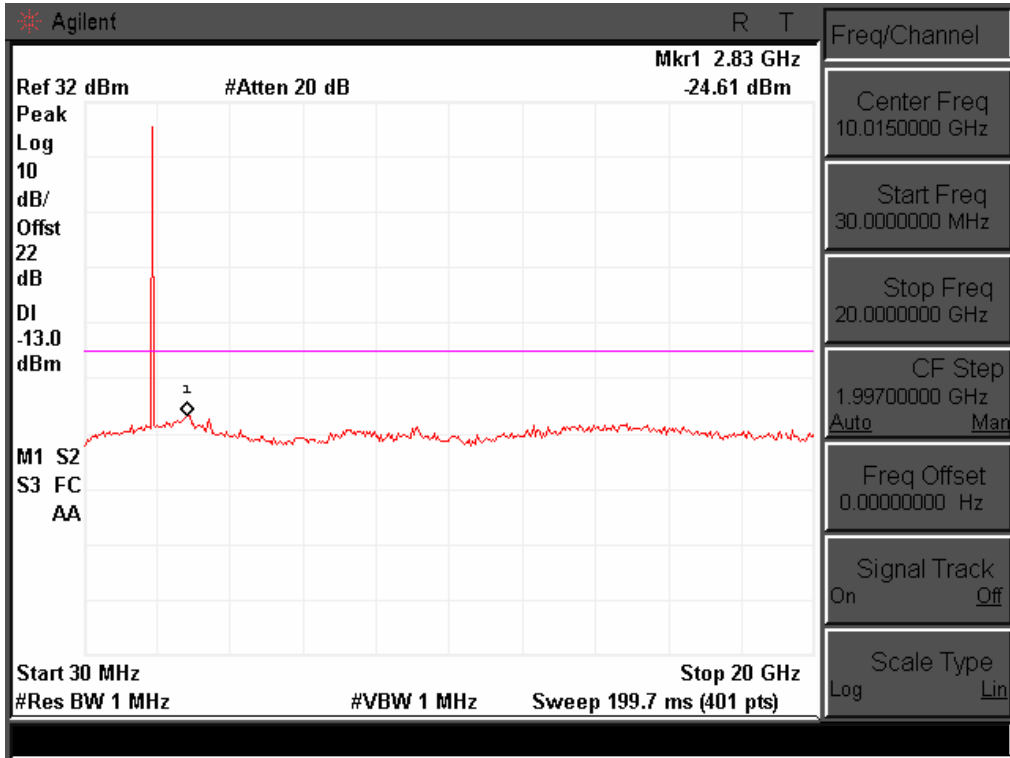

Channel 810

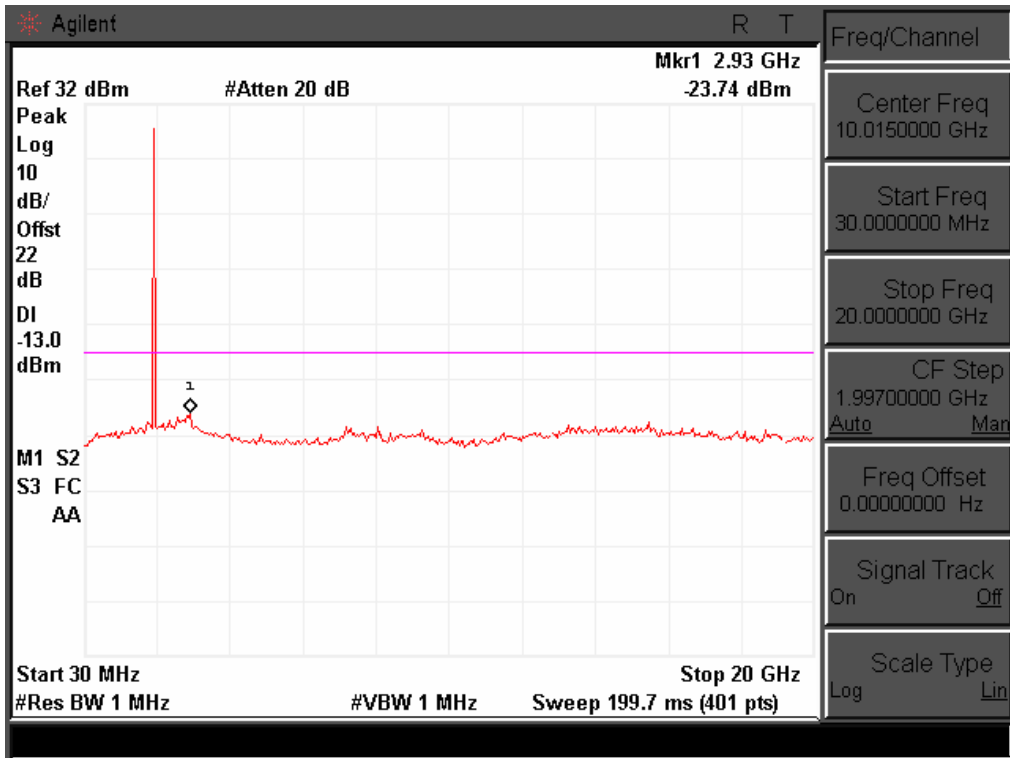





Test Item	Conducted spurious emissions, 30MHz - 20GHz
Test Mode	HSUPA 850
Test Date	2014-04-08

Channel 4132

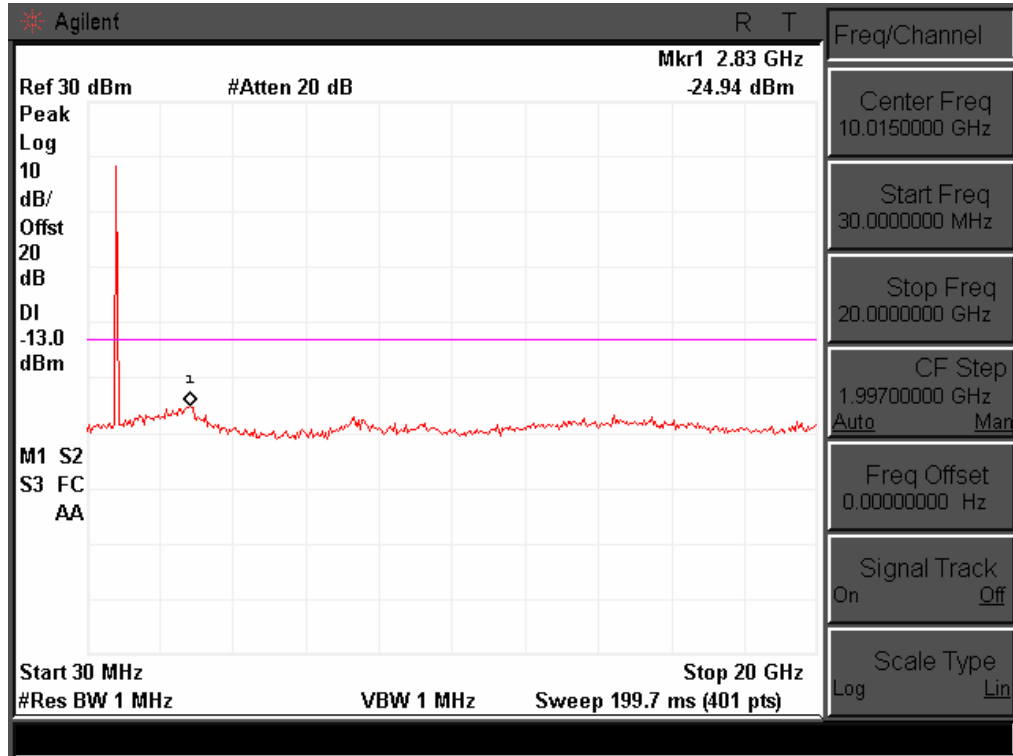



Channel 4183

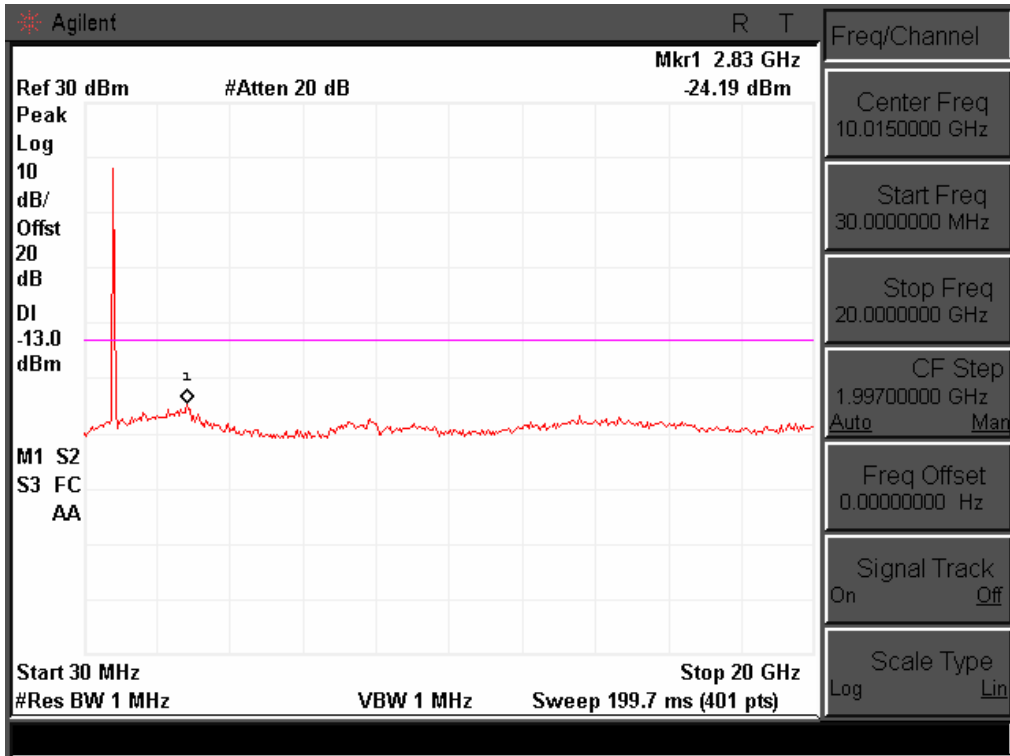

Channel 4233

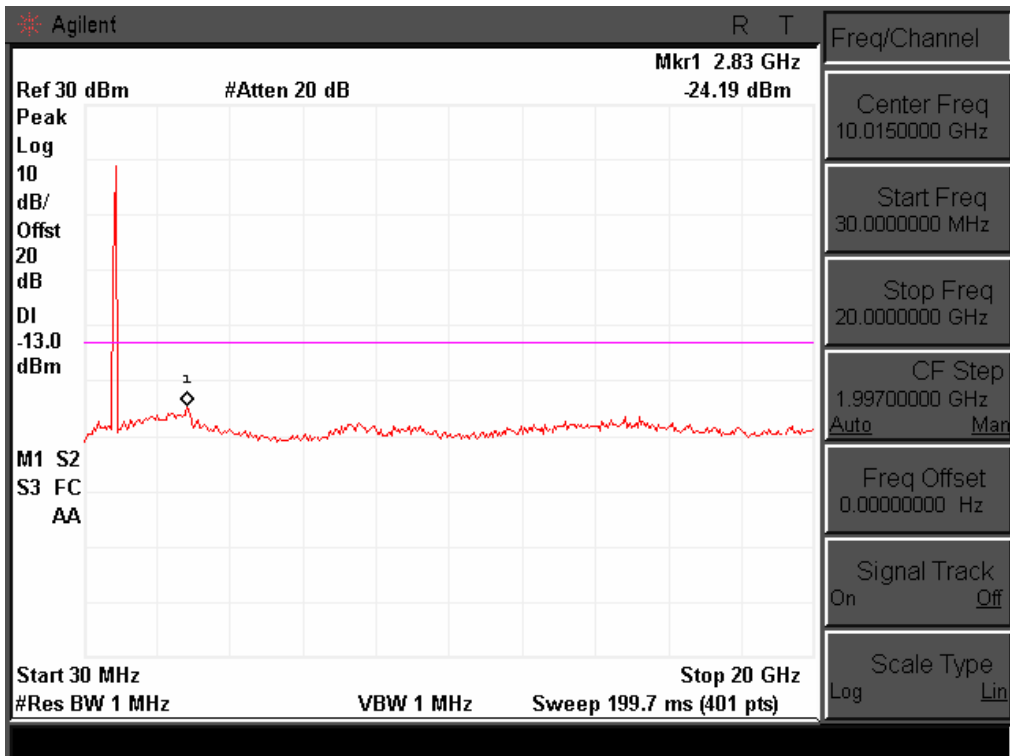



Test Item	Conducted spurious emissions, 30MHz - 20GHz
Test Mode	HSUPA 1900
Test Date	2014-04-08

Channel 9262

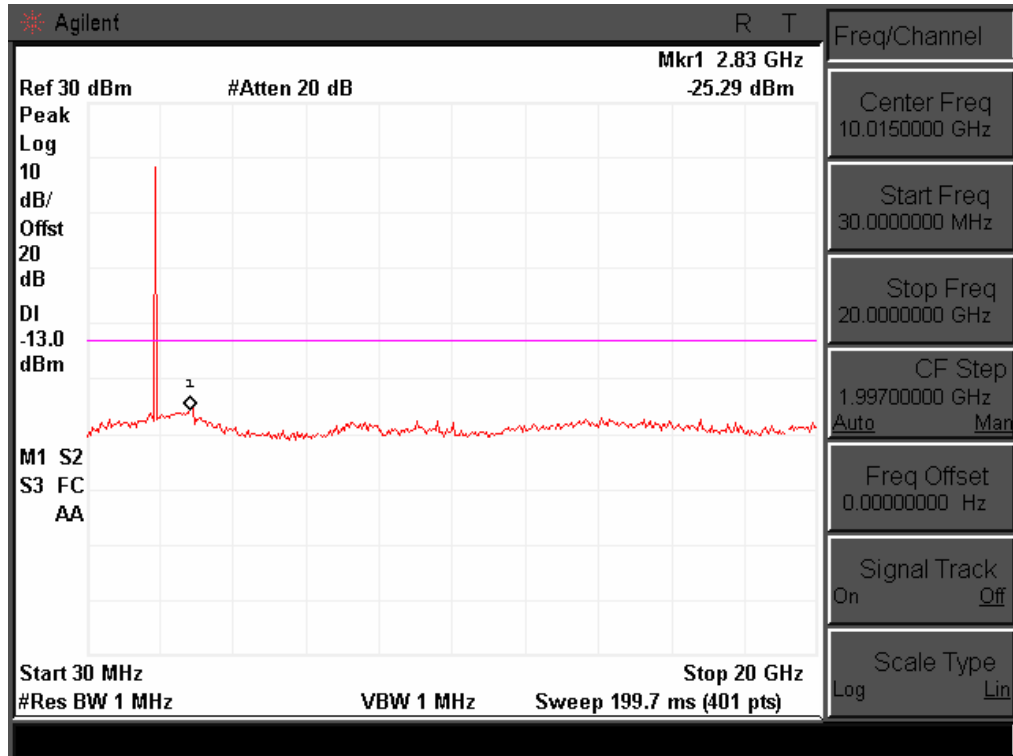



Channel 9400

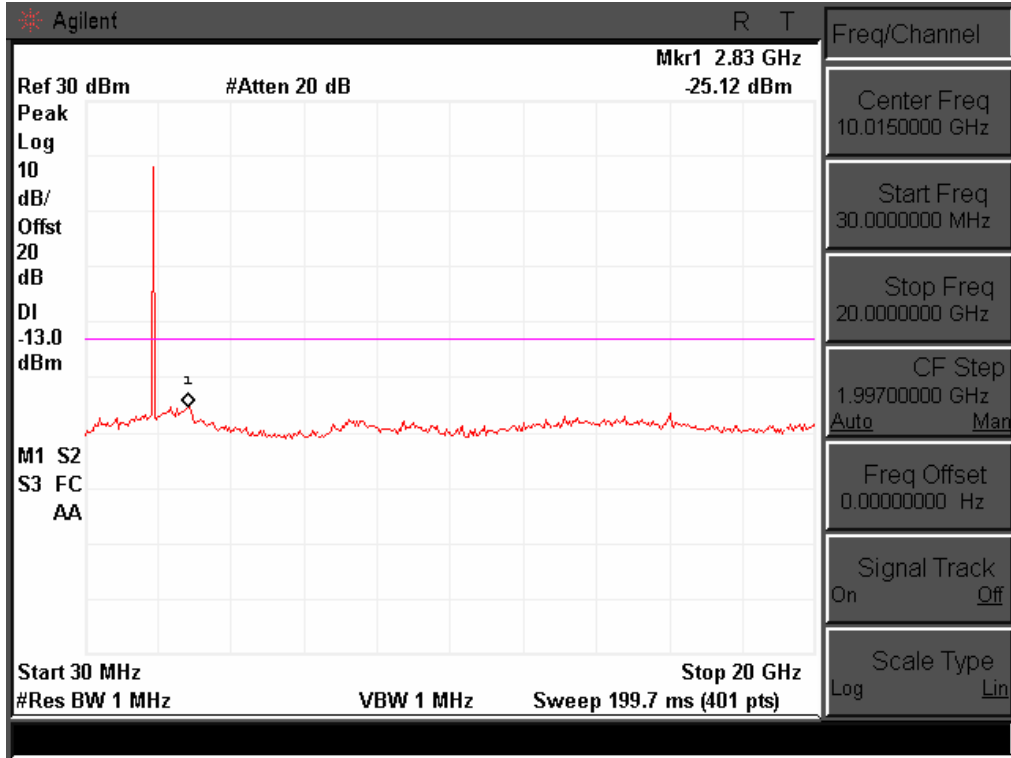

Channel 9538

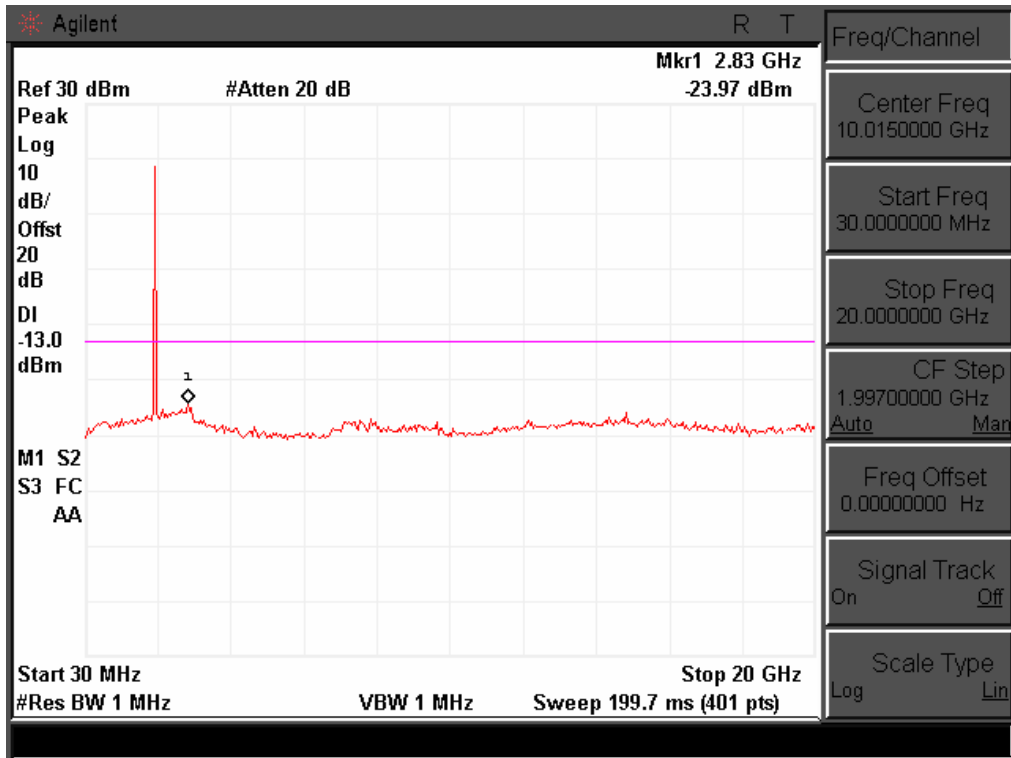



Test Item	Conducted spurious emissions, 30MHz - 20GHz
Test Mode	HSUPA 1700
Test Date	2014-04-08

Channel 1312

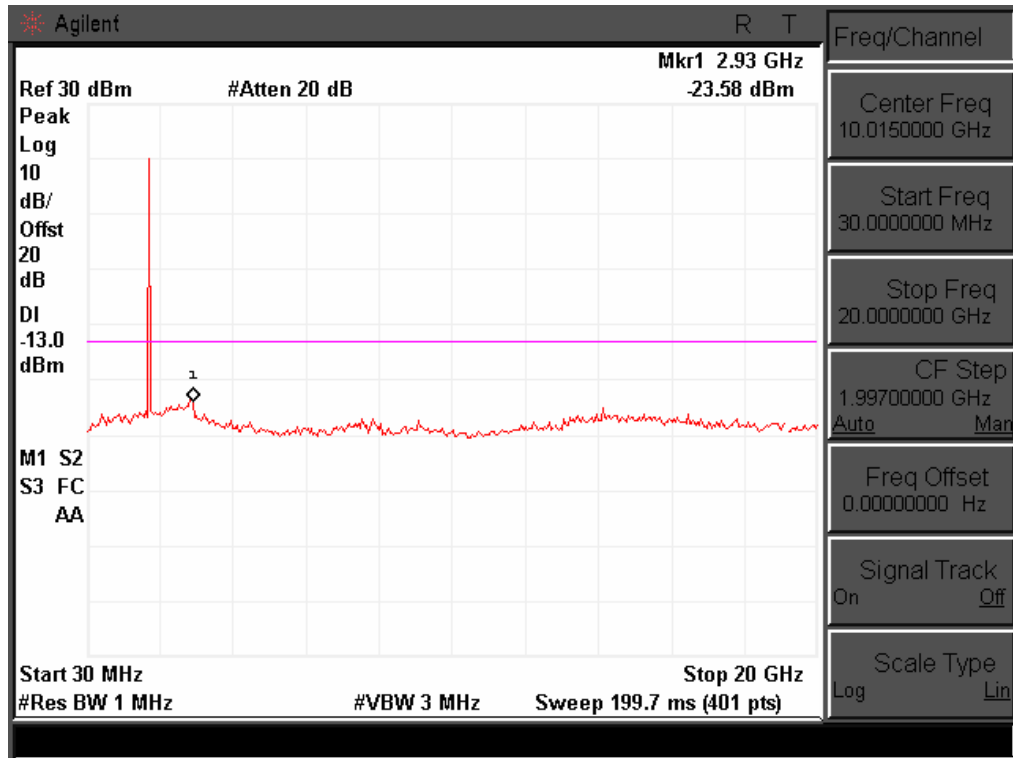



Channel 1413

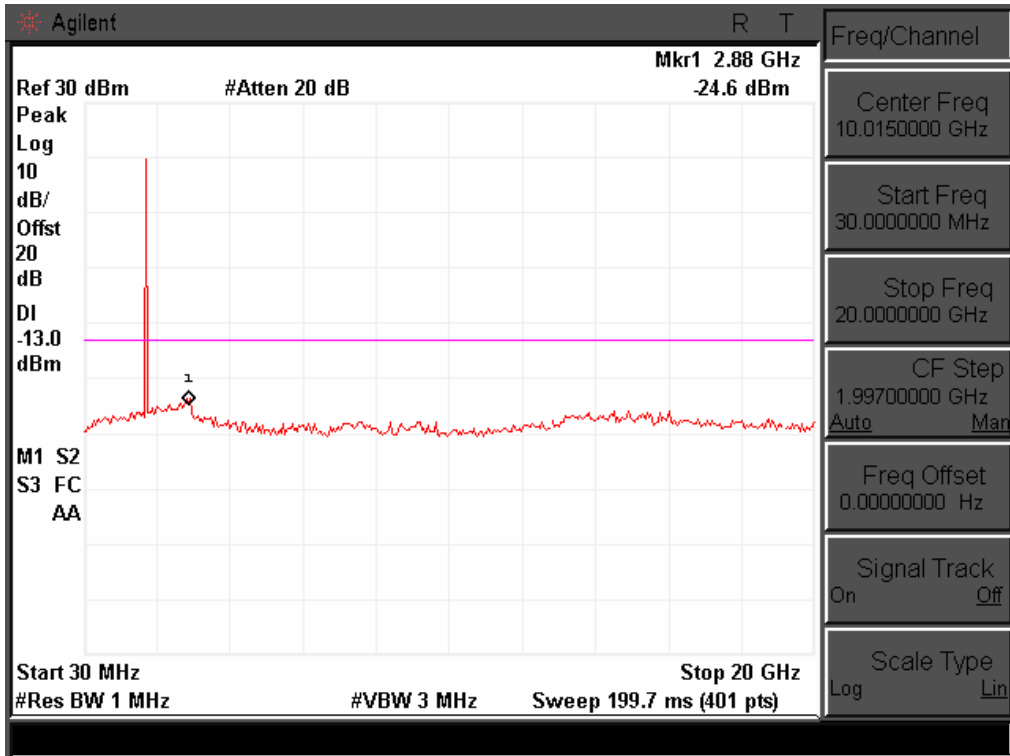

Channel 1513

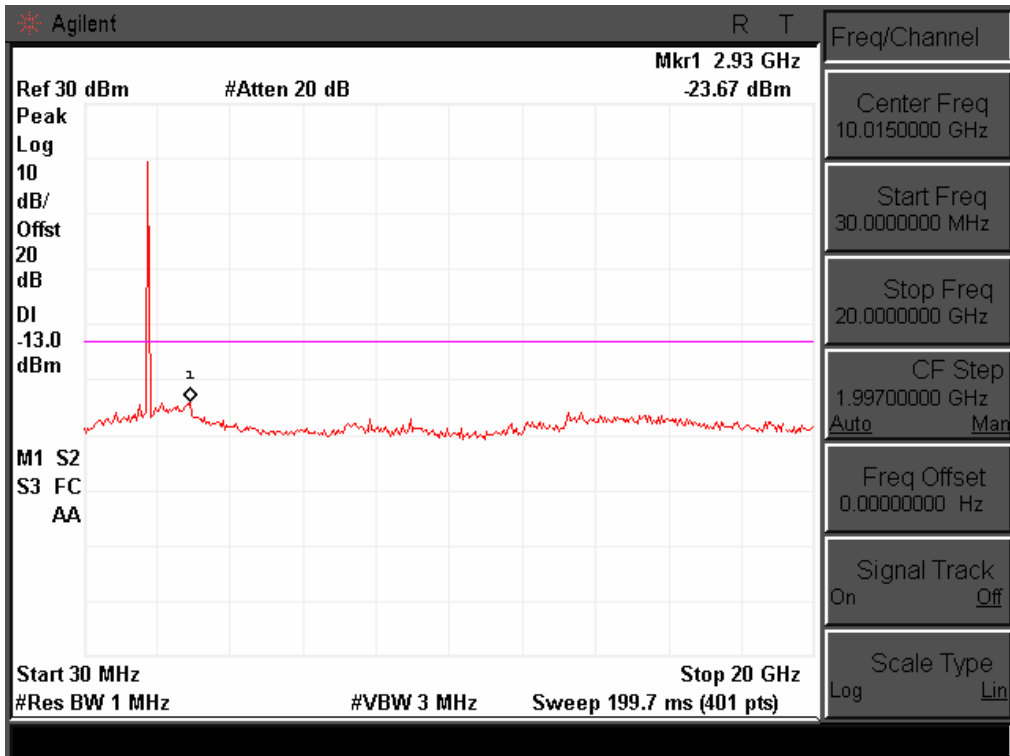



Test Item	Conducted spurious emissions, 30MHz - 20GHz
Test Mode	HSDPA 850
Test Date	2014-04-08

Channel 4132

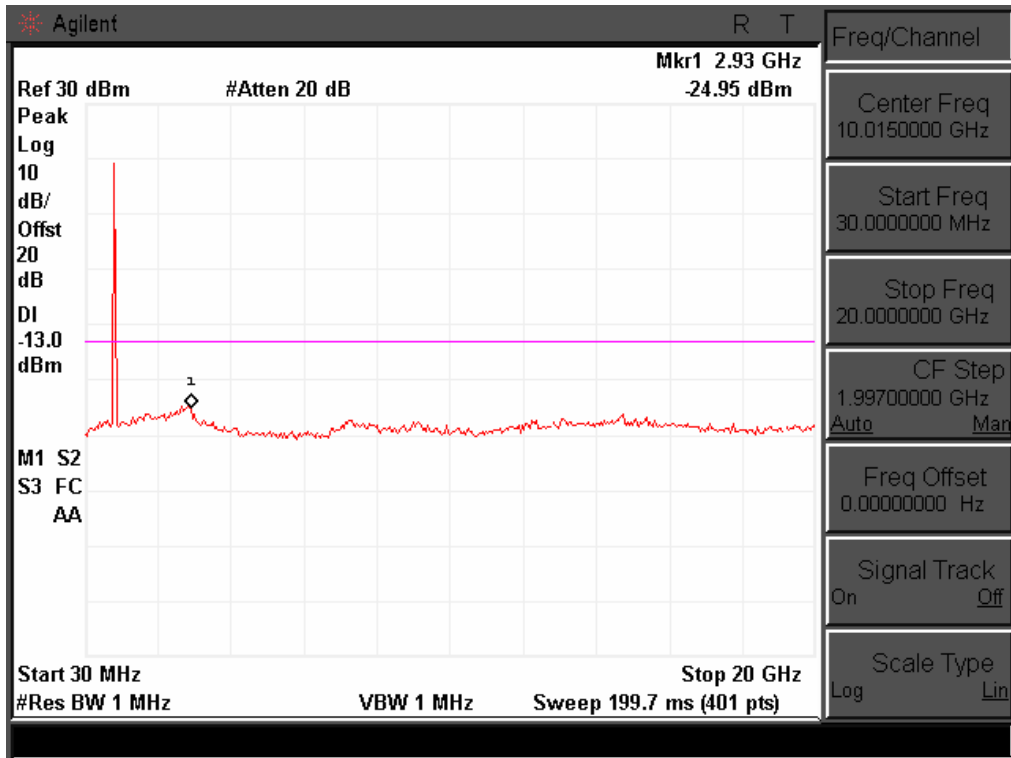



Channel 4183

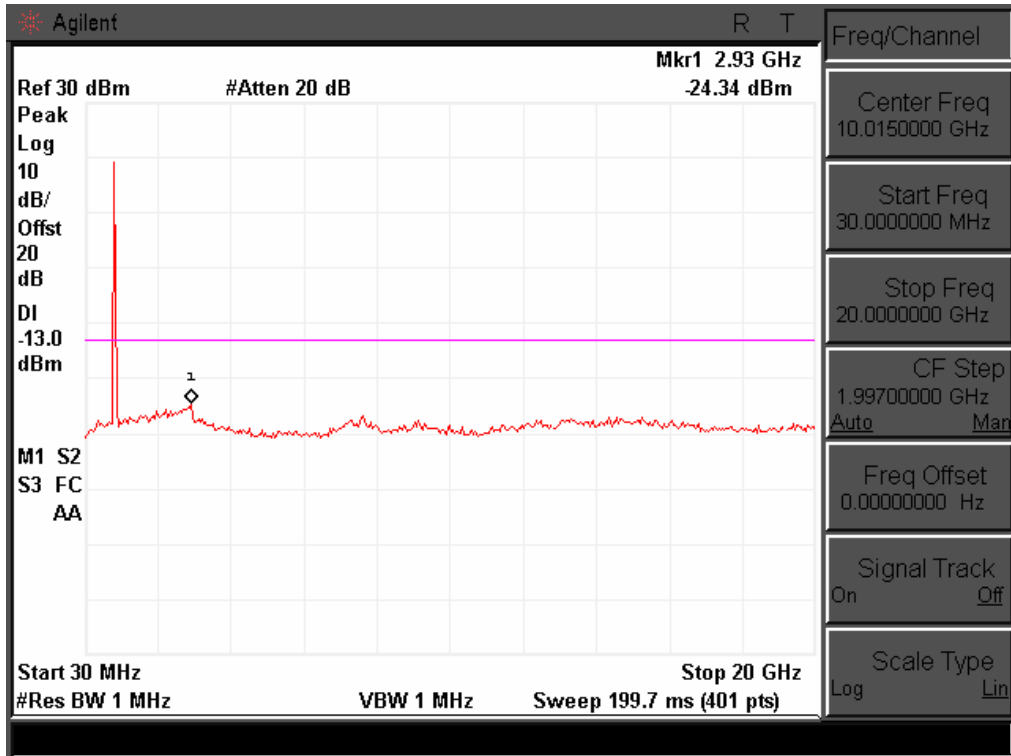

Channel 4233

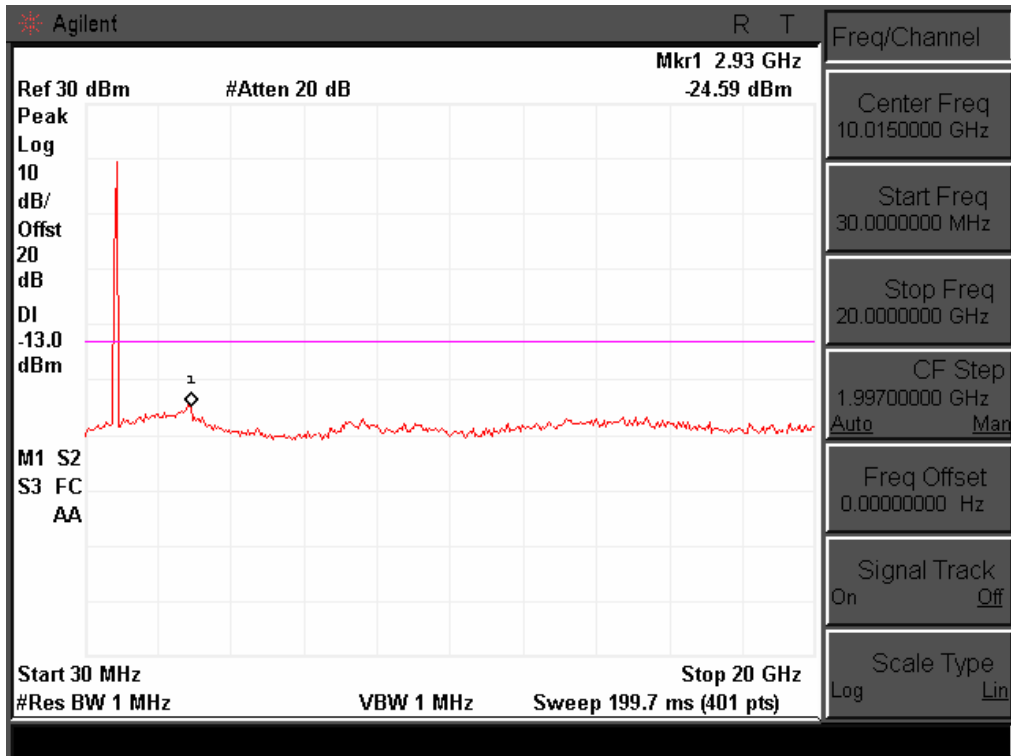





Test Item	Conducted spurious emissions, 30MHz - 20GHz
Test Mode	HSDPA 1900
Test Date	2014-04-08

Channel 9262

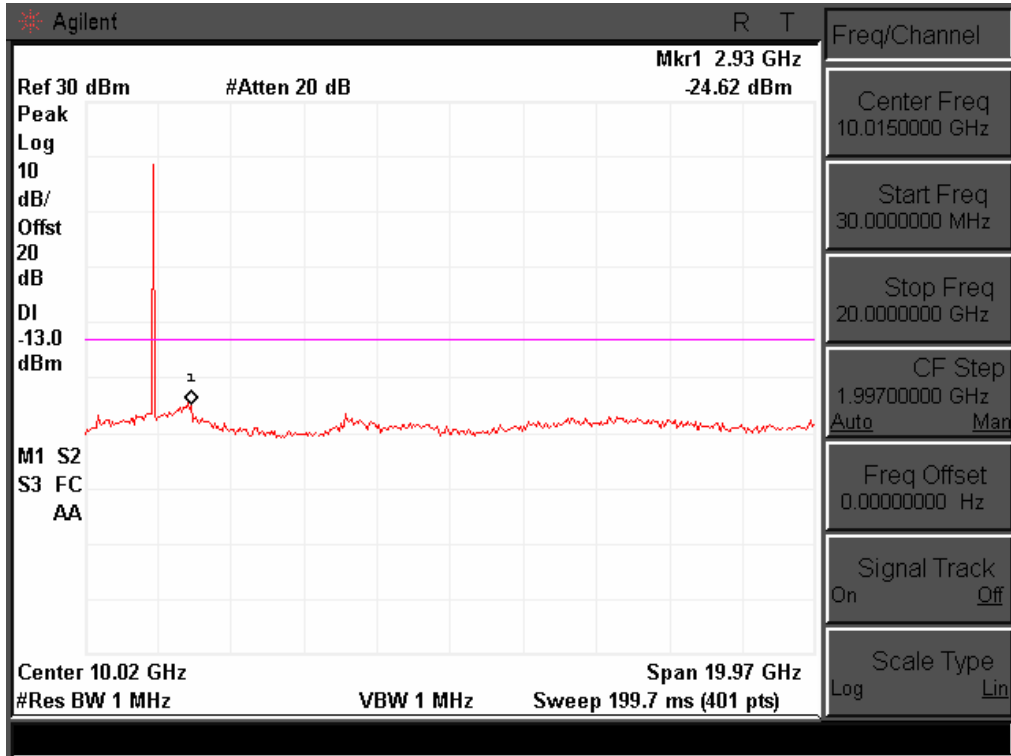



Channel 9400

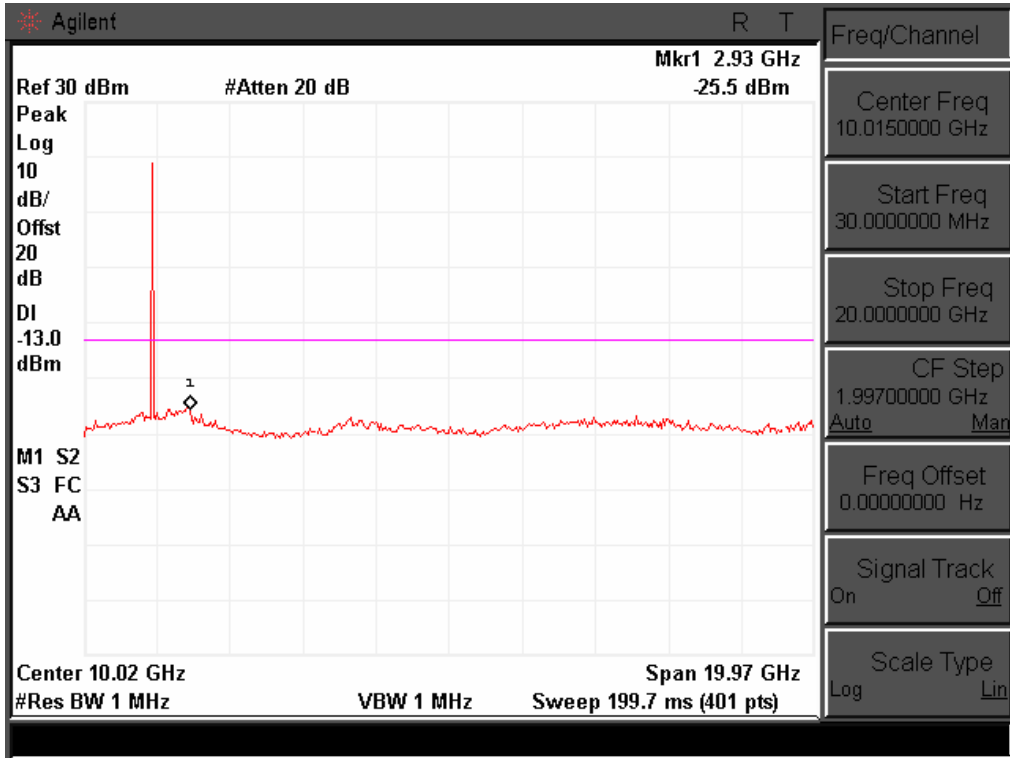

Channel 9538

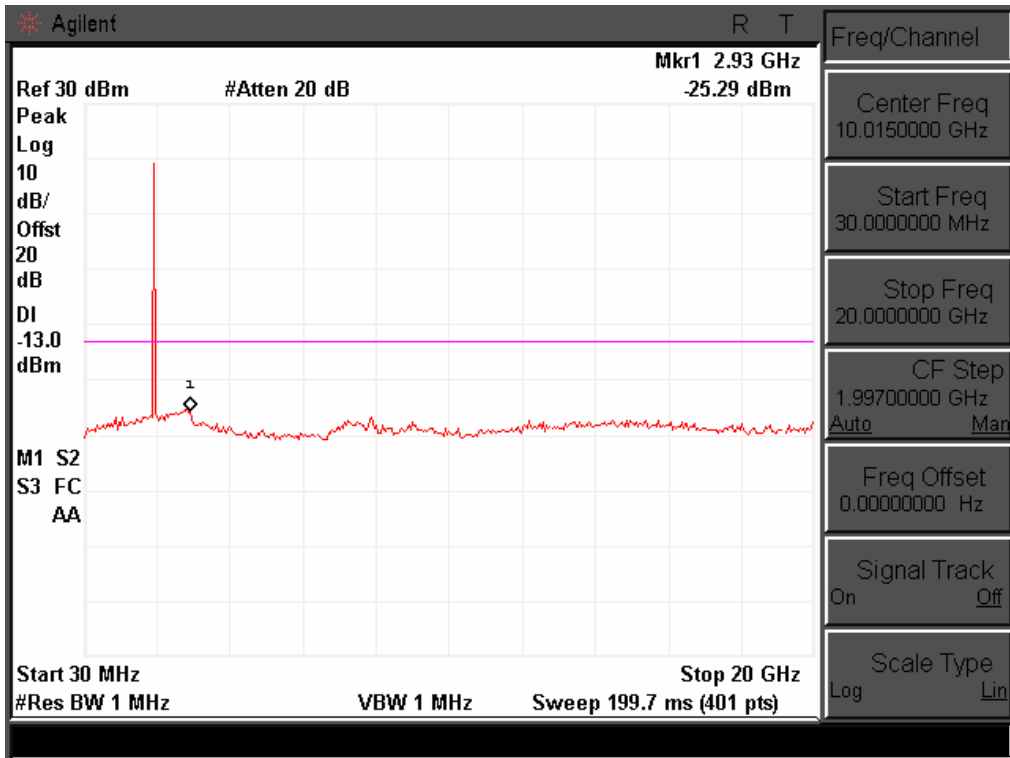



Test Item	Conducted spurious emissions, 30MHz - 20GHz
Test Mode	HSDPA 1700
Test Date	2014-04-08

Channel 1312

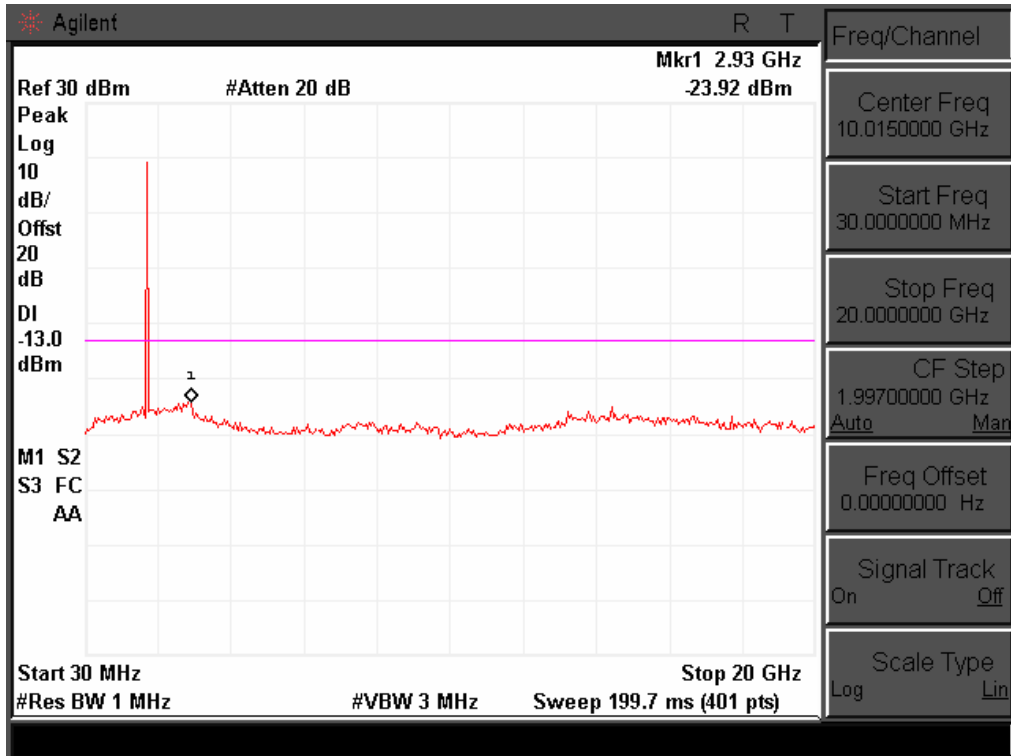



### Channel 1413

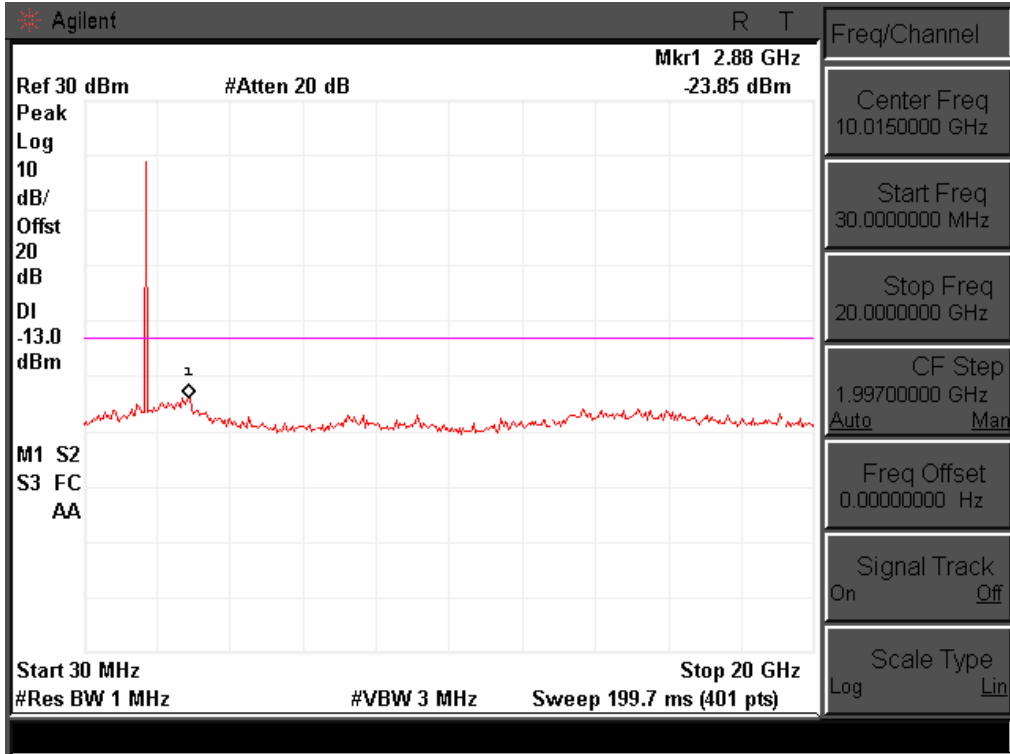

### Channel 1513

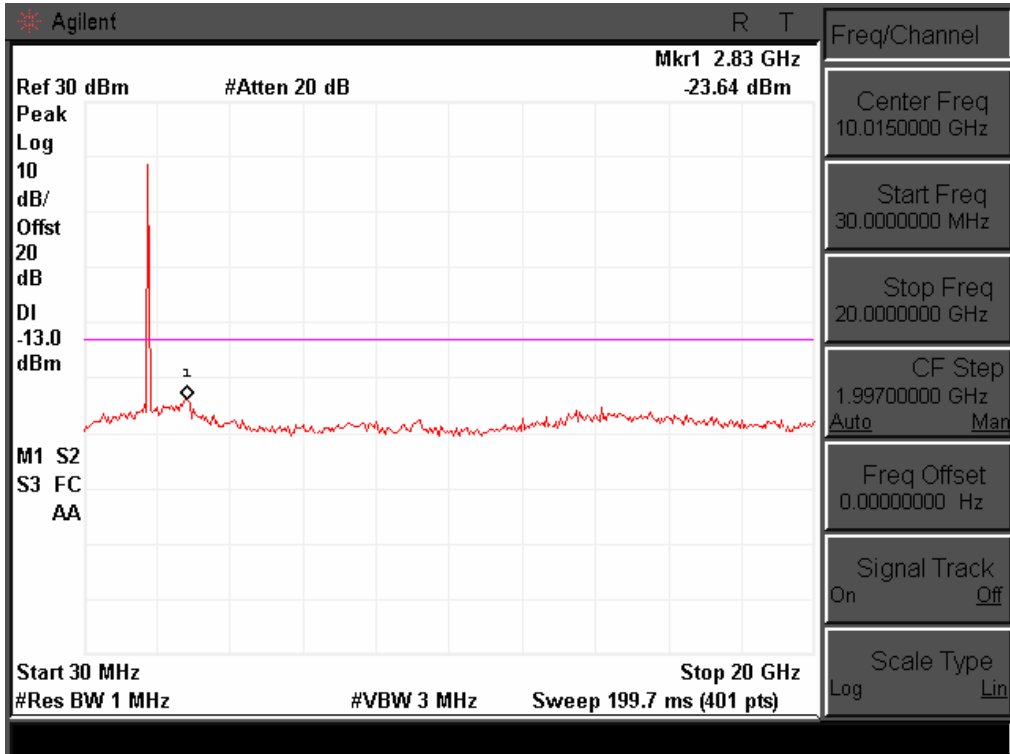



Test Item	Band Edge emissions
Test Mode	EDGE 850
Test Date	2014-04-08

Channel 128

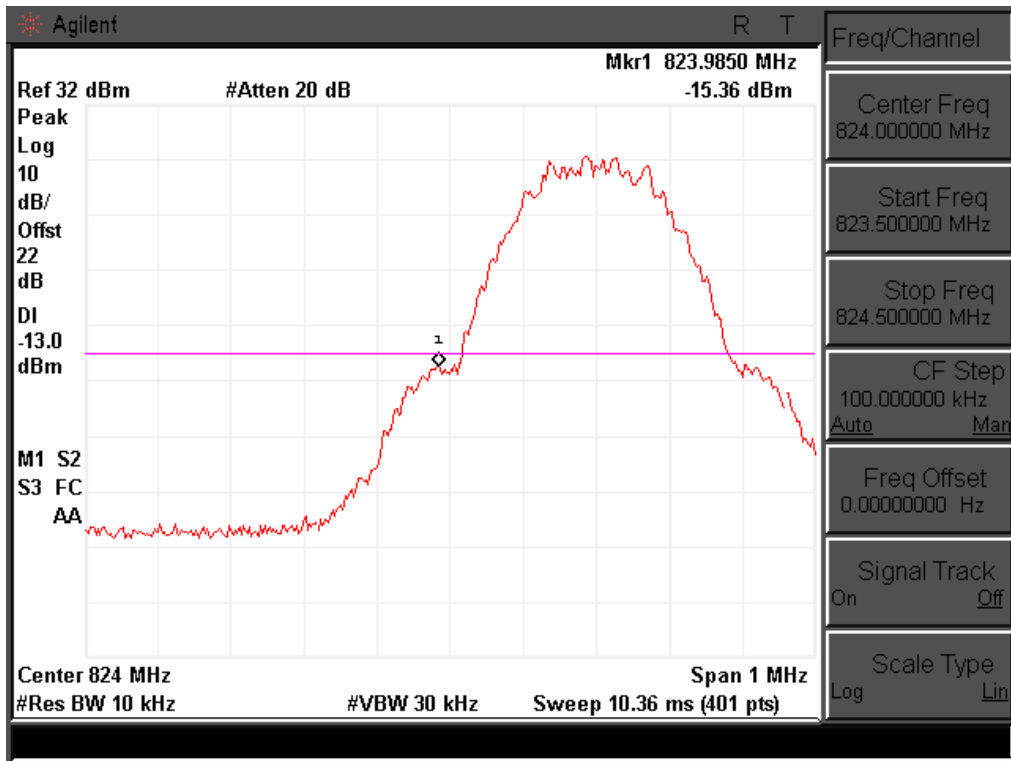

Channel 251

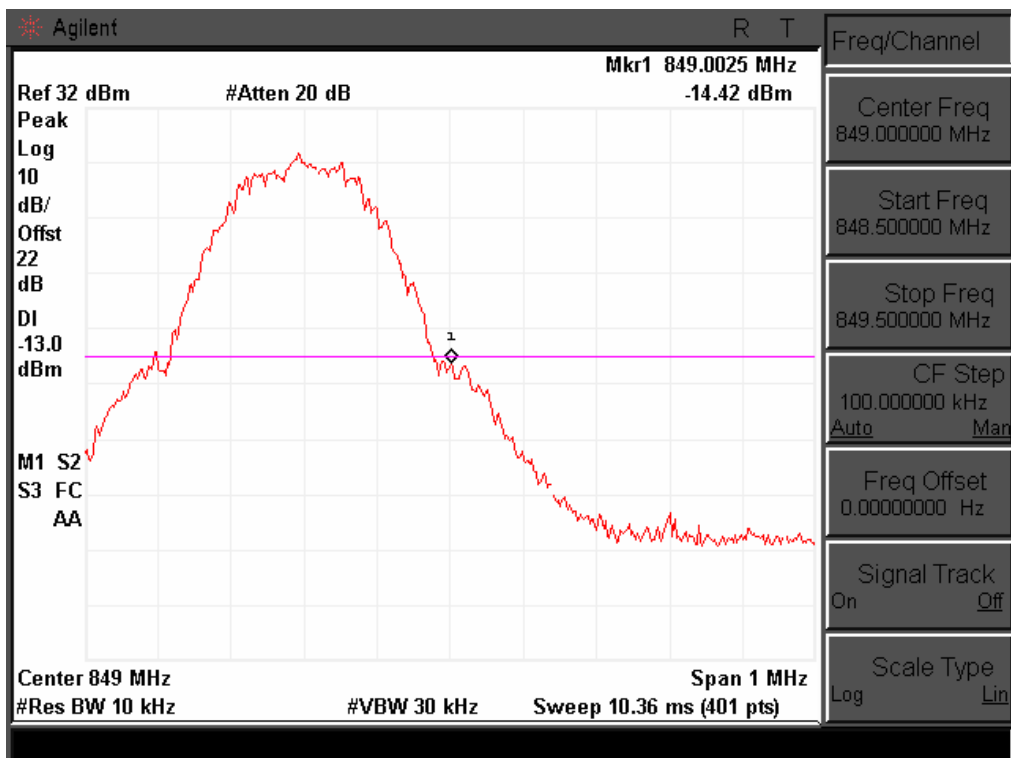



Test Item	Band Edge emissions
Test Mode	EDGE 1900
Test Date	2014-04-08

Channel 512

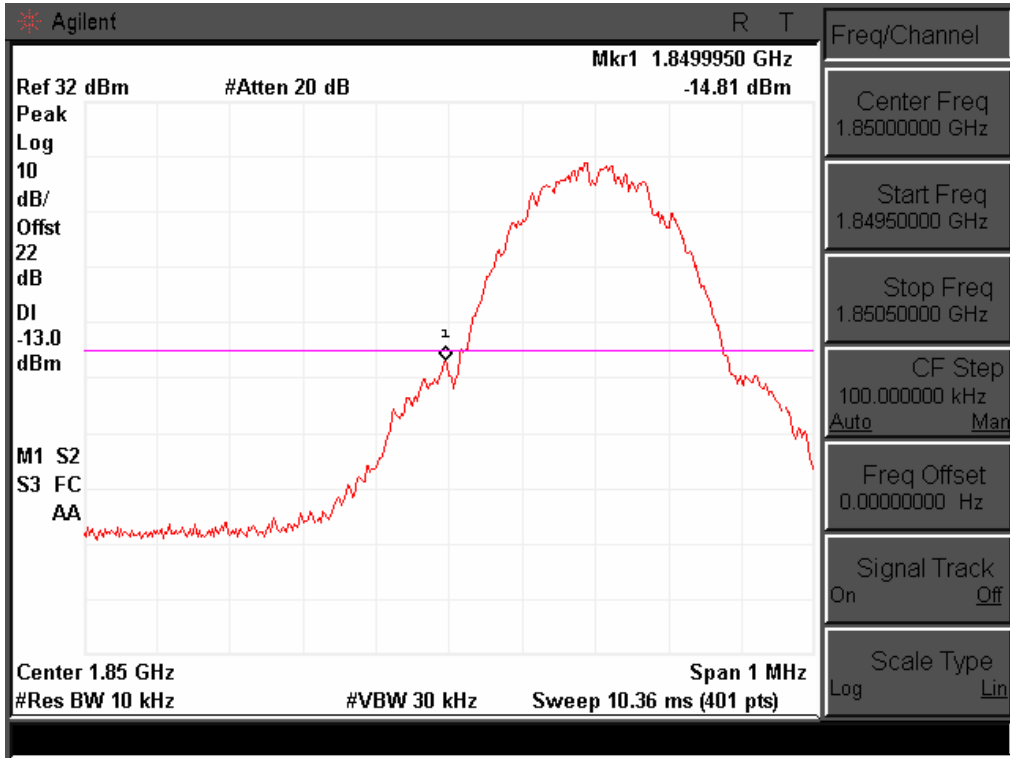

Channel 810

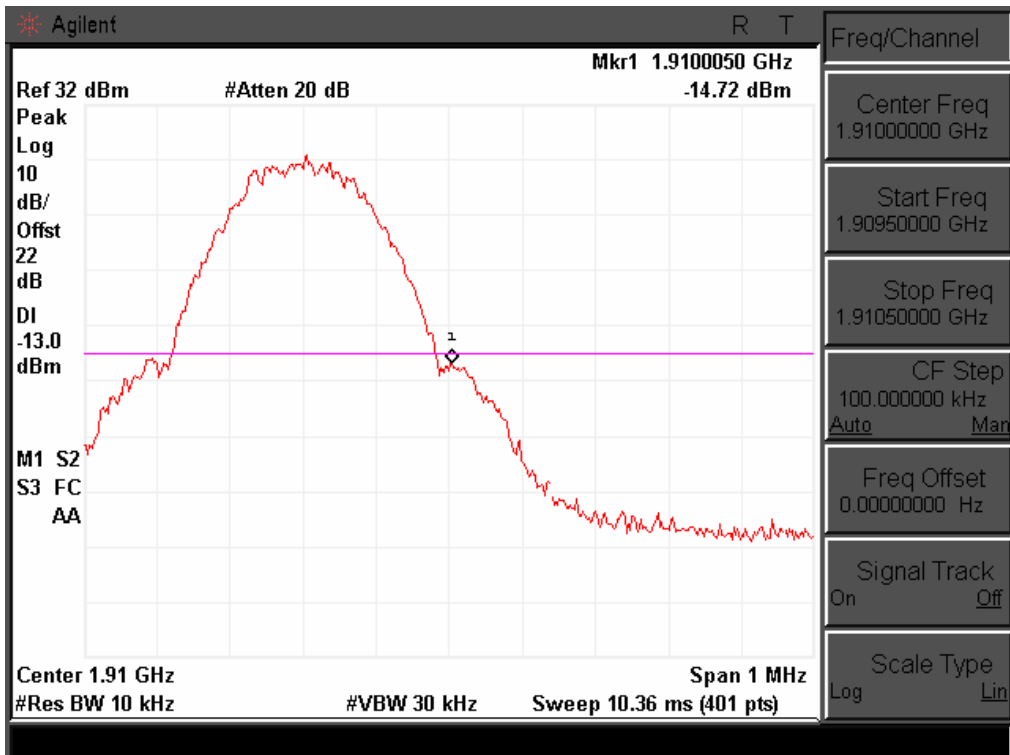



Test Item	Band Edge emissions
Test Mode	HSUPA 850
Test Date	2014-04-08

Channel 4132

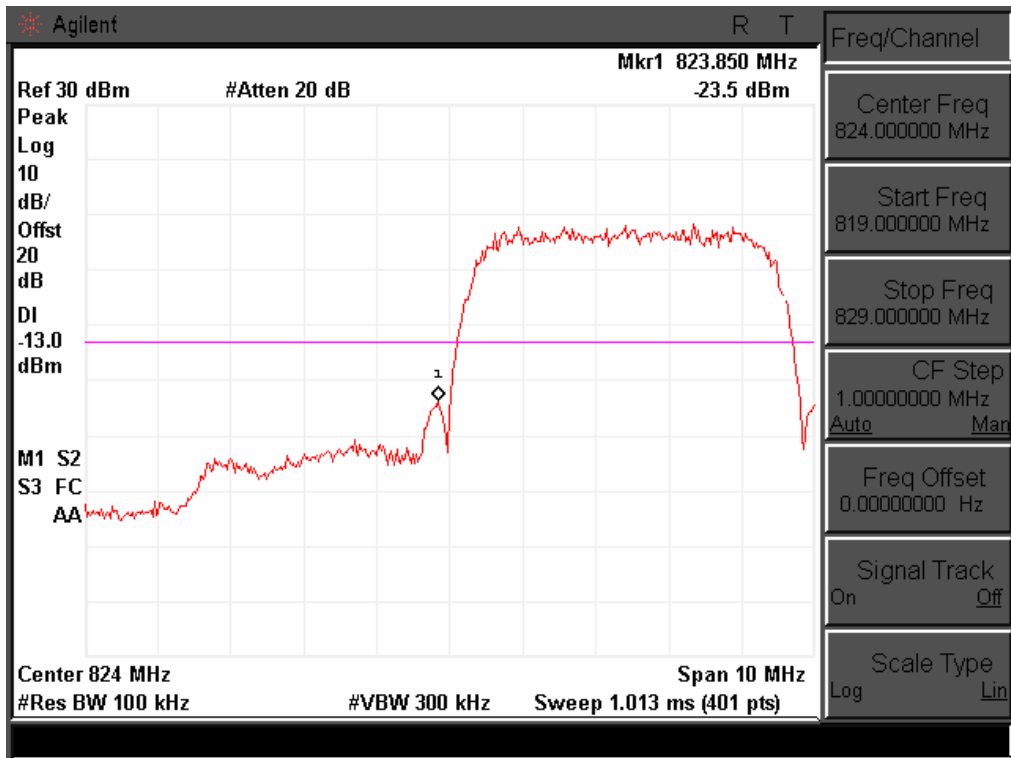

Channel 4233

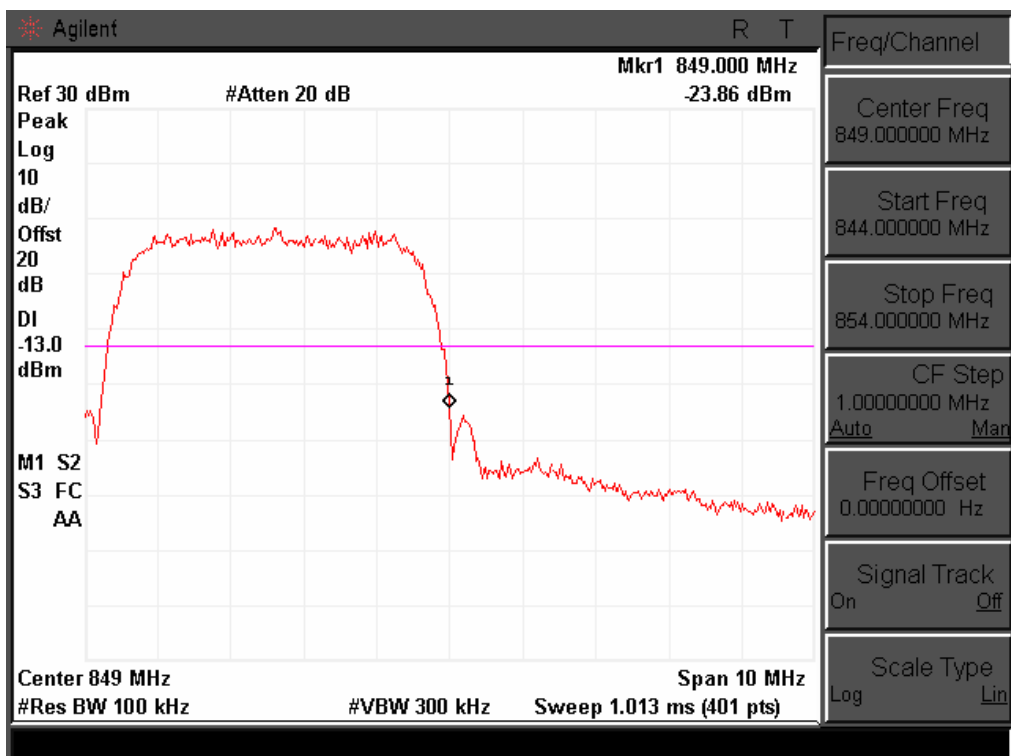



Test Item	Band Edge emissions
Test Mode	HSUPA 1900
Test Date	2014-04-08

Channel 9262

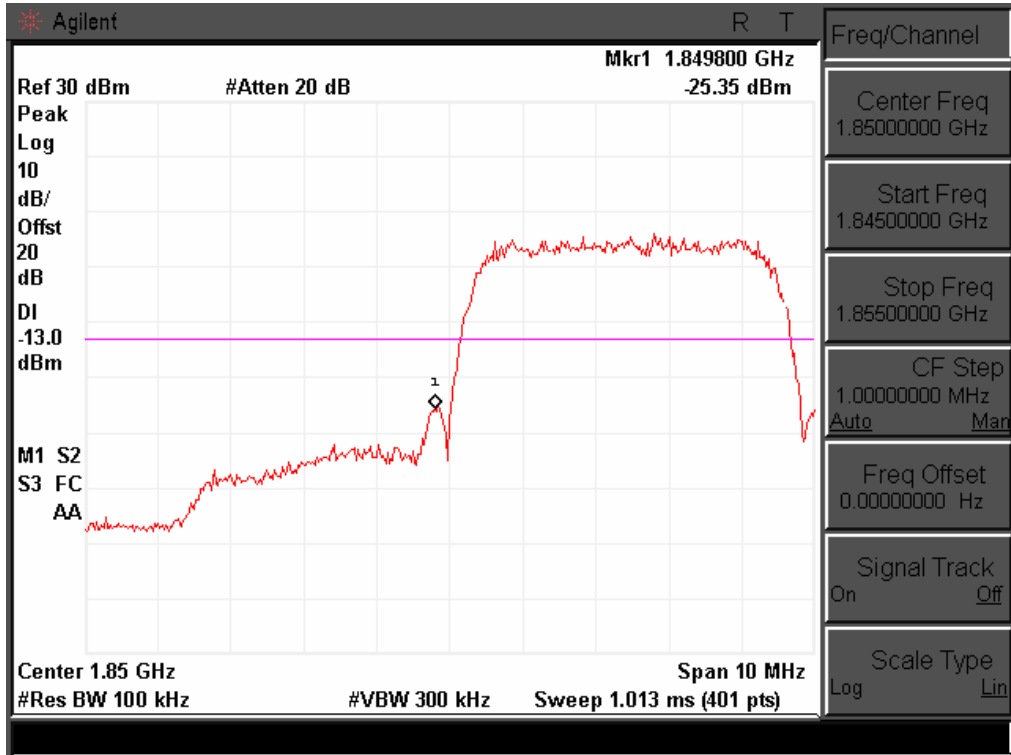

Channel 9538

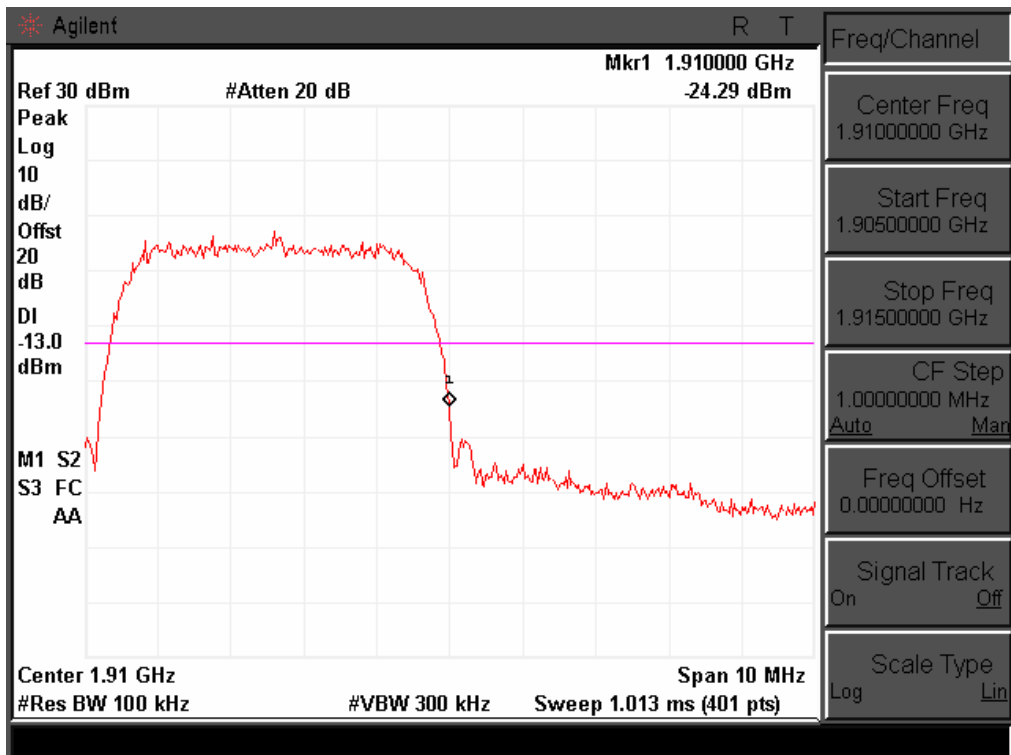





Test Item	Band Edge emissions
Test Mode	HSUPA 1700
Test Date	2014-04-08

Channel 1312

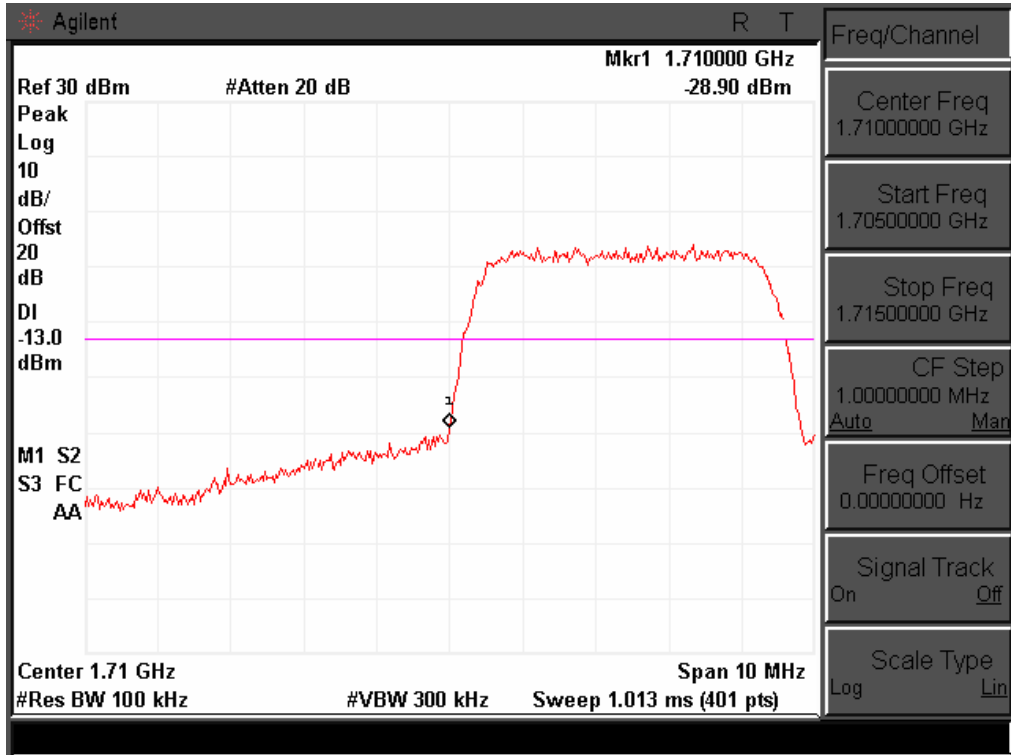

Channel 1513

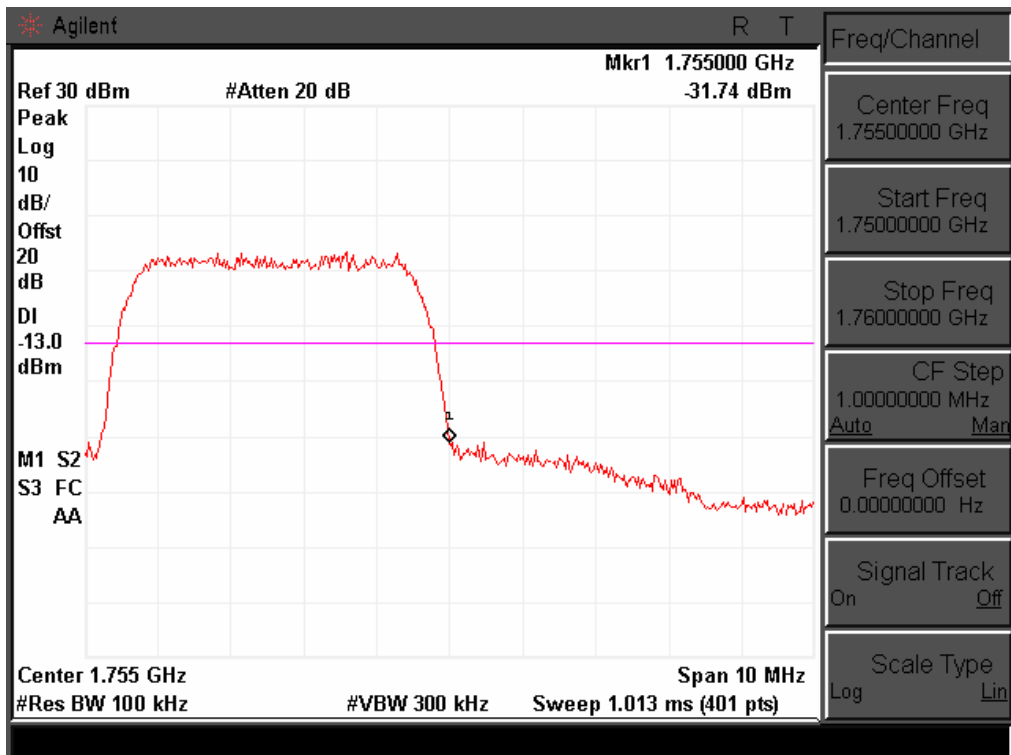



Test Item	Band Edge emissions
Test Mode	HSDPA 850
Test Date	2014-04-08

Channel 4132

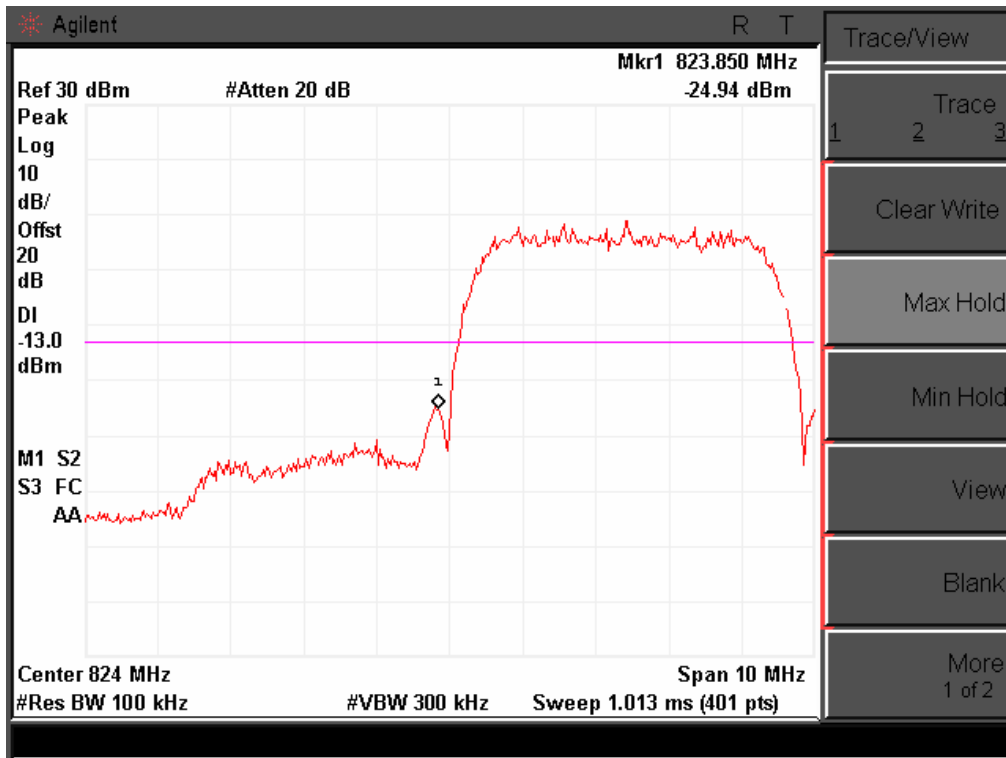

Channel 4233

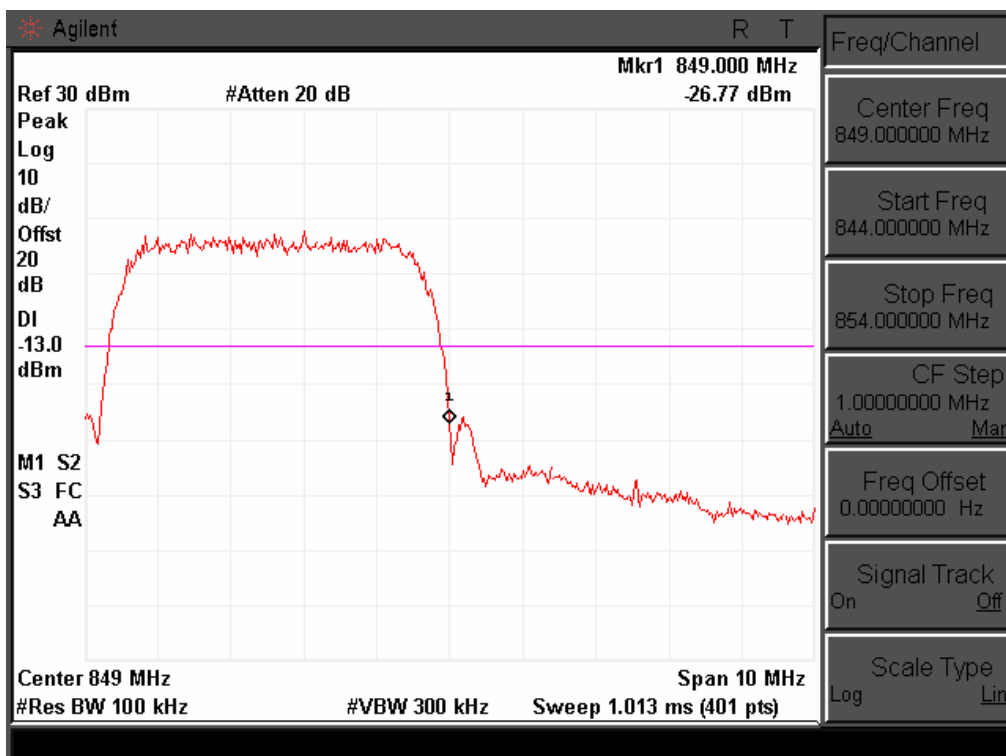



Test Item	Band Edge emissions
Test Mode	HSDPA 1900
Test Date	2014-04-08

Channel 9262

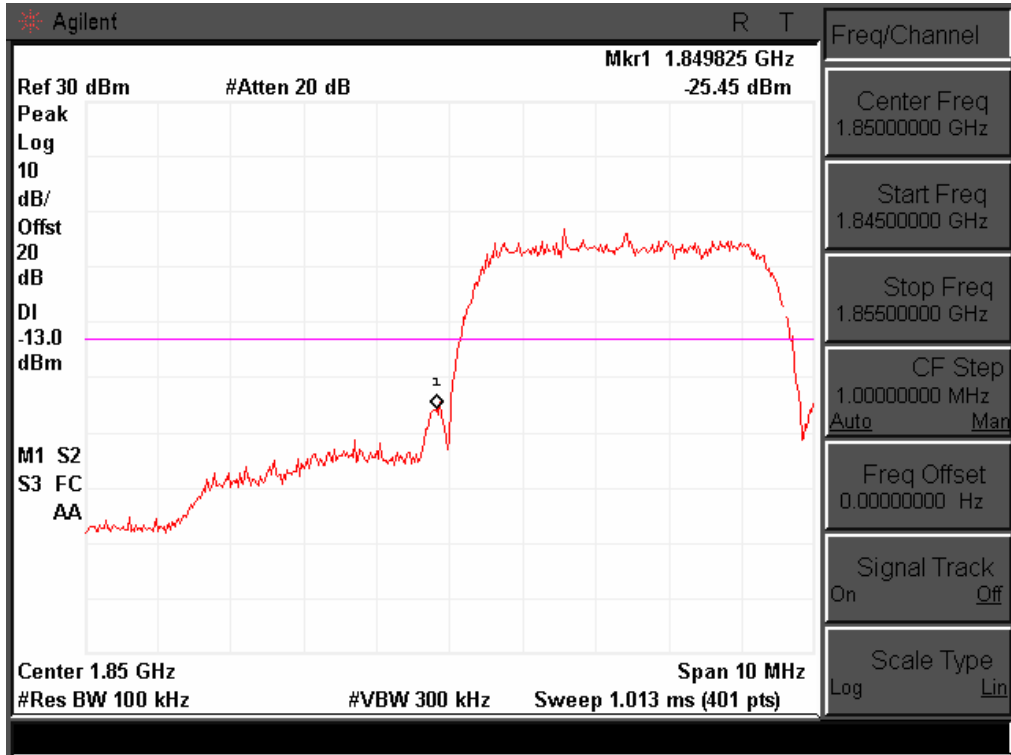

Channel 9538

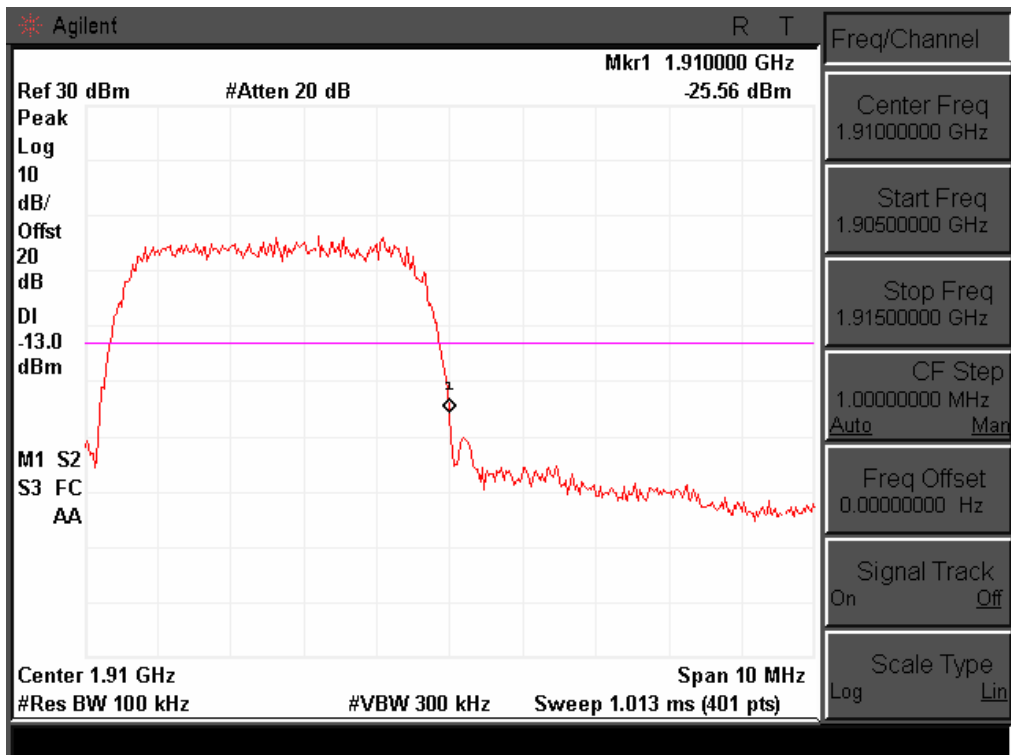



Test Item	Band Edge emissions
Test Mode	HSDPA 1700
Test Date	2014-04-08

Channel 1312

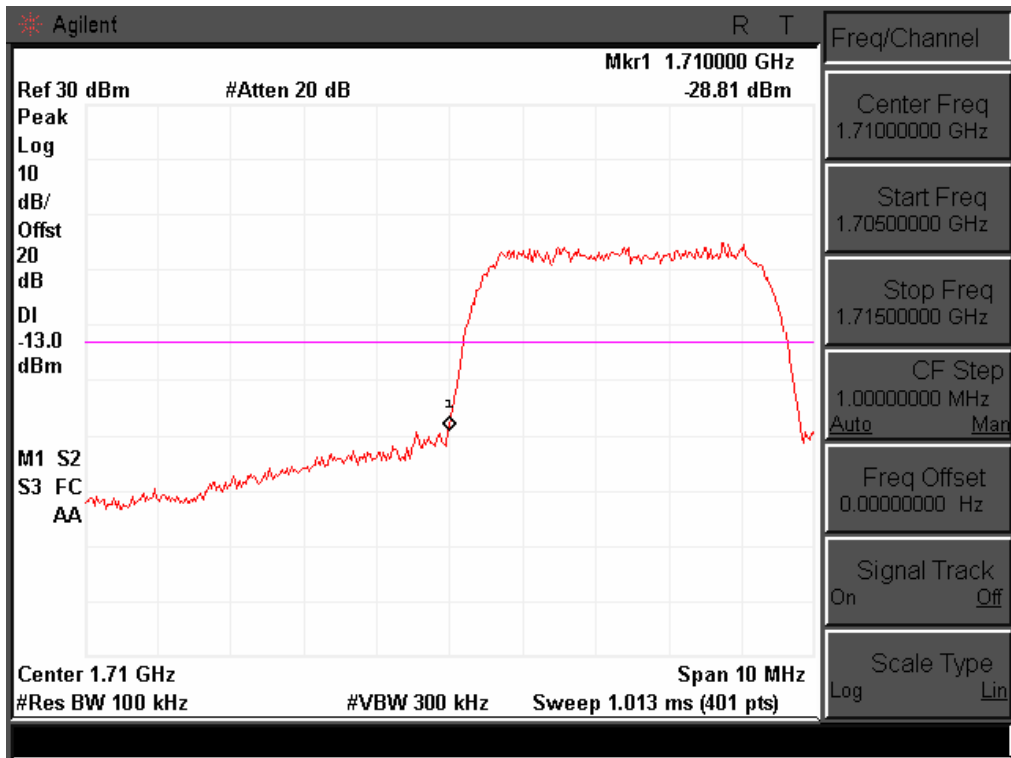

Channel 1513

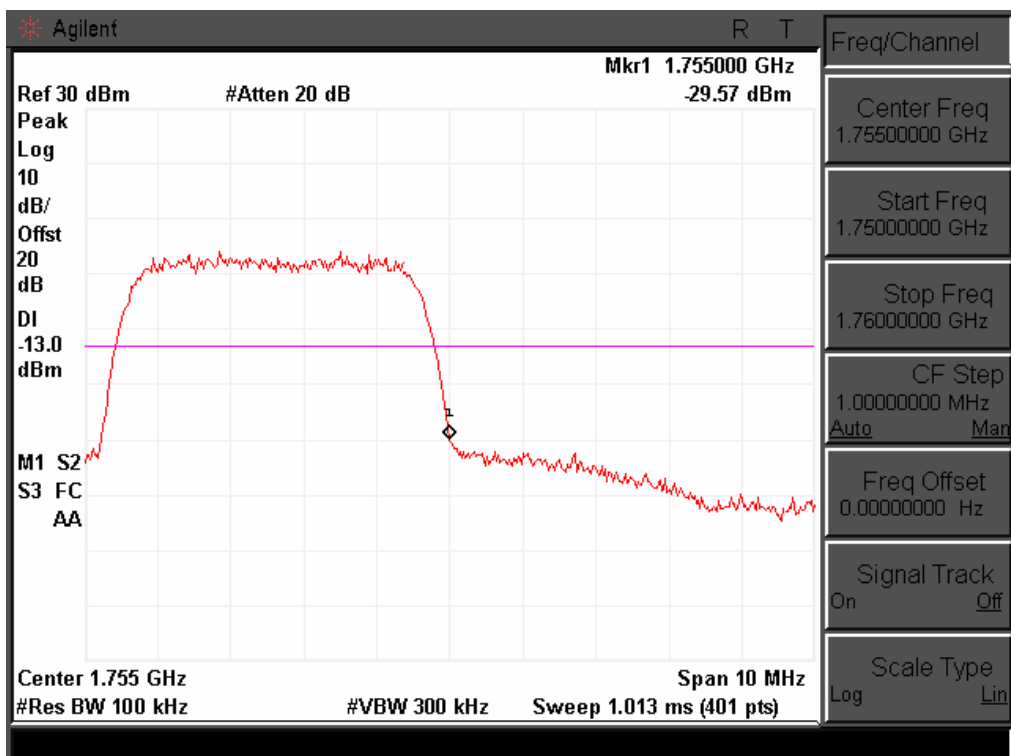



## 9. FREQUENCY STABILITY V.S. TEMPERATURE MEASUREMENT

### 9.1. Test Limit

According to FCC §2.1055, FCC §22.355, .FCC §24.235.

Frequency Tolerance: 2.5 ppm

### 9.2. Test Procedure

The equipment under test was connected to an external AC or DC power supply and input rated voltage. RF output was connected to a frequency counter or spectrum analyzer via feed through attenuators. The EUT was placed inside the temperature chamber. Set the spectrum analyzer RBW low enough to obtain the desired frequency resolution and measure EUT 20°C operating frequency as reference frequency. Turn EUT off and set the chamber temperature to -30°C. After the temperature stabilized for approximately 30 minutes recorded the frequency. Repeat step measure with 10°C increased per stage until the highest temperature of +50°C reached.

### 9.3. Test Setup Layout

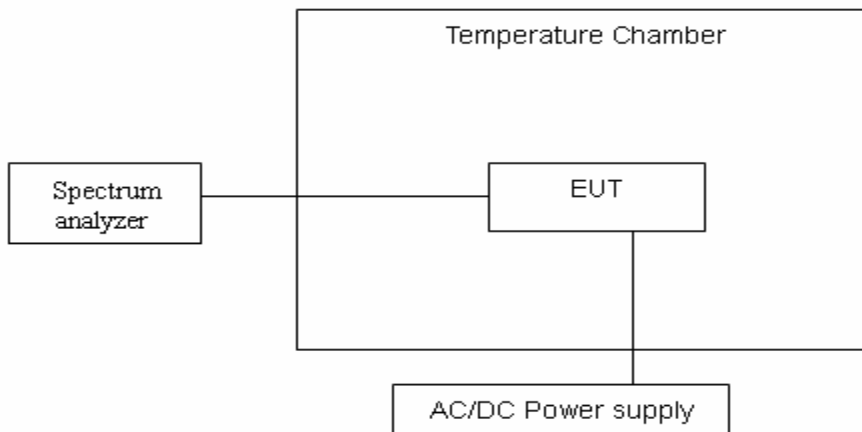

### 9.4. Measurement Equipment

Instrument/Ancillary	Model No.	Manufacturer	Serial No.	Calibration Date	Valid Date
Spectrum Analyzer	FSP40	R&S	100324	2014.03.10	2015.03.09
Temperature/ Humidity Meter	Zhicheng	ZC1-11	CEP-TH-002	2014.03.10	2015.03.09



9.5. Test Result and Data

Test Item	FREQUENCY STABILITY V.S. TEMPERATURE
Test Mode	EDGE 850 Channel 190
Test Date	2014-04-08

Reference Frequency: 836.6 MHz @ 230V				
Limit: +/- 2.5 ppm = 2090 Hz				
Power Supply Vac	Environment Temperature (°C)	Frequency (Hz)	Delta (Hz)	Limit (Hz)
230	50	83660044	44	2090
	40	83660051	51	
	30	83660024	24	
	20	83660000	0	
	10	83660024	24	
	0	83660008	8	
	-30	83660045	45	

Test Item	FREQUENCY STABILITY V.S. TEMPERATURE
Test Mode	EDGE 1900 Channel 661
Test Date	2014-04-08

Reference Frequency: 1880 MHz @ 230V				
Limit: ± 2.5 ppm = 4700 Hz				
Power Supply Vac	Environment Temperature (°C)	Frequency (Hz)	Delta (Hz)	Limit (Hz)
230	50	1880000015	15	4700
	40	1880000025	25	
	30	1880000051	51	
	20	1880000000	0	
	10	1880000023	23	
	0	1880000012	12	
	-30	1880000025	25	



Test Item	FREQUENCY STABILITY V.S. TEMPERATURE
Test Mode	HSUPA 850 Channel 4183
Test Date	2014-04-08

Reference Frequency: HSUPA Mid Channel 836.6 MHz @ 230V				
Limit: +/- 2.5 ppm = 2090 Hz				
Power Supply Vac	Environment Temperature (°C)	Frequency (Hz)	Delta (Hz)	Limit (Hz)
230	50	836600034	34	2090
	40	836600041	41	
	30	836600034	34	
	20	836600000	0	
	10	836600045	45	
	0	836600011	11	
	-30	836600018	18	

Test Item	FREQUENCY STABILITY V.S. TEMPERATURE
Test Mode	HSUPA 1900 Channel 9400
Test Date	2014-04-08

Reference Frequency: HSUPA Mid Channel 1880 MHz @ 230V				
Limit: ± 2.5 ppm = 4700 Hz				
Power Supply Vac	Environment Temperature (°C)	Frequency (Hz)	Delta (Hz)	Limit (Hz)
230	50	1880000034	34	4700
	40	1880000045	45	
	30	1880000012	12	
	20	1880000000	0	
	10	1880000045	45	
	0	1880000045	45	
	-30	1880000012	12	



Test Item	FREQUENCY STABILITY V.S. TEMPERATURE
Test Mode	HSUPA 1700 Channel 1413
Test Date	2014-04-08

Reference Frequency: HSUPA Mid Channel 1732.5 MHz @ 230V				
Limit: +/- 2.5 ppm = 4331 Hz				
Power Supply Vac	Environment Temperature (°C)	Frequency (Hz)	Delta (Hz)	Limit (Hz)
230	50	1732500014	14	4331
	40	1732500045	45	
	30	1732500023	23	
	20	1732500000	0	
	10	1732500015	15	
	0	1732500010	10	
	-30	1732500014	14	

Test Item	FREQUENCY STABILITY V.S. TEMPERATURE
Test Mode	HSDPA 850 Channel 4183
Test Date	2014-04-08

Reference Frequency: HSDPA Mid Channel 836.6 MHz @230V				
Limit: +/- 2.5 ppm = 2090 Hz				
Power Supply Vac	Environment Temperature (°C)	Frequency (Hz)	Delta (Hz)	Limit (Hz)
230	50	836600020	20	2090
	40	836600043	43	
	30	836600020	20	
	20	836600000	0	
	10	836600012	12	
	0	836600045	45	
	-30	836600056	56	





Test Item	FREQUENCY STABILITY V.S. TEMPERATURE
Test Mode	HSDPA 1900 Channel 9400
Test Date	2014-04-08

Reference Frequency: HSDPA Mid Channel 1880 MHz @ 230V				
Limit: ± 2.5 ppm = 4700 Hz				
Power Supply Vac	Environment Temperature (°C)	Frequency (Hz)	Delta (Hz)	Limit (Hz)
230	50	1880000034	34	4700
	40	1880000052	52	
	30	1880000024	24	
	20	1880000000	0	
	10	1880000015	15	
	0	1880000022	22	
	-30	1880000068	68	

Test Item	FREQUENCY STABILITY V.S. TEMPERATURE
Test Mode	HSDPA 1700 Channel 1413
Test Date	2014-04-08

Reference Frequency: HSUPA Mid Channel 1732.5 MHz @ 230V				
Limit: ± 2.5 ppm = 4331 Hz				
Power Supply Vac	Environment Temperature (°C)	Frequency (Hz)	Delta (Hz)	Limit (Hz)
230	50	1732500045	45	4331
	40	1732500023	23	
	30	1732500056	56	
	20	1732500000	0	
	10	1732500044	44	
	0	1732500021	21	
	-30	1732500045	45	



# 1. REQUENCY STABILITY V.S. VOLTAGE MEASUREMENT

## 1.1. Test Limit

According to FCC §2.1055, FCC §22.355, .FCC §24.235.

## 1.2. Test Procedure

Set chamber temperature to 20°C. Use a variable AC power supply / DC power source to power the EUT and set the voltage to rated voltage. Set the spectrum analyzer RBW low enough to obtain the desired frequency resolution and recorded the frequency.

Reduce the input voltage to specify extreme voltage variation ( $\pm 10\%$ ) and endpoint, record the maximum frequency change.

## 1.3. Test Setup Layout

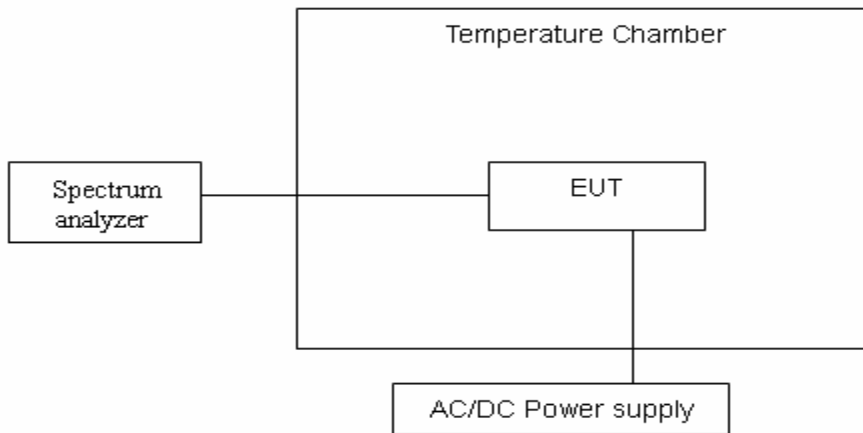

## 1.4. Measurement Equipment

Instrument/Ancillary	Model No.	Manufacturer	Serial No.	Calibration Date	Valid Date
Spectrum Analyzer	FSP40	R&S	100324	2013.03.10	2014.03.09
Temperature/ Humidity Meter	Zhicheng	ZC1-11	CEP-TH-002	2013.03.10	2014.03.09



1.5. Test Result and Data

Test Item	REQUENCY STABILITY V.S. VOLTAGE
Test Mode	EDGE 850 Channel 190
Test Date	2014-04-08

Reference Frequency: 836.6 MHz @ 20°C				
Limit: ± 2.5 ppm = 2090Hz				
Power Supply Vac	Environment Temperature (°C)	Frequency (Hz)	Delta (Hz)	Limit (Hz)
253	20	836599966	34	2090
230		836600000	0	
207		836599987	13	

Test Item	REQUENCY STABILITY V.S. VOLTAGE
Test Mode	EDGE 1900 Channel 661
Test Date	2014-04-08

Reference Frequency: 1880 MHz @ 20°C				
Limit: ± 2.5 ppm = 4700 Hz				
Power Supply Vac	Environment Temperature (°C)	Frequency (Hz)	Delta (Hz)	Limit (Hz)
253	20	1879999976	24	4700
230		1880000000	0	
207		1879999945	55	



Test Item	REQUENCY STABILITY V.S. VOLTAGE
Test Mode	HSUPA 850 Channel 4183
Test Date	2014-04-08

Reference Frequency: HSUPA Mid Channel 836.6 MHz @ 20°C				
Limit: ± 2.5 ppm = 2090Hz				
Power Supply Vac	Environment Temperature (°C)	Frequency (Hz)	Delta (Hz)	Limit (Hz)
253	20	836599979	21	2090
230		836600000	0	
207		836599967	33	

Test Item	REQUENCY STABILITY V.S. VOLTAGE
Test Mode	HSUPA 1900 Channel 9400
Test Date	2014-04-08

Reference Frequency: HSUPA Mid Channel 1880 MHz @ 20°C				
Limit: ± 2.5 ppm = 4700 Hz				
Power Supply Vac	Environment Temperature (°C)	Frequency (Hz)	Delta (Hz)	Limit (Hz)
253	20	1879999956	44	4700
230		1880000000	0	
207		1879999938	62	



Test Item	REQUENCY STABILITY V.S. VOLTAGE
Test Mode	HSUPA 1700 Channel 1413
Test Date	2014-04-08

Reference Frequency: HSUPA Mid Channel 1732.5 MHz @ 20°C				
Limit: ± 2.5 ppm = 4331 Hz				
Power Supply Vac	Environment Temperature (°C)	Frequency (Hz)	Delta (Hz)	Limit (Hz)
253	20	1732500054	54	4331
230		1732500000	0	
207		1732500012	13	

Test Item	REQUENCY STABILITY V.S. VOLTAGE
Test Mode	HSDPA 850 Channel 4183
Test Date	2014-04-08

Reference Frequency: HSDPA Mid Channel 836.6 MHz @ 20°C				
Limit: ± 2.5 ppm = 2090Hz				
Power Supply Vac	Environment Temperature (°C)	Frequency (Hz)	Delta (Hz)	Limit (Hz)
253	20	836599955	45	2090
230		836600000	0	
207		836599910	90	



Test Item	REQUENCY STABILITY V.S. VOLTAGE
Test Mode	HSDPA 1900 Channel 9400
Test Date	2014-04-08

Reference Frequency: HSDPA Mid Channel 1880 MHz @ 20°C				
Limit: ± 2.5 ppm = 4700 Hz				
Power Supply Vac	Environment Temperature (°C)	Frequency (Hz)	Delta (Hz)	Limit (Hz)
253	20	1879999952	48	4700
230		1880000000	0	
207		1879999943	57	

Test Item	REQUENCY STABILITY V.S. VOLTAGE
Test Mode	HSDPA 1700 Channel 1413
Test Date	2014-04-08

Reference Frequency: HSDPA Mid Channel 1732.5 MHz @ 20°C				
Limit: ± 2.5 ppm = 4331Hz				
Power Supply Vac	Environment Temperature (°C)	Frequency (Hz)	Delta (Hz)	Limit (Hz)
253	20	1732500024	24	4331
230		1732500000	0	
207		1732500051	51	