



FCC TEST REPORT

According to

FCC 47 CFR PART 22 SUBPART H AND PART 24 SUBPART E

Applicant	: Guangzhou Robustel Technologies Co., Limited
Address	: No.263 Zhongshan Ave, Tianhe District, Guangzhou, : China 510660
Manufacturer	: Guangzhou Robustel Technologies Co., Limited
Address	: No.263 Zhongshan Ave, Tianhe District, Guangzhou, : China 510660
Equipment	: Industrial Cellular Router
Model No.	: R3000-3P, R3000-3H, R3000-2G, R3000-2E, R3000-4L, : R3000-DUAL
Trade Name	: <i>Robustel</i>
Model Differences	: All models are identical to them except for marketing : purpose, if no specified, model R3000-3P was selected for : test.
FCC ID	: 2AAJGR3K

- The test result refers exclusively to the test presented test model / sample.
- Without written approval of **CerpPASS Technology Corp.** the test report shall not be reproduced except in full.
- The test report must not be used by the clients to claim product certification approval by **NVLAP** or any agency of the Government.



Table of Contents

1. Report of Measurements and Examinations	6
2. Test Configuration of Equipment under Test	7
2.1. Feature of Equipment under Test	7
2.2. Test Manner	8
2.3. Description of Test System	8
2.4. General Information of Test	9
2.5. Measurement Uncertainty	9
3. FIELD STRENGTH OF SPURIOUS RADIATION MEASUREMENT	10
3.1. Test Limit.....	10
3.2. Test Procedures.....	10
3.3. Measurement Equipment	12
3.4. Test Result and Data	13
4. Occupied Bandwidth.....	37
4.1. Test Limit.....	37
4.2. Test Procedures.....	37
4.3. Test Setup Layout.....	37
4.4. Measurement Equipment	37
4.5. Test Result and Data	38
5. Maximum Peak Output Power.....	46
5.1. Test Limit.....	46
5.2. Test Procedure.....	46
5.3. Test Setup Layout.....	46
5.4. Measurement Equipment	46
5.5. Test Result and Data	47
6. ERP & EIRP MEASUREMENT.....	49
6.1. Test Limit.....	49
6.2. Test Procedure.....	49
6.3. Test Setup Layout.....	50
6.4. Measurement Equipment	51
6.5. Test Result and Data	52
7. OUT OF BAND EMISSION AT ANTENNA TERMINALS.....	54
7.1. Test Limit.....	54
7.2. Test Procedure.....	54
7.3. Test Setup Layout.....	54
7.4. Measurement Equipment	54
7.5. Test Result and Data	55
8. FREQUENCY STABILITY V.S. TEMPERATURE MEASUREMENT	67
8.1. Test Limit.....	67
8.2. Test Procedure.....	67
8.3. Test Setup Layout.....	67
8.4. Measurement Equipment	67
8.5. Test Result and Data	68



9. REQUENCY STABILITY V.S. VOLTAGE MEASUREMENT.....	70
9.1. Test Limit.....	70
9.2. Test Procedure.....	70
9.3. Test Setup Layout.....	70
9.4. Measurement Equipment	70
9.5. Test Result and Data	71



Document history

Attachment No.	Date	Description



FCC TEST REPORT

according to

FCC 47 CFR PART 22 SUBPART H AND PART 24 SUBPART E

Applicant	:	Guangzhou Robustel Technologies Co., Limited
Address	:	No.263 Zhongshan Ave, Tianhe District, Guangzhou, China 510660
Manufacturer	:	Guangzhou Robustel Technologies Co., Limited
Address	:	No.263 Zhongshan Ave, Tianhe District, Guangzhou, China 510660
Equipment	:	Industrial Cellular Router
Model No.	:	R3000-3P, R3000-3H, R3000-2G, R3000-2E, R3000-4L, R3000-DUAL
Trade Name	:	Robustel
FCC ID	:	2AAJGR3K

I HEREBY CERTIFY THAT :

The measurements shown in this test report were made in accordance with the procedures given in **ANSI C63.4 – 2009 and TIA/EIA 603** and the energy emitted by this equipment was **passed FCC Rule FCC PART 22 Subpart H and PART 24 Subpart E** in both radiated and conducted emission limits.

Testing was carried out on Jul 10~19,2013 at **CerpPASS Technology Corp.**

Documented By:

Approved By:

Matt Yao / Administration

Miro Chueh / Technical director



1. Report of Measurements and Examinations

FCC 47 CFR PART 22 SUBPART H AND PART 24 SUBPART E ANSI C63.4: 2009 and TIA/EIA 603		
Test Parameter	Test Performed	Remark
Conducted Emission	YES	PASS
Field Strength of Spurious Radiation Measurement	YES	PASS
Occupied Bandwidth	YES	PASS
Maximum Peak Output Power	YES	PASS
ERP & EIRP Measurement	YES	PASS
Out of Band Emission at Antenna Terminals	YES	PASS
Frequency Stability V.S. Temperature Measurement	YES	PASS
Requency Stability V.S. Voltage Measurement	YES	PASS



2. Test Configuration of Equipment under Test

2.1. Feature of Equipment under Test

Industrial Cellular Router	Model No:	R3000-3P
Adapter	Model No.:	SYS1357-1812
	Input:	100-240VAC 50/60Hz 1.0A MAX
	Output:	12.0VDC, 1.5A

Operation Range	Frequency	WCDMA BAND5: 826.4 – 846.6 MHz WCDMA BAND2: 1852.4 – 1907.6 MHz
	Antenna	Dipole antenna1 800~2170MHz 3 dBi Dipole antenna2 824~960MHz 1710~2170MHz 3 dBi Cable Type: RG174 Length: 3M Connector:SMA Male Dimension:34*107mm Weight: 35g



2.2. Test Manner

Test Manner	
a	During testing, the interface cables and equipment positions were varied according to 47 CFR, Part 2, PART 22 Subpart H and PART 24 Subpart E.
b	Adjust the EUT at the test mode and the test channel. Then test.
The test modes:	
<p>The EUT had been tested under operating condition.</p> <p>After verification, all tests were carried out with the worst case test modes as shown below except radiated spurious emission below 1GHz and power line conducted emissions below 30MHz, which worst case was in normal link mode only.</p> <p>EUT staying in continuous transmitting mode was programmed.</p> <p>HSUPA 850: Channel Low (CH4132), Channel Mid (CH4183) and Channel High (CH4233) were chosen for full testing.</p> <p>HSUPA 1900: Channel Low (CH9262), Channel Mid (CH9400) and Channel High (CH9538) were chosen for full testing.</p> <p>HSDPA 850: Channel Low (CH4132), Channel Mid (CH4183) and Channel High (CH4233) were chosen for full testing.</p> <p>HSDPA 1900: Channel Low (CH9262), Channel Mid (CH9400) and Channel High (CH9538) were chosen for full testing.</p>	

2.3. Description of Test System

No.	Device	Manufacturer	Model No.	Description
1	N/A	N/A	N/A	N/A



2.4. General Information of Test

Test Site:	CerpPASS Technology Corp.
Performand Location :	No.66,Tangzhuang Road, Suzhou Industrial Park, Jiangsu 215006, China
NVLAP LAB Code :	200814-0
FCC Registration Number :	916572, 331395
IC Registration Number :	7290A-1, 7290A-2
VCCI Registration Number :	T-1945 for Telecommunication Test C-2919 for Conducted emission test R-2670 for Radiated emission test below 1GHz G-227 for Radiated emission test above 1GHz

Laboratory accreditation



2.5. Measurement Uncertainty

Measurement Item	Measurement Frequency	Polarization	Uncertainty
Conducted Emission	9 kHz ~ 30 MHz	LINE/NEUTRAL	±2.71 dB
Radiated Emission	30 MHz ~ 25GHz	Vertical	±4.11 dB
		Horizontal	±4.10 dB
Occupied Bandwidth	---	---	±7500 Hz
Maximum Peak Output Power	---	---	±1.4 dB
Band Edges	---	---	±2.2 dB
Power Spectral Density	---	---	±2.2 dB



3. FIELD STRENGTH OF SPURIOUS RADIATION MEASUREMENT

3.1. Test Limit

The power of any emission outside of the authorized operating frequency ranges must be attenuated below the transmitting power (P) by a factor of at least $43 + 10\log(P)$ dB.

It is measured by means of a calibrated spectrum analyzer and scanned from 30 MHz up to a frequency including its 10th harmonic.

3.2. Test Procedures

1. The substitution method specified in ANSI/TIA-603-C-2004 is used , and the testing is performed in a FAR, and the EUT is placed on the turn table as shown below.

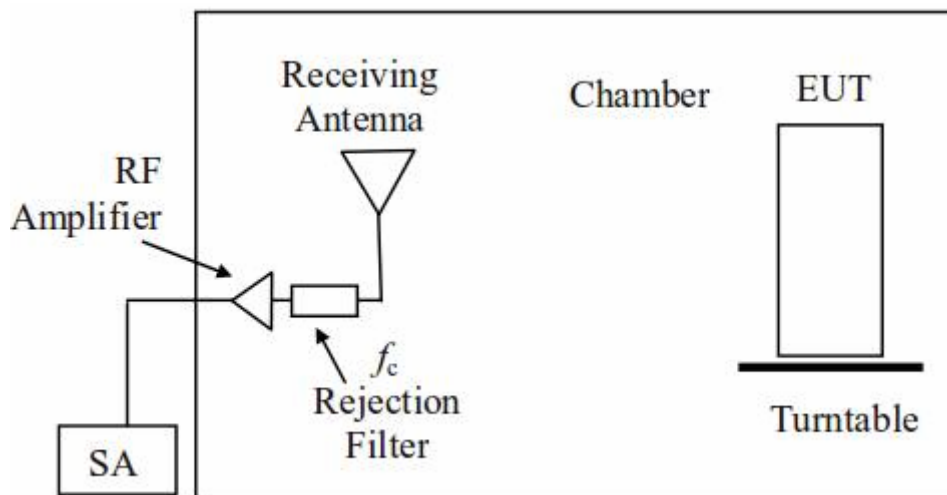

2. Adjust the base station simulator to set the EUT to its maximum power at the required channel.
3. Set the Spectrum Analyzer to measure this channel in in peak hold mode.
4. Rotate the EUT 360 degrees and recorded the peak level in dBm (LVL).
5. Replace the EUT by a half wave dipole or known gain antenna, where the center of the antenna is placed in the same he same location as the center of the antenna of the EUT.

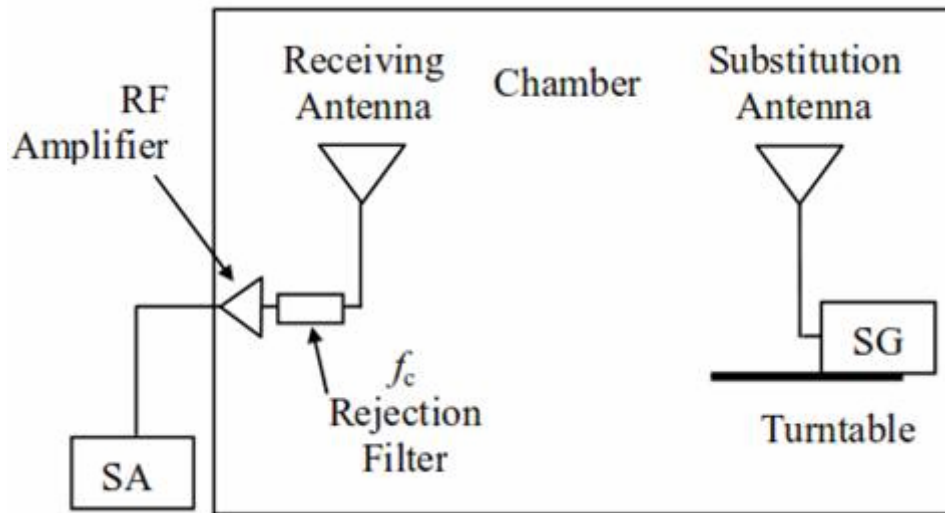

6. Connect the antenna to a signal generator and adjust the output power level of the signal generator (SGP) to the same power as recorded in step 5 on the Spectrum Analyzer.
7. Determine the ERP (dBm)=SGP(dBm)+Gain(dB)- Cable Loss(dB), and add 2.14 dB to calculate the EIRP(dBm)
8. Measure the spurious of the EUT in low, middle and high channel of each frequency band in each modulation mode.



3.3. Measurement Equipment

Instrument	Model No.	Manufacturer	Serial No.	Calibration Date	Valid Date.
Spectrum Analyzer	FSP40	R&S	100324	2013.03.10	2014.03.09
H64 Preamplifier	HP	8447F	3113A05582	2013.03.10	2014.03.09
Preamplifier	Agilent	8449B	3008A02342	2013.03.10	2014.03.09
Ultra Broadband Antenna	R&S	HL562	100362	2013.05.03	2014.05.02
Broad-Band Horn Antenna	Schwarzbeck	BBHA9120D	9120D-619	2013.05.03	2014.05.02
Broad-Band Horn Antenna	Schwarzbeck	BBHA9170	9170-347	2013.05.03	2014.05.02
Spectrum Analyzer	R&S	FSP40	100324	2013.03.10	2014.03.09
Temperature/ Humidity Meter	Zhicheng	ZC1-11	CEP-TH-002	2013.03.10	2014.03.09
Signal Generator	Agilent	E8257D	N/A	2013.08.23	2014.08.23



3.4. Test Result and Data

Radiated Spurious Emission Measurement Result:

Engineer : Matt	Time : 2013-7-10
Site : EMC Lab AC 102	Margin : 6
Limit : FCC_Part22&24	Probe : VERTICAL/ HORIZONTAL
EUT : Industrial Cellular Router	Note : HSUPA 850 / CH 4132

Frequency (MHz)	Antenna Polarization	Antenna Terminals level (dBm)	Substitution Antenna Gain (dBd)	Emission level (dBm)	Limit (dBm)	Margin (dB)
39.26	V	-33.62	-11.29	-44.91	-13.00	-31.91
107.28	V	-32.68	-13.44	-46.12	-13.00	-33.12
110.21	V	-33.28	-13.78	-47.06	-13.00	-34.06
127.81	V	-33.61	-14.15	-47.76	-13.00	-34.76
136.02	V	-34.51	-14.47	-48.98	-13.00	-35.98
828.08	V	-47.06	1.87	-45.19	-13.00	-32.19
74.25	H	-31.26	-16.63	-47.89	-13.00	-34.89
85.91	H	-32.26	-15.27	-47.53	-13.00	-34.53
108.26	H	-32.69	-14.25	-46.94	-13.00	-33.94
127.04	H	-31.25	-14.15	-45.40	-13.00	-32.40
311.02	H	-37.63	-9.74	-47.37	-13.00	-34.37
895.36	H	-44.21	-2.44	-46.65	-13.00	-33.65



Engineer : MATT	Time : 2013-7-10
Site : EMC Lab AC 102	Margin : 6
Limit : FCC_Part22&24	Probe : VERTICAL/ HORIZONTAL
EUT : Industrial Cellular Router	Note : HSUPA 850 / CH 4183

Frequency (MHz)	Antenna Polarization	Antenna Terminals level (dBm)	Substitution Antenna Gain (dBd)	Emission level (dBm)	Limit (dBm)	Margin (dB)
39.26	V	-34.26	-11.29	-45.55	-13.00	-32.55
106.87	V	-33.68	-13.44	-47.12	-13.00	-34.12
111.36	V	-33.20	-13.78	-46.98	-13.00	-33.98
128.04	V	-34.17	-14.15	-48.32	-13.00	-35.32
136.27	V	-33.28	-14.47	-47.75	-13.00	-34.75
827.14	V	-47.19	1.87	-45.32	-13.00	-32.32
75.33	H	-30.36	-16.63	-46.99	-13.00	-33.99
86.29	H	-32.50	-15.27	-47.77	-13.00	-34.77
107.43	H	-31.56	-14.25	-45.81	-13.00	-32.81
127.62	H	-33.62	-14.15	-47.77	-13.00	-34.77
310.85	H	-36.62	-9.74	-46.36	-13.00	-33.36
899.57	H	-43.28	-2.18	-45.46	-13.00	-32.46



Engineer : MATT	Time : 2013-7-10
Site : EMC Lab AC 102	Margin : 6
Limit : FCC_Part22&24	Probe : VERTICAL/ HORIZONTAL
EUT : Industrial Cellular Router	Note : HSUPA 850 / CH 4233

Frequency (MHz)	Antenna Polarization	Antenna Terminals level (dBm)	Substitution Antenna Gain (dBd)	Emission level (dBm)	Limit (dBm)	Margin (dB)
38.26	V	-34.62	-11.29	-45.91	-13.00	-32.91
107.29	V	-33.98	-13.44	-47.42	-13.00	-34.42
117.63	V	-31.59	-13.78	-45.37	-13.00	-32.37
127.93	V	-32.63	-14.15	-46.78	-13.00	-33.78
136.94	V	-33.91	-14.47	-48.38	-13.00	-35.38
830.24	V	-48.52	1.87	-46.65	-13.00	-33.65
75.32	H	-30.52	-16.63	-47.15	-13.00	-34.15
84.63	H	-30.29	-15.27	-45.56	-13.00	-32.56
107.95	H	-31.07	-14.25	-45.32	-13.00	-32.32
128.36	H	-32.06	-14.15	-46.21	-13.00	-33.21
312.26	H	-35.98	-9.74	-45.72	-13.00	-32.72
897.58	H	-45.21	-2.44	-47.65	-13.00	-34.65



Engineer : MATT	Time :2013-7-10
Site : EMC Lab AC 102	Margin : 6
Limit : FCC_Part22&24	Probe : VERTICAL/ HORIZONTAL
EUT : Industrial Cellular Router	Note : HSUPA 1900 / CH 9262

Frequency (MHz)	Antenna Polarization	Antenna Terminals level (dBm)	Substitution Antenna Gain (dBd)	Emission level (dBm)	Limit (dBm)	Margin (dB)
37.28	V	-34.52	-11.01	-45.53	-13.00	-32.53
106.85	V	-31.26	-13.44	-44.70	-13.00	-31.70
109.36	V	-31.26	-13.65	-44.91	-13.00	-31.91
127.24	V	-32.65	-14.15	-46.80	-13.00	-33.80
134.52	V	-32.96	-14.47	-47.43	-13.00	-34.43
827.63	V	-45.36	1.87	-43.49	-13.00	-30.49
74.89	H	-28.89	-16.63	-45.52	-13.00	-32.52
84.63	H	-30.27	-15.27	-45.54	-13.00	-32.54
107.54	H	-33.62	-14.25	-47.87	-13.00	-34.87
128.56	H	-31.89	-14.15	-46.04	-13.00	-33.04
313.06	H	-36.65	-9.74	-46.39	-13.00	-33.39
895.67	H	-42.51	-2.44	-44.95	-13.00	-31.95



Engineer : MATT	Time : 2013-7-10
Site : EMC Lab AC 102	Margin : 6
Limit : FCC_Part22&24	Probe : VERTICAL/ HORIZONTAL
EUT : Industrial Cellular Router	Note : HSUPA 1900 / CH 9400

Frequency (MHz)	Antenna Polarization	Antenna Terminals level (dBm)	Substitution Antenna Gain (dBd)	Emission level (dBm)	Limit (dBm)	Margin (dB)
37.36	V	-34.62	-11.29	-45.91	-13.00	-32.91
101.52	V	-33.91	-11.47	-45.38	-13.00	-32.38
111.51	V	-33.02	-13.78	-46.80	-13.00	-33.80
127.08	V	-32.61	-14.15	-46.76	-13.00	-33.76
136.58	V	-33.48	-14.47	-47.95	-13.00	-34.95
817.62	V	-45.21	1.87	-43.34	-13.00	-30.34
75.36	H	-30.25	-16.63	-46.88	-13.00	-33.88
86.42	H	-31.52	-15.27	-46.79	-13.00	-33.79
107.63	H	-30.63	-14.25	-44.88	-13.00	-31.88
126.96	H	-31.18	-14.15	-45.33	-13.00	-32.33
312.85	H	-33.56	-9.74	-43.30	-13.00	-30.30
896.52	H	-42.61	-2.44	-45.05	-13.00	-32.05



Engineer : MATT	Time : 2013-7-10
Site : EMC Lab AC 102	Margin : 6
Limit : FCC_Part22&24	Probe : VERTICAL/ HORIZONTAL
EUT : Industrial Cellular Router	Note : HSUPA 1900 / CH 9538

Frequency (MHz)	Antenna Polarization	Antenna Terminals level (dBm)	Substitution Antenna Gain (dBd)	Emission level (dBm)	Limit (dBm)	Margin (dB)
38.26	V	-34.52	-11.29	-45.81	-13.00	-32.81
106.42	V	-31.57	-13.44	-45.01	-13.00	-32.01
111.32	V	-32.63	-13.78	-46.41	-13.00	-33.41
127.58	V	-32.63	-14.15	-46.78	-13.00	-33.78
136.57	V	-32.17	-14.47	-46.64	-13.00	-33.64
828.63	V	-48.26	1.87	-46.39	-13.00	-33.39
75.63	H	-30.26	-16.63	-46.89	-13.00	-33.89
86.39	H	-30.62	-15.27	-45.89	-13.00	-32.89
107.51	H	-30.57	-14.25	-44.82	-13.00	-31.82
128.57	H	-32.51	-14.15	-46.66	-13.00	-33.66
311.36	H	-36.59	-9.74	-46.33	-13.00	-33.33
897.18	H	-43.55	-2.44	-45.99	-13.00	-32.99



Engineer : Matt	Time : 2013-7-10
Site : EMC Lab AC 102	Margin : 6
Limit : FCC_Part22&24	Probe : VERTICAL/ HORIZONTAL
EUT : Industrial Cellular Router	Note : HSDPA 850 / CH 4132

Frequency (MHz)	Antenna Polarization	Antenna Terminals level (dBm)	Substitution Antenna Gain (dBd)	Emission level (dBm)	Limit (dBm)	Margin (dB)
36.69	V	-33.52	-11.29	-44.81	-13.00	-31.81
107.84	V	-32.17	-13.44	-45.61	-13.00	-32.61
112.26	V	-34.14	-13.78	-47.92	-13.00	-34.92
128.01	V	-33.25	-14.15	-47.40	-13.00	-34.40
137.15	V	-34.85	-14.47	-49.32	-13.00	-36.32
828.64	V	-46.25	1.87	-44.38	-13.00	-31.38
74.52	H	-31.24	-16.63	-47.87	-13.00	-34.87
85.69	H	-32.55	-15.27	-47.82	-13.00	-34.82
108.67	H	-33.25	-14.25	-47.50	-13.00	-34.50
127.82	H	-32.14	-14.15	-46.29	-13.00	-33.29
312.05	H	-37.14	-9.74	-46.88	-13.00	-33.88
895.67	H	-43.25	-2.44	-45.69	-13.00	-32.69



Engineer : MATT	Time : 2013-7-10
Site : EMC Lab AC 102	Margin : 6
Limit : FCC_Part22&24	Probe : VERTICAL/ HORIZONTAL
EUT : Industrial Cellular Router	Note : HSDPA 850 / CH 4183

Frequency (MHz)	Antenna Polarization	Antenna Terminals level (dBm)	Substitution Antenna Gain (dBd)	Emission level (dBm)	Limit (dBm)	Margin (dB)
39.68	V	-34.51	-11.29	-45.80	-13.00	-32.80
107.84	V	-33.96	-13.44	-47.40	-13.00	-34.40
111.69	V	-33.14	-13.78	-46.92	-13.00	-33.92
128.96	V	-34.51	-14.15	-48.66	-13.00	-35.66
137.41	V	-32.58	-14.47	-47.05	-13.00	-34.05
827.95	V	-46.25	1.87	-44.38	-13.00	-31.38
75.66	H	-31.24	-16.63	-47.87	-13.00	-34.87
87.01	H	-32.63	-15.27	-47.90	-13.00	-34.90
107.84	H	-32.02	-14.25	-46.27	-13.00	-33.27
127.96	H	-33.58	-14.15	-47.73	-13.00	-34.73
311.04	H	-37.48	-9.74	-47.22	-13.00	-34.22
900.02	H	-42.51	-2.18	-44.69	-13.00	-31.69



Engineer : MATT	Time : 2013-7-10
Site : EMC Lab AC 102	Margin : 6
Limit : FCC_Part22&24	Probe : VERTICAL/ HORIZONTAL
EUT : Industrial Cellular Router	Note : HSDPA 850 / CH 4233

Frequency (MHz)	Antenna Polarization	Antenna Terminals level (dBm)	Substitution Antenna Gain (dBd)	Emission level (dBm)	Limit (dBm)	Margin (dB)
38.51	V	-35.02	-11.29	-46.31	-13.00	-33.31
107.14	V	-34.25	-13.44	-47.69	-13.00	-34.69
118.01	V	-32.56	-13.78	-46.34	-13.00	-33.34
128.24	V	-33.07	-14.15	-47.22	-13.00	-34.22
137.51	V	-34.15	-14.47	-48.62	-13.00	-35.62
831.25	V	-47.52	1.87	-45.65	-13.00	-32.65
75.36	H	-30.51	-16.63	-47.14	-13.00	-34.14
84.59	H	-30.66	-15.27	-45.93	-13.00	-32.93
108.52	H	-31.87	-14.25	-46.12	-13.00	-33.12
127.89	H	-32.57	-14.15	-46.72	-13.00	-33.72
313.20	H	-36.85	-9.74	-46.59	-13.00	-33.59
898.11	H	-44.15	-2.44	-46.59	-13.00	-33.59



Engineer : MATT	Time :2013-7-10
Site : EMC Lab AC 102	Margin : 6
Limit : FCC_Part22&24	Probe : VERTICAL/ HORIZONTAL
EUT : Industrial Cellular Router	Note : HSDPA 1900 / CH 9262

Frequency (MHz)	Antenna Polarization	Antenna Terminals level (dBm)	Substitution Antenna Gain (dBd)	Emission level (dBm)	Limit (dBm)	Margin (dB)
37.52	V	-34.51	-11.29	-45.80	-13.00	-32.80
107.41	V	-32.05	-13.44	-45.49	-13.00	-32.49
110.25	V	-31.59	-13.78	-45.37	-13.00	-32.37
128.24	V	-33.69	-14.15	-47.84	-13.00	-34.84
134.63	V	-32.78	-14.47	-47.25	-13.00	-34.25
827.96	V	-44.15	1.87	-42.28	-13.00	-29.28
75.01	H	-29.96	-16.63	-46.59	-13.00	-33.59
86.63	H	-30.65	-15.27	-45.92	-13.00	-32.92
107.84	H	-34.05	-14.25	-48.30	-13.00	-35.30
128.63	H	-32.81	-14.15	-46.96	-13.00	-33.96
313.07	H	-37.48	-9.74	-47.22	-13.00	-34.22
896.62	H	-41.08	-2.44	-43.52	-13.00	-30.52



Engineer : MATT	Time : 2013-7-10
Site : EMC Lab AC 102	Margin : 6
Limit : FCC_Part22&24	Probe : VERTICAL/ HORIZONTAL
EUT : Industrial Cellular Router	Note : HSDPA 1900 / CH 9400

Frequency (MHz)	Antenna Polarization	Antenna Terminals level (dBm)	Substitution Antenna Gain (dBd)	Emission level (dBm)	Limit (dBm)	Margin (dB)
37.51	V	-33.63	-11.29	-44.92	-13.00	-31.92
101.59	V	-34.15	-11.47	-45.62	-13.00	-32.62
111.57	V	-33.26	-13.78	-47.04	-13.00	-34.04
127.59	V	-32.87	-14.15	-47.02	-13.00	-34.02
137.51	V	-33.84	-14.47	-48.31	-13.00	-35.31
818.63	V	-44.57	1.87	-42.70	-13.00	-29.70
75.96	H	-30.62	-16.63	-47.25	-13.00	-34.25
87.51	H	-31.52	-15.27	-46.79	-13.00	-33.79
107.89	H	-30.57	-14.25	-44.82	-13.00	-31.82
127.62	H	-32.59	-14.15	-46.74	-13.00	-33.74
312.33	H	-34.51	-9.74	-44.25	-13.00	-31.25
897.00	H	-41.52	-2.44	-43.96	-13.00	-30.96



Engineer : MATT	Time : 2013-7-10
Site : EMC Lab AC 102	Margin : 6
Limit : FCC_Part22&24	Probe : VERTICAL/ HORIZONTAL
EUT : Industrial Cellular Router	Note : HSDPA 1900 / CH 9538

Frequency (MHz)	Antenna Polarization	Antenna Terminals level (dBm)	Substitution Antenna Gain (dBd)	Emission level (dBm)	Limit (dBm)	Margin (dB)
38.62	V	-34.52	-11.29	-45.81	-13.00	-32.81
106.52	V	-32.14	-11.47	-43.61	-13.00	-30.61
112.21	V	-33.62	-13.78	-47.40	-13.00	-34.40
127.96	V	-32.57	-14.15	-46.72	-13.00	-33.72
136.89	V	-33.25	-14.47	-47.72	-13.00	-34.72
829.67	V	-47.14	1.87	-45.27	-13.00	-32.27
75.96	H	-31.24	-16.63	-47.87	-13.00	-34.87
86.94	H	-31.52	-15.27	-46.79	-13.00	-33.79
107.84	H	-31.09	-14.25	-45.34	-13.00	-32.34
129.69	H	-32.56	-14.15	-46.71	-13.00	-33.71
312.51	H	-36.51	-9.74	-46.25	-13.00	-33.25
897.48	H	-42.15	-2.44	-44.59	-13.00	-31.59



Engineer : MATT	Time : 2013-7-10
Site : EMC Lab AC 102	Margin : 6
Limit : FCC_Part22&24	Probe : VERTICAL/ HORIZONTAL
EUT : Industrial Cellular Router	Note : HSUPA 850 / CH 4132

Frequency (MHz)	Antenna Polarization	Antenna Terminals level (dBm)	Substitution Antenna Gain (dBi)	Emission level (dBm)	Limit (dBm)	Margin (dB)
3189.26	V	-48.51	1.29	-47.22	-13.00	-34.22
3201.41	H	-49.17	1.31	-47.86	-13.00	-34.86



Engineer : MATT	Time : 2013-7-10
Site : EMC Lab AC 102	Margin : 6
Limit : FCC_Part22&24	Probe : VERTICAL/ HORIZONTAL
EUT : Industrial Cellular Router	Note : HSUPA 850 / CH 4183

Frequency (MHz)	Antenna Polarization	Antenna Terminals level (dBm)	Substitution Antenna Gain (dBi)	Emission level (dBm)	Limit (dBm)	Margin (dB)
3189.52	V	-48.62	1.29	-47.33	-13.00	-34.33
3201.47	H	-49.99	1.31	-48.68	-13.00	-35.68



Engineer : MATT	Time : 2013-7-10
Site : EMC Lab AC 102	Margin : 6
Limit : FCC_Part22&24	Probe : VERTICAL/ HORIZONTAL
EUT : Industrial Cellular Router	Note : HSUPA 850 / CH 4233

Frequency (MHz)	Antenna Polarization	Antenna Terminals level (dBm)	Substitution Antenna Gain (dBi)	Emission level (dBm)	Limit (dBm)	Margin (dB)
3189.52	V	-48.62	1.29	-47.33	-13.00	-34.33
3201.47	H	-49.99	1.31	-48.68	-13.00	-35.68



Engineer : MATT	Time : 2013-7-10
Site : EMC Lab AC 102	Margin : 6
Limit : FCC_Part22&24	Probe : VERTICAL/ HORIZONTAL
EUT : Industrial Cellular Router	Note : HSUPA 1900 / CH 9262

Frequency (MHz)	Antenna Polarization	Antenna Terminals level (dBm)	Substitution Antenna Gain (dBi)	Emission level (dBm)	Limit (dBm)	Margin (dB)
3200.59	V	-48.62	1.29	-47.33	-13.00	-34.33
3201.47	H	-49.96	1.31	-48.65	-13.00	-35.65



Engineer : MATT	Time : 2013-7-10
Site : EMC Lab AC 102	Margin : 6
Limit : FCC_Part22&24	Probe : VERTICAL/ HORIZONTAL
EUT : Industrial Cellular Router	Note : HSUPA 1900 / CH 9400

Frequency (MHz)	Antenna Polarization	Antenna Terminals level (dBm)	Substitution Antenna Gain (dBi)	Emission level (dBm)	Limit (dBm)	Margin (dB)
3196.25	V	-49.06	1.29	-47.77	-13.00	-34.77
3201.56	H	-50.42	1.31	-49.11	-13.00	-36.11



Engineer : MATT	Time : 2013-7-10
Site : EMC Lab AC 102	Margin : 6
Limit : FCC_Part22&24	Probe : VERTICAL/ HORIZONTAL
EUT : Industrial Cellular Router	Note : HSUPA 1900 / CH 9538

Frequency (MHz)	Antenna Polarization	Antenna Terminals level (dBm)	Substitution Antenna Gain (dBi)	Emission level (dBm)	Limit (dBm)	Margin (dB)
3189.63	V	-48.96	1.29	-47.67	-13.00	-34.67
3203.51	H	-51.42	1.31	-50.11	-13.00	-37.11



Engineer : MATT	Time : 2013-7-10
Site : EMC Lab AC 102	Margin : 6
Limit : FCC_Part22&24	Probe : VERTICAL/ HORIZONTAL
EUT : Industrial Cellular Router	Note : HSDPA 850 / CH 4132

Frequency (MHz)	Antenna Polarization	Antenna Terminals level (dBm)	Substitution Antenna Gain (dBi)	Emission level (dBm)	Limit (dBm)	Margin (dB)
3189.99	V	-47.59	1.29	-46.30	-13.00	-33.30
3201.59	H	-49.02	1.31	-47.71	-13.00	-34.71



Engineer : MATT	Time : 2013-7-10
Site : EMC Lab AC 102	Margin : 6
Limit : FCC_Part22&24	Probe : VERTICAL/ HORIZONTAL
EUT : Industrial Cellular Router	Note : HSDPA 850 / CH 4183

Frequency (MHz)	Antenna Polarization	Antenna Terminals level (dBm)	Substitution Antenna Gain (dBi)	Emission level (dBm)	Limit (dBm)	Margin (dB)
3190.25	V	-47.69	1.29	-46.40	-13.00	-33.40
3201.47	H	-48.55	1.31	-47.24	-13.00	-34.24



Engineer : MATT	Time : 2013-7-10
Site : EMC Lab AC 102	Margin : 6
Limit : FCC_Part22&24	Probe : VERTICAL/ HORIZONTAL
EUT : Industrial Cellular Router	Note : HSDPA 850 / CH 4233

Frequency (MHz)	Antenna Polarization	Antenna Terminals level (dBm)	Substitution Antenna Gain (dBi)	Emission level (dBm)	Limit (dBm)	Margin (dB)
3200.14	V	-47.15	1.29	-45.86	-13.00	-32.86
3201.58	H	-49.62	1.31	-48.31	-13.00	-35.31



Engineer : MATT	Time : 2013-7-10
Site : EMC Lab AC 102	Margin : 6
Limit : FCC_Part22&24	Probe : VERTICAL/ HORIZONTAL
EUT : Industrial Cellular Router	Note : HSDPA 1900 / CH 9262

Frequency (MHz)	Antenna Polarization	Antenna Terminals level (dBm)	Substitution Antenna Gain (dBi)	Emission level (dBm)	Limit (dBm)	Margin (dB)
3197.48	V	-47.96	1.29	-46.67	-13.00	-33.67
3202.59	H	-48.59	1.31	-47.28	-13.00	-34.28



Engineer : MATT	Time : 2013-7-10
Site : EMC Lab AC 102	Margin : 6
Limit : FCC_Part22&24	Probe : VERTICAL/ HORIZONTAL
EUT : Industrial Cellular Router	Note : HSDPA 1900 / CH 9400

Frequency (MHz)	Antenna Polarization	Antenna Terminals level (dBm)	Substitution Antenna Gain (dBi)	Emission level (dBm)	Limit (dBm)	Margin (dB)
3197.85	V	-48.51	1.29	-47.22	-13.00	-34.22
3202.66	H	-49.89	1.31	-48.58	-13.00	-35.58



Engineer : MATT	Time : 2013-7-10
Site : EMC Lab AC 102	Margin : 6
Limit : FCC_Part22&24	Probe : VERTICAL/ HORIZONTAL
EUT : Industrial Cellular Router	Note : HSDPA 1900 / CH 9538

Frequency (MHz)	Antenna Polarization	Antenna Terminals level (dBm)	Substitution Antenna Gain (dBi)	Emission level (dBm)	Limit (dBm)	Margin (dB)
3198.96	V	-48.99	1.29	-47.70	-13.00	-34.70
3202.51	H	-49.98	1.31	-48.67	-13.00	-35.67



4. Occupied Bandwidth

4.1. Test Limit

According to §FCC 2.1049.

4.2. Test Procedures

The EUT's output RF connector was connected with a short cable to the spectrum analyzer, RBW was set to about 1% of emission BW, VBW is set to 3 times the RBW, -26dBc display line was placed on the screen (or 99% bandwidth), the occupied bandwidth is the delta frequency between the two points where the display line intersects the signal trace.

4.3. Test Setup Layout

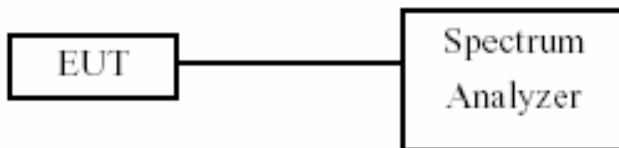

4.4. Measurement Equipment

Instrument/Ancillary	Model No.	Manufacturer	Serial No.	Calibration Date	Valid Date
Spectrum Analyzer	FSP40	R&S	100324	2013.03.10	2014.03.09
Temperature/ Humidity Meter	Zhicheng	ZC1-11	CEP-TH-002	2013.03.10	2014.03.09



4.5. Test Result and Data

Test Item	Occupied Bandwidth
Test Mode	HSUPA 850
Test Date	2013-07-17

Channel No.	Frequency (MHz)	Measurement Level (kHz)
4132	826.4	4560.00
4183	836.6	4600.00
4233	846.6	4580.00

Channel 4132

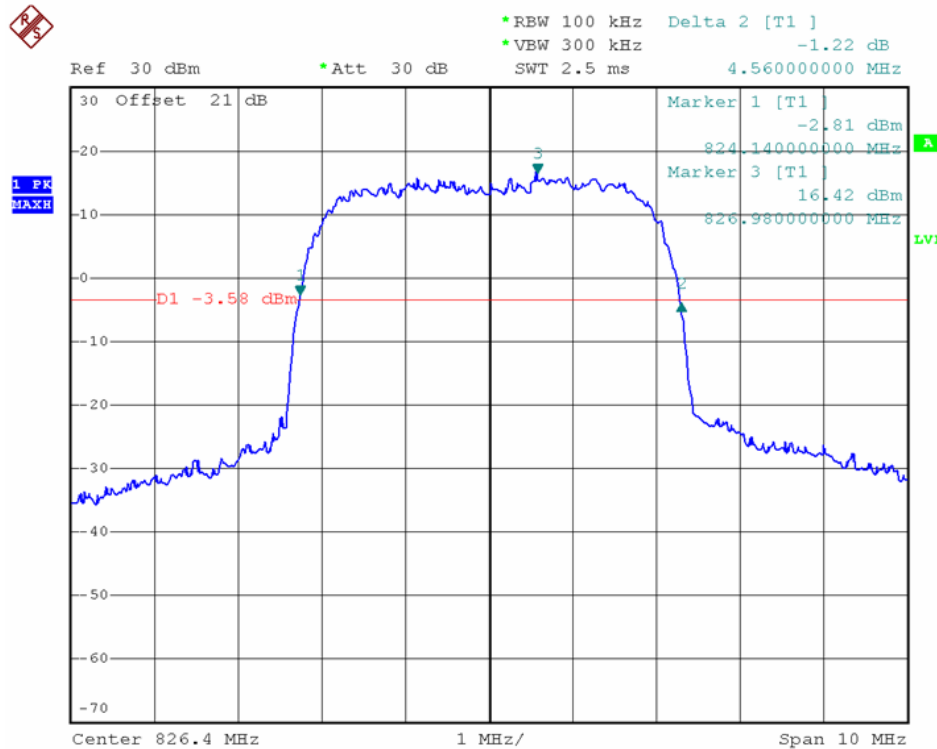



Channel 4183

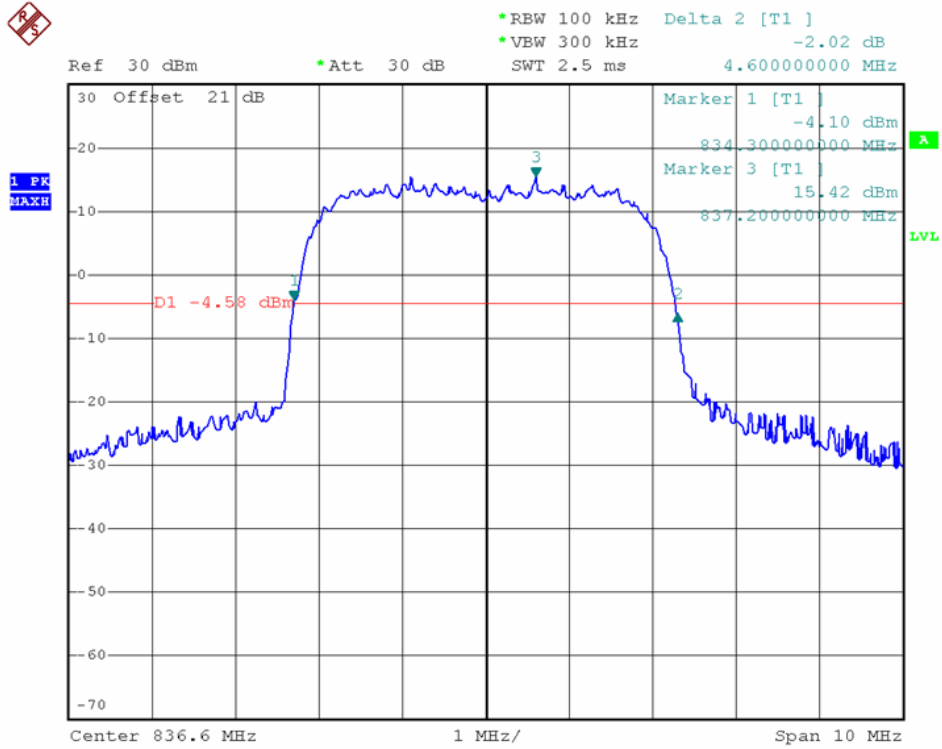

Channel 4233

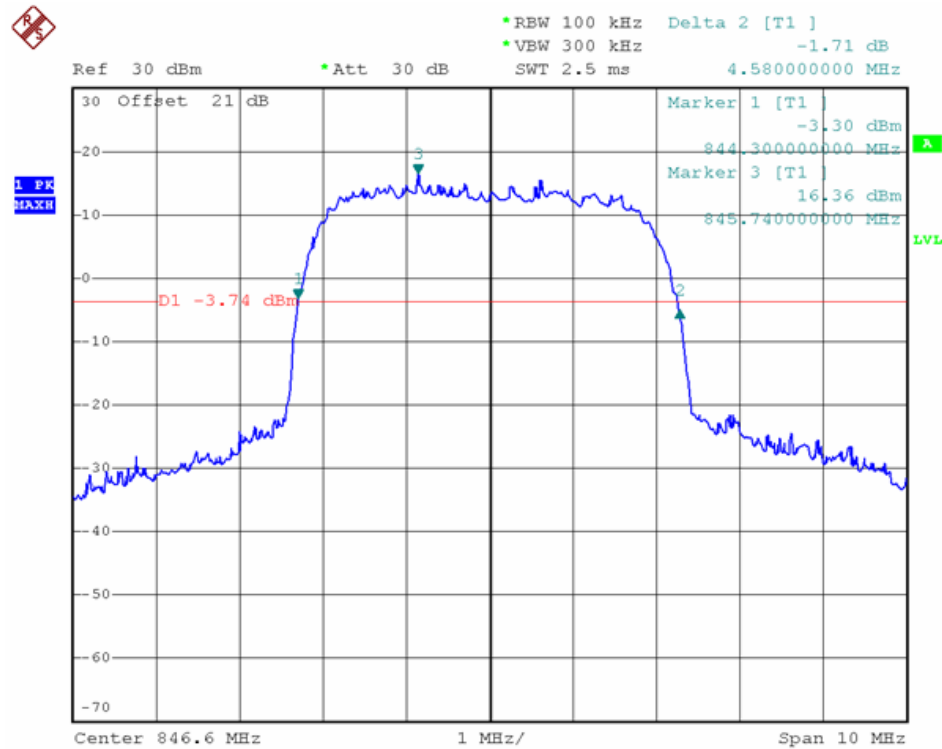



Test Item	Occupied Bandwidth
Test Mode	HSUPA 1900
Test Date	2013-07-17

Channel No.	Frequency (MHz)	Measurement Level (kHz)
9262	1852.4	4520.00
9400	1880.0	4500.00
9538	1907.6	4480.00

Channel 9262

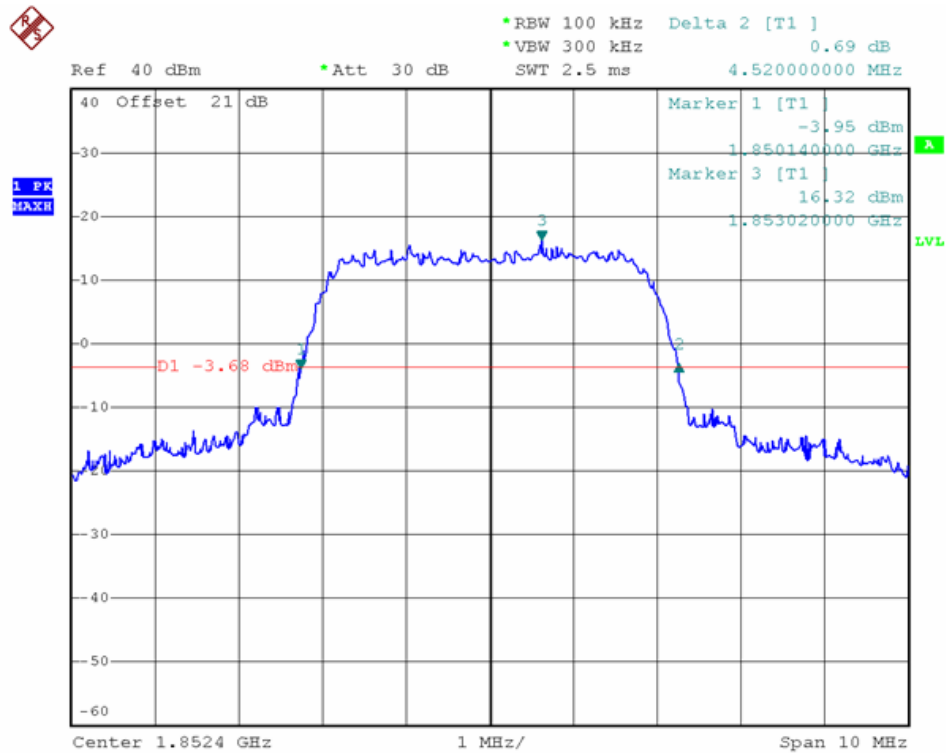



Channel 9400

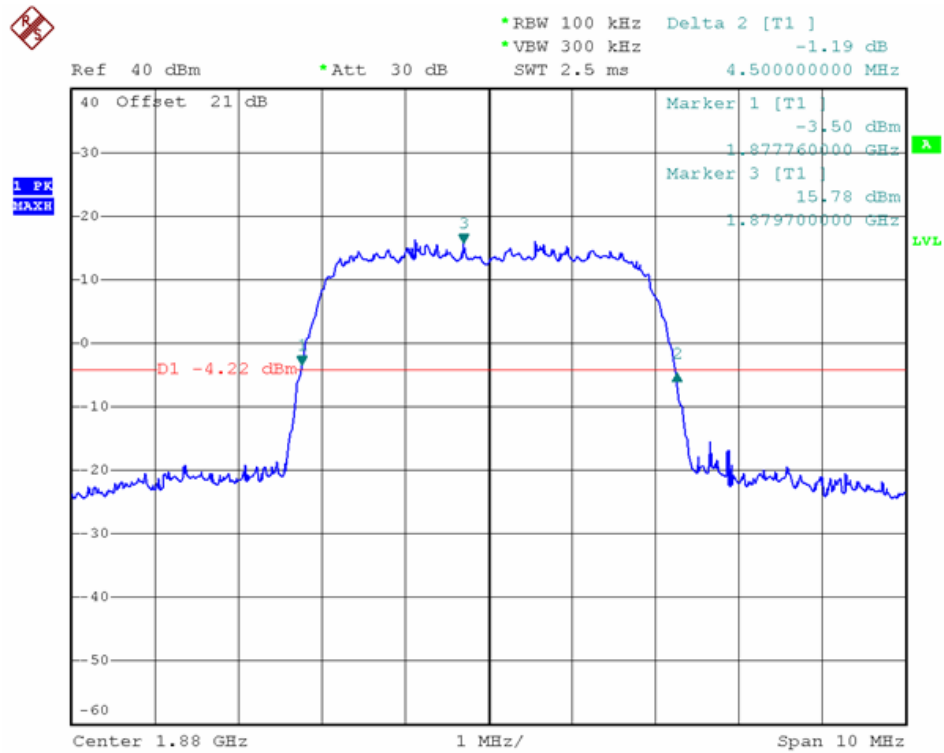

Channel 9538

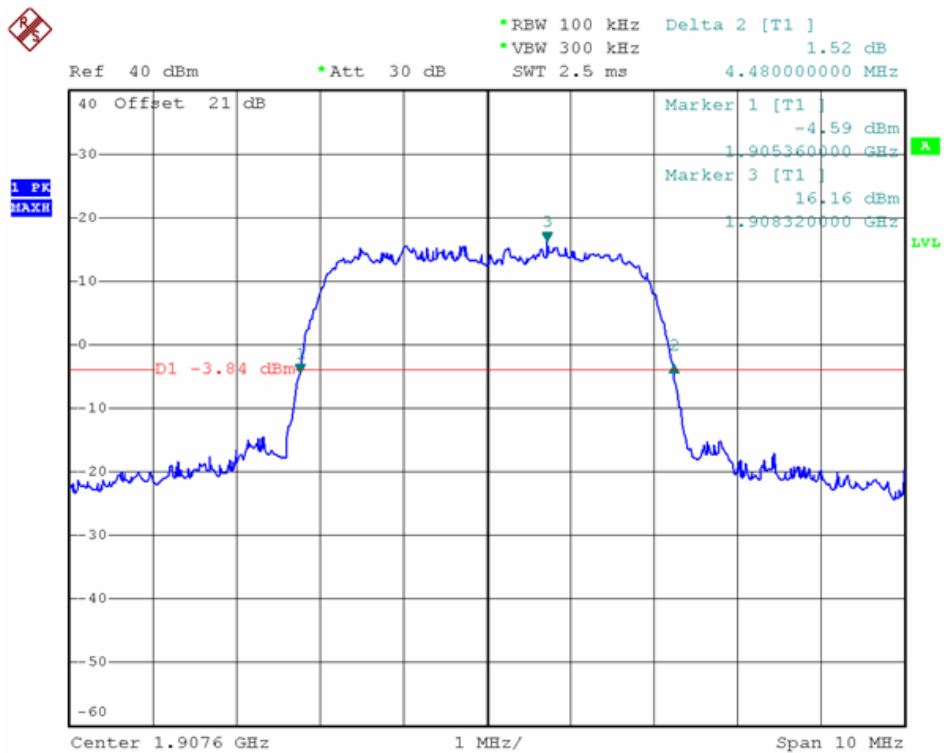



Test Item	Occupied Bandwidth
Test Mode	HSDPA 850
Test Date	2013-07-17

Channel No.	Frequency (MHz)	Measurement Level (kHz)
4132	826.4	4540.00
4183	836.6	4600.00
4233	846.6	4600.00

Channel 4132

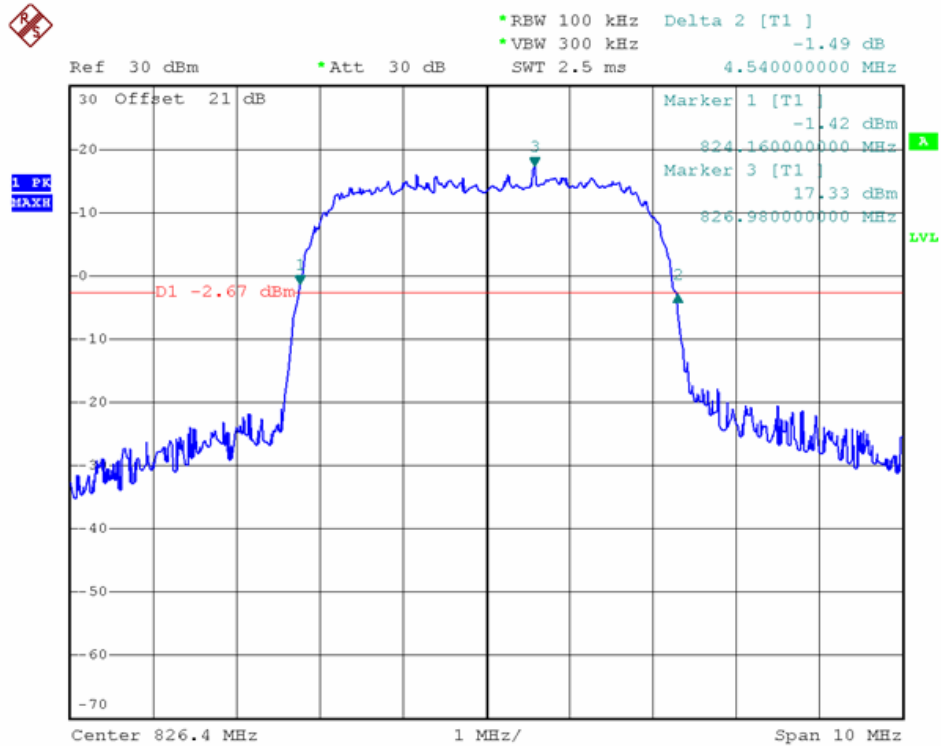



Channel 4183

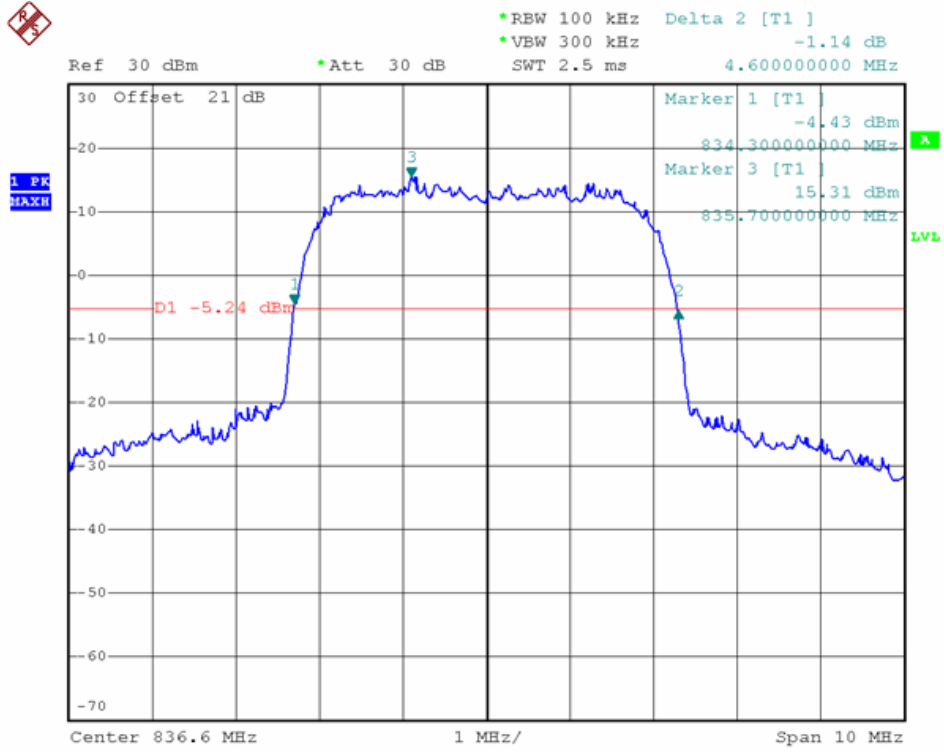

Channel 4233

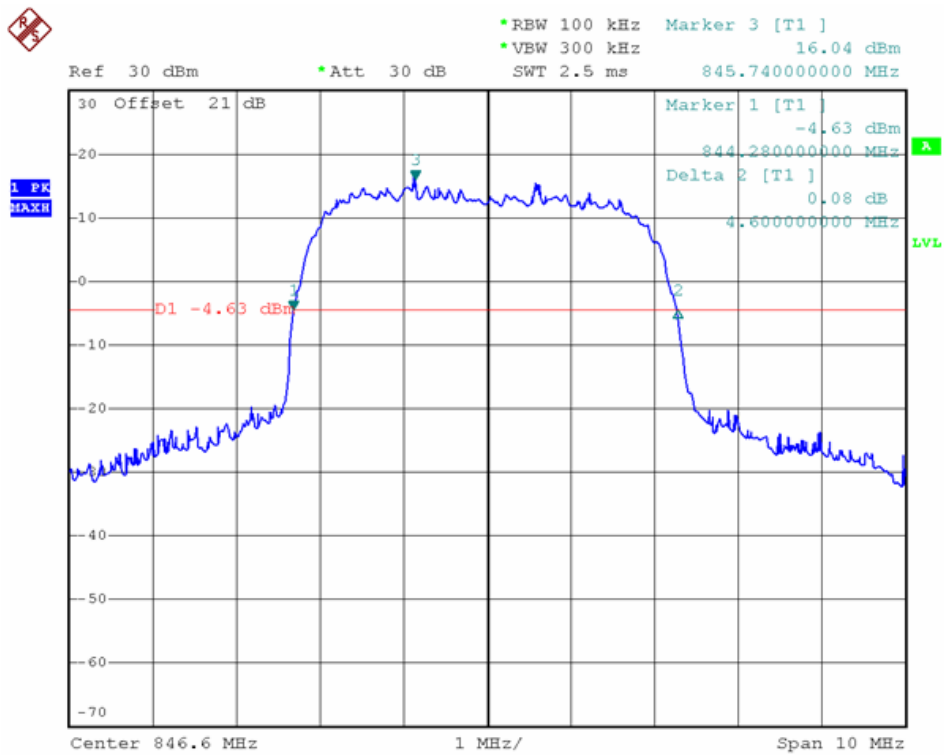



Test Item	Occupied Bandwidth
Test Mode	HSDPA 1900
Test Date	2013-07-17

Channel No.	Frequency (MHz)	Measurement Level (kHz)
9262	1852.4	4180.00
9400	1880.0	6500.00
9538	1907.6	6400.00

Channel 9262

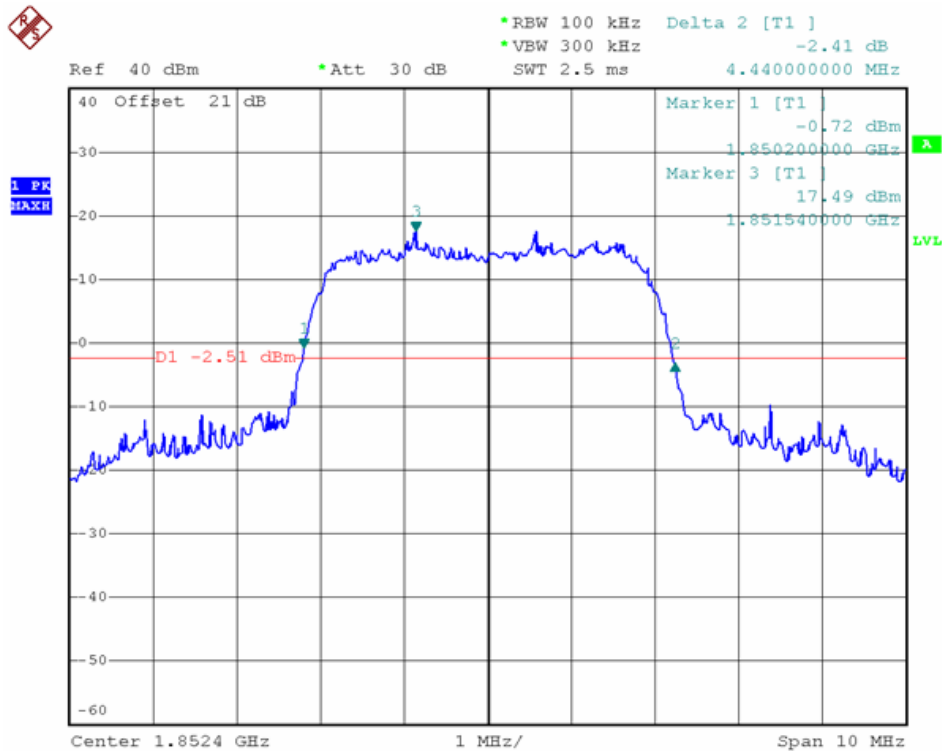



Channel 9400

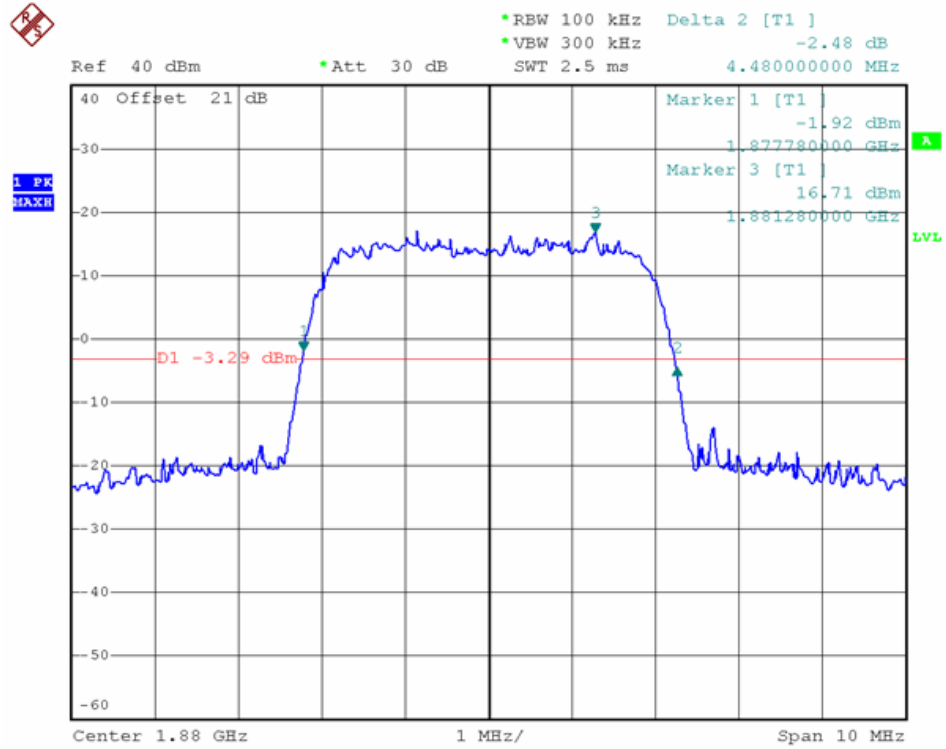

Channel 9538

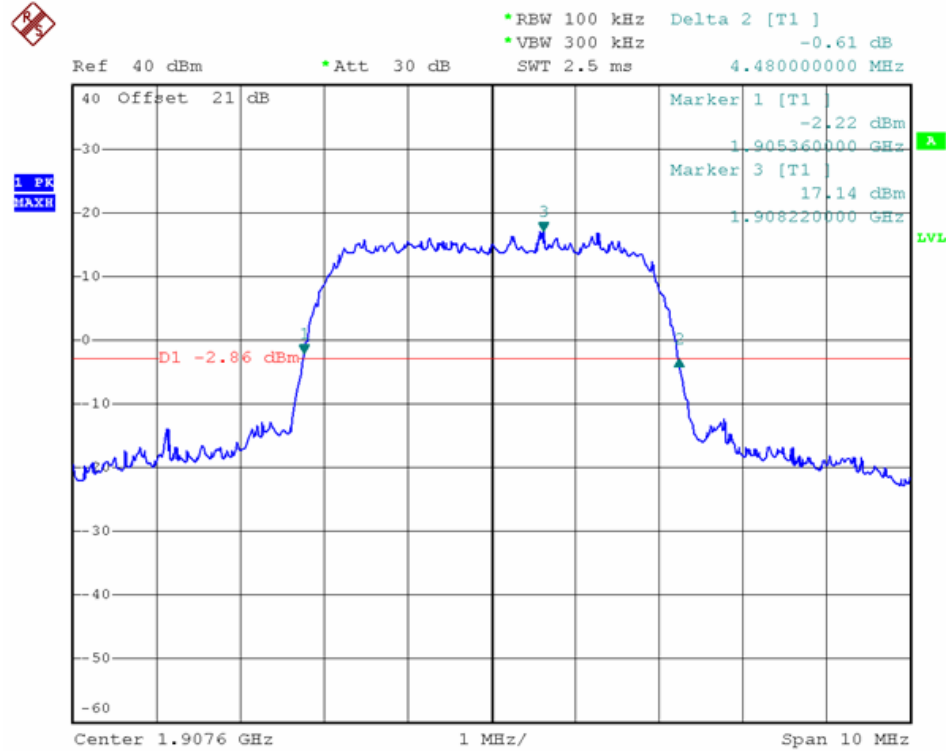



5. Maximum Peak Output Power

5.1. Test Limit

According to FCC §2.1046.

5.2. Test Procedure

The transmitter output was connected to a calibrated attenuator, the other end of which was connected to a power meter. Transmitter output was read off the power meter in dBm. The power output at the transmitter antenna port was determined by adding the value of the attenuator to the power meter reading.

5.3. Test Setup Layout

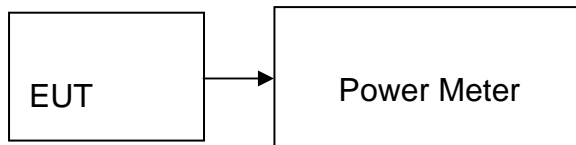

5.4. Measurement Equipment

Instrument/Ancillary	Model No.	Manufacturer	Serial No.	Calibration Date	Valid Date
Power Meter	NRP	R&S	101206	2013.03.10	2014.03.09
Power Sensor	NRP-Z91	R&S	100385	2013.03.10	2014.03.09
Temperature/ Humidity Meter	Zhicheng	ZC1-11	CEP-TH-002	2013.03.10	2014.03.09



5.5. Test Result and Data

Test Item	Maximum Peak Output Power
Test Mode	HSUPA 850
Test Date	2013-07-17

Channel No.	Frequency (MHz)	Peak Power (dBm)
4132	826.4	21.41
4183	836.6	21.46
4233	846.6	21.09

Test Item	Maximum Peak Output Power
Test Mode	HSUPA 1900
Test Date	2013-07-17

Channel No.	Frequency (MHz)	Peak Power (dBm)
9262	1852.4	22.33
9400	1880.0	21.59
9538	1907.6	21.05



Test Item	Maximum Peak Output Power
Test Mode	HSDPA 850
Test Date	2013-07-17

Channel No.	Frequency (MHz)	Peak Power (dBm)
4132	826.4	21.56
4183	836.6	21.89
4233	846.6	21.01

Test Item	Maximum Peak Output Power
Test Mode	HSDPA 1900
Test Date	2013-07-17

Channel No.	Frequency (MHz)	Peak Power (dBm)
9262	1852.4	22.38
9400	1880.0	21.63
9538	1907.6	20.71



6. ERP & EIRP MEASUREMENT

6.1. Test Limit

According to FCC §2.1046

FCC 22.913(a): The Effective Radiated Power (ERP) of mobile transmitters must not exceed 7 Watts.

FCC 24.232(b): The equivalent Isotropic Radiated Power (EIRP) must not exceed 2 Watts.

6.2. Test Procedure

The EUT was placed on a non-conductive turntable using a non-conductive support. The radiated emission at the fundamental frequency was measured at 3 m with a test antenna and EMI spectrum analyzer.

During the measurement of the EUT, the resolution bandwidth was set to 3MHz and the average bandwidth was set to 3MHz. The highest emission was recorded with the rotation of the turntable and the lowering of the test antenna. The reading was recorded and the field strength (E in dBuV/m) was calculated.

ERP in frequency band 824-849MHz, and EIRP in frequency band 1850 –1910MHz were measured using a substitution method. The EUT was replaced by half-wave dipole (824-849MHz) or horn antenna (1850-1910MHz) connected to a signal generator. The spectrum analyzer reading was recorded and ERP/EIRP was calculated as follows:

$$\text{ERP} = \text{S.G. output (dBm)} + \text{Antenna Gain (dBd)} - \text{Cable (dB)}$$

$$\text{EIRP} = \text{S.G. output (dBm)} + \text{Antenna Gain (dBi)} - \text{Cable (dB)}$$



6.3. Test Setup Layout

Below 1 GHz

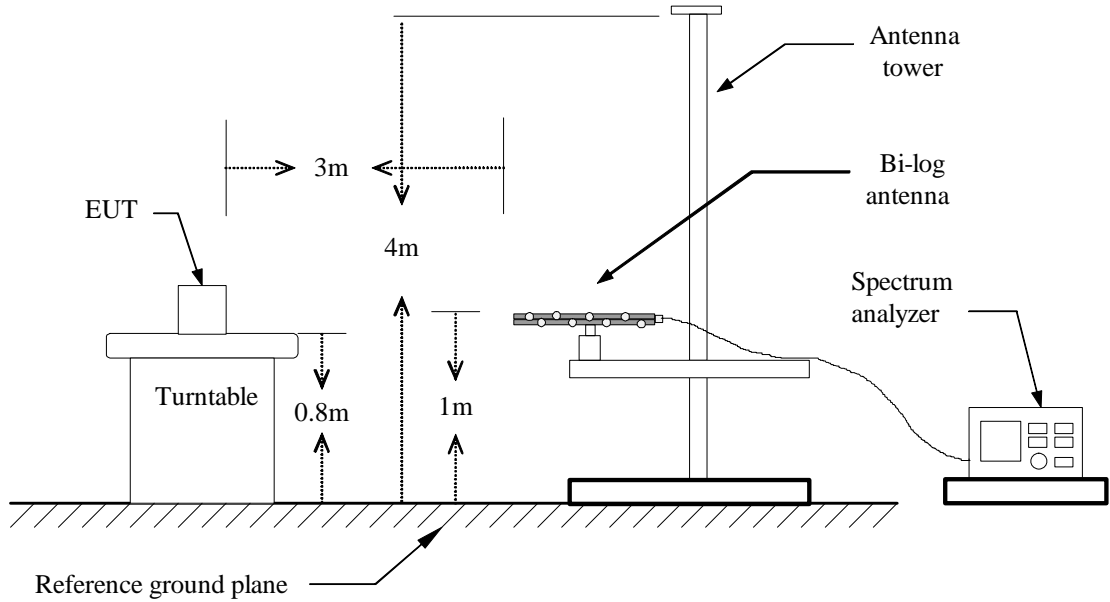

Above 1 GHz

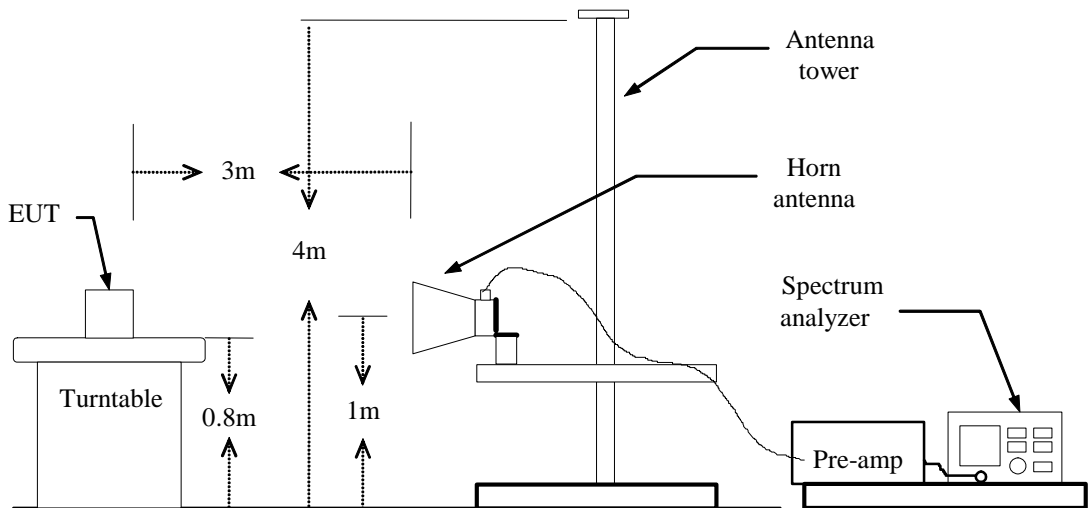



For Substituted Method Test Set-UP

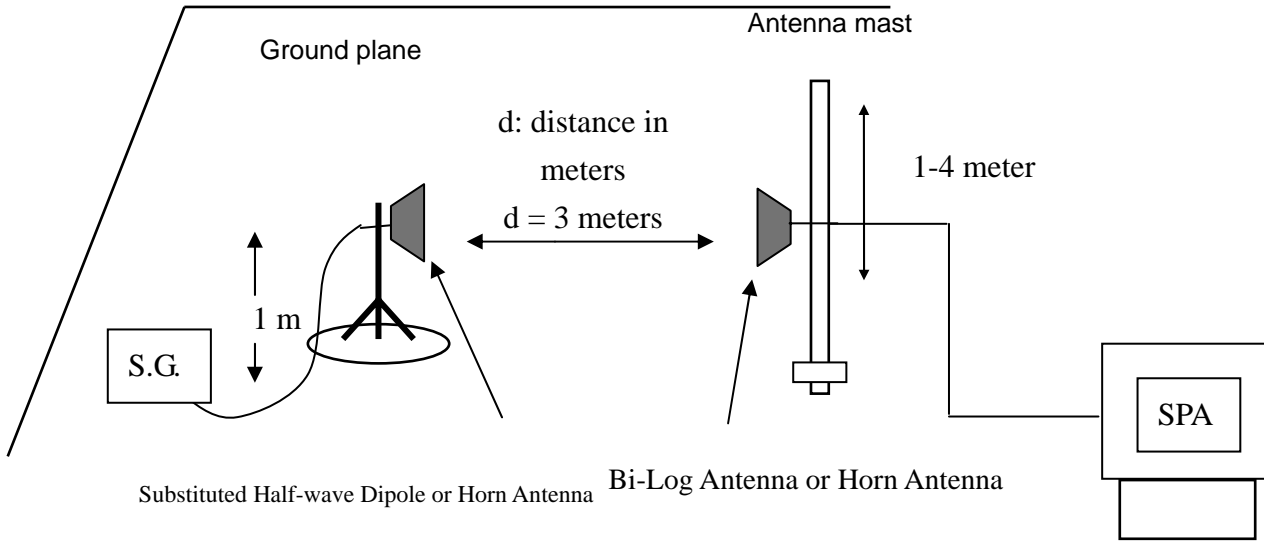

6.4. Measurement Equipment

Instrument/Ancillary	Model No.	Manufacturer	Serial No.	Calibration Date	Valid Date
Spectrum Analyzer	R&S	FSP40	100324	2013.03.10	2014.03.09
H64 Amplifier	HP	8447F	3113A05582	2013.03.10	2014.03.09
Preamplifier	Agilent	8449B	ED-HE-EMI-077	2013.03.10	2014.03.09
Broad-Band Horn Antenna	Schwarzbeck	BBHA9120D	9120D-619	2013.05.03	2014.05.02
Temperature/ Humidity Meter	Zhicheng	ZC1-11	CEP-TH-002	2013.03.10	2014.03.09



6.5. Test Result and Data

HSUPA 850 TEST DATA

Channel	Frequency (MHz)	Antenna Pol.	Reading level (Peak) (dB)	Correction Factor (dB)	Emission level (dBm)	Limit (dBm)	Margin (dB)
4132	826.4	V	28.67	1.01	29.68	38.5	-8.82
	826.4	H	31.33	0.96	32.29	38.5	-6.21
4183	836.6	V	30.21	1.77	31.98	38.5	-6.52
	836.6	H	32.17	1.46	33.63	38.5	-4.87
4233	846.6	V	31.09	1.85	32.94	38.5	-5.56
	846.6	H	30.17	1.54	31.71	38.5	-6.79

HSUPA 1900 TEST DATA

Channel	Frequency (MHz)	Antenna Pol.	Reading level (Peak) (dB)	Correction Factor (dB)	Emission level (dBm)	Limit (dBm)	Margin (dB)
9262	1852.4	V	26.12	2.34	28.46	33	-4.54
	1852.4	H	24.29	1.88	26.17	33	-6.83
9400	1880.0	V	25.18	2.12	27.30	33	-5.70
	1880.0	H	24.44	2.41	26.85	33	-6.15
9538	1907.6	V	25.10	2.34	27.44	33	-5.56
	1907.6	H	25.83	1.98	27.81	33	-5.19



HSDPA 850 TEST DATA

Channel	Frequency (MHz)	Antenna Pol.	Reading level (Peak) (dB)	Correction Factor (dB)	Emission level (dBm)	Limit (dBm)	Margin (dB)
4132	826.4	V	29.17	1.01	30.18	38.5	-8.32
	826.4	H	30.17	0.96	31.13	38.5	-7.37
4183	836.6	V	30.67	1.77	32.44	38.5	-6.06
	836.6	H	30.09	1.46	31.55	38.5	-6.95
4233	846.6	V	30.45	1.85	32.30	38.5	-6.20
	846.6	H	29.87	1.54	31.41	38.5	-7.09

HADPA 1900 TEST DATA

Channel	Frequency (MHz)	Antenna Pol.	Reading level (Peak) (dB)	Correction Factor (dB)	Emission level (dBm)	Limit (dBm)	Margin (dB)
9262	1852.4	V	25.42	2.34	27.76	33	-5.24
	1852.4	H	24.10	1.88	25.98	33	-7.02
9400	1880.0	V	24.56	2.12	26.68	33	-6.32
	1880.0	H	25.64	2.41	28.05	33	-4.95
9538	1907.6	V	25.19	2.34	27.53	33	-5.47
	1907.6	H	24.10	1.98	26.08	33	-6.92



7. OUT OF BAND EMISSION AT ANTENNA TERMINALS

7.1. Test Limit

According to FCC §2.1051, FCC §22.917, FCC §24.238(a).

Out of Band Emissions: The mean power of emission must be attenuated below the mean power of the non-modulated carrier (P) on any frequency twice or more than twice the fundamental frequency by at least $43 + 10 \log P$ dB.

Mobile Emissions in Base Frequency Range: The mean power of any emissions appearing in the base station frequency range from cellular mobile transmitters operated must be attenuated to a level not exceed -80 dBm at the transmit antenna connector.

Band Edge Requirements: In the 1MHz bands immediately outside and adjacent to the frequency block, a resolution bandwidth of at least 1% of the emission bandwidth of the fundamental emission of the transmitter may be employed to measure the Out of band Emission.

7.2. Test Procedure

The RF output of the transceiver was connected to a spectrum analyzer through appropriate attenuation. The resolution bandwidth of the spectrum analyzer was set at 1MHz, sufficient scans were taken to show the out of band Emissions if any up to 10th harmonic.

For the out of band: Set the RBW, VBW = 1MHz, Start=30MHz, Stop= 10 th harmonic. Limit = -13dBm

Band Edge Requirements (824 MHz and 849 MHz /1850MHz and 1910MHz): In the 1 MHz bands immediately outside and adjacent to the frequency block, a resolution bandwidth of at least 1 percent of the emission bandwidth of the fundamental emission of the transmitter may be employed to measure the out of band Emissions. Limit, -13dBm.

7.3. Test Setup Layout

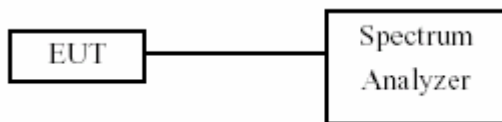

7.4. Measurement Equipment

Instrument/Ancillary	Model No.	Manufacturer	Serial No.	Calibration Date	Valid Date
Spectrum Analyzer	FSP40	R&S	100324	2013.03.10	2014.03.09
Temperature/ Humidity Meter	Zhicheng	ZC1-11	CEP-TH-002	2013.03.10	2014.03.09



7.5. Test Result and Data

Test Item	Conducted spurious emissions, 30MHz - 20GHz
Test Mode	HSUPA 850
Test Date	2013-07-17

Channel 4132

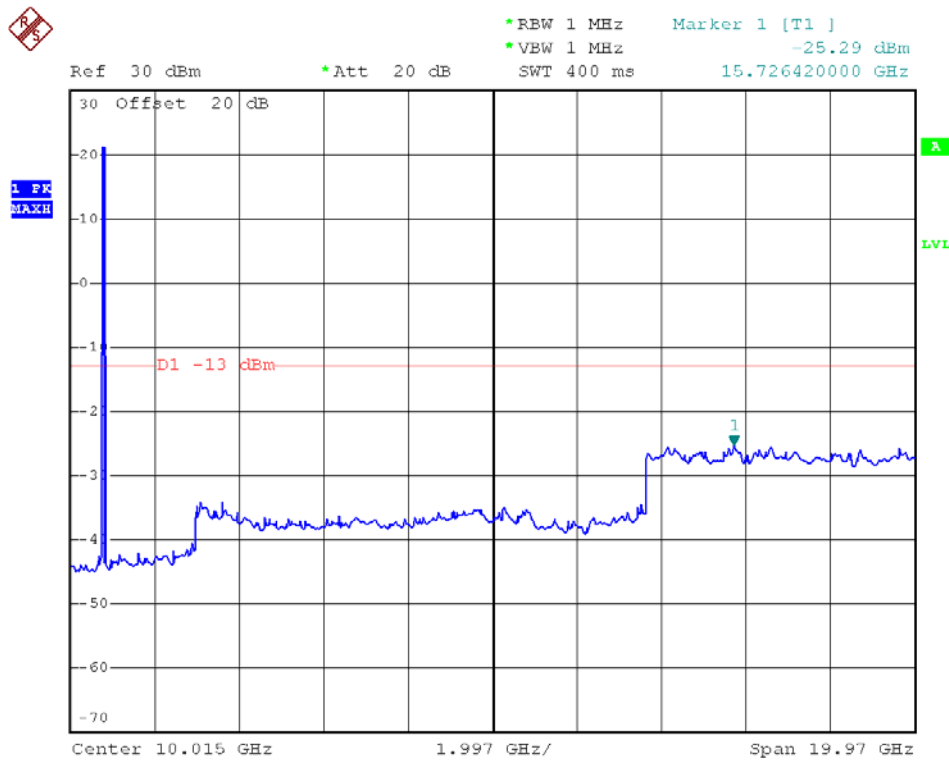



Channel 4183

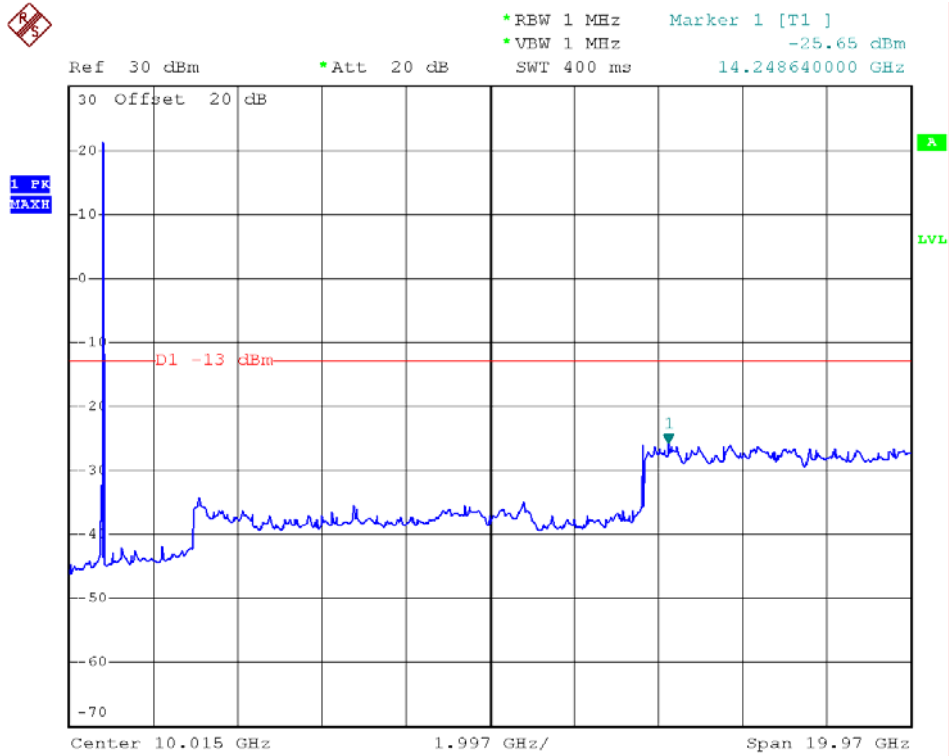

Channel 4233

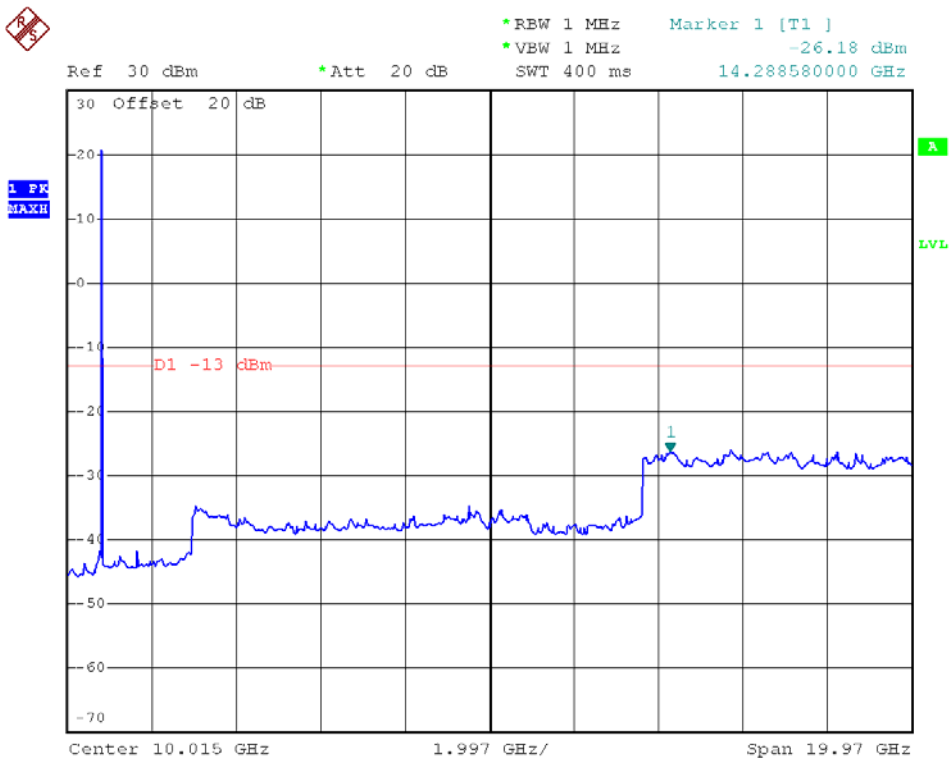



Test Item	Conducted spurious emissions, 30MHz - 20GHz
Test Mode	HSUPA 1900
Test Date	2013-07-17

Channel 9262

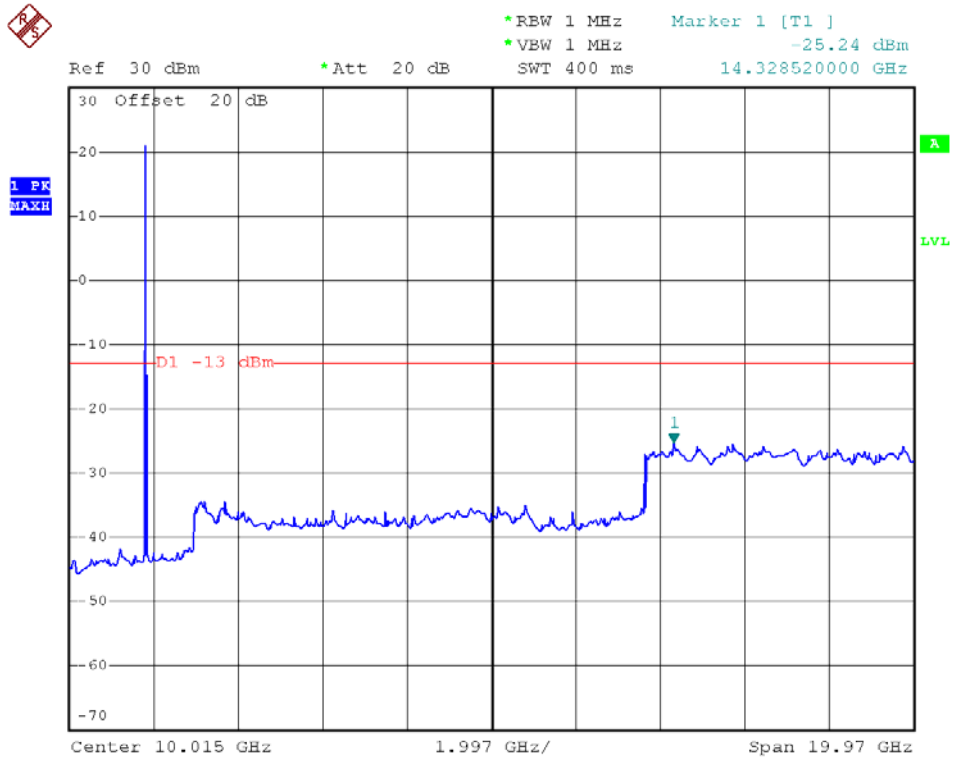



Channel 9400

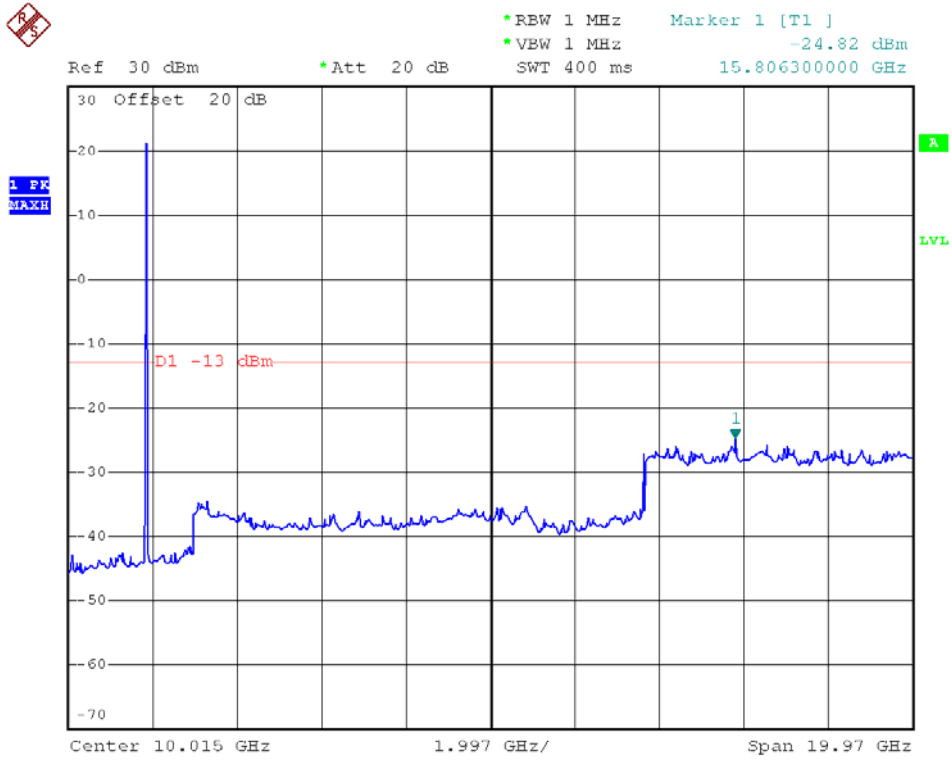

Channel 9538

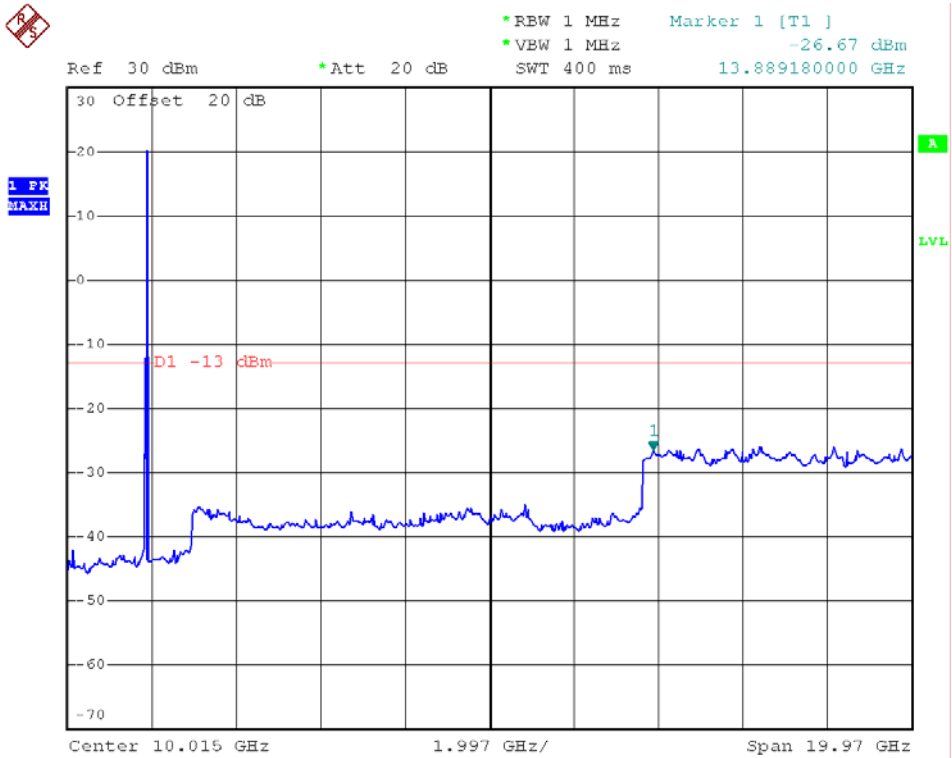



Test Item	Conducted spurious emissions, 30MHz - 20GHz
Test Mode	HSDPA 850
Test Date	2013-07-17

Channel 4132

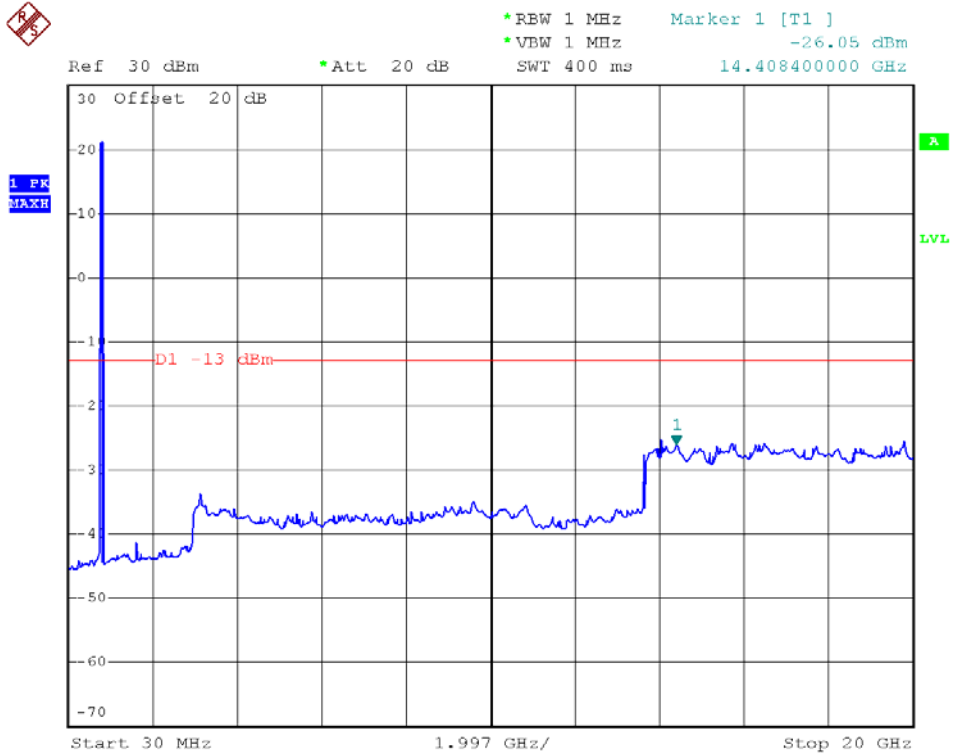



Channel 4183

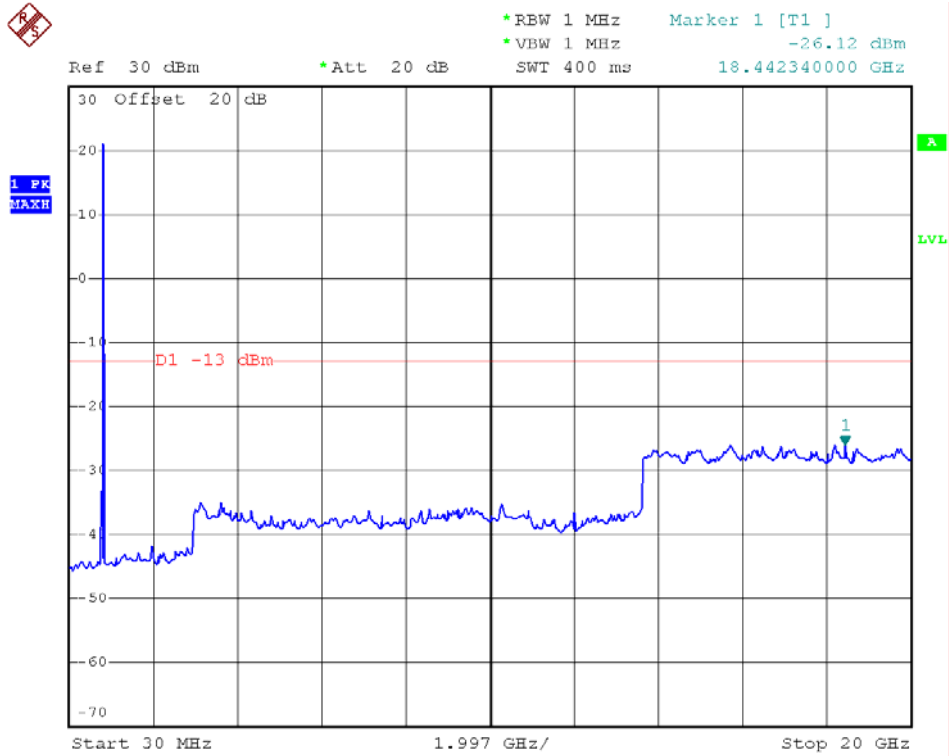

Channel 4233

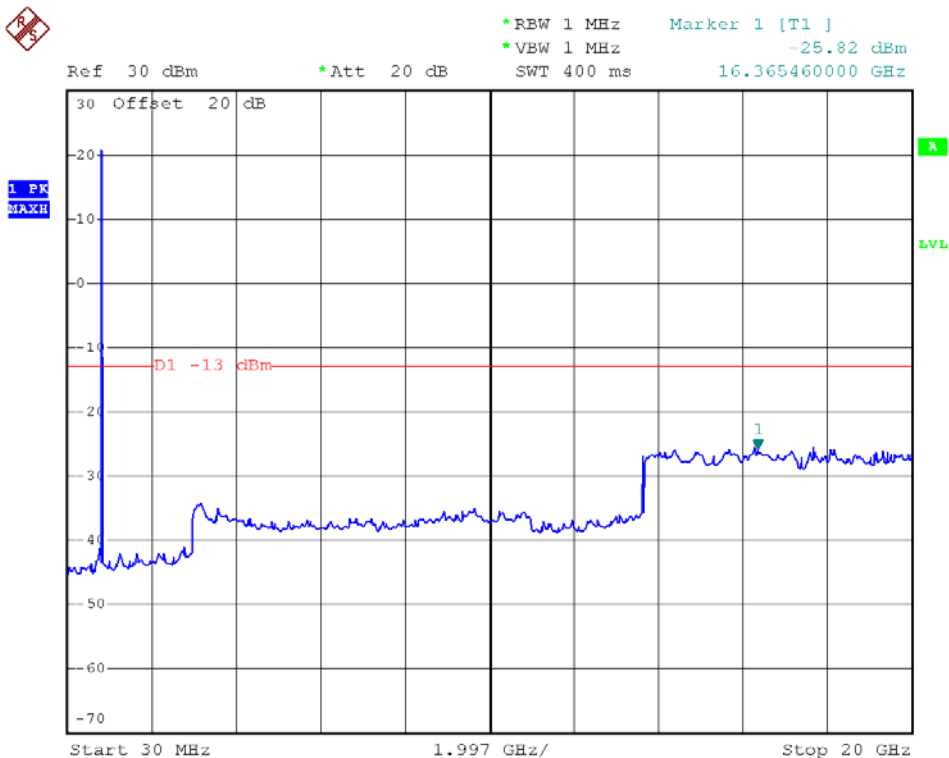



Test Item	Conducted spurious emissions, 30MHz - 20GHz
Test Mode	HSDPA 1900
Test Date	2013-07-17

Channel 9262

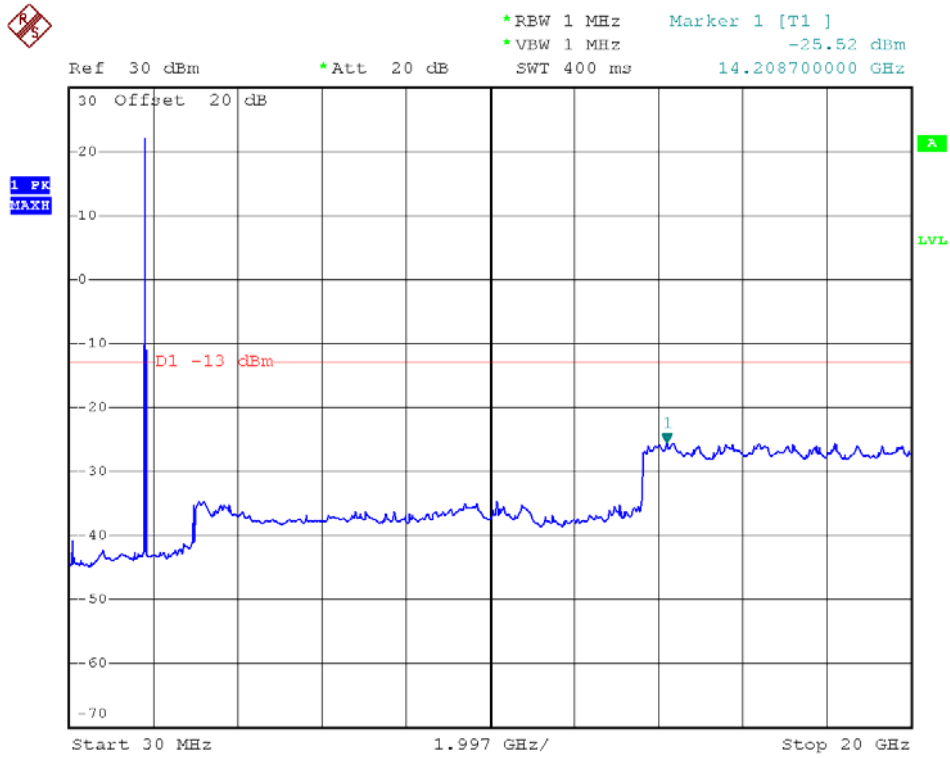



Channel 9400

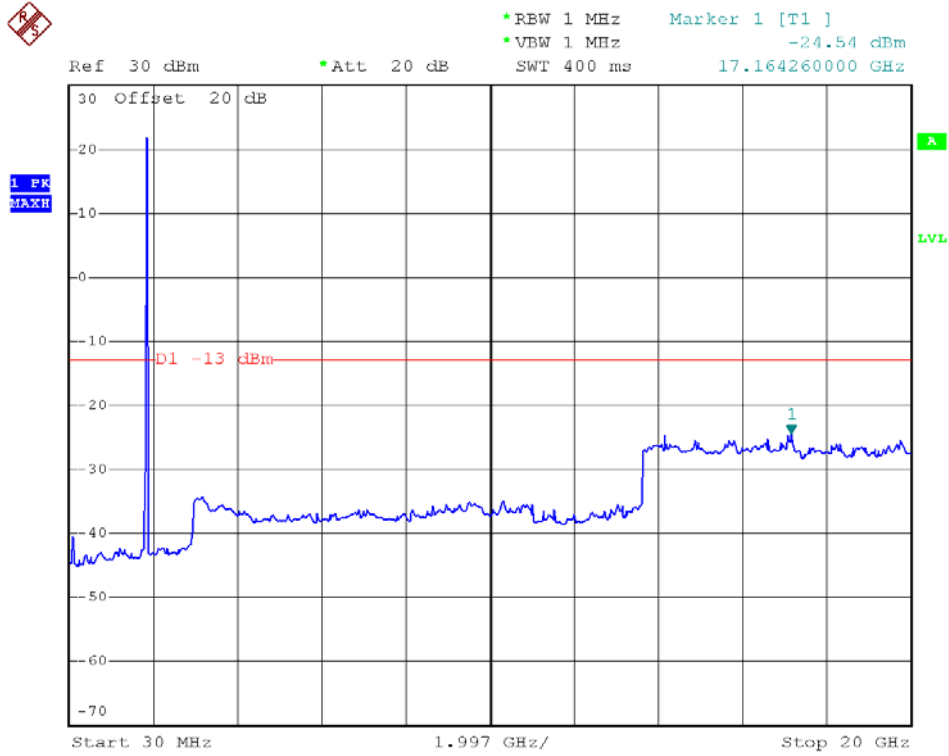

Channel 9538

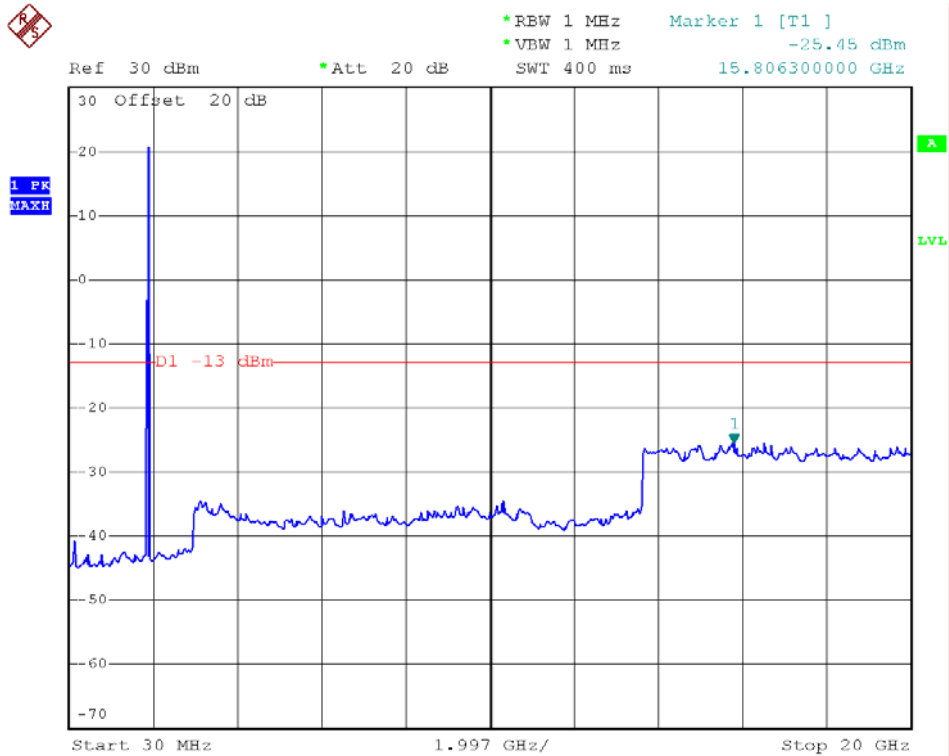



Test Item	Band Edge emissions
Test Mode	HSUPA 850
Test Date	2013-07-17

Channel 4132

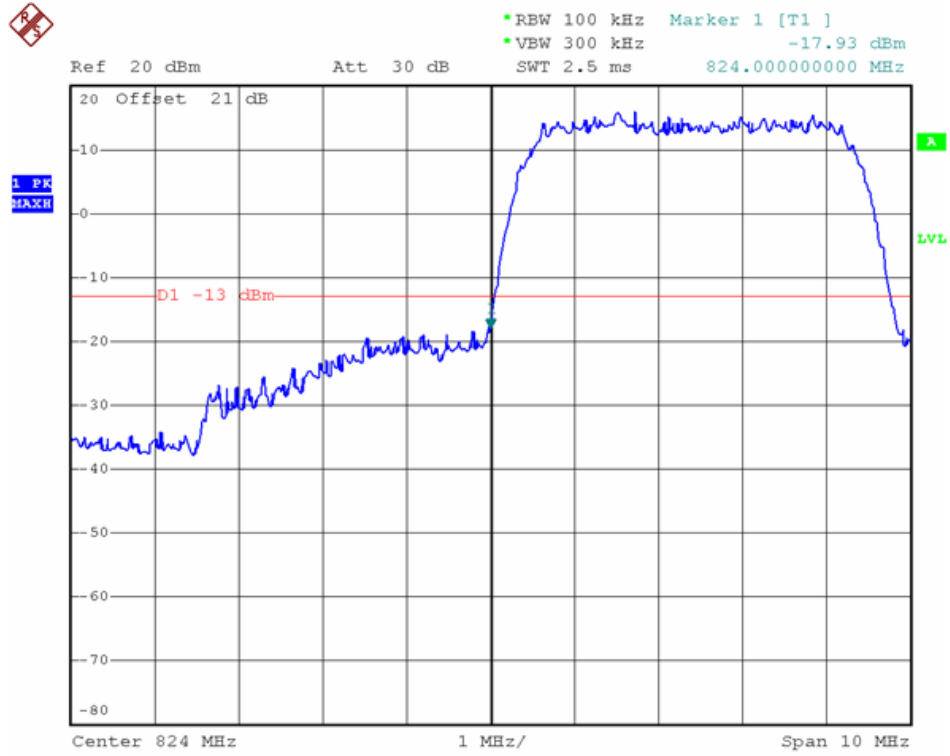

Channel 4233

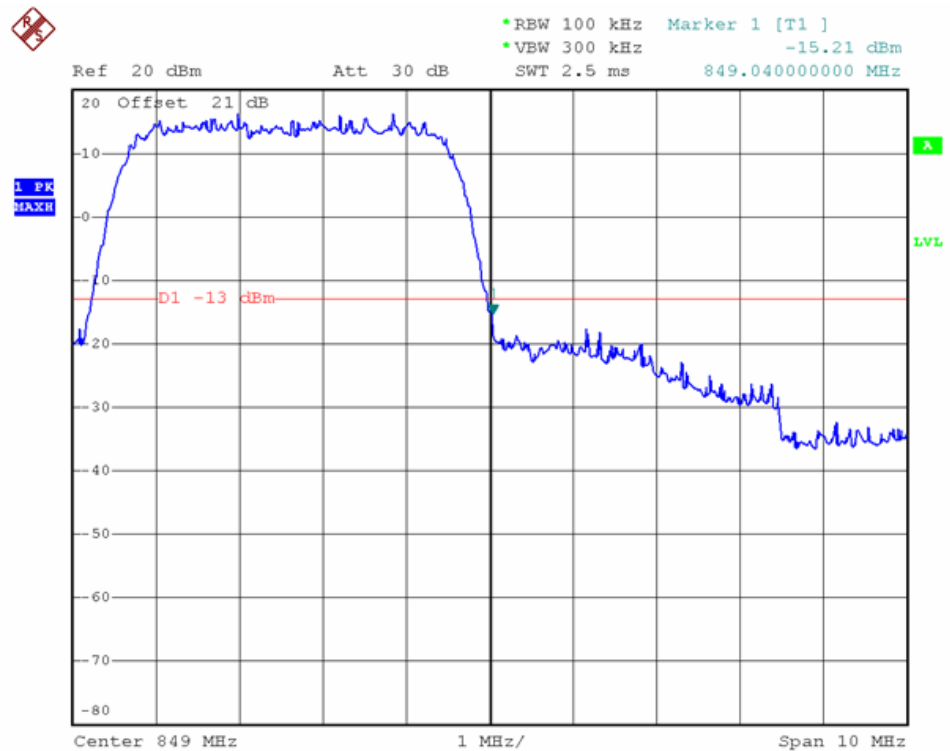



Test Item	Band Edge emissions
Test Mode	HSUPA 1900
Test Date	2013-07-17

Channel 9262

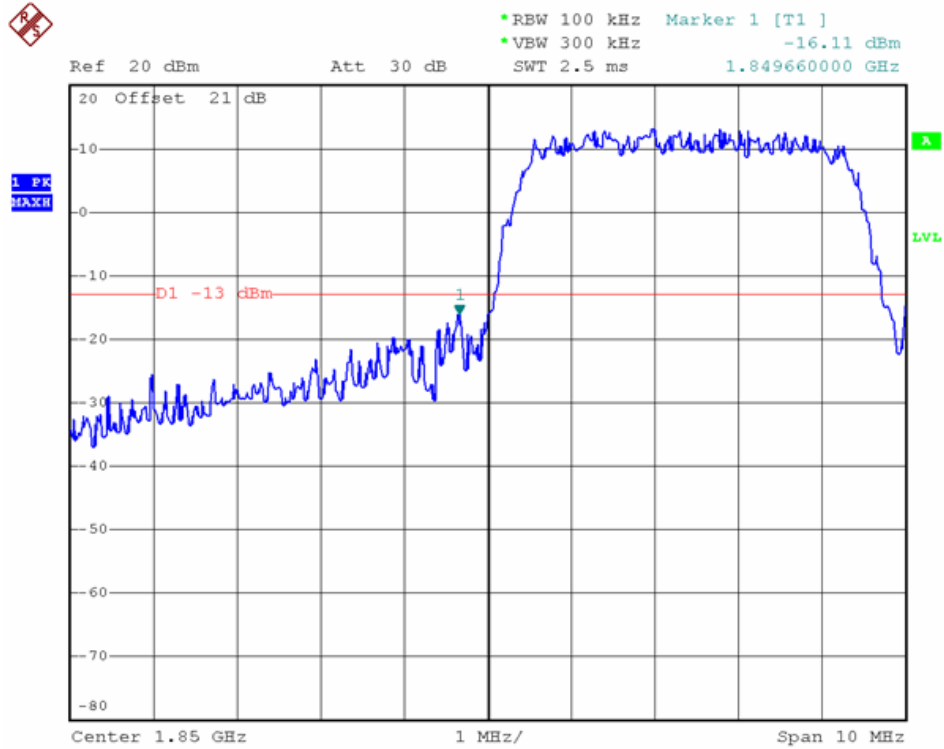

Channel 9538

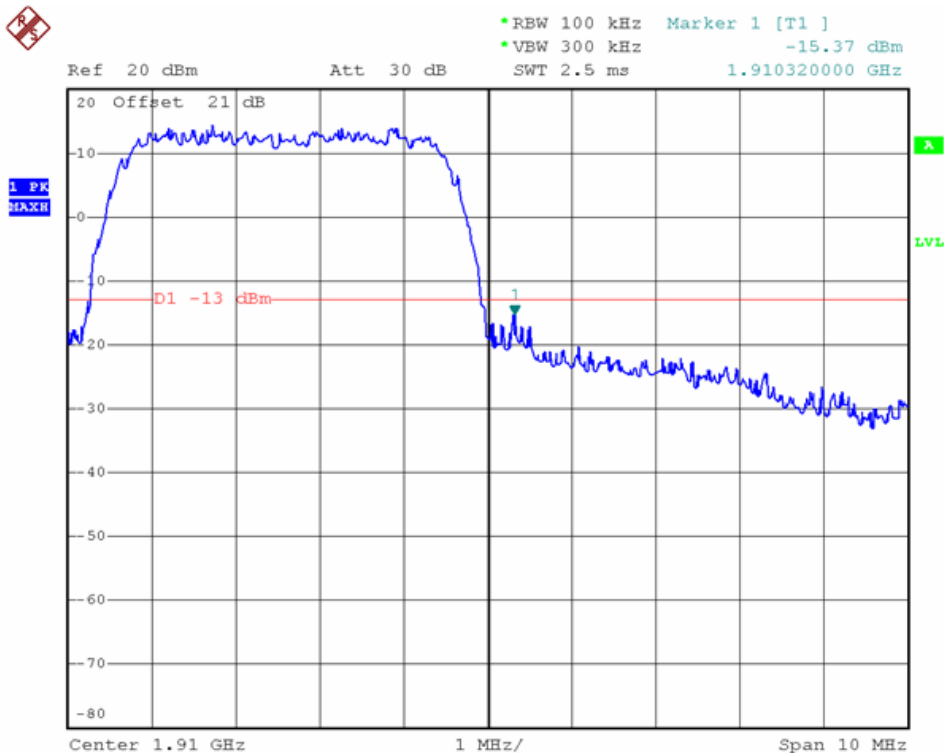



Test Item	Band Edge emissions
Test Mode	HSDPA 850
Test Date	2013-07-17

Channel 4132

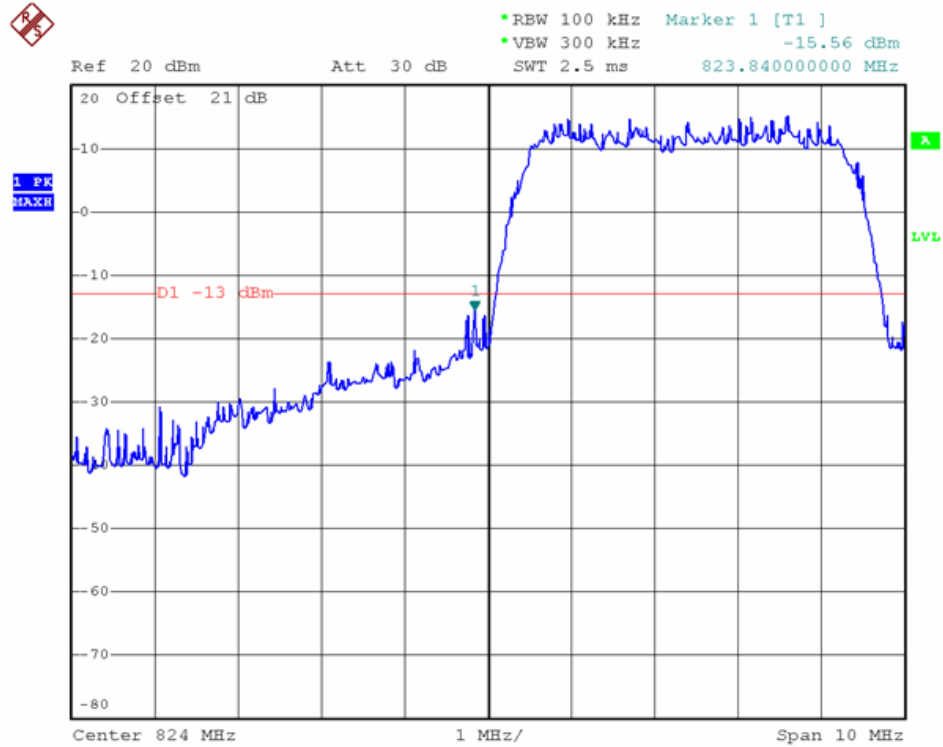

Channel 4233

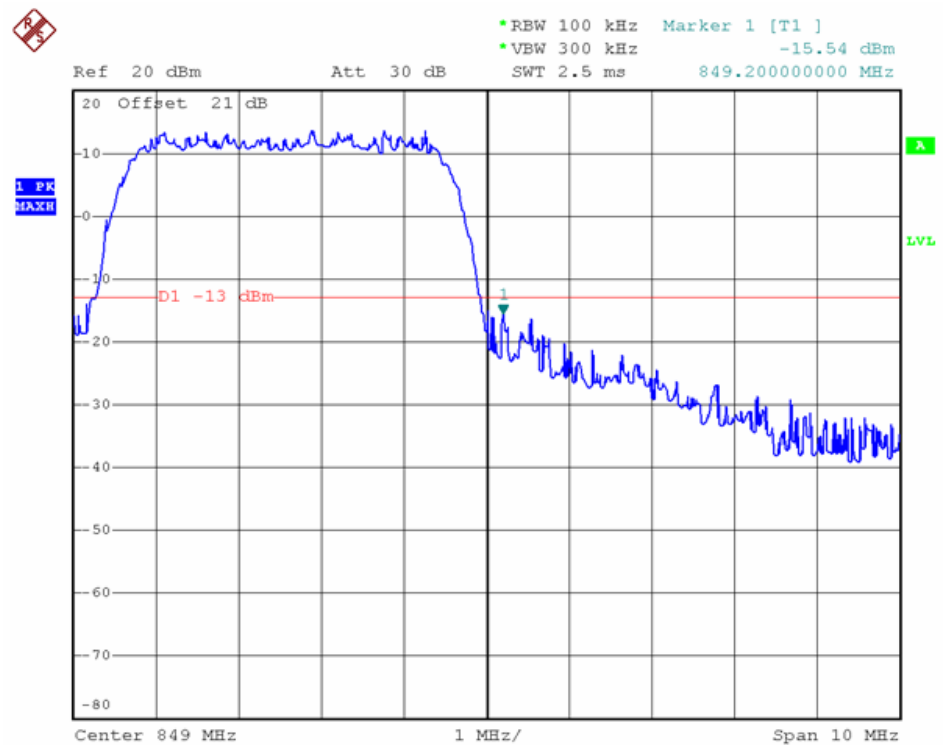



Test Item	Band Edge emissions
Test Mode	HSDPA 1900
Test Date	2013-07-17

Channel 9262

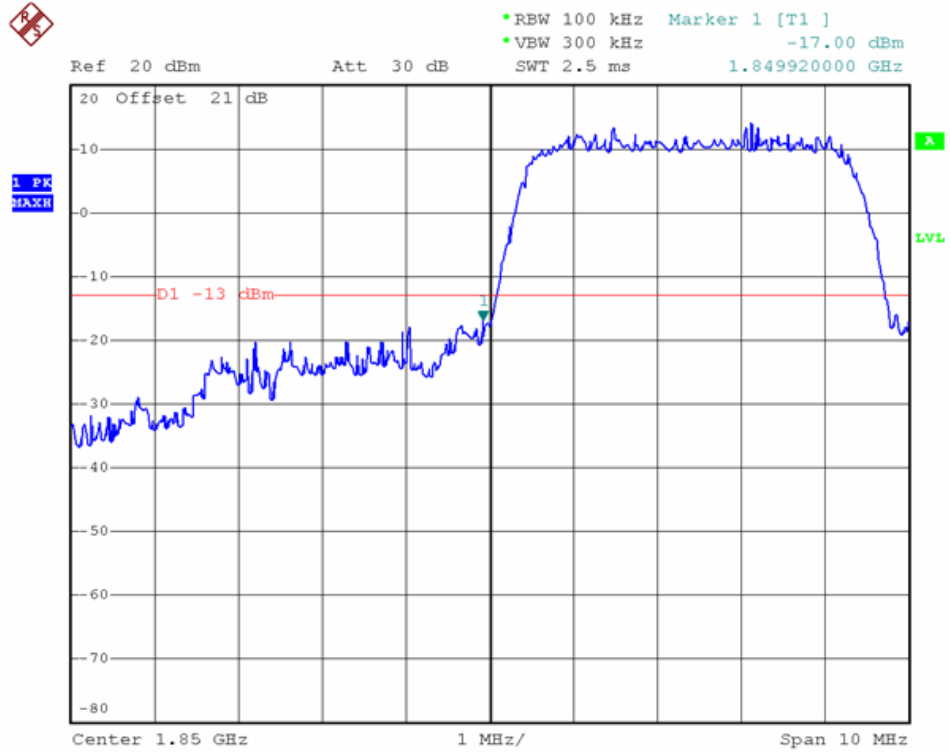

Channel 9538

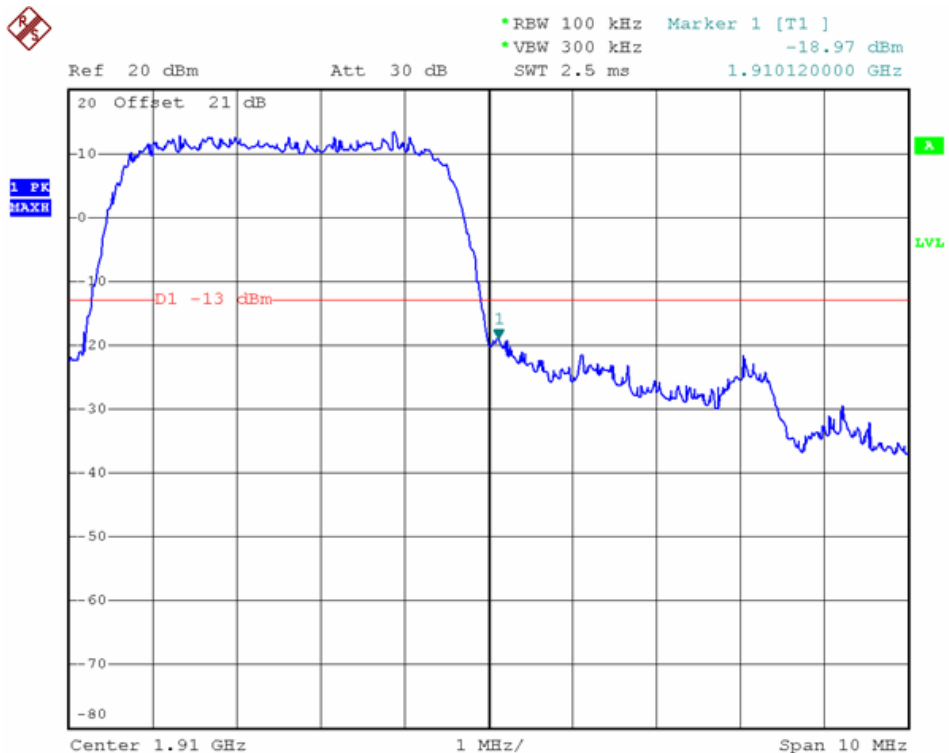



8. FREQUENCY STABILITY V.S. TEMPERATURE MEASUREMENT

8.1. Test Limit

According to FCC §2.1055, FCC §22.355, .FCC §24.235.

Frequency Tolerance: 2.5 ppm

8.2. Test Procedure

The equipment under test was connected to an external AC or DC power supply and input rated voltage. RF output was connected to a frequency counter or spectrum analyzer via feed through attenuators. The EUT was placed inside the temperature chamber. Set the spectrum analyzer RBW low enough to obtain the desired frequency resolution and measure EUT 20°C operating frequency as reference frequency. Turn EUT off and set the chamber temperature to -30°C. After the temperature stabilized for approximately 30 minutes recorded the frequency. Repeat step measure with 10°C increased per stage until the highest temperature of +50°C reached.

8.3. Test Setup Layout

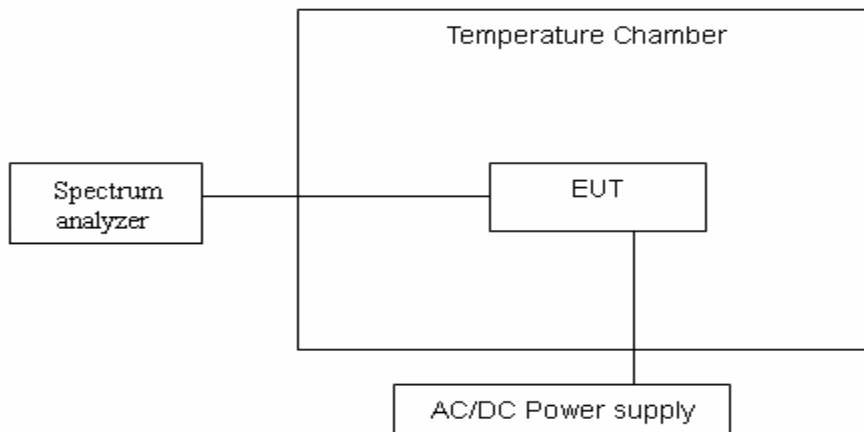

8.4. Measurement Equipment

Instrument/Ancillary	Model No.	Manufacturer	Serial No.	Calibration Date	Valid Date
Spectrum Analyzer	FSP40	R&S	100324	2013.03.10	2014.03.09
Temperature/ Humidity Meter	Zhicheng	ZC1-11	CEP-TH-002	2013.03.10	2014.03.09



8.5. Test Result and Data

Test Item	FREQUENCY STABILITY V.S. TEMPERATURE
Test Mode	HSUPA 850 Channel 4183
Test Date	2013-7-10

Reference Frequency: HSUPA Mid Channel 836.6 MHz @ 20°C				
Limit: +/- 2.5 ppm = 2090 Hz				
Power Supply Vac	Environment Temperature (°C)	Frequency (Hz)	Delta (Hz)	Limit (Hz)
12	50	83660024	50	2090
	40	83660022	48	
	30	83660032	58	
	20	83659974	0	
	10	83660028	54	
	0	83660009	35	
	-10	83660028	54	

Test Item	Power Spectral Density
Test Mode	HSUPA 1900 Channel 9440
Test Date	2013-7-10

Reference Frequency: HSUPA Mid Channel 1880 MHz @ 20°C				
Limit: ± 2.5 ppm = 4700 Hz				
Power Supply Vac	Environment Temperature (°C)	Frequency (Hz)	Delta (Hz)	Limit (Hz)
12	50	1880000045	88	4700
	40	1880000033	76	
	30	1880000049	92	
	20	1879999957	0	
	10	1880000042	85	
	0	1880000048	91	
	-10	1880000037	80	



Test Item	FREQUENCY STABILITY V.S. TEMPERATURE
Test Mode	HSDPA 850 Channel 4183
Test Date	2013-7-10

Reference Frequency: HSDPA Mid Channel 836.6 MHz @ 20°C				
Limit: +/- 2.5 ppm = 2090 Hz				
Power Supply Vac	Environment Temperature (°C)	Frequency (Hz)	Delta (Hz)	Limit (Hz)
12	50	83660029	63	2090
	40	83660033	67	
	30	83660041	75	
	20	83659966	0	
	10	83660030	64	
	0	83660021	55	
	-10	83660037	71	

Test Item	Power Spectral Density
Test Mode	HSDPA 1900 Channel 9400
Test Date	2013-7-10

Reference Frequency: HSDPA Mid Channel 1880 MHz @ 20°C				
Limit: ± 2.5 ppm = 4700 Hz				
Power Supply Vac	Environment Temperature (°C)	Frequency (Hz)	Delta (Hz)	Limit (Hz)
12	50	1880000039	87	4700
	40	1880000028	76	
	30	1880000041	89	
	20	1879999952	0	
	10	1880000034	82	
	0	1880000051	99	
	-10	1880000032	80	



9. REQUENCY STABILITY V.S. VOLTAGE MEASUREMENT

9.1. Test Limit

According to FCC §2.1055, FCC §22.355, .FCC §24.235.

9.2. Test Procedure

Set chamber temperature to 20°C. Use a variable AC power supply / DC power source to power the EUT and set the voltage to rated voltage. Set the spectrum analyzer RBW low enough to obtain the desired frequency resolution and recorded the frequency.

Reduce the input voltage to specify extreme voltage variation ($\pm 10\%$) and endpoint, record the maximum frequency change.

9.3. Test Setup Layout

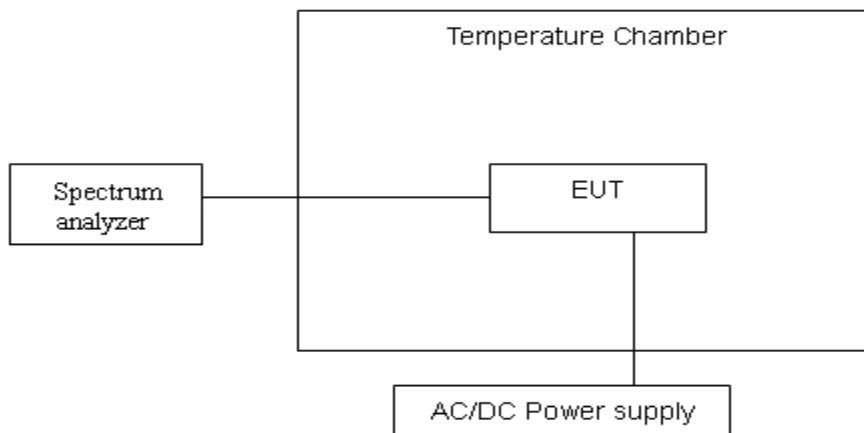

9.4. Measurement Equipment

Instrument/Ancillary	Model No.	Manufacturer	Serial No.	Calibration Date	Valid Date
Spectrum Analyzer	FSP40	R&S	100324	2013.03.10	2014.03.09
Temperature/ Humidity Meter	Zhicheng	ZC1-11	CEP-TH-002	2013.03.10	2014.03.09



9.5. Test Result and Data

Test Item	REQUENCY STABILITY V.S. VOLTAGE
Test Mode	HSUPA 850 Channel 4183
Test Date	2013-7-10

Reference Frequency: HSUPA Mid Channel 836.6 MHz @ 20°C				
Limit: ± 2.5 ppm = 2090Hz				
Power Supply Vac	Environment Temperature (°C)	Frequency (Hz)	Delta (Hz)	Limit (Hz)
13.2	20	835999871	5	2090
12		835999866	0	
10.8		835999869	3	

Test Item	Power Spectral Density
Test Mode	HSUPA 1900 Channel 9400
Test Date	2013-7-10

Reference Frequency: HSUPA Mid Channel 1880 MHz @ 20°C				
Limit: ± 2.5 ppm = 4700 Hz				
Power Supply Vac	Environment Temperature (°C)	Frequency (Hz)	Delta (Hz)	Limit (Hz)
13.2	20	1879999953	-2	4700
12		1879999955	0	
10.8		1879999949	-6	



Test Item	REQUENCY STABILITY V.S. VOLTAGE
Test Mode	HSDPA 850 Channel 4183
Test Date	2013-7-10

Reference Frequency: HSDPA Mid Channel 836.6 MHz @ 20°C				
Limit: ± 2.5 ppm = 2090Hz				
Power Supply Vac	Environment Temperature (°C)	Frequency (Hz)	Delta (Hz)	Limit (Hz)
13.2	20	835999875	6	2090
12		835999869	0	
10.8		835999874	5	

Test Item	Power Spectral Density
Test Mode	HSDPA 1900 Channel 9400
Test Date	2013-7-10

Reference Frequency: HSDPA Mid Channel 1880 MHz @ 20°C				
Limit: ± 2.5 ppm = 4700 Hz				
Power Supply Vac	Environment Temperature (°C)	Frequency (Hz)	Delta (Hz)	Limit (Hz)
13.2	20	1879999955	-4	4700
12		1879999959	0	
10.8		1879999951	-8	