



# FCC SAR TEST REPORT

Report No.: STS2208326H02

Issued for

Trackimo INC.

680 Central Ave, Cedarhurst, New York 11516, USA

<b>Product Name:</b>	GPS Tracker
<b>Brand Name:</b>	Trackimo
<b>Model Name:</b>	TRKM110-T
<b>Series Model:</b>	N/A
<b>FCC ID:</b>	2AAI6-TRKM110-T
<b>Test Standard:</b>	ANSI/IEEE Std. C95.1
	FCC 47 CFR Part 2 ( 2.1093)
	IEEE 1528: 2013
<b>Max. Report SAR (1g):</b>	Body: 1.231 W/kg

Any reproduction of this document must be done in full. No single part of this document may be reproduced without permission from STS, All Test Data Presented in this report is only applicable to presented Test sample.

ShenZhen STS Test Services Co.,Ltd.

A 1/F, Building B, Zhuoke Science Park, No.190 Chongqing Road, HepingShequ, Fuyong Sub-District, Bao'an District, Shenzhen, Guang Dong, China

TEL: +86-755 3688 6288 FAX: +86-755 3688 6277 E-mail:sts@ststest.com





### Test Report Certification

**Applicant's name** ..... : Trackimo INC.  
 Address ..... : 680 Central Ave, Cedarhurst, New York 11516, USA  
**Manufacturer's Name** ..... : Trackimo INC.  
 Address ..... : 680 Central Ave, Cedarhurst, New York 11516, USA

#### Product description

Product name ..... : GPS Tracker  
 Brand name ..... : Trackimo  
 Model name ..... : TRKM110-T  
 Series Model..... : N/A  
 Standards ..... : ANSI/IEEE Std. C95.1-1992  
                               : FCC 47 CFR Part 2 ( 2.1093)  
                               : IEEE 1528: 2013

The device was tested by Shenzhen STS Test Services Co., Ltd. in accordance with the measurement methods and procedures specified in KDB 865664 The test results in this report apply only to the tested sample of the stated device/equipment. Other similar device/equipment will not necessarily produce the same results due to production tolerance and measurement uncertainties.

**Date of Test** ..... :  
 Date (s) of performance of tests ..... : 16 Aug. 2022 ~ 26 Sept. 2022  
 Date of Issue..... : 18 Oct. 2022  
 Test Result..... : **Pass**

Testing Engineer : Shi fan-long  
 (Shifan. Long)

Technical Manager : Sean She  
 (Sean she)

Authorized Signatory : Bovey Yang  
 (Bovey Yang)





## Table of Contents

<b>1. General Information</b>	<b>5</b>
1.1 EUT Description	5
1.2 Test Environment	7
1.3 Test Factory	7
<b>2. Test Standards and Limits</b>	<b>8</b>
<b>3. SAR Measurement System</b>	<b>9</b>
3.1 Definition of Specific Absorption Rate (SAR)	9
3.2 SAR System	9
<b>4. Tissue Simulating Liquids</b>	<b>12</b>
4.1 Simulating Liquids Parameter Check	12
<b>5. SAR System Validation</b>	<b>15</b>
5.1 Validation System	15
5.2 Validation Result	15
<b>6. SAR Evaluation Procedures</b>	<b>16</b>
<b>7. EUT Antenna Location Sketch</b>	<b>17</b>
7.1 SAR test exclusion consider table	18
<b>8. EUT Test Position</b>	<b>23</b>
8.1 Body-worn Position Conditions	23
<b>9. Uncertainty</b>	<b>24</b>
9.1 Measurement Uncertainty	24
<b>10. Conducted Power Measurement</b>	<b>25</b>
10.1 Test Result	25
<b>11. EUT and Test Setup Photo</b>	<b>53</b>
11.1 EUT Photo	53
11.2 Setup Photo	56
<b>12. SAR Result Summary</b>	<b>59</b>
12.1 Body-worn and Hotspot SAR	59
<b>13. Equipment List</b>	<b>67</b>
<b>Appendix A. System Validation Plots</b>	<b>68</b>
<b>Appendix B. SAR Test Plots</b>	<b>78</b>
<b>Appendix C. Probe Calibration and Dipole Calibration Report</b>	<b>92</b>



**Revision History**

Rev.	Issue Date	Report No.	Effect Page	Contents
00	18 Oct. 2022	STS2208326H02	ALL	Initial Issue





## 1. General Information

Environmental evaluation measurements of specific absorption rate (SAR) distributions in emulated human head and body tissues exposed to radio frequency (RF) radiation from wireless portable devices for compliance with the rules and regulations of the U.S. Federal Communications Commission (FCC).

### 1.1 EUT Description

Product Name	GPS Tracker
Brand Name	Trackimo
Model Name	TRKM110-T
Series Model	N/A
Model Difference	N/A
Battery	Rated Voltage:3.7V Charge Limit Voltage:4.2V Capacity: 10000mAh
Device Category	Portable
Product stage	Production unit
RF Exposure Environment	General Population / Uncontrolled
Hardware Version	UG02 PCB V0.3
Software Version	UG02 V0.1
Frequency Range	GSM 850: 824 MHz ~ 849 MHz PCS1900: 1850 MHz ~ 1910 MHz WCDMA Band II: 1850 MHz ~ 1910 MHz WCDMA Band V: 824 MHz ~ 849 MHz LTE Band 2: 1850MHz to 1910 MHz LTE Band 4: 1710 MHz to 1755 MHz LTE Band 5: 824 MHz~849 MHz LTE Band 7: 2500 MHz to 2570 MHz LTE Band 12: 699MHz to 716 MHz LTE Band 13: 777 MHz ~ 787 MHz LTE Band 17: 704 MHz ~ 716 MHz LTE Band 25: 1850MHz to 1915 MHz LTE Band 26: 814 MHz ~ 849 MHz LTE Band 41: 2555 MHz ~ 2655 MHz Bluetooth: 2402 MHz to 2480 MHz



	Band	Mode	Body (W/kg)
Max. Reported SAR(1g): (Limit:1.6W/kg)	PCB	GSM 850	0.255
	PCB	GSM 1900	1.231
	PCB	WCDMA Band II	0.592
	PCB	WCDMA Band V	0.166
	PCB	LTE Band 2	0.501
	PCB	LTE Band 4	0.496
	PCB	LTE Band 5	0.197
	PCB	LTE Band 7	1.064
	PCB	LTE Band 12	0.253
	PCB	LTE Band 13	0.769
	PCB	LTE Band 17	0.232
	PCB	LTE Band 25	0.515
	PCB	LTE Band 26	0.249
	PCB	LTE Band 41	0.312
DSS BT			0.343
1-g Sum SAR			1.574
FCC Equipment Class	Licensed Portable Transmitter (PCB) Digital Transmission System (DTS)		
Operating Mode:	GSM: GSM Voice; GPRS/EGPRS Class 12 WCDMA: RMC, HSDPA, HSUPA Release 6 LTE: QPSK, 16QAM BLE: GFSK		
Antenna Specification:	GSM/WCDMA/LTE: PIFA Antenna Bluetooth: PIFA Antenna		
SIM Card	Only one SIM card is supported.		
Hotspot Mode	Does not support		
DTM Mode	Not Support		
Note:			
1. The EUT battery must be fully charged and checked periodically during the test to ascertain uniform power			
2. Bluetooth SAR was estimated			



## 1.2 Test Environment

Ambient conditions in the SAR laboratory:

Items	Required
Temperature (°C)	18-25
Humidity (%RH)	30-70

## 1.3 Test Factory

ShenZhen STS Test Services Co.,Ltd.

A 1/F, Building B, Zhuoke Science Park, No.190 Chongqing Road, HepingShequ, Fuyong Sub-District, Bao'an District, Shenzhen, Guang Dong, China

FCC test Firm Registration No.: 625569

IC Registration No.: 12108A

A2LA Certificate No.: 4338.01





## 2. Test Standards and Limits

No.	Identity	Document Title
1	47 CFR Part 2	Frequency Allocations and Radio Treaty Matters; General Rules and Regulations
2	ANSI/IEEE Std. C95.1-1992	IEEE Standard for Safety Levels with Respect to Human Exposure to Radio Frequency Electromagnetic Fields, 3 kHz to 300 GHz
3	IEEE Std. 1528-2013	Recommended Practice for Determining the Peak Spatial-Average Specific Absorption Rate (SAR) in the Human Head from Wireless Communications Devices: Measurement Techniques
4	FCC KDB 447498 D04 v01	RF Exposure Procedures and Equipment Authorization Policies for Mobile and Portable Devices
5	FCC KDB 865664 D01 v01r04	SAR Measurement 100 MHz to 6 GHz
6	FCC KDB 865664 D02 v01r02	RF Exposure Reporting
7	FCC KDB 941225 D01 v03r01	SAR Measurement Procedures for 3G Devices
8	FCC KDB 941225 D05 v02r05	SAR for LTE Devices

(A). Limits for Occupational/Controlled Exposure (W/kg)

Whole-Body	Partial-Body	Hands, Wrists, Feet and Ankles
0.4	8.0	20.0

(B). Limits for General Population/Uncontrolled Exposure (W/kg)

Whole-Body	Partial-Body	Hands, Wrists, Feet and Ankles
0.08	1.6	4.0

NOTE: Whole-Body SAR is averaged over the entire body, partial-body SAR is averaged over any 1 gram of tissue defined as a tissue volume in the shape of a cube. SAR for hands, wrists, feet and ankles is averaged over any 10 grams of tissue defined as a tissue volume in the shape of a cube.

**Population/Uncontrolled Environments:**

Are defined as locations where there is the exposure of individuals who have no knowledge or control of their exposure.

**Occupational/Controlled Environments:**

Are defined as locations where there is exposure that may be incurred by people who are aware of the potential for exposure, (i.e. as a result of employment or occupation).

<p><b>NOTE</b></p> <p><b>GENERAL POPULATION/UNCONTROLLED EXPOSURE</b></p> <p><b>PARTIAL BODY LIMIT</b></p> <p><b>1.6 W/kg</b></p>
---



### 3. SAR Measurement System

#### 3.1 Definition of Specific Absorption Rate (SAR)

SAR is related to the rate at which energy is absorbed per unit mass in an object exposed to a radio field. The SAR distribution in a biological body is complicated and is usually carried out by experimental techniques or numerical modeling. The standard recommends limits for two tiers of groups, occupational/controlled and general population/uncontrolled, based on a person's awareness and ability to exercise control over his or her exposure. In general, occupational/controlled exposure limits are higher than the limits for general population/uncontrolled.

The SAR definition is the time derivative (rate) of the incremental energy (dW) absorbed by (dissipated in) an incremental mass (dm) contained in a volume element (dv) of a given density (ρ). The equation description is as below:

$$SAR = \frac{d}{dt} \left( \frac{dW}{dm} \right) = \frac{d}{dt} \left( \frac{dW}{\rho dv} \right)$$

SAR is expressed in units of Watts per kilogram (W/kg) SAR measurement can be related to the electrical field in the tissue by

$$SAR = \frac{\sigma E^2}{\rho}$$

Where: σ is the conductivity of the tissue,  
ρ is the mass density of the tissue and E is the RMS electrical field strength.

#### 3.2 SAR System

MVG SAR System Diagram:

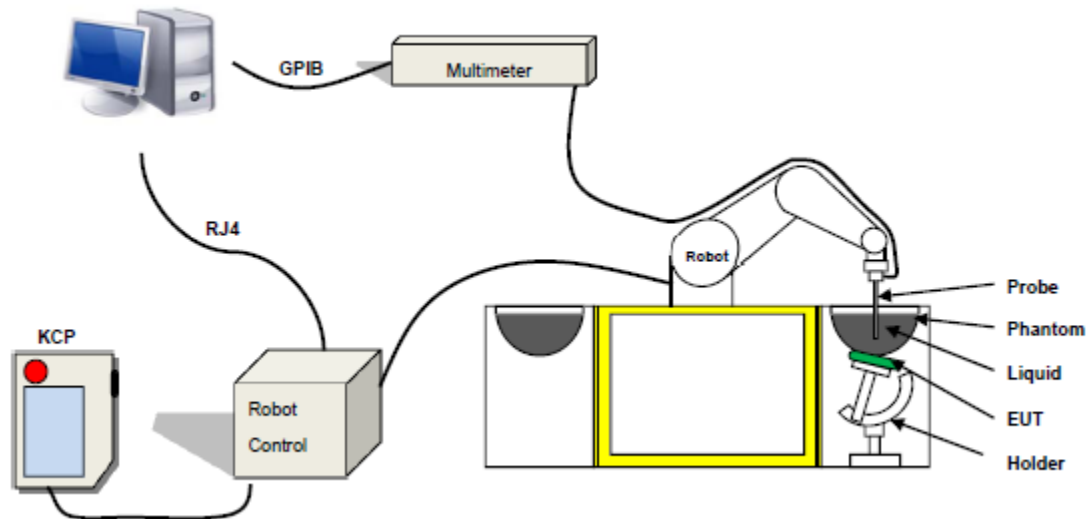

COMOSAR is a system that is able to determine the SAR distribution inside a phantom of human being according to different standards. The COMOSAR system consists of the following items:

- Main computer to control all the system
- 6 axis robot
- Data acquisition system
- Miniature E-field probe
- Phone holder
- Head simulating tissue

The following figure shows the system.



The EUT under test operating at the maximum power level is placed in the phone holder, under the phantom, which is filled with head simulating liquid. The E-Field probe measures the electric field inside the phantom. The Open SAR software computes the results to give a SAR value in a 1g or 10g mass.

### 3.2.1 Probe

For the measurements the Specific Dosimetric E-Field Probe SN 07/21 EPGO352 with following specifications is used

- Probe Length: 330 mm
- Length of Individual Dipoles: 2 mm
- Maximum external diameter: 8 mm
- Probe Tip External Diameter: 2.5 mm
- Distance between dipole/probe extremity: 1 mm
- Dynamic range: 0.01-100 W/kg
- Probe linearity: 3%
- Axial Isotropy: < 0.10 dB
- Spherical Isotropy: < 0.10 dB
- Calibration range: 150 MHz to 6 GHz for head & body simulating liquid.
- Angle between probe axis (evaluation axis) and surface normal line: less than 30°



Figure 1-MVG COMOSAR Dosimetric E field Dipole

### 3.2.2 Phantom

For the measurements the Specific Anthropomorphic Mannequin (SAM) defined by the IEEE SCC-34/SC2 group is used. The phantom is a polyurethane shell integrated in a wooden table. The thickness of the phantom amounts to 2mm +/- 0.2mm. It enables the dosimetric evaluation of left and right phone usage and includes an additional flat phantom part for the simplified performance check. The phantom set-up includes a cover, which prevents the evaporation of the liquid.

SN 32/14 SAM115



Figure-SN 21/21 ELLI48



### 3.2.3 Device Holder

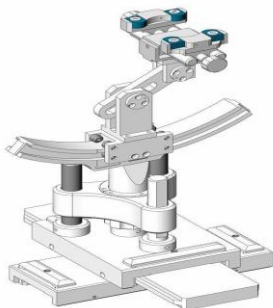

The SAR in the phantom is approximately inversely proportional to the square of the distance between the source and the liquid surface. For a source at 5 mm distance, a positioning uncertainty of  $\pm 0.5$  mm would produce a SAR uncertainty of  $\pm 20$  %. Accurate device positioning is therefore crucial for accurate and repeatable measurements. The positions in which the devices must be measured are defined by the standards.

### 4. Tissue Simulating Liquids



## 4. Tissue Simulating Liquids

### 4.1 Simulating Liquids Parameter Check

The head tissue dielectric parameters recommended by the IEEE SCC-34/SC-2 in P1528 have been incorporated in the following table. These head parameters are derived from planar layer models simulating the highest expected SAR for the dielectric properties and tissue thickness variations in a human head. Other head and body tissue parameters that have not been specified in P1528 are derived from the tissue dielectric parameters computed from the 4-Cole-Cole equations described in Reference [12] and extrapolated according to the head parameters specified in P1528.

#### Head Tissue

Frequency (MHz)	cellulose	DGBE	HEC	NaCl	Preventol	Sugar	X100	Water	Conductivity	Permittivity
	%	%	%	%	%	%	%	%	$\sigma$	$\epsilon_r$
750	0.2	/	/	1.4	0.2	57.0	/	41.1	0.89	41.9
835	0.2	/	/	1.4	0.2	57.9	/	40.3	0.90	41.5
900	0.2	/	/	1.4	0.2	57.9	/	40.3	0.97	41.5
1800	/	44.5	/	0.3	/	/	30.45	55.2	1.4	40.0
1900	/	44.5	/	0.3	/	/	30.45	55.2	1.4	40.0
2000	/	44.5	/	0.3	/	/	/	55.2	1.4	40.0
2450	/	44.9	/	0.1	/	/	/	55.0	1.80	39.2
2600	/	45.0	/	0.1	/	/	/	54.9	1.96	39.0

#### Body Tissue

Frequency (MHz)	cellulose	DGBE	HEC	NaCl	Preventol	Sugar	X100	Water	Conductivity	Permittivity
	%	%	%	%	%	%	%	%	$\sigma$	$\epsilon_r$
750	0.2	/	/	0.9	0.1	47.2	/	51.7	0.96	55.5
835	0.2	/	/	0.9	0.1	48.2	/	50.8	0.97	55.2
900	0.2	/	/	0.9	0.1	48.2	/	50.8	1.05	55.0
1800	/	29.4	/	0.4	/	/	30.45	70.2	1.52	53.3
1900	/	29.4	/	0.4	/	/	30.45	70.2	1.52	53.3
2000	/	29.4	/	0.4	/	/	/	70.2	1.52	53.3
2450	/	31.3	/	0.1	/	/	/	68.6	1.95	52.7
2600	/	31.7	/	0.1	/	/	/	68.2	2.16	52.3

Tissue dielectric parameters for head and body phantoms				
Frequency	$\epsilon_r$		$\sigma$ S/m	
	Head	Body	Head	Body
	300	45.3	58.2	0.87
450	43.5	56.7	0.87	0.94
900	41.5	55.0	0.97	1.05
1450	40.5	54.0	1.20	1.30
1800	40.0	53.3	1.40	1.52
2450	39.2	52.7	1.80	1.95
3000	38.5	52.0	2.40	2.73
5800	35.3	48.2	5.27	6.00



**LIQUID MEASUREMENT RESULTS**

Date	Ambient		Simulating Liquid		Parameters	Target	Measured	Deviation %	Limited %
	Temp. [°C]	Humidity %	Frequency (MHz)	Temp. [°C]					
2022-08-16	20.8	60	704	20.5	Permittivity	42.15	42.66	1.21	±5
					Conductivity	0.89	0.90	1.12	±5
2022-08-16	20.9	60	709	20.7	Permittivity	42.12	42.92	1.90	±5
					Conductivity	0.89	0.90	1.12	±5
2022-08-16	20.9	61	711	20.6	Permittivity	42.11	42.69	1.38	±5
					Conductivity	0.89	0.91	2.25	±5
2022-08-16	20.9	61	750	20.6	Permittivity	41.90	42.02	0.29	±5
					Conductivity	0.89	0.82	-7.87	±5
2022-08-16	21.0	61	782	20.7	Permittivity	41.73	42.77	2.49	±5
					Conductivity	0.89	0.88	-1.12	±5
2022-08-18	20.8	42	824.2	20.4	Permittivity	41.55	42.25	1.68	±5
					Conductivity	0.90	0.92	2.22	±5
2022-08-18	20.9	42	835	20.6	Permittivity	41.50	41.25	-0.60	±5
					Conductivity	0.90	0.93	3.33	±5
2022-08-18	20.9	42	836.5	20.7	Permittivity	41.49	41.23	-0.63	±5
					Conductivity	0.90	0.94	4.44	±5
2022-08-18	20.8	42	836.6	20.5	Permittivity	41.49	40.62	-2.10	±5
					Conductivity	0.90	0.93	3.33	±5
2022-08-18	21.0	43	841.5	20.7	Permittivity	41.47	41.09	-0.92	±5
					Conductivity	0.90	0.86	-4.44	±5
2022-08-18	20.9	42	844	20.5	Permittivity	41.46	41.23	-0.55	±5
					Conductivity	0.90	0.88	-2.22	±5
2022-09-20	22.0	56	1720	21.8	Permittivity	40.11	40.79	1.70	±5
					Conductivity	1.35	1.32	-2.22	±5
2022-09-20	22.1	56	1732.5	21.8	Permittivity	40.10	41.15	2.62	±5
					Conductivity	1.36	1.35	-0.74	±5
2022-09-20	22.2	56	1800	22.0	Permittivity	40.00	41.13	2.83	±5
					Conductivity	1.40	1.42	1.43	±5
2022-09-23	22.2	45	1850.2	21.9	Permittivity	40.00	41.16	2.90	±5
					Conductivity	1.40	1.41	0.71	±5
2022-09-23	22.3	56	1852.4	22.0	Permittivity	40.00	40.66	1.65	±5
					Conductivity	1.40	1.36	-2.86	±5





2022-09-23	22.3	56	1860	22.0	Permittivity	40.00	40.22	0.55	±5
					Conductivity	1.40	1.36	-2.86	±5
2022-09-23	22.3	45	1880	22.0	Permittivity	40.00	40.07	0.18	±5
					Conductivity	1.40	1.39	-0.71	±5
2022-09-23	22.4	57	1900	22.2	Permittivity	40.00	41.05	2.62	±5
					Conductivity	1.40	1.35	-3.57	±5
2022-09-23	22.3	45	1909.8	22.0	Permittivity	40.00	40.43	1.08	±5
					Conductivity	1.40	1.44	2.86	±5
2022-09-26	23.6	51	2560	23.4	Permittivity	39.05	39.44	1.00	±5
					Conductivity	1.92	1.94	1.04	±5
2022-09-26	23.6	51	2593	23.3	Permittivity	39.01	39.98	2.49	±5
					Conductivity	1.95	2.01	3.08	±5
2022-09-26	23.6	52	2600	23.3	Permittivity	39.00	39.48	1.23	±5
					Conductivity	1.96	1.99	1.53	±5



## 5. SAR System Validation

### 5.1 Validation System

Each MVG system is equipped with one or more system validation kits. These units, together with the predefined measurement procedures within the MVG software, enable the user to conduct the system performance check and system validation. System kit includes a dipole, and dipole device holder. The system check verifies that the system operates within its specifications. It's performed daily or before every SAR measurement. The system check uses normal SAR measurement in the flat section of the phantom with a matched dipole at a specified distance. The system validation setup is shown as below.

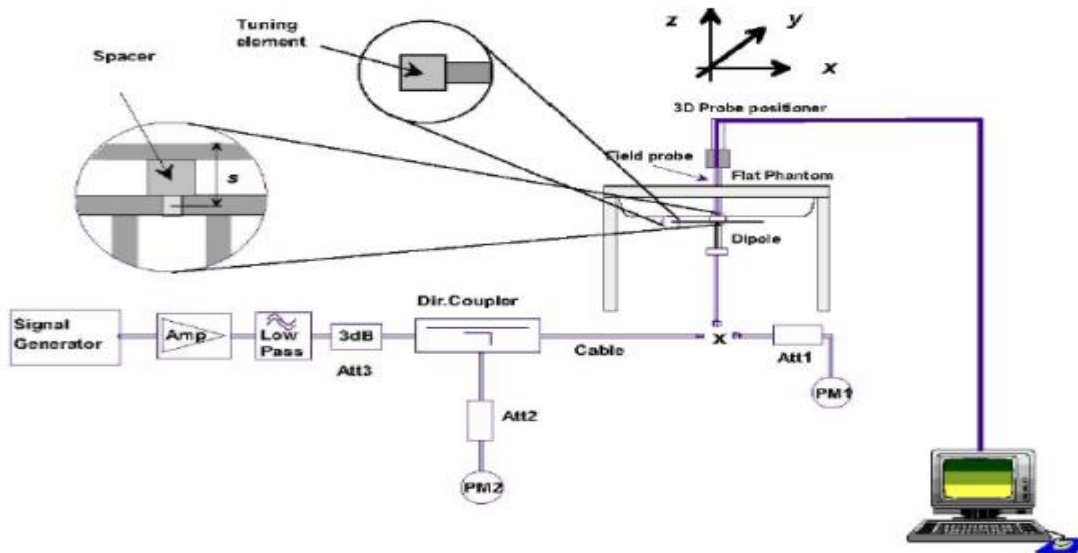

### 5.2 Validation Result

Comparing to the original SAR value provided by MVG, the validation data should be within its specification of 10 %.

Date	Freq.	Power	Tested Value	Normalized SAR	Target SAR	Tolerance	Limit
	(MHz)	(mW)	(W/Kg)	(W/kg)	1g(W/kg)	(%)	(%)
2022-08-16	750	100	0.883	8.83	8.49	4.00	10
2022-08-18	835	100	0.951	9.51	9.56	-0.52	10
2022-09-20	1800	100	3.799	37.99	38.40	-1.07	10
2022-09-23	1900	100	3.967	39.67	39.70	-0.08	10
2022-09-26	2600	100	5.543	55.43	55.30	0.24	10

Note:

1. The tolerance limit of System validation  $\pm 10\%$ .
2. The dipole input power (forward power) was 100 mW.
3. The results are normalized to 1 W input power.



## 6. SAR Evaluation Procedures

The procedure for assessing the average SAR value consists of the following steps:

The following steps are used for each test position

- Establish a call with the maximum output power with a base station simulator. The connection between the mobile and the base station simulator is established via air interface
- Measurement of the local E-field value at a fixed location. This value serves as a reference value for calculating a possible power drift.
- Measurement of the SAR distribution with a grid of 8 to 16mm \* 8 to 16 mm and a constant distance to the inner surface of the phantom. Since the sensors cannot directly measure at the inner phantom surface, the values between the sensors and the inner phantom surface are extrapolated. With these values the area of the maximum SAR is calculated by an interpolation scheme.
- Around this point, a cube of 30 \* 30 \* 30 mm or 32 \* 32 \* 32 mm is assessed by measuring 5 or 8 \* 5 or 8\*4 or 5 mm. With these data, the peak spatial-average SAR value can be calculated.

### ➤ Area Scan & Zoom Scan

First Area Scan is used to locate the approximate location(s) of the local peak SAR value(s). The measurement grid within an Area Scan is defined by the grid extent, grid step size and grid offset. Next, in order to determine the EM field distribution in a three-dimensional spatial extension, Zoom Scan is required. The Zoom Scan is performed around the highest E-field value to determine the averaged SAR-distribution over 10 g. Area scan and zoom scan resolution setting follows KDB 865664 D01 quoted below. When the 1-g SAR of the highest peak is within 2 dB of the SAR limit, additional zoom scans are required for other peaks within 2 dB of the highest peak that have not been included in any zoom scan to ensure there is no increase in SAR.



## 7. EUT Antenna Location Sketch

It is a GPS Tracker, support GSM/WCDMA/LTE/BT mode.

Top side

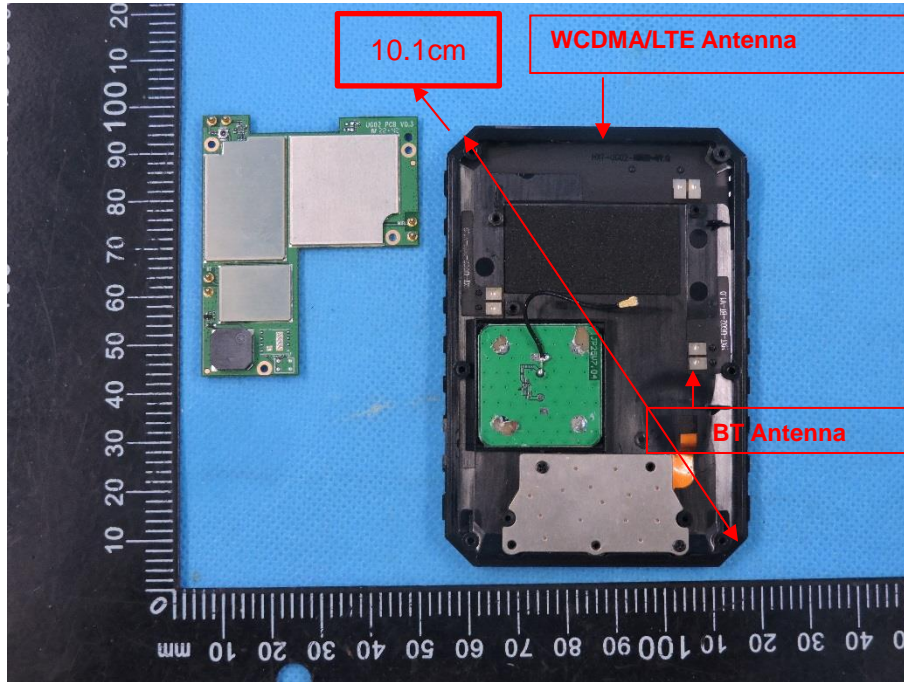

Antenna Separation Distance(cm)

ANT	Back Side	Front Side	Left Side	Right Side	Top Side	Bottom Side
WWAN	≤0.5	≤0.5	1	≤0.5	7.5	≤0.5
BLE	≤0.5	≤0.5	5.1	≤0.5	3.5	4.2

Note 1: The antenna information refer the manufacturer provide report, applicable only to the tested sample identified in the report.



### 7.1 SAR test exclusion consider table

The WWAN/BT SAR evaluation of Maximum power (dBm) summing tolerance.

Exposure Position	Wireless Interface	GSM850	PCS1900	WCDMA II	WCDMA V	LTE Band 2
	Calculated Frequency(GHz)	0.8242	1.8502	1.8524	0.8366	1.86
	Maximum Turn-up power (dBm)	31	26	20.5	23	23
	Maximum rated power(mW)	1258.93	398.11	112.20	199.53	199.53
Back Side	Separation distance (cm)	≤0.5	≤0.5	≤0.5	≤0.5	≤0.5
	exclusion threshold(mW)	9.42	3.44	3.43	9.22	3.42
	Testing required?	YES	YES	YES	YES	YES
Front Side	Separation distance (cm)	≤0.5	≤0.5	≤0.5	≤0.5	≤0.5
	exclusion threshold(mW)	9.42	3.44	3.43	9.22	3.42
	Testing required?	YES	YES	YES	YES	YES
Left Side	Separation distance (cm)	1	1	1	1	1
	exclusion threshold(mW)	24.95	12.31	12.30	24.60	12.27
	Testing required?	YES	YES	YES	YES	YES
Right Side	Separation distance (cm)	≤0.5	≤0.5	≤0.5	≤0.5	≤0.5
	exclusion threshold(mW)	9.42	3.44	3.43	9.22	3.42
	Testing required?	YES	YES	YES	YES	YES
Top Side	Separation distance (cm)	7.5	7.5	7.5	7.5	7.5
	exclusion threshold(mW)	423.60	502.85	502.72	425.89	502.28
	Testing required?	YES	NO	NO	NO	NO
Bottom Side	Separation distance (cm)	≤0.5	≤0.5	≤0.5	≤0.5	≤0.5
	exclusion threshold(mW)	9.42	3.44	3.43	9.22	3.42
	Testing required?	YES	YES	YES	YES	YES



Exposure Position	Wireless Interface	LTE Band 4	LTE Band 5	LTE Band 7	LTE Band 12	LTE Band 13
	Calculated Frequency(GHz)	1.745	0.8365	2.56	0.711	0.782
	Maximum Turn-up power (dBm)	23.5	24	23	24	21
	Maximum rated power(mW)	223.87	251.19	199.53	251.19	125.89
Back Side	Separation distance (cm)	≤0.5	≤0.5	≤0.5	≤0.5	≤0.5
	exclusion threshold(mW)	3.60	9.22	2.65	11.59	10.14
	Testing required?	YES	YES	YES	YES	YES
Front Side	Separation distance (cm)	≤0.5	≤0.5	≤0.5	≤0.5	≤0.5
	exclusion threshold(mW)	3.60	9.22	2.65	11.59	10.14
	Testing required?	YES	YES	YES	YES	YES
Left Side	Separation distance (cm)	1	1	1	1	1
	exclusion threshold(mW)	12.79	24.60	9.97	28.71	26.23
	Testing required?	YES	YES	YES	YES	YES
Right Side	Separation distance (cm)	≤0.5	≤0.5	≤0.5	≤0.5	≤0.5
	exclusion threshold(mW)	3.60	9.22	2.65	11.59	10.14
	Testing required?	YES	YES	YES	YES	YES
Top Side	Separation distance (cm)	7.5	7.5	7.5	7.5	7.5
	exclusion threshold(mW)	509.16	425.87	469.25	401.59	415.63
	Testing required?	NO	NO	NO	NO	NO
Bottom Side	Separation distance (cm)	≤0.5	≤0.5	≤0.5	≤0.5	≤0.5
	exclusion threshold(mW)	3.60	9.22	2.65	11.59	10.14
	Testing required?	YES	YES	YES	YES	YES



Exposure Position	Wireless Interface	LTE Band 17	LTE Band 25	LTE Band 26	LTE Band 41	BLE
	Calculated Frequency(GHz)	0.711	1.86	0.8415	2.68	2.44
	Maximum Turn-up power (dBm)	24	24	23.5	22	-2.3
	Maximum rated power(mW)	251.19	251.19	223.87	158.49	0.59
Back Side	Separation distance (cm)	≤0.5	≤0.5	≤0.5	≤0.5	≤0.5
	exclusion threshold(mW)	11.59	3.42	9.15	2.55	2.75
	Testing required?	YES	YES	YES	YES	NO
Front Side	Separation distance (cm)	≤0.5	≤0.5	≤0.5	≤0.5	≤0.5
	exclusion threshold(mW)	11.59	3.42	9.15	2.55	2.75
	Testing required?	YES	YES	YES	YES	NO
Left Side	Separation distance (cm)	1	1	1	1	5.1
	exclusion threshold(mW)	28.71	12.27	24.46	9.67	227.72
	Testing required?	YES	YES	YES	YES	NO
Right Side	Separation distance (cm)	≤0.5	≤0.5	≤0.5	≤0.5	≤0.5
	exclusion threshold(mW)	11.59	3.42	9.15	2.55	2.75
	Testing required?	YES	YES	YES	YES	NO
Top Side	Separation distance (cm)	7.5	7.5	7.5	7.5	3.5
	exclusion threshold(mW)	401.59	502.28	5170.64	464.69	111.31
	Testing required?	NO	NO	NO	NO	NO
Bottom Side	Separation distance (cm)	≤0.5	≤0.5	≤0.5	≤0.5	4.2
	exclusion threshold(mW)	11.59	3.42	9.15	2.55	157.43
	Testing required?	YES	YES	YES	YES	NO

**Note:**

1. maximum power is the source-based time-average power and represents the maximum RF output power among production units.
2. Per KDB 447498 D04, for larger devices, the test separation distance of adjacent edge configuration is determined by the closest separation between the antenna and the user.
3. Per KDB 447498 D04, if the maximum time-averaged power available does not exceed 1 mW. This stand-alone SAR exemption test.



4. Per KDB 447498 D04, the available maximum time-averaged power or effective radiated power (ERP), whichever is greater, is less than or equal to the threshold  $P_{th}$  (mW) described in the following formula. This method shall only be used at separation distances (cm) from 0.5 centimeters to 40 centimeters and at frequencies from 0.3 GHz to 6 GHz (inclusive).  $P_{th}$  is given by:

$$P_{th} \text{ (mW)} = \begin{cases} ERP_{20 \text{ cm}} (d/20 \text{ cm})^x & d \leq 20 \text{ cm} \\ ERP_{20 \text{ cm}} & 20 \text{ cm} < d \leq 40 \text{ cm} \end{cases}$$

Where

$$x = -\log_{10} \left( \frac{60}{ERP_{20 \text{ cm}} \sqrt{f}} \right) \text{ and } f \text{ is in GHz;}$$

and

$$ERP_{20 \text{ cm}} \text{ (mW)} = \begin{cases} 2040f & 0.3 \text{ GHz} \leq f < 1.5 \text{ GHz} \\ 3060 & 1.5 \text{ GHz} \leq f \leq 6 \text{ GHz} \end{cases}$$

$d$  = the separation distance (cm);

5. Per KDB 447498 D04, An alternative to the SAR-based exemption is using below table and the minimum separation distance (R in meters) from the body of a nearby person for the frequency (f in MHz) at which the source operates, the ERP (watts) is no more than the calculated value prescribed for that frequency. For the exemption in below table to apply, R must be at least  $\lambda/2\pi$ , where  $\lambda$  is the free-space operating wavelength in meters. If the ERP of a single RF source is not easily obtained, then the available maximum time-averaged power may be used in lieu of ERP if the physical dimensions of the radiating structure(s) do not exceed the electrical length of  $\lambda/4$  or if the antenna gain is less than that of a half-wave dipole (1.64 linear value).

RF Source frequency (MHz)	Threshold ERP(watts)
0.3-1.34	1,920 R <sup>2</sup> .
1.34-30	3,450 R <sup>2</sup> /f <sup>2</sup> .
30-300	3.83 R <sup>2</sup> .
300-1,500	0.0128 R <sup>2</sup> f.
1,500-100,000	19.2R <sup>2</sup> .



6. Per KDB 248227 D01, choose the highest output power channel to test SAR and determine further SAR exclusion 8. for each frequency band, testing at higher data rates and higher order modulations is not required when the maximum average output power for each of each of these configurations is less than 1/4db higher than those measured at the lower data rate than 11b mode, thus the SAR can be excluded.
7. Per KDB 616217 D04, SAR evaluation for the front surface of tablet display screens are generally not necessary.



## 8. EUT Test Position

This EUT was tested in Back Side, Front Side, Left Side, Right Side and Bottom Side.

### 8.1 Body-worn Position Conditions

Body-worn Position Conditions:

Body-worn accessory exposure is typically related to voice mode operations when handsets are carried in body-worn accessories. The body-worn accessory procedures in KDB Publication 447498 D01 should be used to test for body-worn accessory SAR compliance, without a headset connected to it. When the same wireless transmission configuration is used for testing body-worn accessory and hotspot mode SAR, respectively, in voice and data mode, SAR results for the most conservative *test separation distance* configuration may be used to support both SAR conditions. When the *reported SAR* for a body-worn accessory, measured without a headset connected to the handset, is  $> 1.2 \text{ W/kg}$ , the highest *reported SAR* configuration for that wireless mode and frequency band should be repeated for the body-worn accessory with a headset attached to the handset.

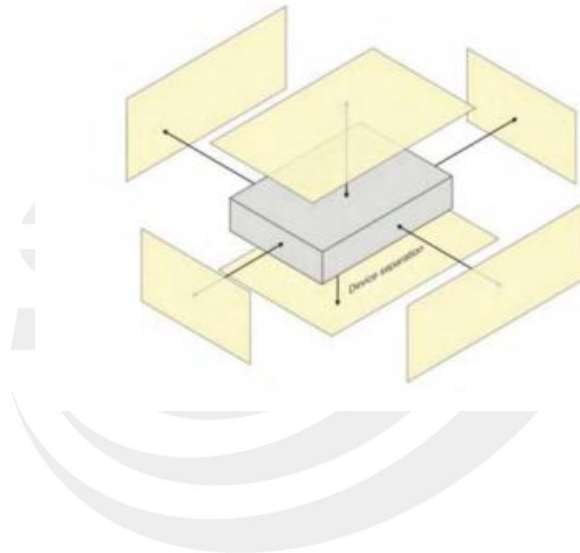





## 9. Uncertainty

### 9.1 Measurement Uncertainty

The following measurement uncertainty levels have been estimated for tests performed on the EUT as specified in IEEE 1528: 2013. This uncertainty represents an expanded uncertainty expressed at approximately the 95% confidence level using a coverage factor of k=2.

Uncertainty Component	Tol (+-%)	Prob. Dist.	Div.	Ci (1g)	Ci (10g)	1g Ui (+-%)	10g Ui (+-%)	vi
<b>Measurement System</b>								
Probe calibration	5.86	N	1	1	1	5.86	5.86	∞
Axial Isotropy	0.16	R	$\sqrt{3}$	$\sqrt{0.5}$	$\sqrt{0.5}$	0.07	0.07	∞
Hemispherical Isotropy	1.06	R	$\sqrt{3}$	$\sqrt{0.5}$	$\sqrt{0.5}$	0.43	0.43	∞
Boundary effect	1	R	$\sqrt{3}$	1	1	0.58	0.58	∞
Linearity	1.27	R	$\sqrt{3}$	1	1	0.73	0.73	∞
System detection limits	1.23	R	$\sqrt{3}$	1	1	0.71	0.71	∞
Modulation response	3.6	R	$\sqrt{3}$	1	1	3.60	3.60	∞
Readout Electronics	0.28	N	1	1	1	0.28	0.28	∞
Response Time	0.19	R	$\sqrt{3}$	1	1	0.11	0.11	∞
Integration Time	1.47	R	$\sqrt{3}$	1	1	0.85	0.85	∞
RF ambient conditions-Noise	3.5	R	$\sqrt{3}$	1	1	2.02	2.02	∞
RF ambient conditions-reflections	3.2	R	$\sqrt{3}$	1	1	1.85	1.85	∞
Probe positioner mechanical tolerance	1.4	R	$\sqrt{3}$	1	1	0.81	0.81	∞
Probe positioning with respect to phantom shell	1.4	R	$\sqrt{3}$	1	1	0.81	0.81	∞
Post-processing	2.3	R	$\sqrt{3}$	1	1	1.33	1.33	∞
<b>Test sample Related</b>								
Test sample positioning	3.1	N	1	1	1	3.10	3.10	∞
Device holder uncertainty	3.8	N	1	1	1	3.80	3.80	∞
SAR drift measurement	4.8	R	$\sqrt{3}$	1	1	2.77	2.77	∞
SAR scaling	2	R	$\sqrt{3}$	1	1	1.15	1.15	∞
<b>Phantom and tissue parameters</b>								
Phantom uncertainty (shape and thickness uncertainty)	4	R	$\sqrt{3}$	1	1	2.31	2.31	∞
Uncertainty in SAR correction for deviations in permittivity and conductivity	2	N	1	1	0.84	2.00	1.68	∞
Liquid conductivity (temperature uncertainty)	2.5	R	$\sqrt{3}$	0.78	0.71	1.95	1.78	∞
Liquid conductivity (measured)	4	N	1	0.78	0.71	0.92	1.04	M
Liquid permittivity (temperature uncertainty)	2.5	R	$\sqrt{3}$	0.23	0.26	1.95	1.78	∞
Liquid permittivity (measured)	5	N	1	0.23	0.26	1.15	1.30	M
Combined Standard Uncertainty		RSS				10.60	10.51	
Expanded Uncertainty (95% Confidence interval)		K=2				21.21	21.03	





## 10. Conducted Power Measurement

### 10.1 Test Result

Burst Average Power (dBm)						
Band	GSM 850			PCS 1900		
Channel	128	190	251	512	661	810
Frequency (MHz)	824.2	836.6	848.8	1850.2	1880.0	1909.8
GPRS (GMSK, 1-Slot)	32.73	32.78	32.86	29.30	29.09	29.13
GPRS (GMSK, 2-Slot)	30.87	30.66	30.77	27.14	26.88	26.64
GPRS (GMSK, 3-Slot)	28.87	28.70	28.79	25.72	25.44	25.15
GPRS (GMSK, 4-Slot)	26.78	26.61	26.69	23.61	23.35	23.05
EGPRS(8PSK, 1-Slot)	26.11	25.69	25.76	25.50	25.96	24.97
EGPRS(8PSK, 2-Slot)	24.91	25.69	25.76	23.45	24.27	23.13
EGPRS(8PSK, 3-Slot)	22.07	22.37	22.37	21.16	21.75	20.54
EGPRS(8PSK, 4-Slot)	20.46	20.15	20.09	18.03	19.00	17.79

Remark: GPRS, CS4 coding scheme. EGPRS, MCS5 coding scheme.  
 Multi-Slot Class 8, Support Max 4 downlink, 1 uplink, 5 working link  
 Multi-Slot Class 10, Support Max 4 downlink, 2 uplink, 5 working link  
 Multi-Slot Class 12, Support Max 4 downlink, 4 uplink, 5 working link

Frame- Average Power(dBm)						
Band	GSM 850			PCS 1900		
Channel	128	190	251	512	661	810
Frequency (MHz)	824.2	836.6	848.8	1850.2	1880.0	1909.8
GPRS (GMSK, 1-Slot)	23.44	23.61	23.50	23.41	23.50	23.64
GPRS (GMSK, 2-Slot)	26.02	26.20	26.02	26.01	26.03	26.23
GPRS (GMSK, 3-Slot)	27.37	27.46	27.36	27.31	27.38	27.53
GPRS (GMSK, 4-Slot)	28.20	28.23	28.13	28.11	28.22	28.35
EGPRS(8PSK, 1-Slot)	23.32	23.47	23.39	23.42	23.51	23.58
EGPRS(8PSK, 2-Slot)	25.60	25.76	25.63	25.70	25.79	25.82
EGPRS(8PSK, 3-Slot)	26.64	26.74	26.65	26.69	26.83	26.88
EGPRS(8PSK, 4-Slot)	27.14	27.20	27.13	27.17	27.31	27.38

Remark :

- SAR testing was performed on the maximum frame-averaged power mode.
- The frame-averaged power is linearly proportion to the slot number configured and it is linearly scaled the maximum

Burst - averaged power based on time slots. The calculated method is shown as below:  
 Frame-averaged power = Burst averaged power (1 TX Slot) – 9.03 dB  
 Frame-averaged power = Burst averaged power (2 TX Slots) – 6.02 dB  
 Frame-averaged power = Burst averaged power (3 TX Slots) - 4.26 dB  
 Frame-averaged power = Burst averaged power (4 TX Slots) – 3.01 dB



**WCDMA**

Band	WCDMA Band 2			WCDMA Band 5		
Channel	9262	9400	9538	4132	4183	4233
Frequency (MHz)	1852.4	1880	1907.6	826.4	836.6	846.6
RMC 12.2Kbps	20.37	20.23	20.20	22.71	22.82	22.74
HSDPA Subtest-1	20.17	19.99	19.42	22.53	22.13	21.59
HSDPA Subtest-2	19.28	19.85	19.59	21.77	22.50	22.35
HSDPA Subtest-3	19.62	19.21	20.27	21.99	21.59	22.30
HSDPA Subtest-4	20.15	19.66	19.81	22.14	21.58	21.82
HSUPA Subtest-1	19.90	20.02	19.83	22.28	22.36	22.09
HSUPA Subtest-2	20.09	19.84	19.52	22.27	22.22	22.52
HSUPA Subtest-3	19.78	19.45	19.80	22.47	22.10	22.40
HSUPA Subtest-4	19.46	20.16	20.28	22.46	22.24	22.27
HSUPA Subtest-5	19.86	20.29	20.23	22.09	22.26	22.03

According to 3GPP 25.101 sub-clause 6.2.2, the maximum output power is allowed to be reduced by following the table.

Table 6.1A: UE maximum output power with HS-DPCCH and E-DCH

UE Transmit Channel Configuration	CM(db)	MPR(db)
For all combinations of ,DPDCH,DPCCH HS-DPDCH,E-DPDCH and E-DPCCH	$0 \leq CM \leq 3.5$	$MAX(CM-1,0)$
Note: CM=1 for $\beta_c/\beta_d=12/15$ , $\beta_{hs}/\beta_c=24/15$ . For all other combinations of DPDCH, DPCCH, HS-DPCCH, E-DPDCH and E-DPCCH the MPR is based on the relative CM difference.		

The device supports MPR to solve linearity issues (ACLR or SEM) due to the higher peak-to average ratios (PAR) of the HSUPA signal. This prevents saturating the full range of the TX DAC inside of device and provides a reduced power output to the RF transceiver chip according to the Cubic Metric (a function of the combinations of DPDCH, DPCCH, HS-DPCCH, E-DPDCH and E-DPCCH).

When E-DPDCH channels are present the beta gains on those channels are reduced firsts to try to get the power under the allowed limit. If the beta gains are lowered as far as possible, then a hard limiting is applied at the maximum allowed level.

The SW currently recalculates the cubic metric every time the beta gains on the E-DPDCH are reduced. The cubic metric will likely get lower each time this is done .However, there is no reported reduction of maximum output power in the HSUPA mode since the device also provides a compensation for the power back-off by increasing the gain of TX\_AGC in the transceiver (PA) device.

The end effect is that the DUT output power is identical to the case where there is no MPR in the device.

**BLE**

BLE				
Mode	Channel Number	Frequency (MHz)	Average Power (dBm)	Output Power (mW)
GFSK(1Mbps)	0	2402	-3.12	0.49
	19	2440	-2.45	0.57
	39	2480	-2.50	0.56





## LTE Conducted Power

### General Note:

1. Anritsu CMW500 base station simulator was used to setup the connection with EUT; the frequency band, channel bandwidth, RB allocation configuration, modulation type are set in the base station simulator to configure EUT transmitting at maximum power and at different configurations which are requested to be reported to FCC, for conducted power measurement and SAR testing.
2. Per KDB 941225 D05, when a properly configured base station simulator is used for the SAR and power measurements, spectrum plots for each RB allocation and offset configuration is not required.
3. Per KDB 941225 D05, start with the largest channel bandwidth and measure SAR for QPSK with 1 RB allocation, using the RB offset and required test channel combination with the highest maximum output power for RB offsets at the upper edge, middle and lower edge of each required test channel.
4. Per KDB 941225 D05, 50% RB allocation for QPSK SAR testing follows 1RB QPSK allocation procedure.
5. Per KDB 941225 D05, For QPSK with 100% RB allocation, SAR is not required when the highest maximum output power for 100 % RB allocation is less than the highest maximum output power in 50% and 1 RB allocations and the highest reported SAR for 1 RB and 50% RB allocation are  $\leq 0.8$  W/kg. Otherwise, SAR is measured for the highest output power channel; and if the reported SAR is  $> 1.45$  W/kg, the remaining required test channels must also be tested.
6. Per KDB 941225 D05, 16QAM output power for each RB allocation configuration is  $>$  not  $\frac{1}{2}$  dB higher than the same configuration in QPSK and the reported SAR for the QPSK configuration is  $\leq 1.45$  W/kg; Per KDB 941225 D05, 16QAM SAR testing is not required.
7. Per KDB 941225 D05, Smaller bandwidth output power for each RB allocation configuration is  $>$  not  $\frac{1}{2}$  dB higher than the same configuration in the largest supported bandwidth, and the reported SAR for the largest supported bandwidth is  $\leq 1.45$  W/kg; Per KDB 941225 D05, smaller bandwidth SAR testing is not required.



LTE Band 2

LTE Band 2 Maximum Average Power [dBm]						
BW [MHz]	RB Size	RB Offset	Mod	Lowest	Middle	Highest
1.4	1	0	QPSK	22.84	22.67	22.55
1.4	1	2		22.87	22.64	22.61
1.4	1	5		22.88	22.58	22.58
1.4	3	0		22.69	22.62	22.43
1.4	3	1		22.68	22.68	22.45
1.4	3	2		22.70	22.65	22.48
1.4	6	0		21.76	21.52	21.57
1.4	1	0		16-QAM	22.75	21.72
1.4	1	2	22.75		21.69	21.96
1.4	1	5	22.71		21.67	21.99
1.4	3	0	21.94		21.66	22.10
1.4	3	1	21.93		21.72	22.05
1.4	3	2	21.96		21.71	22.02
1.4	6	0	21.17		20.65	20.80
3	1	0	QPSK		22.67	22.65
3	1	7		22.68	22.64	22.54
3	1	14		22.63	22.64	22.55
3	8	0		21.72	21.61	21.57
3	8	4		21.66	21.55	21.56
3	8	7		21.79	21.59	21.58
3	15	0		21.64	21.60	21.59
3	1	0		16-QAM	22.74	21.70
3	1	7	22.73		21.67	22.00
3	1	14	22.71		21.75	21.96
3	8	0	21.06		20.74	21.05
3	8	4	21.12		20.84	20.62
3	8	7	20.68		20.76	20.63
3	15	0	21.25		20.64	20.64



LTE BAND 2

LTE Band 2 Maximum Average Power [dBm]						
BW [MHz]	RB Size	RB Offset	Mod	Lowest	Middle	Highest
5	1	0	QPSK	22.53	22.69	22.51
5	1	12		22.56	22.66	22.46
5	1	24		22.59	22.69	22.40
5	12	0		21.74	21.57	21.59
5	12	6		21.67	21.56	21.48
5	12	11		21.72	21.58	21.48
5	25	0		21.70	21.62	21.49
5	1	0	16-QAM	22.16	21.45	21.58
5	1	12		22.12	21.42	21.58
5	1	24		22.14	21.45	21.57
5	12	0		21.06	20.56	21.04
5	12	6		20.64	20.51	21.05
5	12	11		20.65	20.51	20.60
5	25	0		20.69	20.65	21.03
10	1	0	QPSK	22.67	22.56	22.69
10	1	24		22.69	22.52	22.68
10	1	49		22.68	22.54	22.65
10	25	0		21.72	21.61	21.64
10	25	12		21.82	21.54	21.57
10	25	24		21.77	21.60	21.51
10	50	0		21.81	21.58	21.67
10	1	0	16-QAM	22.79	21.70	21.75
10	1	24		22.83	21.68	21.74
10	1	49		22.72	21.72	21.71
10	25	0		20.59	20.63	20.69
10	25	12		20.65	20.68	20.60
10	25	24		20.75	20.67	21.00
10	50	0		20.79	20.69	20.58



LTE BAND 2

LTE Band 2 Maximum Average Power [dBm]						
BW [MHz]	RB Size	RB Offset	Mod	Lowest	Middle	Highest
15	1	0	QPSK	22.74	22.58	22.73
15	1	37		22.64	22.50	22.70
15	1	74		22.62	22.50	22.58
15	36	0		21.72	21.64	21.69
15	36	18		21.73	21.53	21.66
15	36	39		21.70	21.55	21.59
15	75	0		21.77	21.58	21.56
15	1	0	16-QAM	22.78	21.74	22.37
15	1	38		22.75	21.63	22.31
15	1	75		22.74	21.62	22.25
15	36	0		20.82	20.75	20.78
15	36	18		20.76	20.74	20.65
15	36	39		20.71	20.82	21.09
15	75	0		20.76	20.70	20.66
20	1	0	QPSK	22.81	22.73	22.69
20	1	49		22.87	22.58	22.80
20	1	99		22.92	22.64	22.65
20	50	0		21.83	21.65	21.69
20	50	24		21.72	21.61	21.66
20	50	49		21.72	21.65	21.55
20	100	0		21.71	21.60	21.70
20	1	0	16-QAM	21.55	21.53	21.59
20	1	49		21.62	21.34	21.59
20	1	99		21.65	21.40	21.51
20	50	0		20.92	20.63	20.65
20	50	24		20.86	20.61	20.69
20	50	49		20.78	20.68	20.59
20	100	0		20.78	20.61	20.72



LTE BAND 4

LTE Band 4 Maximum Average Power [dBm]						
BW [MHz]	RB Size	RB Offset	Mod	Lowest	Middle	Highest
1.4	1	0	QPSK	22.91	22.78	23.01
1.4	1	2		22.93	22.78	22.91
1.4	1	5		22.96	22.78	22.92
1.4	3	0		22.76	22.80	22.94
1.4	3	1		22.78	22.88	22.75
1.4	3	2		22.81	22.86	22.77
1.4	6	0		21.79	21.81	21.79
1.4	1	0	16-QAM	22.82	22.45	22.28
1.4	1	2		22.87	22.48	22.24
1.4	1	5		22.78	22.50	22.34
1.4	3	0		21.99	22.01	22.25
1.4	3	1		21.98	21.97	22.15
1.4	3	2		21.97	21.96	22.09
1.4	6	0		20.84	21.17	20.98
3	1	0	QPSK	22.69	22.82	22.99
3	1	7		22.70	22.78	23.00
3	1	14		22.69	22.81	22.88
3	8	0		21.82	21.71	21.84
3	8	4		21.81	21.84	21.86
3	8	7		21.83	21.87	21.80
3	15	0		21.78	21.82	21.83
3	1	0	16-QAM	22.86	22.46	22.15
3	1	7		22.74	22.46	22.42
3	1	14		22.85	22.41	22.27
3	8	0		20.68	21.38	21.21
3	8	4		20.69	21.45	21.23
3	8	7		20.73	21.44	20.92
3	15	0		20.94	21.26	21.18





LTE BAND 4

LTE Band 4 Maximum Average Power [dBm]						
BW [MHz]	RB Size	RB Offset	Mod	Lowest	Middle	Highest
5	1	0	QPSK	22.62	22.85	22.56
5	1	12		22.61	22.82	22.68
5	1	24		22.62	22.83	22.56
5	12	0		21.82	21.74	21.88
5	12	6		21.83	21.83	21.83
5	12	11		21.73	21.84	21.84
5	25	0		21.80	21.85	21.93
5	1	0		16-QAM	22.08	21.47
5	1	12	22.07		21.48	22.09
5	1	24	22.12		21.48	22.08
5	12	0	20.69		21.09	20.82
5	12	6	20.71		21.07	21.13
5	12	11	20.77		21.02	21.14
5	25	0	20.92		21.24	21.18
10	1	0	QPSK		22.71	22.92
10	1	24		22.81	22.87	22.83
10	1	49		22.90	22.88	22.99
10	25	0		21.76	21.83	21.81
10	25	12		21.83	21.87	21.78
10	25	24		21.98	21.79	21.90
10	50	0		21.81	21.90	21.85
10	1	0		16-QAM	22.92	21.96
10	1	24	23.04		21.91	22.09
10	1	49	23.06		21.90	22.07
10	25	0	20.76		21.29	20.85
10	25	12	20.73		21.27	20.96
10	25	24	20.88		20.85	21.19
10	50	0	20.83		21.26	20.90



LTE BAND 4

LTE Band 4 Maximum Average Power [dBm]						
BW [MHz]	RB Size	RB Offset	Mod	Lowest	Middle	Highest
15	1	0	QPSK	22.81	22.90	22.91
15	1	37		22.85	22.88	22.97
15	1	74		22.86	22.83	22.99
15	36	0		21.86	21.86	21.82
15	36	18		21.91	21.81	21.78
15	36	39		21.86	21.86	21.74
15	75	0		21.92	21.84	21.79
15	1	0	16-QAM	22.97	21.98	22.43
15	1	38		23.08	21.91	22.40
15	1	75		23.07	21.85	22.38
15	36	0		20.86	21.02	20.96
15	36	18		20.94	21.34	20.87
15	36	39		20.90	21.01	20.78
15	75	0		21.00	21.23	20.91
20	1	0	QPSK	22.80	22.90	22.97
20	1	49		22.87	22.88	22.95
20	1	99		22.88	22.87	23.11
20	50	0		21.71	21.82	21.78
20	50	24		21.85	21.84	21.85
20	50	49		21.90	21.86	21.82
20	100	0		21.90	21.84	21.88
20	1	0	16-QAM	21.47	21.91	21.88
20	1	49		21.53	21.98	21.91
20	1	99		21.54	21.92	21.95
20	50	0		20.93	20.87	20.83
20	50	24		21.04	21.22	20.87
20	50	49		21.02	20.79	20.86
20	100	0		20.94	21.18	20.92



LTE BAND 5

LTE Band 5 Maximum Average Power [dBm]						
BW [MHz]	RB Size	RB Offset	Mod	Lowest	Middle	Highest
1.4	1	0	QPSK	23.37	23.22	23.32
1.4	1	2		23.41	23.25	23.35
1.4	1	5		23.39	23.25	23.25
1.4	3	0		23.32	23.31	23.17
1.4	3	1		23.28	23.43	23.33
1.4	3	2		23.19	23.38	23.33
1.4	6	0		22.33	22.25	22.30
1.4	1	0	16-QAM	23.24	22.98	23.34
1.4	1	2		23.26	22.95	23.36
1.4	1	5		23.29	22.90	23.29
1.4	3	0		22.54	22.37	22.84
1.4	3	1		22.54	22.35	22.81
1.4	3	2		22.47	22.35	22.82
1.4	6	0		21.38	21.45	21.52
3	1	0	QPSK	23.22	23.21	23.41
3	1	7		23.20	23.24	23.40
3	1	14		23.12	23.31	23.34
3	8	0		22.37	22.31	22.29
3	8	4		22.27	22.28	22.25
3	8	7		22.38	22.24	22.24
3	15	0		22.20	22.28	22.29
3	1	0	16-QAM	23.15	22.93	23.39
3	1	7		23.07	22.86	23.31
3	1	14		23.15	22.92	23.24
3	8	0		21.15	21.74	21.38
3	8	4		21.15	21.70	21.35
3	8	7		21.20	21.74	21.34
3	15	0		21.31	21.65	21.30



LTE BAND 5

LTE Band 5 Maximum Average Power [dBm]						
BW [MHz]	RB Size	RB Offset	Mod	Lowest	Middle	Highest
5	1	0	QPSK	23.14	23.24	23.26
5	1	12		23.14	23.33	23.23
5	1	24		23.11	23.28	23.17
5	12	0		22.30	22.26	22.36
5	12	6		22.31	22.28	22.27
5	12	11		22.20	22.32	22.17
5	25	0		22.31	22.34	22.35
5	1	0	16-QAM	22.44	22.00	22.27
5	1	12		22.48	21.92	22.35
5	1	24		22.39	21.98	22.28
5	12	0		21.17	21.35	21.53
5	12	6		21.31	21.35	21.28
5	12	11		21.16	21.41	21.31
5	25	0		21.39	21.58	21.28
10	1	0	QPSK	23.20	23.41	23.35
10	1	24		23.25	23.55	23.38
10	1	49		23.35	23.49	23.23
10	25	0		22.39	22.33	22.44
10	25	12		22.42	22.30	22.42
10	25	24		22.36	22.35	22.36
10	50	0		22.32	22.25	22.39
10	1	0	16-QAM	23.28	22.32	22.33
10	1	24		23.42	22.29	22.44
10	1	49		23.48	22.41	22.29
10	25	0		21.26	21.51	21.42
10	25	12		21.42	21.54	21.48
10	25	24		21.26	21.55	21.32
10	50	0		21.47	21.62	21.46



LTE BAND 7

LTE Band 7 Maximum Average Power [dBm]						
BW [MHz]	RB Size	RB Offset	Mod	Lowest	Middle	Highest
5	1	0	QPSK	21.81	22.02	22.51
5	1	12		21.96	21.75	22.47
5	1	24		21.82	20.97	22.43
5	12	0		21.39	21.54	21.60
5	12	6		21.45	21.44	21.66
5	12	11		21.42	21.30	21.56
5	25	0		21.35	21.55	21.52
5	1	0		16-QAM	21.51	21.29
5	1	12	21.46		21.27	21.81
5	1	24	21.52		21.07	21.81
5	12	0	20.44		20.50	20.64
5	12	6	20.38		20.62	20.72
5	12	11	20.49		20.47	20.62
5	25	0	20.63		20.65	20.61
10	1	0	QPSK		21.64	22.10
10	1	24		21.90	21.55	22.35
10	1	49		21.96	20.92	22.37
10	25	0		20.98	21.19	21.18
10	25	12		21.17	21.09	21.26
10	25	24		21.13	21.11	21.33
10	50	0		21.03	21.12	21.27
10	1	0		16-QAM	21.55	21.24
10	1	24	22.05		21.20	21.32
10	1	49	22.20		20.95	21.38
10	25	0	20.07		20.26	20.28
10	25	12	20.05		20.22	20.30
10	25	24	20.10		20.25	20.31
10	50	0	20.20		20.29	20.28



LTE BAND 7

LTE Band 7 Maximum Average Power [dBm]						
BW [MHz]	RB Size	RB Offset	Mod	Lowest	Middle	Highest
15	1	0	QPSK	21.68	22.08	22.25
15	1	37		21.91	21.53	22.25
15	1	74		21.98	20.60	22.29
15	36	0		21.09	21.13	21.22
15	36	18		21.03	21.08	21.18
15	36	39		21.20	20.94	21.14
15	75	0		21.08	21.22	21.25
15	1	0		16-QAM	21.66	21.16
15	1	38	22.12		21.14	21.97
15	1	75	22.34		20.64	21.98
15	36	0	20.16		20.40	20.21
15	36	18	20.19		20.28	20.27
15	36	39	20.26		20.25	20.33
15	75	0	20.23		20.30	20.35
20	1	0	QPSK		21.38	22.29
20	1	49		21.95	21.83	22.38
20	1	99		21.96	21.29	22.57
20	50	0		21.00	21.14	21.12
20	50	24		21.06	21.08	21.29
20	50	49		21.13	21.06	21.18
20	100	0		21.08	21.20	21.20
20	1	0		16-QAM	20.65	21.30
20	1	49	20.83		21.49	21.23
20	1	99	20.95		21.12	21.21
20	50	0	20.27		20.28	20.26
20	50	24	20.32		20.20	20.35
20	50	49	20.39		20.18	20.38
20	100	0	20.28		20.21	20.32



LTE BAND 12

LTE Band 12 Maximum Average Power [dBm]						
BW [MHz]	RB Size	RB Offset	Mod	Lowest	Middle	Highest
1.4	1	0	QPSK	23.63	23.35	23.50
1.4	1	2		23.70	23.47	23.62
1.4	1	5		23.65	23.49	23.62
1.4	3	0		23.54	23.60	23.50
1.4	3	1		23.41	23.63	23.56
1.4	3	2		23.53	23.61	23.50
1.4	6	0		22.54	22.54	22.51
1.4	1	0	16-QAM	23.50	23.18	23.44
1.4	1	2		23.59	23.00	23.37
1.4	1	5		23.51	23.05	23.32
1.4	3	0		22.60	22.51	22.94
1.4	3	1		22.60	22.53	22.86
1.4	3	2		22.66	22.52	22.83
1.4	6	0		22.07	21.43	21.67
3	1	0	QPSK	23.49	23.47	23.57
3	1	7		23.58	23.48	23.56
3	1	14		23.46	23.47	23.67
3	8	0		22.58	22.69	22.50
3	8	4		22.48	22.46	22.54
3	8	7		22.71	22.53	22.54
3	15	0		22.39	22.51	22.54
3	1	0	16-QAM	23.37	23.14	23.56
3	1	7		23.42	23.02	23.39
3	1	14		23.38	23.03	23.36
3	8	0		21.68	21.74	21.47
3	8	4		21.75	21.66	21.53
3	8	7		21.31	21.72	21.54
3	15	0		21.84	21.58	21.61



LTE BAND 12

LTE Band 12 Maximum Average Power [dBm]						
BW [MHz]	RB Size	RB Offset	Mod	Lowest	Middle	Highest
5	1	0	QPSK	23.31	23.50	23.52
5	1	12		23.48	23.51	23.38
5	1	24		23.50	23.54	23.39
5	12	0		22.45	22.66	22.42
5	12	6		22.65	22.49	22.46
5	12	11		22.61	22.53	22.46
5	25	0		22.64	22.56	22.52
5	1	0	16-QAM	22.62	22.30	22.53
5	1	12		22.70	22.13	22.49
5	1	24		22.65	22.20	22.46
5	12	0		21.78	21.44	21.56
5	12	6		21.44	21.36	21.47
5	12	11		21.39	21.36	21.46
5	25	0		21.46	21.58	21.48
10	1	0	QPSK	23.45	23.47	23.77
10	1	24		23.56	23.49	23.76
10	1	49		23.55	23.42	23.75
10	25	0		22.65	22.61	22.61
10	25	12		22.59	22.58	22.48
10	25	24		22.63	22.41	22.57
10	50	0		22.66	22.48	22.52
10	1	0	16-QAM	23.55	22.45	22.63
10	1	24		23.61	22.50	22.44
10	1	49		23.47	22.43	22.44
10	25	0		21.42	21.57	21.52
10	25	12		21.42	21.59	21.47
10	25	24		21.46	21.57	21.51
10	50	0		21.48	21.57	21.48





LTE BAND 13

LTE Band 13 Maximum Average Power [dBm]						
BW [MHz]	RB Size	RB Offset	Mod	Lowest	Middle	Highest
5	1	0	QPSK	20.79	20.88	20.81
5	1	12		20.69	20.81	20.81
5	1	24		20.72	20.92	20.82
5	12	0		19.83	19.83	20.14
5	12	6		19.77	19.75	20.11
5	12	11		19.82	20.06	19.80
5	25	0		19.82	19.77	20.10
5	1	0		16-QAM	19.98	19.61
5	1	12	19.98		19.60	20.00
5	1	24	19.92		19.85	19.82
5	12	0	18.69		19.24	19.34
5	12	6	19.32		18.76	19.32
5	12	11	19.25		19.25	19.22
5	25	0	19.50		18.76	19.23
10	1	0	QPSK		/	20.90
10	1	24		/	20.89	/
10	1	49		/	20.97	/
10	25	0		/	19.74	/
10	25	12		/	19.79	/
10	25	24		/	20.07	/
10	50	0		/	19.94	/
10	1	0		16-QAM	/	20.84
10	1	24	/		20.78	/
10	1	49	/		20.76	/
10	25	0	/		19.22	/
10	25	12	/		18.56	/
10	25	24	/		19.18	/
10	50	0	/		18.67	/



LTE BAND 17

LTE Band 17 Maximum Average Power [dBm]						
BW [MHz]	RB Size	RB Offset	Mod	Lowest	Middle	Highest
5	1	0	QPSK	23.63	23.49	23.54
5	1	12		23.62	23.45	23.44
5	1	24		23.62	23.51	23.38
5	12	0		22.62	22.43	22.54
5	12	6		22.70	22.48	22.62
5	12	11		22.44	22.45	22.44
5	25	0		22.54	22.61	22.51
5	1	0		16-QAM	22.56	22.15
5	1	12	22.70		22.22	22.54
5	1	24	22.50		22.18	22.52
5	12	0	21.55		21.34	21.47
5	12	6	21.46		21.40	21.56
5	12	11	21.42		21.55	21.51
5	25	0	21.80		21.58	21.55
10	1	0	QPSK		23.56	23.46
10	1	24		23.52	23.48	23.69
10	1	49		23.44	23.41	23.79
10	25	0		22.76	22.54	22.54
10	25	12		22.46	22.50	22.36
10	25	24		22.41	22.49	22.61
10	50	0		22.52	22.50	22.39
10	1	0		16-QAM	23.58	22.57
10	1	24	23.48		22.56	22.52
10	1	49	23.67		22.56	22.55
10	25	0	21.54		21.57	21.47
10	25	12	21.29		21.59	21.49
10	25	24	21.51		21.62	21.66
10	50	0	21.49		21.65	21.54



LTE BAND 25

LTE Band 25 Maximum Average Power [dBm]						
BW [MHz]	RB Size	RB Offset	Mod	Lowest	Middle	Highest
1.4	1	0	QPSK	22.66	22.69	22.79
1.4	1	2		22.79	22.69	22.90
1.4	1	5		22.68	22.70	22.91
1.4	3	0		22.75	22.80	22.67
1.4	3	1		22.85	22.75	22.78
1.4	3	2		22.76	22.75	22.74
1.4	6	0		21.80	21.72	21.79
1.4	1	0	16-QAM	22.78	21.82	22.03
1.4	1	2		22.86	21.86	22.07
1.4	1	5		22.84	21.80	22.00
1.4	3	0		22.04	21.80	22.07
1.4	3	1		22.07	21.75	22.10
1.4	3	2		22.06	21.79	22.08
1.4	6	0		20.91	20.79	20.92
3	1	0	QPSK	22.79	22.71	22.76
3	1	7		22.80	22.71	22.83
3	1	14		22.78	22.72	22.90
3	8	0		21.85	21.84	21.71
3	8	4		21.91	21.83	21.70
3	8	7		21.93	21.84	21.72
3	15	0		21.88	21.73	21.75
3	1	0	16-QAM	22.84	21.86	22.08
3	1	7		22.83	21.82	21.99
3	1	14		22.79	21.84	22.00
3	8	0		20.83	20.93	20.85
3	8	4		20.78	20.93	20.83
3	8	7		20.81	20.91	20.74
3	15	0		20.91	20.72	20.83



LTE BAND 25

LTE Band 25 Maximum Average Power [dBm]						
BW [MHz]	RB Size	RB Offset	Mod	Lowest	Middle	Highest
5	1	0	QPSK	22.70	22.77	22.63
5	1	12		22.72	22.76	22.62
5	1	24		22.75	22.82	22.68
5	12	0		21.81	21.66	21.78
5	12	6		21.84	21.75	21.70
5	12	11		21.80	21.77	21.68
5	25	0		21.86	21.77	21.76
5	1	0		16-QAM	22.23	21.52
5	1	12	22.19		21.54	21.71
5	1	24	22.22		21.53	21.73
5	12	0	20.73		20.66	20.75
5	12	6	20.80		20.73	20.79
5	12	11	20.81		20.72	20.73
5	25	0	20.90		20.80	20.72
10	1	0	QPSK		22.86	22.60
10	1	24		22.80	22.60	22.73
10	1	49		22.87	22.66	22.85
10	25	0		21.88	21.73	21.82
10	25	12		21.87	21.71	21.68
10	25	24		21.94	21.84	21.69
10	50	0		21.88	21.89	21.75
10	1	0		16-QAM	22.91	21.83
10	1	24	22.89		21.85	21.81
10	1	49	22.83		21.81	21.79
10	25	0	20.86		20.87	21.18
10	25	12	20.81		20.86	21.17
10	25	24	20.79		20.83	20.83
10	50	0	20.81		20.86	21.12



LTE BAND 25

LTE Band 25 Maximum Average Power [dBm]						
BW [MHz]	RB Size	RB Offset	Mod	Lowest	Middle	Highest
15	1	0	QPSK	22.84	22.71	22.82
15	1	37		22.80	22.63	22.72
15	1	74		22.76	22.64	22.84
15	36	0		21.78	21.75	21.74
15	36	18		21.90	21.71	21.78
15	36	39		21.80	21.68	21.72
15	75	0		21.91	21.88	21.77
15	1	0		16-QAM	22.91	21.91
15	1	38	22.88		21.84	22.40
15	1	75	22.83		21.84	22.43
15	36	0	20.89		20.94	21.18
15	36	18	20.90		20.91	21.13
15	36	39	21.28		20.88	20.70
15	75	0	20.88		20.81	21.18
20	1	0	QPSK		22.87	22.85
20	1	49		22.98	22.74	22.84
20	1	99		22.97	22.84	22.87
20	50	0		21.79	21.76	21.80
20	50	24		21.77	21.72	21.74
20	50	49		21.93	21.75	21.61
20	100	0		21.83	21.75	21.74
20	1	0		16-QAM	21.63	21.62
20	1	49	21.68		21.46	21.62
20	1	99	21.72		21.57	21.60
20	50	0	20.98		20.77	20.82
20	50	24	20.92		20.80	21.15
20	50	49	20.97		20.72	21.08
20	100	0	20.82		20.83	21.19



LTE BAND 26 Part22

LTE Band 26 Part22 Maximum Average Power [dBm]						
BW [MHz]	RB Size	RB Offset	Mod	Lowest	Middle	Highest
1.4	1	0	QPSK	23.43	23.24	23.38
1.4	1	2		23.42	23.28	23.41
1.4	1	5		23.42	23.30	23.32
1.4	3	0		23.31	23.31	23.23
1.4	3	1		23.24	23.38	23.32
1.4	3	2		23.26	23.43	23.31
1.4	6	0		22.33	22.31	22.35
1.4	1	0	16-QAM	23.28	22.94	23.42
1.4	1	2		23.35	22.86	23.48
1.4	1	5		23.32	22.89	23.47
1.4	3	0		22.56	22.31	22.90
1.4	3	1		22.55	22.34	22.87
1.4	3	2		22.63	22.38	22.88
1.4	6	0		21.30	21.32	21.56
3	1	0	QPSK	23.20	23.27	23.45
3	1	7		23.20	23.27	23.46
3	1	14		23.23	23.25	23.44
3	8	0		22.31	22.24	22.36
3	8	4		22.38	22.33	22.32
3	8	7		22.29	22.29	22.32
3	15	0		22.30	22.24	22.35
3	1	0	16-QAM	23.15	22.88	23.40
3	1	7		23.13	22.87	23.36
3	1	14		23.05	22.83	23.30
3	8	0		21.19	21.80	21.31
3	8	4		21.13	21.58	21.31
3	8	7		21.48	21.60	21.39
3	15	0		21.32	21.33	21.37



LTE BAND 26 Part22

LTE Band 26 Part22 Maximum Average Power [dBm]						
BW [MHz]	RB Size	RB Offset	Mod	Lowest	Middle	Highest
5	1	0	QPSK	23.10	23.27	23.30
5	1	12		23.05	23.36	23.27
5	1	24		23.18	23.30	23.25
5	12	0		22.34	22.29	22.40
5	12	6		22.32	22.31	22.30
5	12	11		22.26	22.29	22.36
5	25	0		22.27	22.36	22.39
5	1	0	16-QAM	22.49	21.99	22.43
5	1	12		22.40	21.97	22.35
5	1	24		22.52	22.11	22.35
5	12	0		21.22	21.44	21.33
5	12	6		21.51	21.17	21.27
5	12	11		21.54	21.28	21.25
5	25	0		21.62	21.46	21.31
10	1	0	QPSK	23.24	23.28	23.39
10	1	24		23.30	23.42	23.44
10	1	49		23.33	23.43	23.39
10	25	0		22.25	22.37	22.40
10	25	12		22.47	22.22	22.30
10	25	24		22.40	22.38	22.40
10	50	0		22.24	22.29	22.30
10	1	0	16-QAM	23.32	22.29	22.51
10	1	24		23.45	22.34	22.37
10	1	49		23.46	22.49	22.33
10	25	0		21.50	21.65	21.39
10	25	12		21.15	21.44	21.64
10	25	24		21.22	21.70	21.34
10	50	0		21.22	21.48	21.70





## LTE BAND 26 Part22

LTE Band 26 Part22 Maximum Average Power [dBm]						
BW [MHz]	RB Size	RB Offset	Mod	Lowest	Middle	Highest
15	1	0	QPSK	23.23	23.45	23.32
15	1	37		23.22	23.44	23.47
15	1	74		23.38	23.38	23.36
15	36	0		22.24	22.33	22.47
15	36	18		22.38	22.32	22.41
15	36	39		22.35	22.40	22.27
15	75	0		22.39	22.30	22.46
15	1	0		16-QAM	23.34	22.32
15	1	38	23.39		22.36	22.99
15	1	75	23.50		22.38	22.91
15	36	0	21.26		21.40	21.59
15	36	18	21.15		21.47	21.40
15	36	39	21.60		21.46	21.34
15	75	0	21.30		21.36	21.35



LTE BAND 26 Part90

LTE Band 26 Part 90 Maximum Average Power [dBm]						
BW [MHz]	RB Size	RB Offset	Mod	Lowest	Middle	Highest
1.4	1	0	QPSK	23.46	23.32	23.45
1.4	1	2		23.47	23.35	23.38
1.4	1	5		23.37	23.33	23.39
1.4	3	0		23.29	23.31	23.30
1.4	3	1		23.32	23.45	23.32
1.4	3	2		23.31	23.25	23.19
1.4	6	0		22.29	22.32	22.27
1.4	1	0	16-QAM	23.34	22.69	22.95
1.4	1	2		23.32	22.73	22.86
1.4	1	5		23.32	22.75	22.90
1.4	3	0		22.44	22.48	22.66
1.4	3	1		22.49	22.40	22.50
1.4	3	2		22.54	22.41	22.56
1.4	6	0		21.37	21.51	21.45
3	1	0	QPSK	23.34	23.32	23.43
3	1	7		23.35	23.37	23.42
3	1	14		23.25	23.32	23.39
3	8	0		22.25	22.38	22.28
3	8	4		22.26	22.35	22.19
3	8	7		22.40	22.21	22.19
3	15	0		22.28	22.26	22.29
3	1	0	16-QAM	23.30	22.76	22.95
3	1	7		23.28	22.62	22.95
3	1	14		23.34	22.68	22.88
3	8	0		21.23	21.77	21.28
3	8	4		21.24	21.84	21.33
3	8	7		21.32	21.61	21.31
3	15	0		21.40	21.63	21.32



LTE BAND 26 Part90

LTE Band 26 Part 90 Maximum Average Power [dBm]						
BW [MHz]	RB Size	RB Offset	Mod	Lowest	Middle	Highest
5	1	0	QPSK	23.31	23.17	23.24
5	1	12		23.23	23.23	23.26
5	1	24		23.32	23.27	23.17
5	12	0		22.25	22.36	22.21
5	12	6		22.35	22.34	22.20
5	12	11		22.31	22.19	22.19
5	25	0		22.38	22.28	22.33
5	1	0	16-QAM	22.62	21.92	22.28
5	1	12		22.66	21.86	22.20
5	1	24		22.53	21.86	22.22
5	12	0		21.20	21.17	21.36
5	12	6		21.14	21.51	21.25
5	12	11		21.15	21.20	21.26
5	25	0		21.33	21.61	21.18
10	1	0	QPSK	N/A	23.26	N/A
10	1	24		N/A	23.14	N/A
10	1	49		N/A	23.50	N/A
10	25	0		N/A	22.37	N/A
10	25	12		N/A	22.36	N/A
10	25	24		N/A	22.26	N/A
10	50	0		N/A	22.34	N/A
10	1	0	16-QAM	N/A	23.29	N/A
10	1	24		N/A	23.25	N/A
10	1	49		N/A	23.18	N/A
10	25	0		N/A	21.20	N/A
10	25	12		N/A	21.45	N/A
10	25	24		N/A	21.23	N/A
10	50	0		N/A	21.54	N/A



LTE BAND 41

LTE Band 41 Maximum Average Power [dBm]						
BW [MHz]	RB Size	RB Offset	Mod	Lowest	Middle	Highest
5	1	0	QPSK	21.70	21.76	21.76
5	1	12		21.72	21.69	21.73
5	1	24		21.75	21.78	21.77
5	12	0		20.79	20.94	20.61
5	12	6		20.88	20.92	20.72
5	12	11		20.87	20.91	20.68
5	25	0		20.71	20.90	20.61
5	1	0		16-QAM	20.46	20.76
5	1	12	20.55		20.74	20.61
5	1	24	20.48		20.71	20.53
5	12	0	19.30		19.51	19.30
5	12	6	19.29		19.49	19.27
5	12	11	19.32		19.59	19.31
5	25	0	19.54		19.46	19.44
10	1	0	QPSK		21.35	21.71
10	1	24		21.32	21.67	21.44
10	1	49		21.42	21.68	21.44
10	25	0		20.40	20.62	20.57
10	25	12		20.34	20.55	20.51
10	25	24		20.46	20.54	20.42
10	50	0		20.33	20.57	20.41
10	1	0		16-QAM	21.18	20.47
10	1	24	21.18		20.35	20.66
10	1	49	21.31		20.26	20.72
10	25	0	19.19		19.28	19.12
10	25	12	19.18		19.12	19.21
10	25	24	19.27		19.20	19.16
10	50	0	18.95		19.26	19.08



LTE BAND 41

LTE Band 41 Maximum Average Power [dBm]						
BW [MHz]	RB Size	RB Offset	Mod	Lowest	Middle	Highest
15	1	0	QPSK	21.33	21.59	21.58
15	1	37		21.36	21.71	21.55
15	1	74		21.57	21.63	21.55
15	36	0		20.29	20.63	20.56
15	36	18		20.54	20.56	20.54
15	36	39		20.54	20.51	20.56
15	75	0		20.39	20.61	20.53
15	1	0	16-QAM	21.17	20.40	20.86
15	1	38		21.19	20.34	20.84
15	1	75		21.37	20.34	20.78
15	36	0		18.92	19.27	19.08
15	36	18		18.95	19.07	19.14
15	36	39		19.12	19.14	19.07
15	75	0		19.25	19.28	19.19
20	1	0	QPSK	21.39	21.79	21.26
20	1	49		21.56	21.73	21.77
20	1	99		21.69	21.73	21.70
20	50	0		20.47	20.64	20.65
20	50	24		20.54	20.52	20.56
20	50	49		20.57	20.67	20.63
20	100	0		20.51	20.69	20.58
20	1	0	16-QAM	20.10	20.39	20.75
20	1	49		20.24	20.17	20.63
20	1	99		20.35	20.21	20.61
20	50	0		19.13	19.22	19.21
20	50	24		19.26	19.08	19.15
20	50	49		19.43	19.09	19.20
20	100	0		19.14	19.17	19.26



## 11. EUT and Test Setup Photo

### 11.1 EUT Photo

Front side

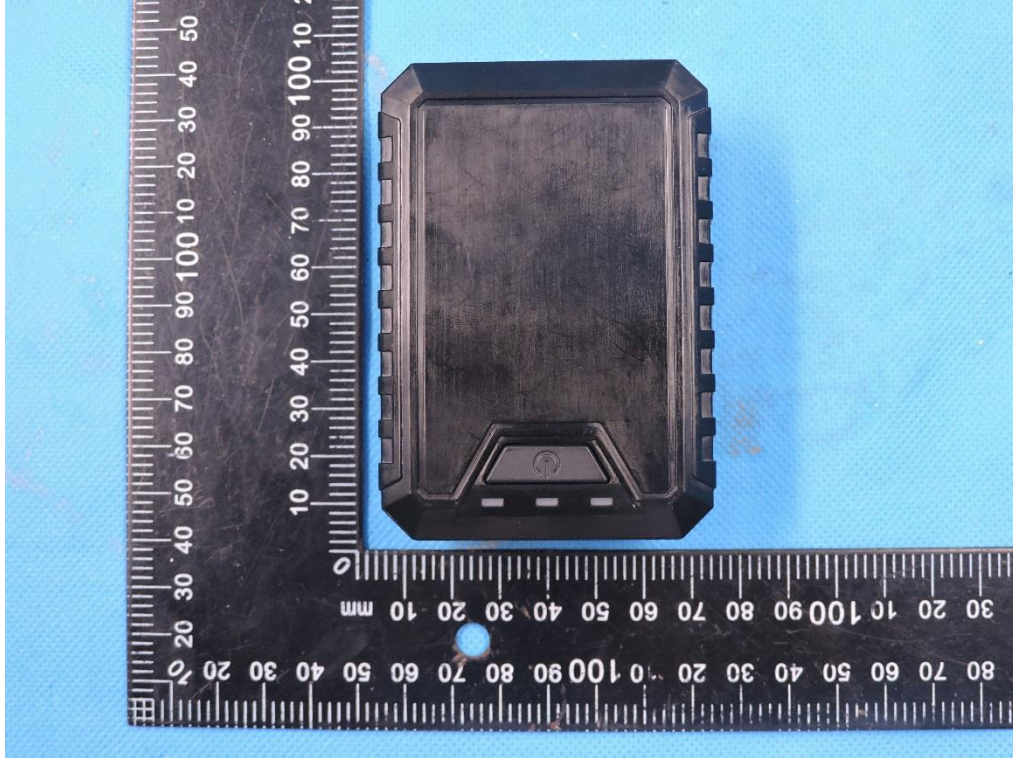

Back side







Top side



Bottom side

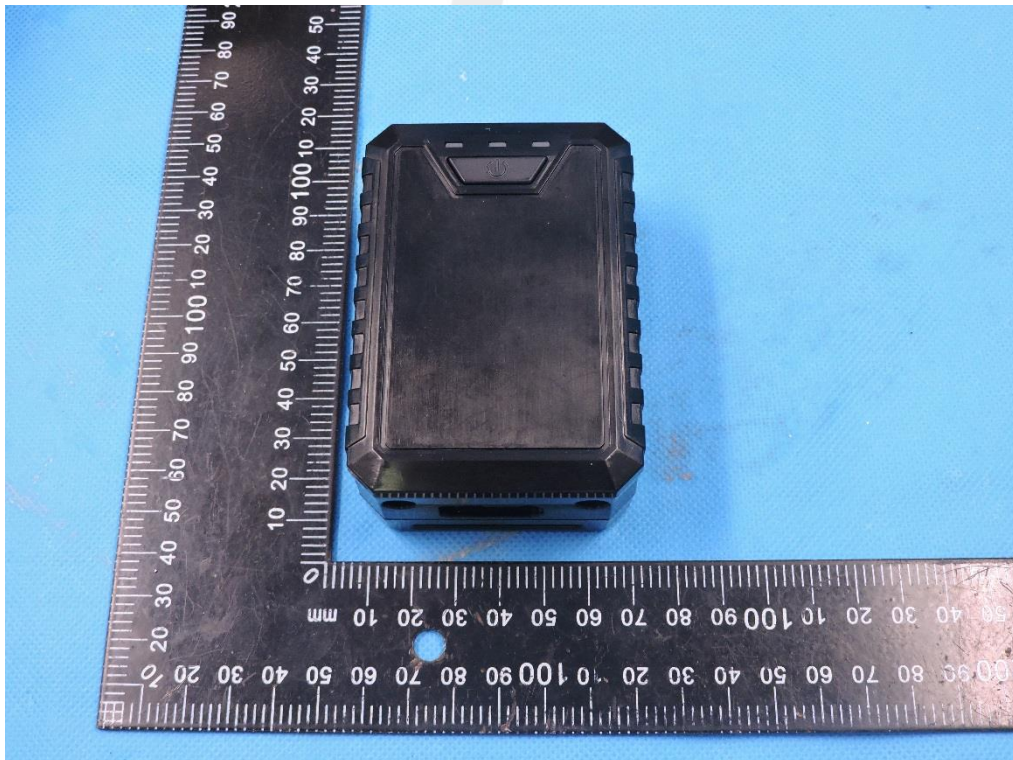



Left side



Right side

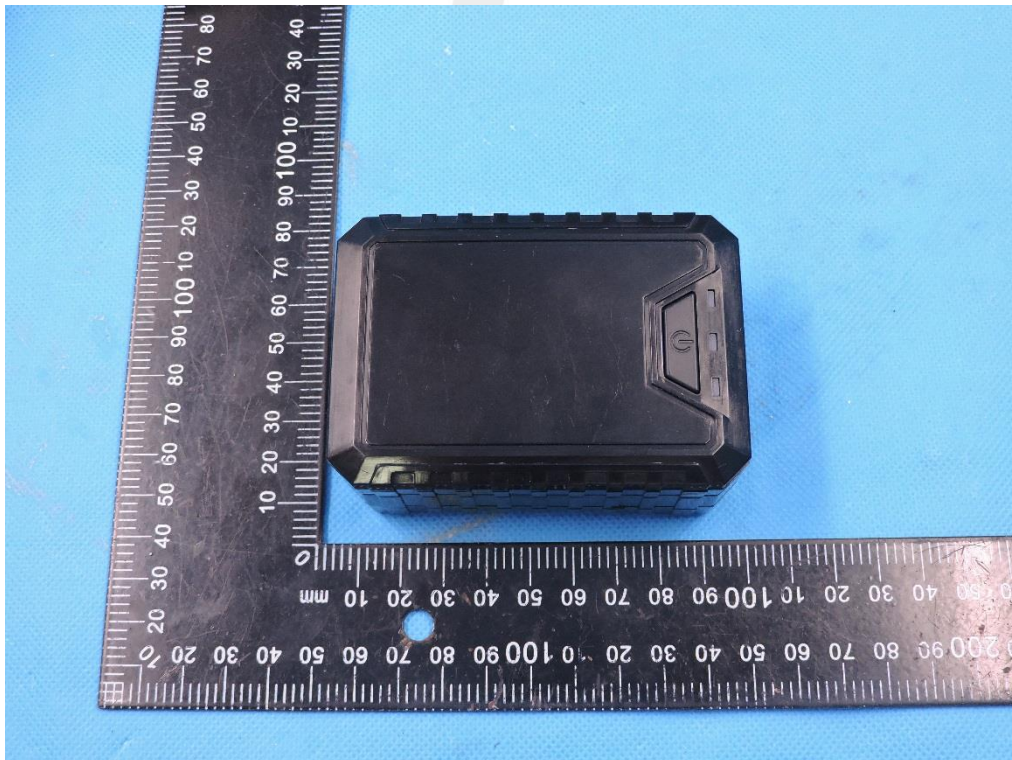

## 11.2 Setup Photo

Body Back side(separation distance is 5mm)

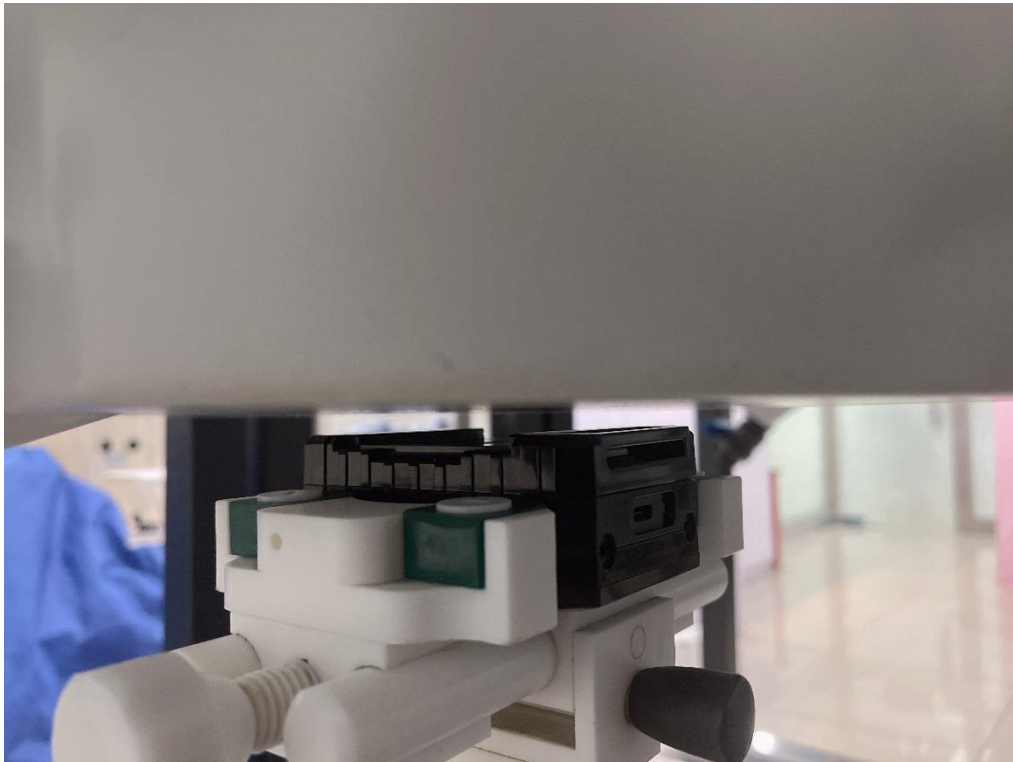

Body Front side (separation distance is 5mm)

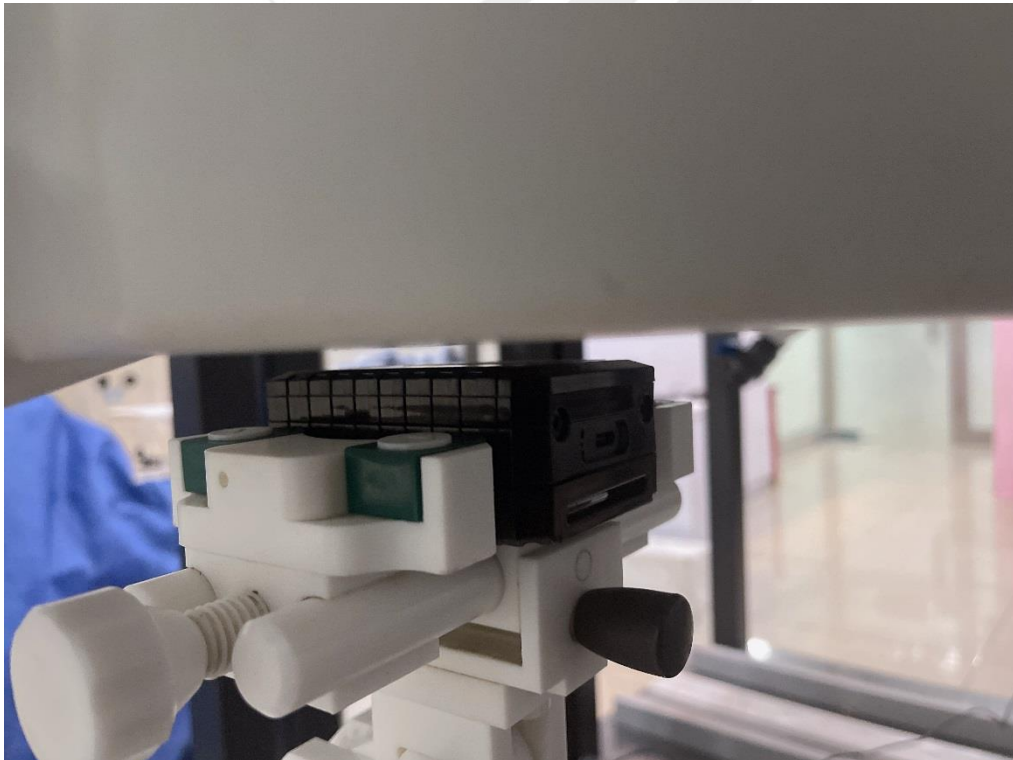



Body Left Side (separation distance is 5mm)

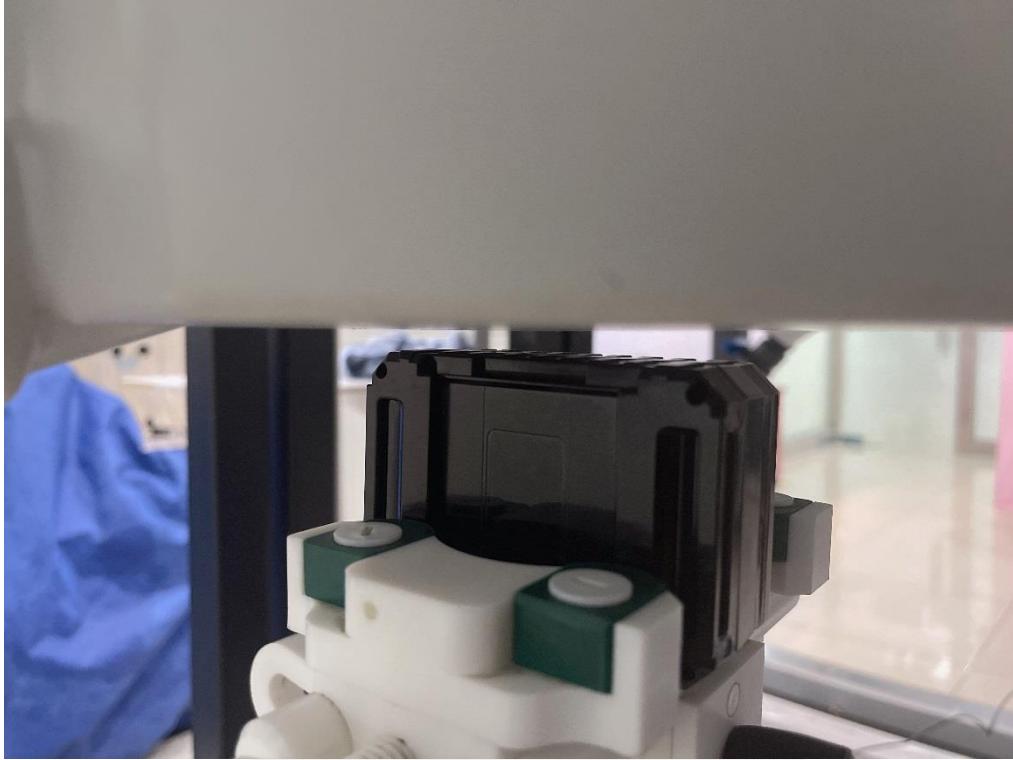

Body Right Side (separation distance is 5mm)

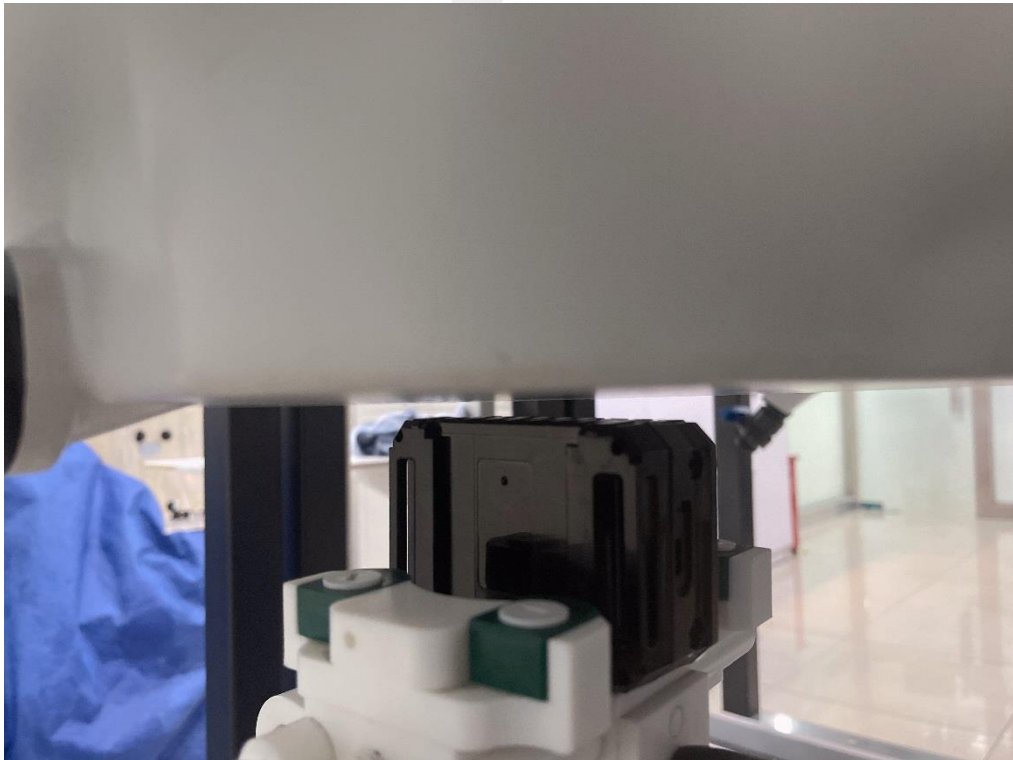

Body Bottom Side (separation distance is 5mm)

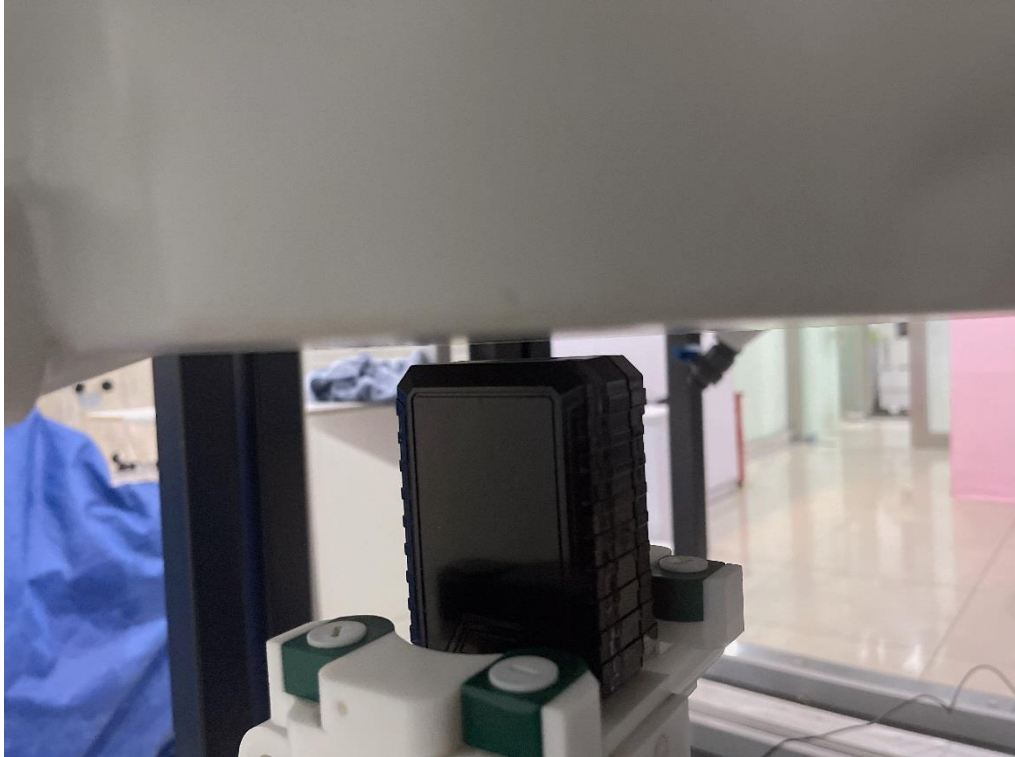

Liquid depth (15 cm)

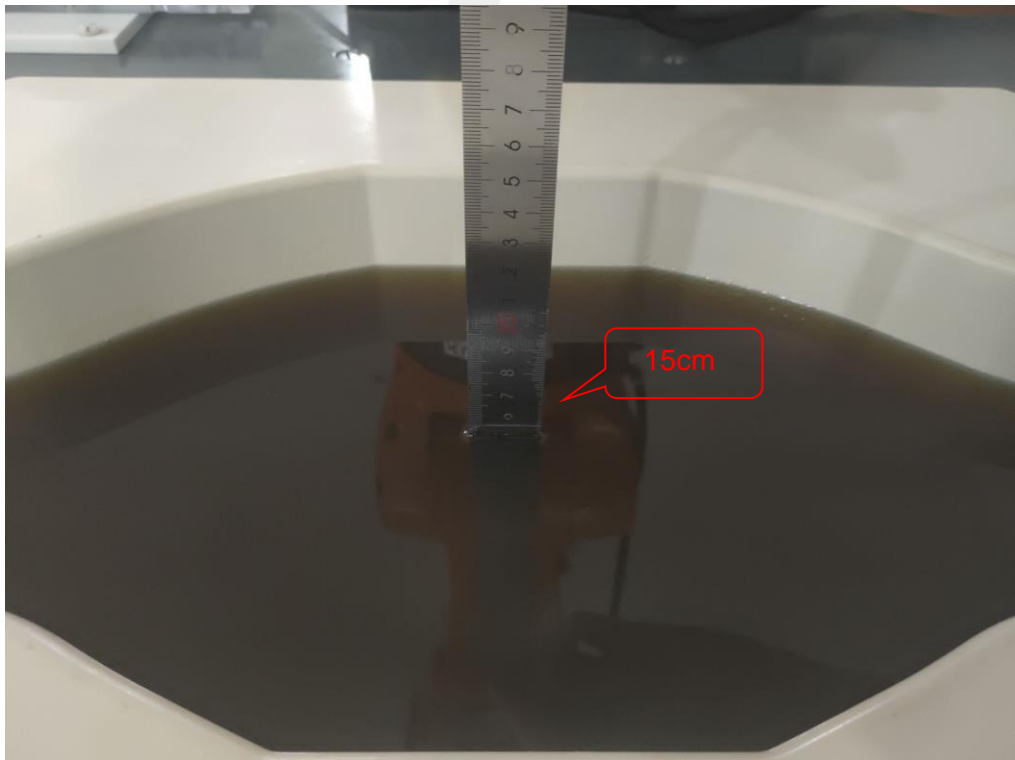



## 12. SAR Result Summary

### 12.1 Body-worn and Hotspot SAR

Band	Model	Test Position	Freq.	SAR (1g) (W/kg)	Power Drift(%)	Max.Turn-up Power(dBm)	Meas.Output Power(dBm)	Scaled SAR (W/Kg)	Meas.No.
GSM850	GPRS Data-2 Slot	Front Side	824.2	0.247	-3.00	31.00	30.87	<b>0.255</b>	<b>1</b>
		Back Side	824.2	0.044	-2.26	31.00	30.87	0.045	/
		Left Side	824.2	0.121	2.40	31.00	30.87	0.125	/
		Right Side	824.2	0.133	3.61	31.00	30.87	0.137	/
		Top Side	824.2	0.025	0.19	31.00	30.87	0.026	/
		Bottom Side	824.2	0.111	-0.80	31.00	30.87	0.114	/
GSM1900	GPRS Data-3 Slot	Front Side	1850.2	1.209	2.81	25.80	25.72	<b>1.231</b>	<b>2</b>
		Front Side	1880	1.121	-0.54	25.80	25.44	1.218	/
		Front Side	1909.8	0.958	-2.22	25.80	25.15	1.113	/
		Back Side	1850.2	0.071	2.39	25.80	25.72	0.072	/
		Left Side	1850.2	0.758	1.91	25.80	25.72	0.772	/
		Right Side	1850.2	0.695	-2.13	25.80	25.72	0.708	/
WCDMA Band II	RMC	Bottom Side	1850.2	0.448	-3.49	25.80	25.72	0.456	/
		Front Side	1852.4	0.575	2.07	20.50	20.37	<b>0.592</b>	<b>3</b>
		Back Side	1852.4	0.079	1.66	20.50	20.37	0.081	/
		Left Side	1852.4	0.226	-3.23	20.50	20.37	0.233	/
		Right Side	1852.4	0.235	-0.29	20.50	20.37	0.242	/
WCDMA Band V	RMC	Bottom Side	1852.4	0.125	-1.15	20.50	20.37	0.129	/
		Front Side	836.6	0.159	0.69	23.00	22.82	<b>0.166</b>	<b>4</b>
		Back Side	836.6	0.054	0.10	23.00	22.82	0.056	/
		Left Side	836.6	0.122	0.80	23.00	22.82	0.127	/
		Right Side	836.6	0.096	-0.91	23.00	22.82	0.100	/
		Bottom Side	836.6	0.085	-3.14	23.00	22.82	0.089	/



Band	BW (MHz)	Mod.	RB Size	RB offset	Test Position	Freq.	Result 1g (W/Kg)	Power Drift(%)	Max. Turn-up Power(dBm)	Meas. Output Power(dBm)	Scaled SAR (W/Kg)	Meas.No.
LTE Band 2	20M	QPSK	1	99	Front side	1860	0.492	2.33	23	22.92	<b>0.501</b>	<b>5</b>
			50	0	Front side	1860	0.456	-2.71	22	21.83	0.474	/
			1	99	Back Side	1860	0.039	0.28	23	22.92	0.040	/
			50	0	Back Side	1860	0.021	-2.90	22	21.83	0.022	/
			1	99	Left Side	1860	0.221	-2.85	23	22.92	0.225	/
			50	0	Left Side	1860	0.236	2.51	22	21.83	0.245	/
			1	99	Right Side	1860	0.158	1.23	23	22.92	0.161	/
			50	0	Right Side	1860	0.147	2.51	22	21.83	0.153	/
			1	99	Bottom Side	1860	0.166	0.39	23	22.92	0.169	/
			50	0	Bottom Side	1860	0.136	-0.49	22	21.83	0.141	/
LTE Band 4	20M	QPSK	1	0	Front side	1732.5	0.432	1.28	23.5	22.9	<b>0.496</b>	<b>6</b>
			50	49	Front side	1720	0.355	1.73	22	21.9	0.363	/
			1	0	Back Side	1732.5	0.069	-1.97	23.5	22.9	0.079	/
			50	49	Back Side	1720	0.062	3.35	22	21.9	0.063	/
			1	0	Left Side	1732.5	0.214	-3.49	23.5	22.9	0.246	/
			50	49	Left Side	1720	0.241	-3.38	22	21.9	0.247	/
			1	0	Right Side	1732.5	0.125	-0.21	23.5	22.9	0.144	/
			50	49	Right Side	1720	0.136	-0.85	22	21.9	0.139	/
			1	0	Bottom Side	1732.5	0.059	-3.99	23.5	22.9	0.068	/
			50	49	Bottom Side	1720	0.059	1.35	22	21.9	0.060	/
LTE Band 5	10M	QPSK	1	24	Front side	836.5	0.178	-3.67	24	23.55	<b>0.197</b>	<b>7</b>
			25	0	Front side	844	0.165	-3.52	22.5	22.44	0.167	/
			1	24	Back Side	836.5	0.052	-2.34	24	23.55	0.058	/
			25	0	Back Side	844	0.036	0.61	22.5	22.44	0.037	/
			1	24	Left Side	836.5	0.120	1.35	24	23.55	0.133	/
			25	0	Left Side	844	0.102	0.75	22.5	22.44	0.103	/
			1	24	Right Side	836.5	0.055	1.69	24	23.55	0.061	/
			25	0	Right Side	844	0.051	2.61	22.5	22.44	0.052	/
			1	24	Bottom Side	836.5	0.009	1.47	24	23.55	0.010	/
			25	0	Bottom Side	844	0.005	-1.63	22.5	22.44	0.005	/



LTE Band 7	10M	QPSK	1	0	Front side	2560	0.823	2.23	23	21.96	1.046	/
			1	0	Front side	2560	0.702	-0.78	23	21.29	1.041	/
			1	0	Front side	2560	0.964	3.81	23	22.57	<b>1.064</b>	<b>8</b>
			50	0	Front side	2560	0.855	-3.03	21.5	21.29	0.897	/
			100	0	Front side	2560	0.898	3.68	21.5	21.2	0.962	/
			1	0	Back Side	2560	0.123	1.84	23	22.57	0.136	/
			50	0	Back Side	2560	0.102	0.63	21.5	21.29	0.107	/
			1	0	Left Side	2560	0.550	-2.12	23	22.57	0.607	/
			50	0	Left Side	2560	0.456	-2.87	21.5	21.29	0.479	/
			1	0	Right Side	2560	0.369	-3.43	23	22.57	0.407	/
			50	0	Right Side	2560	0.358	-1.42	21.5	21.29	0.376	/
			1	0	Bottom Side	2560	0.215	2.56	23	22.57	0.237	/
			50	0	Bottom Side	2560	0.223	-0.76	21.5	21.29	0.234	/
LTE Band 12	10M	QPSK	1	0	Front side	711	0.240	1.53	24	23.77	<b>0.253</b>	<b>9</b>
			25	0	Front side	704	0.212	-2.78	23	22.66	0.229	/
			1	0	Back Side	711	0.054	-1.65	24	23.77	0.057	/
			25	0	Back Side	704	0.041	2.56	23	22.66	0.044	/
			1	0	Left Side	711	0.141	-3.14	24	23.77	0.149	/
			25	0	Left Side	704	0.136	0.48	23	22.66	0.147	/
			1	0	Right Side	711	0.112	0.08	24	23.77	0.118	/
			25	0	Right Side	704	0.121	2.12	23	22.66	0.131	/
			1	0	Bottom Side	711	0.056	-1.43	24	23.77	0.059	/
			25	0	Bottom Side	704	0.045	-2.62	23	22.66	0.049	/
LTE Band 13	10M	QPSK	1	49	Front side	782	0.764	3.22	21	20.97	<b>0.769</b>	<b>10</b>
			25	24	Front side	782	0.658	2.93	21	20.07	0.815	/
			1	49	Back Side	782	0.098	-3.25	21	20.97	0.099	/
			25	24	Back Side	782	0.085	-2.05	21	20.07	0.105	/
			1	49	Left Side	782	0.245	-3.61	21	20.97	0.247	/
			25	24	Left Side	782	0.236	-1.46	21	20.07	0.292	/
			1	49	Right Side	782	0.125	-0.76	21	20.97	0.126	/
			25	24	Right Side	782	0.133	-2.23	21	20.07	0.165	/
			1	49	Bottom Side	782	0.211	3.93	21	20.97	0.212	/
			25	24	Bottom Side	782	0.231	-3.12	21	20.07	0.286	/





LTE Band 17	10M	QPSK	1	49	Front side	711	0.221	-1.13	24	23.79	<b>0.232</b>	<b>11</b>
			25	0	Front side	709	0.215	-2.13	23	22.76	0.227	/
			1	49	Back Side	711	0.102	-1.93	24	23.79	0.107	/
			25	0	Back Side	709	0.100	2.25	23	22.76	0.106	/
			1	49	Left Side	711	0.123	-0.76	24	23.79	0.129	/
			25	0	Left Side	709	0.142	-0.63	23	22.76	0.150	/
			1	49	Right Side	711	0.132	0.85	24	23.79	0.139	/
			25	0	Right Side	709	0.124	2.91	23	22.76	0.131	/
			1	49	Bottom Side	711	0.165	-1.92	24	23.79	0.173	/
			25	0	Bottom Side	709	0.133	-3.62	23	22.76	0.141	/
LTE Band 25	20M	QPSK	1	49	Front side	1860	0.513	-3.37	23	22.98	<b>0.515</b>	<b>12</b>
			50	49	Front side	1860	0.488	-0.77	22	21.93	0.496	/
			1	49	Back Side	1860	0.024	-2.81	23	22.98	0.024	/
			50	49	Back Side	1860	0.059	-1.70	22	21.93	0.060	/
			1	49	Left Side	1860	0.236	-1.52	23	22.98	0.237	/
			50	49	Left Side	1860	0.244	2.93	22	21.93	0.248	/
			1	49	Right Side	1860	0.211	-1.63	23	22.98	0.212	/
			50	49	Right Side	1860	0.127	-1.03	22	21.93	0.129	/
			1	49	Bottom Side	1860	0.026	-2.17	23	22.98	0.026	/
			50	49	Bottom Side	1860	0.021	-0.83	22	21.93	0.021	/
LTE Band 26	15M	QPSK	1	37	Front side	841.5	0.220	-1.21	24	23.47	<b>0.249</b>	<b>13</b>
			36	0	Front side	841.5	0.215	-1.52	22.5	22.47	0.216	/
			1	37	Back Side	841.5	0.045	0.93	24	23.47	0.051	/
			36	0	Back Side	841.5	0.041	0.62	22.5	22.47	0.041	/
			1	37	Left Side	841.5	0.141	-1.98	24	23.47	0.159	/
			36	0	Left Side	841.5	0.136	1.12	22.5	22.47	0.137	/
			1	37	Right Side	841.5	0.125	2.40	24	23.47	0.141	/
			36	0	Right Side	841.5	0.142	-1.32	22.5	22.47	0.143	/
			1	37	Bottom Side	841.5	0.133	-2.86	24	23.47	0.150	/
			36	0	Bottom Side	841.5	0.142	-0.20	22.5	22.47	0.143	/



LTE Band 41	20M	QPSK	1	0	Front side	2605	0.297	-0.14	22	21.79	<b>0.312</b>	<b>14</b>
			50	49	Front side	2605	0.254	2.91	21	20.67	0.274	/
			1	0	Back Side	2605	0.069	1.07	22	21.79	0.072	/
			50	49	Back Side	2605	0.049	-3.70	21	20.67	0.053	/
			1	0	Left Side	2605	0.158	0.03	22	21.79	0.166	/
			50	49	Left Side	2605	0.147	-2.26	21	20.67	0.159	/
			1	0	Right Side	2605	0.136	-3.62	22	21.79	0.143	/
			50	49	Right Side	2605	0.142	0.74	21	20.67	0.153	/
			1	0	Bottom Side	2605	0.125	-0.27	22	21.79	0.131	/
			50	49	Bottom Side	2605	0.112	-0.96	21	20.67	0.121	/

## Note:

1. The test separation of all above table is 5mm.
2. Per KDB 447498 D04, the reported SAR is the measured SAR value adjusted for maximum tune-up tolerance.
  - a. Tune-up scaling Factor = tune-up limit power (mW) / EUT RF power (mW), where tune-up limit is the maximum rated power among all production units.
  - b. Scaled SAR(W/kg)= Measured SAR(W/kg)\*Tune-up Scaling Factor



**Repeated SAR**

Band	Mode	Test Position	Freq.	Result 1g (W/Kg)	Power Drift(%)	Max.Turn-up Power(dBm)	Meas.Output Power(dBm)	Scaled SAR(W/Kg)	Meas. No.
GSM 1900	GPRS	Front Side	1850.2	1.209	-1.66	25.80	25.72	1.231	-
	Data-3	Front Side	1880	1.121	0.60	25.80	25.44	1.218	-
	Slot	Front Side	1909.8	0.958	-3.46	25.80	25.15	1.113	-

Band	BW (MHz)	Mod.	RB Size	RB offset	Test Position	Freq.	Result 1g (W/Kg)	Power Drift(%)	Max.Turn-up Power(dBm)	Meas.Output Power(dBm)	Scaled SAR(W/Kg)	Meas. No.
LTE Band 7	10M	QPSK	1	0	Front side	2560	0.822	3.82	23	21.96	1.044	-
			1	0	Front side	2560	0.667	2.96	23	21.29	0.989	-
			1	0	Front side	2560	0.918	2.61	23	22.57	1.014	-
			50	0	Front side	2560	0.835	3.85	21.5	21.29	0.876	-
			100	0	Front side	2560	0.868	1.77	21.5	21.2	0.930	-



**Repeated SAR measurement**

Band	Mode	Test Position	Freq.	Original Measured SAR 1g(W/kg)	1 st Repeated SAR 1g	Ratio	Original Measured SAR 1g(W/kg)	2nd Repeated SAR 1g	Ratio
GSM1900	GPRS	Front Side	1850.2	1.209	1.171	1.032	-	-	-
	Data-3	Front Side	1880	1.121	1.100	1.019	-	-	-
	Slot	Front Side	1909.8	0.958	0.938	1.021	-	-	-

Band	BW (MHz)	Mod.	RB Size	RB offset	Test Position	Freq.	Original Measured SAR 1g(W/kg)	1 st Repeated SAR 1g	Ratio	Original Measured	2nd Repeated SAR 1g	Ratio
LTE Band 7	10M	QPSK	1	0	Front side	2560	0.823	0.822	1.001	-	-	-
			1	0	Front side	2560	0.702	0.667	1.052	-	-	-
			1	0	Front side	2560	0.964	0.918	1.050	-	-	-
			50	0	Front side	2560	0.855	0.835	1.024	-	-	-
			100	0	Front side	2560	0.898	0.868	1.035	-	-	-

Note:

1. Per KDB 865664 D01, for each frequency band, repeated SAR measurement is required only when the measured SAR is  $\geq 0.8W/Kg$ .
2. Per KDB 865664 D01, if the ratio of largest to smallest SAR for the original and first repeated measurement is  $\leq 1.2$  and the measured SAR  $< 1.45W/Kg$ , only one repeated measurement is required.
3. Perform a second repeated measurement only if the ratio of largest to smallest SAR for the original and first repeated measurements is  $> 1.20$  or when the original or repeated measurement is  $\geq 1.45W/Kg$ .
4. The ratio is the difference in percentage between original and repeated measured SAR.



**Simultaneous Multi-band Transmission Evaluation:**

Application Simultaneous Transmission information:

Position	Simultaneous State
Body	1. GSM + Bluetooth
	2. WCDMA + Bluetooth
	2. LTE + Bluetooth

NOTE:

1. If the test separation distance is <5mm, 5mm is used for excluded SAR calculation.
2. KDB 447498 Appendix E, when standalone SAR test exclusion applies to an antenna that transmits simultaneously with other antennas, the standalone SAR must be estimated according to following to determine simultaneous transmission SAR test exclusion:

$$SAR_{est} = 1.6 \cdot P_{ant} / P_{th} [W/kg].$$

$P_{ant}$  is maximum time-averaged power or effective radiated power (ERP), whichever is greater, and  $P_{th}$  is defined in Formula KDB 447498 (B.2).

Estimated SAR		Antenna to user(cm)	Pant	Pth	Stand Alone SAR(1g) [W/kg]
BLE	Body	≤0.5	0.59	2.75	0.343

Simultaneous Mode	Position	Mode	Max. 1-g SAR	1-g Sum SAR
			(W/kg)	(W/kg)
GSM + BLE	Body	GSM	1.231	1.574
		BLE	0.343	
WCDMA + BLE	Body	WCDMA	0.592	0.935
		BLE	0.343	
LTE + BLE	Body	LTE	1.064	1.407
		BLE	0.343	

Simultaneous transmission SAR test exclusion is determined for each operating configuration and exposure condition according to the reported standalone SAR of each applicable simultaneous transmitting antenna.

When the sum of SAR 1g of all simultaneously transmitting antennas in an operating mode and exposure condition combination is within the SAR limit (SAR-1g 1.6 W/kg), the simultaneous transmission SAR is not required. When the sum of SAR 1g is greater than the SAR limit (SAR-1g 1.6 W/kg), SAR test exclusion is determined by the SPLSR.



### 13. Equipment List

Kind of Equipment	Manufacturer	Type No.	Serial No.	Last Calibration	Calibrated Until
750MHz Dipole	MVG	SID750	SN 30/14 DIP0G750-331	2020.07.14	2023.07.13
835MHz Dipole	MVG	SID835	SN 30/14 DIP0G835-332	2020.07.14	2023.07.13
1800MHz Dipole	MVG	SID1800	SN 30/14 DIP1G800-329	2020.07.14	2023.07.13
1900MHz Dipole	MVG	SID1900	SN 30/14 DIP1G900-333	2020.07.14	2023.07.13
2600MHz Dipole	MVG	SID2600	SN 30/14 DIP2G600-336	2020.07.14	2023.07.13
E-Field Probe	MVG	SSE2	SN 07/21 EPOG352	2022.02.28	2023.02.27
Dielectric Probe Kit	MVG	SCLMP	SN 32/14 OCPG67	2021.11.23	2022.11.22
Antenna	MVG	ANTA3	SN 07/13 ZNTA52	N/A	N/A
Phantom1	MVG	SAM	SN 32/14 SAM115	N/A	N/A
Phantom3	MVG	SAM	SN 21/21 ELLI48	N/A	N/A
Phone holder	MVG	N/A	SN 32/14 MSH97	N/A	N/A
Laptop holder	MVG	N/A	SN 32/14 LSH29	N/A	N/A
Attenuator	Agilent	99899	DC-18GHz	N/A	N/A
Directional coupler	Narda	4226-20	3305	N/A	N/A
Network Analyzer	Agilent	8753ES	US38432810	2021.09.29	2022.09.28
Multi Meter	Keithley	Multi Meter 2000	4050073	2021.10.08	2022.10.07
Signal Generator	Agilent	N5182A	MY50140530	2021.09.30	2022.09.29
Wireless Communication Test Set	Agilent	8960-E5515C	MY48360751	2021.09.30	2022.09.29
Wireless Communication Test Set	R&S	CMW500	156324	2021.09.30	2022.09.29
Power Amplifier	DESAY	ZHL-42W	9638	2021.10.09	2022.10.08
Power Meter	R&S	NRP	100510	2021.09.29	2022.09.28
Power Sensor	R&S	NRP-Z11	101919	2021.09.29	2022.09.28
Power Sensor	Keysight	U2021XA	MY56280002	2021.10.09	2022.10.08
Temperature hygrometer	SuWei	SW-108	N/A	2021.10.09	2022.10.08

Note:  
 Per KDB 865664 D01, Dipole SAR Validation Verification, STS LAB has adopted 3 years calibration intervals. On annual basis, every measurement dipole has been evaluated and is in compliance with the following criteria:

1. There is no physical damage on the dipole
2. System validation with specific dipole is within 10% of calibrated value Return-loss in within 20% of calibrated measurement

## Appendix A. System Validation Plots

### System Performance Check Data (750MHz)

Type: Phone measurement (Complete)

Area scan resolution: dx=8mm, dy=8mm

Zoom scan resolution: dx=8mm, dy=8mm, dz=5mm

Date of measurement: 2022-08-16

### Experimental conditions

Phantom	Validation plane
Device Position	-
Band	750MHz
Channels	-
Signal	CW
Frequency (MHz)	750MHz
Relative permittivity	42.02
Conductivity (S/m)	0.82
Probe	SN 07/21 EPGO352
ConvF	1.58
Crest factor	1:1

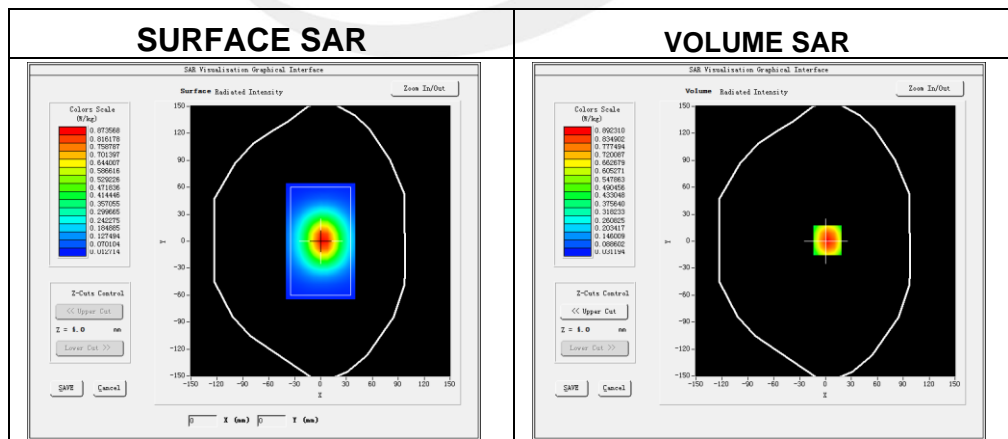

Maximum location: X=2.00, Y=1.00

SAR 10g (W/Kg)	0.547455
SAR 1g (W/Kg)	0.882896

### Z Axis Scan

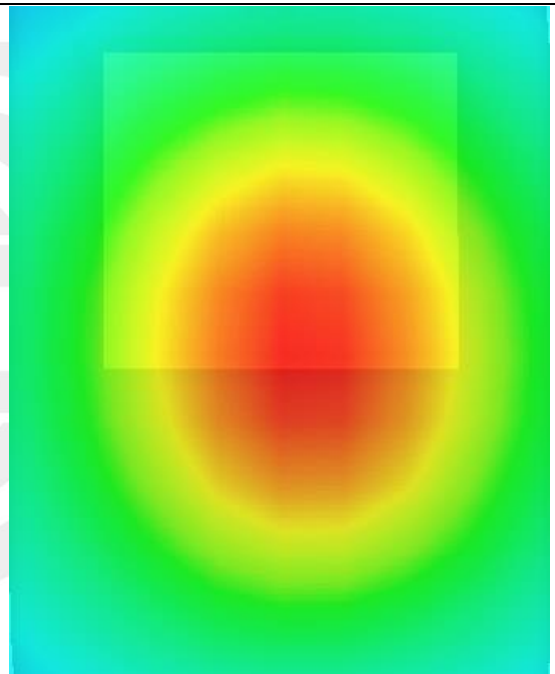
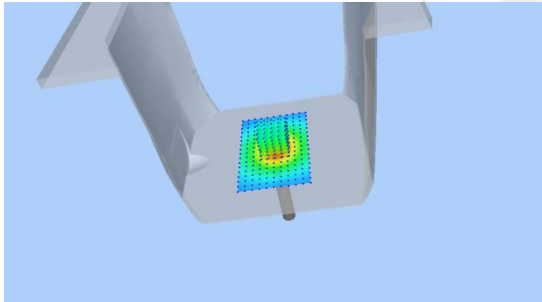
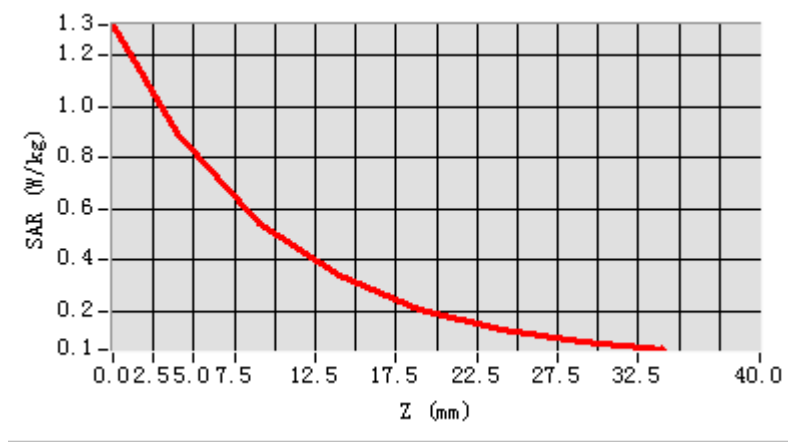



### System Performance Check Data (835MHz)

Type: Phone measurement (Complete)

Area scan resolution: dx=8mm, dy=8mm

Zoom scan resolution: dx=8mm, dy=8mm, dz=5mm

Date of measurement: 2022-08-18

### Experimental conditions

Phantom	Validation plane
Device Position	-
Band	835MHz
Channels	-
Signal	CW
Frequency (MHz)	835MHz
Relative permittivity	41.25
Conductivity (S/m)	0.93
Probe	SN 07/21 EPG0352
ConvF:	1.57
Crest factor:	1:1

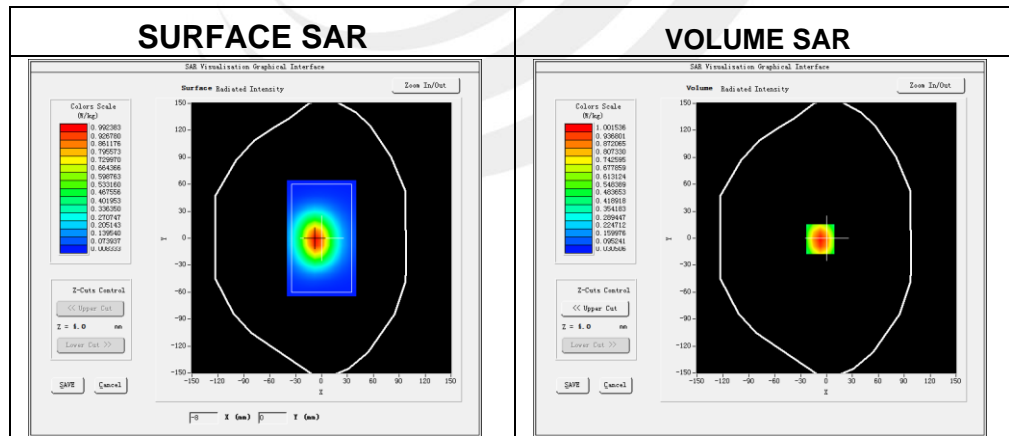

Maximum location: X=-7.00, Y=-1.00

SAR 10g (W/Kg)	0.589135
SAR 1g (W/Kg)	0.951308

### Z Axis Scan

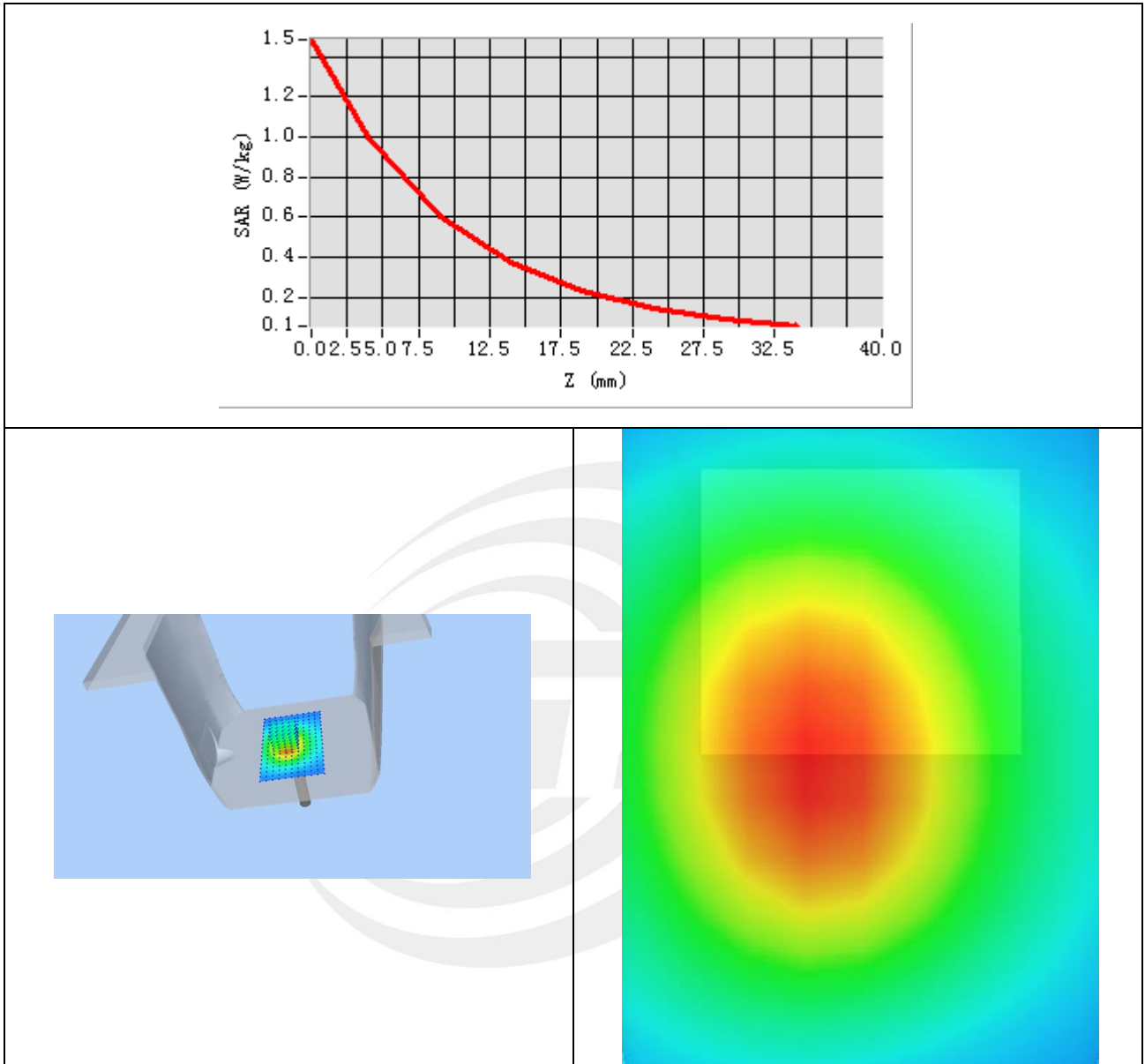



### System Performance Check Data(1800MHz)

Type: Phone measurement (Complete)  
 Area scan resolution: dx=8mm, dy=8mm  
 Zoom scan resolution: dx=8mm, dy=8mm, dz=5mm  
 Date of measurement: 2022-09-20

### Experimental conditions.

Phantom	Validation plane
Device Position	-
Band	1800MHz
Channels	-
Signal	CW
Frequency (MHz)	1800MHz
Relative permittivity	41.13
Conductivity (S/m)	1.42
Probe	SN 07/21 EPGO352
ConvF	1.60
Crest factor:	1:1

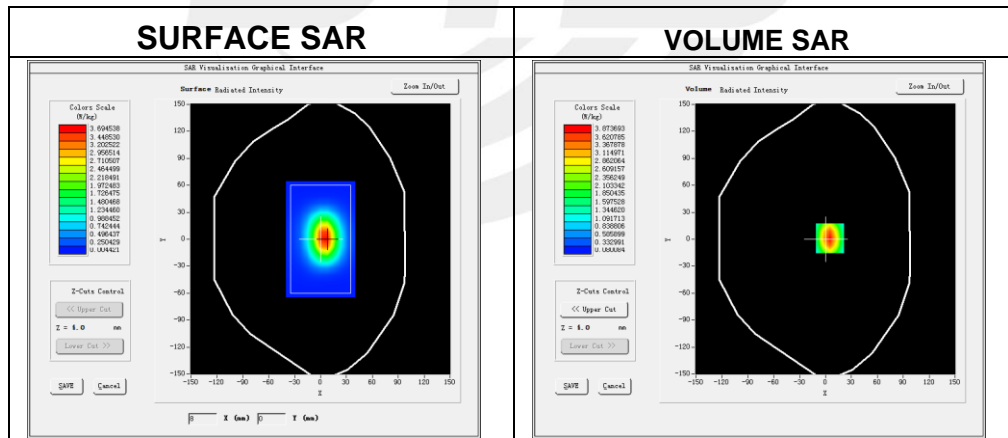

Maximum location: X=5.00, Y=1.00

SAR 10g (W/Kg)	1.998587
SAR 1g (W/Kg)	3.799090

### Z Axis Scan

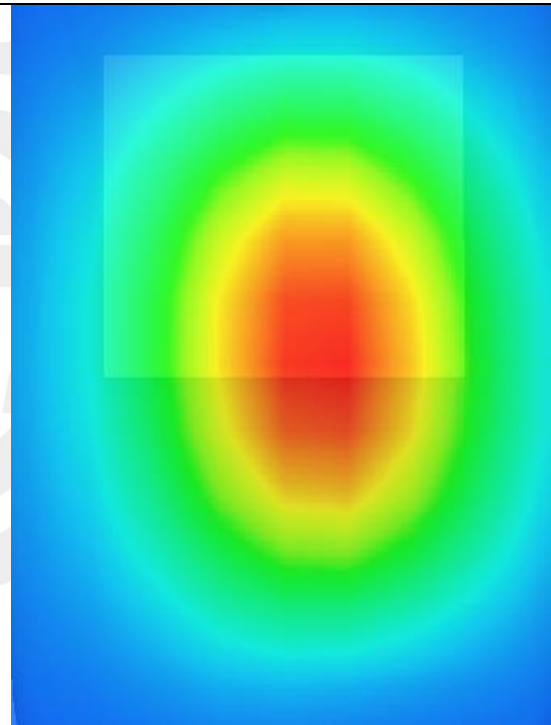
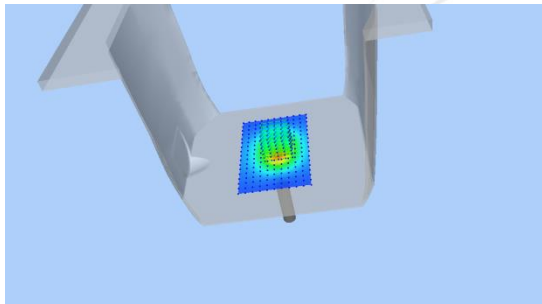
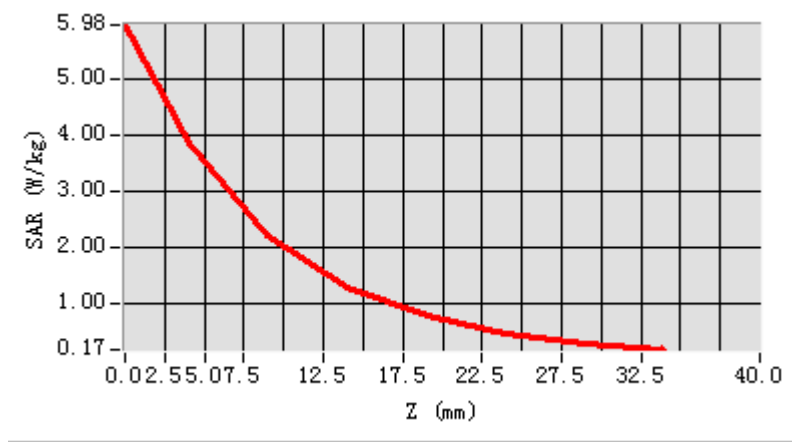



### System Performance Check Data (1900MHz)

Type: Phone measurement (Complete)

Area scan resolution: dx=8mm, dy=8mm

Zoom scan resolution: dx=8mm, dy=8mm, dz=5mm

Date of measurement: 2022-09-23

### Experimental conditions.

Phantom	Validation plane
Device Position	-
Band	1900MHz
Channels	-
Signal	CW
Frequency (MHz)	1900MHz
Relative permittivity	41.05
Conductivity (S/m)	1.35
Probe	SN 07/21 EPGO352
ConvF:	1.78
Crest factor:	1:1

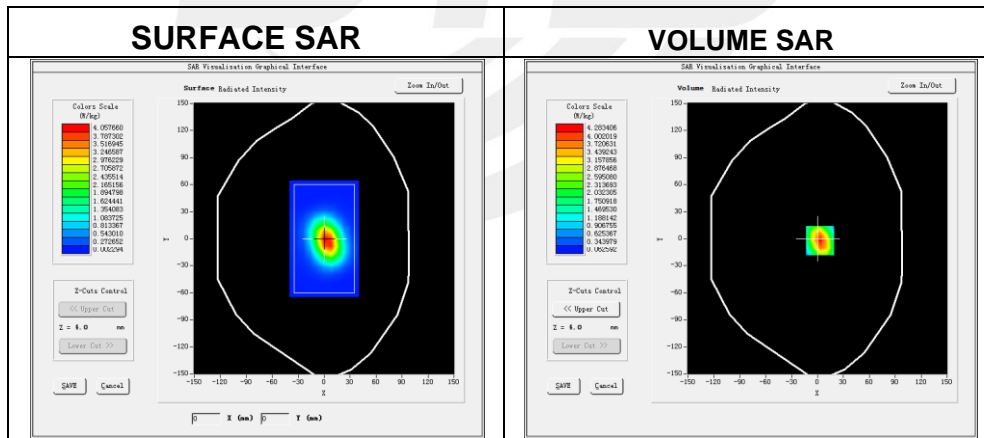

Maximum location: X=3.00, Y=-2.00

SAR 10g (W/Kg)	2.079658
SAR 1g (W/Kg)	3.967038

### Z Axis Scan

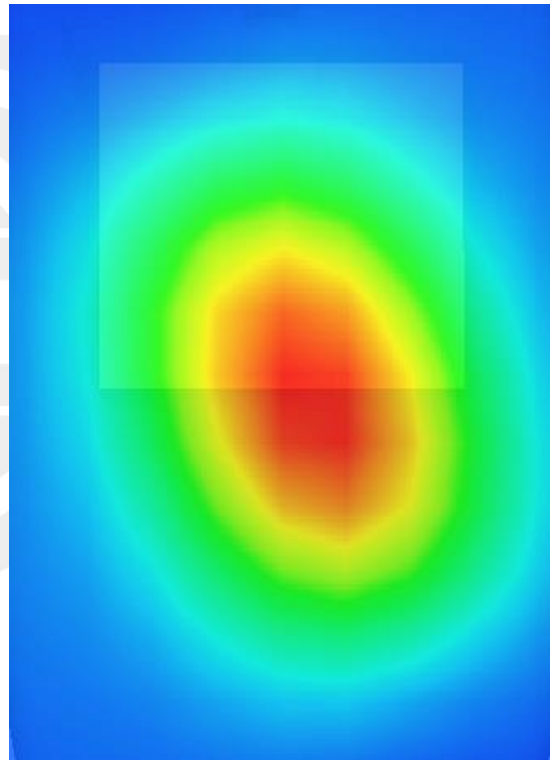
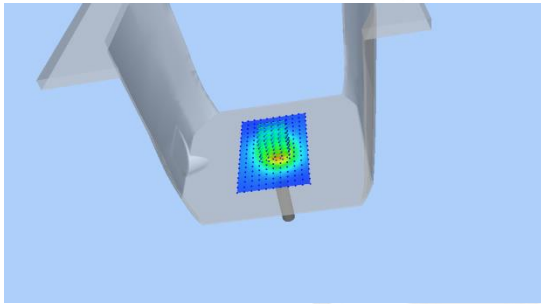
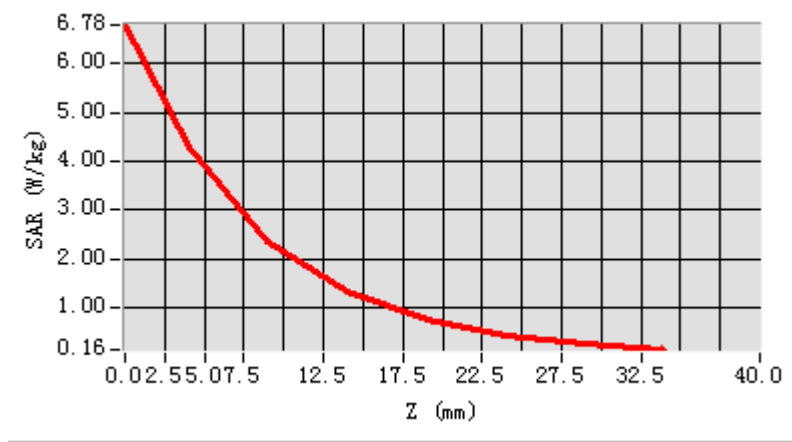

### System Performance Check Data(2600MHz)

Type: Phone measurement (Complete)

Area scan resolution: dx=8mm,dy=8mm

Zoom scan resolution: dx=8mm, dy=8mm, dz=5mm

Date of measurement: 2022-09-26

#### Experimental conditions.

Device Position	Validation plane
Band	2600 MHz
Channels	-
Signal	CW
Frequency (MHz)	2600
Relative permittivity	39.48
Conductivity (S/m)	1.99
Probe	SN 07/21 EPGO352
ConvF	1.63
Crest factor:	1:1

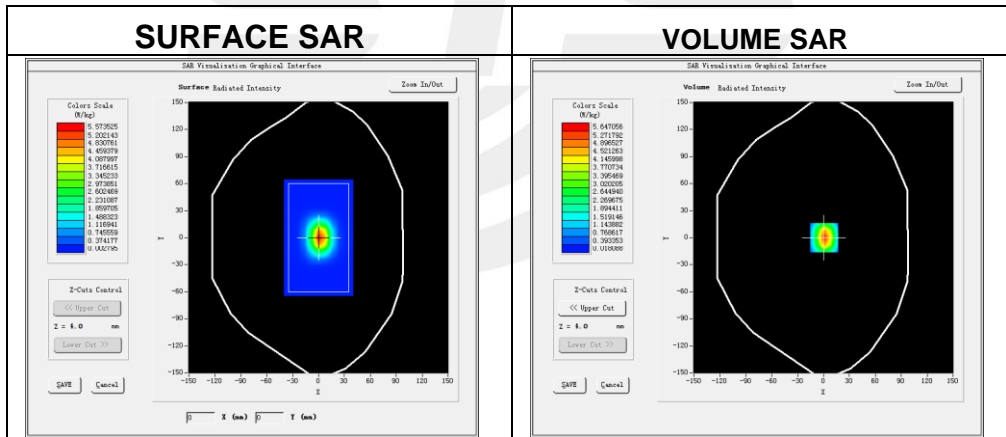

Maximum location: X=1.00, Y=0.00

SAR 10g (W/Kg)	2.462601
SAR 1g (W/Kg)	5.542867

### Z Axis Scan

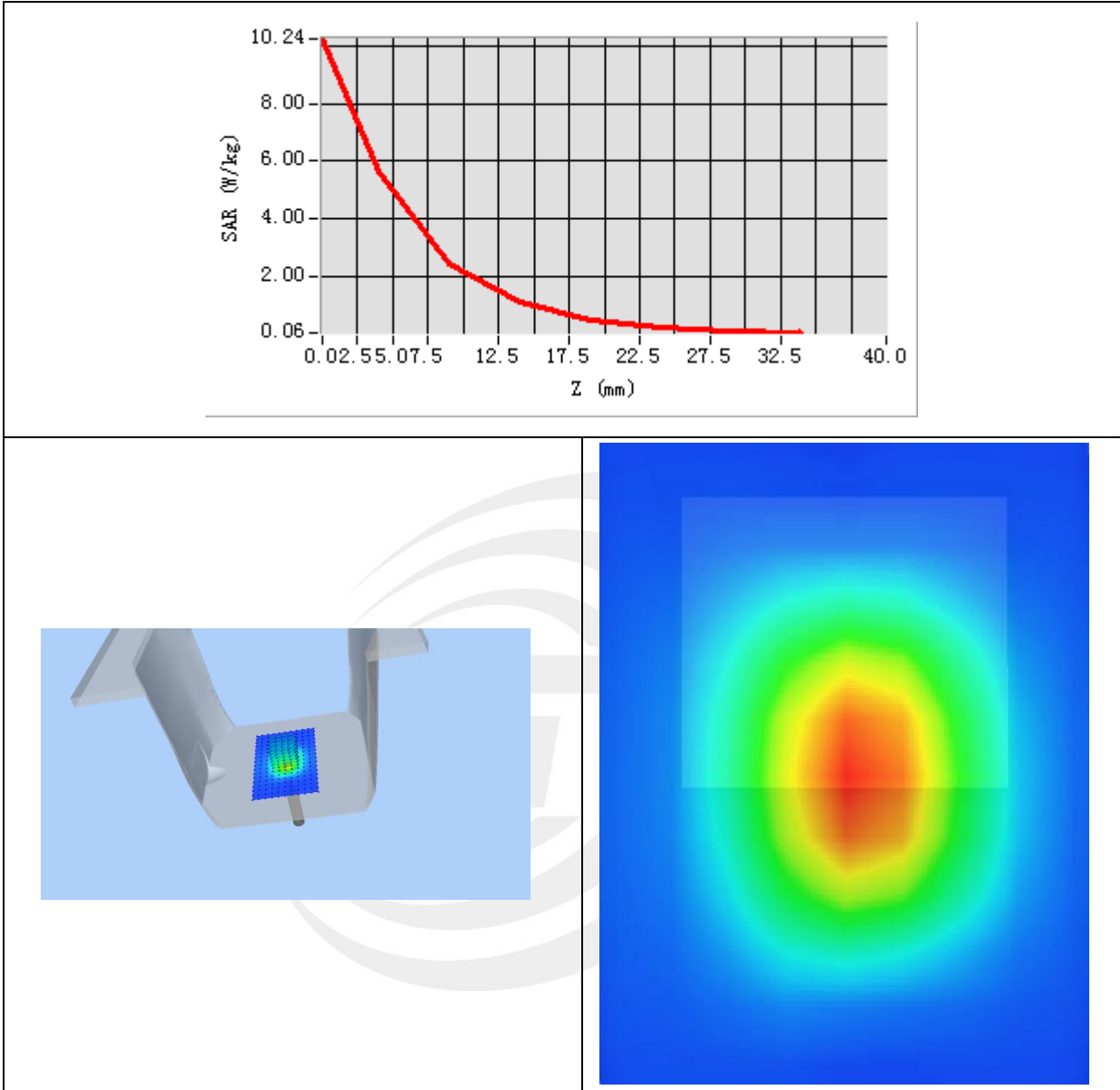



## Appendix B. SAR Test Plots

### Plot 1: DUT: GPS Tracker; EUT Model: TRKM110-T

Test Date	2022-08-16
Probe	SN 07/21 EPGO352
Area Scan	dx=8mm, dy=8mm, h= 5.00 mm
Zoom Scan	5x5x7, dx=8mm, dy=8mm, dz=5mm, Complete/ndx=8mm, dy=8mm, h= 5.00 mm
Phantom	Validation plane
Device Position	Front Side
Band	GPRS 850
Signal	Duty Cycle: 2.00 (Crest factor: 2.0)
Frequency (MHz)	824.2
Relative permittivity (real part)	42.25
Conductivity (S/m)	0.92

Maximum location: X=17.00, Y=25.00

SAR Peak: 0.37 W/kg

SAR 10g (W/Kg)	0.156638
SAR 1g (W/Kg)	0.247413

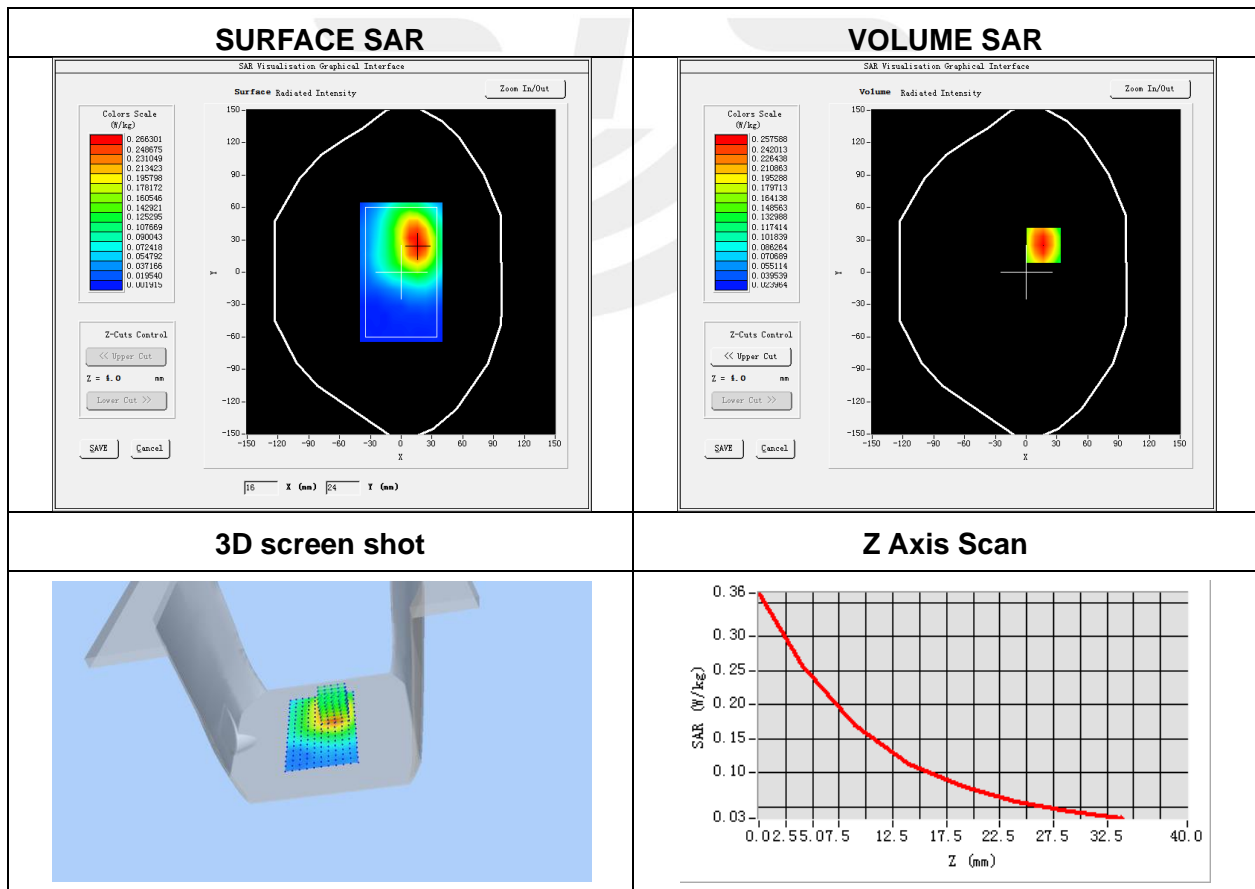

**Plot 2: DUT: GPS Tracker; EUT Model: TRKM110-T**

Test Date	2022-09-23
Probe	SN 07/21 EPGO352
Area Scan	dx=8mm, dy=8mm, h= 5.00 mm
Zoom Scan	5x5x7, dx=8mm, dy=8mm, dz=5mm, Complete/ndx=8mm, dy=8mm, h= 5.00 mm
Phantom	Validation plane
Device Position	Front Side
Band	GPRS 1900
Signal	Duty Cycle: 2.00 (Crest factor: 2.0)
Frequency (MHz)	1850.2
Relative permittivity (real part)	41.16
Conductivity (S/m)	1.41

Maximum location: X=12.00, Y=-11.00

SAR Peak: 2.00 W/kg

SAR 10g (W/Kg)	0.645348
SAR 1g (W/Kg)	1.209098

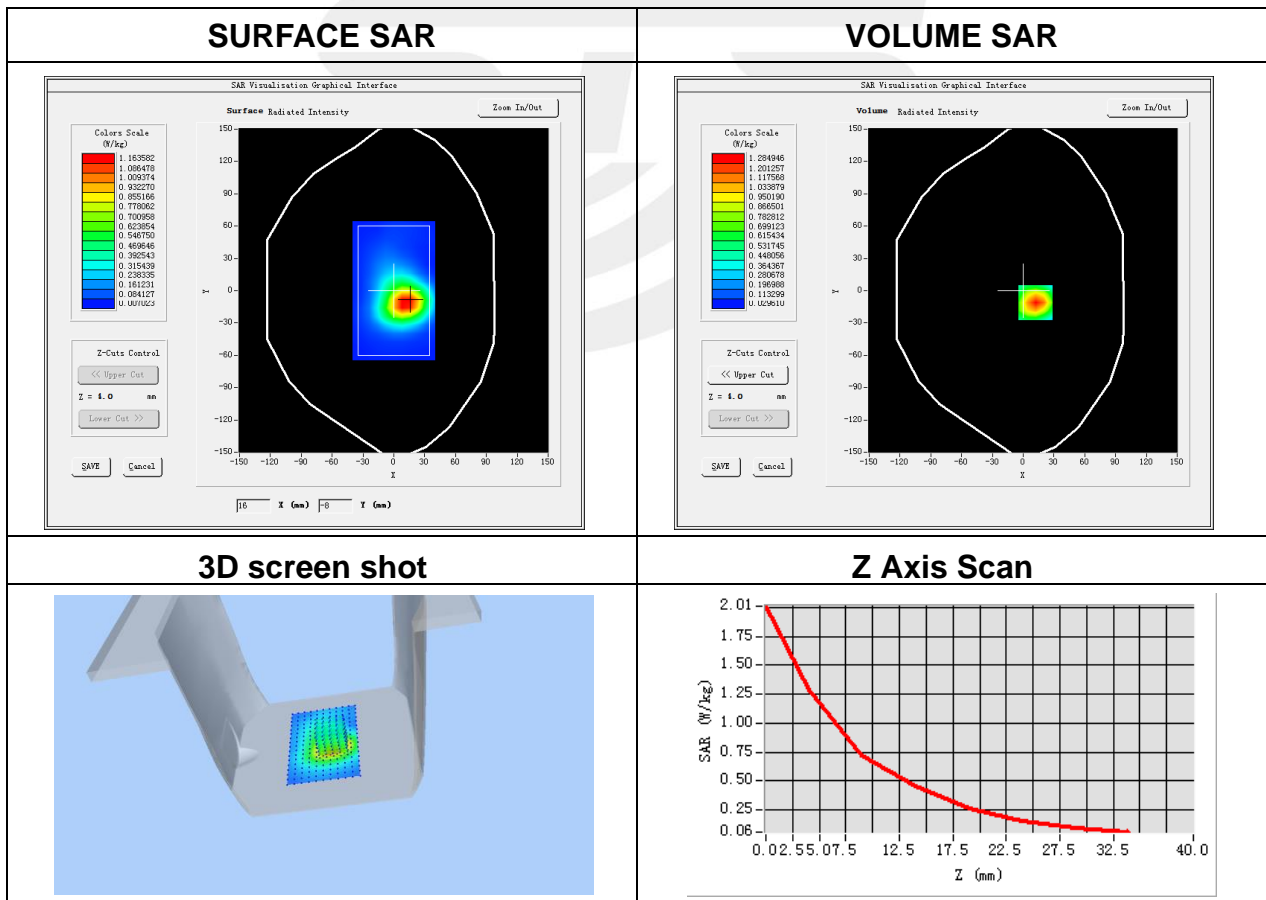

**Plot 3: DUT: GPS Tracker; EUT Model: TRKM110-T**

Test Date	2022-09-23
Probe	SN 07/21 EPGO352
ConvF	1.84
Area Scan	dx=8mm, dy=8mm, h= 5.00 mm
Zoom Scan	5x5x7, dx=8mm, dy=8mm, dz=5mm, Complete/ndx=8mm, dy=8mm, h= 5.00 mm
Phantom	Validation plane
Device Position	Front Side
Band	WCDMA II
Signal	WCDMA (Crest factor: 1.0)
Frequency (MHz)	1852.4
Relative permittivity (real part)	40.66
Conductivity (S/m)	1.36

Maximum location: X=7.00, Y=9.00

SAR Peak: 0.85 W/kg

SAR 10g (W/Kg)	0.358684
SAR 1g (W/Kg)	0.575210

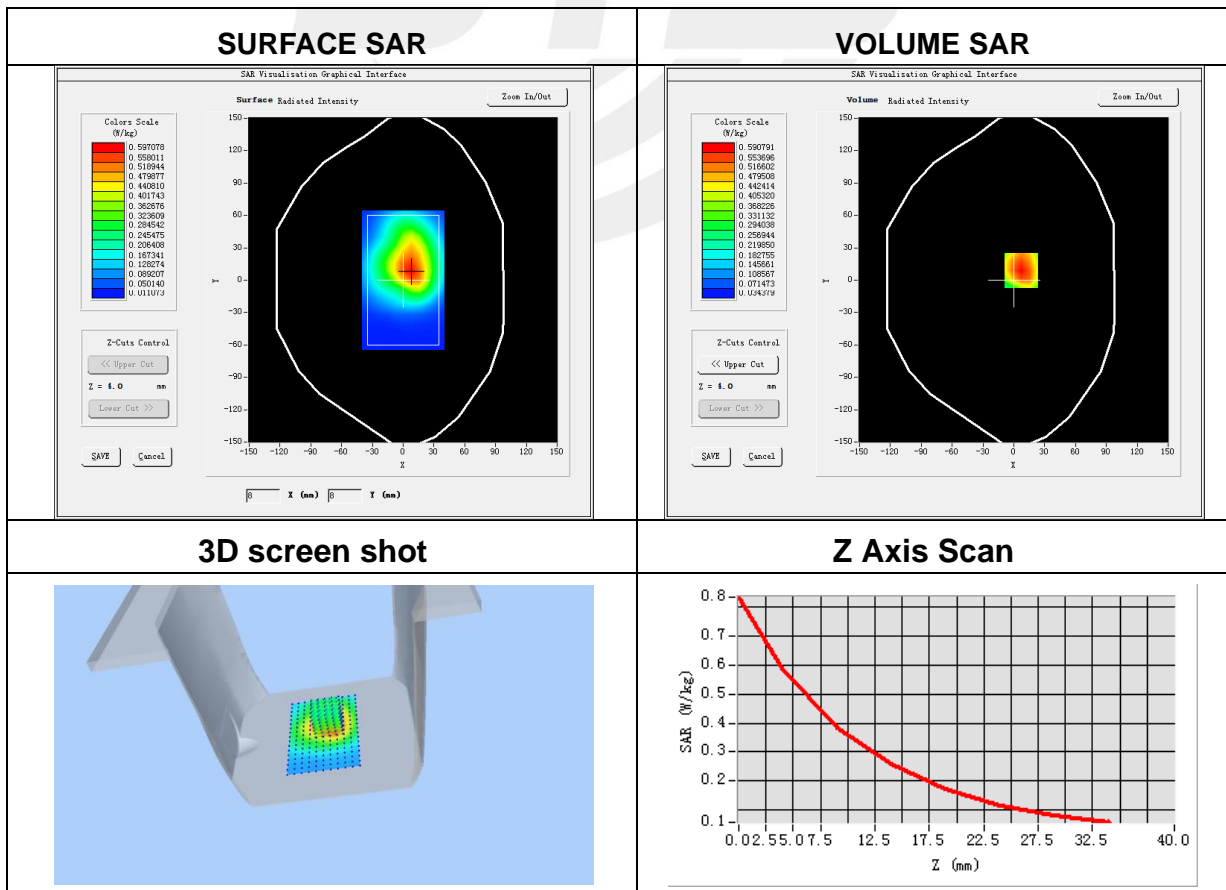

**Plot 4: DUT: GPS Tracker; EUT Model: TRKM110-T**

Test Date	2022-08-16
Probe	SN 07/21 EPGO352
ConvF	1.60
Area Scan	dx=8mm, dy=8mm, h= 5.00 mm
Zoom Scan	5x5x7, dx=8mm, dy=8mm, dz=5mm, Complete/ndx=8mm, dy=8mm, h= 5.00 mm
Phantom	Validation plane
Device Position	Front Side
Band	WCDMA V
Signal	WCDMA (Crest factor: 1.0)
Frequency (MHz)	836.6
Relative permittivity (real part)	40.62
Conductivity (S/m)	0.93

Maximum location: X=18.00, Y=25.00

SAR Peak: 0.23 W/kg

SAR 10g (W/Kg)	0.102790
SAR 1g (W/Kg)	0.158875

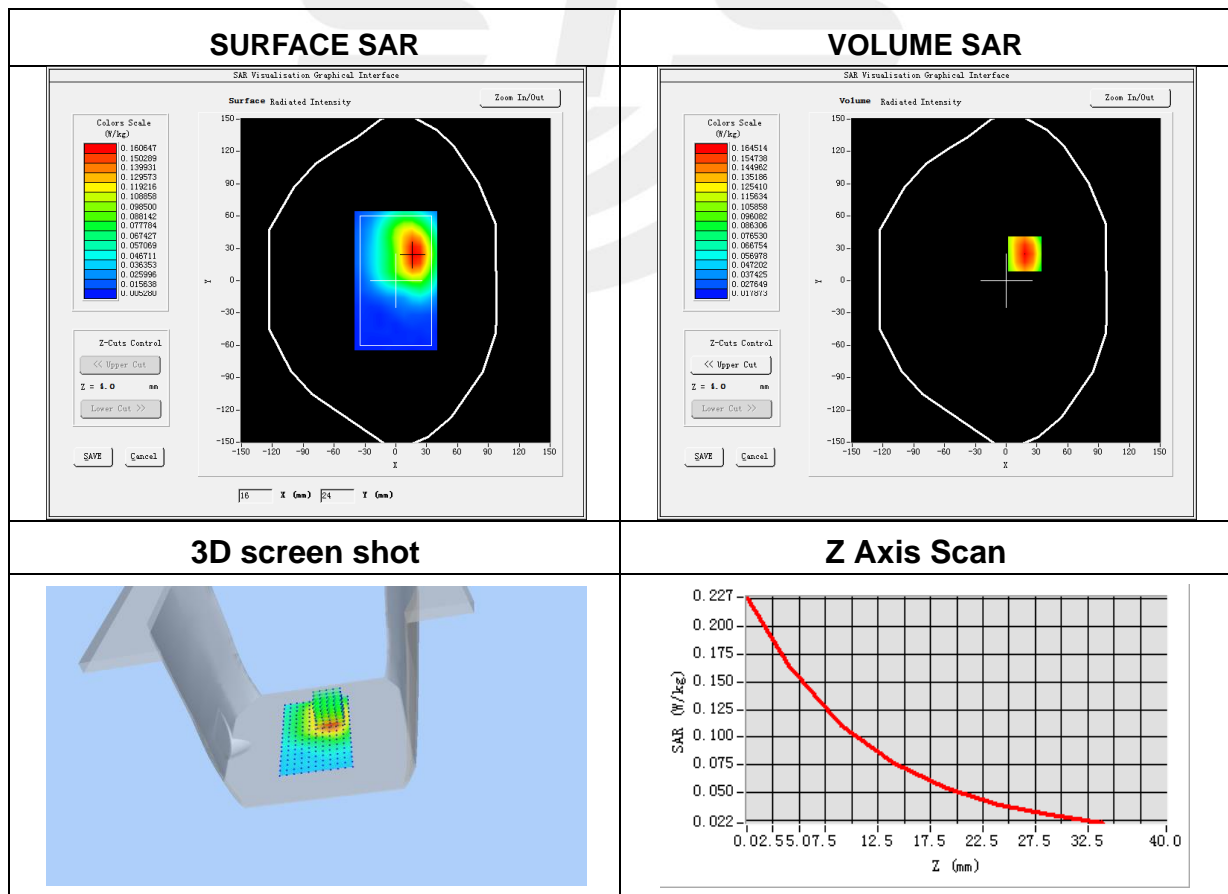

**Plot 5: DUT: GPS Tracker; EUT Model: TRKM110-T**

Test Date	2022-09-23
Probe	SN 07/21 EPGO352
Area Scan	dx=8mm, dy=8mm, h= 5.00 mm
Zoom Scan	5x5x7, dx=8mm, dy=8mm, dz=5mm, Complete/ndx=8mm, dy=8mm, h= 5.00 mm
Phantom	Validation plane
Device Position	Front side
Band	LTE Band 2(RB 1)
Signal	LTE (Crest factor: 1.0)
Frequency (MHz)	1860
Relative permittivity (real part)	40.22
Conductivity (S/m)	1.36

Maximum location: X=6.00, Y=46.00

SAR Peak: 0.77 W/kg

SAR 10g (W/Kg)	0.256277
SAR 1g (W/Kg)	0.492439

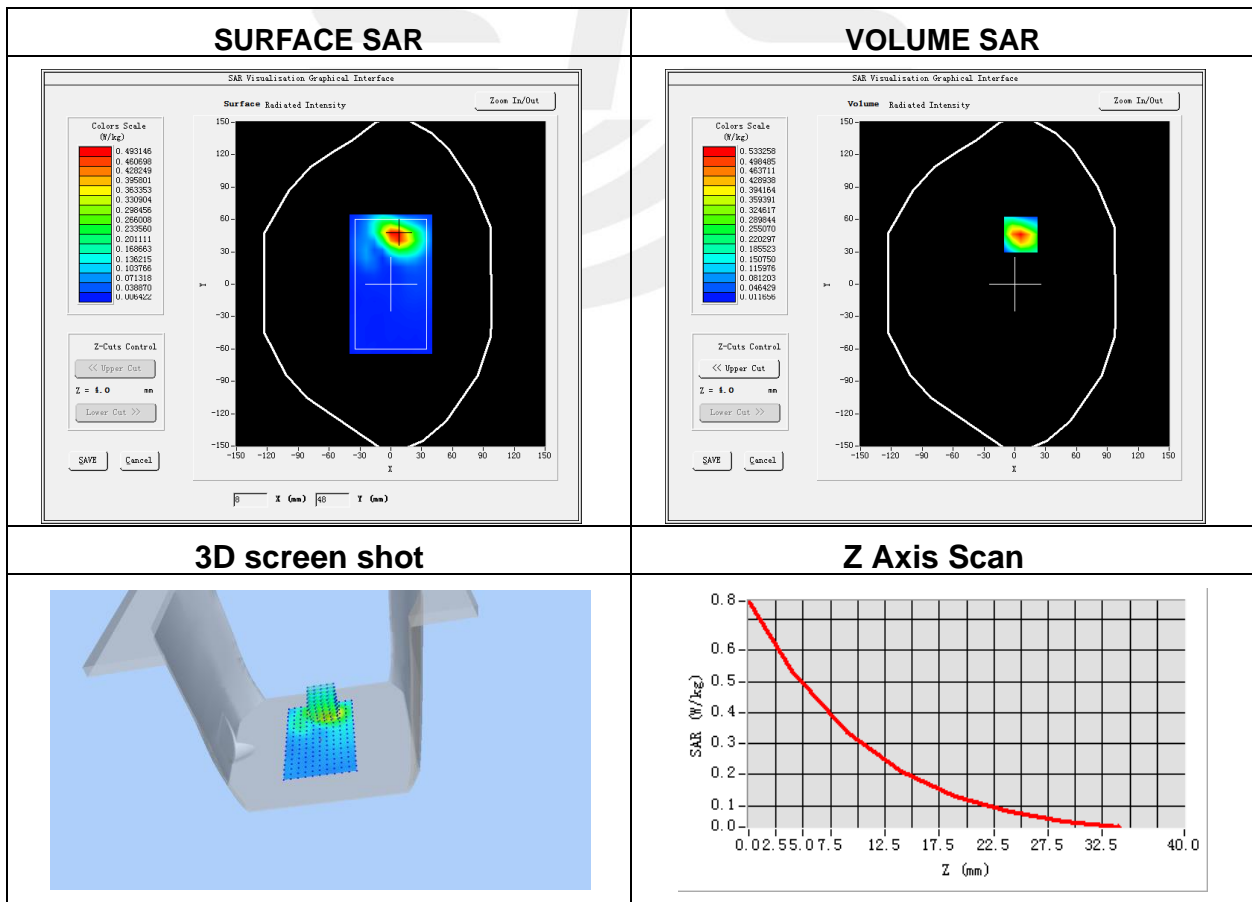

**Plot 6: DUT: GPS Tracker; EUT Model: TRKM110-T**

Test Date	2022-08-24
Probe	SN 07/21 EPGO352
Area Scan	dx=8mm, dy=8mm, h= 5.00 mm
Zoom Scan	5x5x7, dx=8mm, dy=8mm, dz=5mm, Complete/ndx=8mm, dy=8mm, h= 5.00 mm
Phantom	Validation plane
Device Position	Front side
Band	LTE Band 4 (RB 1)
Signal	LTE (Crest factor: 1.0)
Frequency (MHz)	1732.5
Relative permittivity (real part)	41.15
Conductivity (S/m)	1.35

Maximum location: X=-8.00, Y=45.00

SAR Peak: 0.68 W/kg

SAR 10g (W/Kg)	0.224034
SAR 1g (W/Kg)	0.431885

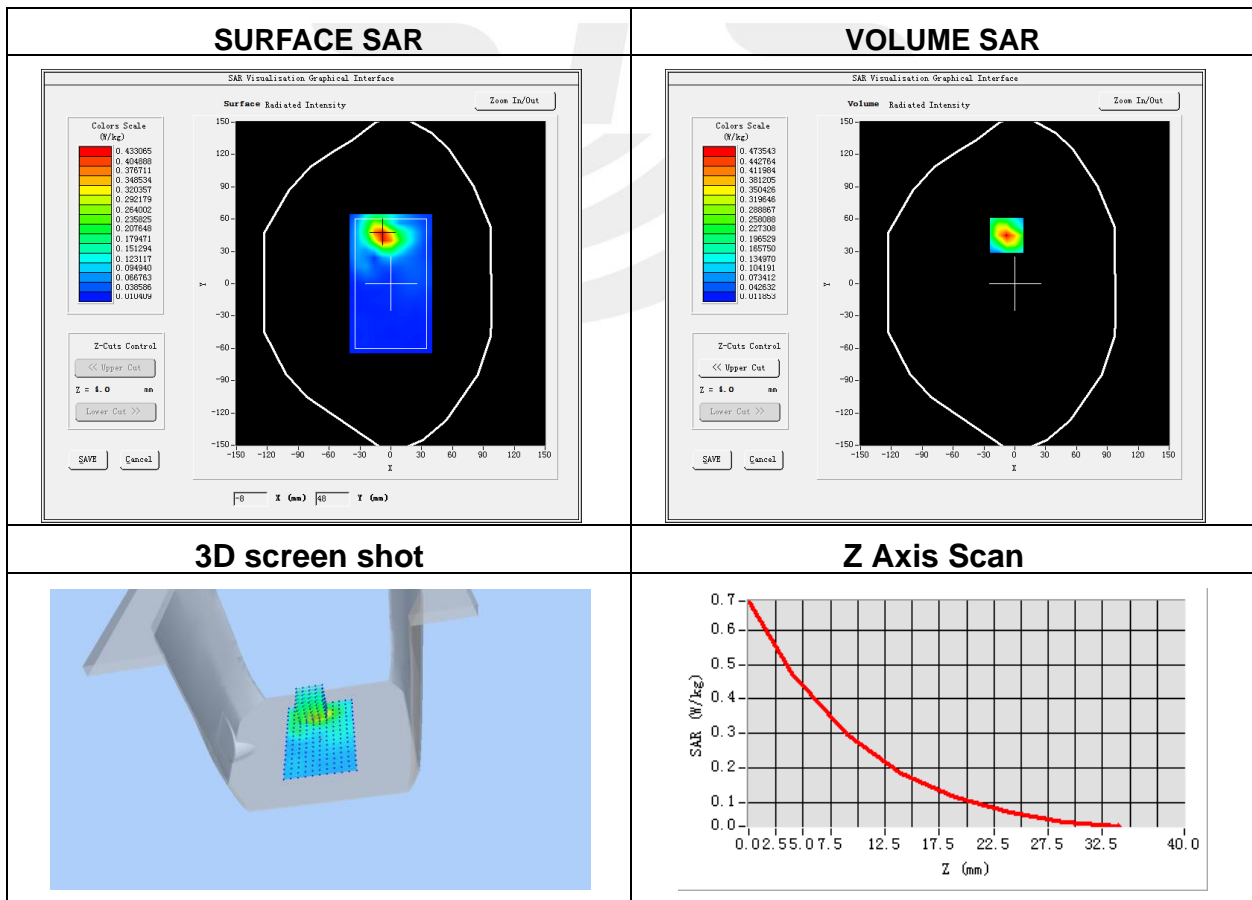



**Plot 7: DUT: GPS Tracker; EUT Model: TRKM110-T**

Test Date	2022-08-24
Probe	SN 07/21 EPGO352
Area Scan	dx=8mm, dy=8mm, h= 5.00 mm
Zoom Scan	5x5x7, dx=8mm, dy=8mm, dz=5mm, Complete/ndx=8mm, dy=8mm, h= 5.00 mm
Phantom	Validation plane
Device Position	Front side
Band	LTE Band 5 (RB 1)
Signal	LTE (Crest factor: 1.0)
Frequency (MHz)	836.5
Relative permittivity (real part)	41.23
Conductivity (S/m)	0.94

Maximum location: X=21.00, Y=7.00

SAR Peak: 0.26 W/kg

SAR 10g (W/Kg)	0.115540
SAR 1g (W/Kg)	0.178206

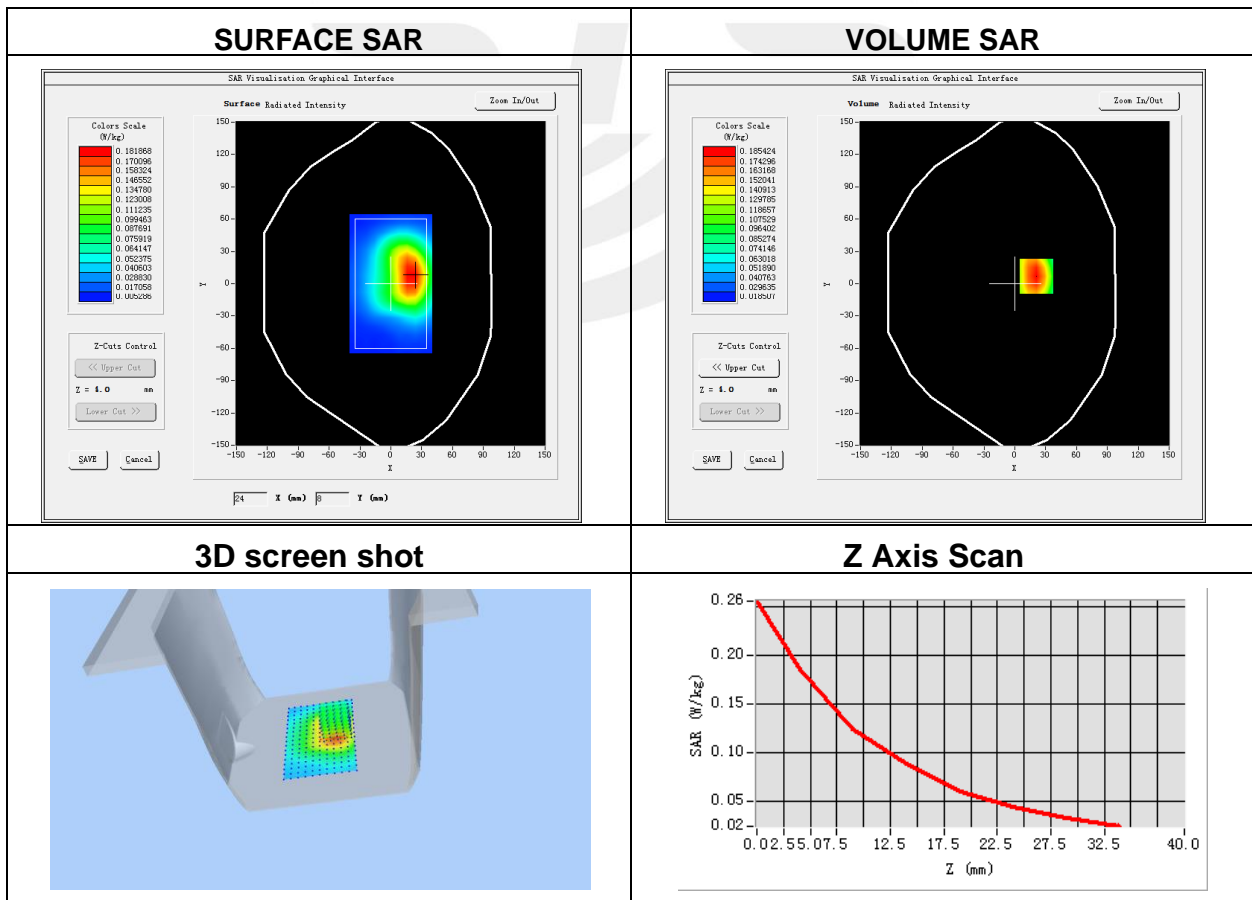

**Plot 8: DUT: GPS Tracker; EUT Model: TRKM110-T**

Test Date	2022-09-26
Probe	SN 07/21 EPGO352
Area Scan	dx=8mm, dy=8mm, h= 5.00 mm
Zoom Scan	5x5x7, dx=8mm, dy=8mm, dz=5mm, Complete/ndx=8mm, dy=8mm, h= 5.00 mm
Phantom	Validation plane
Device Position	Front side
Band	LTE Band 7 (RB 1)
Signal	LTE (Crest factor: 1.0)
Frequency (MHz)	2560
Relative permittivity (real part)	39.44
Conductivity (S/m)	1.94

Maximum location: X=-8.00, Y=26.00

SAR Peak: 1.74 W/kg

SAR 10g (W/Kg)	0.458332
SAR 1g (W/Kg)	0.963602

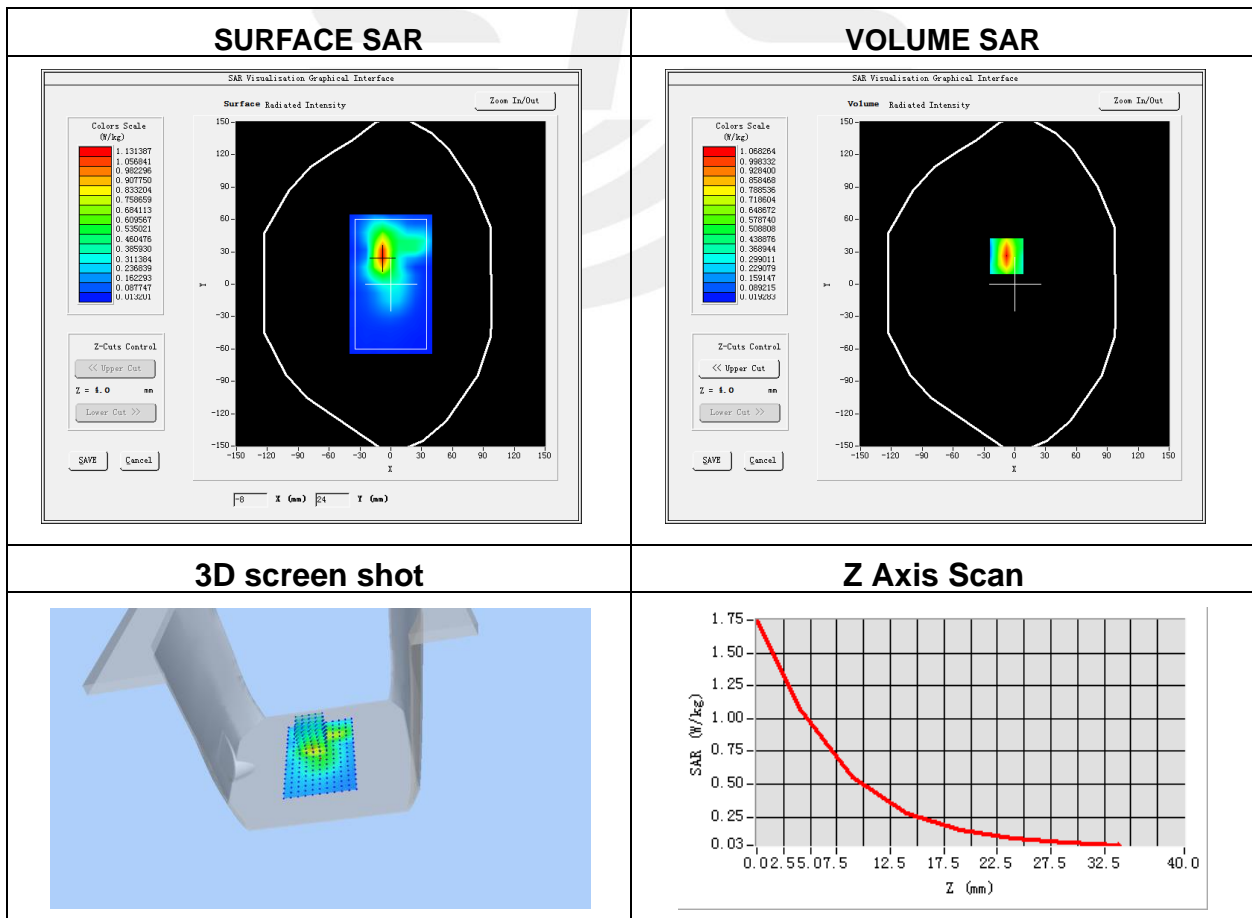

**Plot 9: DUT: GPS Tracker; EUT Model: TRKM110-T**

Test Date	2022-08-24
Probe	SN 07/21 EPGO352
Area Scan	dx=8mm, dy=8mm, h= 5.00 mm
Zoom Scan	5x5x7, dx=8mm, dy=8mm, dz=5mm, Complete/ndx=8mm, dy=8mm, h= 5.00 mm
Phantom	Validation plane
Device Position	Front side
Band	LTE Band 12 (RB 1)
Signal	LTE (Crest factor: 1.0)
Frequency (MHz)	711
Relative permittivity (real part)	42.69
Conductivity (S/m)	0.91

Maximum location: X=-9.00, Y=27.00

SAR Peak: 0.34 W/kg

SAR 10g (W/Kg)	0.157179
SAR 1g (W/Kg)	0.239857

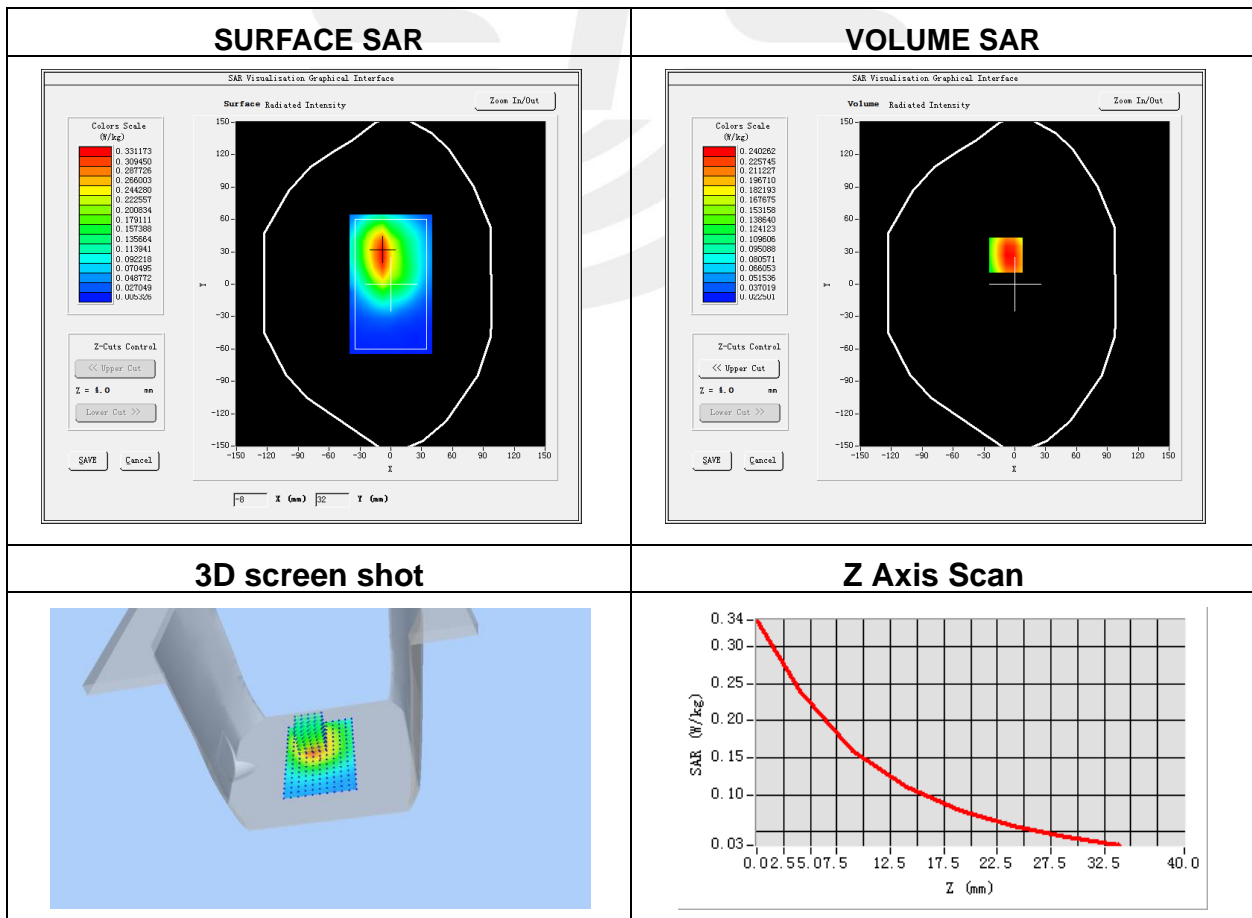

**Plot 10: DUT: GPS Tracker; EUT Model: TRKM110-T**

Test Date	2022-08-24
Probe	SN 07/21 EPGO352
Area Scan	dx=8mm, dy=8mm, h= 5.00 mm
Zoom Scan	5x5x7, dx=8mm, dy=8mm, dz=5mm, Complete/ndx=8mm, dy=8mm, h= 5.00 mm
Phantom	Validation plane
Device Position	Front side
Band	LTE Band 13 (RB 1)
Signal	LTE (Crest factor: 1.0)
Frequency (MHz)	782
Relative permittivity (real part)	42.77
Conductivity (S/m)	0.88

Maximum location: X=-8.00, Y=24.00

SAR Peak: 1.11 W/kg

SAR 10g (W/Kg)	0.493712
SAR 1g (W/Kg)	0.763629

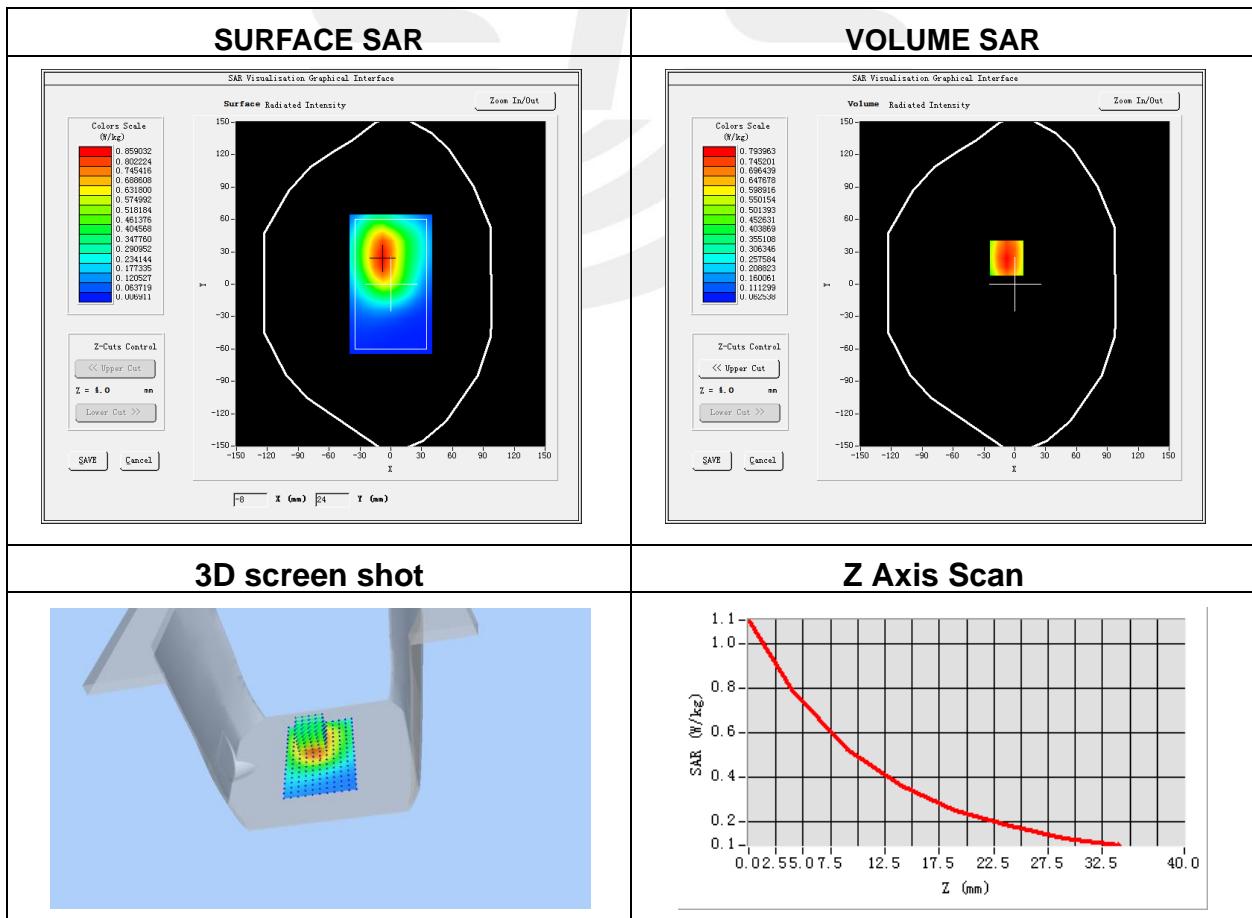

**Plot 11: DUT: GPS Tracker; EUT Model: TRKM110-T**

Test Date	2022-08-24
Probe	SN 07/21 EPGO352
Area Scan	dx=8mm, dy=8mm, h= 5.00 mm
Zoom Scan	5x5x7, dx=8mm, dy=8mm, dz=5mm, Complete/ndx=8mm, dy=8mm, h= 5.00 mm
Phantom	Validation plane
Device Position	Front side
Band	LTE Band 17 (RB 1)
Signal	LTE (Crest factor: 1.0)
Frequency (MHz)	711
Relative permittivity (real part)	42.69
Conductivity (S/m)	0.91

Maximum location: X=-15.00, Y=23.00

SAR Peak: 0.32 W/kg

SAR 10g (W/Kg)	0.143391
SAR 1g (W/Kg)	0.221401

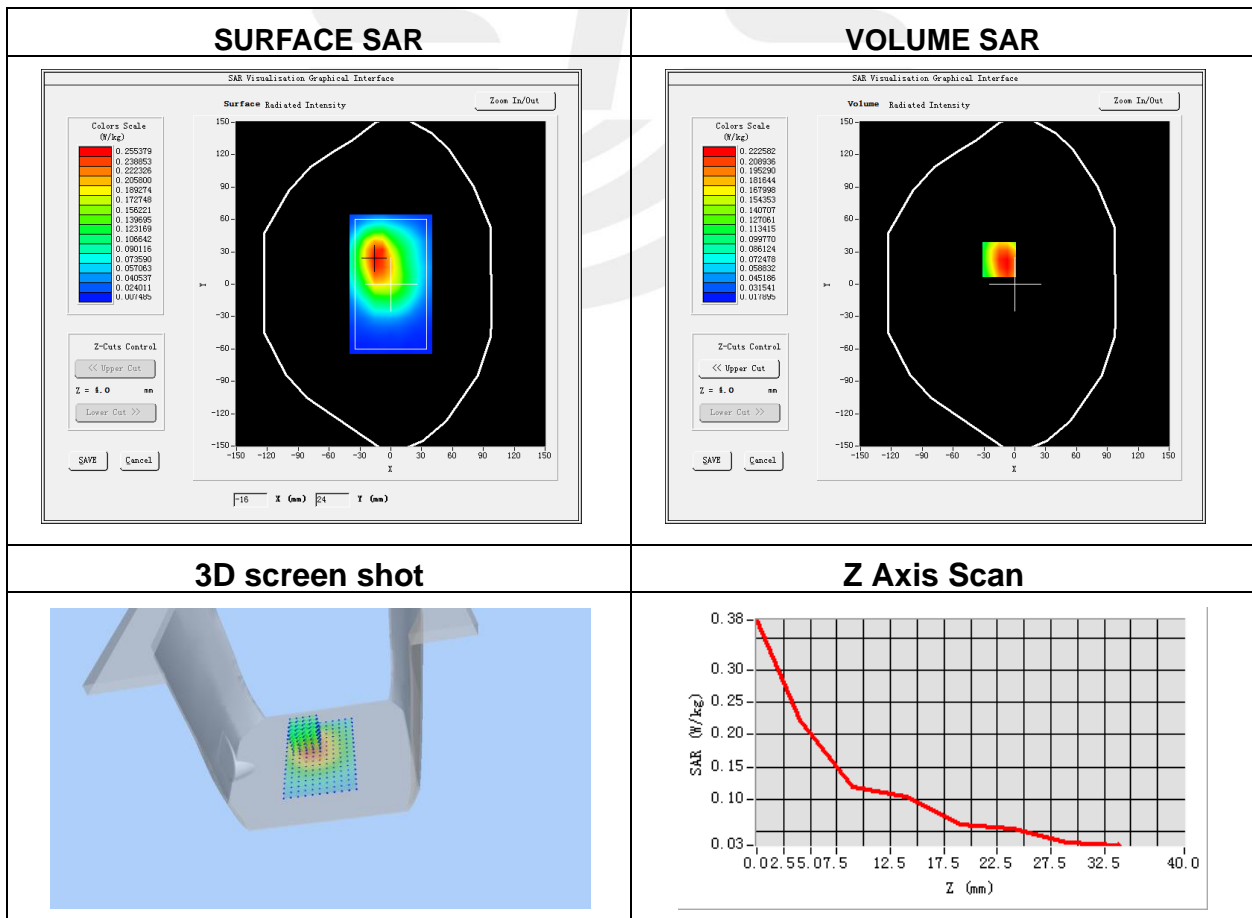

**Plot 12: DUT: GPS Tracker; EUT Model: TRKM110-T**

Test Date	2022-08-24
Probe	SN 07/21 EPGO352
Area Scan	dx=8mm, dy=8mm, h= 5.00 mm
Zoom Scan	5x5x7, dx=8mm, dy=8mm, dz=5mm, Complete/ndx=8mm, dy=8mm, h= 5.00 mm
Phantom	Validation plane
Device Position	Front side
Band	LTE Band 25 (RB 1)
Signal	LTE (Crest factor: 1.0)
Frequency (MHz)	1860
Relative permittivity (real part)	40.22
Conductivity (S/m)	1.36

Maximum location: X=6.00, Y=3.00

SAR Peak: 0.79 W/kg

SAR 10g (W/Kg)	0.270507
SAR 1g (W/Kg)	0.513899

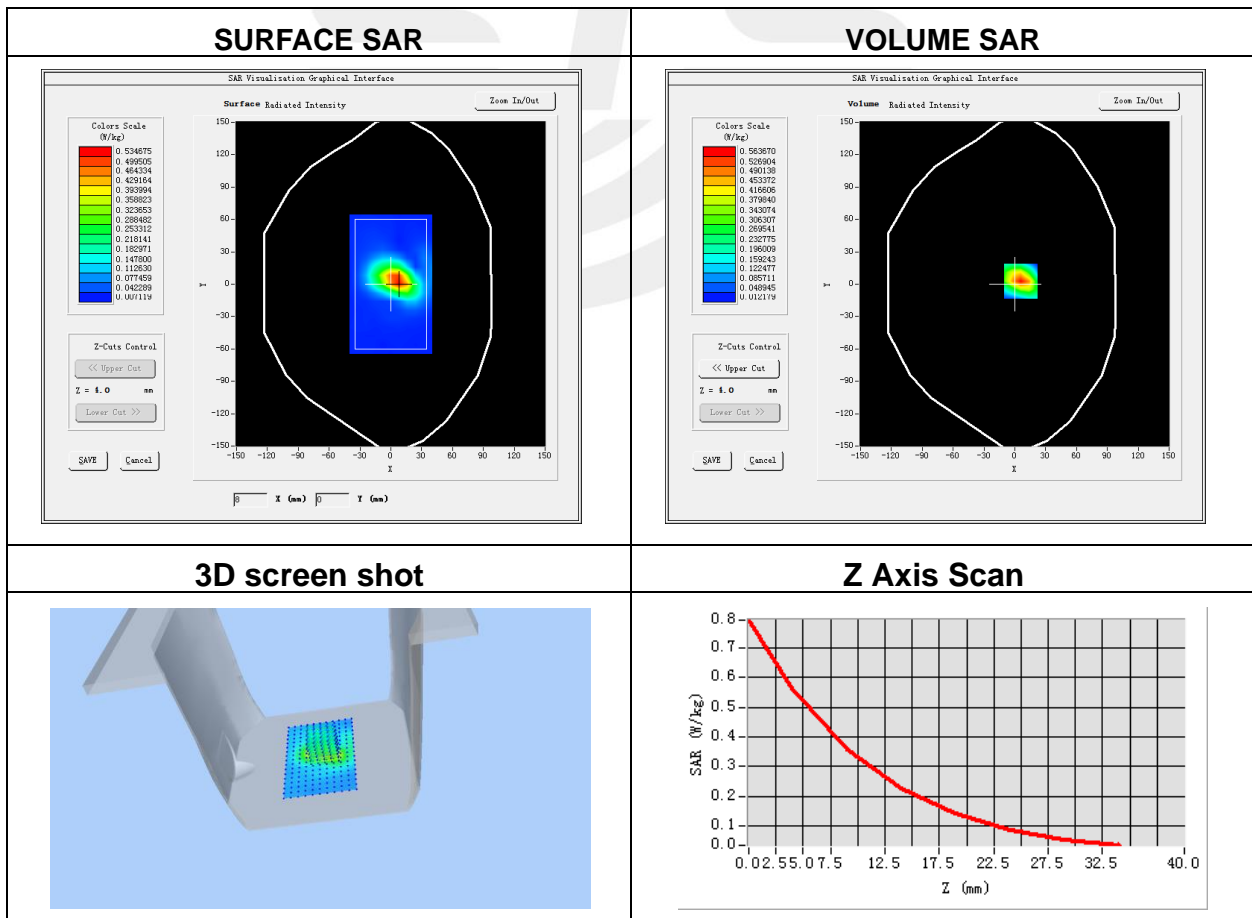



**Plot 13: DUT: GPS Tracker; EUT Model: TRKM110-T**

Test Date	2022-08-24
Probe	SN 07/21 EPGO352
Area Scan	dx=8mm, dy=8mm, h= 5.00 mm
Zoom Scan	5x5x7, dx=8mm, dy=8mm, dz=5mm, Complete/ndx=8mm, dy=8mm, h= 5.00 mm
Phantom	Validation plane
Device Position	Front side
Band	LTE Band 26 (RB 1)
Signal	LTE (Crest factor: 1.0)
Frequency (MHz)	841.5
Relative permittivity (real part)	41.09
Conductivity (S/m)	0.86

Maximum location: X=17.00, Y=26.00

SAR Peak: 0.31 W/kg

SAR 10g (W/Kg)	0.145893
SAR 1g (W/Kg)	0.219783

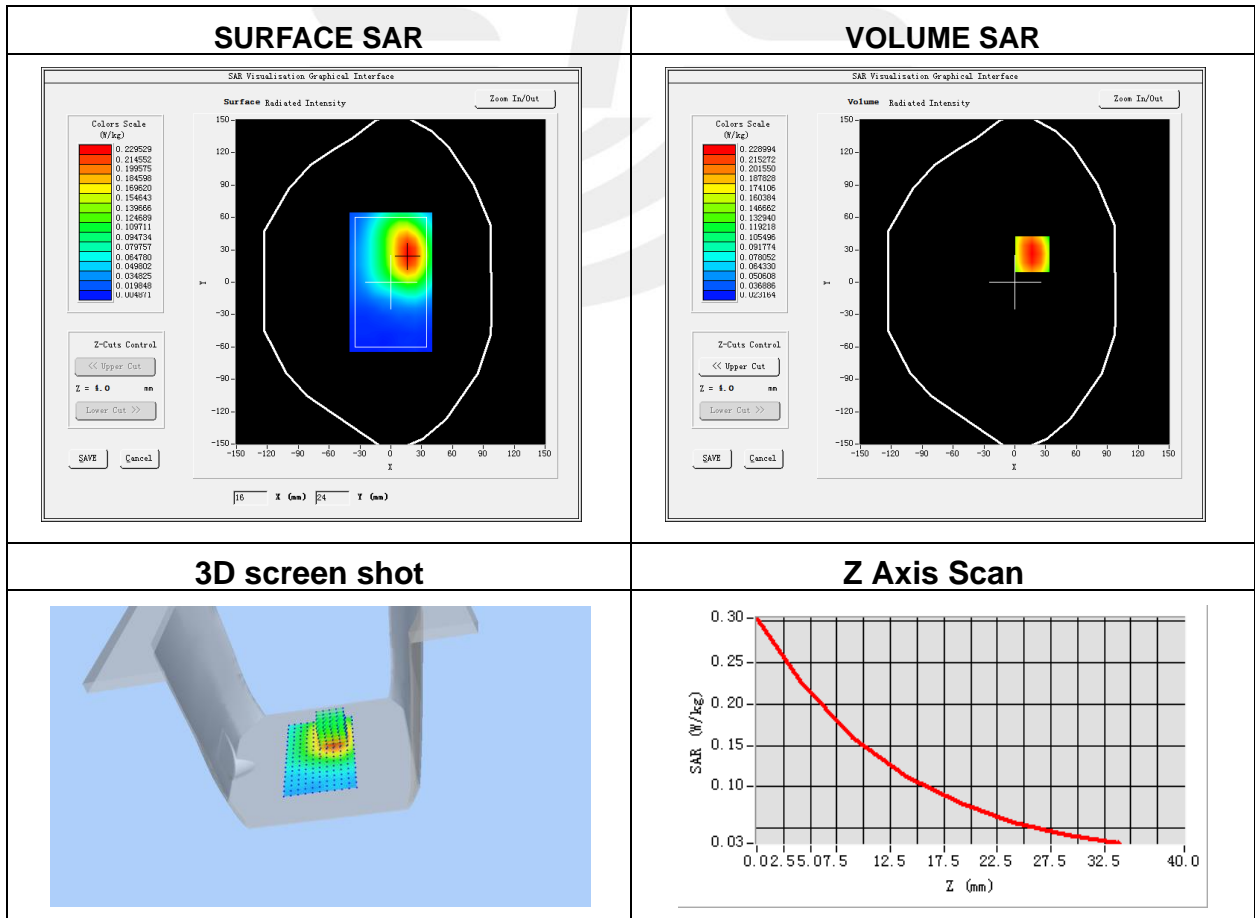

**Plot 14: DUT: GPS Tracker; EUT Model: TRKM110-T**

Test Date	2022-08-16
Probe	SN 07/21 EPGO352
Area Scan	dx=8mm, dy=8mm, h= 5.00 mm
Zoom Scan	5x5x7, dx=8mm, dy=8mm, dz=5mm, Complete/ndx=8mm, dy=8mm, h= 5.00 mm
Phantom	Validation plane
Device Position	Front side
Band	LTE Band 41 (RB 1)
Signal	LTE (Crest factor: 1.0)
Frequency (MHz)	2593
Relative permittivity (real part)	39.98
Conductivity (S/m)	2.01

Maximum location: X=-5.00, Y=26.00

SAR Peak: 0.49 W/kg

SAR 10g (W/Kg)	0.159147
SAR 1g (W/Kg)	0.296961

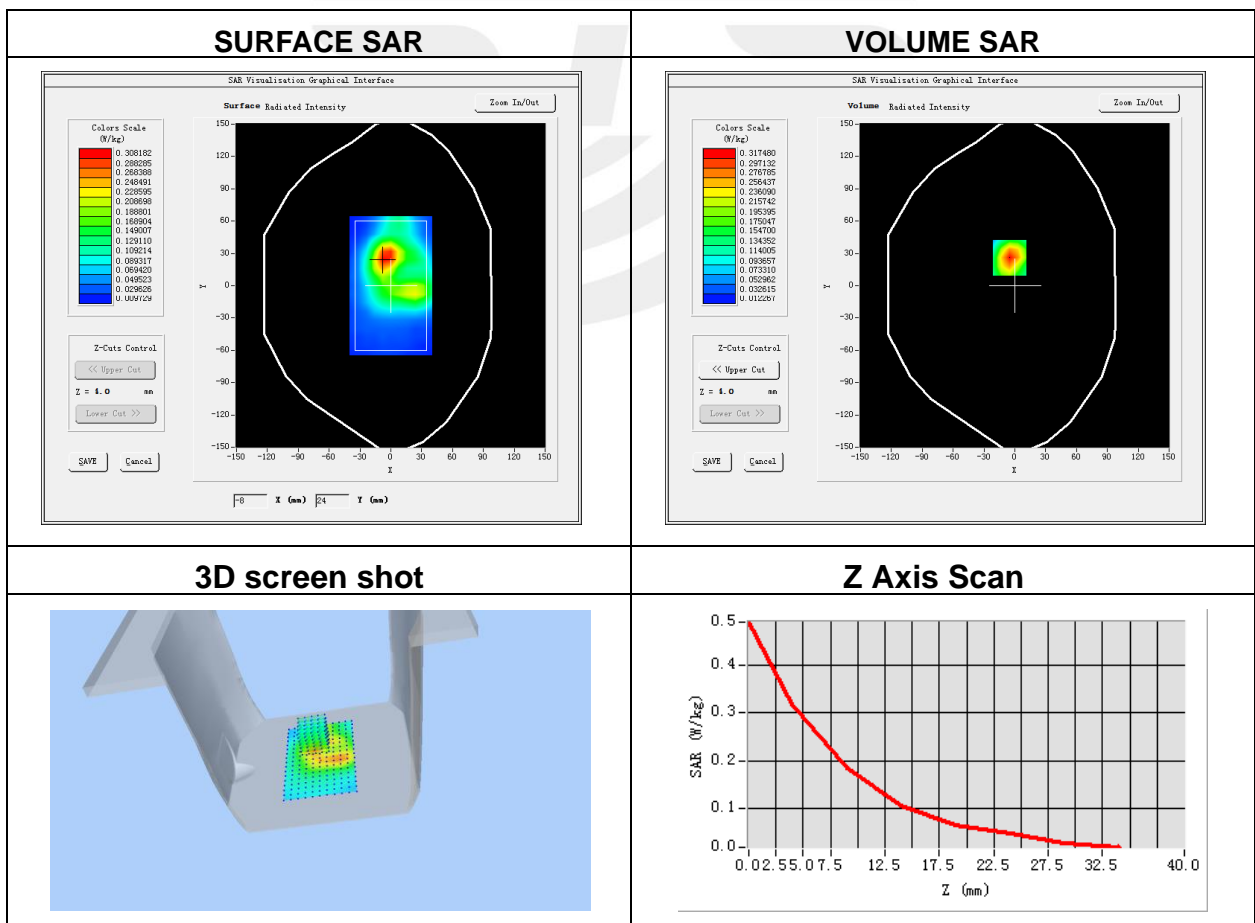



## Appendix C. Probe Calibration and Dipole Calibration Report

Refer the appendix Calibration Report.

※※※※END OF THE REPORT※※※※

