

Radio Test Report

Report No.: STS2310308W09

Issued for

Trackimo INC.

680 Central Ave, Cedarhurst, New York 11516, USA

Product Name: GPS Tracker

Brand Name: Trackimo, Tracki

Model Name: TRKM035

Series Model(s): TRKM032, TRKM031

FCC ID: 2AAI6-TRKM035

Test Standards: 47 CFR Part 2, 22, 24, 27, 90

Any reproduction of this document must be done in full. No single part of this document may be reproduced without permission from STS, all test data presented in this report is only applicable to presented test sample.



TEST REPORT

Applicant's Name: Trackimo INC.
Address.....: 680 Central Ave, Cedarhurst, New York 11516, USA
Manufacturer's Name: Trackimo INC.
Address.....: 680 Central Ave, Cedarhurst, New York 11516, USA

Product Description

Product Name: GPS Tracker
Brand Name.....: Trackimo, Tracki
Model Name.....: TRKM035
Series Model(s): TRKM032, TRKM031
Test Standards.....: 47 CFR Part 2, 22, 24, 27, 90
Test Procedure.....: KDB 971168 D01 v03r01,ANSI C63.26(2015)

This device described above has been tested by STS, the test results show that the equipment under test (EUT) is in compliance with the FCC requirements. And it is applicable only to the tested sample identified in the report.
This report shall not be reproduced except in full, without the written approval of STS, this document may be altered or revised by STS, personal only, and shall be noted in the revision of the document..

Date of Test.....:
Date of receipt of test item: 17 Oct. 2023
Date (s) of performance of tests : 17 Oct. 2023 ~ 02 Nov. 2023
Date of Issue: 02 Nov. 2023
Test Result: Pass

Testing Engineer : [Signature]
(Lenon Hou)

Technical Manager : [Signature]
(Chris Chen)

Authorized Signatory : [Signature]
(Bovey Yang)





Table of Contents	Page
1 INTRODUCTION	7
1.1 TEST FACTORY	7
1.2 MEASUREMENT UNCERTAINTY	7
2 PRODUCT INFORMATION	8
3 TEST CONFIGURATION OF EQUIPMENT UNDER TEST	12
4 MEASUREMENT INSTRUMENTS	15
5 TEST ITEMS	16
5.1 CONDUCTED OUTPUT POWER&TRANSMITTER RADIATED POWER	16
5.2 PEAK TO AVERAGE RATIO	62
5.3 OCCUPIED BANDWIDTH	63
5.4 FREQUENCY STABILITY	64
5.5 SPURIOUS EMISSIONS AT ANTENNA TERMINALS	74
5.6 BAND EDGE	75
5.7 FIELD STRENGTH OF SPURIOUS RADIATION MEASUREMENT	77
APPENDIX-PHOTOS OF TEST SETUP	130



Revision History

Rev.	Issue Date	Report No.	Effect Page	Contents
00	02 Nov. 2023	STS2310308W09	ALL	Initial Issue



SUMMARY OF TEST RESULTS

Test procedures according to the technical standards:

The radiated emission testing was performed according to the procedures of KDB 971168 D01 v03r01 and ANSI C63.26(2015)

Test Description	FCC Rules	Band	Test Limit	Test Result
Conducted Output Power	2.1046	/	Reporting Only	PASS
Transmitter Radiated Power	22.913	B5, B26	ERP < 7 Watt	PASS
	24.232(c)	B2, B25	EIRP < 2Watt	
	27.50(c)	B12, B17	ERP < 3 Watt	
	27.50(d)	B4	EIRP < 1Watt	
	27.50(h)	B7	EIRP < 2Watt	
	90.635(b)	B26	ERP < 100Watt	
Peak-to-Average Ratio	22.913(d)	B5, B26	< 13 dB	PASS
	24.232(d)	B2, B25		
	27.50	B4, B7, B12, B17		
Occupied Bandwidth	2.1049	/	Reporting Only	PASS
Frequency Stability	2.1055	/	< 2.5 ppm	PASS
	22.355	B5, B26		
	24.235	B2, B25		
	27.54	B4, B7, B12,		
	90.213	B26		
Spurious Emission at Antenna Terminals	2.1051	/	< 43+10log10(P[Watts])	PASS
	22.917	B5, B26		
	24.238(a)	B2, B25		
	27.53(g)	B12, B17		



	27.53(h)	B4		
	90.691	B26		
	27.53(m)	B7	$< 55+10\log_{10}(P[\text{Watts}])$	
Band Edge	2.1051	/	Please refer to standard	PASS
	22.917	B5, B26		
	24.238(a)	B2, B25		
	27.53(g)	B12, B17		
	27.53(h)	B4		
	27.53(m)	B7		
	90.691	B26		
Field Strength of Spurious Radiation	2.1053	/	$< 43+10\log_{10}(P[\text{Watts}])$	PASS
	22.917	B5, B26		
	24.238(a)	B2, B25		
	27.53(g)	B12, B17		
	27.53(h)	B4		
	90.691	B26		
	27.53(m)	B7	$< 55+10\log_{10}(P[\text{Watts}])$	



1 INTRODUCTION

1.1 TEST FACTORY

SHENZHEN STS TEST SERVICES CO., LTD

Add. : 101, Building B, Zhuoke Science Park, No.190 Chongqing Road, ZhanChengShequ, Fuhai Sub-District, Bao'an District, Shenzhen, Guang Dong, China

FCC test Firm Registration Number: 625569

IC test Firm Registration Number: 12108A

A2LA Certificate No.: 4338.01

1.2 MEASUREMENT UNCERTAINTY

The measurement uncertainties shown below were calculated in accordance with the requirements of ANSI C63.4-2014. All measurement uncertainty values are shown with a coverage factor of $k = 2$ to indicate a 95% level of confidence. The measurement data shown herein meets or exceeds the UCISPR measurement uncertainty values specified in CISPR 16-4-2 and, thus, can be compared directly to specified limits to determine compliance.

No.	Item	Uncertainty
1	RF output power, conducted	± 1.197 dB
2	Unwanted Emissions, conducted	± 2.896 dB
3	All emissions, radiated 9K-30MHz	± 3.84 dB
4	All emissions, radiated 30M-1GHz	± 3.94 dB
5	All emissions, radiated 1G-6GHz	± 4.59 dB
6	All emissions, radiated >6G	± 5.22 dB
7	Conducted Emission (9KHz-150KHz)	± 2.14 dB
8	Conducted Emission (150KHz-30MHz)	± 2.54 dB



2 PRODUCT INFORMATION

Product Name	GPS Tracker
Brand Name	Trackimo, Tracki
Model Name	TRKM035
Series Model(s)	TRKM032, TRKM031
Model Difference	The difference only in the model name and brand name.
Tx Frequency:	GPRS/EDGE: 850: 824 MHz ~ 849MHz 1900: 1850 MHz ~ 1910MHz WCDMA: Band V: 824 MHz ~ 849 MHz Band II: 1850 MHz ~ 1910 MHz LTE Band 2:1850~1910MHz LTE Band 4:1710~1755MHz LTE Band 5:824~849MHz LTE Band 7:2500~2570MHz LTE Band 12:699~716MHz LTE Band 17:704~716MHz LTE Band 25:1850~1915MHz LTE Band 26 Part 90: 814-824MHz LTE Band 26 Part 22: 824-849 MHz
Rx Frequency:	GPRS/EDGE: 850: 869 MHz ~ 894 MHz 1900: 1930 MHz ~ 1990MHz WCDMA: Band V: 869 MHz~ 894 MHz Band II: 1930 MHz ~ 1990 MHz LTE Band 2:1930 ~1990MHz LTE Band 4:2110~2155MHz LTE Band 5:869~894MHz LTE Band 7:2620~2690MHz LTE Band 12:729~746MHz LTE Band 17:734~746MHz LTE Band 25:1930~1995MHz LTE Band 26 Part 90: 859-869MHz LTE Band 26 Part 22: 859~894MHz
Max RF Output Power:	GSM850: 30.39dBm, PCS1900: 31.49dBm WCDMA Band V:23.09dBm, WCDMA Band II:23.14dBm



Modulation Characteristics:	GMSK for GPRS; GMSK and 8PSK for EDGE WCDMA: QPSK; HSDPA:QPSK/16QAM; HSUPA:BPSK LTE: QPSK /16QAM
SIM Card:	Only support single SIM Card.
Antenna:	LDS
Antenna gain:	GSM 850: -1.15dBi ,PCS 1900: 1.48dBi WCDMA 850: -1.15dBi, WCDMA1900: 1.48dBi, LTE: B2:1.48dBi,LTE: B4:1.82dBi,LTE: B5:-1.15dBi LTE: B7:2.01dBi,LTE: B12:-5.85,LTE: B17:-5.85dBi LTE: B25:1.48dBi,LTE: B26:-0.98dBi
Battery parameter:	Rated Voltage: 3.8V Charge Limit Voltage: 4.35V Capacity: 800mAh
Rating:	Input: DC 5V 390mA
GPRS/EDGE Class:	Multi-Class12
Extreme Vol. Limits:	DC 2.97V~ DC 3.63V(Normal: DC 3.3V)
Extreme Temp. Tolerance:	-10°C to +50°C
Hardware version number:	UC01 PCB V0.2
Software version number:	UC01 V0.2
<p><i>** Note: The High Voltage 3.63V and Low Voltage 2.97V was declared by manufacturer, The EUT couldn't be operate normally with higher or lower voltage, the antenna information refer the manufacturer provide report, applicable only to the tested sample identified in the report.</i></p>	



2.1 EMISSION DESIGNATOR

Mode	Emission Designator (99%OBW)
GPRS850	247KGXW
EGPRS850	252KG7W
GPRS1900	247KGXW
EGPRS1900	248KG7W

Mode	Emission Designator (99%OBW)
WCDMA 850	4M15F9W
HSDPA 850	4M16F9W
HSUPA 850	4M16F9W
WCDMA 1900	4M16F9W
HSDPA 1900	4M17F9W
HSUPA 1900	4M15F9W

LTE Band 2 BW(MHz)	Emission Designator (99%OBW)QPSK	Emission Designator (99%OBW)16QAM
1.4	1M10G7D	1M11W7D
3	2M72G7D	2M72W7D
5	4M52G7D	4M53W7D
10	9M01G7D	9M00W7D
15	13M5G7D	13M6W7D
20	18M1G7D	18M1W7D
LTE Band 4 BW(MHz)	Emission Designator (99%OBW)QPSK	Emission Designator (99%OBW)16QAM
1.4	1M10G7D	1M11W7D
3	2M72G7D	2M72W7D
5	4M52G7D	4M54W7D
10	8M99G7D	8M99W7D
15	13M5G7D	13M47W7D
20	18M1G7D	18M0W7D
LTE Band 5 BW(MHz)	Emission Designator (99%OBW)QPSK	Emission Designator (99%OBW)16QAM
1.4	1M10G7D	1M10W7D
3	2M72G7D	2M71W7D
5	4M53G7D	4M51W7D
10	9M00G7D	8M98W7D
LTE Band 7 BW(MHz)	Emission Designator (99%OBW)QPSK	Emission Designator (99%OBW)16QAM
5	4M52G7D	4M53W7D
10	9M01G7D	9M01W7D
15	13M5G7D	13M5W7D
20	18M1G7D	18M0W7D
LTE Band 12 BW(MHz)	Emission Designator (99%OBW)QPSK	Emission Designator (99%OBW)16QAM
1.4	1M10G7D	1M11W7D
3	2M72G7D	2M71W7D
5	4M53G7D	4M52W7D
10	9M02G7D	9M02W7D



LTE Band 17	Emission Designator	Emission Designator
BW(MHz)	(99%OBW)QPSK	(99%OBW)16QAM
5	4M53G7D	4M52W7D
10	9M00G7D	8M97W7D
LTE Band 25	Emission Designator	Emission Designator
BW(MHz)	(99%OBW)QPSK	(99%OBW)16QAM
1.4	1M10G7D	1M11W7D
3	2M72G7D	2M73W7D
5	4M54G7D	4M53W7D
10	9M00G7D	9M01W7D
15	13M48G7D	13M5W7D
20	18M0G7D	18M0W7D
LTE Band 26	Emission Designator	Emission Designator
BW(MHz)	(99%OBW)QPSK	(99%OBW)16QAM
1.4	1M11G7D	1M11W7D
3	2M72G7D	2M71W7D
5	4M52G7D	4M54W7D
10	9M01G7D	8M99W7D
15	13M5G7D	13M5W7D
LTE Band 26	Emission Designator	Emission Designator
BW(MHz)	(99%OBW)QPSK	(99%OBW)16QAM
1.4	1M10G7D	1M11W7D
3	2M72G7D	2M73W7D
5	4M52G7D	4M52W7D
10	8M98G7D	9M01W7D



3 TEST CONFIGURATION OF EQUIPMENT UNDER TEST

Antenna port conducted and radiated test items were performed according to KDB 971168 D01 and ANSI C63.26 2015 Power Meas. License Digital Systems with maximum output power.

Radiated measurements were performed with rotating EUT in different three orthogonal test planes to find the maximum emission.

Radiated emissions were investigated as following frequency range:

1. 30 MHz to 10th harmonic for GSM850 and WCDMA Band V.
2. 30 MHz to 10th harmonic for WCDMA Band IV.
3. 30 MHz to 10th harmonic for GSM1900 and WCDMA Band II.

All modes and data rates and positions were investigated.

Test modes are chosen to be reported as the worst case configuration below:

BAND	TEST MODES	
	RADIATED TCS	CONDUCTED TCS
GSM 850	GSM LINK GPRS/EDGE CLASS 12 LINK	GSM LINK GPRS/EDGE CLASS 12 LINK
GSM 1900	GSM LINK GPRS/EDGE CLASS 12 LINK	GSM LINK GPRS/EDGE CLASS 12 LINK
WCDMA BAND V	RMC 12.2KBPS LINK	RMC 12.2KBPS LINK
WCDMA BAND II	RMC 12.2KBPS LINK	RMC 12.2KBPS LINK



LTE:

ITEMS	Band	Bandwidth (MHz)						Modulation		RB #			Test Channel		
		1.4	3	5	10	15	20	QPSK	16QAM	1	Half	Full	L	M	H
Max. Output Power	2	v	v	v	v	v	v	v	v	v	v	v	v	v	v
	4	v	v	v	v	v	v	v	v	v	v	v	v	v	v
	5	v	v	v	v			v	v	v	v	v	v	v	v
	7			v	v	v	v	v	v	v	v	v	v	v	v
	12	v	v	v	v			v	v	v	v	v	v	v	v
	17			v	v			v	v	v	v	v	v	v	v
	25	v	v	v	v	v	v	v	v	v	v	v	v	v	v
	26	v	v	v	v	v		v	v	v	v	v	v	v	v
Peak&Avera Ratio	2	v	v	v	v	v	v	v	v	v			v	v	v
	4	v	v	v	v	v	v	v	v	v			v	v	v
	5	v	v	v	v			v	v	v			v	v	v
	7			v	v	v	v	v	v	v			v	v	v
	12	v	v	v	v			v	v	v			v	v	v
	17			v	v			v	v	v			v	v	v
	25	v	v	v	v	v	v	v	v	v			v	v	v
	26	v	v	v	v	v		v	v	v			v	v	v
26dB&99% Bandwidth	2	v	v	v	v	v	v	v	v			v	v	v	v
	4	v	v	v	v	v	v	v	v			v	v	v	v
	5	v	v	v	v			v	v			v	v	v	v
	7			v	v	v	v	v	v			v	v	v	v
	12	v	v	v	v			v	v			v	v	v	v
	17			v	v			v	v			v	v	v	v
	25	v	v	v	v	v	v	v	v			v	v	v	v
	26	v	v	v	v	v		v	v			v	v	v	v
Conducted Band Edge	2	v	v	v	v	v	v	v	v			v	v		v
	4	v	v	v	v	v	v	v	v			v	v		v
	5	v	v	v	v			v	v			v	v		v
	7			v	v	v	v	v	v			v	v		v
	12	v	v	v	v			v	v			v	v		v
	17			v	v			v	v			v	v		v
	25	v	v	v	v	v	v	v	v			v	v		v
	26	v	v	v	v	v		v	v			v	v		v
Conducted Spurious Emission	2	v	v	v	v	v	v	v	v	v		v	v	v	v
	4	v	v	v	v	v	v	v	v	v		v	v	v	v
	5	v	v	v	v			v	v	v		v	v	v	v
	7			v	v	v	v	v	v	v		v	v	v	v
	12	v	v	v	v			v	v	v		v	v	v	v
	17			v	v			v	v	v		v	v	v	v
	25	v	v	v	v	v	v	v	v	v		v	v	v	v



	26	v	v	v	v	v		v	v	v		v	v	v	v
Frequency Stability	2				v			v				v		v	
	4				v			v				v		v	
	5				v			v				v		v	
	7				v			v				v		v	
	12				v			v				v		v	
	17				v			v				v		v	
	25				v			v				v		v	
	26				v			v				v		v	
E.R.P.& E.I.R.P.	2	v	v	v	v	v	v	v	v	v	v	v	v	v	v
	4	v	v	v	v	v	v	v	v	v	v	v	v	v	v
	5	v	v	v	v			v	v	v	v	v	v	v	v
	7			v	v	v	v	v	v	v	v	v	v	v	v
	12	v	v	v	v			v	v	v	v	v	v	v	v
	17			v	v			v	v	v	v	v	v	v	v
	25	v	v	v	v	v	v	v	v	v	v	v	v	v	v
	26	v	v	v	v	v		v	v	v	v	v	v	v	v
Radiated Spurious Emission	2	v	v	v	v	v	v	v		v			v	v	v
	4	v	v	v	v	v	v	v		v			v	v	v
	5	v	v	v	v			v		v			v	v	v
	7			v	v	v	v	v		v			v	v	v
	12	v	v	v	v			v		v			v	v	v
	17			v	v			v		v			v	v	v
	25	v	v	v	v	v	v	v		v			v	v	v
	26	v	v	v	v	v		v		v			v	v	v



4 MEASUREMENT INSTRUMENTS

RF Radiation Test Equipment					
Kind of Equipment	Manufacturer	Type No.	Serial No.	Last Calibration	Calibrated Until
Temperature & Humidity	SW-108	SuWei	N/A	2023.03.03	2024.03.02
Wireless Communications Test Set	R&S	CMW 500	117239	2023.03.01	2024.02.29
Pre-Amplifier(0.1M-3GHz)	EM	EM330	060665	2023.02.28	2024.02.27
Pre-Amplifier (1G-18GHz)	SKET	LNPA-01018G-45	SK2018080901	2023.09.28	2024.09.27
Positioning Controller	MF	MF-7802	MF-780208587	N/A	N/A
Signal Analyzer	R&S	FSV 40-N	101823	2023.09.26	2024.09.25
Switch Control Box	N/A	N/A	N/A	N/A	N/A
Filter Box	BALUN Technology	SU319E	BL-SZ1530051	N/A	N/A
Video Controller	SKET	FCS C-3	N/A	N/A	N/A
Bilog Antenna	TESEQ	CBL6111D	34678	2022.09.30	2024.09.29
Horn Antenna	SCHWARZBECK	BBHA 9120D	02014	2023.09.24	2025.09.23
Antenna Mast	MF	MFA-440H	N/A	N/A	N/A
Turn Table	MF	N/A	N/A	N/A	N/A
AC Power Source	APC	KDF-11010G	F214050035	N/A	N/A
DC Power Supply	Zhaoxin	RXN 605D	20R605D11010081	N/A	N/A
Test SW	EMC Test Software	15.2.0.339			
	EZ-EMC	Ver.STSLAB-03A1 RE			
RF Connected Test Equipment					
Kind of Equipment	Manufacturer	Type No.	Serial No.	Last Calibration	Calibrated Until
Temperature & Humidity	SW-108	SuWei	N/A	2023.03.03	2024.03.02
Wireless Communications Test Set	R&S	CMW 500	131428	2023.03.01	2024.02.29
Signal Analyzer	Agilent	N9020A	MY52440124	2023.03.01	2024.02.29
RF Automatic Test System	Maiwei	MW200-SFCB	N/A	N/A	N/A
Temperature & Humidity Test Chamber	Safety test	AG80L	171200018	2023.03.01	2024.02.29
Programmable Power Supply	Agilent	E3642A	MY40002025	2023.09.26	2024.09.25
Test SW	MTS 8200	2.0.0.0			

5 TEST ITEMS

5.1 CONDUCTED OUTPUT POWER&TRANSMITTER RADIATED POWER

TEST OVERVIEW

CONDUCTED OUTPUT POWER:

A system simulator was used to establish communication with the EUT. Its parameters were set to enforce EUT transmitting at the maximum power. The measured power in the radio frequency on the transmitter output terminals shall be reported.

TRANSMITTER RADIATED POWER (EIRP/ERP)

Determining ERP and/or EIRP from conducted RF output power measurements according to ANSI C63.26 2015 Section 5.2.5.5.

In many cases, RF output power limits are specified in terms of the ERP or the EIRP. Typically, ERP is specified when the operating frequency is less than or equal to 1 GHz and EIRP is specified when the operating frequency is greater than 1 GHz. Both are defined as the product of the power supplied to the antenna and its gain (relative to a dipole antenna in the case of ERP, and relative to an isotropic antenna in the case of EIRP); however, when working in decibels (i.e., logarithmic scale), the ERP and EIRP represent the sum of the transmit antenna gain (in dBd or dBi, respectively) and the conducted RF output power (expressed in dB relative to watts or milliwatts).

The relevant equation for determining the maximum ERP or EIRP from the measured RF output power is given in Equation (1) as follows:

$$(1) \text{ ERP or EIRP} = \text{PMeas} + \text{GT}$$

$$\text{ERP} = \text{EIRP} - 2.15$$

where

ERP or EIRP effective radiated power or equivalent isotropically radiated power, respectively (expressed in the same units as PMeas, e.g., dBm or dBW)

PMeas measured transmitter output power or PSD, in dBm or dBW

GT gain of the transmitting antenna, in dBd (ERP) or dBi (EIRP)

For devices utilizing multiple antennas, see 6.4 for guidance with respect to determining the effective array transmit antenna gain term to be used in the above equation.

The following equations demonstrate the mathematical relationship between ERP and EIRP:

a) $\text{ERP} = \text{EIRP} - 2.15$, where ERP and EIRP are expressed in consistent units.

b) $\text{EIRP} = \text{ERP} + 2.15$, where ERP and EIRP are expressed in consistent units.

TEST PROCEDURES

1. The transmitter output port was connected to the system simulator.
2. Set eut at maximum power through the system simulator.
3. Select lowest, middle, and highest channels for each band and different modulation.
4. Measure and record the power level from the system simulator.

TEST SETUP

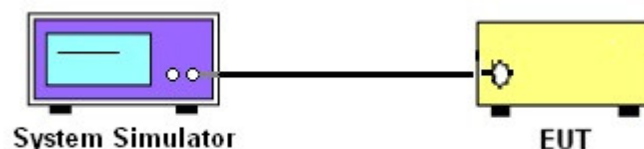

TEST RESULT

GSM 850							
Mode	Frequency (MHz)	Conduction AVG Power(dBm)	Ant Gain (dBi)	ERP (dBm)	ERP Limit (W)	ERP Limit (dBm)	Conclusion
GPRS (GMSK,1-Slot)	824.2	33.58	-1.15	30.28	7.00	38.45	PASS
	836.6	33.69	-1.15	30.39	7.00	38.45	PASS
	848.8	33.52	-1.15	30.22	7.00	38.45	PASS
GPRS (GMSK,2-Slot)	824.2	31.05	-1.15	27.75	7.00	38.45	PASS
	836.6	31.11	-1.15	27.81	7.00	38.45	PASS
	848.8	31.05	-1.15	27.75	7.00	38.45	PASS
GPRS (GMSK,3-Slot)	824.2	28.66	-1.15	25.36	7.00	38.45	PASS
	836.6	28.76	-1.15	25.46	7.00	38.45	PASS
	848.8	28.67	-1.15	25.37	7.00	38.45	PASS
GPRS (GMSK,4-Slot)	824.2	26.49	-1.15	23.19	7.00	38.45	PASS
	836.6	26.55	-1.15	23.25	7.00	38.45	PASS
	848.8	26.46	-1.15	23.16	7.00	38.45	PASS
EGPRS (8PSK,1-Slot)	824.2	26.28	-1.15	22.98	7.00	38.45	PASS
	836.6	26.94	-1.15	23.64	7.00	38.45	PASS
	848.8	26.50	-1.15	23.20	7.00	38.45	PASS
EGPRS (8PSK,2-Slot)	824.2	26.03	-1.15	22.73	7.00	38.45	PASS
	836.6	25.49	-1.15	22.19	7.00	38.45	PASS
	848.8	25.61	-1.15	22.31	7.00	38.45	PASS
EGPRS (8PSK,3-Slot)	824.2	23.14	-1.15	19.84	7.00	38.45	PASS
	836.6	22.92	-1.15	19.62	7.00	38.45	PASS
	848.8	22.35	-1.15	19.05	7.00	38.45	PASS
EGPRS (8PSK,4-Slot)	824.2	20.84	-1.15	17.54	7.00	38.45	PASS
	836.6	20.14	-1.15	16.84	7.00	38.45	PASS
	848.8	19.87	-1.15	16.57	7.00	38.45	PASS



PCS 1900							
Mode	Frequency (MHz)	Conduction AVG Power(dBm)	Ant Gain (dBi)	EIRP (dBm)	EIRP Limit (W)	EIRP Limit (dBm)	Conclusion
GPRS (GMSK,1-Slot)	1850.2	30.01	1.48	31.49	2.00	33.01	PASS
	1880.0	29.98	1.48	31.46	2.00	33.01	PASS
	1909.8	29.80	1.48	31.28	2.00	33.01	PASS
GPRS (GMSK,2-Slot)	1850.2	27.47	1.48	28.95	2.00	33.01	PASS
	1880.0	27.35	1.48	28.83	2.00	33.01	PASS
	1909.8	27.02	1.48	28.50	2.00	33.01	PASS
GPRS (GMSK,3-Slot)	1850.2	25.73	1.48	27.21	2.00	33.01	PASS
	1880.0	25.61	1.48	27.09	2.00	33.01	PASS
	1909.8	25.25	1.48	26.73	2.00	33.01	PASS
GPRS (GMSK,4-Slot)	1850.2	23.53	1.48	25.01	2.00	33.01	PASS
	1880.0	23.52	1.48	25.00	2.00	33.01	PASS
	1909.8	23.15	1.48	24.63	2.00	33.01	PASS
EGPRS (8PSK,1-Slot)	1850.2	25.40	1.48	26.88	2.00	33.01	PASS
	1880.0	26.15	1.48	27.63	2.00	33.01	PASS
	1909.8	25.24	1.48	26.72	2.00	33.01	PASS
EGPRS (8PSK,2-Slot)	1850.2	23.15	1.48	24.63	2.00	33.01	PASS
	1880.0	24.64	1.48	26.12	2.00	33.01	PASS
	1909.8	23.41	1.48	24.89	2.00	33.01	PASS
EGPRS (8PSK,3-Slot)	1850.2	20.59	1.48	22.07	2.00	33.01	PASS
	1880.0	21.52	1.48	23.00	2.00	33.01	PASS
	1909.8	20.71	1.48	22.19	2.00	33.01	PASS
EGPRS (8PSK,4-Slot)	1850.2	18.90	1.48	20.38	2.00	33.01	PASS
	1880.0	20.31	1.48	21.79	2.00	33.01	PASS
	1909.8	19.00	1.48	20.48	2.00	33.01	PASS



Radiated Power (EIRP) for WCDMA Band 2							
Mode	Frequency (MHz)	Conduction AVG Power(dBm)	Ant Gain (dBi)	EIRP (dBm)	EIRP Limit(W)	EIRP Limit (dBm)	Conclusion
WCDMA	1852.40	22.76	1.48	24.24	2.00	33.01	PASS
	1880.00	22.66	1.48	24.14	2.00	33.01	PASS
	1907.60	22.54	1.48	24.02	2.00	33.01	PASS
HSDPA Subtest 1	1852.40	23.07	1.48	24.55	2.00	33.01	PASS
	1880.00	22.27	1.48	23.75	2.00	33.01	PASS
	1907.60	22.01	1.48	23.49	2.00	33.01	PASS
HSDPA Subtest 2	1852.40	21.73	1.48	23.21	2.00	33.01	PASS
	1880.00	22.48	1.48	23.96	2.00	33.01	PASS
	1907.60	22.32	1.48	23.80	2.00	33.01	PASS
HSDPA Subtest 3	1852.40	22.10	1.48	23.58	2.00	33.01	PASS
	1880.00	22.26	1.48	23.74	2.00	33.01	PASS
	1907.60	22.52	1.48	24.00	2.00	33.01	PASS
HSDPA Subtest 4	1852.40	22.13	1.48	23.61	2.00	33.01	PASS
	1880.00	22.04	1.48	23.52	2.00	33.01	PASS
	1907.60	21.80	1.48	23.28	2.00	33.01	PASS
HSUPA Subtest 1	1852.40	23.14	1.48	24.62	2.00	33.01	PASS
	1880.00	22.69	1.48	24.17	2.00	33.01	PASS
	1907.60	21.89	1.48	23.37	2.00	33.01	PASS
HSUPA Subtest 2	1852.40	22.60	1.48	24.08	2.00	33.01	PASS
	1880.00	22.10	1.48	23.58	2.00	33.01	PASS
	1907.60	22.48	1.48	23.96	2.00	33.01	PASS
HSUPA Subtest 3	1852.40	22.51	1.48	23.99	2.00	33.01	PASS
	1880.00	22.29	1.48	23.77	2.00	33.01	PASS
	1907.60	22.50	1.48	23.98	2.00	33.01	PASS
HSUPA Subtest 4	1852.40	22.25	1.48	23.73	2.00	33.01	PASS
	1880.00	22.53	1.48	24.01	2.00	33.01	PASS
	1907.60	22.61	1.48	24.09	2.00	33.01	PASS
HSUPA Subtest 5	1852.40	22.17	1.48	23.65	2.00	33.01	PASS
	1880.00	22.53	1.48	24.01	2.00	33.01	PASS
	1907.60	22.26	1.48	23.74	2.00	33.01	PASS



Radiated Power (ERP) for WCDMA Band 5							
Mode	Frequency (MHz)	Conduction AVG Power(dBm)	Ant Gain (dBi)	ERP (dBm)	ERP Limit(W)	ERP Limit (dBm)	Conclusion
WCDMA	826.40	22.81	-1.15	19.51	7.00	38.45	PASS
	836.40	22.90	-1.15	19.60	7.00	38.45	PASS
	846.60	22.98	-1.15	19.68	7.00	38.45	PASS
HSDPA Subtest 1	826.40	22.97	-1.15	19.67	7.00	38.45	PASS
	836.40	22.63	-1.15	19.33	7.00	38.45	PASS
	846.60	22.41	-1.15	19.11	7.00	38.45	PASS
HSDPA Subtest 2	826.40	22.32	-1.15	19.02	7.00	38.45	PASS
	836.40	23.02	-1.15	19.72	7.00	38.45	PASS
	846.60	22.73	-1.15	19.43	7.00	38.45	PASS
HSDPA Subtest 3	826.40	22.31	-1.15	19.01	7.00	38.45	PASS
	836.40	22.43	-1.15	19.13	7.00	38.45	PASS
	846.60	22.76	-1.15	19.46	7.00	38.45	PASS
HSDPA Subtest 4	826.40	22.41	-1.15	19.11	7.00	38.45	PASS
	836.40	22.27	-1.15	18.97	7.00	38.45	PASS
	846.60	22.12	-1.15	18.82	7.00	38.45	PASS
HSUPA Subtest 1	826.40	23.05	-1.15	19.75	7.00	38.45	PASS
	836.40	22.99	-1.15	19.69	7.00	38.45	PASS
	846.60	22.71	-1.15	19.41	7.00	38.45	PASS
HSUPA Subtest 2	826.40	23.03	-1.15	19.73	7.00	38.45	PASS
	836.40	22.63	-1.15	19.33	7.00	38.45	PASS
	846.60	23.04	-1.15	19.74	7.00	38.45	PASS
HSUPA Subtest 3	826.40	23.09	-1.15	19.79	7.00	38.45	PASS
	836.40	22.66	-1.15	19.36	7.00	38.45	PASS
	846.60	23.09	-1.15	19.79	7.00	38.45	PASS
HSUPA Subtest 4	826.40	22.95	-1.15	19.65	7.00	38.45	PASS
	836.40	22.41	-1.15	19.11	7.00	38.45	PASS
	846.60	22.58	-1.15	19.28	7.00	38.45	PASS
HSUPA Subtest 5	826.40	22.24	-1.15	18.94	7.00	38.45	PASS
	836.40	22.67	-1.15	19.37	7.00	38.45	PASS
	846.60	22.53	-1.15	19.23	7.00	38.45	PASS



Radiated Power (EIRP) for LTE Band 2 /1.4M											
BW (MHz)	UL Channel	RB Size	RB offset	Modulation	Conduction AVG Power(dBm)	Ant Gain (dBi)	EIRP (dBm)	EIRP Limit(W)	EIRP Limit(dBm)	Verdict	
1.4	Lowest	1	0	QPSK	23.62	1.48	25.10	2.00	33.01	PASS	
		1	2		23.62	1.48	25.10	2.00	33.01	PASS	
		1	5		23.55	1.48	25.03	2.00	33.01	PASS	
		3	0		23.29	1.48	24.77	2.00	33.01	PASS	
		3	1		23.34	1.48	24.82	2.00	33.01	PASS	
		3	2		23.28	1.48	24.76	2.00	33.01	PASS	
		6	0	22.30	1.48	23.78	2.00	33.01	PASS		
		1	0	16QAM	23.00	1.48	24.48	2.00	33.01	PASS	
		1	2		23.11	1.48	24.59	2.00	33.01	PASS	
		1	5		23.01	1.48	24.49	2.00	33.01	PASS	
		3	0		22.26	1.48	23.74	2.00	33.01	PASS	
		3	1		22.33	1.48	23.81	2.00	33.01	PASS	
		3	2		22.29	1.48	23.77	2.00	33.01	PASS	
		6	0	21.34	1.48	22.82	2.00	33.01	PASS		
		Middle	QPSK	1	0	23.17	1.48	24.65	2.00	33.01	PASS
				1	2	23.24	1.48	24.72	2.00	33.01	PASS
				1	5	23.24	1.48	24.72	2.00	33.01	PASS
				3	0	23.22	1.48	24.70	2.00	33.01	PASS
	3			1	23.30	1.48	24.78	2.00	33.01	PASS	
	3			2	23.29	1.48	24.77	2.00	33.01	PASS	
	6		0	22.13	1.48	23.61	2.00	33.01	PASS		
	16QAM		1	0	22.21	1.48	23.69	2.00	33.01	PASS	
			1	2	22.26	1.48	23.74	2.00	33.01	PASS	
			1	5	22.25	1.48	23.73	2.00	33.01	PASS	
			3	0	22.34	1.48	23.82	2.00	33.01	PASS	
			3	1	22.31	1.48	23.79	2.00	33.01	PASS	
			3	2	22.29	1.48	23.77	2.00	33.01	PASS	
	6		0	21.35	1.48	22.83	2.00	33.01	PASS		
	Highest		QPSK	1	0	23.29	1.48	24.77	2.00	33.01	PASS
				1	2	23.26	1.48	24.74	2.00	33.01	PASS
				1	5	23.22	1.48	24.70	2.00	33.01	PASS
				3	0	23.15	1.48	24.63	2.00	33.01	PASS
		3		1	23.15	1.48	24.63	2.00	33.01	PASS	
		3		2	23.23	1.48	24.71	2.00	33.01	PASS	
		6	0	22.17	1.48	23.65	2.00	33.01	PASS		
		16QAM	1	0	22.37	1.48	23.85	2.00	33.01	PASS	
			1	2	22.41	1.48	23.89	2.00	33.01	PASS	
			1	5	22.37	1.48	23.85	2.00	33.01	PASS	
			3	0	22.29	1.48	23.77	2.00	33.01	PASS	
			3	1	22.29	1.48	23.77	2.00	33.01	PASS	
			3	2	22.30	1.48	23.78	2.00	33.01	PASS	
			6	0	21.30	1.48	22.78	2.00	33.01	PASS	



Radiated Power (EIRP) for LTE Band 2 /3M										
BW (MHz)	UL Channel	RB Size	RB offset	Modulation	Conduction AVG Power(dBm)	Ant Gain (dBi)	EIRP (dBm)	EIRP Limit(W)	EIRP Limit(dBm)	Verdict
3	Lowest	1	0	QPSK	23.50	1.48	24.98	2.00	33.01	PASS
		1	7		23.53	1.48	25.01	2.00	33.01	PASS
		1	14		23.52	1.48	25.00	2.00	33.01	PASS
		8	0		22.22	1.48	23.70	2.00	33.01	PASS
		8	4		22.27	1.48	23.75	2.00	33.01	PASS
		8	7		22.25	1.48	23.73	2.00	33.01	PASS
		15	0	22.24	1.48	23.72	2.00	33.01	PASS	
		1	0	22.05	1.48	23.53	2.00	33.01	PASS	
		1	7	22.01	1.48	23.49	2.00	33.01	PASS	
		1	14	22.04	1.48	23.52	2.00	33.01	PASS	
		8	0	21.43	1.48	22.91	2.00	33.01	PASS	
		8	4	21.50	1.48	22.98	2.00	33.01	PASS	
		8	7	21.49	1.48	22.97	2.00	33.01	PASS	
		15	0	21.27	1.48	22.75	2.00	33.01	PASS	
		1	0	23.26	1.48	24.74	2.00	33.01	PASS	
	1	7	23.30	1.48	24.78	2.00	33.01	PASS		
	1	14	23.23	1.48	24.71	2.00	33.01	PASS		
	8	0	22.31	1.48	23.79	2.00	33.01	PASS		
	8	4	22.33	1.48	23.81	2.00	33.01	PASS		
	8	7	22.18	1.48	23.66	2.00	33.01	PASS		
	15	0	22.13	1.48	23.61	2.00	33.01	PASS		
	1	0	22.24	1.48	23.72	2.00	33.01	PASS		
	1	7	22.21	1.48	23.69	2.00	33.01	PASS		
	1	14	22.26	1.48	23.74	2.00	33.01	PASS		
	8	0	21.26	1.48	22.74	2.00	33.01	PASS		
	8	4	21.26	1.48	22.74	2.00	33.01	PASS		
	8	7	21.32	1.48	22.80	2.00	33.01	PASS		
	15	0	21.23	1.48	22.71	2.00	33.01	PASS		
	1	0	23.40	1.48	24.88	2.00	33.01	PASS		
	1	7	23.32	1.48	24.80	2.00	33.01	PASS		
	1	14	23.28	1.48	24.76	2.00	33.01	PASS		
	8	0	22.24	1.48	23.72	2.00	33.01	PASS		
	8	4	22.27	1.48	23.75	2.00	33.01	PASS		
	8	7	22.14	1.48	23.62	2.00	33.01	PASS		
	15	0	22.23	1.48	23.71	2.00	33.01	PASS		
	1	0	22.51	1.48	23.99	2.00	33.01	PASS		
1	7	22.51	1.48	23.99	2.00	33.01	PASS			
1	14	22.39	1.48	23.87	2.00	33.01	PASS			
8	0	21.23	1.48	22.71	2.00	33.01	PASS			
8	4	21.24	1.48	22.72	2.00	33.01	PASS			
8	7	21.24	1.48	22.72	2.00	33.01	PASS			
15	0	21.24	1.48	22.72	2.00	33.01	PASS			



Radiated Power (EIRP) for LTE Band 2 /5M										
BW (MHz)	UL Channel	RB Size	RB offset	Modulation	Conduction AVG Power(dBm)	Ant Gain (dBi)	EIRP (dBm)	EIRP Limit(W)	EIRP Limit(dBm)	Verdict
5	Lowest	1	0	QPSK	23.20	1.48	24.68	2.00	33.01	PASS
		1	12		23.13	1.48	24.61	2.00	33.01	PASS
		1	24		23.23	1.48	24.71	2.00	33.01	PASS
		12	0		22.28	1.48	23.76	2.00	33.01	PASS
		12	6		22.31	1.48	23.79	2.00	33.01	PASS
		12	11		22.28	1.48	23.76	2.00	33.01	PASS
		25	0		22.30	1.48	23.78	2.00	33.01	PASS
		1	0	16QAM	22.66	1.48	24.14	2.00	33.01	PASS
		1	12		22.67	1.48	24.15	2.00	33.01	PASS
		1	24		22.67	1.48	24.15	2.00	33.01	PASS
		12	0		21.21	1.48	22.69	2.00	33.01	PASS
		12	6		21.26	1.48	22.74	2.00	33.01	PASS
		12	11		21.24	1.48	22.72	2.00	33.01	PASS
		25	0		21.49	1.48	22.97	2.00	33.01	PASS
	1	0	QPSK	23.48	1.48	24.96	2.00	33.01	PASS	
	1	12		23.45	1.48	24.93	2.00	33.01	PASS	
	1	24		23.47	1.48	24.95	2.00	33.01	PASS	
	12	0		22.23	1.48	23.71	2.00	33.01	PASS	
	12	6		22.21	1.48	23.69	2.00	33.01	PASS	
	12	11		22.20	1.48	23.68	2.00	33.01	PASS	
	25	0		22.26	1.48	23.74	2.00	33.01	PASS	
	1	0	16QAM	22.49	1.48	23.97	2.00	33.01	PASS	
	1	12		22.48	1.48	23.96	2.00	33.01	PASS	
	1	24		22.47	1.48	23.95	2.00	33.01	PASS	
	12	0		21.34	1.48	22.82	2.00	33.01	PASS	
	12	6		21.29	1.48	22.77	2.00	33.01	PASS	
	12	11		21.34	1.48	22.82	2.00	33.01	PASS	
	25	0		21.28	1.48	22.76	2.00	33.01	PASS	
	1	0	QPSK	23.32	1.48	24.80	2.00	33.01	PASS	
	1	12		23.20	1.48	24.68	2.00	33.01	PASS	
	1	24		23.19	1.48	24.67	2.00	33.01	PASS	
	12	0		22.31	1.48	23.79	2.00	33.01	PASS	
	12	6		22.28	1.48	23.76	2.00	33.01	PASS	
	12	11		22.26	1.48	23.74	2.00	33.01	PASS	
	25	0		22.22	1.48	23.70	2.00	33.01	PASS	
	1	0	16QAM	21.88	1.48	23.36	2.00	33.01	PASS	
	1	12		21.97	1.48	23.45	2.00	33.01	PASS	
	1	24		21.98	1.48	23.46	2.00	33.01	PASS	
	12	0		21.33	1.48	22.81	2.00	33.01	PASS	
	12	6		21.32	1.48	22.80	2.00	33.01	PASS	
	12	11		21.34	1.48	22.82	2.00	33.01	PASS	
	25	0		21.20	1.48	22.68	2.00	33.01	PASS	



Radiated Power (EIRP) for LTE Band 2 /10M										
BW (MHz)	UL Channel	RB Size	RB offset	Modulation	Conduction AVG Power(dBm)	Ant Gain (dBi)	EIRP (dBm)	EIRP Limit(W)	EIRP Limit(dBm)	Verdict
10	Lowest	1	0	QPSK	23.56	1.48	25.04	2.00	33.01	PASS
		1	24		23.54	1.48	25.02	2.00	33.01	PASS
		1	49		23.59	1.48	25.07	2.00	33.01	PASS
		25	0		22.35	1.48	23.83	2.00	33.01	PASS
		25	12		22.41	1.48	23.89	2.00	33.01	PASS
		25	24		22.41	1.48	23.89	2.00	33.01	PASS
		50	0	22.35	1.48	23.83	2.00	33.01	PASS	
		1	0	16QAM	22.13	1.48	23.61	2.00	33.01	PASS
		1	24		22.04	1.48	23.52	2.00	33.01	PASS
		1	49		22.16	1.48	23.64	2.00	33.01	PASS
		25	0		21.44	1.48	22.92	2.00	33.01	PASS
		25	12		21.50	1.48	22.98	2.00	33.01	PASS
		25	24		21.49	1.48	22.97	2.00	33.01	PASS
		50	0	21.42	1.48	22.90	2.00	33.01	PASS	
		1	0	QPSK	23.41	1.48	24.89	2.00	33.01	PASS
	1	24	23.35		1.48	24.83	2.00	33.01	PASS	
	1	49	23.35		1.48	24.83	2.00	33.01	PASS	
	25	0	22.25		1.48	23.73	2.00	33.01	PASS	
	25	12	22.23		1.48	23.71	2.00	33.01	PASS	
	25	24	22.32		1.48	23.80	2.00	33.01	PASS	
	50	0	22.18	1.48	23.66	2.00	33.01	PASS		
	1	0	16QAM	22.78	1.48	24.26	2.00	33.01	PASS	
	1	24		22.75	1.48	24.23	2.00	33.01	PASS	
	1	49		22.80	1.48	24.28	2.00	33.01	PASS	
	25	0		21.47	1.48	22.95	2.00	33.01	PASS	
	25	12		21.47	1.48	22.95	2.00	33.01	PASS	
	25	24		21.48	1.48	22.96	2.00	33.01	PASS	
	50	0	21.40	1.48	22.88	2.00	33.01	PASS		
	1	0	QPSK	23.48	1.48	24.96	2.00	33.01	PASS	
	1	24		23.38	1.48	24.86	2.00	33.01	PASS	
	1	49		23.26	1.48	24.74	2.00	33.01	PASS	
	25	0		22.37	1.48	23.85	2.00	33.01	PASS	
	25	12		22.29	1.48	23.77	2.00	33.01	PASS	
	25	24		22.34	1.48	23.82	2.00	33.01	PASS	
	50	0	22.27	1.48	23.75	2.00	33.01	PASS		
	1	0	16QAM	22.61	1.48	24.09	2.00	33.01	PASS	
1	24	22.53		1.48	24.01	2.00	33.01	PASS		
1	49	22.41		1.48	23.89	2.00	33.01	PASS		
25	0	21.47		1.48	22.95	2.00	33.01	PASS		
25	12	21.44		1.48	22.92	2.00	33.01	PASS		
25	24	21.45		1.48	22.93	2.00	33.01	PASS		
50	0	21.31	1.48	22.79	2.00	33.01	PASS			



Radiated Power (EIRP) for LTE Band 2 /15M										
BW (MHz)	UL Channel	RB Size	RB offset	Modulation	Conduction AVG Power(dBm)	Ant Gain (dBi)	EIRP (dBm)	EIRP Limit(W)	EIRP Limit(dBm)	Verdict
15	Lowest	1	0	QPSK	23.60	1.48	25.08	2.00	33.01	PASS
		1	37		23.57	1.48	25.05	2.00	33.01	PASS
		1	74		23.60	1.48	25.08	2.00	33.01	PASS
		36	0		22.28	1.48	23.76	2.00	33.01	PASS
		36	18		22.34	1.48	23.82	2.00	33.01	PASS
		36	39		22.35	1.48	23.83	2.00	33.01	PASS
		75	0	22.34	1.48	23.82	2.00	33.01	PASS	
		1	0	16QAM	22.14	1.48	23.62	2.00	33.01	PASS
		1	37		22.13	1.48	23.61	2.00	33.01	PASS
		1	74		22.19	1.48	23.67	2.00	33.01	PASS
		36	0		21.49	1.48	22.97	2.00	33.01	PASS
		36	18		21.50	1.48	22.98	2.00	33.01	PASS
		36	39		21.49	1.48	22.97	2.00	33.01	PASS
		75	0	21.47	1.48	22.95	2.00	33.01	PASS	
		1	0	QPSK	23.30	1.48	24.78	2.00	33.01	PASS
	1	37	23.20		1.48	24.68	2.00	33.01	PASS	
	1	74	23.25		1.48	24.73	2.00	33.01	PASS	
	36	0	22.36		1.48	23.84	2.00	33.01	PASS	
	36	18	22.35		1.48	23.83	2.00	33.01	PASS	
	36	39	22.21		1.48	23.69	2.00	33.01	PASS	
	75	0	22.31	1.48	23.79	2.00	33.01	PASS		
	1	0	16QAM	22.87	1.48	24.35	2.00	33.01	PASS	
	1	37		22.79	1.48	24.27	2.00	33.01	PASS	
	1	74		22.70	1.48	24.18	2.00	33.01	PASS	
	36	0		21.32	1.48	22.80	2.00	33.01	PASS	
	36	18		21.26	1.48	22.74	2.00	33.01	PASS	
	36	39		21.28	1.48	22.76	2.00	33.01	PASS	
	75	0	21.33	1.48	22.81	2.00	33.01	PASS		
	1	0	QPSK	23.62	1.48	25.10	2.00	33.01	PASS	
	1	37		23.59	1.48	25.07	2.00	33.01	PASS	
	1	74		23.41	1.48	24.89	2.00	33.01	PASS	
	36	0		22.36	1.48	23.84	2.00	33.01	PASS	
	36	18		22.37	1.48	23.85	2.00	33.01	PASS	
	36	39		22.21	1.48	23.69	2.00	33.01	PASS	
	75	0	22.33	1.48	23.81	2.00	33.01	PASS		
	1	0	16QAM	22.40	1.48	23.88	2.00	33.01	PASS	
1	37	22.30		1.48	23.78	2.00	33.01	PASS		
1	74	22.20		1.48	23.68	2.00	33.01	PASS		
36	0	21.50		1.48	22.98	2.00	33.01	PASS		
36	18	21.35		1.48	22.83	2.00	33.01	PASS		
36	39	21.33		1.48	22.81	2.00	33.01	PASS		
75	0	21.43	1.48	22.91	2.00	33.01	PASS			



Radiated Power (EIRP) for LTE Band 2 /20M										
BW (MHz)	UL Channel	RB Size	RB offset	Modulation	Conduction AVG Power(dBm)	Ant Gain (dBi)	EIRP (dBm)	EIRP Limit(W)	EIRP Limit(dBm)	Verdict
20	Lowest	1	0	QPSK	23.59	1.48	25.07	2.00	33.01	PASS
		1	49		23.60	1.48	25.08	2.00	33.01	PASS
		1	99		23.63	1.48	25.11	2.00	33.01	PASS
		50	0		22.41	1.48	23.89	2.00	33.01	PASS
		50	24		22.46	1.48	23.94	2.00	33.01	PASS
		50	49		22.48	1.48	23.96	2.00	33.01	PASS
		100	0	22.44	1.48	23.92	2.00	33.01	PASS	
		1	0	16QAM	22.55	1.48	24.03	2.00	33.01	PASS
		1	49		22.61	1.48	24.09	2.00	33.01	PASS
		1	99		22.59	1.48	24.07	2.00	33.01	PASS
		50	0		21.58	1.48	23.06	2.00	33.01	PASS
		50	24		21.54	1.48	23.02	2.00	33.01	PASS
		50	49		21.55	1.48	23.03	2.00	33.01	PASS
		100	0	21.49	1.48	22.97	2.00	33.01	PASS	
	1	0	QPSK	23.54	1.48	25.02	2.00	33.01	PASS	
	1	49		23.47	1.48	24.95	2.00	33.01	PASS	
	1	99		23.51	1.48	24.99	2.00	33.01	PASS	
	50	0		22.30	1.48	23.78	2.00	33.01	PASS	
	50	24		22.19	1.48	23.67	2.00	33.01	PASS	
	50	49		22.24	1.48	23.72	2.00	33.01	PASS	
	100	0	22.20	1.48	23.68	2.00	33.01	PASS		
	1	0	16QAM	22.76	1.48	24.24	2.00	33.01	PASS	
	1	49		22.68	1.48	24.16	2.00	33.01	PASS	
	1	99		22.71	1.48	24.19	2.00	33.01	PASS	
	50	0		21.44	1.48	22.92	2.00	33.01	PASS	
	50	24		21.35	1.48	22.83	2.00	33.01	PASS	
	50	49		21.31	1.48	22.79	2.00	33.01	PASS	
	100	0	21.30	1.48	22.78	2.00	33.01	PASS		
	1	0	QPSK	23.32	1.48	24.80	2.00	33.01	PASS	
	1	49		23.35	1.48	24.83	2.00	33.01	PASS	
	1	99		23.21	1.48	24.69	2.00	33.01	PASS	
	50	0		22.40	1.48	23.88	2.00	33.01	PASS	
	50	24		22.36	1.48	23.84	2.00	33.01	PASS	
	50	49		22.21	1.48	23.69	2.00	33.01	PASS	
	100	0	22.34	1.48	23.82	2.00	33.01	PASS		
	1	0	16QAM	22.40	1.48	23.88	2.00	33.01	PASS	
1	49	22.52		1.48	24.00	2.00	33.01	PASS		
1	99	22.30		1.48	23.78	2.00	33.01	PASS		
50	0	21.53		1.48	23.01	2.00	33.01	PASS		
50	24	21.53		1.48	23.01	2.00	33.01	PASS		
50	49	21.40		1.48	22.88	2.00	33.01	PASS		
100	0	21.48	1.48	22.96	2.00	33.01	PASS			



Radiated Power (EIRP) for LTE Band 4 /1.4M											
BW (MHz)	UL Channel	RB Size	RB offset	Modulation	Conduction AVG Power(dBm)	Ant Gain (dBi)	EIRP (dBm)	EIRP Limit(W)	EIRP Limit(dBm)	Verdict	
1.4	Lowest	1	0	QPSK	23.55	1.82	25.37	1.00	30.00	PASS	
		1	2		23.60	1.82	25.42	1.00	30.00	PASS	
		1	5		23.55	1.82	25.37	1.00	30.00	PASS	
		3	0		23.27	1.82	25.09	1.00	30.00	PASS	
		3	1		23.32	1.82	25.14	1.00	30.00	PASS	
		3	2		23.26	1.82	25.08	1.00	30.00	PASS	
		6	0	22.18	1.82	24.00	1.00	30.00	PASS		
		1	0	16QAM	23.13	1.82	24.95	1.00	30.00	PASS	
		1	2		23.13	1.82	24.95	1.00	30.00	PASS	
		1	5		23.13	1.82	24.95	1.00	30.00	PASS	
		3	0		22.21	1.82	24.03	1.00	30.00	PASS	
		3	1		22.20	1.82	24.02	1.00	30.00	PASS	
		3	2		22.24	1.82	24.06	1.00	30.00	PASS	
		6	0	21.34	1.82	23.16	1.00	30.00	PASS		
		Middle	QPSK	1	0	23.39	1.82	25.21	1.00	30.00	PASS
				1	2	23.42	1.82	25.24	1.00	30.00	PASS
				1	5	23.41	1.82	25.23	1.00	30.00	PASS
				3	0	23.39	1.82	25.21	1.00	30.00	PASS
	3			1	23.43	1.82	25.25	1.00	30.00	PASS	
	3			2	23.46	1.82	25.28	1.00	30.00	PASS	
	6		0	22.41	1.82	24.23	1.00	30.00	PASS		
	16QAM		1	0	23.18	1.82	25.00	1.00	30.00	PASS	
			1	2	23.15	1.82	24.97	1.00	30.00	PASS	
			1	5	23.13	1.82	24.95	1.00	30.00	PASS	
			3	0	22.47	1.82	24.29	1.00	30.00	PASS	
			3	1	22.46	1.82	24.28	1.00	30.00	PASS	
			3	2	22.44	1.82	24.26	1.00	30.00	PASS	
	6		0	21.65	1.82	23.47	1.00	30.00	PASS		
	Highest		QPSK	1	0	23.62	1.82	25.44	1.00	30.00	PASS
				1	2	23.63	1.82	25.45	1.00	30.00	PASS
				1	5	23.62	1.82	25.44	1.00	30.00	PASS
				3	0	23.60	1.82	25.42	1.00	30.00	PASS
		3		1	23.62	1.82	25.44	1.00	30.00	PASS	
		3		2	23.62	1.82	25.44	1.00	30.00	PASS	
		6	0	22.53	1.82	24.35	1.00	30.00	PASS		
		16QAM	1	0	22.83	1.82	24.65	1.00	30.00	PASS	
			1	2	22.78	1.82	24.60	1.00	30.00	PASS	
			1	5	22.81	1.82	24.63	1.00	30.00	PASS	
			3	0	22.53	1.82	24.35	1.00	30.00	PASS	
			3	1	22.48	1.82	24.30	1.00	30.00	PASS	
			3	2	22.49	1.82	24.31	1.00	30.00	PASS	
			6	0	21.53	1.82	23.35	1.00	30.00	PASS	



Radiated Power (EIRP) for LTE Band 4 /3M											
BW (MHz)	UL Channel	RB Size	RB offset	Modulation	Conduction AVG Power(dBm)	Ant Gain (dBi)	EIRP (dBm)	EIRP Limit(W)	EIRP Limit(dBm)	Verdict	
3	Lowest	1	0	QPSK	23.52	1.82	25.34	1.00	30.00	PASS	
		1	7		23.57	1.82	25.39	1.00	30.00	PASS	
		1	14		23.63	1.82	25.45	1.00	30.00	PASS	
		8	0		22.26	1.82	24.08	1.00	30.00	PASS	
		8	4		22.23	1.82	24.05	1.00	30.00	PASS	
		8	7		22.32	1.82	24.14	1.00	30.00	PASS	
		15	0	22.28	1.82	24.10	1.00	30.00	PASS		
		1	0	22.02	1.82	23.84	1.00	30.00	PASS		
		1	7	21.99	1.82	23.81	1.00	30.00	PASS		
		1	14	22.11	1.82	23.93	1.00	30.00	PASS		
		8	0	21.56	1.82	23.38	1.00	30.00	PASS		
		8	4	21.53	1.82	23.35	1.00	30.00	PASS		
		8	7	21.45	1.82	23.27	1.00	30.00	PASS		
		15	0	21.26	1.82	23.08	1.00	30.00	PASS		
		Middle	QPSK	1	0	23.54	1.82	25.36	1.00	30.00	PASS
	1			7	23.45	1.82	25.27	1.00	30.00	PASS	
	1			14	23.44	1.82	25.26	1.00	30.00	PASS	
	8			0	22.35	1.82	24.17	1.00	30.00	PASS	
	8			4	22.39	1.82	24.21	1.00	30.00	PASS	
	8			7	22.33	1.82	24.15	1.00	30.00	PASS	
	15		0	22.32	1.82	24.14	1.00	30.00	PASS		
	16QAM		1	0	23.20	1.82	25.02	1.00	30.00	PASS	
			1	7	23.11	1.82	24.93	1.00	30.00	PASS	
			1	14	23.15	1.82	24.97	1.00	30.00	PASS	
			8	0	21.44	1.82	23.26	1.00	30.00	PASS	
			8	4	21.44	1.82	23.26	1.00	30.00	PASS	
			8	7	21.45	1.82	23.27	1.00	30.00	PASS	
			15	0	21.61	1.82	23.43	1.00	30.00	PASS	
			Highest	QPSK	1	0	23.63	1.82	25.45	1.00	30.00
		1			7	23.63	1.82	25.45	1.00	30.00	PASS
	1	14			23.68	1.82	25.50	1.00	30.00	PASS	
	8	0			22.53	1.82	24.35	1.00	30.00	PASS	
	8	4			22.53	1.82	24.35	1.00	30.00	PASS	
	8	7			22.54	1.82	24.36	1.00	30.00	PASS	
	15	0		22.62	1.82	24.44	1.00	30.00	PASS		
	16QAM	1		0	22.77	1.82	24.59	1.00	30.00	PASS	
1		7		22.82	1.82	24.64	1.00	30.00	PASS		
1		14		22.88	1.82	24.70	1.00	30.00	PASS		
8		0		21.73	1.82	23.55	1.00	30.00	PASS		
8		4		21.73	1.82	23.55	1.00	30.00	PASS		
8		7		21.67	1.82	23.49	1.00	30.00	PASS		
15		0		21.66	1.82	23.48	1.00	30.00	PASS		



Radiated Power (EIRP) for LTE Band 4 /5M											
BW (MHz)	UL Channel	RB Size	RB offset	Modulation	Conduction AVG Power(dBm)	Ant Gain (dBi)	EIRP (dBm)	EIRP Limit(W)	EIRP Limit(dBm)	Verdict	
5	Lowest	1	0	QPSK	23.26	1.82	25.08	1.00	30.00	PASS	
		1	12		23.21	1.82	25.03	1.00	30.00	PASS	
		1	24		23.25	1.82	25.07	1.00	30.00	PASS	
		12	0		22.26	1.82	24.08	1.00	30.00	PASS	
		12	6		22.20	1.82	24.02	1.00	30.00	PASS	
		12	11		22.26	1.82	24.08	1.00	30.00	PASS	
		25	0	22.28	1.82	24.10	1.00	30.00	PASS		
		1	0	16QAM	22.22	1.82	24.04	1.00	30.00	PASS	
		1	12		22.30	1.82	24.12	1.00	30.00	PASS	
		1	24		22.27	1.82	24.09	1.00	30.00	PASS	
		12	0		21.27	1.82	23.09	1.00	30.00	PASS	
		12	6		21.29	1.82	23.11	1.00	30.00	PASS	
		12	11		21.28	1.82	23.10	1.00	30.00	PASS	
		25	0	21.48	1.82	23.30	1.00	30.00	PASS		
		Middle	QPSK	1	0	23.66	1.82	25.48	1.00	30.00	PASS
	1			12	23.59	1.82	25.41	1.00	30.00	PASS	
	1			24	23.63	1.82	25.45	1.00	30.00	PASS	
	12			0	22.52	1.82	24.34	1.00	30.00	PASS	
	12			6	22.46	1.82	24.28	1.00	30.00	PASS	
	12			11	22.55	1.82	24.37	1.00	30.00	PASS	
	25		0	22.46	1.82	24.28	1.00	30.00	PASS		
	16QAM		1	0	22.76	1.82	24.58	1.00	30.00	PASS	
			1	12	22.72	1.82	24.54	1.00	30.00	PASS	
			1	24	22.68	1.82	24.50	1.00	30.00	PASS	
			12	0	21.58	1.82	23.40	1.00	30.00	PASS	
			12	6	21.62	1.82	23.44	1.00	30.00	PASS	
			12	11	21.66	1.82	23.48	1.00	30.00	PASS	
			25	0	21.60	1.82	23.42	1.00	30.00	PASS	
			Highest	QPSK	1	0	23.40	1.82	25.22	1.00	30.00
		1			12	23.41	1.82	25.23	1.00	30.00	PASS
	1	24			23.52	1.82	25.34	1.00	30.00	PASS	
	12	0			22.43	1.82	24.25	1.00	30.00	PASS	
	12	6			22.50	1.82	24.32	1.00	30.00	PASS	
	12	11			22.61	1.82	24.43	1.00	30.00	PASS	
	25	0		22.52	1.82	24.34	1.00	30.00	PASS		
	16QAM	1		0	22.19	1.82	24.01	1.00	30.00	PASS	
		1		12	22.28	1.82	24.10	1.00	30.00	PASS	
		1		24	22.27	1.82	24.09	1.00	30.00	PASS	
		12		0	21.58	1.82	23.40	1.00	30.00	PASS	
		12		6	21.62	1.82	23.44	1.00	30.00	PASS	
		12		11	21.63	1.82	23.45	1.00	30.00	PASS	
		25		0	21.46	1.82	23.28	1.00	30.00	PASS	



Radiated Power (EIRP) for LTE Band 4 /10M										
BW (MHz)	UL Channel	RB Size	RB offset	Modulation	Conduction AVG Power(dBm)	Ant Gain (dBi)	EIRP (dBm)	EIRP Limit(W)	EIRP Limit(dBm)	Verdict
10	Lowest	1	0	QPSK	23.60	1.82	25.42	1.00	30.00	PASS
		1	24		23.70	1.82	25.52	1.00	30.00	PASS
		1	49		23.76	1.82	25.58	1.00	30.00	PASS
		25	0		22.36	1.82	24.18	1.00	30.00	PASS
		25	12		22.41	1.82	24.23	1.00	30.00	PASS
		25	24		22.48	1.82	24.30	1.00	30.00	PASS
		50	0	22.42	1.82	24.24	1.00	30.00	PASS	
		1	0	16QAM	22.04	1.82	23.86	1.00	30.00	PASS
		1	24		22.14	1.82	23.96	1.00	30.00	PASS
		1	49		22.26	1.82	24.08	1.00	30.00	PASS
		25	0		21.43	1.82	23.25	1.00	30.00	PASS
		25	12		21.52	1.82	23.34	1.00	30.00	PASS
		25	24		21.56	1.82	23.38	1.00	30.00	PASS
		50	0	21.51	1.82	23.33	1.00	30.00	PASS	
		1	0	QPSK	23.67	1.82	25.49	1.00	30.00	PASS
	1	24	23.50		1.82	25.32	1.00	30.00	PASS	
	1	49	23.47		1.82	25.29	1.00	30.00	PASS	
	25	0	22.59		1.82	24.41	1.00	30.00	PASS	
	25	12	22.59		1.82	24.41	1.00	30.00	PASS	
	25	24	22.41		1.82	24.23	1.00	30.00	PASS	
	50	0	22.47	1.82	24.29	1.00	30.00	PASS		
	1	0	16QAM	23.24	1.82	25.06	1.00	30.00	PASS	
	1	24		23.10	1.82	24.92	1.00	30.00	PASS	
	1	49		23.08	1.82	24.90	1.00	30.00	PASS	
	25	0		21.74	1.82	23.56	1.00	30.00	PASS	
	25	12		21.75	1.82	23.57	1.00	30.00	PASS	
	25	24		21.73	1.82	23.55	1.00	30.00	PASS	
	50	0	21.69	1.82	23.51	1.00	30.00	PASS		
	1	0	QPSK	23.53	1.82	25.35	1.00	30.00	PASS	
	1	24		23.53	1.82	25.35	1.00	30.00	PASS	
	1	49		23.64	1.82	25.46	1.00	30.00	PASS	
	25	0		22.54	1.82	24.36	1.00	30.00	PASS	
	25	12		22.58	1.82	24.40	1.00	30.00	PASS	
	25	24		22.58	1.82	24.40	1.00	30.00	PASS	
	50	0	22.58	1.82	24.40	1.00	30.00	PASS		
	1	0	16QAM	22.95	1.82	24.77	1.00	30.00	PASS	
	1	24		23.00	1.82	24.82	1.00	30.00	PASS	
	1	49		23.05	1.82	24.87	1.00	30.00	PASS	
	25	0		21.57	1.82	23.39	1.00	30.00	PASS	
	25	12		21.57	1.82	23.39	1.00	30.00	PASS	
	25	24		21.63	1.82	23.45	1.00	30.00	PASS	
	50	0	21.64	1.82	23.46	1.00	30.00	PASS		



Radiated Power (EIRP) for LTE Band 4 /15M										
BW (MHz)	UL Channel	RB Size	RB offset	Modulation	Conduction AVG Power(dBm)	Ant Gain (dBi)	EIRP (dBm)	EIRP Limit(W)	EIRP Limit(dBm)	Verdict
15	Lowest	1	0	QPSK	23.60	1.82	25.42	1.00	30.00	PASS
		1	37		23.81	1.82	25.63	1.00	30.00	PASS
		1	74		23.81	1.82	25.63	1.00	30.00	PASS
		36	0		22.43	1.82	24.25	1.00	30.00	PASS
		36	18		22.52	1.82	24.34	1.00	30.00	PASS
		36	39		22.53	1.82	24.35	1.00	30.00	PASS
		75	0		22.42	1.82	24.24	1.00	30.00	PASS
		1	0	16QAM	22.12	1.82	23.94	1.00	30.00	PASS
		1	37		22.26	1.82	24.08	1.00	30.00	PASS
		1	74		22.33	1.82	24.15	1.00	30.00	PASS
		36	0		21.60	1.82	23.42	1.00	30.00	PASS
		36	18		21.62	1.82	23.44	1.00	30.00	PASS
		36	39		21.66	1.82	23.48	1.00	30.00	PASS
		75	0		21.60	1.82	23.42	1.00	30.00	PASS
	Middle	QPSK	1	0	23.62	1.82	25.44	1.00	30.00	PASS
			1	37	23.52	1.82	25.34	1.00	30.00	PASS
			1	74	23.47	1.82	25.29	1.00	30.00	PASS
			36	0	22.61	1.82	24.43	1.00	30.00	PASS
			36	18	22.51	1.82	24.33	1.00	30.00	PASS
			36	39	22.56	1.82	24.38	1.00	30.00	PASS
			75	0	22.47	1.82	24.29	1.00	30.00	PASS
		16QAM	1	0	23.25	1.82	25.07	1.00	30.00	PASS
			1	37	23.09	1.82	24.91	1.00	30.00	PASS
			1	74	23.01	1.82	24.83	1.00	30.00	PASS
			36	0	21.72	1.82	23.54	1.00	30.00	PASS
			36	18	21.69	1.82	23.51	1.00	30.00	PASS
			36	39	21.59	1.82	23.41	1.00	30.00	PASS
			75	0	21.64	1.82	23.46	1.00	30.00	PASS
	Highest	QPSK	1	0	23.46	1.82	25.28	1.00	30.00	PASS
			1	37	23.52	1.82	25.34	1.00	30.00	PASS
			1	74	23.60	1.82	25.42	1.00	30.00	PASS
			36	0	22.40	1.82	24.22	1.00	30.00	PASS
			36	18	22.37	1.82	24.19	1.00	30.00	PASS
			36	39	22.43	1.82	24.25	1.00	30.00	PASS
			75	0	22.46	1.82	24.28	1.00	30.00	PASS
		16QAM	1	0	22.24	1.82	24.06	1.00	30.00	PASS
			1	37	22.25	1.82	24.07	1.00	30.00	PASS
			1	74	22.37	1.82	24.19	1.00	30.00	PASS
			36	0	21.43	1.82	23.25	1.00	30.00	PASS
			36	18	21.45	1.82	23.27	1.00	30.00	PASS
			36	39	21.59	1.82	23.41	1.00	30.00	PASS
			75	0	21.61	1.82	23.43	1.00	30.00	PASS



Radiated Power (EIRP) for LTE Band 4 /20M										
BW (MHz)	UL Channel	RB Size	RB offset	Modulation	Conduction AVG Power(dBm)	Ant Gain (dBi)	EIRP (dBm)	EIRP Limit(W)	EIRP Limit(dBm)	Verdict
20	Lowest	1	0	QPSK	23.63	1.82	25.45	1.00	30.00	PASS
		1	49		23.81	1.82	25.63	1.00	30.00	PASS
		1	99		23.83	1.82	25.65	1.00	30.00	PASS
		50	0		22.45	1.82	24.27	1.00	30.00	PASS
		50	24		22.67	1.82	24.49	1.00	30.00	PASS
		50	49		22.66	1.82	24.48	1.00	30.00	PASS
		100	0	22.53	1.82	24.35	1.00	30.00	PASS	
		1	0	16QAM	22.52	1.82	24.34	1.00	30.00	PASS
		1	49		22.66	1.82	24.48	1.00	30.00	PASS
		1	99		22.76	1.82	24.58	1.00	30.00	PASS
		50	0		21.58	1.82	23.40	1.00	30.00	PASS
		50	24		21.70	1.82	23.52	1.00	30.00	PASS
		50	49		21.74	1.82	23.56	1.00	30.00	PASS
		100	0	21.69	1.82	23.51	1.00	30.00	PASS	
		1	0	QPSK	23.87	1.82	25.69	1.00	30.00	PASS
		1	49		23.79	1.82	25.61	1.00	30.00	PASS
	1	99	23.68		1.82	25.50	1.00	30.00	PASS	
	50	0	22.66		1.82	24.48	1.00	30.00	PASS	
	50	24	22.53		1.82	24.35	1.00	30.00	PASS	
	50	49	22.48		1.82	24.30	1.00	30.00	PASS	
	100	0	22.54	1.82	24.36	1.00	30.00	PASS		
	1	0	16QAM	23.33	1.82	25.15	1.00	30.00	PASS	
	1	49		23.29	1.82	25.11	1.00	30.00	PASS	
	1	99		23.09	1.82	24.91	1.00	30.00	PASS	
	50	0		21.78	1.82	23.60	1.00	30.00	PASS	
	50	24		21.70	1.82	23.52	1.00	30.00	PASS	
	50	49		21.66	1.82	23.48	1.00	30.00	PASS	
	100	0	21.65	1.82	23.47	1.00	30.00	PASS		
	1	0	QPSK	23.56	1.82	25.38	1.00	30.00	PASS	
	1	49		23.52	1.82	25.34	1.00	30.00	PASS	
	1	99		23.60	1.82	25.42	1.00	30.00	PASS	
	50	0		22.48	1.82	24.30	1.00	30.00	PASS	
	50	24		22.54	1.82	24.36	1.00	30.00	PASS	
	50	49		22.62	1.82	24.44	1.00	30.00	PASS	
	100	0	22.52	1.82	24.34	1.00	30.00	PASS		
	1	0	16QAM	22.32	1.82	24.14	1.00	30.00	PASS	
	1	49		22.28	1.82	24.10	1.00	30.00	PASS	
	1	99		22.43	1.82	24.25	1.00	30.00	PASS	
	50	0		21.68	1.82	23.50	1.00	30.00	PASS	
	50	24		21.67	1.82	23.49	1.00	30.00	PASS	
	50	49		21.68	1.82	23.50	1.00	30.00	PASS	
	100	0	21.68	1.82	23.50	1.00	30.00	PASS		



Radiated Power (ERP) for LTE Band 5 /1.4M										
BW (MHz)	UL Channel	RB Size	RB offset	Modulation	Conduction AVG Power(dBm)	Ant Gain (dBi)	ERP (dBm)	ERP Limit(W)	ERP Limit(dBm)	Verdict
1.4	Lowest	1	0	QPSK	23.61	-1.15	20.31	7.00	38.45	PASS
		1	2		23.53	-1.15	20.23	7.00	38.45	PASS
		1	5		23.56	-1.15	20.26	7.00	38.45	PASS
		3	0		23.32	-1.15	20.02	7.00	38.45	PASS
		3	1		23.40	-1.15	20.10	7.00	38.45	PASS
		3	2		23.31	-1.15	20.01	7.00	38.45	PASS
		6	0	22.34	-1.15	19.04	7.00	38.45	PASS	
		1	0	16QAM	22.99	-1.15	19.69	7.00	38.45	PASS
		1	2		22.98	-1.15	19.68	7.00	38.45	PASS
		1	5		22.96	-1.15	19.66	7.00	38.45	PASS
		3	0		22.21	-1.15	18.91	7.00	38.45	PASS
		3	1		22.24	-1.15	18.94	7.00	38.45	PASS
	3	2	22.24		-1.15	18.94	7.00	38.45	PASS	
	6	0	21.15	-1.15	17.85	7.00	38.45	PASS		
	Middle	QPSK	1	0	23.55	-1.15	20.25	7.00	38.45	PASS
			1	2	23.44	-1.15	20.14	7.00	38.45	PASS
			1	5	23.45	-1.15	20.15	7.00	38.45	PASS
			3	0	23.50	-1.15	20.20	7.00	38.45	PASS
			3	1	23.55	-1.15	20.25	7.00	38.45	PASS
			3	2	23.58	-1.15	20.28	7.00	38.45	PASS
		6	0	22.57	-1.15	19.27	7.00	38.45	PASS	
		16QAM	1	0	23.30	-1.15	20.00	7.00	38.45	PASS
			1	2	23.25	-1.15	19.95	7.00	38.45	PASS
			1	5	23.23	-1.15	19.93	7.00	38.45	PASS
			3	0	22.56	-1.15	19.26	7.00	38.45	PASS
			3	1	22.56	-1.15	19.26	7.00	38.45	PASS
	3		2	22.53	-1.15	19.23	7.00	38.45	PASS	
	6	0	21.58	-1.15	18.28	7.00	38.45	PASS		
	Highest	QPSK	1	0	23.80	-1.15	20.50	7.00	38.45	PASS
			1	2	23.70	-1.15	20.40	7.00	38.45	PASS
			1	5	23.70	-1.15	20.40	7.00	38.45	PASS
			3	0	23.61	-1.15	20.31	7.00	38.45	PASS
			3	1	23.61	-1.15	20.31	7.00	38.45	PASS
			3	2	23.66	-1.15	20.36	7.00	38.45	PASS
		6	0	22.61	-1.15	19.31	7.00	38.45	PASS	
		16QAM	1	0	22.86	-1.15	19.56	7.00	38.45	PASS
1			2	22.97	-1.15	19.67	7.00	38.45	PASS	
1			5	22.94	-1.15	19.64	7.00	38.45	PASS	
3			0	22.60	-1.15	19.30	7.00	38.45	PASS	
3			1	22.69	-1.15	19.39	7.00	38.45	PASS	
3	2		22.71	-1.15	19.41	7.00	38.45	PASS		
6	0	21.75	-1.15	18.45	7.00	38.45	PASS			



Radiated Power (ERP) for LTE Band 5 /3M										
BW (MHz)	UL Channel	RB Size	RB offset	Modulation	Conduction AVG Power(dBm)	Ant Gain (dBi)	ERP (dBm)	ERP Limit(W)	ERP Limit(dBm)	Verdict
3	Lowest	1	0	QPSK	23.54	-1.15	20.24	7.00	38.45	PASS
		1	7		23.49	-1.15	20.19	7.00	38.45	PASS
		1	14		23.51	-1.15	20.21	7.00	38.45	PASS
		8	0		22.33	-1.15	19.03	7.00	38.45	PASS
		8	4		22.35	-1.15	19.05	7.00	38.45	PASS
		8	7		22.37	-1.15	19.07	7.00	38.45	PASS
		15	0		22.33	-1.15	19.03	7.00	38.45	PASS
		1	0	16QAM	22.12	-1.15	18.82	7.00	38.45	PASS
		1	7		22.14	-1.15	18.84	7.00	38.45	PASS
		1	14		22.22	-1.15	18.92	7.00	38.45	PASS
		8	0		21.39	-1.15	18.09	7.00	38.45	PASS
		8	4		21.37	-1.15	18.07	7.00	38.45	PASS
		8	7		21.46	-1.15	18.16	7.00	38.45	PASS
		15	0		21.25	-1.15	17.95	7.00	38.45	PASS
		Middle	QPSK	1	0	23.55	-1.15	20.25	7.00	38.45
	1			7	23.47	-1.15	20.17	7.00	38.45	PASS
	1			14	23.45	-1.15	20.15	7.00	38.45	PASS
	8			0	22.71	-1.15	19.41	7.00	38.45	PASS
	8			4	22.70	-1.15	19.40	7.00	38.45	PASS
	8			7	22.52	-1.15	19.22	7.00	38.45	PASS
	15			0	22.55	-1.15	19.25	7.00	38.45	PASS
	16QAM		1	0	23.32	-1.15	20.02	7.00	38.45	PASS
			1	7	23.27	-1.15	19.97	7.00	38.45	PASS
			1	14	23.23	-1.15	19.93	7.00	38.45	PASS
			8	0	21.61	-1.15	18.31	7.00	38.45	PASS
			8	4	21.54	-1.15	18.24	7.00	38.45	PASS
			8	7	21.57	-1.15	18.27	7.00	38.45	PASS
			15	0	21.54	-1.15	18.24	7.00	38.45	PASS
			Highest	QPSK	1	0	23.88	-1.15	20.58	7.00
	1	7			23.82	-1.15	20.52	7.00	38.45	PASS
	1	14			23.70	-1.15	20.40	7.00	38.45	PASS
	8	0			22.56	-1.15	19.26	7.00	38.45	PASS
	8	4			22.55	-1.15	19.25	7.00	38.45	PASS
	8	7			22.58	-1.15	19.28	7.00	38.45	PASS
	15	0			22.61	-1.15	19.31	7.00	38.45	PASS
	16QAM	1		0	22.90	-1.15	19.60	7.00	38.45	PASS
1		7		22.80	-1.15	19.50	7.00	38.45	PASS	
1		14		22.89	-1.15	19.59	7.00	38.45	PASS	
8		0		21.50	-1.15	18.20	7.00	38.45	PASS	
8		4		21.47	-1.15	18.17	7.00	38.45	PASS	
8		7		21.59	-1.15	18.29	7.00	38.45	PASS	
15		0		21.60	-1.15	18.30	7.00	38.45	PASS	



Radiated Power (ERP) for LTE Band 5 /5M										
BW (MHz)	UL Channel	RB Size	RB offset	Modulation	Conduction AVG Power(dBm)	Ant Gain (dBi)	ERP (dBm)	ERP Limit(W)	ERP Limit(dBm)	Verdict
5	Lowest	1	0	QPSK	23.27	-1.15	19.97	7.00	38.45	PASS
		1	12		23.30	-1.15	20.00	7.00	38.45	PASS
		1	24		23.35	-1.15	20.05	7.00	38.45	PASS
		12	0		22.38	-1.15	19.08	7.00	38.45	PASS
		12	6		22.37	-1.15	19.07	7.00	38.45	PASS
		12	11		22.29	-1.15	18.99	7.00	38.45	PASS
		25	0		22.35	-1.15	19.05	7.00	38.45	PASS
		1	0	16QAM	22.30	-1.15	19.00	7.00	38.45	PASS
		1	12		22.30	-1.15	19.00	7.00	38.45	PASS
		1	24		22.38	-1.15	19.08	7.00	38.45	PASS
		12	0		21.25	-1.15	17.95	7.00	38.45	PASS
		12	6		21.42	-1.15	18.12	7.00	38.45	PASS
		12	11		21.36	-1.15	18.06	7.00	38.45	PASS
		25	0		21.51	-1.15	18.21	7.00	38.45	PASS
	Middle	QPSK	1	0	23.69	-1.15	20.39	7.00	38.45	PASS
			1	12	23.66	-1.15	20.36	7.00	38.45	PASS
			1	24	23.72	-1.15	20.42	7.00	38.45	PASS
			12	0	22.55	-1.15	19.25	7.00	38.45	PASS
			12	6	22.55	-1.15	19.25	7.00	38.45	PASS
			12	11	22.57	-1.15	19.27	7.00	38.45	PASS
			25	0	22.59	-1.15	19.29	7.00	38.45	PASS
		16QAM	1	0	22.69	-1.15	19.39	7.00	38.45	PASS
			1	12	22.71	-1.15	19.41	7.00	38.45	PASS
			1	24	22.71	-1.15	19.41	7.00	38.45	PASS
			12	0	21.66	-1.15	18.36	7.00	38.45	PASS
			12	6	21.58	-1.15	18.28	7.00	38.45	PASS
			12	11	21.64	-1.15	18.34	7.00	38.45	PASS
			25	0	21.54	-1.15	18.24	7.00	38.45	PASS
	Highest	QPSK	1	0	23.59	-1.15	20.29	7.00	38.45	PASS
			1	12	23.63	-1.15	20.33	7.00	38.45	PASS
			1	24	23.48	-1.15	20.18	7.00	38.45	PASS
			12	0	22.62	-1.15	19.32	7.00	38.45	PASS
			12	6	22.64	-1.15	19.34	7.00	38.45	PASS
			12	11	22.49	-1.15	19.19	7.00	38.45	PASS
			25	0	22.47	-1.15	19.17	7.00	38.45	PASS
		16QAM	1	0	22.15	-1.15	18.85	7.00	38.45	PASS
1			12	22.19	-1.15	18.89	7.00	38.45	PASS	
1			24	22.19	-1.15	18.89	7.00	38.45	PASS	
12			0	21.77	-1.15	18.47	7.00	38.45	PASS	
12			6	21.66	-1.15	18.36	7.00	38.45	PASS	
12			11	21.58	-1.15	18.28	7.00	38.45	PASS	
25			0	21.45	-1.15	18.15	7.00	38.45	PASS	



Radiated Power (ERP) for LTE Band 5 /10M										
BW (MHz)	UL Channel	RB Size	RB offset	Modulation	Conduction AVG Power(dBm)	Ant Gain (dBi)	ERP (dBm)	ERP Limit(W)	ERP Limit(dBm)	Verdict
10	Lowest	1	0	QPSK	23.62	-1.15	20.32	7.00	38.45	PASS
		1	24		23.67	-1.15	20.37	7.00	38.45	PASS
		1	49		23.64	-1.15	20.34	7.00	38.45	PASS
		25	0		22.37	-1.15	19.07	7.00	38.45	PASS
		25	12		22.44	-1.15	19.14	7.00	38.45	PASS
		25	24		22.50	-1.15	19.20	7.00	38.45	PASS
		50	0	22.45	-1.15	19.15	7.00	38.45	PASS	
		1	0	16QAM	22.13	-1.15	18.83	7.00	38.45	PASS
		1	24		22.13	-1.15	18.83	7.00	38.45	PASS
		1	49		22.22	-1.15	18.92	7.00	38.45	PASS
		25	0		21.47	-1.15	18.17	7.00	38.45	PASS
		25	12		21.52	-1.15	18.22	7.00	38.45	PASS
		25	24		21.60	-1.15	18.30	7.00	38.45	PASS
		50	0	21.56	-1.15	18.26	7.00	38.45	PASS	
	Middle	QPSK	1	0	23.54	-1.15	20.24	7.00	38.45	PASS
			1	24	23.60	-1.15	20.30	7.00	38.45	PASS
			1	49	23.76	-1.15	20.46	7.00	38.45	PASS
			25	0	22.67	-1.15	19.37	7.00	38.45	PASS
			25	12	22.52	-1.15	19.22	7.00	38.45	PASS
			25	24	22.68	-1.15	19.38	7.00	38.45	PASS
		50	0	22.55	-1.15	19.25	7.00	38.45	PASS	
		16QAM	1	0	22.91	-1.15	19.61	7.00	38.45	PASS
			1	24	23.06	-1.15	19.76	7.00	38.45	PASS
			1	49	23.00	-1.15	19.70	7.00	38.45	PASS
			25	0	21.76	-1.15	18.46	7.00	38.45	PASS
			25	12	21.67	-1.15	18.37	7.00	38.45	PASS
			25	24	21.70	-1.15	18.40	7.00	38.45	PASS
			50	0	21.59	-1.15	18.29	7.00	38.45	PASS
	Highest		QPSK	1	0	23.75	-1.15	20.45	7.00	38.45
		1		24	23.89	-1.15	20.59	7.00	38.45	PASS
		1		49	23.80	-1.15	20.50	7.00	38.45	PASS
		25		0	22.67	-1.15	19.37	7.00	38.45	PASS
		25		12	22.61	-1.15	19.31	7.00	38.45	PASS
		25		24	22.63	-1.15	19.33	7.00	38.45	PASS
		50	0	22.64	-1.15	19.34	7.00	38.45	PASS	
		16QAM	1	0	22.76	-1.15	19.46	7.00	38.45	PASS
1			24	22.70	-1.15	19.40	7.00	38.45	PASS	
1			49	22.71	-1.15	19.41	7.00	38.45	PASS	
25			0	21.79	-1.15	18.49	7.00	38.45	PASS	
25			12	21.65	-1.15	18.35	7.00	38.45	PASS	
25			24	21.59	-1.15	18.29	7.00	38.45	PASS	
50			0	21.59	-1.15	18.29	7.00	38.45	PASS	



Radiated Power (EIRP) for LTE Band 7 /5M										
BW (MHz)	UL Channel	RB Size	RB offset	Modulation	Conduction AVG Power(dBm)	Ant Gain (dBi)	EIRP (dBm)	EIRP Limit(W)	EIRP Limit(dBm)	Verdict
5	Lowest	1	0	QPSK	23.05	2.01	25.06	2.00	33.01	PASS
		1	12		23.08	2.01	25.09	2.00	33.01	PASS
		1	24		23.11	2.01	25.12	2.00	33.01	PASS
		12	0		22.11	2.01	24.12	2.00	33.01	PASS
		12	6		22.03	2.01	24.04	2.00	33.01	PASS
		12	11		22.15	2.01	24.16	2.00	33.01	PASS
		25	0	22.15	2.01	24.16	2.00	33.01	PASS	
		1	0	16QAM	22.01	2.01	24.02	2.00	33.01	PASS
		1	12		21.99	2.01	24.00	2.00	33.01	PASS
		1	24		22.05	2.01	24.06	2.00	33.01	PASS
		12	0		21.09	2.01	23.10	2.00	33.01	PASS
		12	6		21.11	2.01	23.12	2.00	33.01	PASS
		12	11		21.13	2.01	23.14	2.00	33.01	PASS
		25	0	21.31	2.01	23.32	2.00	33.01	PASS	
		1	0	QPSK	23.71	2.01	25.72	2.00	33.01	PASS
	1	12	23.69		2.01	25.70	2.00	33.01	PASS	
	1	24	23.72		2.01	25.73	2.00	33.01	PASS	
	12	0	22.61		2.01	24.62	2.00	33.01	PASS	
	12	6	22.55		2.01	24.56	2.00	33.01	PASS	
	12	11	22.56		2.01	24.57	2.00	33.01	PASS	
	25	0	22.52	2.01	24.53	2.00	33.01	PASS		
	1	0	16QAM	22.61	2.01	24.62	2.00	33.01	PASS	
	1	12		22.65	2.01	24.66	2.00	33.01	PASS	
	1	24		22.69	2.01	24.70	2.00	33.01	PASS	
	12	0		21.69	2.01	23.70	2.00	33.01	PASS	
	12	6		21.73	2.01	23.74	2.00	33.01	PASS	
	12	11		21.68	2.01	23.69	2.00	33.01	PASS	
	25	0	21.70	2.01	23.71	2.00	33.01	PASS		
	1	0	QPSK	23.33	2.01	25.34	2.00	33.01	PASS	
	1	12		23.23	2.01	25.24	2.00	33.01	PASS	
	1	24		23.30	2.01	25.31	2.00	33.01	PASS	
	12	0		22.46	2.01	24.47	2.00	33.01	PASS	
	12	6		22.40	2.01	24.41	2.00	33.01	PASS	
	12	11		22.33	2.01	24.34	2.00	33.01	PASS	
	25	0	22.31	2.01	24.32	2.00	33.01	PASS		
	1	0	16QAM	22.07	2.01	24.08	2.00	33.01	PASS	
	1	12		21.99	2.01	24.00	2.00	33.01	PASS	
	1	24		22.07	2.01	24.08	2.00	33.01	PASS	
	12	0		21.48	2.01	23.49	2.00	33.01	PASS	
	12	6		21.46	2.01	23.47	2.00	33.01	PASS	
	12	11		21.54	2.01	23.55	2.00	33.01	PASS	
	25	0	21.44	2.01	23.45	2.00	33.01	PASS		



Radiated Power (EIRP) for LTE Band 7 /10M										
BW (MHz)	UL Channel	RB Size	RB offset	Modulation	Conduction AVG Power(dBm)	Ant Gain (dBi)	EIRP (dBm)	EIRP Limit(W)	EIRP Limit(dBm)	Verdict
10	Lowest	1	0	QPSK	22.82	2.01	24.83	2.00	33.01	PASS
		1	24		22.83	2.01	24.84	2.00	33.01	PASS
		1	49		22.94	2.01	24.95	2.00	33.01	PASS
		25	0		21.65	2.01	23.66	2.00	33.01	PASS
		25	12		21.70	2.01	23.71	2.00	33.01	PASS
		25	24		21.76	2.01	23.77	2.00	33.01	PASS
		50	0	21.72	2.01	23.73	2.00	33.01	PASS	
		1	0	16QAM	21.45	2.01	23.46	2.00	33.01	PASS
		1	24		21.49	2.01	23.50	2.00	33.01	PASS
		1	49		21.57	2.01	23.58	2.00	33.01	PASS
		25	0		20.83	2.01	22.84	2.00	33.01	PASS
		25	12		20.91	2.01	22.92	2.00	33.01	PASS
		25	24		20.82	2.01	22.83	2.00	33.01	PASS
		50	0	20.87	2.01	22.88	2.00	33.01	PASS	
		Middle	QPSK	1	0	23.04	2.01	25.05	2.00	33.01
	1			24	23.12	2.01	25.13	2.00	33.01	PASS
	1			49	23.15	2.01	25.16	2.00	33.01	PASS
	25			0	22.22	2.01	24.23	2.00	33.01	PASS
	25			12	22.16	2.01	24.17	2.00	33.01	PASS
	25			24	22.21	2.01	24.22	2.00	33.01	PASS
	50		0	22.28	2.01	24.29	2.00	33.01	PASS	
	16QAM		1	0	22.78	2.01	24.79	2.00	33.01	PASS
			1	24	22.79	2.01	24.80	2.00	33.01	PASS
			1	49	22.83	2.01	24.84	2.00	33.01	PASS
			25	0	21.34	2.01	23.35	2.00	33.01	PASS
			25	12	21.40	2.01	23.41	2.00	33.01	PASS
			25	24	21.35	2.01	23.36	2.00	33.01	PASS
	50		0	21.37	2.01	23.38	2.00	33.01	PASS	
	Highest		QPSK	1	0	23.25	2.01	25.26	2.00	33.01
		1		24	23.27	2.01	25.28	2.00	33.01	PASS
		1		49	23.19	2.01	25.20	2.00	33.01	PASS
		25		0	21.97	2.01	23.98	2.00	33.01	PASS
		25		12	21.95	2.01	23.96	2.00	33.01	PASS
		25		24	21.92	2.01	23.93	2.00	33.01	PASS
		50	0	22.00	2.01	24.01	2.00	33.01	PASS	
		16QAM	1	0	22.40	2.01	24.41	2.00	33.01	PASS
			1	24	22.46	2.01	24.47	2.00	33.01	PASS
			1	49	22.41	2.01	24.42	2.00	33.01	PASS
			25	0	21.12	2.01	23.13	2.00	33.01	PASS
			25	12	21.14	2.01	23.15	2.00	33.01	PASS
			25	24	21.13	2.01	23.14	2.00	33.01	PASS
		50	0	21.24	2.01	23.25	2.00	33.01	PASS	



Radiated Power (EIRP) for LTE Band 7 /15M										
BW (MHz)	UL Channel	RB Size	RB offset	Modulation	Conduction AVG Power(dBm)	Ant Gain (dBi)	EIRP (dBm)	EIRP Limit(W)	EIRP Limit(dBm)	Verdict
15	Lowest	1	0	QPSK	22.83	2.01	24.84	2.00	33.01	PASS
		1	37		22.84	2.01	24.85	2.00	33.01	PASS
		1	74		22.87	2.01	24.88	2.00	33.01	PASS
		36	0		21.66	2.01	23.67	2.00	33.01	PASS
		36	18		21.70	2.01	23.71	2.00	33.01	PASS
		36	39		21.83	2.01	23.84	2.00	33.01	PASS
		75	0		21.72	2.01	23.73	2.00	33.01	PASS
		1	0	16QAM	21.37	2.01	23.38	2.00	33.01	PASS
		1	37		21.40	2.01	23.41	2.00	33.01	PASS
		1	74		21.42	2.01	23.43	2.00	33.01	PASS
		36	0		20.93	2.01	22.94	2.00	33.01	PASS
		36	18		20.90	2.01	22.91	2.00	33.01	PASS
		36	39		20.98	2.01	22.99	2.00	33.01	PASS
		75	0		20.91	2.01	22.92	2.00	33.01	PASS
	1	0	QPSK	22.93	2.01	24.94	2.00	33.01	PASS	
	1	37		23.06	2.01	25.07	2.00	33.01	PASS	
	1	74		23.09	2.01	25.10	2.00	33.01	PASS	
	36	0		22.13	2.01	24.14	2.00	33.01	PASS	
	36	18		22.28	2.01	24.29	2.00	33.01	PASS	
	36	39		22.20	2.01	24.21	2.00	33.01	PASS	
	75	0		22.10	2.01	24.11	2.00	33.01	PASS	
	1	0	16QAM	22.69	2.01	24.70	2.00	33.01	PASS	
	1	37		22.77	2.01	24.78	2.00	33.01	PASS	
	1	74		22.71	2.01	24.72	2.00	33.01	PASS	
	36	0		21.25	2.01	23.26	2.00	33.01	PASS	
	36	18		21.23	2.01	23.24	2.00	33.01	PASS	
	36	39		21.31	2.01	23.32	2.00	33.01	PASS	
	75	0		21.32	2.01	23.33	2.00	33.01	PASS	
	1	0	QPSK	23.09	2.01	25.10	2.00	33.01	PASS	
	1	37		23.10	2.01	25.11	2.00	33.01	PASS	
	1	74		23.08	2.01	25.09	2.00	33.01	PASS	
	36	0		22.04	2.01	24.05	2.00	33.01	PASS	
	36	18		21.88	2.01	23.89	2.00	33.01	PASS	
	36	39		21.97	2.01	23.98	2.00	33.01	PASS	
	75	0		21.96	2.01	23.97	2.00	33.01	PASS	
	1	0	16QAM	21.88	2.01	23.89	2.00	33.01	PASS	
	1	37		21.80	2.01	23.81	2.00	33.01	PASS	
	1	74		21.82	2.01	23.83	2.00	33.01	PASS	
	36	0		21.08	2.01	23.09	2.00	33.01	PASS	
	36	18		21.05	2.01	23.06	2.00	33.01	PASS	
	36	39		21.14	2.01	23.15	2.00	33.01	PASS	
	75	0		21.17	2.01	23.18	2.00	33.01	PASS	



Radiated Power (EIRP) for LTE Band 7 /20M										
BW (MHz)	UL Channel	RB Size	RB offset	Modulation	Conduction AVG Power(dBm)	Ant Gain (dBi)	EIRP (dBm)	EIRP Limit(W)	EIRP Limit(dBm)	Verdict
20	Lowest	1	0	QPSK	22.64	2.01	24.65	2.00	33.01	PASS
		1	49		22.72	2.01	24.73	2.00	33.01	PASS
		1	99		22.68	2.01	24.69	2.00	33.01	PASS
		50	0		21.78	2.01	23.79	2.00	33.01	PASS
		50	24		21.82	2.01	23.83	2.00	33.01	PASS
		50	49		21.81	2.01	23.82	2.00	33.01	PASS
		100	0	21.72	2.01	23.73	2.00	33.01	PASS	
		1	0	16QAM	21.97	2.01	23.98	2.00	33.01	PASS
		1	49		21.96	2.01	23.97	2.00	33.01	PASS
		1	99		22.03	2.01	24.04	2.00	33.01	PASS
		50	0		20.85	2.01	22.86	2.00	33.01	PASS
		50	24		20.94	2.01	22.95	2.00	33.01	PASS
		50	49		20.93	2.01	22.94	2.00	33.01	PASS
		100	0	20.82	2.01	22.83	2.00	33.01	PASS	
		1	0	QPSK	23.11	2.01	25.12	2.00	33.01	PASS
		1	49		23.28	2.01	25.29	2.00	33.01	PASS
	1	99	23.73		2.01	25.74	2.00	33.01	PASS	
	50	0	22.22		2.01	24.23	2.00	33.01	PASS	
	50	24	22.27		2.01	24.28	2.00	33.01	PASS	
	50	49	22.25		2.01	24.26	2.00	33.01	PASS	
	100	0	22.16	2.01	24.17	2.00	33.01	PASS		
	1	0	16QAM	22.89	2.01	24.90	2.00	33.01	PASS	
	1	49		23.01	2.01	25.02	2.00	33.01	PASS	
	1	99		22.96	2.01	24.97	2.00	33.01	PASS	
	50	0		21.34	2.01	23.35	2.00	33.01	PASS	
	50	24		21.39	2.01	23.40	2.00	33.01	PASS	
	50	49		21.37	2.01	23.38	2.00	33.01	PASS	
	100	0	21.34	2.01	23.35	2.00	33.01	PASS		
	1	0	QPSK	22.95	2.01	24.96	2.00	33.01	PASS	
	1	49		23.00	2.01	25.01	2.00	33.01	PASS	
	1	99		23.05	2.01	25.06	2.00	33.01	PASS	
	50	0		22.03	2.01	24.04	2.00	33.01	PASS	
	50	24		21.95	2.01	23.96	2.00	33.01	PASS	
	50	49		22.06	2.01	24.07	2.00	33.01	PASS	
	100	0	21.98	2.01	23.99	2.00	33.01	PASS		
	1	0	16QAM	22.30	2.01	24.31	2.00	33.01	PASS	
	1	49		22.34	2.01	24.35	2.00	33.01	PASS	
	1	99		22.27	2.01	24.28	2.00	33.01	PASS	
	50	0		21.14	2.01	23.15	2.00	33.01	PASS	
	50	24		21.17	2.01	23.18	2.00	33.01	PASS	
	50	49		21.18	2.01	23.19	2.00	33.01	PASS	
	100	0	21.20	2.01	23.21	2.00	33.01	PASS		



Radiated Power (ERP) for LTE Band 12 /1.4M											
BW (MHz)	UL Channel	RB Size	RB offset	Modulation	Conduction AVG Power(dBm)	Ant Gain (dBi)	ERP (dBm)	ERP Limit(W)	ERP Limit(dBm)	Verdict	
1.4	Lowest	1	0	QPSK	23.93	-5.85	15.93	3.00	34.77	PASS	
		1	2		23.96	-5.85	15.96	3.00	34.77	PASS	
		1	5		23.96	-5.85	15.96	3.00	34.77	PASS	
		3	0		23.77	-5.85	15.77	3.00	34.77	PASS	
		3	1		23.77	-5.85	15.77	3.00	34.77	PASS	
		3	2		23.78	-5.85	15.78	3.00	34.77	PASS	
		6	0	22.74	-5.85	14.74	3.00	34.77	PASS		
		1	0	16QAM	23.30	-5.85	15.30	3.00	34.77	PASS	
		1	2		23.53	-5.85	15.53	3.00	34.77	PASS	
		1	5		23.44	-5.85	15.44	3.00	34.77	PASS	
		3	0		22.59	-5.85	14.59	3.00	34.77	PASS	
		3	1		22.63	-5.85	14.63	3.00	34.77	PASS	
	3	2	22.59		-5.85	14.59	3.00	34.77	PASS		
	6	0	21.54	-5.85	13.54	3.00	34.77	PASS			
	1	Middle	1	0	QPSK	23.61	-5.85	15.61	3.00	34.77	PASS
	1		2	23.64		-5.85	15.64	3.00	34.77	PASS	
	1		5	23.62		-5.85	15.62	3.00	34.77	PASS	
	3		0	23.61		-5.85	15.61	3.00	34.77	PASS	
	3		1	23.60		-5.85	15.60	3.00	34.77	PASS	
	3		2	23.74		-5.85	15.74	3.00	34.77	PASS	
	6		0	22.55	-5.85	14.55	3.00	34.77	PASS		
	1		0	16QAM	23.26	-5.85	15.26	3.00	34.77	PASS	
	1		2		23.18	-5.85	15.18	3.00	34.77	PASS	
	1		5		23.23	-5.85	15.23	3.00	34.77	PASS	
	3		0		22.53	-5.85	14.53	3.00	34.77	PASS	
	3		1		22.51	-5.85	14.51	3.00	34.77	PASS	
	3	2	22.54		-5.85	14.54	3.00	34.77	PASS		
	6	0	21.88	-5.85	13.88	3.00	34.77	PASS			
	1	Highest	1	0	QPSK	23.80	-5.85	15.80	3.00	34.77	PASS
	1		2	23.83		-5.85	15.83	3.00	34.77	PASS	
	1		5	23.79		-5.85	15.79	3.00	34.77	PASS	
	3		0	23.69		-5.85	15.69	3.00	34.77	PASS	
	3		1	23.75		-5.85	15.75	3.00	34.77	PASS	
	3		2	23.67		-5.85	15.67	3.00	34.77	PASS	
	6		0	22.61	-5.85	14.61	3.00	34.77	PASS		
	1		0	16QAM	22.95	-5.85	14.95	3.00	34.77	PASS	
1	2		22.84		-5.85	14.84	3.00	34.77	PASS		
1	5		22.87		-5.85	14.87	3.00	34.77	PASS		
3	0		22.86		-5.85	14.86	3.00	34.77	PASS		
3	1		22.62		-5.85	14.62	3.00	34.77	PASS		
3	2	22.65	-5.85		14.65	3.00	34.77	PASS			
6	0	21.64	-5.85	13.64	3.00	34.77	PASS				



Radiated Power (ERP) for LTE Band 12 /3M											
BW (MHz)	UL Channel	RB Size	RB offset	Modulation	Conduction AVG Power(dBm)	Ant Gain (dBi)	ERP (dBm)	ERP Limit(W)	ERP Limit(dBm)	Verdict	
3	Lowest	1	0	QPSK	23.76	-5.85	15.76	3.00	34.77	PASS	
		1	7		23.76	-5.85	15.76	3.00	34.77	PASS	
		1	14		23.68	-5.85	15.68	3.00	34.77	PASS	
		8	0		22.62	-5.85	14.62	3.00	34.77	PASS	
		8	4		22.53	-5.85	14.53	3.00	34.77	PASS	
		8	7		22.59	-5.85	14.59	3.00	34.77	PASS	
		15	0	22.62	-5.85	14.62	3.00	34.77	PASS		
		1	0	16QAM	22.33	-5.85	14.33	3.00	34.77	PASS	
		1	7		22.31	-5.85	14.31	3.00	34.77	PASS	
		1	14		22.38	-5.85	14.38	3.00	34.77	PASS	
		8	0		21.80	-5.85	13.80	3.00	34.77	PASS	
		8	4		21.69	-5.85	13.69	3.00	34.77	PASS	
		8	7		22.04	-5.85	14.04	3.00	34.77	PASS	
		15	0	21.52	-5.85	13.52	3.00	34.77	PASS		
		Middle	QPSK	1	0	23.63	-5.85	15.63	3.00	34.77	PASS
	1			7	23.58	-5.85	15.58	3.00	34.77	PASS	
	1			14	23.56	-5.85	15.56	3.00	34.77	PASS	
	8			0	22.71	-5.85	14.71	3.00	34.77	PASS	
	8			4	22.64	-5.85	14.64	3.00	34.77	PASS	
	8			7	22.56	-5.85	14.56	3.00	34.77	PASS	
	15		0	22.67	-5.85	14.67	3.00	34.77	PASS		
	16QAM		1	0	23.31	-5.85	15.31	3.00	34.77	PASS	
			1	7	23.26	-5.85	15.26	3.00	34.77	PASS	
			1	14	23.21	-5.85	15.21	3.00	34.77	PASS	
			8	0	21.61	-5.85	13.61	3.00	34.77	PASS	
			8	4	21.81	-5.85	13.81	3.00	34.77	PASS	
			8	7	21.85	-5.85	13.85	3.00	34.77	PASS	
			15	0	21.88	-5.85	13.88	3.00	34.77	PASS	
			Highest	QPSK	1	0	23.83	-5.85	15.83	3.00	34.77
		1			7	23.87	-5.85	15.87	3.00	34.77	PASS
	1	14			23.82	-5.85	15.82	3.00	34.77	PASS	
	8	0			22.85	-5.85	14.85	3.00	34.77	PASS	
	8	4			22.75	-5.85	14.75	3.00	34.77	PASS	
	8	7			22.53	-5.85	14.53	3.00	34.77	PASS	
	15	0		22.87	-5.85	14.87	3.00	34.77	PASS		
	16QAM	1		0	22.98	-5.85	14.98	3.00	34.77	PASS	
1		7		22.97	-5.85	14.97	3.00	34.77	PASS		
1		14		22.81	-5.85	14.81	3.00	34.77	PASS		
8		0		21.79	-5.85	13.79	3.00	34.77	PASS		
8		4		21.74	-5.85	13.74	3.00	34.77	PASS		
8		7		21.48	-5.85	13.48	3.00	34.77	PASS		
15		0		21.84	-5.85	13.84	3.00	34.77	PASS		



Radiated Power (ERP) for LTE Band 12 /5M										
BW (MHz)	UL Channel	RB Size	RB offset	Modulation	Conduction AVG Power(dBm)	Ant Gain (dBi)	ERP (dBm)	ERP Limit(W)	ERP Limit(dBm)	Verdict
5	Lowest	1	0	QPSK	23.61	-5.85	15.61	3.00	34.77	PASS
		1	12		23.56	-5.85	15.56	3.00	34.77	PASS
		1	24		23.63	-5.85	15.63	3.00	34.77	PASS
		12	0		22.55	-5.85	14.55	3.00	34.77	PASS
		12	6		22.63	-5.85	14.63	3.00	34.77	PASS
		12	11		22.64	-5.85	14.64	3.00	34.77	PASS
		25	0		22.71	-5.85	14.71	3.00	34.77	PASS
		1	0	16QAM	22.58	-5.85	14.58	3.00	34.77	PASS
		1	12		22.53	-5.85	14.53	3.00	34.77	PASS
		1	24		22.56	-5.85	14.56	3.00	34.77	PASS
		12	0		21.53	-5.85	13.53	3.00	34.77	PASS
		12	6		21.86	-5.85	13.86	3.00	34.77	PASS
		12	11		21.86	-5.85	13.86	3.00	34.77	PASS
		25	0		22.00	-5.85	14.00	3.00	34.77	PASS
		Middle	QPSK	1	0	23.78	-5.85	15.78	3.00	34.77
	1			12	23.65	-5.85	15.65	3.00	34.77	PASS
	1			24	23.79	-5.85	15.79	3.00	34.77	PASS
	12			0	22.61	-5.85	14.61	3.00	34.77	PASS
	12			6	22.61	-5.85	14.61	3.00	34.77	PASS
	12			11	22.50	-5.85	14.50	3.00	34.77	PASS
	25			0	22.64	-5.85	14.64	3.00	34.77	PASS
	16QAM		1	0	22.57	-5.85	14.57	3.00	34.77	PASS
			1	12	22.58	-5.85	14.58	3.00	34.77	PASS
			1	24	22.64	-5.85	14.64	3.00	34.77	PASS
			12	0	21.64	-5.85	13.64	3.00	34.77	PASS
			12	6	21.93	-5.85	13.93	3.00	34.77	PASS
			12	11	21.85	-5.85	13.85	3.00	34.77	PASS
			25	0	21.88	-5.85	13.88	3.00	34.77	PASS
			Highest	QPSK	1	0	23.59	-5.85	15.59	3.00
	1	12			23.59	-5.85	15.59	3.00	34.77	PASS
	1	24			23.61	-5.85	15.61	3.00	34.77	PASS
	12	0			22.88	-5.85	14.88	3.00	34.77	PASS
	12	6			22.81	-5.85	14.81	3.00	34.77	PASS
	12	11			22.78	-5.85	14.78	3.00	34.77	PASS
	25	0			22.79	-5.85	14.79	3.00	34.77	PASS
	16QAM	1		0	22.41	-5.85	14.41	3.00	34.77	PASS
1		12		22.43	-5.85	14.43	3.00	34.77	PASS	
1		24		22.21	-5.85	14.21	3.00	34.77	PASS	
12		0		21.88	-5.85	13.88	3.00	34.77	PASS	
12		6		21.88	-5.85	13.88	3.00	34.77	PASS	
12		11		21.89	-5.85	13.89	3.00	34.77	PASS	
25		0		21.74	-5.85	13.74	3.00	34.77	PASS	



Radiated Power (ERP) for LTE Band 12 /10M												
BW (MHz)	UL Channel	RB Size	RB offset	Modulation	Conduction AVG Power(dBm)	Ant Gain (dBi)	ERP (dBm)	ERP Limit(W)	ERP Limit(dBm)	Verdict		
10	Lowest	1	0	QPSK	23.82	-5.85	15.82	3.00	34.77	PASS		
		1	24		23.71	-5.85	15.71	3.00	34.77	PASS		
		1	49		23.73	-5.85	15.73	3.00	34.77	PASS		
		25	0		22.73	-5.85	14.73	3.00	34.77	PASS		
		25	12		22.61	-5.85	14.61	3.00	34.77	PASS		
		25	24		22.75	-5.85	14.75	3.00	34.77	PASS		
		50	0	22.60	-5.85	14.60	3.00	34.77	PASS			
		16QAM	1	0	16QAM	22.29	-5.85	14.29	3.00	34.77	PASS	
			1	24		22.38	-5.85	14.38	3.00	34.77	PASS	
			1	49		22.32	-5.85	14.32	3.00	34.77	PASS	
			25	0		21.97	-5.85	13.97	3.00	34.77	PASS	
			25	12		21.74	-5.85	13.74	3.00	34.77	PASS	
			25	24		21.64	-5.85	13.64	3.00	34.77	PASS	
			50	0		21.77	-5.85	13.77	3.00	34.77	PASS	
			Middle	1		0	QPSK	23.46	-5.85	15.46	3.00	34.77
	1			24		23.66		-5.85	15.66	3.00	34.77	PASS
	1	49		23.62	-5.85	15.62		3.00	34.77	PASS		
	25	0		22.60	-5.85	14.60		3.00	34.77	PASS		
	25	12		22.62	-5.85	14.62		3.00	34.77	PASS		
	25	24		22.78	-5.85	14.78		3.00	34.77	PASS		
	50	0		22.63	-5.85	14.63	3.00	34.77	PASS			
	16QAM	1		0	16QAM	23.05	-5.85	15.05	3.00	34.77	PASS	
		1		24		23.07	-5.85	15.07	3.00	34.77	PASS	
		1		49		23.19	-5.85	15.19	3.00	34.77	PASS	
		25		0		21.76	-5.85	13.76	3.00	34.77	PASS	
		25		12		21.92	-5.85	13.92	3.00	34.77	PASS	
		25		24		21.85	-5.85	13.85	3.00	34.77	PASS	
		50		0		21.95	-5.85	13.95	3.00	34.77	PASS	
		Highest		1		0	QPSK	23.97	-5.85	15.97	3.00	34.77
			1	24		23.83		-5.85	15.83	3.00	34.77	PASS
	1		49	23.90	-5.85	15.90		3.00	34.77	PASS		
	25		0	22.49	-5.85	14.49		3.00	34.77	PASS		
	25		12	22.68	-5.85	14.68		3.00	34.77	PASS		
	25		24	22.89	-5.85	14.89		3.00	34.77	PASS		
	50		0	22.61	-5.85	14.61	3.00	34.77	PASS			
	16QAM		1	0	16QAM	22.94	-5.85	14.94	3.00	34.77	PASS	
1			24	22.94		-5.85	14.94	3.00	34.77	PASS		
1			49	22.85		-5.85	14.85	3.00	34.77	PASS		
25			0	21.93		-5.85	13.93	3.00	34.77	PASS		
25			12	21.69		-5.85	13.69	3.00	34.77	PASS		
25			24	21.91		-5.85	13.91	3.00	34.77	PASS		
50			0	21.63		-5.85	13.63	3.00	34.77	PASS		



Radiated Power (ERP) for LTE Band 17 /5M										
BW (MHz)	UL Channel	RB Size	RB offset	Modulation	Conduction AVG Power(dBm)	Ant Gain (dBi)	ERP (dBm)	ERP Limit(W)	ERP Limit(dBm)	Verdict
5	Lowest	1	0	QPSK	23.67	-5.85	15.67	3.00	34.77	PASS
		1	12		23.67	-5.85	15.67	3.00	34.77	PASS
		1	24		23.75	-5.85	15.75	3.00	34.77	PASS
		12	0		22.57	-5.85	14.57	3.00	34.77	PASS
		12	6		22.70	-5.85	14.70	3.00	34.77	PASS
		12	11		22.72	-5.85	14.72	3.00	34.77	PASS
		25	0		22.67	-5.85	14.67	3.00	34.77	PASS
		1	0	16QAM	22.61	-5.85	14.61	3.00	34.77	PASS
		1	12		22.57	-5.85	14.57	3.00	34.77	PASS
		1	24		22.50	-5.85	14.50	3.00	34.77	PASS
		12	0		21.67	-5.85	13.67	3.00	34.77	PASS
		12	6		21.66	-5.85	13.66	3.00	34.77	PASS
		12	11		21.89	-5.85	13.89	3.00	34.77	PASS
		25	0		21.60	-5.85	13.60	3.00	34.77	PASS
		1	0	QPSK	23.54	-5.85	15.54	3.00	34.77	PASS
	1	12	23.62		-5.85	15.62	3.00	34.77	PASS	
	1	24	23.51		-5.85	15.51	3.00	34.77	PASS	
	12	0	22.65		-5.85	14.65	3.00	34.77	PASS	
	12	6	22.77		-5.85	14.77	3.00	34.77	PASS	
	12	11	22.80		-5.85	14.80	3.00	34.77	PASS	
	25	0	22.76		-5.85	14.76	3.00	34.77	PASS	
	1	0	16QAM	22.17	-5.85	14.17	3.00	34.77	PASS	
	1	12		22.39	-5.85	14.39	3.00	34.77	PASS	
	1	24		22.40	-5.85	14.40	3.00	34.77	PASS	
	12	0		21.87	-5.85	13.87	3.00	34.77	PASS	
	12	6		21.66	-5.85	13.66	3.00	34.77	PASS	
	12	11		21.85	-5.85	13.85	3.00	34.77	PASS	
	25	0		21.53	-5.85	13.53	3.00	34.77	PASS	
	1	0	QPSK	23.50	-5.85	15.50	3.00	34.77	PASS	
	1	12		23.58	-5.85	15.58	3.00	34.77	PASS	
	1	24		23.57	-5.85	15.57	3.00	34.77	PASS	
	12	0		22.78	-5.85	14.78	3.00	34.77	PASS	
	12	6		22.75	-5.85	14.75	3.00	34.77	PASS	
	12	11		22.74	-5.85	14.74	3.00	34.77	PASS	
	25	0		22.76	-5.85	14.76	3.00	34.77	PASS	
	1	0	16QAM	22.68	-5.85	14.68	3.00	34.77	PASS	
1	12	22.69		-5.85	14.69	3.00	34.77	PASS		
1	24	22.53		-5.85	14.53	3.00	34.77	PASS		
12	0	21.74		-5.85	13.74	3.00	34.77	PASS		
12	6	21.82		-5.85	13.82	3.00	34.77	PASS		
12	11	21.83		-5.85	13.83	3.00	34.77	PASS		
25	0	21.91		-5.85	13.91	3.00	34.77	PASS		



Radiated Power (ERP) for LTE Band 17 /10M										
BW (MHz)	UL Channel	RB Size	RB offset	Modulation	Conduction AVG Power(dBm)	Ant Gain (dBi)	ERP (dBm)	ERP Limit(W)	ERP Limit(dBm)	Verdict
10	Lowest	1	0	QPSK	23.74	-5.85	15.74	3.00	34.77	PASS
		1	24		23.69	-5.85	15.69	3.00	34.77	PASS
		1	49		23.80	-5.85	15.80	3.00	34.77	PASS
		25	0		22.61	-5.85	14.61	3.00	34.77	PASS
		25	12		22.60	-5.85	14.60	3.00	34.77	PASS
		25	24		22.75	-5.85	14.75	3.00	34.77	PASS
		50	0	22.58	-5.85	14.58	3.00	34.77	PASS	
		1	0	16QAM	22.38	-5.85	14.38	3.00	34.77	PASS
		1	24		22.32	-5.85	14.32	3.00	34.77	PASS
		1	49		22.53	-5.85	14.53	3.00	34.77	PASS
		25	0		21.58	-5.85	13.58	3.00	34.77	PASS
		25	12		21.87	-5.85	13.87	3.00	34.77	PASS
		25	24		21.92	-5.85	13.92	3.00	34.77	PASS
		50	0	21.76	-5.85	13.76	3.00	34.77	PASS	
		1	0	QPSK	23.58	-5.85	15.58	3.00	34.77	PASS
	1	24	23.64		-5.85	15.64	3.00	34.77	PASS	
	1	49	23.63		-5.85	15.63	3.00	34.77	PASS	
	25	0	22.61		-5.85	14.61	3.00	34.77	PASS	
	25	12	22.76		-5.85	14.76	3.00	34.77	PASS	
	25	24	22.75		-5.85	14.75	3.00	34.77	PASS	
	50	0	22.72	-5.85	14.72	3.00	34.77	PASS		
	1	0	16QAM	23.03	-5.85	15.03	3.00	34.77	PASS	
	1	24		23.10	-5.85	15.10	3.00	34.77	PASS	
	1	49		23.19	-5.85	15.19	3.00	34.77	PASS	
	25	0		21.98	-5.85	13.98	3.00	34.77	PASS	
	25	12		21.74	-5.85	13.74	3.00	34.77	PASS	
	25	24		21.86	-5.85	13.86	3.00	34.77	PASS	
	50	0	21.80	-5.85	13.80	3.00	34.77	PASS		
	1	0	QPSK	23.94	-5.85	15.94	3.00	34.77	PASS	
	1	24		23.86	-5.85	15.86	3.00	34.77	PASS	
	1	49		23.91	-5.85	15.91	3.00	34.77	PASS	
	25	0		22.63	-5.85	14.63	3.00	34.77	PASS	
	25	12		22.70	-5.85	14.70	3.00	34.77	PASS	
	25	24		22.89	-5.85	14.89	3.00	34.77	PASS	
	50	0	22.62	-5.85	14.62	3.00	34.77	PASS		
	1	0	16QAM	22.88	-5.85	14.88	3.00	34.77	PASS	
1	24	22.94		-5.85	14.94	3.00	34.77	PASS		
1	49	22.88		-5.85	14.88	3.00	34.77	PASS		
25	0	21.89		-5.85	13.89	3.00	34.77	PASS		
25	12	21.73		-5.85	13.73	3.00	34.77	PASS		
25	24	21.89		-5.85	13.89	3.00	34.77	PASS		
50	0	21.58	-5.85	13.58	3.00	34.77	PASS			



Radiated Power (EIRP) for LTE Band 25 /1.4M											
BW (MHz)	UL Channel	RB Size	RB offset	Modulation	Conduction AVG Power(dBm)	Ant Gain (dBi)	EIRP (dBm)	EIRP Limit(W)	EIRP Limit(dBm)	Verdict	
1.4	Lowest	1	0	QPSK	23.41	1.48	24.89	2.00	33.01	PASS	
		1	2		23.44	1.48	24.92	2.00	33.01	PASS	
		1	5		23.39	1.48	24.87	2.00	33.01	PASS	
		3	0		23.32	1.48	24.80	2.00	33.01	PASS	
		3	1		23.36	1.48	24.84	2.00	33.01	PASS	
		3	2		23.32	1.48	24.80	2.00	33.01	PASS	
		6	0	22.25	1.48	23.73	2.00	33.01	PASS		
		1	0	16QAM	22.37	1.48	23.85	2.00	33.01	PASS	
		1	2		22.40	1.48	23.88	2.00	33.01	PASS	
		1	5		22.37	1.48	23.85	2.00	33.01	PASS	
		3	0		22.35	1.48	23.83	2.00	33.01	PASS	
		3	1		22.43	1.48	23.91	2.00	33.01	PASS	
		3	2		22.43	1.48	23.91	2.00	33.01	PASS	
		6	0	21.25	1.48	22.73	2.00	33.01	PASS		
		Middle	QPSK	1	0	23.12	1.48	24.60	2.00	33.01	PASS
				1	2	23.19	1.48	24.67	2.00	33.01	PASS
				1	5	23.19	1.48	24.67	2.00	33.01	PASS
				3	0	23.19	1.48	24.67	2.00	33.01	PASS
	3			1	23.26	1.48	24.74	2.00	33.01	PASS	
	3			2	23.25	1.48	24.73	2.00	33.01	PASS	
	6		0	22.14	1.48	23.62	2.00	33.01	PASS		
	16QAM		1	0	22.14	1.48	23.62	2.00	33.01	PASS	
			1	2	22.18	1.48	23.66	2.00	33.01	PASS	
			1	5	22.16	1.48	23.64	2.00	33.01	PASS	
			3	0	22.30	1.48	23.78	2.00	33.01	PASS	
			3	1	22.25	1.48	23.73	2.00	33.01	PASS	
			3	2	22.25	1.48	23.73	2.00	33.01	PASS	
	6		0	21.34	1.48	22.82	2.00	33.01	PASS		
	Highest		QPSK	1	0	22.70	1.48	24.18	2.00	33.01	PASS
				1	2	22.73	1.48	24.21	2.00	33.01	PASS
				1	5	22.45	1.48	23.93	2.00	33.01	PASS
				3	0	22.66	1.48	24.14	2.00	33.01	PASS
		3		1	22.67	1.48	24.15	2.00	33.01	PASS	
		3		2	22.53	1.48	24.01	2.00	33.01	PASS	
		6	0	21.67	1.48	23.15	2.00	33.01	PASS		
		16QAM	1	0	21.88	1.48	23.36	2.00	33.01	PASS	
1			2	21.94	1.48	23.42	2.00	33.01	PASS		
1			5	21.67	1.48	23.15	2.00	33.01	PASS		
3			0	21.84	1.48	23.32	2.00	33.01	PASS		
3			1	21.85	1.48	23.33	2.00	33.01	PASS		
3			2	21.72	1.48	23.20	2.00	33.01	PASS		
6		0	20.86	1.48	22.34	2.00	33.01	PASS			



Radiated Power (EIRP) for LTE Band 25 /3M										
BW (MHz)	UL Channel	RB Size	RB offset	Modulation	Conduction AVG Power(dBm)	Ant Gain (dBi)	EIRP (dBm)	EIRP Limit(W)	EIRP Limit(dBm)	Verdict
3	Lowest	1	0	QPSK	23.43	1.48	24.91	2.00	33.01	PASS
		1	7		23.40	1.48	24.88	2.00	33.01	PASS
		1	14		23.41	1.48	24.89	2.00	33.01	PASS
		8	0		22.23	1.48	23.71	2.00	33.01	PASS
		8	4		22.26	1.48	23.74	2.00	33.01	PASS
		8	7		22.24	1.48	23.72	2.00	33.01	PASS
		15	0	22.24	1.48	23.72	2.00	33.01	PASS	
		1	0	16QAM	22.05	1.48	23.53	2.00	33.01	PASS
		1	7		22.04	1.48	23.52	2.00	33.01	PASS
		1	14		22.02	1.48	23.50	2.00	33.01	PASS
		8	0		21.21	1.48	22.69	2.00	33.01	PASS
		8	4		21.21	1.48	22.69	2.00	33.01	PASS
		8	7		21.19	1.48	22.67	2.00	33.01	PASS
		15	0	21.33	1.48	22.81	2.00	33.01	PASS	
		1	0	QPSK	23.27	1.48	24.75	2.00	33.01	PASS
	1	7	23.19		1.48	24.67	2.00	33.01	PASS	
	1	14	23.19		1.48	24.67	2.00	33.01	PASS	
	8	0	22.09		1.48	23.57	2.00	33.01	PASS	
	8	4	22.21		1.48	23.69	2.00	33.01	PASS	
	8	7	22.19		1.48	23.67	2.00	33.01	PASS	
	15	0	22.10	1.48	23.58	2.00	33.01	PASS		
	1	0	16QAM	22.16	1.48	23.64	2.00	33.01	PASS	
	1	7		22.17	1.48	23.65	2.00	33.01	PASS	
	1	14		22.19	1.48	23.67	2.00	33.01	PASS	
	8	0		21.17	1.48	22.65	2.00	33.01	PASS	
	8	4		21.16	1.48	22.64	2.00	33.01	PASS	
	8	7		21.19	1.48	22.67	2.00	33.01	PASS	
	15	0	21.22	1.48	22.70	2.00	33.01	PASS		
	1	0	QPSK	23.12	1.48	24.60	2.00	33.01	PASS	
	1	7		22.92	1.48	24.40	2.00	33.01	PASS	
	1	14		22.49	1.48	23.97	2.00	33.01	PASS	
	8	0		22.08	1.48	23.56	2.00	33.01	PASS	
	8	4		22.05	1.48	23.53	2.00	33.01	PASS	
	8	7		21.78	1.48	23.26	2.00	33.01	PASS	
	15	0	22.03	1.48	23.51	2.00	33.01	PASS		
	1	0	16QAM	22.30	1.48	23.78	2.00	33.01	PASS	
	1	7		22.15	1.48	23.63	2.00	33.01	PASS	
	1	14		21.71	1.48	23.19	2.00	33.01	PASS	
	8	0		21.06	1.48	22.54	2.00	33.01	PASS	
	8	4		21.10	1.48	22.58	2.00	33.01	PASS	
	8	7		20.89	1.48	22.37	2.00	33.01	PASS	
	15	0	21.09	1.48	22.57	2.00	33.01	PASS		



Radiated Power (EIRP) for LTE Band 25 /5M										
BW (MHz)	UL Channel	RB Size	RB offset	Modulation	Conduction AVG Power(dBm)	Ant Gain (dBi)	EIRP (dBm)	EIRP Limit(W)	EIRP Limit(dBm)	Verdict
5	Lowest	1	0	QPSK	23.10	1.48	24.58	2.00	33.01	PASS
		1	12		23.10	1.48	24.58	2.00	33.01	PASS
		1	24		23.13	1.48	24.61	2.00	33.01	PASS
		12	0		22.31	1.48	23.79	2.00	33.01	PASS
		12	6		22.19	1.48	23.67	2.00	33.01	PASS
		12	11		22.30	1.48	23.78	2.00	33.01	PASS
		25	0		22.23	1.48	23.71	2.00	33.01	PASS
		1	0	16QAM	22.21	1.48	23.69	2.00	33.01	PASS
		1	12		22.19	1.48	23.67	2.00	33.01	PASS
		1	24		22.19	1.48	23.67	2.00	33.01	PASS
		12	0		21.30	1.48	22.78	2.00	33.01	PASS
		12	6		21.27	1.48	22.75	2.00	33.01	PASS
		12	11		21.31	1.48	22.79	2.00	33.01	PASS
		25	0		21.41	1.48	22.89	2.00	33.01	PASS
	1	0	QPSK	23.39	1.48	24.87	2.00	33.01	PASS	
	1	12		23.38	1.48	24.86	2.00	33.01	PASS	
	1	24		23.37	1.48	24.85	2.00	33.01	PASS	
	12	0		22.14	1.48	23.62	2.00	33.01	PASS	
	12	6		22.12	1.48	23.60	2.00	33.01	PASS	
	12	11		22.18	1.48	23.66	2.00	33.01	PASS	
	25	0		22.13	1.48	23.61	2.00	33.01	PASS	
	1	0	16QAM	22.42	1.48	23.90	2.00	33.01	PASS	
	1	12		22.37	1.48	23.85	2.00	33.01	PASS	
	1	24		22.44	1.48	23.92	2.00	33.01	PASS	
	12	0		21.26	1.48	22.74	2.00	33.01	PASS	
	12	6		21.24	1.48	22.72	2.00	33.01	PASS	
	12	11		21.26	1.48	22.74	2.00	33.01	PASS	
	25	0		21.23	1.48	22.71	2.00	33.01	PASS	
	1	0	QPSK	23.05	1.48	24.53	2.00	33.01	PASS	
	1	12		23.05	1.48	24.53	2.00	33.01	PASS	
	1	24		22.31	1.48	23.79	2.00	33.01	PASS	
	12	0		22.10	1.48	23.58	2.00	33.01	PASS	
	12	6		22.15	1.48	23.63	2.00	33.01	PASS	
	12	11		21.93	1.48	23.41	2.00	33.01	PASS	
	25	0		22.07	1.48	23.55	2.00	33.01	PASS	
	1	0	16QAM	21.85	1.48	23.33	2.00	33.01	PASS	
1	12	21.87		1.48	23.35	2.00	33.01	PASS		
1	24	21.41		1.48	22.89	2.00	33.01	PASS		
12	0	21.17		1.48	22.65	2.00	33.01	PASS		
12	6	21.16		1.48	22.64	2.00	33.01	PASS		
12	11	21.13		1.48	22.61	2.00	33.01	PASS		
25	0	20.98		1.48	22.46	2.00	33.01	PASS		



Radiated Power (EIRP) for LTE Band 25 /10M										
BW (MHz)	UL Channel	RB Size	RB offset	Modulation	Conduction AVG Power(dBm)	Ant Gain (dBi)	EIRP (dBm)	EIRP Limit(W)	EIRP Limit(dBm)	Verdict
10	Lowest	1	0	QPSK	23.42	1.48	24.90	2.00	33.01	PASS
		1	24		23.41	1.48	24.89	2.00	33.01	PASS
		1	49		23.48	1.48	24.96	2.00	33.01	PASS
		25	0		22.31	1.48	23.79	2.00	33.01	PASS
		25	12		22.28	1.48	23.76	2.00	33.01	PASS
		25	24		22.31	1.48	23.79	2.00	33.01	PASS
		50	0	22.30	1.48	23.78	2.00	33.01	PASS	
		1	0	16QAM	22.08	1.48	23.56	2.00	33.01	PASS
		1	24		22.05	1.48	23.53	2.00	33.01	PASS
		1	49		22.10	1.48	23.58	2.00	33.01	PASS
		25	0		21.40	1.48	22.88	2.00	33.01	PASS
		25	12		21.35	1.48	22.83	2.00	33.01	PASS
		25	24		21.39	1.48	22.87	2.00	33.01	PASS
		50	0	21.32	1.48	22.80	2.00	33.01	PASS	
		1	0	QPSK	23.10	1.48	24.58	2.00	33.01	PASS
	1	24	23.12		1.48	24.60	2.00	33.01	PASS	
	1	49	23.21		1.48	24.69	2.00	33.01	PASS	
	25	0	22.22		1.48	23.70	2.00	33.01	PASS	
	25	12	22.21		1.48	23.69	2.00	33.01	PASS	
	25	24	22.13		1.48	23.61	2.00	33.01	PASS	
	50	0	22.07	1.48	23.55	2.00	33.01	PASS		
	1	0	16QAM	22.68	1.48	24.16	2.00	33.01	PASS	
	1	24		22.71	1.48	24.19	2.00	33.01	PASS	
	1	49		22.67	1.48	24.15	2.00	33.01	PASS	
	25	0		21.31	1.48	22.79	2.00	33.01	PASS	
	25	12		21.25	1.48	22.73	2.00	33.01	PASS	
	25	24		21.31	1.48	22.79	2.00	33.01	PASS	
	50	0	21.31	1.48	22.79	2.00	33.01	PASS		
	1	0	QPSK	23.18	1.48	24.66	2.00	33.01	PASS	
	1	24		23.08	1.48	24.56	2.00	33.01	PASS	
	1	49		22.81	1.48	24.29	2.00	33.01	PASS	
	25	0		22.08	1.48	23.56	2.00	33.01	PASS	
	25	12		22.08	1.48	23.56	2.00	33.01	PASS	
	25	24		22.14	1.48	23.62	2.00	33.01	PASS	
	50	0	22.16	1.48	23.64	2.00	33.01	PASS		
	1	0	16QAM	22.38	1.48	23.86	2.00	33.01	PASS	
	1	24		22.20	1.48	23.68	2.00	33.01	PASS	
	1	49		22.07	1.48	23.55	2.00	33.01	PASS	
	25	0		21.25	1.48	22.73	2.00	33.01	PASS	
	25	12		21.22	1.48	22.70	2.00	33.01	PASS	
	25	24		21.21	1.48	22.69	2.00	33.01	PASS	
	50	0	21.21	1.48	22.69	2.00	33.01	PASS		



Radiated Power (EIRP) for LTE Band 25 /15M										
BW (MHz)	UL Channel	RB Size	RB offset	Modulation	Conduction AVG Power(dBm)	Ant Gain (dBi)	EIRP (dBm)	EIRP Limit(W)	EIRP Limit(dBm)	Verdict
15	Lowest	1	0	QPSK	23.47	1.48	24.95	2.00	33.01	PASS
		1	37		23.48	1.48	24.96	2.00	33.01	PASS
		1	74		23.53	1.48	25.01	2.00	33.01	PASS
		36	0		22.31	1.48	23.79	2.00	33.01	PASS
		36	18		22.30	1.48	23.78	2.00	33.01	PASS
		36	39		22.32	1.48	23.80	2.00	33.01	PASS
		75	0		22.32	1.48	23.80	2.00	33.01	PASS
		1	0	16QAM	22.08	1.48	23.56	2.00	33.01	PASS
		1	37		22.09	1.48	23.57	2.00	33.01	PASS
		1	74		22.11	1.48	23.59	2.00	33.01	PASS
		36	0		21.39	1.48	22.87	2.00	33.01	PASS
		36	18		21.39	1.48	22.87	2.00	33.01	PASS
		36	39		21.37	1.48	22.85	2.00	33.01	PASS
		75	0		21.38	1.48	22.86	2.00	33.01	PASS
		Middle	QPSK	1	0	23.21	1.48	24.69	2.00	33.01
	1			37	23.09	1.48	24.57	2.00	33.01	PASS
	1			74	23.24	1.48	24.72	2.00	33.01	PASS
	36			0	22.23	1.48	23.71	2.00	33.01	PASS
	36			18	22.05	1.48	23.53	2.00	33.01	PASS
	36			39	22.19	1.48	23.67	2.00	33.01	PASS
	75			0	22.05	1.48	23.53	2.00	33.01	PASS
	16QAM		1	0	22.77	1.48	24.25	2.00	33.01	PASS
			1	37	22.67	1.48	24.15	2.00	33.01	PASS
			1	74	22.68	1.48	24.16	2.00	33.01	PASS
			36	0	21.16	1.48	22.64	2.00	33.01	PASS
			36	18	21.15	1.48	22.63	2.00	33.01	PASS
			36	39	21.21	1.48	22.69	2.00	33.01	PASS
			75	0	21.17	1.48	22.65	2.00	33.01	PASS
			Highest	QPSK	1	0	23.23	1.48	24.71	2.00
	1	37			23.06	1.48	24.54	2.00	33.01	PASS
	1	74			23.15	1.48	24.63	2.00	33.01	PASS
	36	0			22.20	1.48	23.68	2.00	33.01	PASS
	36	18			22.11	1.48	23.59	2.00	33.01	PASS
	36	39			22.02	1.48	23.50	2.00	33.01	PASS
	75	0			22.01	1.48	23.49	2.00	33.01	PASS
	16QAM	1		0	22.69	1.48	24.17	2.00	33.01	PASS
1		37		22.59	1.48	24.07	2.00	33.01	PASS	
1		74		22.55	1.48	24.03	2.00	33.01	PASS	
36		0		21.14	1.48	22.62	2.00	33.01	PASS	
36		18		21.10	1.48	22.58	2.00	33.01	PASS	
36		39		21.12	1.48	22.60	2.00	33.01	PASS	
75		0		21.17	1.48	22.65	2.00	33.01	PASS	



Radiated Power (EIRP) for LTE Band 25 /20M										
BW (MHz)	UL Channel	RB Size	RB offset	Modulation	Conduction AVG Power(dBm)	Ant Gain (dBi)	EIRP (dBm)	EIRP Limit(W)	EIRP Limit(dBm)	Verdict
20	Lowest	1	0	QPSK	23.40	1.48	24.88	2.00	33.01	PASS
		1	49		23.38	1.48	24.86	2.00	33.01	PASS
		1	99		23.39	1.48	24.87	2.00	33.01	PASS
		50	0		22.32	1.48	23.80	2.00	33.01	PASS
		50	24		22.19	1.48	23.67	2.00	33.01	PASS
		50	49		22.27	1.48	23.75	2.00	33.01	PASS
		100	0	22.20	1.48	23.68	2.00	33.01	PASS	
		1	0	16QAM	22.44	1.48	23.92	2.00	33.01	PASS
		1	49		22.47	1.48	23.95	2.00	33.01	PASS
		1	99		22.39	1.48	23.87	2.00	33.01	PASS
		50	0		21.43	1.48	22.91	2.00	33.01	PASS
		50	24		21.45	1.48	22.93	2.00	33.01	PASS
		50	49		21.37	1.48	22.85	2.00	33.01	PASS
		100	0	21.30	1.48	22.78	2.00	33.01	PASS	
		1	0	QPSK	23.54	1.48	25.02	2.00	33.01	PASS
		1	49		23.36	1.48	24.84	2.00	33.01	PASS
	1	99	23.38		1.48	24.86	2.00	33.01	PASS	
	50	0	22.17		1.48	23.65	2.00	33.01	PASS	
	50	24	22.14		1.48	23.62	2.00	33.01	PASS	
	50	49	22.05		1.48	23.53	2.00	33.01	PASS	
	100	0	22.12	1.48	23.60	2.00	33.01	PASS		
	1	0	16QAM	22.54	1.48	24.02	2.00	33.01	PASS	
	1	49		22.37	1.48	23.85	2.00	33.01	PASS	
	1	99		22.45	1.48	23.93	2.00	33.01	PASS	
	50	0		21.19	1.48	22.67	2.00	33.01	PASS	
	50	24		21.23	1.48	22.71	2.00	33.01	PASS	
	50	49		21.27	1.48	22.75	2.00	33.01	PASS	
	100	0	21.15	1.48	22.63	2.00	33.01	PASS		
	1	0	QPSK	23.20	1.48	24.68	2.00	33.01	PASS	
	1	49		23.09	1.48	24.57	2.00	33.01	PASS	
	1	99		22.97	1.48	24.45	2.00	33.01	PASS	
	50	0		22.25	1.48	23.73	2.00	33.01	PASS	
	50	24		22.17	1.48	23.65	2.00	33.01	PASS	
	50	49		22.09	1.48	23.57	2.00	33.01	PASS	
	100	0	22.09	1.48	23.57	2.00	33.01	PASS		
	1	0	16QAM	22.22	1.48	23.70	2.00	33.01	PASS	
	1	49		22.20	1.48	23.68	2.00	33.01	PASS	
	1	99		22.11	1.48	23.59	2.00	33.01	PASS	
	50	0		21.34	1.48	22.82	2.00	33.01	PASS	
	50	24		21.20	1.48	22.68	2.00	33.01	PASS	
	50	49		21.18	1.48	22.66	2.00	33.01	PASS	
	100	0	21.16	1.48	22.64	2.00	33.01	PASS		



Radiated Power (ERP) for LTE Band 26 /1.4M											
BW (MHz)	UL Channel	RB Size	RB offset	Modulation	Conduction AVG Power(dBm)	Ant Gain (dBi)	ERP (dBm)	ERP Limit(W)	ERP Limit(dBm)	Verdict	
1.4	Lowest	1	0	QPSK	23.49	-0.98	20.36	7.00	38.45	PASS	
		1	2		23.57	-0.98	20.44	7.00	38.45	PASS	
		1	5		23.46	-0.98	20.33	7.00	38.45	PASS	
		3	0		23.22	-0.98	20.09	7.00	38.45	PASS	
		3	1		23.27	-0.98	20.14	7.00	38.45	PASS	
		3	2		23.24	-0.98	20.11	7.00	38.45	PASS	
		6	0	22.26	-0.98	19.13	7.00	38.45	PASS		
		1	0	16QAM	22.86	-0.98	19.73	7.00	38.45	PASS	
		1	2		22.96	-0.98	19.83	7.00	38.45	PASS	
		1	5		22.90	-0.98	19.77	7.00	38.45	PASS	
		3	0		22.20	-0.98	19.07	7.00	38.45	PASS	
		3	1		22.15	-0.98	19.02	7.00	38.45	PASS	
		3	2		22.27	-0.98	19.14	7.00	38.45	PASS	
		6	0	21.25	-0.98	18.12	7.00	38.45	PASS		
		Middle	QPSK	1	0	23.37	-0.98	20.24	7.00	38.45	PASS
				1	2	23.35	-0.98	20.22	7.00	38.45	PASS
				1	5	23.36	-0.98	20.23	7.00	38.45	PASS
				3	0	23.39	-0.98	20.26	7.00	38.45	PASS
	3			1	23.43	-0.98	20.30	7.00	38.45	PASS	
	3			2	23.48	-0.98	20.35	7.00	38.45	PASS	
	6		0	22.34	-0.98	19.21	7.00	38.45	PASS		
	16QAM		1	0	23.09	-0.98	19.96	7.00	38.45	PASS	
			1	2	23.09	-0.98	19.96	7.00	38.45	PASS	
			1	5	23.03	-0.98	19.90	7.00	38.45	PASS	
			3	0	22.35	-0.98	19.22	7.00	38.45	PASS	
			3	1	22.32	-0.98	19.19	7.00	38.45	PASS	
			3	2	22.38	-0.98	19.25	7.00	38.45	PASS	
	6		0	21.35	-0.98	18.22	7.00	38.45	PASS		
	Highest		QPSK	1	0	23.71	-0.98	20.58	7.00	38.45	PASS
				1	2	23.67	-0.98	20.54	7.00	38.45	PASS
				1	5	23.60	-0.98	20.47	7.00	38.45	PASS
				3	0	23.58	-0.98	20.45	7.00	38.45	PASS
		3		1	23.57	-0.98	20.44	7.00	38.45	PASS	
		3		2	23.48	-0.98	20.35	7.00	38.45	PASS	
		6	0	22.50	-0.98	19.37	7.00	38.45	PASS		
		16QAM	1	0	22.74	-0.98	19.61	7.00	38.45	PASS	
			1	2	22.83	-0.98	19.70	7.00	38.45	PASS	
			1	5	22.83	-0.98	19.70	7.00	38.45	PASS	
			3	0	22.57	-0.98	19.44	7.00	38.45	PASS	
			3	1	22.62	-0.98	19.49	7.00	38.45	PASS	
			3	2	22.59	-0.98	19.46	7.00	38.45	PASS	
		6	0	21.51	-0.98	18.38	7.00	38.45	PASS		



Radiated Power (ERP) for LTE Band 26 /3M										
BW (MHz)	UL Channel	RB Size	RB offset	Modulation	Conduction AVG Power(dBm)	Ant Gain (dBi)	ERP (dBm)	ERP Limit(W)	ERP Limit(dBm)	Verdict
3	Lowest	1	0	QPSK	23.40	-0.98	20.27	7.00	38.45	PASS
		1	7		23.35	-0.98	20.22	7.00	38.45	PASS
		1	14		23.44	-0.98	20.31	7.00	38.45	PASS
		8	0		22.29	-0.98	19.16	7.00	38.45	PASS
		8	4		22.19	-0.98	19.06	7.00	38.45	PASS
		8	7		22.35	-0.98	19.22	7.00	38.45	PASS
		15	0		22.26	-0.98	19.13	7.00	38.45	PASS
		1	0	16QAM	21.89	-0.98	18.76	7.00	38.45	PASS
		1	7		21.99	-0.98	18.86	7.00	38.45	PASS
		1	14		22.06	-0.98	18.93	7.00	38.45	PASS
		8	0		21.38	-0.98	18.25	7.00	38.45	PASS
		8	4		21.41	-0.98	18.28	7.00	38.45	PASS
		8	7		21.29	-0.98	18.16	7.00	38.45	PASS
		15	0		21.14	-0.98	18.01	7.00	38.45	PASS
		Middle	QPSK	1	0	23.26	-0.98	20.13	7.00	38.45
	1			7	23.32	-0.98	20.19	7.00	38.45	PASS
	1			14	23.32	-0.98	20.19	7.00	38.45	PASS
	8			0	22.39	-0.98	19.26	7.00	38.45	PASS
	8			4	22.42	-0.98	19.29	7.00	38.45	PASS
	8			7	22.35	-0.98	19.22	7.00	38.45	PASS
	15			0	22.37	-0.98	19.24	7.00	38.45	PASS
	16QAM		1	0	23.05	-0.98	19.92	7.00	38.45	PASS
			1	7	23.08	-0.98	19.95	7.00	38.45	PASS
			1	14	23.10	-0.98	19.97	7.00	38.45	PASS
			8	0	21.59	-0.98	18.46	7.00	38.45	PASS
			8	4	21.36	-0.98	18.23	7.00	38.45	PASS
			8	7	21.37	-0.98	18.24	7.00	38.45	PASS
			15	0	21.46	-0.98	18.33	7.00	38.45	PASS
			Highest	QPSK	1	0	23.74	-0.98	20.61	7.00
	1	7			23.66	-0.98	20.53	7.00	38.45	PASS
	1	14			23.59	-0.98	20.46	7.00	38.45	PASS
	8	0			22.44	-0.98	19.31	7.00	38.45	PASS
	8	4			22.40	-0.98	19.27	7.00	38.45	PASS
	8	7			22.57	-0.98	19.44	7.00	38.45	PASS
	15	0			22.48	-0.98	19.35	7.00	38.45	PASS
	16QAM	1		0	22.74	-0.98	19.61	7.00	38.45	PASS
1		7		22.74	-0.98	19.61	7.00	38.45	PASS	
1		14		22.75	-0.98	19.62	7.00	38.45	PASS	
8		0		21.37	-0.98	18.24	7.00	38.45	PASS	
8		4		21.46	-0.98	18.33	7.00	38.45	PASS	
8		7		21.41	-0.98	18.28	7.00	38.45	PASS	
15		0		21.50	-0.98	18.37	7.00	38.45	PASS	



Radiated Power (ERP) for LTE Band 26 /5M										
BW (MHz)	UL Channel	RB Size	RB offset	Modulation	Conduction AVG Power(dBm)	Ant Gain (dBi)	ERP (dBm)	ERP Limit(W)	ERP Limit(dBm)	Verdict
5	Lowest	1	0	QPSK	23.15	-0.98	20.02	7.00	38.45	PASS
		1	12		23.22	-0.98	20.09	7.00	38.45	PASS
		1	24		23.19	-0.98	20.06	7.00	38.45	PASS
		12	0		22.22	-0.98	19.09	7.00	38.45	PASS
		12	6		22.34	-0.98	19.21	7.00	38.45	PASS
		12	11		22.25	-0.98	19.12	7.00	38.45	PASS
		25	0	22.49	-0.98	19.36	7.00	38.45	PASS	
		1	0	16QAM	22.24	-0.98	19.11	7.00	38.45	PASS
		1	12		22.26	-0.98	19.13	7.00	38.45	PASS
		1	24		22.20	-0.98	19.07	7.00	38.45	PASS
		12	0		21.29	-0.98	18.16	7.00	38.45	PASS
		12	6		21.23	-0.98	18.10	7.00	38.45	PASS
		12	11		21.22	-0.98	18.09	7.00	38.45	PASS
		25	0	21.39	-0.98	18.26	7.00	38.45	PASS	
		1	0	QPSK	23.54	-0.98	20.41	7.00	38.45	PASS
		1	12		23.51	-0.98	20.38	7.00	38.45	PASS
		1	24		23.56	-0.98	20.43	7.00	38.45	PASS
		12	0		22.39	-0.98	19.26	7.00	38.45	PASS
	12	6	22.41		-0.98	19.28	7.00	38.45	PASS	
	12	11	22.49		-0.98	19.36	7.00	38.45	PASS	
	25	0	22.35	-0.98	19.22	7.00	38.45	PASS		
	1	0	16QAM	22.48	-0.98	19.35	7.00	38.45	PASS	
	1	12		22.51	-0.98	19.38	7.00	38.45	PASS	
	1	24		22.49	-0.98	19.36	7.00	38.45	PASS	
	12	0		21.65	-0.98	18.52	7.00	38.45	PASS	
	12	6		21.37	-0.98	18.24	7.00	38.45	PASS	
	12	11		21.43	-0.98	18.30	7.00	38.45	PASS	
	25	0	21.34	-0.98	18.21	7.00	38.45	PASS		
	1	0	QPSK	23.40	-0.98	20.27	7.00	38.45	PASS	
	1	12		23.51	-0.98	20.38	7.00	38.45	PASS	
	1	24		23.40	-0.98	20.27	7.00	38.45	PASS	
	12	0		22.44	-0.98	19.31	7.00	38.45	PASS	
	12	6		22.48	-0.98	19.35	7.00	38.45	PASS	
	12	11		22.48	-0.98	19.35	7.00	38.45	PASS	
	25	0	22.45	-0.98	19.32	7.00	38.45	PASS		
	1	0	16QAM	21.96	-0.98	18.83	7.00	38.45	PASS	
	1	12		22.18	-0.98	19.05	7.00	38.45	PASS	
	1	24		22.14	-0.98	19.01	7.00	38.45	PASS	
	12	0		21.74	-0.98	18.61	7.00	38.45	PASS	
	12	6		21.52	-0.98	18.39	7.00	38.45	PASS	
	12	11		21.53	-0.98	18.40	7.00	38.45	PASS	
	25	0	21.32	-0.98	18.19	7.00	38.45	PASS		



Radiated Power (ERP) for LTE Band 26 /10M										
BW (MHz)	UL Channel	RB Size	RB offset	Modulation	Conduction AVG Power(dBm)	Ant Gain (dBi)	ERP (dBm)	ERP Limit(W)	ERP Limit(dBm)	Verdict
10	Lowest	1	0	QPSK	23.48	-0.98	20.35	7.00	38.45	PASS
		1	24		23.51	-0.98	20.38	7.00	38.45	PASS
		1	49		23.57	-0.98	20.44	7.00	38.45	PASS
		25	0		22.31	-0.98	19.18	7.00	38.45	PASS
		25	12		22.37	-0.98	19.24	7.00	38.45	PASS
		25	24		22.15	-0.98	19.02	7.00	38.45	PASS
		50	0	22.25	-0.98	19.12	7.00	38.45	PASS	
		1	0	16QAM	21.96	-0.98	18.83	7.00	38.45	PASS
		1	24		22.00	-0.98	18.87	7.00	38.45	PASS
		1	49		22.12	-0.98	18.99	7.00	38.45	PASS
		25	0		21.42	-0.98	18.29	7.00	38.45	PASS
		25	12		21.32	-0.98	18.19	7.00	38.45	PASS
		25	24		21.38	-0.98	18.25	7.00	38.45	PASS
		50	0	21.29	-0.98	18.16	7.00	38.45	PASS	
		1	0	QPSK	23.36	-0.98	20.23	7.00	38.45	PASS
	1	24	23.43		-0.98	20.30	7.00	38.45	PASS	
	1	49	23.52		-0.98	20.39	7.00	38.45	PASS	
	25	0	22.36		-0.98	19.23	7.00	38.45	PASS	
	25	12	22.32		-0.98	19.19	7.00	38.45	PASS	
	25	24	22.44		-0.98	19.31	7.00	38.45	PASS	
	50	0	22.32	-0.98	19.19	7.00	38.45	PASS		
	1	0	16QAM	22.79	-0.98	19.66	7.00	38.45	PASS	
	1	24		22.88	-0.98	19.75	7.00	38.45	PASS	
	1	49		22.96	-0.98	19.83	7.00	38.45	PASS	
	25	0		21.76	-0.98	18.63	7.00	38.45	PASS	
	25	12		21.58	-0.98	18.45	7.00	38.45	PASS	
	25	24		21.61	-0.98	18.48	7.00	38.45	PASS	
	50	0	21.56	-0.98	18.43	7.00	38.45	PASS		
	1	0	QPSK	23.61	-0.98	20.48	7.00	38.45	PASS	
	1	24		23.68	-0.98	20.55	7.00	38.45	PASS	
	1	49		23.59	-0.98	20.46	7.00	38.45	PASS	
	25	0		22.49	-0.98	19.36	7.00	38.45	PASS	
	25	12		22.41	-0.98	19.28	7.00	38.45	PASS	
	25	24		22.58	-0.98	19.45	7.00	38.45	PASS	
	50	0	22.57	-0.98	19.44	7.00	38.45	PASS		
	1	0	16QAM	22.58	-0.98	19.45	7.00	38.45	PASS	
	1	24		22.55	-0.98	19.42	7.00	38.45	PASS	
	1	49		22.62	-0.98	19.49	7.00	38.45	PASS	
	25	0		21.45	-0.98	18.32	7.00	38.45	PASS	
	25	12		21.76	-0.98	18.63	7.00	38.45	PASS	
	25	24		21.55	-0.98	18.42	7.00	38.45	PASS	
	50	0	21.74	-0.98	18.61	7.00	38.45	PASS		



Radiated Power (ERP) for LTE Band 26 /15M										
BW (MHz)	UL Channel	RB Size	RB offset	Modulation	Conduction AVG Power(dBm)	Ant Gain (dBi)	ERP (dBm)	ERP Limit(W)	ERP Limit(dBm)	Verdict
15	Lowest	1	0	QPSK	23.52	-0.98	20.39	7.00	38.45	PASS
		1	24		23.50	-0.98	20.37	7.00	38.45	PASS
		1	49		23.69	-0.98	20.56	7.00	38.45	PASS
		25	0		22.35	-0.98	19.22	7.00	38.45	PASS
		25	12		22.26	-0.98	19.13	7.00	38.45	PASS
		25	24		22.37	-0.98	19.24	7.00	38.45	PASS
		50	0		22.34	-0.98	19.21	7.00	38.45	PASS
		1	0	16QAM	21.96	-0.98	18.83	7.00	38.45	PASS
		1	24		21.97	-0.98	18.84	7.00	38.45	PASS
		1	49		22.19	-0.98	19.06	7.00	38.45	PASS
		25	0		21.32	-0.98	18.19	7.00	38.45	PASS
		25	12		21.38	-0.98	18.25	7.00	38.45	PASS
		25	24		21.72	-0.98	18.59	7.00	38.45	PASS
		50	0		21.39	-0.98	18.26	7.00	38.45	PASS
	1	0	QPSK	23.33	-0.98	20.20	7.00	38.45	PASS	
	1	24		23.46	-0.98	20.33	7.00	38.45	PASS	
	1	49		23.56	-0.98	20.43	7.00	38.45	PASS	
	25	0		22.36	-0.98	19.23	7.00	38.45	PASS	
	25	12		22.33	-0.98	19.20	7.00	38.45	PASS	
	25	24		22.38	-0.98	19.25	7.00	38.45	PASS	
	50	0		22.36	-0.98	19.23	7.00	38.45	PASS	
	1	0	16QAM	22.81	-0.98	19.68	7.00	38.45	PASS	
	1	24		22.86	-0.98	19.73	7.00	38.45	PASS	
	1	49		22.92	-0.98	19.79	7.00	38.45	PASS	
	25	0		21.48	-0.98	18.35	7.00	38.45	PASS	
	25	12		21.37	-0.98	18.24	7.00	38.45	PASS	
	25	24		21.40	-0.98	18.27	7.00	38.45	PASS	
	50	0		21.41	-0.98	18.28	7.00	38.45	PASS	
	1	0	QPSK	23.53	-0.98	20.40	7.00	38.45	PASS	
	1	24		23.75	-0.98	20.62	7.00	38.45	PASS	
	1	49		23.61	-0.98	20.48	7.00	38.45	PASS	
	25	0		22.49	-0.98	19.36	7.00	38.45	PASS	
	25	12		22.48	-0.98	19.35	7.00	38.45	PASS	
	25	24		22.42	-0.98	19.29	7.00	38.45	PASS	
	50	0		22.46	-0.98	19.33	7.00	38.45	PASS	
	1	0	16QAM	22.24	-0.98	19.11	7.00	38.45	PASS	
1	24	22.31		-0.98	19.18	7.00	38.45	PASS		
1	49	22.36		-0.98	19.23	7.00	38.45	PASS		
25	0	21.43		-0.98	18.30	7.00	38.45	PASS		
25	12	21.41		-0.98	18.28	7.00	38.45	PASS		
25	24	21.63		-0.98	18.50	7.00	38.45	PASS		
50	0	21.41		-0.98	18.28	7.00	38.45	PASS		



Radiated Power (ERP) for LTE Band 26 /1.4M											
BW (MHz)	UL Channel	RB Size	RB offset	Modulation	Conduction AVG Power(dBm)	Ant Gain (dBi)	ERP (dBm)	ERP Limit(W)	ERP Limit(dBm)	Verdict	
1.4	Lowest	1	0	QPSK	23.59	-0.98	20.46	100.00	50.00	PASS	
		1	2		23.65	-0.98	20.52	100.00	50.00	PASS	
		1	5		23.62	-0.98	20.49	100.00	50.00	PASS	
		3	0		23.49	-0.98	20.36	100.00	50.00	PASS	
		3	1		23.43	-0.98	20.30	100.00	50.00	PASS	
		3	2		23.52	-0.98	20.39	100.00	50.00	PASS	
		6	0	22.32	-0.98	19.19	100.00	50.00	PASS		
		1	0	16QAM	23.23	-0.98	20.10	100.00	50.00	PASS	
		1	2		23.22	-0.98	20.09	100.00	50.00	PASS	
		1	5		23.20	-0.98	20.07	100.00	50.00	PASS	
		3	0		22.33	-0.98	19.20	100.00	50.00	PASS	
		3	1		22.27	-0.98	19.14	100.00	50.00	PASS	
		3	2		22.34	-0.98	19.21	100.00	50.00	PASS	
		6	0	21.45	-0.98	18.32	100.00	50.00	PASS		
		Middle	QPSK	1	0	23.29	-0.98	20.16	100.00	50.00	PASS
				1	2	23.20	-0.98	20.07	100.00	50.00	PASS
				1	5	23.16	-0.98	20.03	100.00	50.00	PASS
				3	0	23.39	-0.98	20.26	100.00	50.00	PASS
	3			1	23.46	-0.98	20.33	100.00	50.00	PASS	
	3			2	23.41	-0.98	20.28	100.00	50.00	PASS	
	6		0	22.27	-0.98	19.14	100.00	50.00	PASS		
	16QAM		1	0	23.12	-0.98	19.99	100.00	50.00	PASS	
			1	2	23.11	-0.98	19.98	100.00	50.00	PASS	
			1	5	23.08	-0.98	19.95	100.00	50.00	PASS	
			3	0	22.20	-0.98	19.07	100.00	50.00	PASS	
			3	1	22.20	-0.98	19.07	100.00	50.00	PASS	
			3	2	22.20	-0.98	19.07	100.00	50.00	PASS	
	6		0	21.60	-0.98	18.47	100.00	50.00	PASS		
	Highest		QPSK	1	0	23.56	-0.98	20.43	100.00	50.00	PASS
				1	2	23.58	-0.98	20.45	100.00	50.00	PASS
				1	5	23.52	-0.98	20.39	100.00	50.00	PASS
				3	0	23.35	-0.98	20.22	100.00	50.00	PASS
		3		1	23.33	-0.98	20.20	100.00	50.00	PASS	
		3		2	23.38	-0.98	20.25	100.00	50.00	PASS	
		6	0	22.47	-0.98	19.34	100.00	50.00	PASS		
		16QAM	1	0	22.71	-0.98	19.58	100.00	50.00	PASS	
1			2	22.78	-0.98	19.65	100.00	50.00	PASS		
1			5	22.71	-0.98	19.58	100.00	50.00	PASS		
3			0	22.48	-0.98	19.35	100.00	50.00	PASS		
3			1	22.46	-0.98	19.33	100.00	50.00	PASS		
3			2	22.48	-0.98	19.35	100.00	50.00	PASS		
6		0	21.47	-0.98	18.34	100.00	50.00	PASS			



Radiated Power (ERP) for LTE Band 26 /3M										
BW (MHz)	UL Channel	RB Size	RB offset	Modulation	Conduction AVG Power(dBm)	Ant Gain (dBi)	ERP (dBm)	ERP Limit(W)	ERP Limit(dBm)	Verdict
3	Lowest	1	0	QPSK	23.43	-0.98	20.30	100.00	50.00	PASS
		1	7		23.38	-0.98	20.25	100.00	50.00	PASS
		1	14		23.29	-0.98	20.16	100.00	50.00	PASS
		8	0		22.26	-0.98	19.13	100.00	50.00	PASS
		8	4		22.28	-0.98	19.15	100.00	50.00	PASS
		8	7		22.16	-0.98	19.03	100.00	50.00	PASS
		15	0		22.43	-0.98	19.30	100.00	50.00	PASS
		1	0	16QAM	22.06	-0.98	18.93	100.00	50.00	PASS
		1	7		22.03	-0.98	18.90	100.00	50.00	PASS
		1	14		22.08	-0.98	18.95	100.00	50.00	PASS
		8	0		21.75	-0.98	18.62	100.00	50.00	PASS
		8	4		21.66	-0.98	18.53	100.00	50.00	PASS
		8	7		21.35	-0.98	18.22	100.00	50.00	PASS
		15	0		21.53	-0.98	18.40	100.00	50.00	PASS
		1	0	QPSK	23.13	-0.98	20.00	100.00	50.00	PASS
	1	7	23.27		-0.98	20.14	100.00	50.00	PASS	
	1	14	23.18		-0.98	20.05	100.00	50.00	PASS	
	8	0	22.34		-0.98	19.21	100.00	50.00	PASS	
	8	4	22.27		-0.98	19.14	100.00	50.00	PASS	
	8	7	22.24		-0.98	19.11	100.00	50.00	PASS	
	15	0	22.22		-0.98	19.09	100.00	50.00	PASS	
	1	0	16QAM	23.16	-0.98	20.03	100.00	50.00	PASS	
	1	7		23.16	-0.98	20.03	100.00	50.00	PASS	
	1	14		23.08	-0.98	19.95	100.00	50.00	PASS	
	8	0		21.57	-0.98	18.44	100.00	50.00	PASS	
	8	4		21.52	-0.98	18.39	100.00	50.00	PASS	
	8	7		21.53	-0.98	18.40	100.00	50.00	PASS	
	15	0		21.60	-0.98	18.47	100.00	50.00	PASS	
	1	0	QPSK	23.55	-0.98	20.42	100.00	50.00	PASS	
	1	7		23.59	-0.98	20.46	100.00	50.00	PASS	
	1	14		23.55	-0.98	20.42	100.00	50.00	PASS	
	8	0		22.30	-0.98	19.17	100.00	50.00	PASS	
	8	4		22.36	-0.98	19.23	100.00	50.00	PASS	
	8	7		22.27	-0.98	19.14	100.00	50.00	PASS	
	15	0		22.37	-0.98	19.24	100.00	50.00	PASS	
	1	0	16QAM	22.74	-0.98	19.61	100.00	50.00	PASS	
	1	7		22.84	-0.98	19.71	100.00	50.00	PASS	
	1	14		22.68	-0.98	19.55	100.00	50.00	PASS	
	8	0		21.26	-0.98	18.13	100.00	50.00	PASS	
	8	4		21.32	-0.98	18.19	100.00	50.00	PASS	
	8	7		21.30	-0.98	18.17	100.00	50.00	PASS	
	15	0		21.36	-0.98	18.23	100.00	50.00	PASS	



Radiated Power (ERP) for LTE Band 26 /5M										
BW (MHz)	UL Channel	RB Size	RB offset	Modulation	Conduction AVG Power(dBm)	Ant Gain (dBi)	ERP (dBm)	ERP Limit(W)	ERP Limit(dBm)	Verdict
5	Lowest	1	0	QPSK	23.49	-0.98	20.36	100.00	50.00	PASS
		1	12		23.35	-0.98	20.22	100.00	50.00	PASS
		1	24		23.49	-0.98	20.36	100.00	50.00	PASS
		12	0		22.34	-0.98	19.21	100.00	50.00	PASS
		12	6		22.28	-0.98	19.15	100.00	50.00	PASS
		12	11		22.24	-0.98	19.11	100.00	50.00	PASS
		25	0		22.40	-0.98	19.27	100.00	50.00	PASS
		1	0	16QAM	22.23	-0.98	19.10	100.00	50.00	PASS
		1	12		22.24	-0.98	19.11	100.00	50.00	PASS
		1	24		22.21	-0.98	19.08	100.00	50.00	PASS
		12	0		21.62	-0.98	18.49	100.00	50.00	PASS
		12	6		21.30	-0.98	18.17	100.00	50.00	PASS
		12	11		21.26	-0.98	18.13	100.00	50.00	PASS
		25	0		21.33	-0.98	18.20	100.00	50.00	PASS
	1	0	QPSK	23.48	-0.98	20.35	100.00	50.00	PASS	
	1	12		23.51	-0.98	20.38	100.00	50.00	PASS	
	1	24		23.44	-0.98	20.31	100.00	50.00	PASS	
	12	0		22.37	-0.98	19.24	100.00	50.00	PASS	
	12	6		22.25	-0.98	19.12	100.00	50.00	PASS	
	12	11		22.33	-0.98	19.20	100.00	50.00	PASS	
	25	0		22.32	-0.98	19.19	100.00	50.00	PASS	
	1	0	16QAM	22.56	-0.98	19.43	100.00	50.00	PASS	
	1	12		22.44	-0.98	19.31	100.00	50.00	PASS	
	1	24		22.34	-0.98	19.21	100.00	50.00	PASS	
	12	0		21.30	-0.98	18.17	100.00	50.00	PASS	
	12	6		21.66	-0.98	18.53	100.00	50.00	PASS	
	12	11		21.31	-0.98	18.18	100.00	50.00	PASS	
	25	0		21.61	-0.98	18.48	100.00	50.00	PASS	
	1	0	QPSK	23.36	-0.98	20.23	100.00	50.00	PASS	
	1	12		23.22	-0.98	20.09	100.00	50.00	PASS	
	1	24		23.22	-0.98	20.09	100.00	50.00	PASS	
	12	0		22.31	-0.98	19.18	100.00	50.00	PASS	
	12	6		22.35	-0.98	19.22	100.00	50.00	PASS	
	12	11		22.30	-0.98	19.17	100.00	50.00	PASS	
	25	0		22.23	-0.98	19.10	100.00	50.00	PASS	
	1	0	16QAM	21.91	-0.98	18.78	100.00	50.00	PASS	
1	12	21.84		-0.98	18.71	100.00	50.00	PASS		
1	24	22.00		-0.98	18.87	100.00	50.00	PASS		
12	0	21.35		-0.98	18.22	100.00	50.00	PASS		
12	6	21.34		-0.98	18.21	100.00	50.00	PASS		
12	11	21.44		-0.98	18.31	100.00	50.00	PASS		
25	0	21.19		-0.98	18.06	100.00	50.00	PASS		



Radiated Power (ERP) for LTE Band 26 /10M										
BW (MHz)	UL Channel	RB Size	RB offset	Modulation	Conduction AVG Power(dBm)	Ant Gain (dBi)	ERP (dBm)	ERP Limit(W)	ERP Limit(dBm)	Verdict
10	Middle	1	0	QPSK	23.67	-0.98	20.54	100.00	50.00	PASS
		1	24		23.45	-0.98	20.32	100.00	50.00	PASS
		1	49		23.39	-0.98	20.26	100.00	50.00	PASS
		25	0		22.32	-0.98	19.19	100.00	50.00	PASS
		25	12		22.24	-0.98	19.11	100.00	50.00	PASS
		25	24		22.29	-0.98	19.16	100.00	50.00	PASS
		50	0	22.37	-0.98	19.24	100.00	50.00	PASS	
		1	0	16QAM	22.01	-0.98	18.88	100.00	50.00	PASS
		1	24		21.97	-0.98	18.84	100.00	50.00	PASS
		1	49		22.02	-0.98	18.89	100.00	50.00	PASS
		25	0		21.32	-0.98	18.19	100.00	50.00	PASS
		25	12		21.56	-0.98	18.43	100.00	50.00	PASS
		25	24		21.22	-0.98	18.09	100.00	50.00	PASS
		50	0		21.64	-0.98	18.51	100.00	50.00	PASS

5.2 PEAK TO AVERAGE RATIO

TEST OVERVIEW

According to §24.232(d), power measurements for transmissions by stations authorized under this section may be made either in accordance with a commission-approved average power technique or in compliance with paragraph (e) of this section. In both instances, equipment employed must be authorized in accordance with the provisions of §24.51. In measuring transmissions in this band using an average power technique, the peak-to-average ratio (PAR) of the transmission may not exceed 13 db.

TEST PROCEDURES

1. The testing follows FCC KDB 971168 v03r01 section.
2. The eut was connected to the peak and av system simulator& spectrum analyzer.
3. Select lowest, middle, and highest channels for each band and different modulation.
4. Set the test probe and measure average power of the spectrum analysis,

TEST SETUP

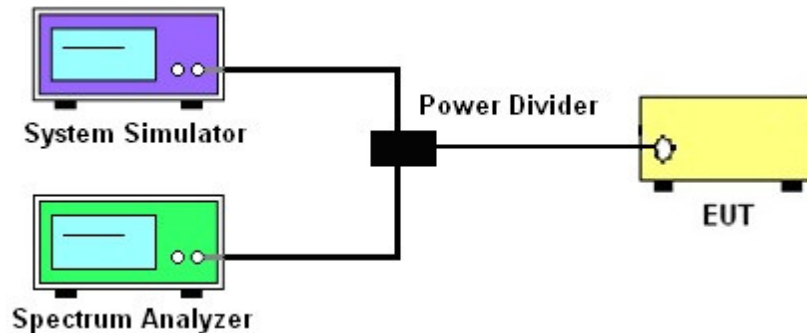

TEST RESULT

Note: The test data please reference to attachment “STS2310308W09_Appendix GSM” , “STS2310308W09_Appendix WCDMA” and “STS2310308W09_Appendix LTE”.

5.3 OCCUPIED BANDWIDTH

TEST OVERVIEW

The occupied bandwidth, that is the frequency bandwidth such that, below its lower and above its upper frequency limits, the mean powers radiated are each equal to 0.5 percent of the total mean power radiated by a given emission shall be measured.

The 26 dB emission bandwidth is defined as the frequency range between two points, one above and one below the carrier frequency, at which the spectral density of the emission is attenuated 26 dB below the maximum in-band spectral density of the modulated signal. Spectral density (power per unit bandwidth) is to be measured with a detector of resolution bandwidth equal to approximately 1.0% of the emission bandwidth.

All modes of operation were investigated and the worst case configuration results are reported in this section.

TEST PROCEDURE

1. The signal analyzer's automatic bandwidth measurement capability was used to perform the 99% occupied bandwidth and the 26dB bandwidth. The bandwidth measurement was not influenced by any intermediate power nulls in the fundamental emission.
2. RBW = 1 – 5% of the expected OBW
3. VBW \geq 3 x RBW
4. Detector = Peak
5. Trace mode = max hold
6. Sweep = auto couple
7. The trace was allowed to stabilize
8. If necessary, steps 2 – 7 were repeated after changing the RBW such that it would be within 1 – 5% of the 99% occupied bandwidth observed in Step 7

TEST SETUP

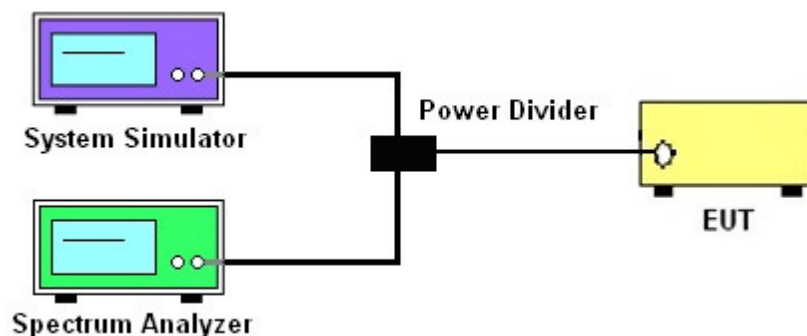

TEST RESULT

Note: The test data please reference to attachment “STS2310308W09_Appendix GSM” , “STS2310308W09_Appendix WCDMA” and “STS2310308W09_Appendix LTE”.

5.4 FREQUENCY STABILITY

TEST OVERVIEW

Frequency stability testing is performed in accordance with the guidelines of ANSI C63.26 2015.

The frequency stability of the transmitter is measured by:

- a.) Temperature: The temperature is varied from -30°C to $+50^{\circ}\text{C}$ in 10°C increments using an environmental chamber.
- b.) Primary Supply Voltage: The primary supply voltage is varied from 85% to 115% of the nominal value for non hand-carried battery and AC powered equipment. For hand-carried, battery-powered equipment, primary supply voltage is reduced to the battery operating end point which shall be specified by the manufacturer.

For Part 22, the frequency stability of the transmitter shall be maintained within $\pm 0.00025\%$ (± 2.5 ppm) of the center frequency. For Part 24 the frequency stability shall be sufficient to ensure that the fundamental emission stays within the authorized frequency block.

TEST PROCEDURE

Temperature Variation

1. The testing follows FCC KDB 971168 D01 section 9.0
2. The EUT was set up in the thermal chamber and connected with the system simulator.
3. With power OFF, the temperature was decreased to -30°C and the EUT was stabilized before testing. Power was applied and the maximum change in frequency was recorded within one minute.
4. With power OFF, the temperature was raised in 10°C steps up to 50°C . The EUT was stabilized at each step for at least half an hour. Power was applied and the maximum frequency change was recorded within one minute.

Voltage Variation

1. The testing follows FCC KDB 971168 D01 Section 9.0.
2. The EUT was placed in a temperature chamber at $25 \pm 5^{\circ}\text{C}$ and connected with the system simulator.
3. The power supply voltage to the EUT was varied from 85% to 115% of the nominal value measured at the input to the EUT.
4. The variation in frequency was measured for the worst case.

TEST SETUP

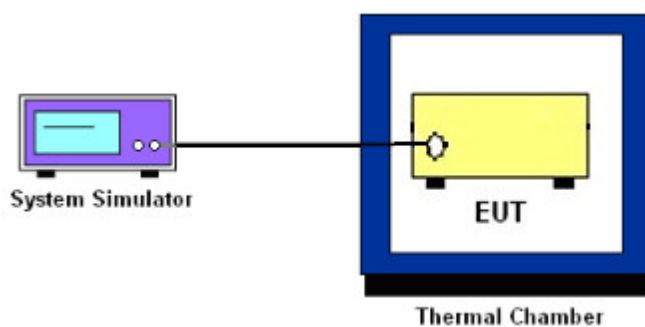

TEST RESULT

GPRS 850 /836.6MHz					
Temperature (°C)	Voltage	Freq. Dev.	Freq. Dev.	Limit	Result
	(Volt)	(Hz)	(ppm)		
50	Normal Voltage	33.20	0.040	2.5ppm	PASS
40		17.22	0.021		
30		16.71	0.020		
20		31.37	0.037		
10		14.52	0.017		
0		26.67	0.032		
-10		22.22	0.027		
-20		34.81	0.042		
-30		20.85	0.025		
20		Maximum Voltage	31.68		
20	BEP	30.10	0.036		

EGPRS 850 /836.6MHz					
Temperature (°C)	Voltage	Freq. Dev.	Freq. Dev.	Limit	Result
	(Volt)	(Hz)	(ppm)		
50	Normal Voltage	22.88	0.027	2.5ppm	PASS
40		28.26	0.034		
30		23.31	0.028		
20		19.04	0.023		
10		21.90	0.026		
0		34.57	0.041		
-10		30.83	0.037		
-20		18.35	0.022		
-30		32.98	0.039		
20		Maximum Voltage	13.00		
20	BEP	30.76	0.037		

GPRS 1900 / 1880MHz					
Temperature (°C)	Voltage	Freq. Dev.	Freq. Dev.	Limit	Result
	(Volt)	(Hz)	(ppm)		
50	Normal Voltage	31.86	0.017	Within Authorized Band	PASS
40		15.39	0.008		
30		26.03	0.014		
20		33.64	0.018		
10		16.47	0.009		
0		25.86	0.014		
-10		16.86	0.009		
-20		29.63	0.016		
-30		23.44	0.012		
20		Maximum Voltage	30.92		
20	BEP	22.82	0.012		

EGPRS 1900 / 1880MHz					
Temperature (°C)	Voltage	Freq. Dev.	Freq. Dev.	Limit	Result
	(Volt)	(Hz)	(ppm)		
50	Normal Voltage	34.64	0.018	Within Authorized	PASS



40		27.77	0.015	Band		
30		18.79	0.010			
20		29.24	0.016			
10		23.40	0.012			
0		34.47	0.018			
-10		12.78	0.007			
-20		28.83	0.015			
-30		23.99	0.013			
20		Maximum Voltage	22.56			0.012
20		BEP	11.69			0.006

UMTS Band 2 /1880MHz					
Temperature (°C)	Voltage	Freq. Dev.	Freq. Dev.	Limit	Result
	(Volt)	(Hz)	(ppm)		
50	Normal Voltage	33.52	0.018	Within Authorized Band	PASS
40		21.28	0.011		
30		27.12	0.014		
20		29.96	0.016		
10		33.27	0.018		
0		14.48	0.008		
-10		34.04	0.018		
-20		36.22	0.019		
-30		34.79	0.019		
20		Maximum Voltage	29.62		
20	BEP	29.24	0.016		

HSDPA Band 2 /1880MHz					
Temperature (°C)	Voltage	Freq. Dev.	Freq. Dev.	Limit	Result
	(Volt)	(Hz)	(ppm)		
50	Normal Voltage	15.22	0.008	Within Authorized Band	PASS
40		20.67	0.011		
30		20.34	0.011		
20		17.95	0.010		
10		15.05	0.008		
0		35.07	0.019		
-10		31.28	0.017		
-20		15.85	0.008		
-30		11.79	0.006		
20		Maximum Voltage	14.80		
20	BEP	15.79	0.008		

HSUPA Band 2 /1880MHz					
Temperature (°C)	Voltage	Freq. Dev.	Freq. Dev.	Limit	Result
	(Volt)	(Hz)	(ppm)		
50	Normal Voltage	29.23	0.016	Within Authorized Band	PASS
40		14.30	0.008		
30		29.53	0.016		
20		19.75	0.011		



10		36.32	0.019		
0		13.83	0.007		
-10		28.01	0.015		
-20		24.57	0.013		
-30		17.80	0.009		
20	Maximum Voltage	20.77	0.011		
20	BEP	33.05	0.018		

UMTS Band 5 / 836.4MHz					
Temperature (°C)	Voltage	Freq. Dev.	Freq. Dev.	Limit	Result
	(Volt)	(Hz)	(ppm)		
50	Normal Voltage	33.60	0.040	2.5ppm	PASS
40		28.15	0.034		
30		24.69	0.030		
20		18.18	0.022		
10		16.19	0.019		
0		17.57	0.021		
-10		20.62	0.025		
-20		18.21	0.022		
-30		18.64	0.022		
20		Maximum Voltage	25.45		
20	BEP	28.34	0.034		

HSDPA Band 5 / 836.4MHz					
Temperature (°C)	Voltage	Freq. Dev.	Freq. Dev.	Limit	Result
	(Volt)		(ppm)		
50	Normal Voltage	19.05	0.023	2.5ppm	PASS
40		16.23	0.019		
30		12.21	0.015		
20		20.42	0.024		
10		28.34	0.034		
0		17.04	0.020		
-10		28.33	0.034		
-20		14.26	0.017		
-30		29.89	0.036		
20		Maximum Voltage	16.28		
20	BEP	22.68	0.027		

HSUPA Band 5 / 836.4MHz					
Temperature (°C)	Voltage	Freq. Dev.	Freq. Dev.	Limit	Result
	(Volt)	(Hz)	(ppm)		
50	Normal Voltage	18.52	0.022	2.5ppm	PASS
40		23.29	0.028		
30		30.45	0.036		
20		30.27	0.036		
10		15.40	0.018		
0		21.33	0.025		
-10		21.60	0.026		



-20		35.14	0.042		
-30		29.90	0.036		
20	Maximum Voltage	21.30	0.025		
20	BEP	16.78	0.020		

LTE Band 2 (QPSK) / 1880MHz / BW10M					
Temperature (°C)	Voltage	Freq. Dev.	Freq. Dev.	Limit	Result
	(Volt)	(Hz)	(ppm)		
50	Normal Voltage	16.62	0.009	2.5ppm	PASS
40		12.79	0.007		
30		25.16	0.013		
20		30.06	0.016		
10		26.27	0.014		
0		33.29	0.018		
-10		22.19	0.012		
-20		14.26	0.008		
-30		18.67	0.010		
20		Maximum Voltage	11.70		
20	BEP	16.24	0.009		

LTE Band 2 (QPSK) / 1880MHz / BW20M					
Temperature (°C)	Voltage	Freq. Dev.	Freq. Dev.	Limit	Result
	(Volt)	(Hz)	(ppm)		
50	Normal Voltage	35.57	0.019	2.5ppm	PASS
40		35.17	0.019		
30		30.29	0.016		
20		20.64	0.011		
10		16.19	0.009		
0		30.10	0.016		
-10		13.05	0.007		
-20		34.33	0.018		
-30		24.63	0.013		
20		Maximum Voltage	32.40		
20	BEP	28.95	0.015		

LTE Band 4 (QPSK) / 1733MHz / BW10M					
Temperature (°C)	Voltage	Freq. Dev.	Freq. Dev.	Limit	Result
	(Volt)	(Hz)	(ppm)		
50	Normal Voltage	18.43	0.011	2.5ppm	PASS
40		25.22	0.015		
30		21.24	0.012		
20		16.65	0.010		
10		23.65	0.014		
0		36.25	0.021		
-10		22.85	0.013		
-20		16.90	0.010		
-30		31.85	0.018		
20		Maximum	34.65		



	Voltage				
20	BEP	35.35	0.020		

LTE Band 4 (QPSK) / 1733MHz / BW20M					
Temperature (°C)	Voltage	Freq. Dev.	Freq. Dev.	Limit	Result
	(Volt)	(Hz)	(ppm)		
50	Normal Voltage	16.85	0.010	2.5ppm	PASS
40		23.26	0.013		
30		11.75	0.007		
20		18.15	0.010		
10		18.36	0.011		
0		29.60	0.017		
-10		34.64	0.020		
-20		21.18	0.012		
-30		11.86	0.007		
20		Maximum Voltage	14.01		
20	BEP	14.86	0.009		

LTE Band 5 (QPSK) / 836.5MHz / BW5M					
Temperature (°C)	Voltage	Freq. Dev.	Freq. Dev.	Limit	Result
	(Volt)	(Hz)	(ppm)		
50	Normal Voltage	32.18	0.045	2.5ppm	PASS
40		17.45	0.025		
30		13.02	0.018		
20		19.05	0.027		
10		16.41	0.023		
0		11.73	0.017		
-10		28.28	0.004		
-20		14.36	0.020		
-30		25.71	0.036		
20		Maximum Voltage	23.86		
20	BEP	19.86	0.028		

LTE Band 5 (QPSK) / 836.5MHz / BW10M					
Temperature (°C)	Voltage	Freq. Dev.	Freq. Dev.	Limit	Result
	(Volt)	(Hz)	(ppm)		
50	Normal Voltage	20.05	0.028	2.5ppm	PASS
40		33.92	0.048		
30		14.69	0.021		
20		34.01	0.048		
10		28.88	0.041		
0		27.98	0.039		
-10		21.40	0.003		
-20		27.10	0.038		
-30		11.86	0.017		
20		Maximum Voltage	15.18		
20	BEP	12.39	0.017		



LTE Band 7 (QPSK) / 2535MHz / BW10M					
Temperature (°C)	Voltage	Freq. Dev.	Freq. Dev.	Limit	Result
	(Volt)	(Hz)	(ppm)		
50	Normal Voltage	18.77	0.007	2.5ppm	PASS
40		19.67	0.008		
30		23.79	0.009		
20		30.72	0.012		
10		22.01	0.009		
0		18.35	0.007		
-10		16.56	0.007		
-20		28.94	0.011		
-30		19.59	0.008		
20		Maximum Voltage	30.09		
20	BEP	15.27	0.006		

LTE Band 7 (QPSK) / 2535MHz / BW20M					
Temperature (°C)	Voltage	Freq. Dev.	Freq. Dev.	Limit	Result
	(Volt)	(Hz)	(ppm)		
50	Normal Voltage	25.13	0.010	2.5ppm	PASS
40		21.80	0.009		
30		24.74	0.010		
20		28.14	0.011		
10		24.46	0.010		
0		21.21	0.008		
-10		16.66	0.007		
-20		15.81	0.006		
-30		35.70	0.014		
20		Maximum Voltage	35.49		
20	BEP	16.79	0.007		

LTE Band 12 (QPSK) / 707.5MHz / BW5M					
Temperature (°C)	Voltage	Freq. Dev.	Freq. Dev.	Limit	Result
	(Volt)	(Hz)	(ppm)		
50	Normal Voltage	23.62	0.033	2.5ppm	PASS
40		11.62	0.016		
30		36.06	0.051		
20		24.90	0.035		
10		33.30	0.047		
0		25.89	0.036		
-10		19.43	0.003		
-20		14.54	0.020		
-30		24.31	0.034		
20		Maximum Voltage	15.51		
20	BEP	16.89	0.024		

LTE Band 12 (QPSK) / 707.5MHz / BW10M					
Temperature (°C)	Voltage	Freq. Dev.	Freq. Dev.	Limit	Result



	(Volt)	(Hz)	(ppm)		
50	Normal Voltage	28.90	0.041	2.5ppm	PASS
40		20.94	0.029		
30		28.67	0.040		
20		33.08	0.047		
10		12.22	0.017		
0		21.09	0.030		
-10		30.56	0.004		
-20		15.08	0.021		
-30		19.68	0.028		
20		Maximum Voltage	35.05		
20	BEP	32.07	0.045		

LTE Band 17 (QPSK) / 710MHz / BW5M					
Temperature (°C)	Voltage	Freq. Dev.	Freq. Dev.	Limit	Result
	(Volt)	(Hz)	(ppm)		
50	Normal Voltage	16.94	0.024	2.5ppm	PASS
40		26.42	0.037		
30		19.83	0.028		
20		27.09	0.038		
10		12.53	0.018		
0		18.36	0.026		
-10		17.10	0.002		
-20		20.91	0.029		
-30		23.47	0.033		
20		Maximum Voltage	20.51		
20	BEP	21.35	0.030		

LTE Band 17 (QPSK) / 710MHz / BW10M					
Temperature (°C)	Voltage	Freq. Dev.	Freq. Dev.	Limit	Result
	(Volt)	(Hz)	(ppm)		
50	Normal Voltage	15.48	0.022	2.5ppm	PASS
40		18.95	0.027		
30		14.59	0.021		
20		25.52	0.036		
10		35.12	0.049		
0		27.40	0.039		
-10		15.92	0.002		
-20		30.19	0.043		
-30		34.35	0.048		
20		Maximum Voltage	20.36		
20	BEP	17.49	0.025		

LTE Band 25 (QPSK) / 1882.5MHz / BW10M					
Temperature (°C)	Voltage	Freq. Dev.	Freq. Dev.	Limit	Result
	(Volt)	(Hz)	(ppm)		
50	Normal Voltage	35.08	0.019	2.5ppm	PASS
40		13.94	0.007		



30		12.12	0.006		
20		17.97	0.010		
10		23.50	0.013		
0		33.11	0.018		
-10		32.66	0.017		
-20		25.80	0.014		
-30		13.49	0.007		
20	Maximum Voltage	36.00	0.019		
20	BEP	34.29	0.018		

LTE Band 25 (QPSK) / 1882.5MHz / BW20M					
Temperature (°C)	Voltage	Freq. Dev.	Freq. Dev.	Limit	Result
	(Volt)	(Hz)	(ppm)		
50	Normal Voltage	29.26	0.016	2.5ppm	PASS
40		17.94	0.010		
30		15.95	0.008		
20		31.67	0.017		
10		14.26	0.008		
0		33.18	0.018		
-10		25.07	0.013		
-20		16.83	0.009		
-30		15.68	0.008		
20	Maximum Voltage	25.99	0.014		
20	BEP	22.12	0.012		

LTE Band 26 (QPSK) / 836.5MHz / BW10M					
Temperature (°C)	Voltage	Freq. Dev.	Freq. Dev.	Limit	Result
	(Volt)	(Hz)	(ppm)		
50	Normal Voltage	12.13	0.007	2.5ppm	PASS
40		33.06	0.019		
30		31.22	0.018		
20		29.72	0.017		
10		16.33	0.009		
0		28.87	0.017		
-10		18.58	0.011		
-20		18.91	0.011		
-30		17.35	0.010		
20	Maximum Voltage	36.14	0.021		
20	BEP	12.01	0.007		

LTE Band 26 (QPSK) / 836.5MHz / BW20M					
Temperature (°C)	Voltage	Freq. Dev.	Freq. Dev.	Limit	Result
	(Volt)	(Hz)	(ppm)		
50	Normal Voltage	21.67	0.013	2.5ppm	PASS
40		16.65	0.010		
30		15.27	0.009		
20		15.94	0.009		
10		27.19	0.016		



0		22.80	0.013		
-10		13.80	0.008		
-20		32.09	0.019		
-30		20.30	0.012		
20	Maximum Voltage	28.77	0.017		
20	BEP	21.33	0.012		

LTE Band 26 (QPSK) / 819MHz / BW5M					
Temperature (°C)	Voltage	Freq. Dev.	Freq. Dev.	Limit	Result
	(Volt)	(Hz)	(ppm)		
50	Normal Voltage	25.32	0.015	2.5ppm	PASS
40		22.05	0.013		
30		34.84	0.020		
20		27.52	0.016		
10		20.32	0.012		
0		16.81	0.010		
-10		24.22	0.014		
-20		11.73	0.007		
-30		12.01	0.007		
20		Maximum Voltage	30.83		
20	BEP	17.06	0.010		

LTE Band 26 (QPSK) / 819MHz / BW10M					
Temperature (°C)	Voltage	Freq. Dev.	Freq. Dev.	Limit	Result
	(Volt)	(Hz)	(ppm)		
50	Normal Voltage	21.66	0.012	2.5ppm	PASS
40		32.76	0.019		
30		22.40	0.013		
20		31.48	0.018		
10		34.51	0.020		
0		29.31	0.017		
-10		36.16	0.021		
-20		15.37	0.009		
-30		30.90	0.018		
20		Maximum Voltage	30.98		
20	BEP	35.43	0.020		

5.5 SPURIOUS EMISSIONS AT ANTENNA TERMINALS TEST OVERVIEW

The power of any emission outside of the authorized operating frequency ranges must be lower than the transmitter power (P) by a factor of at least $43 + 10 \log (P)$ dB.

For Band 7:

The power of any emission outside of the authorized operating frequency ranges must be lower than the transmitter power (P) by a factor of at least $55 + 10 \log (P)$ dB.

It is measured by means of a calibrated spectrum analyzer and scanned from 30 MHz up to a frequency including its 10th harmonic.

TEST PROCEDURE

1. The testing FCC KDB 971168 D01 v03r01 Section 6.0. and ANSI C63.26-2015-Section 5.7.
2. The EUT was connected to the spectrum analyzer and system simulator via a power divider.
3. The RF output of EUT was connected to the spectrum analyzer by an RF cable and attenuator. The path loss was compensated to the results for each measurement.
4. The middle channel for the highest RF power within the transmitting frequency was measured.
5. The conducted spurious emission for the whole frequency range was taken.
6. The RF fundamental frequency should be excluded against the limit line in the operating frequency band.
7. The limit line is derived from $43 + 10\log(P)$ dB below the transmitter power P(Watts)
 $= P(W) - [43 + 10\log(P)]$ (dB)
 $= [30 + 10\log(P)]$ (dBm) - $[43 + 10\log(P)]$ (dB)
 $= -13\text{dBm}$.

TEST SETUP

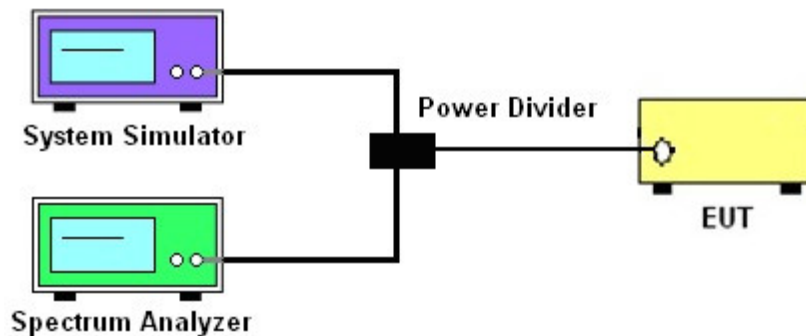

TEST RESULT

Note: The test data please reference to attachment "STS2310308W09_Appendix GSM", "STS2310308W09_Appendix WCDMA" and "STS2310308W09_Appendix LTE".



5.6 BAND EDGE

TEST OVERVIEW

1. §22.917(a)

For operations in the 824 – 849 MHz band, the FCC limit is $43 + 10\log_{10}(P[\text{Watts}])$ dB below the transmitter power $P(\text{Watts})$ in a 100kHz bandwidth. However, in the 1MHz bands immediately outside and adjacent to the licensee's frequency block, a resolution bandwidth of at least one percent of the emission bandwidth of the fundamental emission of the transmitter may be employed.

2. §24.238 (a)

For operations in the 1850-1910 and 1930-1990 MHz band, the FCC limit is $43 + 10\log_{10}(P[\text{Watts}])$ dB below the transmitter power $P(\text{Watts})$ in a 1MHz bandwidth. However, in the 1 MHz bands immediately outside and adjacent to the frequency block a resolution bandwidth of at least one percent of the emission bandwidth of the fundamental emission of the transmitter may be employed

3. §27.53 (h)

For operations in the 1710 – 1755 MHz band, the FCC limit is $43 + 10\log_{10}(P[\text{Watts}])$ dB below the transmitter power $P(\text{Watts})$ in a 1 MHz bandwidth. However, in the 1MHz bands immediately outside and adjacent to the licensee's frequency block, a resolution bandwidth of at least one percent of the emission bandwidth of the fundamental emission of the transmitter may be employed.

4. §27.53(m)(4)

For operations in the 2500 MHz ~ 2570 MHz band this section, the attenuation factor shall be not less than $40 + 10 \log (P)$ dB on all frequencies between the channel edge and 5 megahertz from the channel edge, $43 + 10 \log (P)$ dB on all frequencies between 5 megahertz and X megahertz from the channel edge, and $55 + 10 \log (P)$ dB on all frequencies more than X megahertz from the channel edge, where X is the greater of 6 megahertz or the actual emission bandwidth as defined in paragraph (m)(6) of this section. In addition, the attenuation factor shall not be less that $43 + 10 \log (P)$ dB on all frequencies between 2490.5 MHz and 2496 MHz and $55 + 10 \log (P)$ dB at or below 2490.5 MHz. Mobile Satellite Service licensees operating on frequencies below 2495 MHz may also submit a documented interference complaint against BRS licensees operating on channel BRS Channel 1 on the same terms and conditions as adjacent channel BRS or EBS licensees.

5. §27.53 (g)

For operations in the 698 -746 MHz band, the FCC limit is $43 + 10\log_{10}(P[\text{Watts}])$ dB below the transmitter power $P(\text{Watts})$ in a 100 kHz bandwidth. However, in the 100 kilohertz bands immediately outside and adjacent to a licensee's frequency block, a resolution bandwidth of at least 30 kHz may be employed.

TEST PROCEDURE

1. The testing FCC KDB 971168 D01 v03r01 Section 6.0 and ANSI C63.26-2015-Section 5.7
2. Start and stop frequency were set such that the band edge would be placed in the center of the Plot.
3. The EUT was connected to the spectrum analyzer and system simulator via a power divider.
4. The RF output of EUT was connected to the spectrum analyzer by an RF cable and attenuator. The path loss was compensated to the results for each measurement.
5. The band edges of low and high channels for the highest RF powers were measured.
6. The RF fundamental frequency should be excluded against the limit line in the operating frequency band.

7. The limit line is derived from $43 + 10\log(P)$ dB below the transmitter power P(Watts)

$$= P(W) - [43 + 10\log(P)] \text{ (dB)}$$

$$= [30 + 10\log(P)] \text{ (dBm)} - [43 + 10\log(P)] \text{ (dB)}$$

$$= -13\text{dBm.}$$

Band 7:

$$= P(W) - [55 + 10\log(P)] \text{ (dB)}$$

$$= [30 + 10\log(P)] \text{ (dBm)} - [55 + 10\log(P)] \text{ (dB)}$$

$$= -25\text{dBm.}$$

TEST SETUP

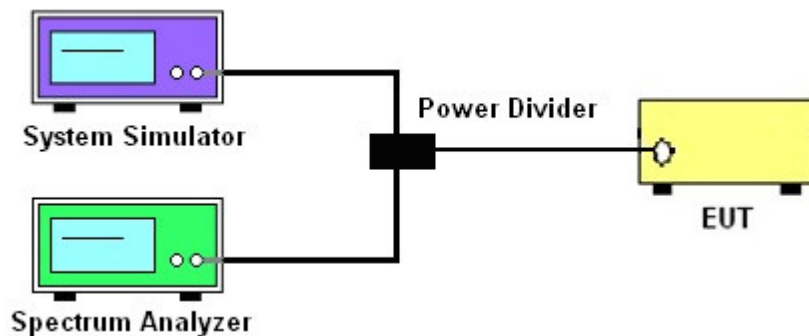

TEST RESULT

Note: The test data please reference to attachment "STS2310308W09_Appendix GSM", "STS2310308W09_Appendix WCDMA" and "STS2310308W09_Appendix LTE".



5.7 FIELD STRENGTH OF SPURIOUS RADIATION MEASUREMENT

TEST OVERVIEW

Radiated spurious emissions measurements are performed using the substitution method described in ANSI C63.26-2015 with the EUT transmitting into an integral antenna. Measurements on signals operating below 1GHz are performed using horizontally and vertically polarized tuned dipole antennas. Measurements on signals operating above 1GHz are performed using vertically and horizontally polarized horn antennas. All measurements are performed as peak measurements while the EUT is operating at maximum power and at the appropriate frequencies.

It is measured by means of a calibrated spectrum analyzer and scanned from 30 MHz up to a frequency including its 10th harmonic.

TEST PROCEDURE

1. The testing FCC KDB 971168 D01 Section 5.8 and ANSI C63.26-2015-Section 5.5.
2. RBW = 100kHz for emissions below 1GHz and 1MHz for emissions above 1GHz
3. VBW \geq 3 x RBW
4. Span = 1.5 times the OBW
5. No. of sweep points > 2 x span/RBW
6. Detector = Peak
7. Trace mode = max hold
8. The trace was allowed to stabilize
9. Effective Isotropic Spurious Radiation was measured by substitution method according to TIA/EIA-603-D. The EUT was replaced by the substitution antenna at same location, and then a known power from S.G. was applied into the dipole antenna through a Tx cable, and then recorded the maximum Analyzer reading through raised and lowered the test antenna.
 $P_{Mea} = S.G \text{ Level} + \text{Ant-Cable loss}$; $\text{Margin} = P_{Mea} - \text{Limit}$.

TEST SETUP

For radiated test from 30MHz to 1GHz

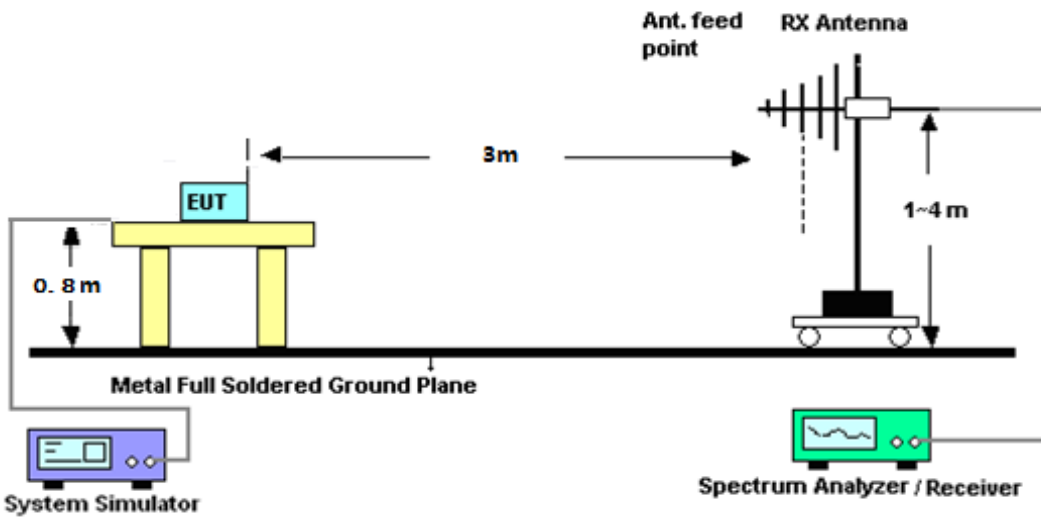

For radiated test from above 1GHz

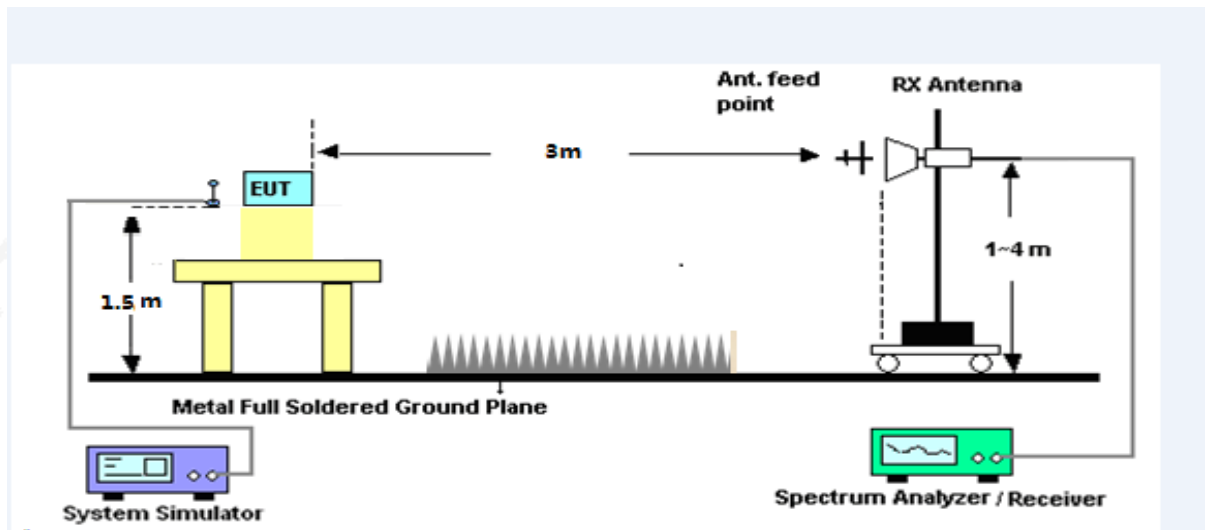

TEST RESULT

- Note:** (1) Spurious emissions which are attenuated by more than 20dB below the permissible value for frequency below 1000MHz.
- (2) Above 3.5GHz amplitude of spurious emissions which are attenuated by more than 20dB below the permissible value
- (3) Test is divided into three directions, X/Y/Z. X pattern for the worst.

GPRS 850: (30-9000)MHz							
The Worst Test Results Channel 128/824.2 MHz							
Frequency(MHz)	S	Ant(dBi)	Loss	PMea	Limit	Margin	Polarity
	G.Lev (dBm)			(dBm)	(dBm)	(dBm)	
1648.30	-41.02	9.40	4.75	-36.37	-13.00	-23.37	H
2472.46	-39.44	10.60	8.39	-37.23	-13.00	-24.23	H
3296.61	-32.17	12.00	11.79	-31.96	-13.00	-18.96	H
1648.30	-44.48	9.40	4.75	-39.83	-13.00	-26.83	V
2472.46	-45.33	10.60	8.39	-43.12	-13.00	-30.12	V
3296.61	-43.82	12.00	11.79	-43.61	-13.00	-30.61	V
The Worst Test Results Channel 190/836.6 MHz							
Frequency(MHz)	S	Ant(dBi)	Loss	PMea	Limit	Margin	Polarity
	G.Lev (dBm)			(dBm)	(dBm)	(dBm)	
1672.95	-41.57	9.50	4.76	-36.83	-13.00	-23.83	H
2509.66	-39.53	10.70	8.40	-37.23	-13.00	-24.23	H
3346.21	-32.03	12.20	11.80	-31.63	-13.00	-18.63	H
1672.95	-44.07	9.40	4.75	-39.42	-13.00	-26.42	V
2509.66	-44.57	10.60	8.39	-42.36	-13.00	-29.36	V
3346.21	-43.83	12.20	11.82	-43.45	-13.00	-30.45	V
The Worst Test Results Channel 251/848.8 MHz							
Frequency(MHz)	S	Ant(dBi)	Loss	PMea	Limit	Margin	Polarity
	G.Lev (dBm)			(dBm)	(dBm)	(dBm)	
1697.38	-40.14	9.60	4.77	-35.31	-13.00	-22.31	H
2546.14	-40.37	10.80	8.50	-38.07	-13.00	-25.07	H
3395.14	-31.52	12.50	11.90	-30.92	-13.00	-17.92	H
1697.38	-44.59	9.60	4.77	-39.76	-13.00	-26.76	V
2546.14	-44.11	10.80	8.50	-41.81	-13.00	-28.81	V
3395.14	-43.53	12.50	11.90	-42.93	-13.00	-29.93	V



EGPRS 850: (30-9000)MHz							
The Worst Test Results Channel 128/824.2 MHz							
Frequency(MHz)	S	Ant(dBi)	Loss	PMea	Limit	Margin	Polarity
	G.Lev (dBm)			(dBm)	(dBm)	(dBm)	
1648.33	-40.61	9.40	4.75	-35.96	-13.00	-22.96	H
2472.22	-40.60	10.60	8.39	-38.39	-13.00	-25.39	H
3296.58	-31.42	12.00	11.79	-31.21	-13.00	-18.21	H
1648.33	-43.30	9.40	4.75	-38.65	-13.00	-25.65	V
2472.22	-44.50	10.60	8.39	-42.29	-13.00	-29.29	V
3296.58	-42.90	12.00	11.79	-42.69	-13.00	-29.69	V
The Worst Test Results Channel 190/836.6 MHz							
Frequency(MHz)	S	Ant(dBi)	Loss	PMea	Limit	Margin	Polarity
	G.Lev (dBm)			(dBm)	(dBm)	(dBm)	
1672.89	-40.57	9.50	4.76	-35.83	-13.00	-22.83	H
2509.72	-39.49	10.70	8.40	-37.19	-13.00	-24.19	H
3346.43	-32.25	12.20	11.80	-31.85	-13.00	-18.85	H
1672.89	-43.55	9.40	4.75	-38.90	-13.00	-25.90	V
2509.72	-44.49	10.60	8.39	-42.28	-13.00	-29.28	V
3346.43	-43.90	12.20	11.82	-43.52	-13.00	-30.52	V
The Worst Test Results Channel 251/848.8 MHz							
Frequency(MHz)	S	Ant(dBi)	Loss	PMea	Limit	Margin	Polarity
	G.Lev (dBm)			(dBm)	(dBm)	(dBm)	
1697.34	-40.30	9.60	4.77	-35.47	-13.00	-22.47	H
2546.36	-39.24	10.80	8.50	-36.94	-13.00	-23.94	H
3395.30	-32.32	12.50	11.90	-31.72	-13.00	-18.72	H
1697.34	-44.45	9.60	4.77	-39.62	-13.00	-26.62	V
2546.36	-45.32	10.80	8.50	-43.02	-13.00	-30.02	V
3395.30	-43.43	12.50	11.90	-42.83	-13.00	-29.83	V



GPRS1900: (30-20000)MHz							
The Worst Test Results for Channel 512/1850.2MHz							
Frequency(MHz)	S	Ant(dBi)	Loss	PMea	Limit	Margin	Polarity
	G.Lev (dBm)			(dBm)	(dBm)	(dBm)	
3700.18	-34.79	12.60	12.93	-35.12	-13.00	-22.12	H
5550.19	-35.06	13.10	17.11	-39.07	-13.00	-26.07	H
7400.87	-32.22	11.50	22.20	-42.92	-13.00	-29.92	H
3700.18	-35.12	12.60	12.93	-35.45	-13.00	-22.45	V
5550.19	-33.99	13.10	17.11	-38.00	-13.00	-25.00	V
7400.87	-32.35	11.50	22.20	-43.05	-13.00	-30.05	V
The Worst Test Results for Channel 661/1880.0MHz							
Frequency(MHz)	S	Ant(dBi)	Loss	PMea	Limit	Margin	Polarity
	G.Lev (dBm)			(dBm)	(dBm)	(dBm)	
3759.81	-34.27	12.60	12.93	-34.60	-13.00	-21.60	H
5640.11	-34.33	13.10	17.11	-38.34	-13.00	-25.34	H
7520.20	-32.26	11.50	22.20	-42.96	-13.00	-29.96	H
3759.81	-34.87	12.60	12.93	-35.20	-13.00	-22.20	V
5640.11	-34.77	13.10	17.11	-38.78	-13.00	-25.78	V
7520.20	-32.02	11.50	22.20	-42.72	-13.00	-29.72	V
The Worst Test Results for Channel 810/1909.8MHz							
Frequency(MHz)	S	Ant(dBi)	Loss	PMea	Limit	Margin	Polarity
	G.Lev (dBm)			(dBm)	(dBm)	(dBm)	
3819.58	-33.52	12.60	12.93	-33.85	-13.00	-20.85	H
5729.44	-34.70	13.10	17.11	-38.71	-13.00	-25.71	H
7638.95	-33.58	11.50	22.20	-44.28	-13.00	-31.28	H
3819.58	-35.30	12.60	12.93	-35.63	-13.00	-22.63	V
5729.44	-34.93	13.10	17.11	-38.94	-13.00	-25.94	V
7638.95	-32.41	11.50	22.20	-43.11	-13.00	-30.11	V



EGPRS 1900: (30-20000)MHz							
The Worst Test Results for Channel 512/1850.2MHz							
Frequency(MHz)	S	Ant(dBi)	Loss	PMea	Limit	Margin	Polarity
	G.Lev (dBm)			(dBm)	(dBm)	(dBm)	
3700.09	-33.46	12.60	12.93	-33.79	-13.00	-20.79	H
5550.39	-35.43	13.10	17.11	-39.44	-13.00	-26.44	H
7400.56	-33.01	11.50	22.20	-43.71	-13.00	-30.71	H
3700.09	-35.22	12.60	12.93	-35.55	-13.00	-22.55	V
5550.39	-33.76	13.10	17.11	-37.77	-13.00	-24.77	V
7400.56	-32.87	11.50	22.20	-43.57	-13.00	-30.57	V
The Worst Test Results for Channel 661/1880.0MHz							
Frequency(MHz)	S	Ant(dBi)	Loss	PMea	Limit	Margin	Polarity
	G.Lev (dBm)			(dBm)	(dBm)	(dBm)	
3760.17	-34.85	12.60	12.93	-35.18	-13.00	-22.18	H
5639.90	-34.98	13.10	17.11	-38.99	-13.00	-25.99	H
7520.10	-32.47	11.50	22.20	-43.17	-13.00	-30.17	H
3760.17	-35.58	12.60	12.93	-35.91	-13.00	-22.91	V
5639.90	-34.07	13.10	17.11	-38.08	-13.00	-25.08	V
7520.10	-31.78	11.50	22.20	-42.48	-13.00	-29.48	V
The Worst Test Results for Channel 810/1909.8MHz							
Frequency(MHz)	S	Ant(dBi)	Loss	PMea	Limit	Margin	Polarity
	G.Lev (dBm)			(dBm)	(dBm)	(dBm)	
3819.34	-33.66	12.60	12.93	-33.99	-13.00	-20.99	H
5729.44	-34.47	13.10	17.11	-38.48	-13.00	-25.48	H
7639.21	-32.34	11.50	22.20	-43.04	-13.00	-30.04	H
3819.34	-34.91	12.60	12.93	-35.24	-13.00	-22.24	V
5729.44	-34.76	13.10	17.11	-38.77	-13.00	-25.77	V
7639.21	-32.79	11.50	22.20	-43.49	-13.00	-30.49	V



WCDMA Band 2: (30-20000)MHz							
The Worst Test Results for Channel 9262/1852.4MHz							
Frequency(MHz)	S	Ant(dBi)	Loss	PMea	Limit	Margin	Polarity
	G.Lev (dBm)			(dBm)	(dBm)	(dBm)	
3704.29	-33.91	12.60	12.93	-34.24	-13.00	-21.24	H
5557.62	-34.72	13.10	17.11	-38.73	-13.00	-25.73	H
7409.56	-32.39	11.50	22.20	-43.09	-13.00	-30.09	H
3704.29	-35.48	12.60	12.93	-35.81	-13.00	-22.81	V
5557.62	-34.50	13.10	17.11	-38.51	-13.00	-25.51	V
7409.56	-32.54	11.50	22.20	-43.24	-13.00	-30.24	V
The Worst Test Results for Channel 9400/1880MHz							
Frequency(MHz)	S	Ant(dBi)	Loss	PMea	Limit	Margin	Polarity
	G.Lev (dBm)			(dBm)	(dBm)	(dBm)	
3759.92	-33.86	12.60	12.93	-34.19	-13.00	-21.19	H
5640.28	-34.54	13.10	17.11	-38.55	-13.00	-25.55	H
7519.84	-33.24	11.50	22.20	-43.94	-13.00	-30.94	H
3759.92	-34.57	12.60	12.93	-34.90	-13.00	-21.90	V
5640.28	-34.42	13.10	17.11	-38.43	-13.00	-25.43	V
7519.84	-32.14	11.50	22.20	-42.84	-13.00	-29.84	V
The Worst Test Results for Channel 9538/1907.6MHz							
Frequency(MHz)	S	Ant(dBi)	Loss	PMea	Limit	Margin	Polarity
	G.Lev (dBm)			(dBm)	(dBm)	(dBm)	
3815.37	-33.52	12.60	12.93	-33.85	-13.00	-20.85	H
5722.57	-34.79	13.10	17.11	-38.80	-13.00	-25.80	H
7630.50	-33.55	11.50	22.20	-44.25	-13.00	-31.25	H
3815.37	-35.16	12.60	12.93	-35.49	-13.00	-22.49	V
5722.57	-34.10	13.10	17.11	-38.11	-13.00	-25.11	V
7630.50	-32.02	11.50	22.20	-42.72	-13.00	-29.72	V



HSUPA Band 2: (30-20000)MHz							
The Worst Test Results for Channel 9262/1852.4MHz							
Frequency(MHz)	S	Ant(dBi)	Loss	PMea	Limit	Margin	Polarity
	G.Lev (dBm)			(dBm)	(dBm)	(dBm)	
3704.40	-34.72	12.60	12.93	-35.05	-13.00	-22.05	H
5557.64	-34.80	13.10	17.11	-38.81	-13.00	-25.81	H
7409.61	-33.62	11.50	22.20	-44.32	-13.00	-31.32	H
3704.40	-35.30	12.60	12.93	-35.63	-13.00	-22.63	V
5557.64	-35.09	13.10	17.11	-39.10	-13.00	-26.10	V
7409.61	-31.86	11.50	22.20	-42.56	-13.00	-29.56	V
The Worst Test Results for Channel 9400/1880MHz							
Frequency(MHz)	S	Ant(dBi)	Loss	PMea	Limit	Margin	Polarity
	G.Lev (dBm)			(dBm)	(dBm)	(dBm)	
3759.84	-34.37	12.60	12.93	-34.70	-13.00	-21.70	H
5640.15	-34.36	13.10	17.11	-38.37	-13.00	-25.37	H
7520.30	-33.35	11.50	22.20	-44.05	-13.00	-31.05	H
3759.84	-34.65	12.60	12.93	-34.98	-13.00	-21.98	V
5640.15	-34.28	13.10	17.11	-38.29	-13.00	-25.29	V
7520.30	-32.47	11.50	22.20	-43.17	-13.00	-30.17	V
The Worst Test Results for Channel 9538/1907.6MHz							
Frequency(MHz)	S	Ant(dBi)	Loss	PMea	Limit	Margin	Polarity
	G.Lev (dBm)			(dBm)	(dBm)	(dBm)	
3815.68	-34.31	12.60	12.93	-34.64	-13.00	-21.64	H
5722.47	-35.08	13.10	17.11	-39.09	-13.00	-26.09	H
7630.37	-33.59	11.50	22.20	-44.29	-13.00	-31.29	H
3815.68	-35.33	12.60	12.93	-35.66	-13.00	-22.66	V
5722.47	-34.14	13.10	17.11	-38.15	-13.00	-25.15	V
7630.37	-32.73	11.50	22.20	-43.43	-13.00	-30.43	V



HSDPA Band 2: (30-20000)MHz							
The Worst Test Results for Channel 9262/1852.4MHz							
Frequency(MHz)	S	Ant(dBi)	Loss	PMea	Limit	Margin	Polarity
	G.Lev (dBm)			(dBm)	(dBm)	(dBm)	
3704.45	-34.66	12.60	12.93	-34.99	-13.00	-21.99	H
5557.61	-34.93	13.10	17.11	-38.94	-13.00	-25.94	H
7409.60	-33.46	11.50	22.20	-44.16	-13.00	-31.16	H
3704.45	-36.01	12.60	12.93	-36.34	-13.00	-23.34	V
5557.61	-33.87	13.10	17.11	-37.88	-13.00	-24.88	V
7409.60	-32.52	11.50	22.20	-43.22	-13.00	-30.22	V
The Worst Test Results for Channel 9400/1880MHz							
Frequency(MHz)	S	Ant(dBi)	Loss	PMea	Limit	Margin	Polarity
	G.Lev (dBm)			(dBm)	(dBm)	(dBm)	
3760.00	-34.44	12.60	12.93	-34.77	-13.00	-21.77	H
5640.22	-34.95	13.10	17.11	-38.96	-13.00	-25.96	H
7520.21	-33.34	11.50	22.20	-44.04	-13.00	-31.04	H
3760.00	-35.01	12.60	12.93	-35.34	-13.00	-22.34	V
5640.22	-34.96	13.10	17.11	-38.97	-13.00	-25.97	V
7520.21	-33.04	11.50	22.20	-43.74	-13.00	-30.74	V
The Worst Test Results for Channel 9538/1907.6MHz							
Frequency(MHz)	S	Ant(dBi)	Loss	PMea	Limit	Margin	Polarity
	G.Lev (dBm)			(dBm)	(dBm)	(dBm)	
3815.59	-34.44	12.60	12.93	-34.77	-13.00	-21.77	H
5722.51	-34.20	13.10	17.11	-38.21	-13.00	-25.21	H
7630.32	-32.66	11.50	22.20	-43.36	-13.00	-30.36	H
3815.59	-34.61	12.60	12.93	-34.94	-13.00	-21.94	V
5722.51	-34.45	13.10	17.11	-38.46	-13.00	-25.46	V
7630.32	-32.64	11.50	22.20	-43.34	-13.00	-30.34	V



WCDMA Band 5: (30-9000)MHz							
The most testresults channel 4132/826.4MHz							
Frequency(MHz)	S	Ant(dBi)	Loss	PMea	Limit	Margin	Polarity
	G.Lev (dBm)			(dBm)	(dBm)	(dBm)	
1652.87	-40.49	9.40	4.75	-35.84	-13.00	-22.84	H
2479.46	-39.23	10.60	8.39	-37.02	-13.00	-24.02	H
3305.54	-32.09	12.00	11.79	-31.88	-13.00	-18.88	H
1652.87	-43.17	9.40	4.75	-38.52	-13.00	-25.52	V
2479.46	-45.20	10.60	8.39	-42.99	-13.00	-29.99	V
3305.54	-42.54	12.00	11.79	-42.33	-13.00	-29.33	V
The Worst Test Results Channel 4182/836.4MHz							
Frequency(MHz)	S	Ant(dBi)	Loss	PMea	Limit	Margin	Polarity
	G.Lev (dBm)			(dBm)	(dBm)	(dBm)	
1672.76	-41.23	9.40	4.75	-36.58	-13.00	-23.58	H
2509.33	-39.54	10.60	8.39	-37.33	-13.00	-24.33	H
3345.44	-32.21	12.00	11.79	-32.00	-13.00	-19.00	H
1672.76	-43.49	9.40	4.75	-38.84	-13.00	-25.84	V
2509.33	-44.19	10.60	8.39	-41.98	-13.00	-28.98	V
3345.44	-43.22	12.00	11.79	-43.01	-13.00	-30.01	V
The Worst Test Results Channel 4233/846.6MHz							
Frequency(MHz)	S	Ant(dBi)	Loss	PMea	Limit	Margin	Polarity
	G.Lev (dBm)			(dBm)	(dBm)	(dBm)	
1693.20	-40.44	9.40	4.75	-35.79	-13.00	-22.79	H
2539.56	-40.46	10.60	8.39	-38.25	-13.00	-25.25	H
3386.12	-32.06	12.00	11.79	-31.85	-13.00	-18.85	H
1693.20	-43.51	9.40	4.75	-38.86	-13.00	-25.86	V
2539.56	-45.00	10.60	8.39	-42.79	-13.00	-29.79	V
3386.12	-43.43	12.00	11.79	-43.22	-13.00	-30.22	V



HSUPA Band 5: (30-9000)MHz							
The most testresults channel 4132/826.4MHz							
Frequency(MHz)	S		Loss	PMea	Limit	Margin	Polarity
	G.Lev (dBm)	Ant(dBi)		(dBm)	(dBm)	(dBm)	
1652.51	-41.31	9.40	4.75	-36.66	-13.00	-23.66	H
2479.07	-40.50	10.60	8.39	-38.29	-13.00	-25.29	H
3305.94	-32.14	12.00	11.79	-31.93	-13.00	-18.93	H
1652.51	-43.44	9.40	4.75	-38.79	-13.00	-25.79	V
2479.07	-45.21	10.60	8.39	-43.00	-13.00	-30.00	V
3305.94	-43.03	12.00	11.79	-42.82	-13.00	-29.82	V
The Worst Test Results Channel 4182/836.4MHz							
Frequency(MHz)	S		Loss	PMea	Limit	Margin	Polarity
	G.Lev (dBm)	Ant(dBi)		(dBm)	(dBm)	(dBm)	
1672.61	-40.29	9.40	4.75	-35.64	-13.00	-22.64	H
2509.42	-39.98	10.60	8.39	-37.77	-13.00	-24.77	H
3345.82	-30.85	12.00	11.79	-30.64	-13.00	-17.64	H
1672.61	-44.47	9.40	4.75	-39.82	-13.00	-26.82	V
2509.42	-45.39	10.60	8.39	-43.18	-13.00	-30.18	V
3345.82	-42.93	12.00	11.79	-42.72	-13.00	-29.72	V
The Worst Test Results Channel 4233/846.6MHz							
Frequency(MHz)	S		Loss	PMea	Limit	Margin	Polarity
	G.Lev (dBm)	Ant(dBi)		(dBm)	(dBm)	(dBm)	
1693.50	-40.31	9.40	4.75	-35.66	-13.00	-22.66	H
2539.97	-39.60	10.60	8.39	-37.39	-13.00	-24.39	H
3386.14	-30.98	12.00	11.79	-30.77	-13.00	-17.77	H
1693.50	-43.50	9.40	4.75	-38.85	-13.00	-25.85	V
2539.97	-44.83	10.60	8.39	-42.62	-13.00	-29.62	V
3386.14	-43.13	12.00	11.79	-42.92	-13.00	-29.92	V



HSDPA Band 5: (30-9000)MHz							
The most testresults channel 4132/826.4MHz							
Frequency(MHz)	S	Ant(dBi)	Loss	PMea	Limit	Margin	Polarity
	G.Lev (dBm)			(dBm)	(dBm)	(dBm)	
1652.86	-41.23	9.40	4.75	-36.58	-13.00	-23.58	H
2479.10	-40.40	10.60	8.39	-38.19	-13.00	-25.19	H
3305.58	-31.98	12.00	11.79	-31.77	-13.00	-18.77	H
1652.86	-44.48	9.40	4.75	-39.83	-13.00	-26.83	V
2479.10	-44.58	10.60	8.39	-42.37	-13.00	-29.37	V
3305.58	-43.08	12.00	11.79	-42.87	-13.00	-29.87	V
The Worst Test Results Channel 4182/836.4MHz							
Frequency(MHz)	S	Ant(dBi)	Loss	PMea	Limit	Margin	Polarity
	G.Lev (dBm)			(dBm)	(dBm)	(dBm)	
1672.88	-40.72	9.40	4.75	-36.07	-13.00	-23.07	H
2509.25	-39.53	10.60	8.39	-37.32	-13.00	-24.32	H
3345.41	-31.62	12.00	11.79	-31.41	-13.00	-18.41	H
1672.88	-44.59	9.40	4.75	-39.94	-13.00	-26.94	V
2509.25	-45.42	10.60	8.39	-43.21	-13.00	-30.21	V
3345.41	-42.85	12.00	11.79	-42.64	-13.00	-29.64	V
The Worst Test Results Channel 4233/846.6MHz							
Frequency(MHz)	S	Ant(dBi)	Loss	PMea	Limit	Margin	Polarity
	G.Lev (dBm)			(dBm)	(dBm)	(dBm)	
1693.32	-40.52	9.40	4.75	-35.87	-13.00	-22.87	H
2539.58	-40.44	10.60	8.39	-38.23	-13.00	-25.23	H
3386.15	-31.76	12.00	11.79	-31.55	-13.00	-18.55	H
1693.32	-43.36	9.40	4.75	-38.71	-13.00	-25.71	V
2539.58	-43.98	10.60	8.39	-41.77	-13.00	-28.77	V
3386.15	-43.19	12.00	11.79	-42.98	-13.00	-29.98	V



LTE Band 2 / 1.4MHz / QPSK / RB Size 1 Offset 0/ The Worst Test Results for Lowest							
Frequency(MHz)	S G.Lev (dBm)	Ant(dBi)	Loss	PMea	Limit	Margin	Polarity
				(dBm)	(dBm)	(dBm)	
3701.13	-34.59	12.60	12.93	-34.92	-13.00	-21.92	H
5551.92	-34.55	13.10	17.11	-38.56	-13.00	-25.56	H
7402.76	-32.61	11.50	22.20	-43.31	-13.00	-30.31	H
3701.13	-35.64	12.60	12.93	-35.97	-13.00	-22.97	V
5551.92	-33.77	13.10	17.11	-37.78	-13.00	-24.78	V
7402.76	-31.73	11.50	22.20	-42.43	-13.00	-29.43	V
LTE Band 2 / 1.4MHz / QPSK / RB Size 1 Offset 0/ The Worst Test Results for Middle							
Frequency(MHz)	S G.Lev (dBm)	Ant(dBi)	Loss	PMea	Limit	Margin	Polarity
				(dBm)	(dBm)	(dBm)	
3760.25	-33.73	12.60	12.93	-34.06	-13.00	-21.06	H
5639.99	-35.16	13.10	17.11	-39.17	-13.00	-26.17	H
7519.95	-32.64	11.50	22.20	-43.34	-13.00	-30.34	H
3760.25	-35.86	12.60	12.93	-36.19	-13.00	-23.19	V
5639.99	-35.09	13.10	17.11	-39.10	-13.00	-26.10	V
7519.95	-32.36	11.50	22.20	-43.06	-13.00	-30.06	V
LTE Band 2 / 1.4MHz / QPSK / RB Size 1 Offset 0/ The Worst Test Results for Highest							
Frequency(MHz)	S G.Lev (dBm)	Ant(dBi)	Loss	PMea	Limit	Margin	Polarity
				(dBm)	(dBm)	(dBm)	
3818.43	-34.31	12.60	12.93	-34.64	-13.00	-21.64	H
5727.69	-34.15	13.10	17.11	-38.16	-13.00	-25.16	H
7637.22	-32.23	11.50	22.20	-42.93	-13.00	-29.93	H
3818.43	-35.32	12.60	12.93	-35.65	-13.00	-22.65	V
5727.69	-35.20	13.10	17.11	-39.21	-13.00	-26.21	V
7637.22	-31.93	11.50	22.20	-42.63	-13.00	-29.63	V



LTE Band 2 / 3MHz / QPSK / RB Size 1 Offset 0/ The Worst Test Results for Lowest							
Frequency(MHz)	S G.Lev (dBm)	Ant(dBi)	Loss	PMea	Limit	Margin	Polarity
				(dBm)	(dBm)	(dBm)	
3702.98	-34.35	12.60	12.93	-34.68	-13.00	-21.68	H
5554.43	-34.54	13.10	17.11	-38.55	-13.00	-25.55	H
7405.80	-32.66	11.50	22.20	-43.36	-13.00	-30.36	H
3702.98	-34.58	12.60	12.93	-34.91	-13.00	-21.91	V
5554.43	-35.23	13.10	17.11	-39.24	-13.00	-26.24	V
7405.80	-31.94	11.50	22.20	-42.64	-13.00	-29.64	V
LTE Band 2 / 3MHz / QPSK / RB Size 1 Offset 0/ The Worst Test Results for Middle							
Frequency(MHz)	S G.Lev (dBm)	Ant(dBi)	Loss	PMea	Limit	Margin	Polarity
				(dBm)	(dBm)	(dBm)	
3759.78	-34.23	12.60	12.93	-34.56	-13.00	-21.56	H
5640.09	-35.08	13.10	17.11	-39.09	-13.00	-26.09	H
7520.15	-32.83	11.50	22.20	-43.53	-13.00	-30.53	H
3759.78	-35.09	12.60	12.93	-35.42	-13.00	-22.42	V
5640.09	-34.85	13.10	17.11	-38.86	-13.00	-25.86	V
7520.15	-32.29	11.50	22.20	-42.99	-13.00	-29.99	V
LTE Band 2 / 3MHz / QPSK / RB Size 1 Offset 0/ The Worst Test Results for Highest							
Frequency(MHz)	S G.Lev (dBm)	Ant(dBi)	Loss	PMea	Limit	Margin	Polarity
				(dBm)	(dBm)	(dBm)	
3817.27	-34.68	12.60	12.93	-35.01	-13.00	-22.01	H
5725.46	-35.39	13.10	17.11	-39.40	-13.00	-26.40	H
7633.90	-33.04	11.50	22.20	-43.74	-13.00	-30.74	H
3817.27	-34.78	12.60	12.93	-35.11	-13.00	-22.11	V
5725.46	-35.20	13.10	17.11	-39.21	-13.00	-26.21	V
7633.90	-32.80	11.50	22.20	-43.50	-13.00	-30.50	V



LTE Band 2 / 5MHz / QPSK / RB Size 1 Offset 0/ The Worst Test Results for Lowest							
Frequency(MHz)	S G.Lev (dBm)	Ant(dBi)	Loss	PMea	Limit	Margin	Polarity
				(dBm)	(dBm)	(dBm)	
3705.01	-34.53	12.60	12.93	-34.86	-13.00	-21.86	H
5557.16	-35.02	13.10	17.11	-39.03	-13.00	-26.03	H
7409.84	-32.70	11.50	22.20	-43.40	-13.00	-30.40	H
3705.01	-35.95	12.60	12.93	-36.28	-13.00	-23.28	V
5557.16	-34.36	13.10	17.11	-38.37	-13.00	-25.37	V
7409.84	-32.71	11.50	22.20	-43.41	-13.00	-30.41	V
LTE Band 2 / 5MHz / QPSK / RB Size 1 Offset 0/ The Worst Test Results for Middle							
Frequency(MHz)	S G.Lev (dBm)	Ant(dBi)	Loss	PMea	Limit	Margin	Polarity
				(dBm)	(dBm)	(dBm)	
3759.81	-34.25	12.60	12.93	-34.58	-13.00	-21.58	H
5640.14	-34.16	13.10	17.11	-38.17	-13.00	-25.17	H
7520.22	-32.79	11.50	22.20	-43.49	-13.00	-30.49	H
3759.81	-34.64	12.60	12.93	-34.97	-13.00	-21.97	V
5640.14	-34.47	13.10	17.11	-38.48	-13.00	-25.48	V
7520.22	-31.90	11.50	22.20	-42.60	-13.00	-29.60	V
LTE Band 2 / 5MHz / QPSK / RB Size 1 Offset 0/ The Worst Test Results for Highest							
Frequency(MHz)	S G.Lev (dBm)	Ant(dBi)	Loss	PMea	Limit	Margin	Polarity
				(dBm)	(dBm)	(dBm)	
3815.38	-33.49	12.60	12.93	-33.82	-13.00	-20.82	H
5722.31	-34.16	13.10	17.11	-38.17	-13.00	-25.17	H
7630.05	-33.46	11.50	22.20	-44.16	-13.00	-31.16	H
3815.38	-34.94	12.60	12.93	-35.27	-13.00	-22.27	V
5722.31	-34.82	13.10	17.11	-38.83	-13.00	-25.83	V
7630.05	-32.29	11.50	22.20	-42.99	-13.00	-29.99	V



LTE Band 2 / 10MHz / QPSK / RB Size 1 Offset 0/ The Worst Test Results for Lowest							
Frequency(MHz)	S G.Lev (dBm)	Ant(dBi)	Loss	PMea	Limit	Margin	Polarity
				(dBm)	(dBm)	(dBm)	
3710.41	-34.76	12.60	12.93	-35.09	-13.00	-22.09	H
5565.32	-34.90	13.10	17.11	-38.91	-13.00	-25.91	H
7420.16	-32.49	11.50	22.20	-43.19	-13.00	-30.19	H
3710.41	-34.90	12.60	12.93	-35.23	-13.00	-22.23	V
5565.32	-34.64	13.10	17.11	-38.65	-13.00	-25.65	V
7420.16	-33.07	11.50	22.20	-43.77	-13.00	-30.77	V
LTE Band 2 / 10MHz / QPSK / RB Size 1 Offset 0/ The Worst Test Results for Middle							
Frequency(MHz)	S G.Lev (dBm)	Ant(dBi)	Loss	PMea	Limit	Margin	Polarity
				(dBm)	(dBm)	(dBm)	
3759.93	-34.62	12.60	12.93	-34.95	-13.00	-21.95	H
5640.16	-34.98	13.10	17.11	-38.99	-13.00	-25.99	H
7520.13	-32.77	11.50	22.20	-43.47	-13.00	-30.47	H
3759.93	-35.08	12.60	12.93	-35.41	-13.00	-22.41	V
5640.16	-34.63	13.10	17.11	-38.64	-13.00	-25.64	V
7520.13	-32.74	11.50	22.20	-43.44	-13.00	-30.44	V
LTE Band 2 / 10MHz / QPSK / RB Size 1 Offset 0/ The Worst Test Results for Highest							
Frequency(MHz)	S G.Lev (dBm)	Ant(dBi)	Loss	PMea	Limit	Margin	Polarity
				(dBm)	(dBm)	(dBm)	
3810.28	-34.86	12.60	12.93	-35.19	-13.00	-22.19	H
5714.74	-35.46	13.10	17.11	-39.47	-13.00	-26.47	H
7619.93	-33.45	11.50	22.20	-44.15	-13.00	-31.15	H
3810.28	-35.20	12.60	12.93	-35.53	-13.00	-22.53	V
5714.74	-34.60	13.10	17.11	-38.61	-13.00	-25.61	V
7619.93	-31.99	11.50	22.20	-42.69	-13.00	-29.69	V



LTE Band 2 / 15MHz / QPSK / RB Size 1 Offset 0/ The Worst Test Results for Lowest							
Frequency(MHz)	S G.Lev (dBm)	Ant(dBi)	Loss	PMea	Limit	Margin	Polarity
				(dBm)	(dBm)	(dBm)	
3715.26	-34.92	12.60	12.93	-35.25	-13.00	-22.25	H
5572.12	-34.26	13.10	17.11	-38.27	-13.00	-25.27	H
7430.42	-33.49	11.50	22.20	-44.19	-13.00	-31.19	H
3715.26	-34.86	12.60	12.93	-35.19	-13.00	-22.19	V
5572.12	-34.69	13.10	17.11	-38.70	-13.00	-25.70	V
7430.42	-32.42	11.50	22.20	-43.12	-13.00	-30.12	V
LTE Band 2 / 15MHz / QPSK / RB Size 1 Offset 0/ The Worst Test Results for Middle							
Frequency(MHz)	S G.Lev (dBm)	Ant(dBi)	Loss	PMea	Limit	Margin	Polarity
				(dBm)	(dBm)	(dBm)	
3760.22	-33.62	12.60	12.93	-33.95	-13.00	-20.95	H
5640.00	-34.85	13.10	17.11	-38.86	-13.00	-25.86	H
7519.86	-32.35	11.50	22.20	-43.05	-13.00	-30.05	H
3760.22	-35.17	12.60	12.93	-35.50	-13.00	-22.50	V
5640.00	-35.13	13.10	17.11	-39.14	-13.00	-26.14	V
7519.86	-32.46	11.50	22.20	-43.16	-13.00	-30.16	V
LTE Band 2 / 15MHz / QPSK / RB Size 1 Offset 0/ The Worst Test Results for Highest							
Frequency(MHz)	S G.Lev (dBm)	Ant(dBi)	Loss	PMea	Limit	Margin	Polarity
				(dBm)	(dBm)	(dBm)	
3805.16	-34.09	12.60	12.93	-34.42	-13.00	-21.42	H
5707.53	-34.29	13.10	17.11	-38.30	-13.00	-25.30	H
7609.84	-32.61	11.50	22.20	-43.31	-13.00	-30.31	H
3805.16	-35.16	12.60	12.93	-35.49	-13.00	-22.49	V
5707.53	-34.34	13.10	17.11	-38.35	-13.00	-25.35	V
7609.84	-32.91	11.50	22.20	-43.61	-13.00	-30.61	V



LTE Band 2 / 20MHz / QPSK / RB Size 1 Offset 0/ The Worst Test Results for Lowest							
Frequency(MHz)	S G.Lev (dBm)	Ant(dBi)	Loss	PMea	Limit	Margin	Polarity
				(dBm)	(dBm)	(dBm)	
3720.13	-33.64	12.60	12.93	-33.97	-13.00	-20.97	H
5580.49	-35.22	13.10	17.11	-39.23	-13.00	-26.23	H
7439.98	-32.97	11.50	22.20	-43.67	-13.00	-30.67	H
3720.13	-34.56	12.60	12.93	-34.89	-13.00	-21.89	V
5580.49	-34.35	13.10	17.11	-38.36	-13.00	-25.36	V
7439.98	-31.96	11.50	22.20	-42.66	-13.00	-29.66	V
LTE Band 2 / 20MHz / QPSK / RB Size 1 Offset 0/ The Worst Test Results for Middle							
Frequency(MHz)	S G.Lev (dBm)	Ant(dBi)	Loss	PMea	Limit	Margin	Polarity
				(dBm)	(dBm)	(dBm)	
3759.89	-33.52	12.60	12.93	-33.85	-13.00	-20.85	H
5639.81	-35.04	13.10	17.11	-39.05	-13.00	-26.05	H
7520.11	-32.25	11.50	22.20	-42.95	-13.00	-29.95	H
3759.89	-34.88	12.60	12.93	-35.21	-13.00	-22.21	V
5639.81	-34.33	13.10	17.11	-38.34	-13.00	-25.34	V
7520.11	-31.89	11.50	22.20	-42.59	-13.00	-29.59	V
LTE Band 2 / 20MHz / QPSK / RB Size 1 Offset 0/ The Worst Test Results for Highest							
Frequency(MHz)	S G.Lev (dBm)	Ant(dBi)	Loss	PMea	Limit	Margin	Polarity
				(dBm)	(dBm)	(dBm)	
3800.16	-34.87	12.60	12.93	-35.20	-13.00	-22.20	H
5699.74	-34.80	13.10	17.11	-38.81	-13.00	-25.81	H
7600.02	-33.37	11.50	22.20	-44.07	-13.00	-31.07	H
3800.16	-35.86	12.60	12.93	-36.19	-13.00	-23.19	V
5699.74	-34.51	13.10	17.11	-38.52	-13.00	-25.52	V
7600.02	-32.89	11.50	22.20	-43.59	-13.00	-30.59	V



LTE Band 4 / 1.4MHz / QPSK / RB Size 1 Offset 0/ The Worst Test Results for Lowest							
Frequency(MHz)	S G.Lev (dBm)	Ant(dBi)	Loss	PMea	Limit	Margin	Polarity
				(dBm)	(dBm)	(dBm)	
3420.88	-33.84	12.90	12.56	-33.50	-13.00	-20.50	H
5131.96	-35.40	13.10	16.32	-38.62	-13.00	-25.62	H
6842.69	-32.27	12.33	21.13	-41.07	-13.00	-28.07	H
3420.88	-34.75	12.90	12.56	-34.41	-13.00	-21.41	V
5131.96	-34.03	13.10	16.32	-37.25	-13.00	-24.25	V
6842.69	-33.15	12.33	21.13	-41.95	-13.00	-28.95	V
LTE Band 4 / 1.4MHz / QPSK / RB Size 1 Offset 0/ The Worst Test Results for Middle							
Frequency(MHz)	S G.Lev (dBm)	Ant(dBi)	Loss	PMea	Limit	Margin	Polarity
				(dBm)	(dBm)	(dBm)	
3464.58	-34.90	12.90	12.56	-34.56	-13.00	-21.56	H
5196.70	-35.05	13.10	16.32	-38.27	-13.00	-25.27	H
6929.97	-32.86	12.33	21.13	-41.66	-13.00	-28.66	H
3464.58	-35.05	12.90	12.56	-34.71	-13.00	-21.71	V
5196.70	-34.78	13.10	16.32	-38.00	-13.00	-25.00	V
6929.97	-33.02	12.33	21.13	-41.82	-13.00	-28.82	V
LTE Band 4 / 1.4MHz / QPSK / RB Size 1 Offset 0/ The Worst Test Results for Highest							
Frequency(MHz)	S G.Lev (dBm)	Ant(dBi)	Loss	PMea	Limit	Margin	Polarity
				(dBm)	(dBm)	(dBm)	
3508.47	-33.95	12.90	12.56	-33.61	-13.00	-20.61	H
5262.28	-35.30	13.10	16.32	-38.52	-13.00	-25.52	H
7015.67	-32.93	12.33	21.13	-41.73	-13.00	-28.73	H
3508.47	-35.17	12.90	12.56	-34.83	-13.00	-21.83	V
5262.28	-34.13	13.10	16.32	-37.35	-13.00	-24.35	V
7015.67	-32.61	12.33	21.13	-41.41	-13.00	-28.41	V



LTE Band 4 / 3MHz / QPSK / RB Size 1 Offset 0/ The Worst Test Results for Lowest							
Frequency(MHz)	S G.Lev (dBm)	Ant(dBi)	Loss	PMea	Limit	Margin	Polarity
				(dBm)	(dBm)	(dBm)	
3423.84	-34.67	12.90	12.56	-34.33	-13.00	-21.33	H
5136.04	-34.98	13.10	16.32	-38.20	-13.00	-25.20	H
6848.67	-32.49	12.33	21.13	-41.29	-13.00	-28.29	H
3423.84	-35.74	12.90	12.56	-35.40	-13.00	-22.40	V
5136.04	-34.13	13.10	16.32	-37.35	-13.00	-24.35	V
6848.67	-32.00	12.33	21.13	-40.80	-13.00	-27.80	V
LTE Band 4 / 3MHz / QPSK / RB Size 1 Offset 0/ The Worst Test Results for Middle							
Frequency(MHz)	S G.Lev (dBm)	Ant(dBi)	Loss	PMea	Limit	Margin	Polarity
				(dBm)	(dBm)	(dBm)	
3464.92	-34.64	12.90	12.56	-34.30	-13.00	-21.30	H
5196.94	-34.46	13.10	16.32	-37.68	-13.00	-24.68	H
6930.12	-33.07	12.33	21.13	-41.87	-13.00	-28.87	H
3464.92	-34.59	12.90	12.56	-34.25	-13.00	-21.25	V
5196.94	-34.12	13.10	16.32	-37.34	-13.00	-24.34	V
6930.12	-32.13	12.33	21.13	-40.93	-13.00	-27.93	V
LTE Band 4 / 3MHz / QPSK / RB Size 1 Offset 0/ The Worst Test Results for Highest							
Frequency(MHz)	S G.Lev (dBm)	Ant(dBi)	Loss	PMea	Limit	Margin	Polarity
				(dBm)	(dBm)	(dBm)	
3506.01	-34.86	12.90	12.56	-34.52	-13.00	-21.52	H
5262.00	-34.27	13.10	16.32	-37.49	-13.00	-24.49	H
7012.44	-33.57	12.33	21.13	-42.37	-13.00	-29.37	H
3506.01	-35.44	12.90	12.56	-35.10	-13.00	-22.10	V
5262.00	-34.62	13.10	16.32	-37.84	-13.00	-24.84	V
7012.44	-32.63	12.33	21.13	-41.43	-13.00	-28.43	V



LTE Band 4 / 5MHz / QPSK / RB Size 1 Offset 0/ The Worst Test Results for Lowest							
Frequency(MHz)	S G.Lev (dBm)	Ant(dBi)	Loss	PMea	Limit	Margin	Polarity
				(dBm)	(dBm)	(dBm)	
3424.86	-34.71	12.90	12.56	-34.37	-13.00	-21.37	H
5136.97	-34.91	13.10	16.32	-38.13	-13.00	-25.13	H
6849.94	-32.73	12.33	21.13	-41.53	-13.00	-28.53	H
3424.86	-35.61	12.90	12.56	-35.27	-13.00	-22.27	V
5136.97	-34.96	13.10	16.32	-38.18	-13.00	-25.18	V
6849.94	-32.13	12.33	21.13	-40.93	-13.00	-27.93	V
LTE Band 4 / 5MHz / QPSK / RB Size 1 Offset 0/ The Worst Test Results for Middle							
Frequency(MHz)	S G.Lev (dBm)	Ant(dBi)	Loss	PMea	Limit	Margin	Polarity
				(dBm)	(dBm)	(dBm)	
3464.59	-34.08	12.90	12.56	-33.74	-13.00	-20.74	H
5196.77	-35.41	13.10	16.32	-38.63	-13.00	-25.63	H
6929.99	-32.78	12.33	21.13	-41.58	-13.00	-28.58	H
3464.59	-35.72	12.90	12.56	-35.38	-13.00	-22.38	V
5196.77	-33.78	13.10	16.32	-37.00	-13.00	-24.00	V
6929.99	-32.36	12.33	21.13	-41.16	-13.00	-28.16	V
LTE Band 4 / 5MHz / QPSK / RB Size 1 Offset 0/ The Worst Test Results for Highest							
Frequency(MHz)	S G.Lev (dBm)	Ant(dBi)	Loss	PMea	Limit	Margin	Polarity
				(dBm)	(dBm)	(dBm)	
3504.91	-33.74	12.90	12.56	-33.40	-13.00	-20.40	H
5257.17	-34.16	13.10	16.32	-37.38	-13.00	-24.38	H
7009.82	-32.93	12.33	21.13	-41.73	-13.00	-28.73	H
3504.91	-35.99	12.90	12.56	-35.65	-13.00	-22.65	V
5257.17	-34.81	13.10	16.32	-38.03	-13.00	-25.03	V
7009.82	-31.90	12.33	21.13	-40.70	-13.00	-27.70	V



LTE Band 4 / 10MHz / QPSK / RB Size 1 Offset 0/ The Worst Test Results for Lowest							
Frequency(MHz)	S G.Lev (dBm)	Ant(dBi)	Loss	PMea	Limit	Margin	Polarity
				(dBm)	(dBm)	(dBm)	
3430.10	-34.66	12.90	12.56	-34.32	-13.00	-21.32	H
5145.28	-34.65	13.10	16.32	-37.87	-13.00	-24.87	H
6860.31	-32.27	12.33	21.13	-41.07	-13.00	-28.07	H
3430.10	-34.76	12.90	12.56	-34.42	-13.00	-21.42	V
5145.28	-34.42	13.10	16.32	-37.64	-13.00	-24.64	V
6860.31	-32.84	12.33	21.13	-41.64	-13.00	-28.64	V
LTE Band 4 / 10MHz / QPSK / RB Size 1 Offset 0/ The Worst Test Results for Middle							
Frequency(MHz)	S G.Lev (dBm)	Ant(dBi)	Loss	PMea	Limit	Margin	Polarity
				(dBm)	(dBm)	(dBm)	
3464.55	-33.57	12.90	12.56	-33.23	-13.00	-20.23	H
5196.77	-35.00	13.10	16.32	-38.22	-13.00	-25.22	H
6929.52	-32.30	12.33	21.13	-41.10	-13.00	-28.10	H
3464.55	-34.83	12.90	12.56	-34.49	-13.00	-21.49	V
5196.77	-34.13	13.10	16.32	-37.35	-13.00	-24.35	V
6929.52	-31.73	12.33	21.13	-40.53	-13.00	-27.53	V
LTE Band 4 / 10MHz / QPSK / RB Size 1 Offset 0/ The Worst Test Results for Highest							
Frequency(MHz)	S G.Lev (dBm)	Ant(dBi)	Loss	PMea	Limit	Margin	Polarity
				(dBm)	(dBm)	(dBm)	
3500.43	-33.91	12.90	12.56	-33.57	-13.00	-20.57	H
5250.26	-34.35	13.10	16.32	-37.57	-13.00	-24.57	H
6999.73	-33.35	12.33	21.13	-42.15	-13.00	-29.15	H
3500.43	-35.73	12.90	12.56	-35.39	-13.00	-22.39	V
5250.26	-34.10	13.10	16.32	-37.32	-13.00	-24.32	V
6999.73	-33.16	12.33	21.13	-41.96	-13.00	-28.96	V



LTE Band 4 / 15MHz / QPSK / RB Size 1 Offset 0/ The Worst Test Results for Lowest							
Frequency(MHz)	S G.Lev (dBm)	Ant(dBi)	Loss	PMea	Limit	Margin	Polarity
				(dBm)	(dBm)	(dBm)	
3434.97	-34.32	12.90	12.56	-33.98	-13.00	-20.98	H
5152.39	-34.65	13.10	16.32	-37.87	-13.00	-24.87	H
6870.52	-33.64	12.33	21.13	-42.44	-13.00	-29.44	H
3434.97	-35.80	12.90	12.56	-35.46	-13.00	-22.46	V
5152.39	-34.52	13.10	16.32	-37.74	-13.00	-24.74	V
6870.52	-32.45	12.33	21.13	-41.25	-13.00	-28.25	V
LTE Band 4 / 15MHz / QPSK / RB Size 1 Offset 0/ The Worst Test Results for Middle							
Frequency(MHz)	S G.Lev (dBm)	Ant(dBi)	Loss	PMea	Limit	Margin	Polarity
				(dBm)	(dBm)	(dBm)	
3464.95	-34.52	12.90	12.56	-34.18	-13.00	-21.18	H
5196.67	-34.71	13.10	16.32	-37.93	-13.00	-24.93	H
6930.11	-33.43	12.33	21.13	-42.23	-13.00	-29.23	H
3464.95	-34.66	12.90	12.56	-34.32	-13.00	-21.32	V
5196.67	-34.40	13.10	16.32	-37.62	-13.00	-24.62	V
6930.11	-32.49	12.33	21.13	-41.29	-13.00	-28.29	V
LTE Band 4 / 15MHz / QPSK / RB Size 1 Offset 0/ The Worst Test Results for Highest							
Frequency(MHz)	S G.Lev (dBm)	Ant(dBi)	Loss	PMea	Limit	Margin	Polarity
				(dBm)	(dBm)	(dBm)	
3495.31	-34.29	12.90	12.56	-33.95	-13.00	-20.95	H
5242.38	-35.42	13.10	16.32	-38.64	-13.00	-25.64	H
6990.00	-32.84	12.33	21.13	-41.64	-13.00	-28.64	H
3495.31	-35.19	12.90	12.56	-34.85	-13.00	-21.85	V
5242.38	-33.88	13.10	16.32	-37.10	-13.00	-24.10	V
6990.00	-32.37	12.33	21.13	-41.17	-13.00	-28.17	V



LTE Band 4 / 20MHz / QPSK / RB Size 1 Offset 0/ The Worst Test Results for Lowest							
Frequency(MHz)	S G.Lev (dBm)	Ant(dBi)	Loss	PMea	Limit	Margin	Polarity
				(dBm)	(dBm)	(dBm)	
3440.20	-34.78	12.90	12.56	-34.44	-13.00	-21.44	H
5160.29	-34.94	13.10	16.32	-38.16	-13.00	-25.16	H
6880.48	-33.21	12.33	21.13	-42.01	-13.00	-29.01	H
3440.20	-34.62	12.90	12.56	-34.28	-13.00	-21.28	V
5160.29	-34.01	13.10	16.32	-37.23	-13.00	-24.23	V
6880.48	-32.72	12.33	21.13	-41.52	-13.00	-28.52	V
LTE Band 4 / 20MHz / QPSK / RB Size 1 Offset 0/ The Worst Test Results for Middle							
Frequency(MHz)	S G.Lev (dBm)	Ant(dBi)	Loss	PMea	Limit	Margin	Polarity
				(dBm)	(dBm)	(dBm)	
3465.01	-33.72	12.90	12.56	-33.38	-13.00	-20.38	H
5196.43	-34.76	13.10	16.32	-37.98	-13.00	-24.98	H
6929.78	-32.30	12.33	21.13	-41.10	-13.00	-28.10	H
3465.01	-34.91	12.90	12.56	-34.57	-13.00	-21.57	V
5196.43	-35.08	13.10	16.32	-38.30	-13.00	-25.30	V
6929.78	-33.01	12.33	21.13	-41.81	-13.00	-28.81	V
LTE Band 4 / 20MHz / QPSK / RB Size 1 Offset 0/ The Worst Test Results for Highest							
Frequency(MHz)	S G.Lev (dBm)	Ant(dBi)	Loss	PMea	Limit	Margin	Polarity
				(dBm)	(dBm)	(dBm)	
3490.52	-34.44	12.90	12.56	-34.10	-13.00	-21.10	H
5235.26	-34.45	13.10	16.32	-37.67	-13.00	-24.67	H
6979.74	-32.18	12.33	21.13	-40.98	-13.00	-27.98	H
3490.52	-34.85	12.90	12.56	-34.51	-13.00	-21.51	V
5235.26	-34.36	13.10	16.32	-37.58	-13.00	-24.58	V
6979.74	-32.42	12.33	21.13	-41.22	-13.00	-28.22	V



LTE Band 5 / 1.4MHz / QPSK / RB Size 1 Offset 0/ The Worst Test Results for Lowest							
Frequency(MHz)	S G.Lev (dBm)	Ant(dBi)	Loss	PMea	Limit	Margin	Polarity
				(dBm)	(dBm)	(dBm)	
1648.66	-34.13	9.56	9.72	-34.29	-13.00	-21.29	H
2473.39	-34.79	10.50	10.86	-35.15	-13.00	-22.15	H
3298.64	-33.05	12.78	11.57	-31.84	-13.00	-18.84	H
1648.66	-35.14	9.56	9.72	-35.30	-13.00	-22.30	V
2473.39	-34.81	10.50	10.86	-35.17	-13.00	-22.17	V
3298.64	-31.80	12.78	11.57	-30.59	-13.00	-17.59	V
LTE Band 5 / 1.4MHz / QPSK / RB Size 1 Offset 0/ The Worst Test Results for Middle							
Frequency(MHz)	S G.Lev (dBm)	Ant(dBi)	Loss	PMea	Limit	Margin	Polarity
				(dBm)	(dBm)	(dBm)	
1672.50	-34.75	9.56	9.72	-34.91	-13.00	-21.91	H
2508.93	-35.44	10.50	10.86	-35.80	-13.00	-22.80	H
3345.57	-33.62	12.78	11.57	-32.41	-13.00	-19.41	H
1672.50	-35.79	9.56	9.72	-35.95	-13.00	-22.95	V
2508.93	-34.05	10.50	10.86	-34.41	-13.00	-21.41	V
3345.57	-31.86	12.78	11.57	-30.65	-13.00	-17.65	V
LTE Band 5 / 1.4MHz / QPSK / RB Size 1 Offset 0/ The Worst Test Results for Highest							
Frequency(MHz)	S G.Lev (dBm)	Ant(dBi)	Loss	PMea	Limit	Margin	Polarity
				(dBm)	(dBm)	(dBm)	
1696.02	-33.82	9.56	9.72	-33.98	-13.00	-20.98	H
2544.43	-35.08	10.50	10.86	-35.44	-13.00	-22.44	H
3393.14	-32.39	12.78	11.57	-31.18	-13.00	-18.18	H
1696.02	-34.56	9.56	9.72	-34.72	-13.00	-21.72	V
2544.43	-34.13	10.50	10.86	-34.49	-13.00	-21.49	V
3393.14	-31.85	12.78	11.57	-30.64	-13.00	-17.64	V



LTE Band 5 / 3MHz / QPSK / RB Size 1 Offset 0/ The Worst Test Results for Lowest							
Frequency(MHz)	S G.Lev (dBm)	Ant(dBi)	Loss	PMea	Limit	Margin	Polarity
				(dBm)	(dBm)	(dBm)	
1650.16	-33.94	9.56	9.72	-34.10	-13.00	-21.10	H
2475.95	-34.02	10.50	10.86	-34.38	-13.00	-21.38	H
3301.21	-32.85	12.78	11.57	-31.64	-13.00	-18.64	H
1650.16	-35.83	9.56	9.72	-35.99	-13.00	-22.99	V
2475.95	-34.23	10.50	10.86	-34.59	-13.00	-21.59	V
3301.21	-33.21	12.78	11.57	-32.00	-13.00	-19.00	V
LTE Band 5 / 3MHz / QPSK / RB Size 1 Offset 0/ The Worst Test Results for Middle							
Frequency(MHz)	S G.Lev (dBm)	Ant(dBi)	Loss	PMea	Limit	Margin	Polarity
				(dBm)	(dBm)	(dBm)	
1672.12	-34.81	9.56	9.72	-34.97	-13.00	-21.97	H
2508.84	-34.47	10.50	10.86	-34.83	-13.00	-21.83	H
3345.60	-33.22	12.78	11.57	-32.01	-13.00	-19.01	H
1672.12	-35.09	9.56	9.72	-35.25	-13.00	-22.25	V
2508.84	-34.86	10.50	10.86	-35.22	-13.00	-22.22	V
3345.60	-32.80	12.78	11.57	-31.59	-13.00	-18.59	V
LTE Band 5 / 3MHz / QPSK / RB Size 1 Offset 0/ The Worst Test Results for Highest							
Frequency(MHz)	S G.Lev (dBm)	Ant(dBi)	Loss	PMea	Limit	Margin	Polarity
				(dBm)	(dBm)	(dBm)	
1694.26	-34.46	9.56	9.72	-34.62	-13.00	-21.62	H
2541.94	-35.03	10.50	10.86	-35.39	-13.00	-22.39	H
3389.17	-33.54	12.78	11.57	-32.33	-13.00	-19.33	H
1694.26	-34.82	9.56	9.72	-34.98	-13.00	-21.98	V
2541.94	-33.83	10.50	10.86	-34.19	-13.00	-21.19	V
3389.17	-32.18	12.78	11.57	-30.97	-13.00	-17.97	V



LTE Band 5 / 5MHz / QPSK / RB Size 1 Offset 0/ The Worst Test Results for Lowest							
Frequency(MHz)	S G.Lev (dBm)	Ant(dBi)	Loss	PMea	Limit	Margin	Polarity
				(dBm)	(dBm)	(dBm)	
1652.56	-33.44	9.56	9.72	-33.60	-13.00	-20.60	H
2478.54	-34.10	10.50	10.86	-34.46	-13.00	-21.46	H
3305.38	-32.75	12.78	11.57	-31.54	-13.00	-18.54	H
1652.56	-35.54	9.56	9.72	-35.70	-13.00	-22.70	V
2478.54	-34.57	10.50	10.86	-34.93	-13.00	-21.93	V
3305.38	-32.30	12.78	11.57	-31.09	-13.00	-18.09	V
LTE Band 5 / 5MHz / QPSK / RB Size 1 Offset 0/ The Worst Test Results for Middle							
Frequency(MHz)	S G.Lev (dBm)	Ant(dBi)	Loss	PMea	Limit	Margin	Polarity
				(dBm)	(dBm)	(dBm)	
1672.16	-33.59	9.56	9.72	-33.75	-13.00	-20.75	H
2508.92	-34.44	10.50	10.86	-34.80	-13.00	-21.80	H
3345.45	-33.12	12.78	11.57	-31.91	-13.00	-18.91	H
1672.16	-34.72	9.56	9.72	-34.88	-13.00	-21.88	V
2508.92	-33.95	10.50	10.86	-34.31	-13.00	-21.31	V
3345.45	-33.14	12.78	11.57	-31.93	-13.00	-18.93	V
LTE Band 5 / 5MHz / QPSK / RB Size 1 Offset 0/ The Worst Test Results for Highest							
Frequency(MHz)	S G.Lev (dBm)	Ant(dBi)	Loss	PMea	Limit	Margin	Polarity
				(dBm)	(dBm)	(dBm)	
1692.17	-34.14	9.56	9.72	-34.30	-13.00	-21.30	H
2538.74	-34.12	10.50	10.86	-34.48	-13.00	-21.48	H
3385.54	-32.60	12.78	11.57	-31.39	-13.00	-18.39	H
1692.17	-35.95	9.56	9.72	-36.11	-13.00	-23.11	V
2538.74	-35.03	10.50	10.86	-35.39	-13.00	-22.39	V
3385.54	-32.81	12.78	11.57	-31.60	-13.00	-18.60	V



LTE Band 5 / 10MHz / QPSK / RB Size 1 Offset 0/ The Worst Test Results for Lowest							
Frequency(MHz)	S G.Lev (dBm)	Ant(dBi)	Loss	PMea	Limit	Margin	Polarity
				(dBm)	(dBm)	(dBm)	
1657.69	-34.48	9.56	9.72	-34.64	-13.00	-21.64	H
2486.42	-34.44	10.50	10.86	-34.80	-13.00	-21.80	H
3315.34	-33.19	12.78	11.57	-31.98	-13.00	-18.98	H
1657.69	-35.27	9.56	9.72	-35.43	-13.00	-22.43	V
2486.42	-34.72	10.50	10.86	-35.08	-13.00	-22.08	V
3315.34	-32.10	12.78	11.57	-30.89	-13.00	-17.89	V
LTE Band 5 / 10MHz / QPSK / RB Size 1 Offset 0/ The Worst Test Results for Middle							
Frequency(MHz)	S G.Lev (dBm)	Ant(dBi)	Loss	PMea	Limit	Margin	Polarity
				(dBm)	(dBm)	(dBm)	
1672.32	-34.21	9.56	9.72	-34.37	-13.00	-21.37	H
2508.98	-34.62	10.50	10.86	-34.98	-13.00	-21.98	H
3345.34	-33.29	12.78	11.57	-32.08	-13.00	-19.08	H
1672.32	-34.84	9.56	9.72	-35.00	-13.00	-22.00	V
2508.98	-34.26	10.50	10.86	-34.62	-13.00	-21.62	V
3345.34	-31.82	12.78	11.57	-30.61	-13.00	-17.61	V
LTE Band 5 / 10MHz / QPSK / RB Size 1 Offset 0/ The Worst Test Results for Highest							
Frequency(MHz)	S G.Lev (dBm)	Ant(dBi)	Loss	PMea	Limit	Margin	Polarity
				(dBm)	(dBm)	(dBm)	
1687.64	-33.51	9.56	9.72	-33.67	-13.00	-20.67	H
2531.37	-34.36	10.50	10.86	-34.72	-13.00	-21.72	H
3375.46	-33.39	12.78	11.57	-32.18	-13.00	-19.18	H
1687.64	-34.87	9.56	9.72	-35.03	-13.00	-22.03	V
2531.37	-34.00	10.50	10.86	-34.36	-13.00	-21.36	V
3375.46	-32.41	12.78	11.57	-31.20	-13.00	-18.20	V



LTE Band 7 / 5MHz / QPSK / RB Size 1 Offset 0/ The Worst Test Results for Lowest							
Frequency(MHz)	S G.Lev (dBm)	Ant(dBi)	Loss	PMea	Limit	Margin	Polarity
				(dBm)	(dBm)	(dBm)	
5005.27	-34.37	12.66	15.86	-37.57	-25.00	-12.57	H
7507.55	-34.44	11.46	19.28	-42.26	-25.00	-17.26	H
10010.39	-33.30	12.79	23.19	-43.70	-25.00	-18.70	H
5005.27	-35.60	12.66	15.86	-38.80	-25.00	-13.80	V
7507.55	-33.98	11.46	19.28	-41.80	-25.00	-16.80	V
10010.39	-31.97	12.79	23.19	-42.37	-25.00	-17.37	V
LTE Band 7 / 5MHz / QPSK / RB Size 1 Offset 0/ The Worst Test Results for Middle							
Frequency(MHz)	S G.Lev (dBm)	Ant(dBi)	Loss	PMea	Limit	Margin	Polarity
				(dBm)	(dBm)	(dBm)	
5069.61	-34.04	12.72	15.86	-37.18	-25.00	-12.18	H
7605.05	-35.41	11.46	19.28	-43.23	-25.00	-18.23	H
10139.87	-33.45	12.09	23.19	-44.55	-25.00	-19.55	H
5069.61	-35.63	12.72	15.86	-38.77	-25.00	-13.77	V
7605.05	-35.05	11.46	19.28	-42.87	-25.00	-17.87	V
10139.87	-32.32	12.09	23.19	-43.42	-25.00	-18.42	V
LTE Band 7 / 5MHz / QPSK / RB Size 1 Offset 0/ The Worst Test Results for Highest							
Frequency(MHz)	S G.Lev (dBm)	Ant(dBi)	Loss	PMea	Limit	Margin	Polarity
				(dBm)	(dBm)	(dBm)	
5133.90	-33.78	12.76	15.86	-36.88	-25.00	-11.88	H
7701.49	-34.26	11.45	19.28	-42.09	-25.00	-17.09	H
10268.41	-32.41	12.28	23.19	-43.32	-25.00	-18.32	H
5133.90	-35.69	12.76	15.86	-38.79	-25.00	-13.79	V
7701.49	-34.54	11.45	19.28	-42.37	-25.00	-17.37	V
10268.41	-32.52	12.28	23.19	-43.43	-25.00	-18.43	V



LTE Band 7 / 10MHz / QPSK / RB Size 1 Offset 0/ The Worst Test Results for Lowest							
Frequency(MHz)	S G.Lev (dBm)	Ant(dBi)	Loss	PMea	Limit	Margin	Polarity
				(dBm)	(dBm)	(dBm)	
5010.31	-34.60	12.66	15.86	-37.80	-25.00	-12.80	H
7515.66	-34.33	11.46	19.28	-42.15	-25.00	-17.15	H
10020.55	-32.64	12.79	23.19	-43.04	-25.00	-18.04	H
5010.31	-35.77	12.66	15.86	-38.97	-25.00	-13.97	V
7515.66	-34.01	11.46	19.28	-41.83	-25.00	-16.83	V
10020.55	-33.05	12.79	23.19	-43.45	-25.00	-18.45	V
LTE Band 7 / 10MHz / QPSK / RB Size 1 Offset 0/ The Worst Test Results for Middle							
Frequency(MHz)	S G.Lev (dBm)	Ant(dBi)	Loss	PMea	Limit	Margin	Polarity
				(dBm)	(dBm)	(dBm)	
5069.78	-34.65	12.72	15.86	-37.79	-25.00	-12.79	H
7604.88	-35.37	11.46	19.28	-43.19	-25.00	-18.19	H
10139.65	-32.63	12.09	23.19	-43.73	-25.00	-18.73	H
5069.78	-35.08	12.72	15.86	-38.22	-25.00	-13.22	V
7604.88	-34.81	11.46	19.28	-42.63	-25.00	-17.63	V
10139.65	-32.93	12.09	23.19	-44.03	-25.00	-19.03	V
LTE Band 7 / 10MHz / QPSK / RB Size 1 Offset 0/ The Worst Test Results for Highest							
Frequency(MHz)	S G.Lev (dBm)	Ant(dBi)	Loss	PMea	Limit	Margin	Polarity
				(dBm)	(dBm)	(dBm)	
5129.12	-33.58	12.76	15.86	-36.68	-25.00	-11.68	H
7693.90	-34.88	11.45	19.28	-42.71	-25.00	-17.71	H
10258.73	-33.32	12.28	23.19	-44.23	-25.00	-19.23	H
5129.12	-35.07	12.76	15.86	-38.17	-25.00	-13.17	V
7693.90	-34.82	11.45	19.28	-42.65	-25.00	-17.65	V
10258.73	-32.78	12.28	23.19	-43.69	-25.00	-18.69	V



LTE Band 7 / 15MHz / QPSK / RB Size 1 Offset 0/ The Worst Test Results for Lowest							
Frequency(MHz)	S G.Lev (dBm)	Ant(dBi)	Loss	PMea	Limit	Margin	Polarity
				(dBm)	(dBm)	(dBm)	
5015.60	-33.90	12.66	15.86	-37.10	-25.00	-12.10	H
7523.88	-34.97	11.46	19.28	-42.79	-25.00	-17.79	H
10031.58	-32.80	12.79	23.19	-43.20	-25.00	-18.20	H
5015.60	-34.81	12.66	15.86	-38.01	-25.00	-13.01	V
7523.88	-34.45	11.46	19.28	-42.27	-25.00	-17.27	V
10031.58	-32.35	12.79	23.19	-42.75	-25.00	-17.75	V
LTE Band 7 / 15MHz / QPSK / RB Size 1 Offset 0/ The Worst Test Results for Middle							
Frequency(MHz)	S G.Lev (dBm)	Ant(dBi)	Loss	PMea	Limit	Margin	Polarity
				(dBm)	(dBm)	(dBm)	
5069.82	-34.43	12.72	15.86	-37.57	-25.00	-12.57	H
7604.76	-35.00	11.46	19.28	-42.82	-25.00	-17.82	H
10139.71	-32.21	12.09	23.19	-43.31	-25.00	-18.31	H
5069.82	-35.95	12.72	15.86	-39.09	-25.00	-14.09	V
7604.76	-34.22	11.46	19.28	-42.04	-25.00	-17.04	V
10139.71	-32.72	12.09	23.19	-43.82	-25.00	-18.82	V
LTE Band 7 / 15MHz / QPSK / RB Size 1 Offset 0/ The Worst Test Results for Highest							
Frequency(MHz)	S G.Lev (dBm)	Ant(dBi)	Loss	PMea	Limit	Margin	Polarity
				(dBm)	(dBm)	(dBm)	
5123.27	-33.60	12.76	15.86	-36.70	-25.00	-11.70	H
7524.01	-34.18	11.45	19.28	-42.01	-25.00	-17.01	H
10032.18	-33.03	12.28	23.19	-43.94	-25.00	-18.94	H
5123.27	-35.32	12.76	15.86	-38.42	-25.00	-13.42	V
7524.01	-34.55	11.45	19.28	-42.38	-25.00	-17.38	V
10032.18	-32.79	12.28	23.19	-43.70	-25.00	-18.70	V



LTE Band 7 / 20MHz / QPSK / RB Size 1 Offset 0/ The Worst Test Results for Lowest							
Frequency(MHz)	S G.Lev (dBm)	Ant(dBi)	Loss	PMea	Limit	Margin	Polarity
				(dBm)	(dBm)	(dBm)	
5021.10	-34.36	12.66	15.86	-37.56	-25.00	-12.56	H
7531.21	-34.56	11.46	19.28	-42.38	-25.00	-17.38	H
10258.98	-32.48	12.79	23.19	-42.88	-25.00	-17.88	H
5021.10	-35.32	12.66	15.86	-38.52	-25.00	-13.52	V
7531.21	-33.75	11.46	19.28	-41.57	-25.00	-16.57	V
10258.98	-32.04	12.79	23.19	-42.44	-25.00	-17.44	V
LTE Band 7 / 20MHz / QPSK / RB Size 1 Offset 0/ The Worst Test Results for Middle							
Frequency(MHz)	S G.Lev (dBm)	Ant(dBi)	Loss	PMea	Limit	Margin	Polarity
				(dBm)	(dBm)	(dBm)	
5069.98	-34.12	12.72	15.86	-37.26	-25.00	-12.26	H
7605.16	-35.45	11.46	19.28	-43.27	-25.00	-18.27	H
10139.75	-33.10	12.09	23.19	-44.20	-25.00	-19.20	H
5069.98	-34.72	12.72	15.86	-37.86	-25.00	-12.86	V
7605.16	-34.73	11.46	19.28	-42.55	-25.00	-17.55	V
10139.75	-32.59	12.09	23.19	-43.69	-25.00	-18.69	V
LTE Band 7 / 20MHz / QPSK / RB Size 1 Offset 0/ The Worst Test Results for Highest							
Frequency(MHz)	S G.Lev (dBm)	Ant(dBi)	Loss	PMea	Limit	Margin	Polarity
				(dBm)	(dBm)	(dBm)	
5118.69	-34.65	12.76	15.86	-37.75	-25.00	-12.75	H
7678.21	-34.94	11.45	19.28	-42.77	-25.00	-17.77	H
10237.64	-32.93	12.28	23.19	-43.84	-25.00	-18.84	H
5118.69	-34.69	12.76	15.86	-37.79	-25.00	-12.79	V
7678.21	-34.28	11.45	19.28	-42.11	-25.00	-17.11	V
10237.64	-32.15	12.28	23.19	-43.06	-25.00	-18.06	V



LTE Band 12 / 1.4MHz / QPSK / RB Size 1 Offset 0/ The Worst Test Results for Lowest							
Frequency(MHz)	S G.Lev (dBm)	Ant(dBi)	Loss	PMea	Limit	Margin	Polarity
				(dBm)	(dBm)	(dBm)	
1399.05	-34.00	8.17	9.34	-35.17	-13.00	-22.17	H
2098.98	-35.31	9.53	10.42	-36.20	-13.00	-23.20	H
2798.78	-32.73	11.27	11.12	-32.58	-13.00	-19.58	H
1399.05	-35.87	8.17	9.34	-37.04	-13.00	-24.04	V
2098.98	-33.93	9.53	10.42	-34.82	-13.00	-21.82	V
2798.78	-32.59	11.27	11.12	-32.44	-13.00	-19.44	V
LTE Band 12 / 1.4MHz / QPSK / RB Size 1 Offset 0/ The Worst Test Results for Middle							
Frequency(MHz)	S G.Lev (dBm)	Ant(dBi)	Loss	PMea	Limit	Margin	Polarity
				(dBm)	(dBm)	(dBm)	
1414.90	-34.12	8.17	9.34	-35.29	-13.00	-22.29	H
2122.28	-34.11	9.53	10.42	-35.00	-13.00	-22.00	H
2829.64	-33.25	11.27	11.12	-33.10	-13.00	-20.10	H
1414.90	-35.81	8.17	9.34	-36.98	-13.00	-23.98	V
2122.28	-34.46	9.53	10.42	-35.35	-13.00	-22.35	V
2829.64	-32.85	11.27	11.12	-32.70	-13.00	-19.70	V
LTE Band 12 / 1.4MHz / QPSK / RB Size 1 Offset 0/ The Worst Test Results for Highest							
Frequency(MHz)	S G.Lev (dBm)	Ant(dBi)	Loss	PMea	Limit	Margin	Polarity
				(dBm)	(dBm)	(dBm)	
1430.47	-33.58	8.17	9.34	-34.75	-13.00	-21.75	H
2145.55	-34.06	9.53	10.42	-34.95	-13.00	-21.95	H
2860.93	-32.18	11.27	11.12	-32.03	-13.00	-19.03	H
1430.47	-35.29	8.17	9.34	-36.46	-13.00	-23.46	V
2145.55	-34.05	9.53	10.42	-34.94	-13.00	-21.94	V
2860.93	-32.35	11.27	11.12	-32.20	-13.00	-19.20	V



LTE Band 12 / 3MHz / QPSK / RB Size 1 Offset 0/ The Worst Test Results for Lowest							
Frequency(MHz)	S G.Lev (dBm)	Ant(dBi)	Loss	PMea	Limit	Margin	Polarity
				(dBm)	(dBm)	(dBm)	
1400.76	-33.56	8.17	9.34	-34.73	-13.00	-21.73	H
2101.28	-34.39	9.53	10.42	-35.28	-13.00	-22.28	H
2801.83	-32.74	11.27	11.12	-32.59	-13.00	-19.59	H
1400.76	-34.61	8.17	9.34	-35.78	-13.00	-22.78	V
2101.28	-35.09	9.53	10.42	-35.98	-13.00	-22.98	V
2801.83	-32.64	11.27	11.12	-32.49	-13.00	-19.49	V
LTE Band 12 / 3MHz / QPSK / RB Size 1 Offset 0/ The Worst Test Results for Middle							
Frequency(MHz)	S G.Lev (dBm)	Ant(dBi)	Loss	PMea	Limit	Margin	Polarity
				(dBm)	(dBm)	(dBm)	
1414.64	-34.90	8.17	9.34	-36.07	-13.00	-23.07	H
2122.30	-35.38	9.53	10.42	-36.27	-13.00	-23.27	H
2829.77	-32.68	11.27	11.12	-32.53	-13.00	-19.53	H
1414.64	-35.21	8.17	9.34	-36.38	-13.00	-23.38	V
2122.30	-34.52	9.53	10.42	-35.41	-13.00	-22.41	V
2829.77	-32.65	11.27	11.12	-32.50	-13.00	-19.50	V
LTE Band 12 / 3MHz / QPSK / RB Size 1 Offset 0/ The Worst Test Results for Highest							
Frequency(MHz)	S G.Lev (dBm)	Ant(dBi)	Loss	PMea	Limit	Margin	Polarity
				(dBm)	(dBm)	(dBm)	
1428.97	-34.93	8.17	9.34	-36.10	-13.00	-23.10	H
2143.11	-34.59	9.53	10.42	-35.48	-13.00	-22.48	H
2857.85	-33.40	11.27	11.12	-33.25	-13.00	-20.25	H
1428.97	-35.60	8.17	9.34	-36.77	-13.00	-23.77	V
2143.11	-34.84	9.53	10.42	-35.73	-13.00	-22.73	V
2857.85	-33.06	11.27	11.12	-32.91	-13.00	-19.91	V



LTE Band 12 / 5MHz / QPSK / RB Size 1 Offset 0/ The Worst Test Results for Lowest							
Frequency(MHz)	S G.Lev (dBm)	Ant(dBi)	Loss	PMea	Limit	Margin	Polarity
				(dBm)	(dBm)	(dBm)	
1402.61	-33.93	8.17	9.34	-35.10	-13.00	-22.10	H
2104.36	-34.49	9.53	10.42	-35.38	-13.00	-22.38	H
2805.87	-32.71	11.27	11.12	-32.56	-13.00	-19.56	H
1402.61	-35.86	8.17	9.34	-37.03	-13.00	-24.03	V
2104.36	-35.20	9.53	10.42	-36.09	-13.00	-23.09	V
2805.87	-32.71	11.27	11.12	-32.56	-13.00	-19.56	V
LTE Band 12 / 5MHz / QPSK / RB Size 1 Offset 0/ The Worst Test Results for Middle							
Frequency(MHz)	S G.Lev (dBm)	Ant(dBi)	Loss	PMea	Limit	Margin	Polarity
				(dBm)	(dBm)	(dBm)	
1414.91	-34.77	8.17	9.34	-35.94	-13.00	-22.94	H
2122.05	-35.21	9.53	10.42	-36.10	-13.00	-23.10	H
2829.59	-32.85	11.27	11.12	-32.70	-13.00	-19.70	H
1414.91	-35.72	8.17	9.34	-36.89	-13.00	-23.89	V
2122.05	-34.04	9.53	10.42	-34.93	-13.00	-21.93	V
2829.59	-33.18	11.27	11.12	-33.03	-13.00	-20.03	V
LTE Band 12 / 5MHz / QPSK / RB Size 1 Offset 0/ The Worst Test Results for Highest							
Frequency(MHz)	S G.Lev (dBm)	Ant(dBi)	Loss	PMea	Limit	Margin	Polarity
				(dBm)	(dBm)	(dBm)	
1426.75	-34.53	8.17	9.34	-35.70	-13.00	-22.70	H
2140.48	-34.45	9.53	10.42	-35.34	-13.00	-22.34	H
2853.66	-32.62	11.27	11.12	-32.47	-13.00	-19.47	H
1426.75	-35.07	8.17	9.34	-36.24	-13.00	-23.24	V
2140.48	-34.75	9.53	10.42	-35.64	-13.00	-22.64	V
2853.66	-32.90	11.27	11.12	-32.75	-13.00	-19.75	V



LTE Band 12 / 10MHz / QPSK / RB Size 1 Offset 0/ The Worst Test Results for Lowest							
Frequency(MHz)	S G.Lev (dBm)	Ant(dBi)	Loss	PMea	Limit	Margin	Polarity
				(dBm)	(dBm)	(dBm)	
1407.98	-33.74	8.17	9.34	-34.91	-13.00	-21.91	H
2111.80	-34.61	9.53	10.42	-35.50	-13.00	-22.50	H
2815.91	-32.40	11.27	11.12	-32.25	-13.00	-19.25	H
1407.98	-34.79	8.17	9.34	-35.96	-13.00	-22.96	V
2111.80	-33.86	9.53	10.42	-34.75	-13.00	-21.75	V
2815.91	-32.30	11.27	11.12	-32.15	-13.00	-19.15	V
LTE Band 12 / 10MHz / QPSK / RB Size 1 Offset 0/ The Worst Test Results for Middle							
Frequency(MHz)	S G.Lev (dBm)	Ant(dBi)	Loss	PMea	Limit	Margin	Polarity
				(dBm)	(dBm)	(dBm)	
1414.78	-34.25	8.17	9.34	-35.42	-13.00	-22.42	H
2122.09	-34.67	9.53	10.42	-35.56	-13.00	-22.56	H
2829.88	-32.42	11.27	11.12	-32.27	-13.00	-19.27	H
1414.78	-35.24	8.17	9.34	-36.41	-13.00	-23.41	V
2122.09	-34.78	9.53	10.42	-35.67	-13.00	-22.67	V
2829.88	-32.22	11.27	11.12	-32.07	-13.00	-19.07	V
LTE Band 12 / 10MHz / QPSK / RB Size 1 Offset 0/ The Worst Test Results for Highest							
Frequency(MHz)	S G.Lev (dBm)	Ant(dBi)	Loss	PMea	Limit	Margin	Polarity
				(dBm)	(dBm)	(dBm)	
1421.54	-33.78	8.17	9.34	-34.95	-13.00	-21.95	H
2132.72	-34.00	9.53	10.42	-34.89	-13.00	-21.89	H
2843.55	-32.23	11.27	11.12	-32.08	-13.00	-19.08	H
1421.54	-35.52	8.17	9.34	-36.69	-13.00	-23.69	V
2132.72	-34.19	9.53	10.42	-35.08	-13.00	-22.08	V
2843.55	-32.52	11.27	11.12	-32.37	-13.00	-19.37	V



LTE Band 17 / 5MHz / QPSK / RB Size 1 Offset 0/ The Worst Test Results for Lowest							
Frequency(MHz)	S G.Lev (dBm)	Ant(dBi)	Loss	PMea	Limit	Margin	Polarity
				(dBm)	(dBm)	(dBm)	
1413.32	-34.71	8.17	9.34	-35.88	-13.00	-22.88	H
2120.65	-34.31	9.53	10.42	-35.20	-13.00	-22.20	H
2826.62	-32.48	11.27	11.12	-32.33	-13.00	-19.33	H
1413.32	-34.93	8.17	9.34	-36.10	-13.00	-23.10	V
2120.65	-35.08	9.53	10.42	-35.97	-13.00	-22.97	V
2826.62	-32.44	11.27	11.12	-32.29	-13.00	-19.29	V
LTE Band 17 / 5MHz / QPSK / RB Size 1 Offset 0/ The Worst Test Results for Middle							
Frequency(MHz)	S G.Lev (dBm)	Ant(dBi)	Loss	PMea	Limit	Margin	Polarity
				(dBm)	(dBm)	(dBm)	
1419.80	-34.64	8.17	9.34	-35.81	-13.00	-22.81	H
2130.11	-35.19	9.53	10.42	-36.08	-13.00	-23.08	H
2840.08	-32.92	11.27	11.12	-32.77	-13.00	-19.77	H
1419.80	-35.46	8.17	9.34	-36.63	-13.00	-23.63	V
2130.11	-34.57	9.53	10.42	-35.46	-13.00	-22.46	V
2840.08	-32.44	11.27	11.12	-32.29	-13.00	-19.29	V
LTE Band 17 / 5MHz / QPSK / RB Size 1 Offset 0/ The Worst Test Results for Highest							
Frequency(MHz)	S G.Lev (dBm)	Ant(dBi)	Loss	PMea	Limit	Margin	Polarity
				(dBm)	(dBm)	(dBm)	
1426.19	-34.50	8.17	9.34	-35.67	-13.00	-22.67	H
2139.28	-34.70	9.53	10.42	-35.59	-13.00	-22.59	H
2852.79	-32.83	11.27	11.12	-32.68	-13.00	-19.68	H
1426.19	-35.51	8.17	9.34	-36.68	-13.00	-23.68	V
2139.28	-34.82	9.53	10.42	-35.71	-13.00	-22.71	V
2852.79	-32.58	11.27	11.12	-32.43	-13.00	-19.43	V



LTE Band 17 / 10MHz / QPSK / RB Size 1 Offset 0/ The Worst Test Results for Lowest							
Frequency(MHz)	S G.Lev (dBm)	Ant(dBi)	Loss	PMea	Limit	Margin	Polarity
				(dBm)	(dBm)	(dBm)	
1418.11	-34.41	8.17	9.34	-35.58	-13.00	-22.58	H
2127.38	-34.96	9.53	10.42	-35.85	-13.00	-22.85	H
2836.67	-32.66	11.27	11.12	-32.51	-13.00	-19.51	H
1418.11	-35.39	8.17	9.34	-36.56	-13.00	-23.56	V
2127.38	-33.76	9.53	10.42	-34.65	-13.00	-21.65	V
2836.67	-31.85	11.27	11.12	-31.70	-13.00	-18.70	V
LTE Band 17 / 10MHz / QPSK / RB Size 1 Offset 0/ The Worst Test Results for Middle							
Frequency(MHz)	S G.Lev (dBm)	Ant(dBi)	Loss	PMea	Limit	Margin	Polarity
				(dBm)	(dBm)	(dBm)	
1419.90	-33.66	8.17	9.34	-34.83	-13.00	-21.83	H
2130.23	-34.88	9.53	10.42	-35.77	-13.00	-22.77	H
2840.26	-33.43	11.27	11.12	-33.28	-13.00	-20.28	H
1419.90	-34.63	8.17	9.34	-35.80	-13.00	-22.80	V
2130.23	-34.19	9.53	10.42	-35.08	-13.00	-22.08	V
2840.26	-32.34	11.27	11.12	-32.19	-13.00	-19.19	V
LTE Band 17 / 10MHz / QPSK / RB Size 1 Offset 0/ The Worst Test Results for Highest							
Frequency(MHz)	S G.Lev (dBm)	Ant(dBi)	Loss	PMea	Limit	Margin	Polarity
				(dBm)	(dBm)	(dBm)	
1420.93	-33.66	8.17	9.34	-34.83	-13.00	-21.83	H
2131.84	-34.15	9.53	10.42	-35.04	-13.00	-22.04	H
2842.54	-32.32	11.27	11.12	-32.17	-13.00	-19.17	H
1420.93	-34.54	8.17	9.34	-35.71	-13.00	-22.71	V
2131.84	-35.15	9.53	10.42	-36.04	-13.00	-23.04	V
2842.54	-31.86	11.27	11.12	-31.71	-13.00	-18.71	V



LTE Band 25 / 1.4MHz / QPSK / RB Size 1 Offset 0/ The Worst Test Results for Lowest							
Frequency(MHz)	S G.Lev (dBm)	Ant(dBi)	Loss	PMea	Limit	Margin	Polarity
				(dBm)	(dBm)	(dBm)	
3701.03	-34.77	12.60	12.93	-35.10	-13.00	-22.10	H
5551.98	-34.78	13.10	17.11	-38.79	-13.00	-25.79	H
7402.85	-33.61	11.50	22.20	-44.31	-13.00	-31.31	H
3701.03	-35.10	12.60	12.93	-35.43	-13.00	-22.43	V
5551.98	-35.00	13.10	17.11	-39.01	-13.00	-26.01	V
7402.85	-31.93	11.50	22.20	-42.63	-13.00	-29.63	V
LTE Band 25 / 1.4MHz / QPSK / RB Size 1 Offset 0/ The Worst Test Results for Middle							
Frequency(MHz)	S G.Lev (dBm)	Ant(dBi)	Loss	PMea	Limit	Margin	Polarity
				(dBm)	(dBm)	(dBm)	
3759.90	-34.01	12.60	12.93	-34.34	-13.00	-21.34	H
5639.99	-34.77	13.10	17.11	-38.78	-13.00	-25.78	H
7520.14	-33.23	11.50	22.20	-43.93	-13.00	-30.93	H
3759.90	-35.69	12.60	12.93	-36.02	-13.00	-23.02	V
5639.99	-34.10	13.10	17.11	-38.11	-13.00	-25.11	V
7520.14	-33.02	11.50	22.20	-43.72	-13.00	-30.72	V
LTE Band 25 / 1.4MHz / QPSK / RB Size 1 Offset 0/ The Worst Test Results for Highest							
Frequency(MHz)	S G.Lev (dBm)	Ant(dBi)	Loss	PMea	Limit	Margin	Polarity
				(dBm)	(dBm)	(dBm)	
3818.16	-34.32	12.60	12.93	-34.65	-13.00	-21.65	H
5727.48	-34.29	13.10	17.11	-38.30	-13.00	-25.30	H
7637.18	-33.23	11.50	22.20	-43.93	-13.00	-30.93	H
3818.16	-35.29	12.60	12.93	-35.62	-13.00	-22.62	V
5727.48	-34.88	13.10	17.11	-38.89	-13.00	-25.89	V
7637.18	-32.03	11.50	22.20	-42.73	-13.00	-29.73	V



LTE Band 25 / 3MHz / QPSK / RB Size 1 Offset 0/ The Worst Test Results for Lowest							
Frequency(MHz)	S G.Lev (dBm)	Ant(dBi)	Loss	PMea	Limit	Margin	Polarity
				(dBm)	(dBm)	(dBm)	
3703.24	-34.06	12.60	12.93	-34.39	-13.00	-21.39	H
5554.47	-35.45	13.10	17.11	-39.46	-13.00	-26.46	H
7406.01	-32.23	11.50	22.20	-42.93	-13.00	-29.93	H
3703.24	-35.90	12.60	12.93	-36.23	-13.00	-23.23	V
5554.47	-34.12	13.10	17.11	-38.13	-13.00	-25.13	V
7406.01	-32.40	11.50	22.20	-43.10	-13.00	-30.10	V
LTE Band 25 / 3MHz / QPSK / RB Size 1 Offset 0/ The Worst Test Results for Middle							
Frequency(MHz)	S G.Lev (dBm)	Ant(dBi)	Loss	PMea	Limit	Margin	Polarity
				(dBm)	(dBm)	(dBm)	
3760.05	-34.64	12.60	12.93	-34.97	-13.00	-21.97	H
5640.02	-35.44	13.10	17.11	-39.45	-13.00	-26.45	H
7520.16	-33.05	11.50	22.20	-43.75	-13.00	-30.75	H
3760.05	-35.39	12.60	12.93	-35.72	-13.00	-22.72	V
5640.02	-35.18	13.10	17.11	-39.19	-13.00	-26.19	V
7520.16	-31.95	11.50	22.20	-42.65	-13.00	-29.65	V
LTE Band 25 / 3MHz / QPSK / RB Size 1 Offset 0/ The Worst Test Results for Highest							
Frequency(MHz)	S G.Lev (dBm)	Ant(dBi)	Loss	PMea	Limit	Margin	Polarity
				(dBm)	(dBm)	(dBm)	
3816.90	-34.83	12.60	12.93	-35.16	-13.00	-22.16	H
5725.29	-34.63	13.10	17.11	-38.64	-13.00	-25.64	H
7633.83	-33.18	11.50	22.20	-43.88	-13.00	-30.88	H
3816.90	-34.82	12.60	12.93	-35.15	-13.00	-22.15	V
5725.29	-35.19	13.10	17.11	-39.20	-13.00	-26.20	V
7633.83	-32.45	11.50	22.20	-43.15	-13.00	-30.15	V



LTE Band 25 / 5MHz / QPSK / RB Size 1 Offset 0/ The Worst Test Results for Lowest							
Frequency(MHz)	S G.Lev (dBm)	Ant(dBi)	Loss	PMea	Limit	Margin	Polarity
				(dBm)	(dBm)	(dBm)	
3705.10	-34.53	12.60	12.93	-34.86	-13.00	-21.86	H
5557.33	-34.50	13.10	17.11	-38.51	-13.00	-25.51	H
7410.07	-32.36	11.50	22.20	-43.06	-13.00	-30.06	H
3705.10	-35.63	12.60	12.93	-35.96	-13.00	-22.96	V
5557.33	-34.94	13.10	17.11	-38.95	-13.00	-25.95	V
7410.07	-32.12	11.50	22.20	-42.82	-13.00	-29.82	V
LTE Band 25 / 5MHz / QPSK / RB Size 1 Offset 0/ The Worst Test Results for Middle							
Frequency(MHz)	S G.Lev (dBm)	Ant(dBi)	Loss	PMea	Limit	Margin	Polarity
				(dBm)	(dBm)	(dBm)	
3760.23	-34.03	12.60	12.93	-34.36	-13.00	-21.36	H
5639.92	-34.92	13.10	17.11	-38.93	-13.00	-25.93	H
7519.95	-32.47	11.50	22.20	-43.17	-13.00	-30.17	H
3760.23	-34.64	12.60	12.93	-34.97	-13.00	-21.97	V
5639.92	-33.85	13.10	17.11	-37.86	-13.00	-24.86	V
7519.95	-31.86	11.50	22.20	-42.56	-13.00	-29.56	V
LTE Band 25 / 5MHz / QPSK / RB Size 1 Offset 0/ The Worst Test Results for Highest							
Frequency(MHz)	S G.Lev (dBm)	Ant(dBi)	Loss	PMea	Limit	Margin	Polarity
				(dBm)	(dBm)	(dBm)	
3815.21	-33.53	12.60	12.93	-33.86	-13.00	-20.86	H
5722.27	-35.38	13.10	17.11	-39.39	-13.00	-26.39	H
7630.02	-33.45	11.50	22.20	-44.15	-13.00	-31.15	H
3815.21	-35.03	12.60	12.93	-35.36	-13.00	-22.36	V
5722.27	-34.68	13.10	17.11	-38.69	-13.00	-25.69	V
7630.02	-32.04	11.50	22.20	-42.74	-13.00	-29.74	V



LTE Band 25 / 10MHz / QPSK / RB Size 1 Offset 0/ The Worst Test Results for Lowest							
Frequency(MHz)	S G.Lev (dBm)	Ant(dBi)	Loss	PMea	Limit	Margin	Polarity
				(dBm)	(dBm)	(dBm)	
3710.26	-34.94	12.60	12.93	-35.27	-13.00	-22.27	H
5565.47	-35.21	13.10	17.11	-39.22	-13.00	-26.22	H
7420.06	-33.07	11.50	22.20	-43.77	-13.00	-30.77	H
3710.26	-35.11	12.60	12.93	-35.44	-13.00	-22.44	V
5565.47	-34.63	13.10	17.11	-38.64	-13.00	-25.64	V
7420.06	-32.55	11.50	22.20	-43.25	-13.00	-30.25	V
LTE Band 25 / 10MHz / QPSK / RB Size 1 Offset 0/ The Worst Test Results for Middle							
Frequency(MHz)	S G.Lev (dBm)	Ant(dBi)	Loss	PMea	Limit	Margin	Polarity
				(dBm)	(dBm)	(dBm)	
3760.16	-34.88	12.60	12.93	-35.21	-13.00	-22.21	H
5639.88	-34.38	13.10	17.11	-38.39	-13.00	-25.39	H
7519.87	-32.69	11.50	22.20	-43.39	-13.00	-30.39	H
3760.16	-34.81	12.60	12.93	-35.14	-13.00	-22.14	V
5639.88	-34.08	13.10	17.11	-38.09	-13.00	-25.09	V
7519.87	-32.01	11.50	22.20	-42.71	-13.00	-29.71	V
LTE Band 25 / 10MHz / QPSK / RB Size 1 Offset 0/ The Worst Test Results for Highest							
Frequency(MHz)	S G.Lev (dBm)	Ant(dBi)	Loss	PMea	Limit	Margin	Polarity
				(dBm)	(dBm)	(dBm)	
3810.14	-33.94	12.60	12.93	-34.27	-13.00	-21.27	H
5714.70	-34.87	13.10	17.11	-38.88	-13.00	-25.88	H
7619.88	-33.33	11.50	22.20	-44.03	-13.00	-31.03	H
3810.14	-35.73	12.60	12.93	-36.06	-13.00	-23.06	V
5714.70	-34.87	13.10	17.11	-38.88	-13.00	-25.88	V
7619.88	-31.99	11.50	22.20	-42.69	-13.00	-29.69	V



LTE Band 25 / 15MHz / QPSK / RB Size 1 Offset 0/ The Worst Test Results for Lowest							
Frequency(MHz)	S G.Lev (dBm)	Ant(dBi)	Loss	PMea	Limit	Margin	Polarity
				(dBm)	(dBm)	(dBm)	
3714.91	-34.85	12.60	12.93	-35.18	-13.00	-22.18	H
5572.24	-34.53	13.10	17.11	-38.54	-13.00	-25.54	H
7430.69	-33.08	11.50	22.20	-43.78	-13.00	-30.78	H
3714.91	-34.55	12.60	12.93	-34.88	-13.00	-21.88	V
5572.24	-34.68	13.10	17.11	-38.69	-13.00	-25.69	V
7430.69	-32.19	11.50	22.20	-42.89	-13.00	-29.89	V
LTE Band 25 / 15MHz / QPSK / RB Size 1 Offset 0/ The Worst Test Results for Middle							
Frequency(MHz)	S G.Lev (dBm)	Ant(dBi)	Loss	PMea	Limit	Margin	Polarity
				(dBm)	(dBm)	(dBm)	
3760.26	-33.62	12.60	12.93	-33.95	-13.00	-20.95	H
5640.16	-35.18	13.10	17.11	-39.19	-13.00	-26.19	H
7520.28	-32.63	11.50	22.20	-43.33	-13.00	-30.33	H
3760.26	-34.77	12.60	12.93	-35.10	-13.00	-22.10	V
5640.16	-35.17	13.10	17.11	-39.18	-13.00	-26.18	V
7520.28	-33.04	11.50	22.20	-43.74	-13.00	-30.74	V
LTE Band 25 / 15MHz / QPSK / RB Size 1 Offset 0/ The Worst Test Results for Highest							
Frequency(MHz)	S G.Lev (dBm)	Ant(dBi)	Loss	PMea	Limit	Margin	Polarity
				(dBm)	(dBm)	(dBm)	
3805.01	-34.56	12.60	12.93	-34.89	-13.00	-21.89	H
5707.39	-34.02	13.10	17.11	-38.03	-13.00	-25.03	H
7610.26	-33.61	11.50	22.20	-44.31	-13.00	-31.31	H
3805.01	-34.69	12.60	12.93	-35.02	-13.00	-22.02	V
5707.39	-33.85	13.10	17.11	-37.86	-13.00	-24.86	V
7610.26	-32.37	11.50	22.20	-43.07	-13.00	-30.07	V



LTE Band 25 / 20MHz / QPSK / RB Size 1 Offset 0/ The Worst Test Results for Lowest							
Frequency(MHz)	S G.Lev (dBm)	Ant(dBi)	Loss	PMea	Limit	Margin	Polarity
				(dBm)	(dBm)	(dBm)	
3720.13	-34.18	12.60	12.93	-34.51	-13.00	-21.51	H
5580.17	-35.43	13.10	17.11	-39.44	-13.00	-26.44	H
7439.85	-32.33	11.50	22.20	-43.03	-13.00	-30.03	H
3720.13	-34.88	12.60	12.93	-35.21	-13.00	-22.21	V
5580.17	-34.13	13.10	17.11	-38.14	-13.00	-25.14	V
7439.85	-32.99	11.50	22.20	-43.69	-13.00	-30.69	V
LTE Band 25 / 20MHz / QPSK / RB Size 1 Offset 0/ The Worst Test Results for Middle							
Frequency(MHz)	S G.Lev (dBm)	Ant(dBi)	Loss	PMea	Limit	Margin	Polarity
				(dBm)	(dBm)	(dBm)	
3759.82	-34.23	12.60	12.93	-34.56	-13.00	-21.56	H
5639.81	-35.02	13.10	17.11	-39.03	-13.00	-26.03	H
7520.06	-33.64	11.50	22.20	-44.34	-13.00	-31.34	H
3759.82	-34.59	12.60	12.93	-34.92	-13.00	-21.92	V
5639.81	-34.66	13.10	17.11	-38.67	-13.00	-25.67	V
7520.06	-32.50	11.50	22.20	-43.20	-13.00	-30.20	V
LTE Band 25 / 20MHz / QPSK / RB Size 1 Offset 0/ The Worst Test Results for Highest							
Frequency(MHz)	S G.Lev (dBm)	Ant(dBi)	Loss	PMea	Limit	Margin	Polarity
				(dBm)	(dBm)	(dBm)	
3799.75	-33.76	12.60	12.93	-34.09	-13.00	-21.09	H
5700.10	-35.13	13.10	17.11	-39.14	-13.00	-26.14	H
7600.06	-32.73	11.50	22.20	-43.43	-13.00	-30.43	H
3799.75	-35.57	12.60	12.93	-35.90	-13.00	-22.90	V
5700.10	-34.53	13.10	17.11	-38.54	-13.00	-25.54	V
7600.06	-33.14	11.50	22.20	-43.84	-13.00	-30.84	V



LTE Band 26 / 1.4MHz / QPSK / RB Size 1 Offset 0/ The Worst Test Results for Lowest							
Frequency(MHz)	S G.Lev (dBm)	Ant(dBi)	Loss	PMea	Limit	Margin	Polarity
				(dBm)	(dBm)	(dBm)	
1649.11	-34.42	9.56	9.72	-34.58	-13.00	-21.58	H
2473.26	-35.36	10.50	10.86	-35.72	-13.00	-22.72	H
3298.73	-33.32	12.78	11.57	-32.11	-13.00	-19.11	H
1649.11	-34.88	9.56	9.72	-35.04	-13.00	-22.04	V
2473.26	-35.09	10.50	10.86	-35.45	-13.00	-22.45	V
3298.73	-31.99	12.78	11.57	-30.78	-13.00	-17.78	V
LTE Band 26 / 1.4MHz / QPSK / RB Size 1 Offset 0/ The Worst Test Results for Middle							
Frequency(MHz)	S G.Lev (dBm)	Ant(dBi)	Loss	PMea	Limit	Margin	Polarity
				(dBm)	(dBm)	(dBm)	
1672.86	-34.33	9.56	9.72	-34.49	-13.00	-21.49	H
2509.21	-34.35	10.50	10.86	-34.71	-13.00	-21.71	H
3345.97	-33.28	12.78	11.57	-32.07	-13.00	-19.07	H
1672.86	-35.98	9.56	9.72	-36.14	-13.00	-23.14	V
2509.21	-34.60	10.50	10.86	-34.96	-13.00	-21.96	V
3345.97	-32.53	12.78	11.57	-31.32	-13.00	-18.32	V
LTE Band 26 / 1.4MHz / QPSK / RB Size 1 Offset 0/ The Worst Test Results for Highest							
Frequency(MHz)	S G.Lev (dBm)	Ant(dBi)	Loss	PMea	Limit	Margin	Polarity
				(dBm)	(dBm)	(dBm)	
1696.47	-33.83	9.56	9.72	-33.99	-13.00	-20.99	H
2544.85	-34.91	10.50	10.86	-35.27	-13.00	-22.27	H
3393.02	-32.95	12.78	11.57	-31.74	-13.00	-18.74	H
1696.47	-35.99	9.56	9.72	-36.15	-13.00	-23.15	V
2544.85	-35.23	10.50	10.86	-35.59	-13.00	-22.59	V
3393.02	-32.72	12.78	11.57	-31.51	-13.00	-18.51	V



LTE Band 26 / 3MHz / QPSK / RB Size 1 Offset 0/ The Worst Test Results for Lowest							
Frequency(MHz)	S G.Lev (dBm)	Ant(dBi)	Loss	PMea	Limit	Margin	Polarity
				(dBm)	(dBm)	(dBm)	
1651.27	-34.53	9.56	9.72	-34.69	-13.00	-21.69	H
2476.52	-34.22	10.50	10.86	-34.58	-13.00	-21.58	H
3301.72	-32.59	12.78	11.57	-31.38	-13.00	-18.38	H
1651.27	-35.68	9.56	9.72	-35.84	-13.00	-22.84	V
2476.52	-34.23	10.50	10.86	-34.59	-13.00	-21.59	V
3301.72	-32.07	12.78	11.57	-30.86	-13.00	-17.86	V
LTE Band 26 / 3MHz / QPSK / RB Size 1 Offset 0/ The Worst Test Results for Middle							
Frequency(MHz)	S G.Lev (dBm)	Ant(dBi)	Loss	PMea	Limit	Margin	Polarity
				(dBm)	(dBm)	(dBm)	
1673.14	-34.10	9.56	9.72	-34.26	-13.00	-21.26	H
2509.25	-34.95	10.50	10.86	-35.31	-13.00	-22.31	H
3346.15	-32.28	12.78	11.57	-31.07	-13.00	-18.07	H
1673.14	-35.67	9.56	9.72	-35.83	-13.00	-22.83	V
2509.25	-33.84	10.50	10.86	-34.20	-13.00	-21.20	V
3346.15	-31.73	12.78	11.57	-30.52	-13.00	-17.52	V
LTE Band 26 / 3MHz / QPSK / RB Size 1 Offset 0/ The Worst Test Results for Highest							
Frequency(MHz)	S G.Lev (dBm)	Ant(dBi)	Loss	PMea	Limit	Margin	Polarity
				(dBm)	(dBm)	(dBm)	
1695.66	-34.75	9.56	9.72	-34.91	-13.00	-21.91	H
2542.50	-34.50	10.50	10.86	-34.86	-13.00	-21.86	H
3390.16	-32.49	12.78	11.57	-31.28	-13.00	-18.28	H
1695.66	-34.56	9.56	9.72	-34.72	-13.00	-21.72	V
2542.50	-35.15	10.50	10.86	-35.51	-13.00	-22.51	V
3390.16	-32.84	12.78	11.57	-31.63	-13.00	-18.63	V



LTE Band 26 / 5MHz / QPSK / RB Size 1 Offset 0/ The Worst Test Results for Lowest							
Frequency(MHz)	S G.Lev (dBm)	Ant(dBi)	Loss	PMea	Limit	Margin	Polarity
				(dBm)	(dBm)	(dBm)	
1653.01	-34.81	9.56	9.72	-34.97	-13.00	-21.97	H
2479.33	-35.16	10.50	10.86	-35.52	-13.00	-22.52	H
3306.81	-33.27	12.78	11.57	-32.06	-13.00	-19.06	H
1653.01	-35.26	9.56	9.72	-35.42	-13.00	-22.42	V
2479.33	-34.17	10.50	10.86	-34.53	-13.00	-21.53	V
3306.81	-33.13	12.78	11.57	-31.92	-13.00	-18.92	V
LTE Band 26 / 5MHz / QPSK / RB Size 1 Offset 0/ The Worst Test Results for Middle							
Frequency(MHz)	S G.Lev (dBm)	Ant(dBi)	Loss	PMea	Limit	Margin	Polarity
				(dBm)	(dBm)	(dBm)	
1672.92	-34.21	9.56	9.72	-34.37	-13.00	-21.37	H
2508.82	-34.08	10.50	10.86	-34.44	-13.00	-21.44	H
3345.89	-32.64	12.78	11.57	-31.43	-13.00	-18.43	H
1672.92	-35.30	9.56	9.72	-35.46	-13.00	-22.46	V
2508.82	-33.97	10.50	10.86	-34.33	-13.00	-21.33	V
3345.89	-33.06	12.78	11.57	-31.85	-13.00	-18.85	V
LTE Band 26 / 5MHz / QPSK / RB Size 1 Offset 0/ The Worst Test Results for Highest							
Frequency(MHz)	S G.Lev (dBm)	Ant(dBi)	Loss	PMea	Limit	Margin	Polarity
				(dBm)	(dBm)	(dBm)	
1693.68	-34.48	9.56	9.72	-34.64	-13.00	-21.64	H
2539.37	-34.90	10.50	10.86	-35.26	-13.00	-22.26	H
3386.23	-32.39	12.78	11.57	-31.18	-13.00	-18.18	H
1693.68	-35.13	9.56	9.72	-35.29	-13.00	-22.29	V
2539.37	-34.94	10.50	10.86	-35.30	-13.00	-22.30	V
3386.23	-32.27	12.78	11.57	-31.06	-13.00	-18.06	V



LTE Band 26 / 10MHz / QPSK / RB Size 1 Offset 0/ The Worst Test Results for Lowest							
Frequency(MHz)	S G.Lev (dBm)	Ant(dBi)	Loss	PMea	Limit	Margin	Polarity
				(dBm)	(dBm)	(dBm)	
1657.78	-33.63	9.56	9.72	-33.79	-13.00	-20.79	H
2486.57	-35.31	10.50	10.86	-35.67	-13.00	-22.67	H
3315.86	-32.21	12.78	11.57	-31.00	-13.00	-18.00	H
1657.78	-34.62	9.56	9.72	-34.78	-13.00	-21.78	V
2486.57	-33.93	10.50	10.86	-34.29	-13.00	-21.29	V
3315.86	-32.41	12.78	11.57	-31.20	-13.00	-18.20	V
LTE Band 26 / 10MHz / QPSK / RB Size 1 Offset 0/ The Worst Test Results for Middle							
Frequency(MHz)	S G.Lev (dBm)	Ant(dBi)	Loss	PMea	Limit	Margin	Polarity
				(dBm)	(dBm)	(dBm)	
1673.16	-34.15	9.56	9.72	-34.31	-13.00	-21.31	H
2509.06	-34.10	10.50	10.86	-34.46	-13.00	-21.46	H
3345.98	-32.93	12.78	11.57	-31.72	-13.00	-18.72	H
1673.16	-35.34	9.56	9.72	-35.50	-13.00	-22.50	V
2509.06	-35.02	10.50	10.86	-35.38	-13.00	-22.38	V
3345.98	-32.36	12.78	11.57	-31.15	-13.00	-18.15	V
LTE Band 26 / 10MHz / QPSK / RB Size 1 Offset 0/ The Worst Test Results for Highest							
Frequency(MHz)	S G.Lev (dBm)	Ant(dBi)	Loss	PMea	Limit	Margin	Polarity
				(dBm)	(dBm)	(dBm)	
1688.60	-34.22	9.56	9.72	-34.38	-13.00	-21.38	H
2532.48	-35.22	10.50	10.86	-35.58	-13.00	-22.58	H
3375.97	-32.89	12.78	11.57	-31.68	-13.00	-18.68	H
1688.60	-35.11	9.56	9.72	-35.27	-13.00	-22.27	V
2532.48	-34.30	10.50	10.86	-34.66	-13.00	-21.66	V
3375.97	-31.78	12.78	11.57	-30.57	-13.00	-17.57	V



LTE Band 26 / 15MHz / QPSK / RB Size 1 Offset 0/ The Worst Test Results for Lowest							
Frequency(MHz)	S G.Lev (dBm)	Ant(dBi)	Loss	PMea	Limit	Margin	Polarity
				(dBm)	(dBm)	(dBm)	
1663.21	-33.52	9.56	9.72	-33.68	-13.00	-20.68	H
2494.32	-34.51	10.50	10.86	-34.87	-13.00	-21.87	H
3325.48	-33.58	12.78	11.57	-32.37	-13.00	-19.37	H
1663.21	-34.52	9.56	9.72	-34.68	-13.00	-21.68	V
2494.32	-34.42	10.50	10.86	-34.78	-13.00	-21.78	V
3325.48	-33.18	12.78	11.57	-31.97	-13.00	-18.97	V
LTE Band 26 / 15MHz / QPSK / RB Size 1 Offset 0/ The Worst Test Results for Middle							
Frequency(MHz)	S G.Lev (dBm)	Ant(dBi)	Loss	PMea	Limit	Margin	Polarity
				(dBm)	(dBm)	(dBm)	
1673.17	-34.00	9.56	9.72	-34.16	-13.00	-21.16	H
2508.80	-35.20	10.50	10.86	-35.56	-13.00	-22.56	H
3345.89	-32.70	12.78	11.57	-31.49	-13.00	-18.49	H
1673.17	-35.02	9.56	9.72	-35.18	-13.00	-22.18	V
2508.80	-34.63	10.50	10.86	-34.99	-13.00	-21.99	V
3345.89	-33.07	12.78	11.57	-31.86	-13.00	-18.86	V
LTE Band 26 / 15MHz / QPSK / RB Size 1 Offset 0/ The Worst Test Results for Highest							
Frequency(MHz)	S G.Lev (dBm)	Ant(dBi)	Loss	PMea	Limit	Margin	Polarity
				(dBm)	(dBm)	(dBm)	
1683.45	-33.98	9.56	9.72	-34.14	-13.00	-21.14	H
2524.32	-34.12	10.50	10.86	-34.48	-13.00	-21.48	H
3366.47	-32.25	12.78	11.57	-31.04	-13.00	-18.04	H
1683.45	-35.37	9.56	9.72	-35.53	-13.00	-22.53	V
2524.32	-34.22	10.50	10.86	-34.58	-13.00	-21.58	V
3366.47	-31.81	12.78	11.57	-30.60	-13.00	-17.60	V



LTE Band 26 / 1.4MHz / QPSK / RB Size 1 Offset 0/ The Worst Test Results for Lowest							
Frequency(MHz)	S G.Lev (dBm)	Ant(dBi)	Loss	PMea	Limit	Margin	Polarity
				(dBm)	(dBm)	(dBm)	
1629.21	-34.89	9.56	9.72	-35.05	-13.00	-22.05	H
2444.35	-34.03	10.50	10.86	-34.39	-13.00	-21.39	H
3258.51	-33.21	12.78	11.57	-32.00	-13.00	-19.00	H
1629.21	-34.55	9.56	9.72	-34.71	-13.00	-21.71	V
2444.35	-34.75	10.50	10.86	-35.11	-13.00	-22.11	V
3258.51	-32.92	12.78	11.57	-31.71	-13.00	-18.71	V
LTE Band 26 / 1.4MHz / QPSK / RB Size 1 Offset 0/ The Worst Test Results for Middle							
Frequency(MHz)	S G.Lev (dBm)	Ant(dBi)	Loss	PMea	Limit	Margin	Polarity
				(dBm)	(dBm)	(dBm)	
1638.16	-33.98	9.56	9.72	-34.14	-13.00	-21.14	H
2457.20	-34.09	10.50	10.86	-34.45	-13.00	-21.45	H
3276.04	-33.14	12.78	11.57	-31.93	-13.00	-18.93	H
1638.16	-34.74	9.56	9.72	-34.90	-13.00	-21.90	V
2457.20	-35.10	10.50	10.86	-35.46	-13.00	-22.46	V
3276.04	-32.20	12.78	11.57	-30.99	-13.00	-17.99	V
LTE Band 26 / 1.4MHz / QPSK / RB Size 1 Offset 0/ The Worst Test Results for Highest							
Frequency(MHz)	S G.Lev (dBm)	Ant(dBi)	Loss	PMea	Limit	Margin	Polarity
				(dBm)	(dBm)	(dBm)	
1646.73	-33.95	9.56	9.72	-34.11	-13.00	-21.11	H
2469.89	-35.05	10.50	10.86	-35.41	-13.00	-22.41	H
3292.75	-33.65	12.78	11.57	-32.44	-13.00	-19.44	H
1646.73	-36.01	9.56	9.72	-36.17	-13.00	-23.17	V
2469.89	-33.92	10.50	10.86	-34.28	-13.00	-21.28	V
3292.75	-33.15	12.78	11.57	-31.94	-13.00	-18.94	V



LTE Band 26 / 3MHz / QPSK / RB Size 1 Offset 0/ The Worst Test Results for Lowest							
Frequency(MHz)	S G.Lev (dBm)	Ant(dBi)	Loss	PMea	Limit	Margin	Polarity
				(dBm)	(dBm)	(dBm)	
1631.30	-33.58	9.56	9.72	-33.74	-13.00	-20.74	H
2446.64	-35.23	10.50	10.86	-35.59	-13.00	-22.59	H
3261.86	-32.23	12.78	11.57	-31.02	-13.00	-18.02	H
1631.30	-35.71	9.56	9.72	-35.87	-13.00	-22.87	V
2446.64	-34.04	10.50	10.86	-34.40	-13.00	-21.40	V
3261.86	-32.03	12.78	11.57	-30.82	-13.00	-17.82	V
LTE Band 26 / 3MHz / QPSK / RB Size 1 Offset 0/ The Worst Test Results for Middle							
Frequency(MHz)	S G.Lev (dBm)	Ant(dBi)	Loss	PMea	Limit	Margin	Polarity
				(dBm)	(dBm)	(dBm)	
1637.91	-33.72	9.56	9.72	-33.88	-13.00	-20.88	H
2457.24	-35.43	10.50	10.86	-35.79	-13.00	-22.79	H
3276.26	-32.75	12.78	11.57	-31.54	-13.00	-18.54	H
1637.91	-35.85	9.56	9.72	-36.01	-13.00	-23.01	V
2457.24	-33.79	10.50	10.86	-34.15	-13.00	-21.15	V
3276.26	-32.88	12.78	11.57	-31.67	-13.00	-18.67	V
LTE Band 26 / 3MHz / QPSK / RB Size 1 Offset 0/ The Worst Test Results for Highest							
Frequency(MHz)	S G.Lev (dBm)	Ant(dBi)	Loss	PMea	Limit	Margin	Polarity
				(dBm)	(dBm)	(dBm)	
1644.98	-33.73	9.56	9.72	-33.89	-13.00	-20.89	H
2467.43	-34.88	10.50	10.86	-35.24	-13.00	-22.24	H
3290.22	-32.18	12.78	11.57	-30.97	-13.00	-17.97	H
1644.98	-35.77	9.56	9.72	-35.93	-13.00	-22.93	V
2467.43	-34.20	10.50	10.86	-34.56	-13.00	-21.56	V
3290.22	-32.70	12.78	11.57	-31.49	-13.00	-18.49	V



LTE Band 26 / 5MHz / QPSK / RB Size 1 Offset 0/ The Worst Test Results for Lowest							
Frequency(MHz)	S G.Lev (dBm)	Ant(dBi)	Loss	PMea	Limit	Margin	Polarity
				(dBm)	(dBm)	(dBm)	
1632.75	-34.80	9.56	9.72	-34.96	-13.00	-21.96	H
2448.88	-34.83	10.50	10.86	-35.19	-13.00	-22.19	H
3266.00	-32.52	12.78	11.57	-31.31	-13.00	-18.31	H
1632.75	-35.43	9.56	9.72	-35.59	-13.00	-22.59	V
2448.88	-34.08	10.50	10.86	-34.44	-13.00	-21.44	V
3266.00	-31.80	12.78	11.57	-30.59	-13.00	-17.59	V
LTE Band 26 / 5MHz / QPSK / RB Size 1 Offset 0/ The Worst Test Results for Middle							
Frequency(MHz)	S G.Lev (dBm)	Ant(dBi)	Loss	PMea	Limit	Margin	Polarity
				(dBm)	(dBm)	(dBm)	
1643.01	-33.68	9.56	9.72	-33.84	-13.00	-20.84	H
2464.13	-35.13	10.50	10.86	-35.49	-13.00	-22.49	H
3286.08	-33.37	12.78	11.57	-32.16	-13.00	-19.16	H
1643.01	-35.27	9.56	9.72	-35.43	-13.00	-22.43	V
2464.13	-35.06	10.50	10.86	-35.42	-13.00	-22.42	V
3286.08	-31.90	12.78	11.57	-30.69	-13.00	-17.69	V
LTE Band 26 / 5MHz / QPSK / RB Size 1 Offset 0/ The Worst Test Results for Highest							
Frequency(MHz)	S G.Lev (dBm)	Ant(dBi)	Loss	PMea	Limit	Margin	Polarity
				(dBm)	(dBm)	(dBm)	
1693.44	-33.56	9.56	9.72	-33.72	-13.00	-20.72	H
2539.08	-34.33	10.50	10.86	-34.69	-13.00	-21.69	H
3386.09	-32.41	12.78	11.57	-31.20	-13.00	-18.20	H
1693.44	-35.30	9.56	9.72	-35.46	-13.00	-22.46	V
2539.08	-33.86	10.50	10.86	-34.22	-13.00	-21.22	V
3386.09	-32.83	12.78	11.57	-31.62	-13.00	-18.62	V



LTE Band 26 / 10MHz / QPSK / RB Size 1 Offset 0/ The Worst Test Results for Middle							
Frequency(MHz)	S G.Lev (dBm)	Ant(dBi)	Loss	PMea (dBm)	Limit (dBm)	Margin (dBm)	Polarity
1638.04	-34.20	9.56	9.72	-34.36	-13.00	-21.36	H
2457.09	-34.24	10.50	10.86	-34.60	-13.00	-21.60	H
3275.82	-32.23	12.78	11.57	-31.02	-13.00	-18.02	H
1638.04	-35.08	9.56	9.72	-35.24	-13.00	-22.24	V
2457.09	-34.85	10.50	10.86	-35.21	-13.00	-22.21	V
3275.82	-32.69	12.78	11.57	-31.48	-13.00	-18.48	V



APPENDIX-PHOTOS OF TEST SETUP

Note: See test photos in setup photo document for the actual connections between Product and support equipment.

*****END OF THE REPORT*****