



TEST REPORT

FCC ID: 2AAHW-3DP-25A

Applicant : Beijing TierTime Technolgy co., Ltd
Address : No.18 Yanqi Avenue, Yanqi Economic Development Area, Huairou District, Beijing, 101407, P. R. China

Equipment Under Test(EUT):

Name : UP BOX+
Model : 3DP-25-4F, 3DP-25-4G, 3DP-25-4H,
3DP-25-4J, 3DP-25-4K

In Accordance with: FCC PART 15, SUBPART C : 2015 (Section 15.247)
ANSI C63.4:2014 ; ANSI C63.10:2013

Report No : T1860894 06
Date of Test : May 24- June 01, 2016
Date of Issue : June 14, 2016

Test Result : PASS

Test Result: **PASS**

In the configuration tested, the EUT complied with the standards specified above

Authorized Signature

(Mark Zhu)
General Manager

The manufacture should ensure that all the products in series production are in conformity with the product sample detailed in this report. If the product in this report is used in any configuration other than that detailed in the report, the manufacturer must ensure the new system complies with all relevant standards. Any mention of Shenzhen Alpha Product Testing Co., Ltd. Or test done by Shenzhen Alpha Product Testing Co., Ltd. Approvals in connection with, distribution or use of the product described in this report must be approved by Shenzhen Alpha Product Testing Co., Ltd. Approvals in writing.

TABLE OF CONTENT

Description	Page
1 General Information -----	4
1.1 Description of Device (EUT)-----	4
1.2 Description of Test Facility-----	5
2 EMC Equipment List -----	5
3 Test Procedure -----	6
4 Summary of Measurement -----	7
4.1 Summary of test result-----	7
4.2 Test connection-----	8
4.3 Assistant equipment used for test-----	8
4.4 Test mode-----	8
4.5 Channel list-----	9
4.6 Test Conditions-----	9
4.7 Measurement Uncertainty (95% confidence levels, k=2)-----	9
5 Spurious Emission -----	10
5.1 Radiation Emission-----	10
5.1.1 Radiation Emission Limits(15.209)-----	10
5.1.2 Test Setup-----	10
5.1.3 Test Procedure-----	12
5.1.4 Test Equipment Setting For emission test Result-----	12
5.1.5 Test Condition-----	13
5.1.6 Test Result-----	13
6 POWER LINE CONDUCTED EMISSION -----	25
6.1 Conducted Emission Limits(15.207)-----	25
6.2 Test Setup-----	25
6.3 Test Procedure-----	26
6.4 Test Results-----	27
7 Conducted Maximum Output Power -----	29
7.1 Test limit-----	29
7.2 Test Procedure-----	29
7.3 Test Setup-----	29
7.4 Test Results-----	29
8 PEAK POWER SPECTRAL DENSITY -----	31
8.1 Test limit-----	31
8.2 Method of measurement-----	31
8.3 Test Setup-----	31
8.4 Test Results-----	32
9 Bandwidth -----	38
9.1 Test limit-----	38
9.2 Method of measurement-----	38
9.3 Test Setup-----	38
9.4 Test Results-----	38
10 Band Edge Check -----	45
10.1 Test limit-----	45
10.2 Test Procedure-----	45
10.3 Test Setup-----	45

10.4	Test Result -----	45
11	Antenna Requirement -----	55
11.1	Standard Requirement-----	55
11.2	Antenna Connected Construction-----	55
11.3	Result-----	55
12	Test setup photo-----	56
13	Photos of EUT-----	58

1 General Information

1.1 Description of Device (EUT)

Trade Name : N/A

EUT : UP BOX+

Model No. : 3DP-25-4F, 3DP-25-4G, 3DP-25-4H, 3DP-25-4J, 3DP-25-4K

DIFF : Only differ in model number.

Antenna Type : Integrated Antenna, Maximum Gain is 1dBi

Operation : IEEE 802.11b/g: 2412MHz-2462MHz

Frequency : IEEE 802.11n HT20: 2412MHz-2462MHz

Channel number : IEEE 802.11b/g:11Channels
IEEE 802.11n HT20: 11 Channels
IEEE 802.11b: DSSS(CCK,DQPSK,DBPSK)

Modulation type : IEEE 802.11g: OFDM(64QAM, 16QAM, QPSK, BPSK)
IEEE 802.11n :OFDM(64QAM, 16QAM, QPSK, BPSK)

Power Supply : DC 24V from adapter

Adapter : FSP220-AAAN2

Applicant : Beijing TierTime Technolgoy co., Ltd

Address : No.18 Yanqi Avenue, Yanqi Economic Development Area,
Huairou District, Beijing, 101407, P. R. China

Manufacturer : Beijing TierTime Technolgoy co., Ltd

Address : No.18 Yanqi Avenue, Yanqi Economic Development Area,
Huairou District, Beijing, 101407, P. R. China

1.2 Description of Test Facility

Shenzhen Alpha Product Testing Co., Ltd
 Building B, East Area of Nanchang Second, Industrial Zone, Gushu 2nd Road,
 Bao'an, Shenzhen, China

March 25, 2015 File on Federal Communication Commission
 Registration Number: 203110

July 18, 2014 Certificated by IC
 Registration Number: 12135A

2 EMC Equipment List

Equipment	Manufacture	Model No.	Serial No.	Last cal. Due to	Cal Interval
3m Semi-Anechoic	CHENYU	N/A	N/A	2018.01.18	2Year
Spectrum analyzer	Agilent	E4407B	MY46185649	2017.01.16	1Year
L.I.S.N.#1	Schwarzbeck	NSLK8126	8126466	2017.01.16	1Year
Receiver	R&S	ESCI	101165	2017.01.16	1Year
Bilog Antenna	SCHWARZBECK	VULB 9168	VULB9168-438	2018.01.18	2Year
Horn Antenna	SCHWARZBECK	BBHA 9120 D	BBHA 9120 D(1201)	2017.01.20	2Year
Cable	Resenberger	N/A	No.1	2017.01.16	1Year
Cable	SCHWARZBECK	N/A	No.2	2017.01.16	1Year
Cable	SCHWARZBECK	N/A	No.3	2017.01.16	1Year
Pre-amplifier	HP	HP8347A	2834A00455	2017.01.18	1Year
Pre-amplifier	Agilent	8449B	3008A02664	2017.01.18	1Year
vector Signal Generator	Agilent	N5182A	MY49060042	2016.11.16	1 Year
vector Signal Generator	Agilent	E4438C	US44271917	2016.11.16	1 Year
X-series USB Peak and Average	Agilent	U2021XA	MY54080020	2016.11.16	1 Year

Power Sensor					
X-series USB Peak and Average Power Sensor	Agilent	U2021XA	MY54110001	2016.11.16	1 Year
Signal Analyzer	Agilent	N9020A	MY48030494	2016.11.16	1 Year

3 Test Procedure

POWER LINE CONDUCTED INTERFERENCE: The test procedure used was ANSI Standard ANSI C63.10:2013 using a 50 u H LISN. Both Lines were observed. The bandwidth of the receiver was 10kHz with an appropriate sweep speed. The ambient temperature of the EUT was 25°C with a humidity of 58%.

RADIATION INTERFERENCE: The test procedure used was ANSI Standard ANSI C63.10:2013 using a ANRITSU spectrum analyzer with a pre-selector. The analyzer was calibrated in dB above a micro volt at the output of the antenna. The resolution bandwidth was 100kHz and the video bandwidth was 300 kHz up to 1 GHz and 1 MHz with a video BW of 3MHz above 1 GHz. The ambient temperature of the EUT was 25°C with a humidity of 58%.

FORMULA OF CONVERSION FACTORS: The Field Strength at 3m was established by adding the meter reading of the spectrum analyzer (which is set to read in units of dBuV) to the antenna correction factor supplied by the antenna manufacturer and cable loss. The antenna correction factors and cable loss are stated in terms of dB. The gain of the Pre-selector was accounted for in the Spectrum Analyzer Meter Reading.

Example:

Freq (MHz) METER READING + ACF + CABLE = FS

33.20 dBuV + 10.36 dB + 0.9 dB= 44.46 dBuV/m @ 3m

ANSI STANDARD ANSI C63.10:2013 MEASUREMENT PROCEDURES: The EUT was placed on a table 80 cm high and with dimensions of 1m by 1.5m. The EUT was placed in the center of the table (1.5m side). The table used for radiated measurements is capable of continuous rotation. When an emission was found, the table was rotated to produce the maximum signal strength. At this point, the antenna was raised and lowered from 1m to 4m. The antenna was placed in both the horizontal and vertical planes. The situation was similar for the conducted measurement except that the table did not rotate. The EUT was setup as described in ANSI Standard ANSI C63.10:2013 with the EUT 40 cm from the vertical ground wall.

4 Summary of Measurement

4.1 Summary of test result

Test Item	Test Requirement	Standards Paragraph	Result
Spurious Emission	FCC PART 15:2015	Section 15.247&15.209	Compliance
Conduction Emission	FCC PART 15:2015	Section 15.207	Compliance
Bandwidth Test	FCC PART 15:2015	Section 15.247	Compliance
Peak Power	FCC PART 15:2015	Section 15.247	Compliance
Power Density	FCC PART 15:2015	Section 15.247	Compliance
Band Edge	FCC PART 15:2015	Section 15.247	Compliance
Antenna Requirement	FCC PART 15:2015	Section 15.203	Compliance

Note: The EUT has been tested as an independent unit. And Continual Transmitting in maximum power, Test had been referenced to the kdb 558074 D01 DTS Meas Guidance v03r04 .

4.2 Test connection

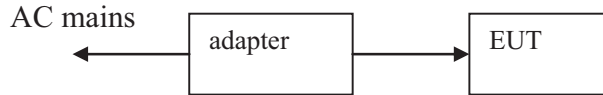

4.3 Assistant equipment used for test

Description	: Adapter
Manufacturer	: NIL
Model No.	: FSP220-AAAN2
Input	: AC 100-240V, 50-60Hz, 3.0A
Output	: DC 24V, 9.16A

4.4 Test mode

Dutycycle :100%			
Keeping TX			
Mode	data rate (Mbps)(see Note)	Channel	Frequency (MHz)
IEEE 802.11b	1	Low :CH1	2412
	1	Middle: CH6	2437
	1	High: CH11	2462
IEEE 802.11g	6	Low :CH1	2412
	6	Middle: CH6	2437
	6	High: CH11	2462
IEEE 802.11 n/HT20 with 2.4G	6.5	Low :CH1	2412
	6.5	Middle: CH6	2437
	6.5	High: CH11	2462

Note: According exploratory test, EUT will have maximum output power in those data rate. so those data rate were used for all test.

4.5 Channel list

For IEEE 802.11b/g and IEEE 802.11n/HT20 with 2.4G					
Channel	Frequency (MHz)	Channel	Frequency (MHz)	Channel	Frequency (MHz)
CH1	2412	CH5	2432	CH9	2452
CH2	2417	CH6	2437	CH10	2457
CH3	2422	CH7	2442	CH11	2462
CH4	2427	CH8	2447		

4.6 Test Conditions

Temperature range	21-25°C
Humidity range	40-75%
Pressure range	86-106kPa

4.7 Measurement Uncertainty (95% confidence levels, k=2)

Item	MU	Remark
Uncertainty for Power point Conducted Emissions Test	2.71dB	
Uncertainty for Radiation Emission test in 3m chamber (30MHz to 1GHz)	3.90 dB	Polarize: V
	3.92dB	Polarize: H
Uncertainty for Radiation Emission test in 3m chamber (1GHz to 25GHz)	4.26 dB	Polarize: H
	4.28 dB	Polarize: V
Uncertainty for conducted RF Power	0.16dB	

5 Spurious Emission

5.1 Radiation Emission

5.1.1 Radiation Emission Limits(15.209)

Frequencies (MHz)	Field Strength (micorvolts/meter)	Measurement Distance (meters)
0.009~0.490	2400/F(KHz)	300
0.490~1.705	24000/F(KHz)	30
1.705~30.0	30	30
30~88	100	3
88~216	150	3
216~960	200	3
Above 960	500	3

Harmonic emissions limits comply with below 54 dBuV/m at 3m. Other emissions radiated outside of the specified frequency bands, except for harmonics, shall be attenuated by at least 50 dB below the level of the fundamental or comply with the radiated emissions limits specified in section 15.209(a) limit in the table below has to be followed.

NOTE:

- a) The tighter limit applies at the band edges.
- b) Emission Level(dB uV/m)=20log Emission Level(uv/m)

5.1.2 Test Setup

See the next page

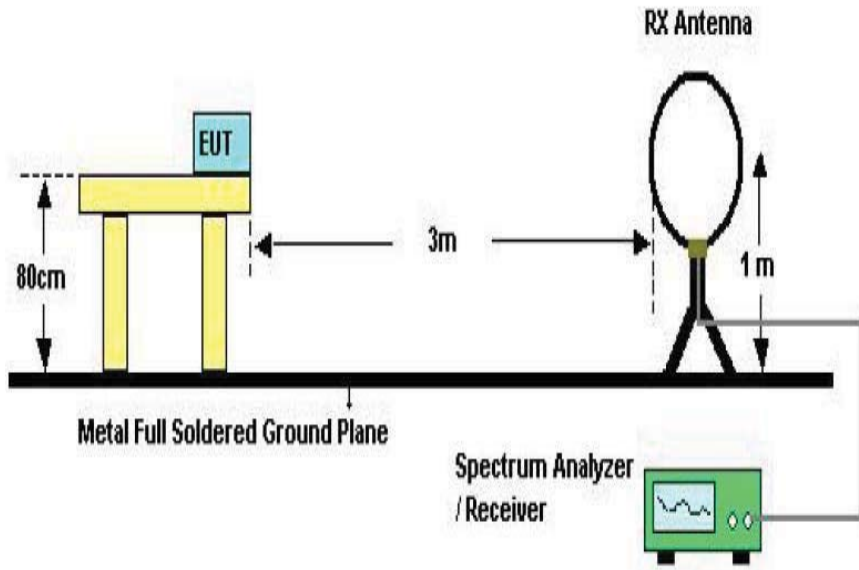

Below 30MHz Test Setup

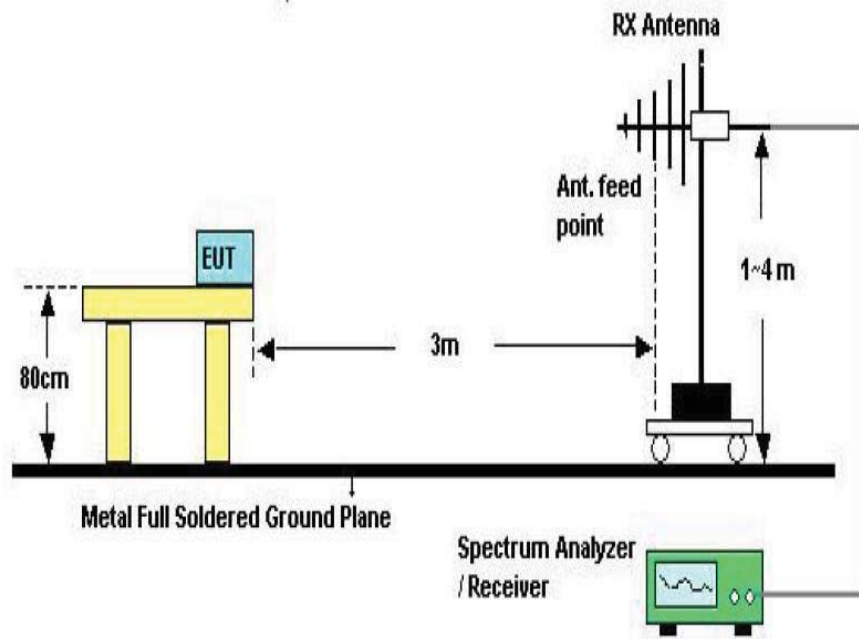

Above 30MHz Test Setup

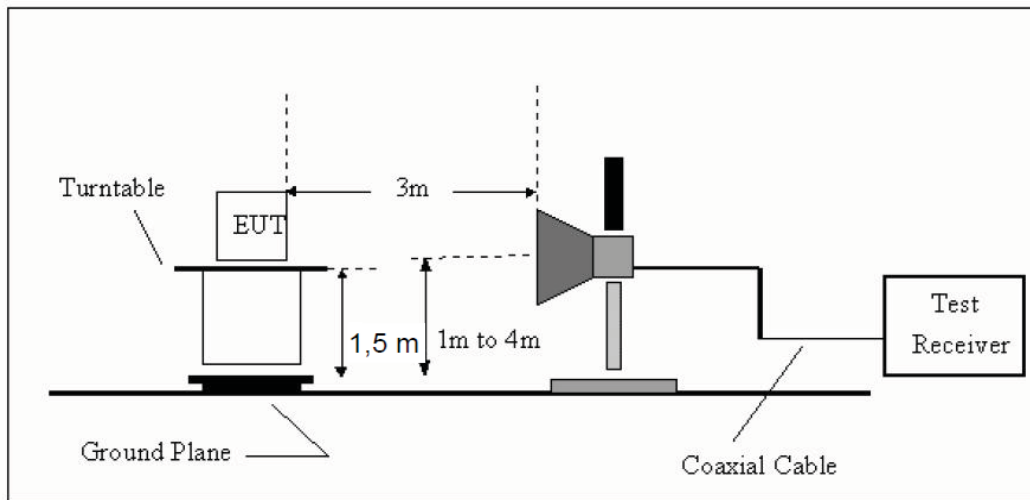

Above 1GHz Test Setup

5.1.3 Test Procedure

- The measuring distance of 3m shall be used for measurements at frequency up to 1GHz and above 1GHz, The EUT was placed on a rotating 0.8 m high above ground for below 1GHz and 1.5m high for above 1GHz testing, The table was rotated 360 degrees to determine the position of the highest radiation
- The Test antenna shall vary between 1m and 4m, Both Horizontal and Vertical antenna are set to make measurement.
- The initial step in collecting conducted emission data is a spectrum analyzer Peak detector mode pre-scanning the measurement frequency range. Significant Peaks are then marked. and then Quasi Peak Detector mode premeasured
- If Peak value comply with QP limit Below 1GHz. The EUT deemed to comply with QP limit. But the Peak value and average value both need to comply with applicable limit above 1GHz.
- For the actual test configuration, please see the test setup photo.

5.1.4 Test Equipment Setting For emission test Result

9KHz~150KHz	RBW 200Hz	VBW 1KHz
150KHz~30MHz	RBW 9KHz	VBW 30KHz
30MHz~1GHz	RBW 120KHz	VBW 300KHz
Above 1GHz	RBW 1MHz	VBW 3MHz

5.1.5 Test Condition

Continual Transmitting in maximum power.

5.1.6 Test Result

We have scanned the 9KHz from 25GHz to the EUT.
Detailed information please see the following page.

From 9KHz to 30MHz: Conclusion: PASS

Note: The amplitude of spurious emissions which are attenuated by more than 20dB below the permissible value has no need to be reported.

H:

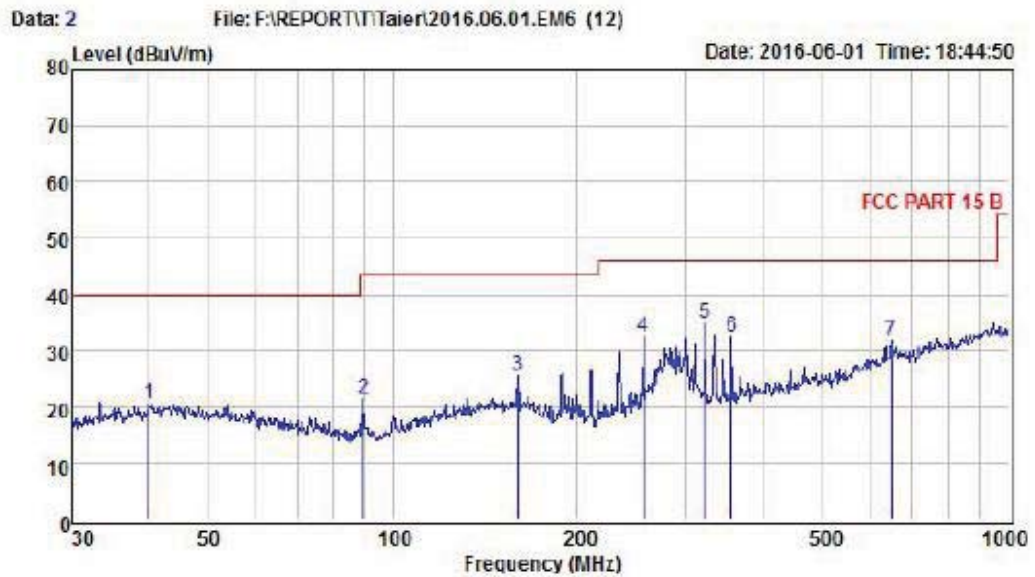

Condition : FCC PART 15 B POL: HORIZONTAL
 EUT :
 Model No :
 Test Mode :
 Power :
 Test Engineer :
 Remark :
 Temp :
 Hum :

Item	Freq MHz	Read Level dBuV	Antenna Factor dB	Preamp Factor dB	Cable Loss dB	Level dBuV	Limit dBuV	Margin dBuV	Remark
1	40.13	37.25	14.07	30.85	0.17	20.64	40.00	-19.36	Peak
2	89.59	41.85	9.44	30.23	0.33	21.39	43.50	-22.11	Peak
3	159.78	40.08	14.14	29.17	0.44	25.49	43.50	-18.01	Peak
4	255.62	48.30	11.69	28.21	0.56	32.34	46.00	-13.66	Peak
5	322.19	48.69	13.38	27.88	0.56	34.75	46.00	-11.25	Peak
6	355.43	45.77	13.91	27.75	0.63	32.56	46.00	-13.44	Peak
7	647.39	36.97	19.06	25.47	1.16	31.72	46.00	-14.28	Peak

Remark: Level - Read Level + Antenna Factor - Preamp Factor + Cable Loss

V:

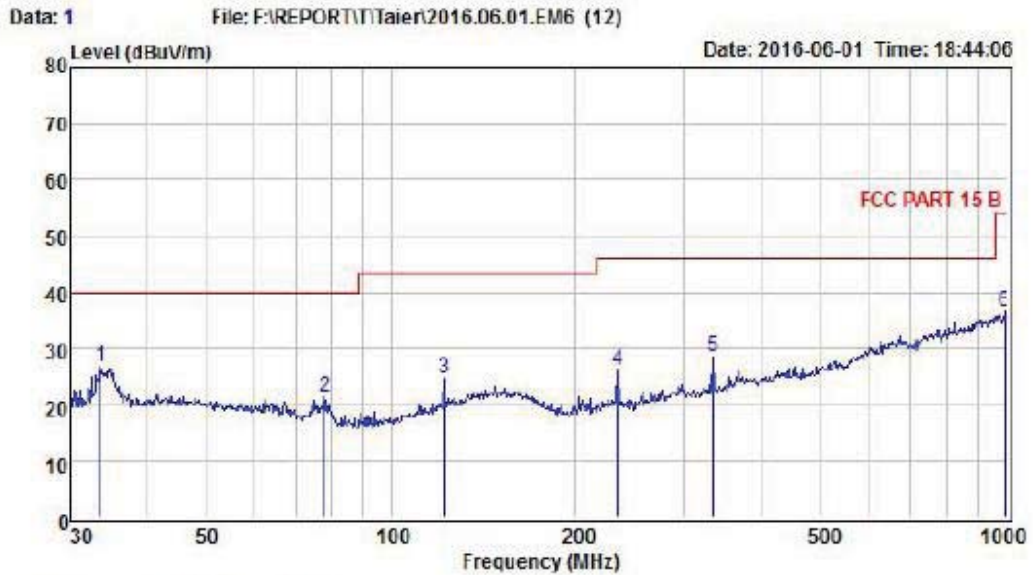

Condition : FCC PART 15 B POL: VERTICAL
 EUI :
 Model No :
 Test Mode :
 Power :
 Test Engineer :
 Remark :
 Temp :
 Hum :

Item	Freq MHz	Read Level dBuV	Antenna Factor dB	Preamp Factor dB	Cable Loss dB	Level dBuV	Limit dBuV	Margin dBuV	Remark
1	33.68	44.15	13.33	30.90	0.12	26.70	40.00	-13.30	Peak
2	77.87	41.62	9.60	30.01	0.29	21.50	40.00	-18.50	Peak
3	121.98	41.44	12.35	29.64	0.43	24.58	43.50	-18.92	Peak
4	233.35	42.39	11.31	28.10	0.49	26.09	46.00	-19.91	Peak
5	333.69	41.97	13.55	27.64	0.61	28.49	46.00	-17.51	Peak
6	993.01	37.96	22.22	25.24	1.59	36.53	54.00	-17.47	Peak

Remark: Level = Read Level + Antenna Factor - Preamp Factor + Cable Loss

From 1G-25GHz

EUT	UP BOX+	Model Name	3DP-25-4F
Temperature	26°C	Relative Humidity	56%
Pressure	960hPa	Test voltage	DC 24V from adapter
Test Mode	TX Low		

IEEE 802.11b

Freq. (MHz)	Ant. Pol H/V	Peak Reading (dBuV)	AV Reading (dBuV)	Ant. / CL CF (dB)	Actual Fs		Peak Limit (dBuV/m)	AV Limit (dBuV/m)	Margin (dB)	Remark
					Peak (dBuV/m)	AV (dBuV/m)				
1103	V	46.5	---	-11.24	35.26	---	74	54	38.74	Peak
4824	V	38.88	---	0.64	39.52	---	74	54	34.48	Peak
N/A										

EUT	UP BOX+	Model Name	3DP-25-4F
Temperature	26°C	Relative Humidity	56%
Pressure	960hPa	Test voltage	DC 24V from adapter
Test Mode	TX Low		

Freq. (MHz)	Ant. Pol H/V	Peak Reading (dBuV)	AV Reading (dBuV)	Ant. / CL CF (dB)	Actual Fs		Peak Limit (dBuV/m)	AV Limit (dBuV/m)	Margin (dB)	Remark
					Peak (dBuV/m)	AV (dBuV/m)				
1103	H	46.02	---	-11.24	34.78	---	74	54	39.22	Peak
4824	H	38.61	---	0.64	39.25	---	74	54	34.75	Peak
N/A										

Notes: AV Means AV detector test data, Peak Means Peak detector test data.

Emissions attenuated more than 20 dB below the permissible value are not reported.

EUT	UP BOX+	Model Name	3DP-25-4F
Temperature	26°C	Relative Humidity	56%
Pressure	960hPa	Test voltage	DC 24V from adapter
Test Mode	TX Mid		

Freq. (MHz)	Ant. Pol H/V	Peak Reading (dBuV)	AV Reading (dBuV)	Ant. / CL CF (dB)	Actual Fs		Peak Limit (dBuV/m)	AV Limit (dBuV/m)	Margin (dB)	Remark
					Peak (dBuV/m)	AV (dBuV/m)				
1103	V	45.47	---	-11.24	34.23	---	74	54	39.77	Peak
4874	V	41.21	---	0.76	41.97	---	74	54	32.03	Peak

EUT	UP BOX+	Model Name	3DP-25-4F
Temperature	26°C	Relative Humidity	56%
Pressure	960hPa	Test voltage	DC 24V from adapter
Test Mode	TX Mid		

Freq. (MHz)	Ant. Pol H/V	Peak Reading (dBuV)	AV Reading (dBuV)	Ant. / CL CF (dB)	Actual Fs		Peak Limit (dBuV/m)	AV Limit (dBuV/m)	Margin (dB)	Remark
					Peak (dBuV/m)	AV (dBuV/m)				
1103	H	45.63	---	-11.24	34.39	---	74	54	39.61	Peak
4874	H	42.21	---	0.76	42.97	---	74	54	31.03	Peak

Notes: AV Means AV detector test data, Peak Means Peak detector test data.

Emissions attenuated more than 20 dB below the permissible value are not reported.

EUT	UP BOX+	Model Name	3DP-25-4F
Temperature	26°C	Relative Humidity	56%
Pressure	960hPa	Test voltage	DC 24V from adapter
Test Mode	TX High		

Freq. (MHz)	Ant. Pol H/V	Peak Reading (dBuV)	AV Reading (dBuV)	Ant. / CL CF (dB)	Actual Fs		Peak Limit (dBuV/m)	AV Limit (dBuV/m)	Margin (dB)	Remark
					Peak (dBuV/m)	AV (dBuV/m)				
1103	V	45.42	---	-11.24	34.18	---	74	54	39.82	Peak
4924	V	36.84	---	0.87	37.71	---	74	54	36.29	Peak

EUT	UP BOX+	Model Name	3DP-25-4F
Temperature	26°C	Relative Humidity	56%
Pressure	960hPa	Test voltage	DC 24V from adapter
Test Mode	TX High		

Freq. (MHz)	Ant. Pol H/V	Peak Reading (dBuV)	AV Reading (dBuV)	Ant. / CL CF (dB)	Actual Fs		Peak Limit (dBuV/m)	AV Limit (dBuV/m)	Margin (dB)	Remark
					Peak (dBuV/m)	AV (dBuV/m)				
1103	H	45.83	---	-11.24	34.59	---	74	54	39.41	Peak
4924	H	35.68	---	0.87	36.55	---	74	54	37.45	Peak

Notes: AV Means AV detector test data, Peak Means Peak detector test data.

Emissions attenuated more than 20 dB below the permissible value are not reported.

IEEE 802.11 g:

EUT	UP BOX+	Model Name	3DP-25-4F
Temperature	26°C	Relative Humidity	56%
Pressure	960hPa	Test voltage	DC 24V from adapter
Test Mode	TX Low		

Freq. (MHz)	Ant. Pol H/V	Peak Reading (dBuV)	AV Reading (dBuV)	Ant. / CL CF (dB)	Actual Fs		Peak Limit (dBuV/m)	AV Limit (dBuV/m)	Margin (dB)	Remark
					Peak (dBuV/m)	AV (dBuV/m)				
1145	V	46.3	---	-11.24	35.06	---	74	54	38.94	Peak
2586	V	48.37	---	-7.13	41.24	---	74	54	32.76	Peak
3062	V	46.43	---	-5.74	40.69	---	74	54	33.31	Peak
4824	V	46.03	---	0.64	46.67	---	74	54	27.33	Peak
N/A										

EUT	UP BOX+	Model Name	3DP-25-4F
Temperature	26°C	Relative Humidity	56%
Pressure	960hPa	Test voltage	DC 24V from adapter
Test Mode	TX Low		

Freq. (MHz)	Ant. Pol H/V	Peak Reading (dBuV)	AV Reading (dBuV)	Ant. / CL CF (dB)	Actual Fs		Peak Limit (dBuV/m)	AV Limit (dBuV/m)	Margin (dB)	Remark
					Peak (dBuV/m)	AV (dBuV/m)				
1294	H	45.64	---	-10.96	34.68	---	74	54	39.32	Peak
2038	H	45.83	---	-8.58	37.25	---	74	54	36.75	Peak
3483	H	44.73	---	-4.95	39.78	---	74	54	34.22	Peak
4824	H	43.53	---	0.64	44.17	---	74	54	29.83	Peak
N/A										

Notes: AV Means AV detector test data, Peak Means Peak detector test data.

Emissions attenuated more than 20 dB below the permissible value are not reported.

EUT	UP BOX+	Model Name	3DP-25-4F
Temperature	26°C	Relative Humidity	56%
Pressure	960hPa	Test voltage	DC 24V from adapter
Test Mode	TX Mid		

Freq. (MHz)	Ant. Pol H/V	Peak Reading (dBuV)	AV Reading (dBuV)	Ant. / CL CF (dB)	Actual Fs		Peak Limit (dBuV/m)	AV Limit (dBuV/m)	Margin (dB)	Remark
					Peak (dBuV/m)	AV (dBuV/m)				
1374	V	43.12	---	-10.43	32.69	---	74	54	41.31	Peak
2589	V	43.71	---	-7.13	36.58	---	74	54	37.42	Peak
3365	V	43.09	---	-5.18	37.91	---	74	54	36.09	Peak
4874	V	42.31	---	0.76	43.07	---	74	54	30.93	Peak

EUT	UP BOX+	Model Name	3DP-25-4F
Temperature	26°C	Relative Humidity	56%
Pressure	960hPa	Test voltage	DC 24V from adapter
Test Mode	TX Mid		

Freq. (MHz)	Ant. Pol H/V	Peak Reading (dBuV)	AV Reading (dBuV)	Ant. / CL CF (dB)	Actual Fs		Peak Limit (dBuV/m)	AV Limit (dBuV/m)	Margin (dB)	Remark
					Peak (dBuV/m)	AV (dBuV/m)				
1321	H	45.83	---	-10.84	34.99	---	74	54	39.01	Peak
2314	H	46.53	---	-7.46	39.07	---	74	54	34.93	Peak
3577	H	44.82	---	-4.76	40.06	---	74	54	33.94	Peak
4874	H	42.53	---	0.76	43.29	---	74	54	30.71	Peak

Notes: AV Means AV detector test data, Peak Means Peak detector test data.

Emissions attenuated more than 20 dB below the permissible value are not reported.

EUT	UP BOX+	Model Name	3DP-25-4F
Temperature	26°C	Relative Humidity	56%
Pressure	960hPa	Test voltage	DC 24V from adapter
Test Mode	TX High		

Freq. (MHz)	Ant. Pol H/V	Peak Reading (dBuV)	AV Reading (dBuV)	Ant. / CL CF (dB)	Actual Fs		Peak Limit (dBuV/m)	AV Limit (dBuV/m)	Margin (dB)	Remark
					Peak (dBuV/m)	AV (dBuV/m)				
1302	V	45.83	---	-10.84	34.99	---	74	54	39.01	Peak
2982	V	46.37	---	-5.86	40.51	---	74	54	33.49	Peak
3831	V	45.43	---	-3.96	41.47	---	74	54	32.53	Peak
4924	V	43.83	---	0.87	44.7	---	74	54	29.3	Peak

EUT	UP BOX+	Model Name	3DP-25-4F
Temperature	26°C	Relative Humidity	56%
Pressure	960hPa	Test voltage	DC 24V from adapter
Test Mode	TX High		

Freq. (MHz)	Ant. Pol H/V	Peak Reading (dBuV)	AV Reading (dBuV)	Ant. / CL CF (dB)	Actual Fs		Peak Limit (dBuV/m)	AV Limit (dBuV/m)	Margin (dB)	Remark
					Peak (dBuV/m)	AV (dBuV/m)				
1446	H	46.01	---	-10.29	35.72	---	74	54	38.28	Peak
2198	H	44.83	---	-8.24	36.59	---	74	54	37.41	Peak
3905	H	45.93	---	-3.68	42.25	---	74	54	31.75	Peak
4924	H	43.41	---	0.87	44.28	---	74	54	29.72	Peak

Notes: AV Means AV detector test data, Peak Means Peak detector test data.

Emissions attenuated more than 20 dB below the permissible value are not reported.

IEEE 802.11n/HT20 with 2.4G

EUT	UP BOX+	Model Name	3DP-25-4F
Temperature	26°C	Relative Humidity	56%
Pressure	960hPa	Test voltage	DC 24V from adapter
Test Mode	TX Low		

Freq. (MHz)	Ant. Pol H/V	Peak Reading (dBuV)	AV Reading (dBuV)	Ant. / CL CF (dB)	Actual Fs		Peak Limit (dBuV/m)	AV Limit (dBuV/m)	Margin (dB)	Remark
					Peak (dBuV/m)	AV (dBuV/m)				
1492	V	46.01	---	-10.27	35.74	---	74	54	38.26	Peak
2671	V	45.6	---	-6.94	38.66	---	74	54	35.34	Peak
3948	V	45.79	---	-3.68	42.11	---	74	54	31.89	Peak
4824	V	44.54	---	0.64	45.18	---	74	54	28.82	Peak
N/A										

EUT	UP BOX+	Model Name	3DP-25-4F
Temperature	26°C	Relative Humidity	56%
Pressure	960hPa	Test voltage	DC 24V from adapter
Test Mode	TX Low		

Freq. (MHz)	Ant. Pol H/V	Peak Reading (dBuV)	AV Reading (dBuV)	Ant. / CL CF (dB)	Actual Fs		Peak Limit (dBuV/m)	AV Limit (dBuV/m)	Margin (dB)	Remark
					Peak (dBuV/m)	AV (dBuV/m)				
1451	H	46.04	---	-10.27	35.77	---	74	54	38.23	Peak
2839	H	46.31	---	-6.17	40.14	---	74	54	33.86	Peak
3607	H	45.88	---	-4.52	41.36	---	74	54	32.64	Peak
4824	H	44.8	---	0.64	45.44	---	74	54	28.56	Peak
N/A										

Notes: AV Means AV detector test data, Peak Means Peak detector test data.

Emissions attenuated more than 20 dB below the permissible value are not reported.

EUT	UP BOX+	Model Name	3DP-25-4F
Temperature	26°C	Relative Humidity	56%
Pressure	960hPa	Test voltage	DC 24V from adapter
Test Mode	TX Mid		

Freq. (MHz)	Ant. Pol H/V	Peak Reading (dBuV)	AV Reading (dBuV)	Ant. / CL CF (dB)	Actual Fs		Peak Limit (dBuV/m)	AV Limit (dBuV/m)	Margin (dB)	Remark
					Peak (dBuV/m)	AV (dBuV/m)				
1262	V	45.73	---	-10.96	34.77	---	74	54	39.23	Peak
2013	V	46.17	---	-8.58	37.59	---	74	54	36.41	Peak
3798	V	45.41	---	-4.07	41.34	---	74	54	32.66	Peak
4874	V	44.53	---	0.76	45.29	---	74	54	28.71	Peak

EUT	UP BOX+	Model Name	3DP-25-4F
Temperature	26°C	Relative Humidity	56%
Pressure	960hPa	Test voltage	DC 24V from adapter
Test Mode	TX Mid		

Freq. (MHz)	Ant. Pol H/V	Peak Reading (dBuV)	AV Reading (dBuV)	Ant. / CL CF (dB)	Actual Fs		Peak Limit (dBuV/m)	AV Limit (dBuV/m)	Margin (dB)	Remark
					Peak (dBuV/m)	AV (dBuV/m)				
1511	H	45.63	---	-10.14	35.49	---	74	54	38.51	Peak
2353	H	45.79	---	-7.59	38.2	---	74	54	35.8	Peak
3266	H	46.06	---	-5.39	40.67	---	74	54	33.33	Peak
4874	H	44.8	---	0.76	45.56	---	74	54	28.44	Peak

Notes: AV Means AV detector test data, Peak Means Peak detector test data.

Emissions attenuated more than 20 dB below the permissible value are not reported.

EUT	UP BOX+	Model Name	3DP-25-4F
Temperature	26°C	Relative Humidity	56%
Pressure	960hPa	Test voltage	DC 24V from adapter
Test Mode	TX High		

Freq. (MHz)	Ant. Pol H/V	Peak Reading (dBuV)	AV Reading (dBuV)	Ant. / CL CF (dB)	Actual Fs		Peak Limit (dBuV/m)	AV Limit (dBuV/m)	Margin (dB)	Remark
					Peak (dBuV/m)	AV (dBuV/m)				
1477	V	47.06	---	-10.27	36.79	---	74	54	37.21	Peak
2703	V	45.94	---	-6.43	39.51	---	74	54	34.49	Peak
3561	V	45.83	---	-4.76	41.07	---	74	54	32.93	Peak
4924	V	44.66	---	0.87	45.53	---	74	54	28.47	Peak

EUT	UP BOX+	Model Name	3DP-25-4F
Temperature	26°C	Relative Humidity	56%
Pressure	960hPa	Test voltage	DC 24V from adapter
Test Mode	TX High		

Freq. (MHz)	Ant. Pol H/V	Peak Reading (dBuV)	AV Reading (dBuV)	Ant. / CL CF (dB)	Actual Fs		Peak Limit (dBuV/m)	AV Limit (dBuV/m)	Margin (dB)	Remark
					Peak (dBuV/m)	AV (dBuV/m)				
1503	H	45.61	---	-10.14	35.47	---	74	54	38.53	Peak
3588	H	45.91	---	-4.96	40.95	---	74	54	33.05	Peak
4153	H	45.72	---	-2.48	43.24	---	74	54	30.76	Peak
4924	H	43.77	---	0.87	44.64	---	74	54	29.36	Peak

Notes: AV Means AV detector test data, Peak Means Peak detector test data.

Emissions attenuated more than 20 dB below the permissible value are not reported.

6 POWER LINE CONDUCTED EMISSION

6.1 Conducted Emission Limits(15.207)

Frequency MHz	Limits dB(μ V)	
	Quasi-peak Level	Average Level
0.15 -0.50	66 -56*	56 - 46*
0.50 -5.00	56	46
5.00 -30.00	60	50

Notes: 1. *Decreasing linearly with logarithm of frequency.

2. The lower limit shall apply at the transition frequencies.

3. The limit decreases in line with the logarithm of the frequency in the rang of 0.15 to 0.50 MHz.

6.2 Test Setup

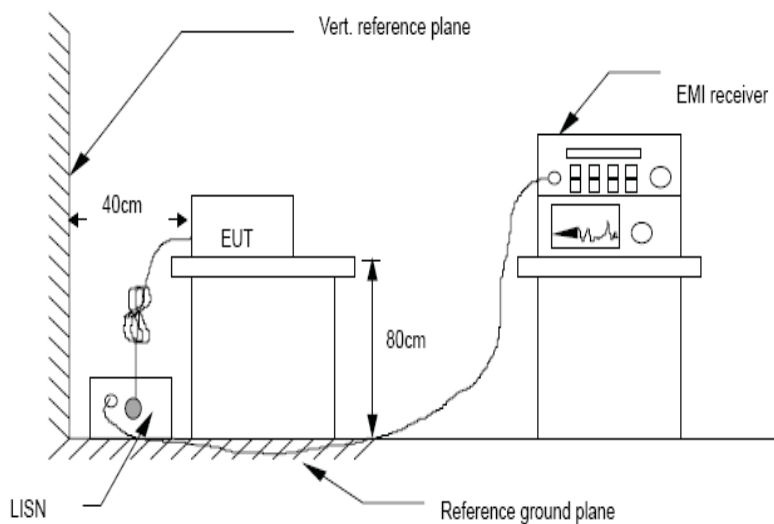

6.3 Test Procedure

The EUT is put on the plane 0.8m high above the ground by insulating support and is connected to the power mains through a line impedance stabilization network (L.I.S.N.). This provides a 50ohm coupling impedance for the EUT system. Please refer the block diagram of the test setup and photographs. Both sides of AC lines are checked to find out the maximum conducted emission. In order to find the maximum emission levels, the relative positions of equipment and all of the interface cables shall be changed according to ANSI C63.10:2013 on Conducted Emission Measurement. The bandwidth of test receiver (R & S ESCI) is set at 9 kHz.

6.4 Test Results

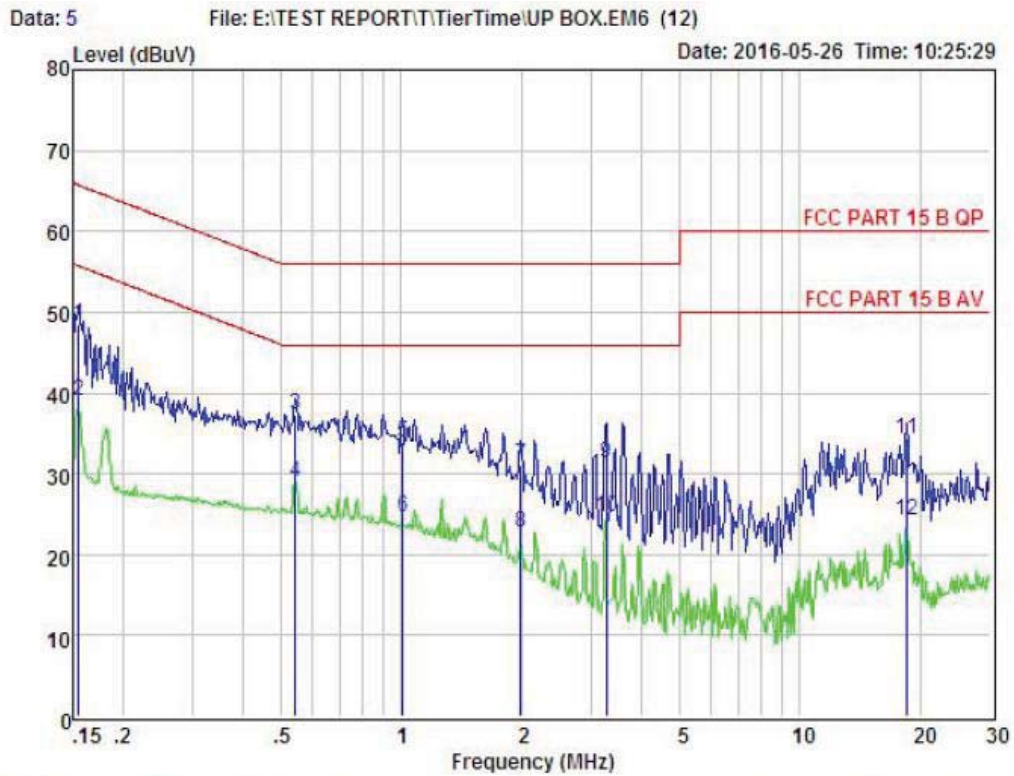

Condition : FCC PART 15 B QP POL: LINE Temp: 20.1 °C Hum: 45 %
 EUT : UP BOX +
 Model No :
 Test Mode :
 Power : DC 19V From Adapter With AC 120V/60Hz
 Test Engineer :
 Remark :

Item	Freq MHz	Read Level dBuV	LISN Factor dB	Preamp Factor dB	Cable Loss dB	Level dBuV	Limit dBuV	Margin dBuV	Remark
1	0.155	38.72	0.03	-9.72	0.10	48.57	65.74	-17.17	QP
2	0.155	29.20	0.03	-9.72	0.10	39.05	55.74	-16.69	Average
3	0.541	27.38	0.03	-9.72	0.10	37.23	56.00	-18.77	QP
4	0.541	19.16	0.03	-9.72	0.10	29.01	46.00	-16.99	Average
5	1.010	23.94	0.04	-9.71	0.10	33.79	56.00	-22.21	QP
6	1.010	14.91	0.04	-9.71	0.10	24.76	46.00	-21.24	Average
7	1.991	21.20	0.06	-9.70	0.10	31.06	56.00	-24.94	QP
8	1.991	12.80	0.06	-9.70	0.10	22.66	46.00	-23.34	Average
9	3.276	21.47	0.07	-9.69	0.12	31.35	56.00	-24.65	QP
10	3.276	14.89	0.07	-9.69	0.12	24.77	46.00	-21.23	Average
11	18.622	24.17	0.30	-9.46	0.33	34.26	60.00	-25.74	QP
12	18.622	14.08	0.30	-9.46	0.33	24.17	50.00	-25.83	Average

Remark: Level = Read Level + LISN Factor - Preamp Factor + Cable Loss

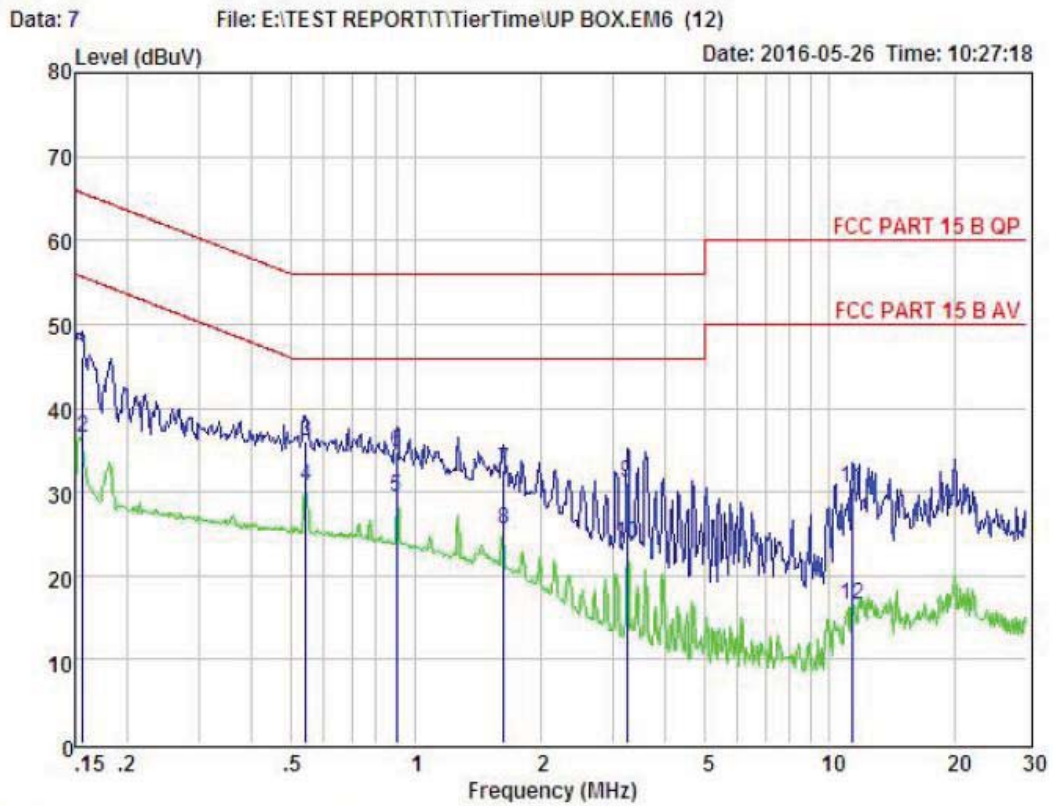

Condition : FCC PART 15 B QP POL: NEUTRAL Temp: 20.1 °C Hum: 45 %
 EUT : UP BOX +
 Model No :
 Test Mode :
 Power : DC 19V From Adapter With AC 120V/60Hz
 Test Engineer : Eric
 Remark :

Item	Freq MHz	Read Level dBUV	LISN Factor dB	Preamp Factor dB	Cable Loss dB	Level dBUV	Limit dBUV	Margin dBUV	Remark
1	0.156	36.31	0.03	-9.72	0.10	46.16	65.65	-19.49	QP
2	0.156	26.69	0.03	-9.72	0.10	36.54	55.65	-19.11	Average
3	0.541	26.26	0.03	-9.72	0.10	36.11	56.00	-19.89	QP
4	0.541	20.89	0.03	-9.72	0.10	30.74	46.00	-15.26	Average
5	0.899	19.53	0.04	-9.71	0.10	29.38	46.00	-16.62	Average
6	0.899	24.91	0.04	-9.71	0.10	34.76	56.00	-21.24	QP
7	1.628	22.72	0.05	-9.71	0.10	32.58	56.00	-23.42	QP
8	1.628	15.63	0.05	-9.71	0.10	25.49	46.00	-20.51	Average
9	3.241	21.26	0.07	-9.69	0.12	31.14	56.00	-24.86	QP
10	3.241	13.86	0.07	-9.69	0.12	23.74	46.00	-22.26	Average
11	11.317	20.45	0.24	-9.48	0.22	30.39	60.00	-29.61	QP
12	11.317	6.66	0.24	-9.48	0.22	16.60	50.00	-33.40	Average

Remark: Level = Read Level + LISN Factor - Preamp Factor + Cable Loss

7 Conducted Maximum Output Power

7.1 Test limit

Please refer section RSS-247 & 15.247.

7.2 Test Procedure

Details see the KDB558074 Meas Guidance V03

7.2.1 Place the EUT on the table and set it in transmitting mode.

7.2.2 Measure out each mode and each bands peak output power of EUT.

Note: The cable loss and attenuator loss were offset into measure device as amplitude offset.

Details see the KDB558074 DTS Meas Guidance V03

7.3 Test Setup

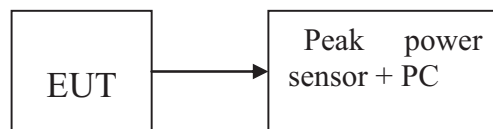

7.4 Test Results

PASS

Detailed information please see the following page.

EUT: UP BOX+		M/N: 3DP-25-4F		
Test date: 2016-05-28		Test site: RF site		Tested by: Eric Huang
Mode	Frequency (MHz)	PK Output power(dBm)	Limit (dBm)	Margin (dB)
IEEE 802.11 b	CH1: 2412	17.28	30	12.72
	CH6: 2437	17.35	30	12.65
	CH11: 2462	17.13	30	12.87
IEEE 802.11 g	CH1: 2412	16.16	30	13.84
	CH6: 2437	16.35	30	13.65
	CH11: 2462	16.03	30	13.97
IEEE 802.11 n/HT20 with 2.4G	CH1: 2412	16.21	30	13.79
	CH6: 2437	16.17	30	13.83
	CH11: 2462	16.22	30	13.78
Conclusion: PASS				

8 PEAK POWER SPECTRAL DENSITY

8.1 Test limit

8.1.1 Please refer section RSS-247 & 15.247.

8.1.2 For direct sequence systems, the peak power spectral density conducted from the intentional radiator to the antenna shall not be greater than 8dBm in any 3kHz band during any time interval of continuous transmission.

8.1.3 The direct sequence operating of the hybrid system, with the frequency hopping operation turned off, shall comply with the power density requirements of paragraph (d) of this section.

8.2 Method of measurement

Details see the KDB558074 DTS Meas Guidance V03

8.2.1 Place the EUT on the table and set it in transmitting mode.

8.2.2 Remove the antenna from the EUT and then connect a low loss RF cable from the antenna port to the spectrum analyzer.

8.2.3 Set the spectrum analyzer as RBW = 3kHz, VBW = 10kHz, span=5-30%EBW, detail see the test plot.

8.2.4 Record the max reading.

8.2.5 Repeat the above procedure until the measurements for all frequencies are completed.

8.3 Test Setup



8.4 Test Results

PASS.

Detailed information please see the following page.

EUT: UP BOX+		M/N: 3DP-25-4F		
Test date: 2016-05-28		Test site: RF site		Tested by: Eric Huang
Mode	Frequency (MHz)	PK Output power(dBm)	Limit (dBm)	Result
IEEE 802.11 b	CH1: 2412	-7.324	8	PASS
	CH6: 2437	-6.948	8	PASS
	CH11: 2462	-7.684	8	PASS
IEEE 802.11 g	CH1: 2412	-11.716	8	PASS
	CH6: 2437	-11.238	8	PASS
	CH11: 2462	-11.221	8	PASS
IEEE 802.11 n/HT20 with 2.4G	CH1: 2412	-11.223	8	PASS
	CH6: 2437	-10.389	8	PASS
	CH11: 2462	-11.700	8	PASS
Conclusion: PASS				

IEEE 802.11b :

CH Low :



CH Mid:



CH Hig:



IEEE 802.11g :
CH Low

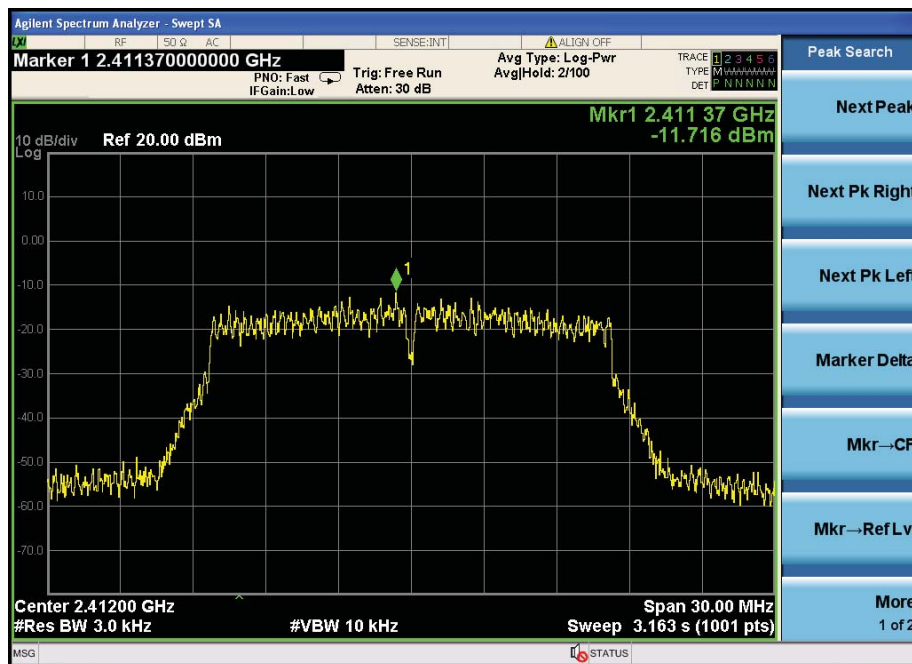

CH Mid:

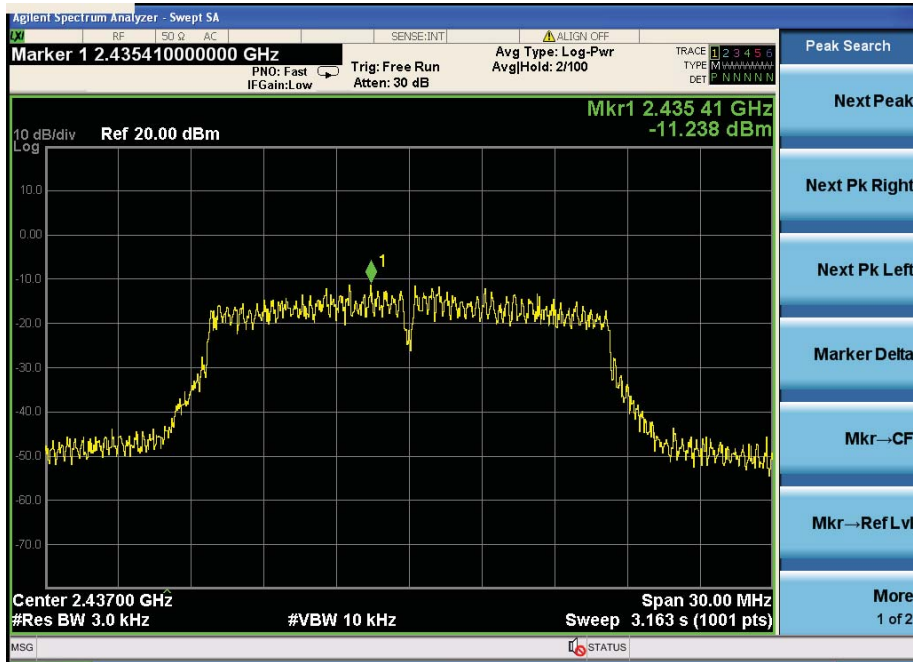

CH Hig:

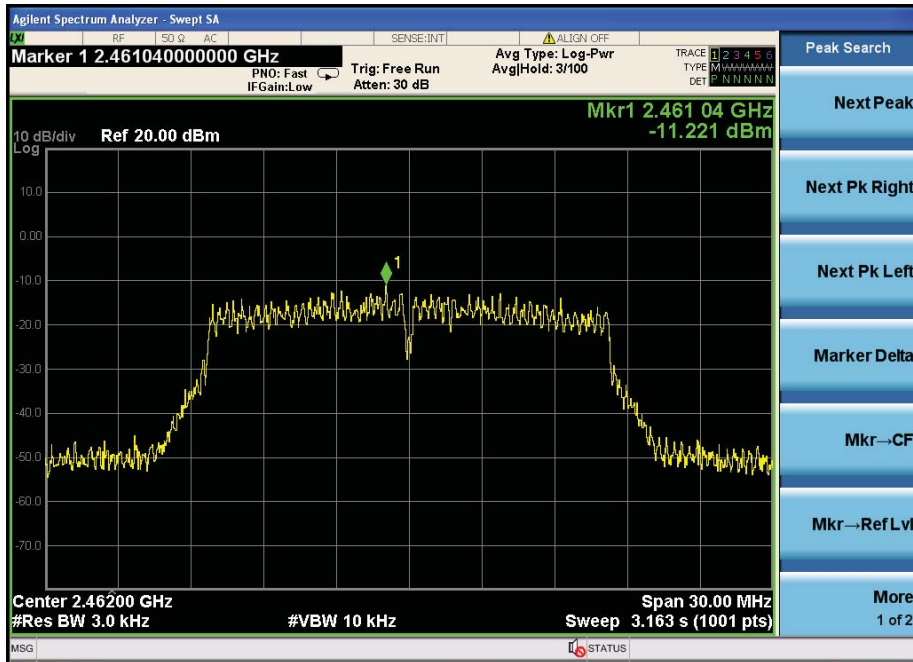

IEEE 802.11n HT20 :

CH Low :

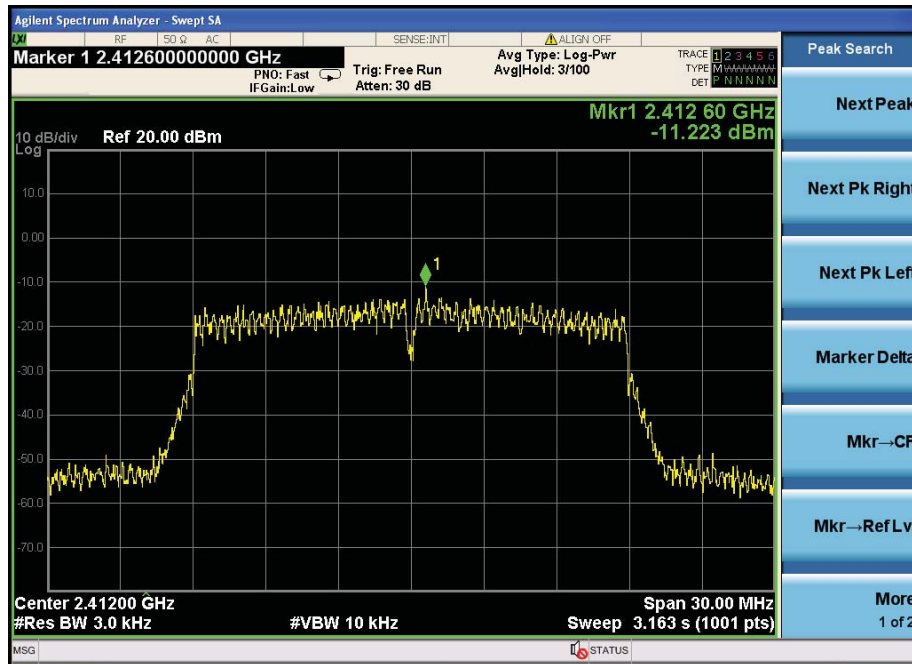

CH Mid:

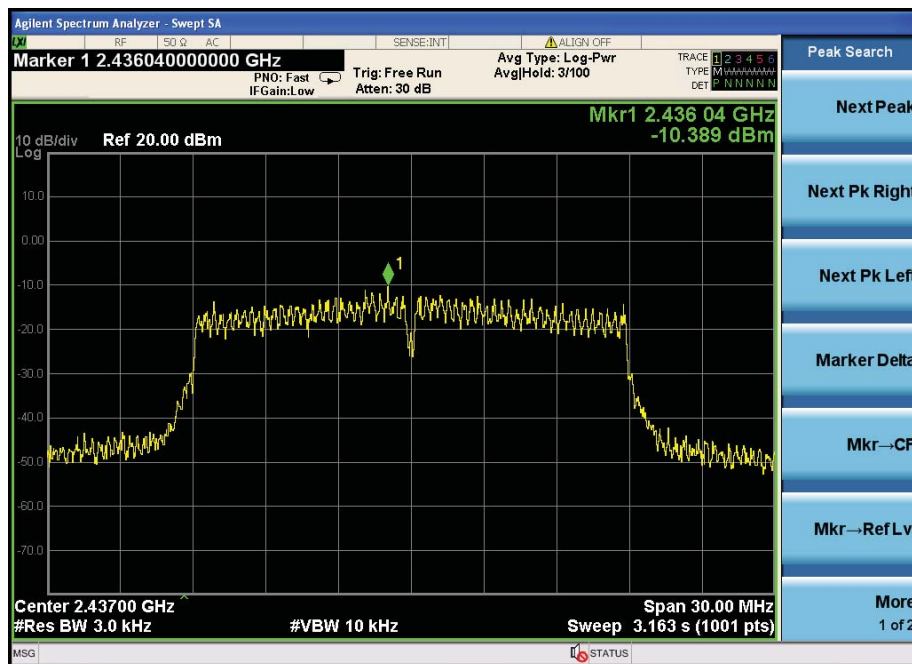

CH Hig:

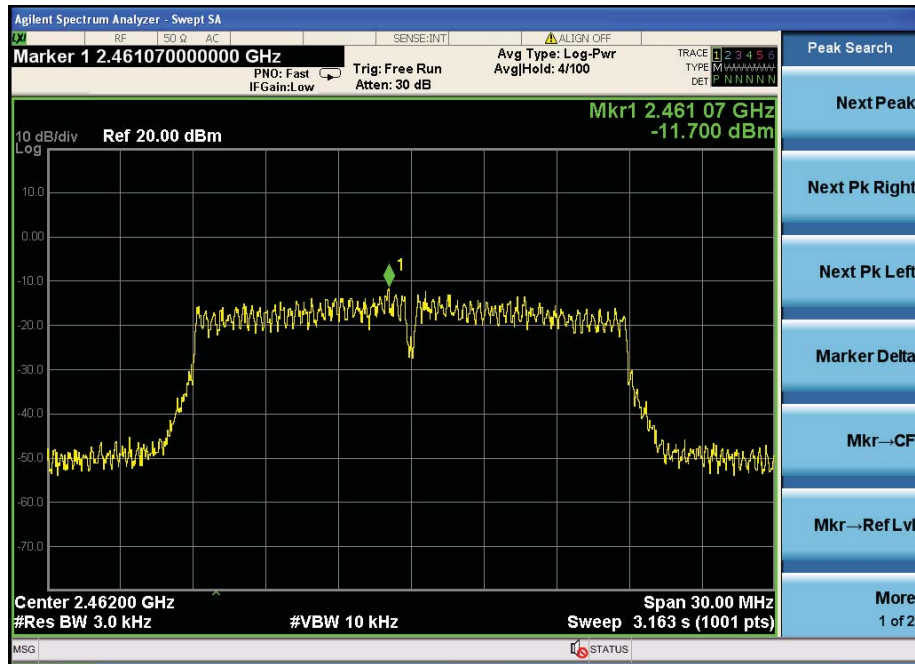

9 Bandwidth

9.1 Test limit

Please refer section RSS-247 & 15.247

For direct sequence systems, the minimum 6dB bandwidth shall be at least 500 kHz.

9.2 Method of measurement

Details see the KDB558074 D01 Meas Guidance

- a) Measure the maximum width of the emission that is constrained by the frequencies associated with the two outermost amplitude points (upper and lower frequencies) that are attenuated by 6 dB relative to the maximum level measured in the fundamental emission.
- b) The test receiver set RBW = 100KHz, VBW \geq 3RBW, Peak detector, Sweep time set auto, detail see the test plot.

9.3 Test Setup



9.4 Test Results

PASS.

Detailed information please see the following page.

Channel	Frequency (MHz)	6dB Bandwidth (MHz)	99% Occupied Bandwidth (MHz)	Limit (MHz)	Result
IEEE 802.11b:					
Low	2412	10.08	/	0.5	PASS
Mid	2437	9.606	/	0.5	PASS
High	2462	9.144	/	0.5	PASS
IEEE 802.11g					
Low	2412	15.14	/	0.5	PASS
Mid	2437	15.66	/	0.5	PASS
High	2462	15.47	/	0.5	PASS
IEEE 802.11n/HT20:					
Low	2412	15.05	/	0.5	PASS
Mid	2437	15.16	/	0.5	PASS
High	2462	16.90	/	0.5	PASS

IEEE 802.11b:

CH Low :

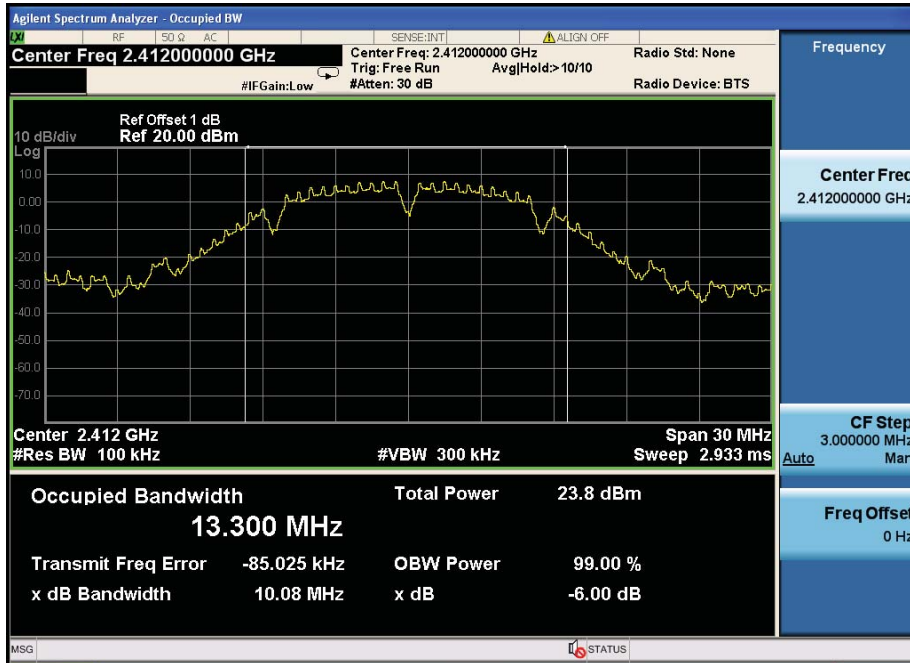

CH Mid :

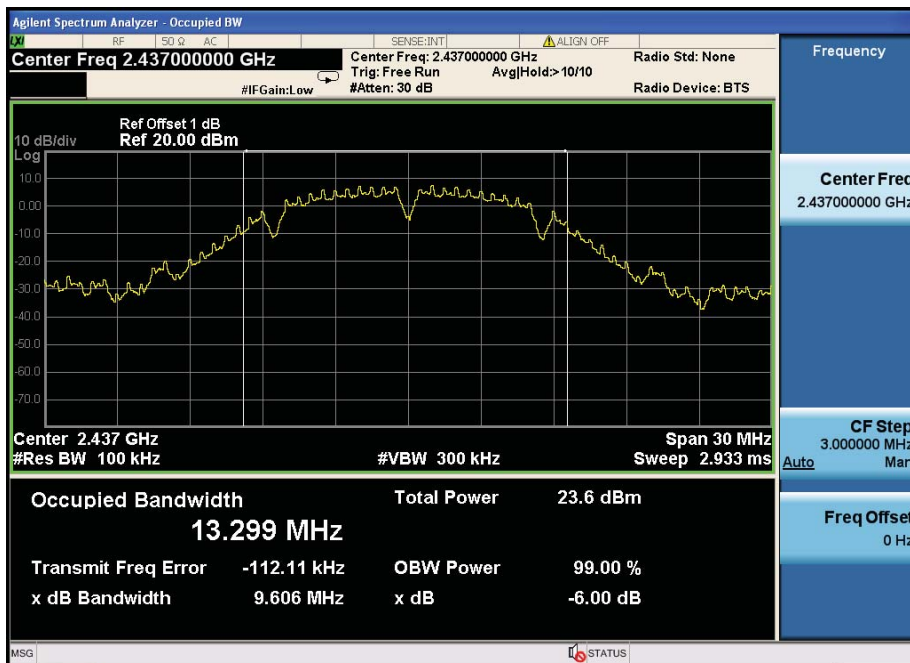

CH High :

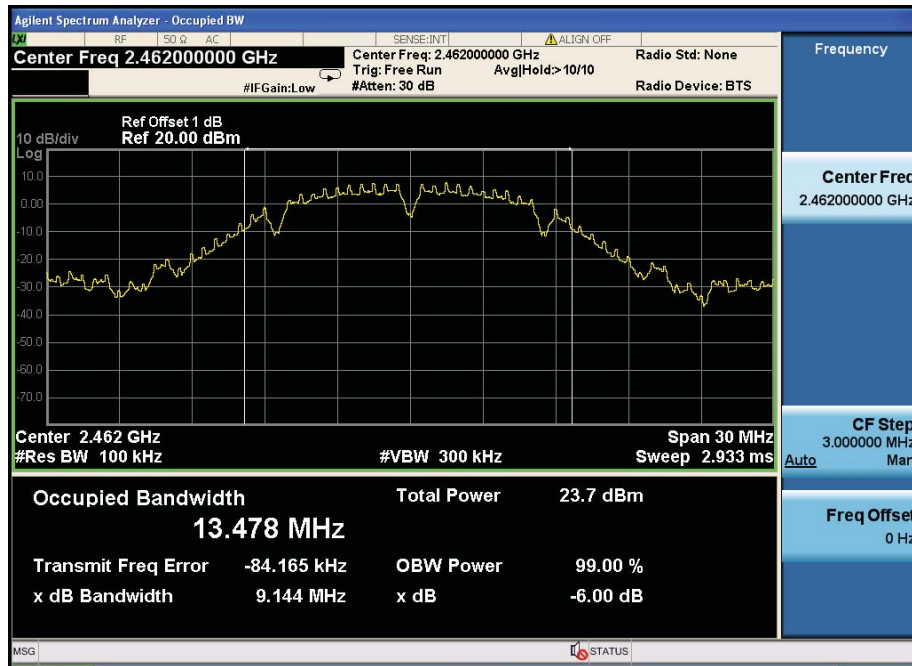

IEEE 802.11g:

CH Low :

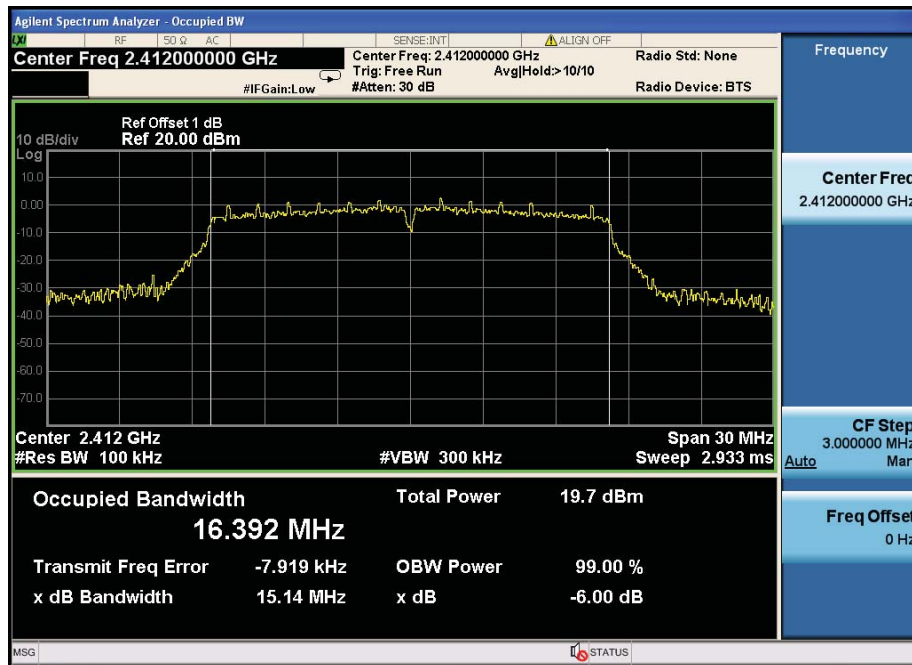

CH Mid:

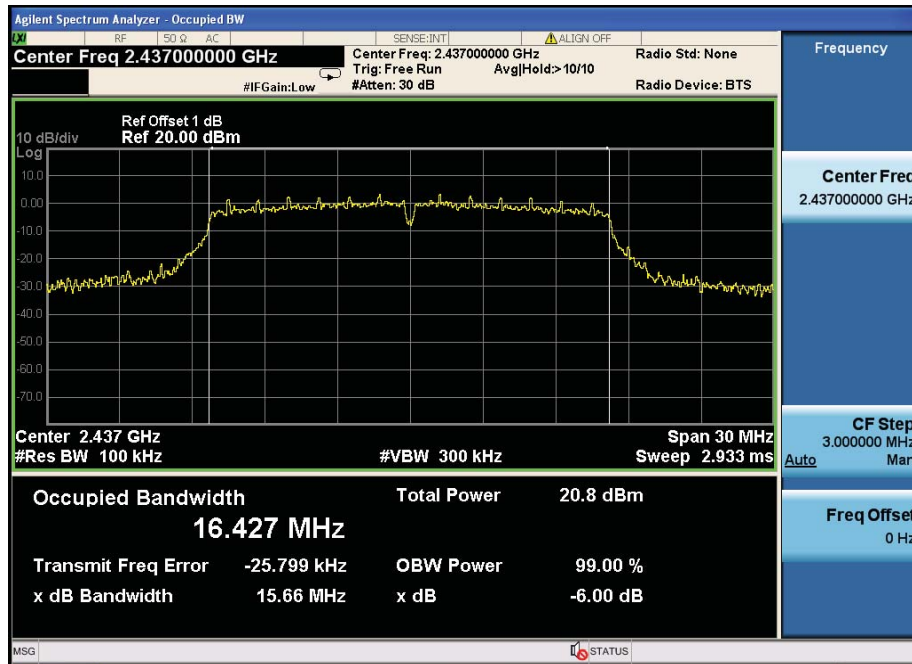

CH Hig:

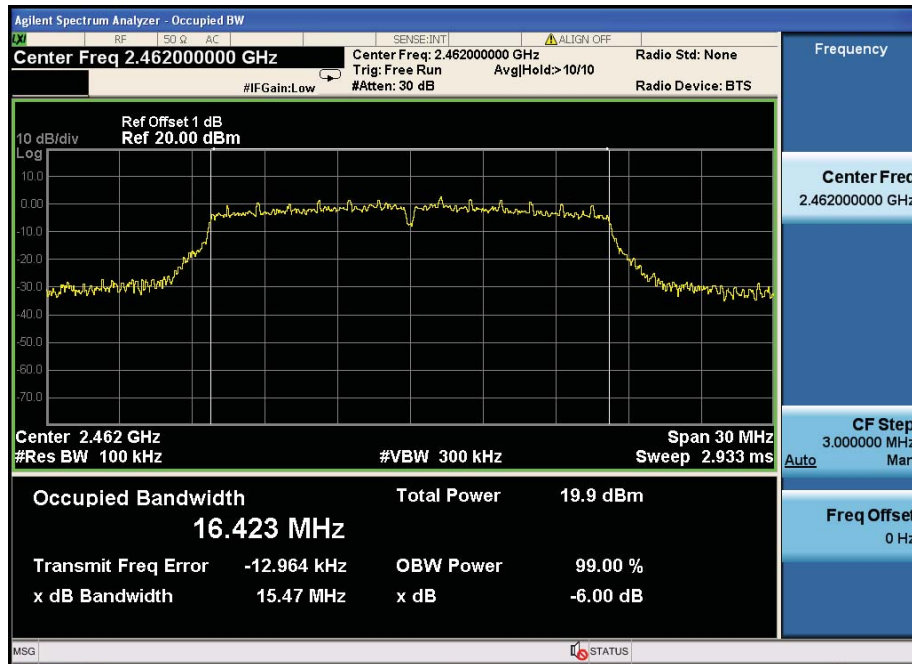

IEEE 802.11n HT20:

CH Low :

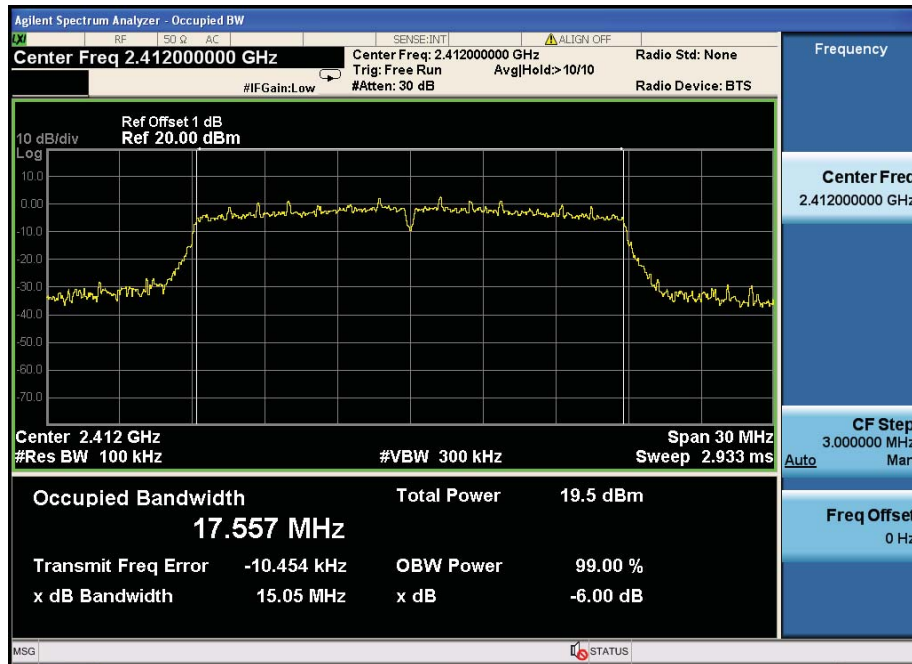

CH Mid :

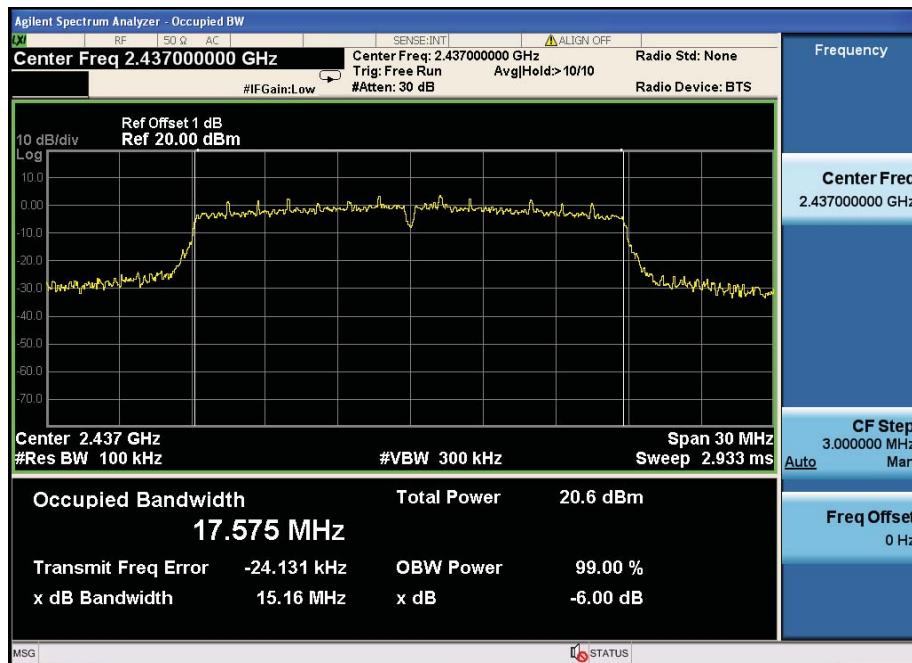

CH High :

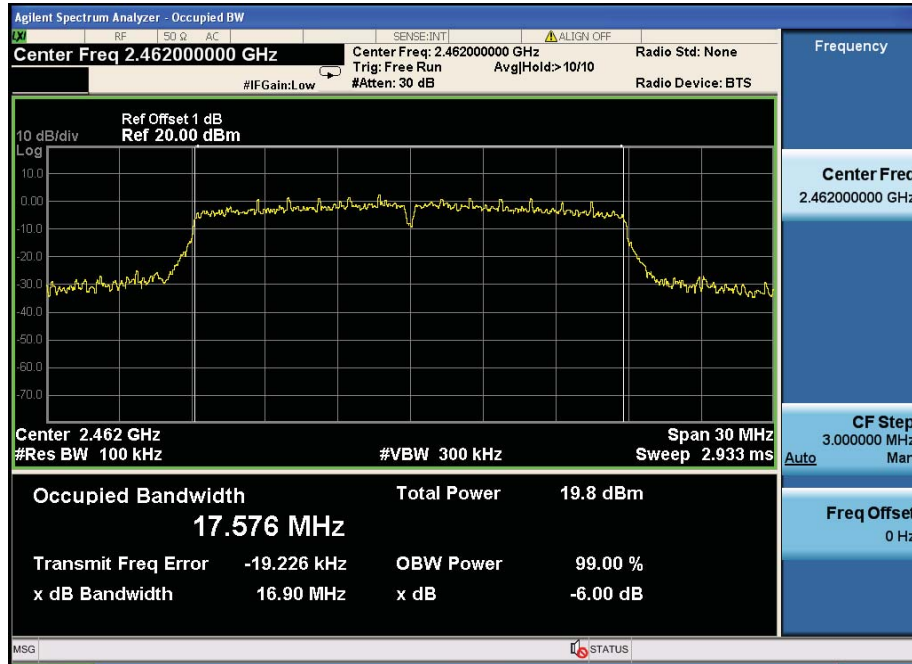

10 Band Edge Check

10.1 Test limit

Please refer section RSS-GEN&15.247.

10.2 Test Procedure

12.2.1 Put the EUT on a 0.8m high table, power on the EUT. Emissions were scanned and measured rotating the EUT to 360 degrees, Find the maximum Emission

12.2.2 Check the spurious emissions out of band.

12.2.3 RBW 1MHz ,VBW 3MHz ,peak detector for peak value , RBW 1MHz ,VBW 3MHz ,RMS detector for AV value.

10.3 Test Setup

Same as 5.2.2.

10.4 Test Result

PASS.

Detailed information please see the following page.

Radiated Method:
802.11b

Band Edge Test result								
EUT: UP BOX+			M/N: 3DP-25-4F					
Power: DC 24V from adapter								
Test date: 2016-05-28			Test site: 3m Chamber			Tested by: Eric Huang		
Test mode: Tx Low								
Antenna polarity: Vertical								
Freq (MHz)	Read Level (dBuV/m)	Antenna Factor (dB/m)	Cable loss(dB)	Amp Factor (dB)	Result (dBuV/m)	Limit (dBuV/m)	Margin (dB)	Remark
2390	45.03	27.62	3.92	34.97	41.6	74	32.4	PK
2390	--	27.62	3.92	34.97	--	54	--	AV
Antenna Polarity: Horizontal								
2390	44.52	27.62	3.92	34.97	41.09	74	32.91	PK
2390	--	27.62	3.92	34.97	--	54	--	AV
Note:								
1, Spectrum Set for PK measure: RBW=1MHz, VBW=1MHz, Sweep time=Auto, Detector: PK								
2, Spectrum Set for AV measure: RBW=1MHz, VBW=3MHz, Sweep time=Auto, Detector: RMS								
3, Result = Read level + Antenna factor + cable loss-Amp factor								
4, All the other emissions not reported were too low to read and deemed to comply with FCC limit.								

Band Edge Test result								
EUT: UP BOX+			M/N: 3DP-25-4F					
Power: DC 24V from adapter								
Test date: 2016-05-28			Test site: 3m Chamber			Tested by: Eric Huang		
Test mode: Tx High								
Antenna polarity: Vertical								
Freq (MHz)	Read Level (dBuV/m)	Antenna Factor (dB/m)	Cable loss(dB)	Amp Factor (dB)	Result (dBuV/m)	Limit (dBuV/m)	Margin (dB)	Remark
2483.5	44.36	27.89	4	34.97	41.28	74	32.72	PK
2483.5	--	27.89	4	34.97	--	54	--	AV
Antenna Polarity: Horizontal								
2483.5	44.55	27.89	4	34.97	41.47	74	32.53	PK
2483.5	--	27.89	4	34.97	--	54	--	AV
Note:								
1, Spectrum Set for PK measure: RBW=1MHz, VBW=1MHz, Sweep time=Auto, Detector: PK								
2, Spectrum Set for AV measure: RBW=1MHz, VBW=3MHz, Sweep time=Auto, Detector: RMS								
3, Result = Read level + Antenna factor + cable loss-Amp factor								
4, All the other emissions not reported were too low to read and deemed to comply with FCC limit.								

802.11g

Band Edge Test result								
EUT: UP BOX+			M/N: 3DP-25-4F					
Power: DC 24V from adapter								
Test date: 2016-05-28			Test site: 3m Chamber			Tested by: Eric Huang		
Test mode: Tx Low								
Antenna polarity: Vertical								
Freq (MHz)	Read Level (dBuV/m)	Antenna Factor (dB/m)	Cable loss(dB)	Amp Factor (dB)	Result (dBuV/m)	Limit (dBuV/m)	Margin (dB)	Remark
2390	43.36	27.62	3.92	34.97	39.93	74	34.07	PK
2390	--	27.62	3.92	34.97	--	54	--	AV
Antenna Polarity: Horizontal								
2390	44.31	27.62	3.92	34.97	40.88	74	33.12	PK
2390	--	27.62	3.92	34.97	--	54	--	AV
Note:								
1, Spectrum Set for PK measure: RBW=1MHz, VBW=1MHz, Sweep time=Auto, Detector: PK								
2, Spectrum Set for AV measure: RBW=1MHz, VBW=3MHz, Sweep time=Auto, Detector: RMS								
3, Result = Read level + Antenna factor + cable loss-Amp factor								
4, All the other emissions not reported were too low to read and deemed to comply with FCC limit.								

Band Edge Test result								
EUT: UP BOX+			M/N: 3DP-25-4F					
Power: DC 24V from adapter								
Test date: 2016-05-28			Test site: 3m Chamber			Tested by: Eric Huang		
Test mode: Tx High								
Antenna polarity: Vertical								
Freq (MHz)	Read Level (dBuV/m)	Antenna Factor (dB/m)	Cable loss(dB)	Amp Factor (dB)	Result (dBuV/m)	Limit (dBuV/m)	Margin (dB)	Remark
2483.5	43.83	27.89	4	34.97	40.75	74	33.25	PK
2483.5	--	--	--	--	--	54	--	AV
Antenna Polarity: Horizontal								
2483.5	44.05	27.89	4	34.97	40.97	74	33.03	PK
2483.5		--	--	--	--	54	--	AV
Note:								
1, Spectrum Set for PK measure: RBW=1MHz, VBW=1MHz, Sweep time=Auto, Detector: PK								
2, Spectrum Set for AV measure: RBW=1MHz, VBW=3MHz, Sweep time=Auto, Detector: RMS								
3, Result = Read level + Antenna factor + cable loss-Amp factor								
4, All the other emissions not reported were too low to read and deemed to comply with FCC limit.								

802.11n20

Band Edge Test result								
EUT: UP BOX+			M/N: 3DP-25-4F					
Power: DC 24V from adapter								
Test date: 2016-05-28 Test site: 3m Chamber Tested by: Eric Huang								
Test mode: Tx Low								
Antenna polarity: Vertical								
Freq (MHz)	Read Level (dBuV/m)	Antenna Factor (dB/m)	Cable loss(dB)	Amp Factor (dB)	Result (dBuV/m)	Limit (dBuV/m)	Margin (dB)	Remark
2390	44.13	27.62	3.92	34.97	40.7	74	33.3	PK
2390	--	27.62	3.92	34.97	--	54	--	AV
Antenna Polarity: Horizontal								
2390	44.45	27.62	3.92	34.97	41.02	74	32.98	PK
2390	--	27.62	3.92	34.97	--	54	--	AV
Note:								
1, Spectrum Set for PK measure: RBW=1MHz, VBW=1MHz, Sweep time=Auto, Detector: PK								
2, Spectrum Set for AV measure: RBW=1MHz, VBW=3MHz, Sweep time=Auto, Detector: RMS								
3, Result = Read level + Antenna factor + cable loss-Amp factor								
4, All the other emissions not reported were too low to read and deemed to comply with FCC limit.								

Band Edge Test result								
EUT: UP BOX+			M/N: 3DP-25-4F					
Power: DC 24V from adapter								
Test date: 2016-05-28			Test site: 3m Chamber			Tested by: Eric Huang		
Test mode: Tx High								
Antenna polarity: Vertical								
Freq (MHz)	Read Level (dBuV/m)	Antenna Factor (dB/m)	Cable loss(dB)	Amp Factor (dB)	Result (dBuV/m)	Limit (dBuV/m)	Margin (dB)	Remark
2483.5	43.54	27.89	4	34.97	40.46	74	33.54	PK
2483.5		--	--	--	--	54	--	AV
Antenna Polarity: Horizontal								
2483.5	43.98	27.89	4	34.97	40.9	74	33.1	PK
2483.5		--	--	--	--	54	--	AV
Note:								
1, Spectrum Set for PK measure: RBW=1MHz, VBW=1MHz, Sweep time=Auto, Detector: PK								
2, Spectrum Set for AV measure: RBW=1MHz, VBW=3MHz, Sweep time=Auto, Detector: RMS								
3, Result = Read level + Antenna factor + cable loss-Amp factor								
4, All the other emissions not reported were too low to read and deemed to comply with FCC limit.								

11 Antenna Requirement

11.1 Standard Requirement

An intentional radiator shall be designed to ensure that no antenna other than that furnished by the responsible party shall be used with the device. The use of a permanently attached antenna or of an antenna that uses a unique coupling to the intentional radiator shall be considered sufficient to comply with the provisions of this Section. The manufacturer may design the unit so that a broken antenna can be replaced by the user, but the use of a standard antenna jack or electrical connector is prohibited.

11.2 Antenna Connected Construction

The antenna connector is unique antenna and no consideration of replacement. Please see EUT photo for details.

11.3 Result

The EUT antenna is external Antenna. It comply with the standard requirement.

12 Test setup photo

Photographs-Radiated Emission Test Setup in Chamber

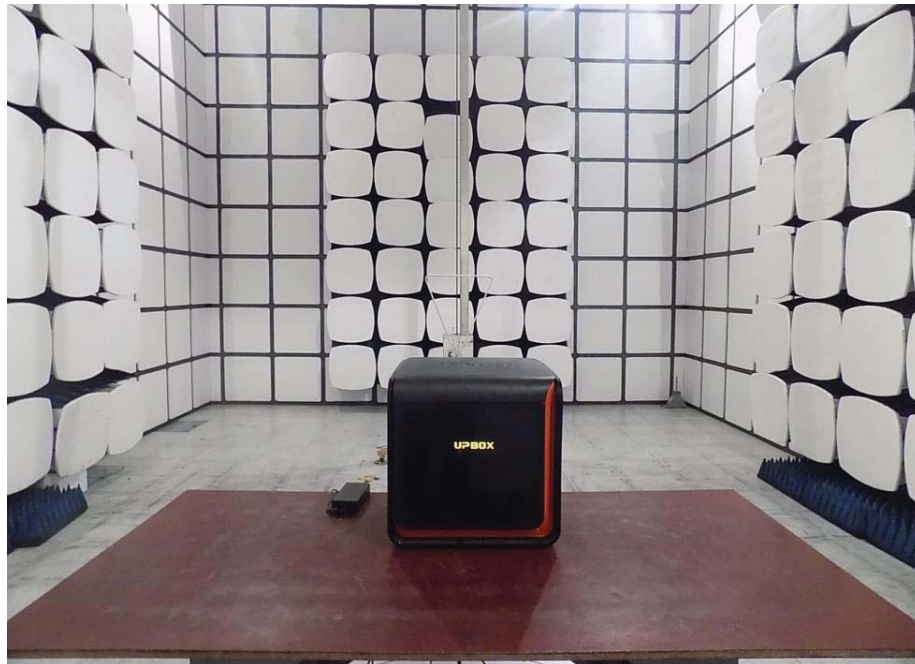

Photos of conducted emission

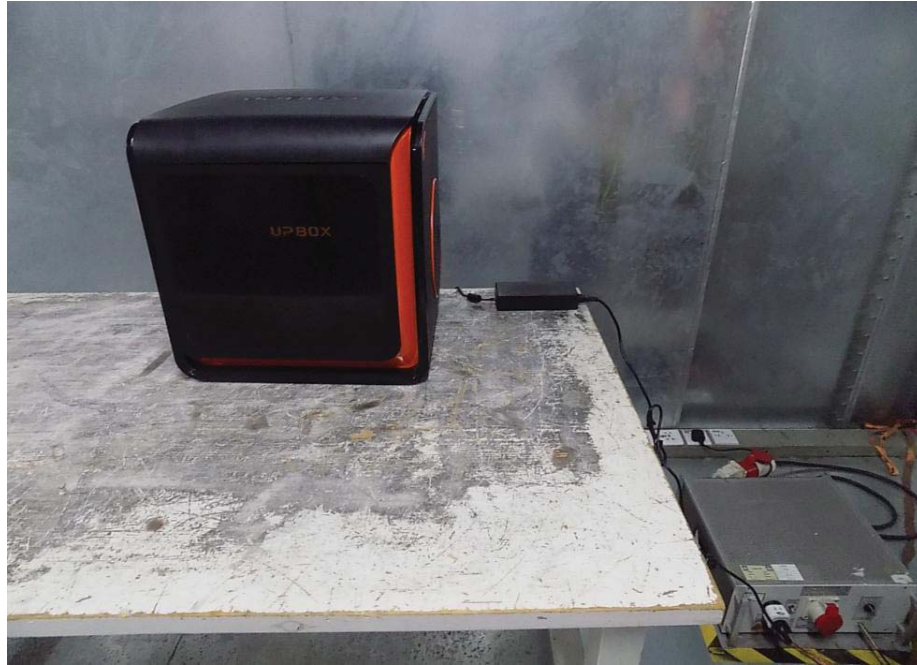

13 Photos of EUT





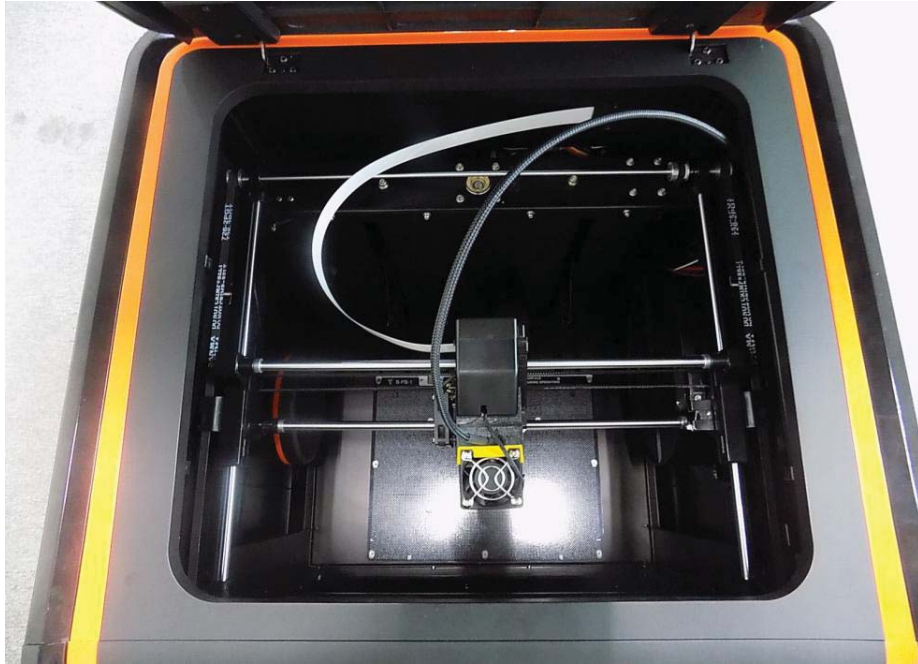

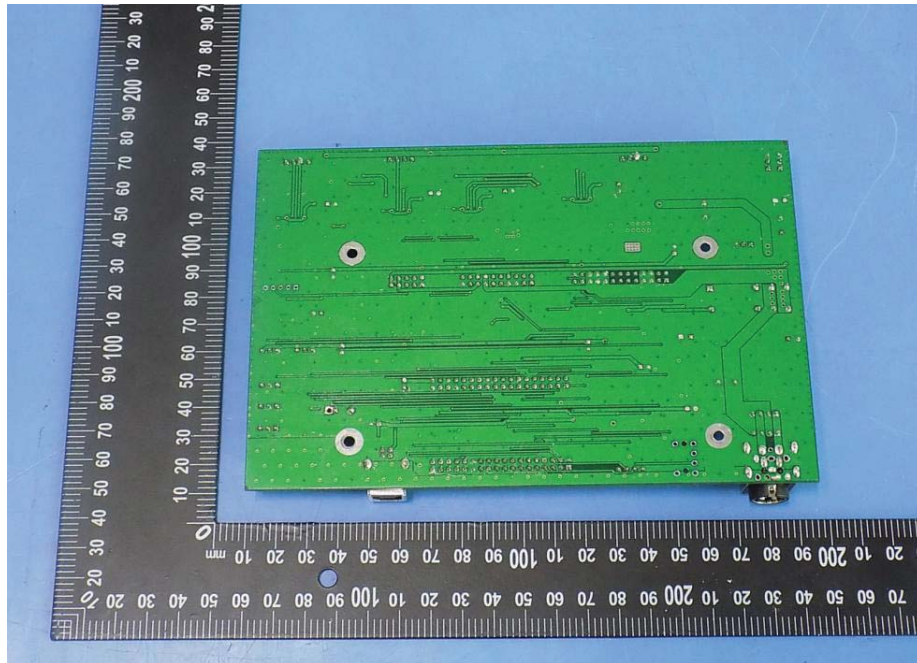
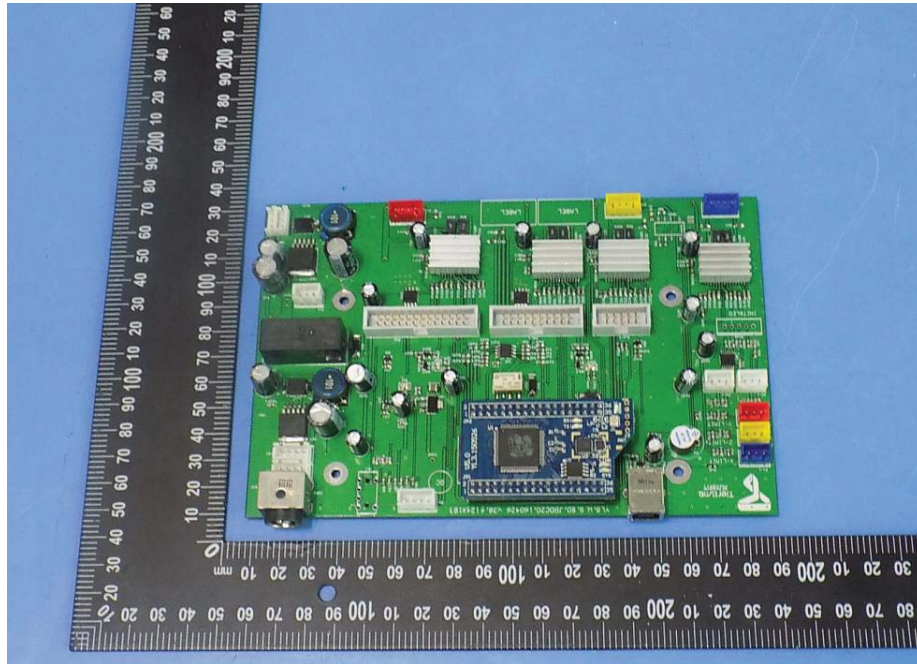

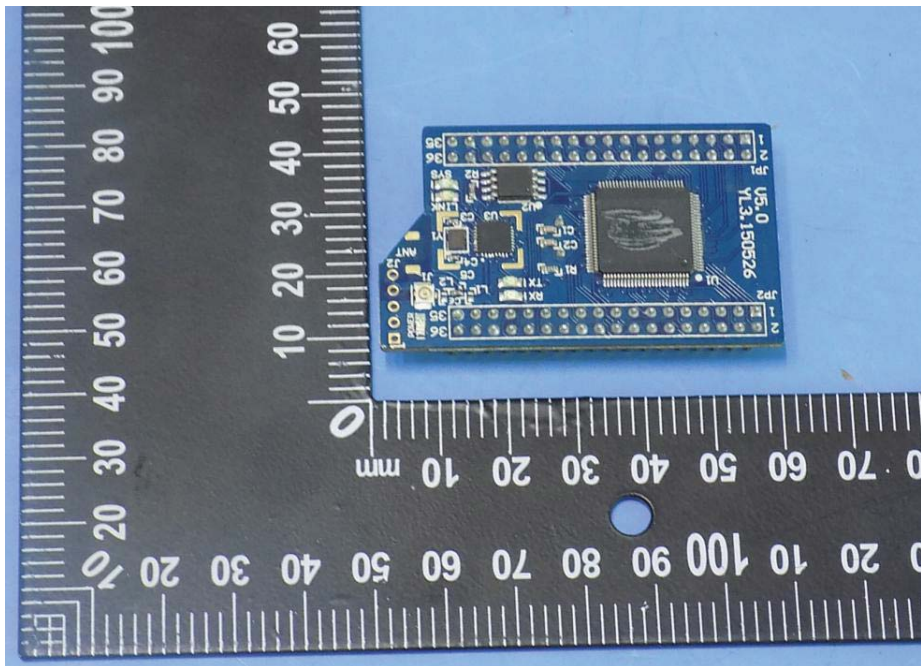
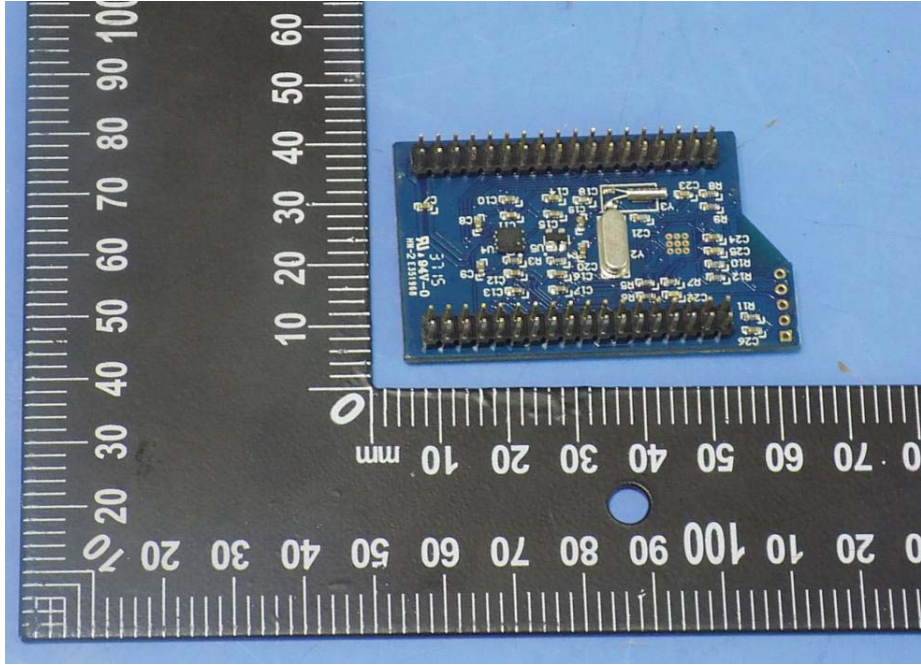

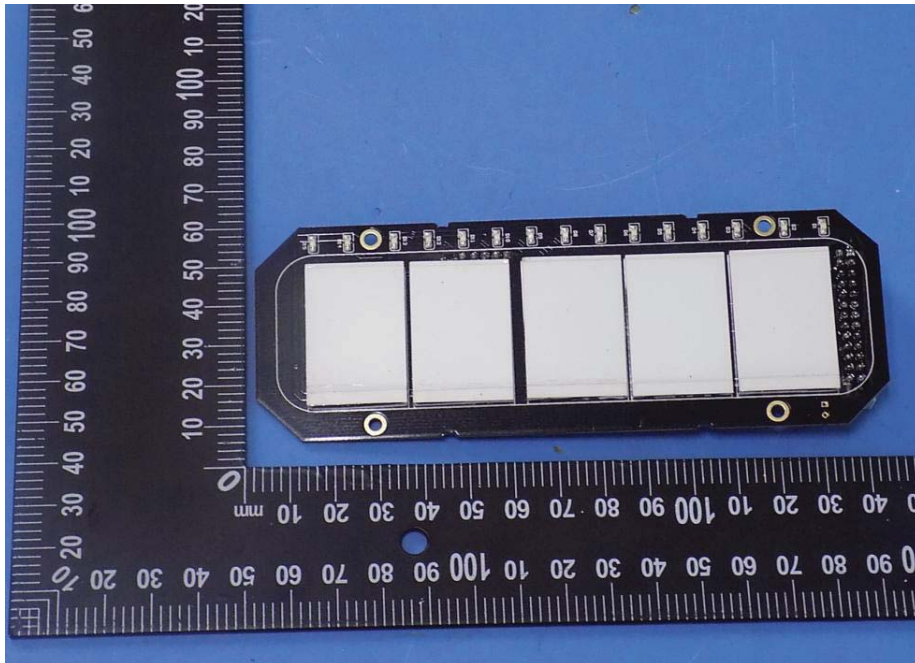
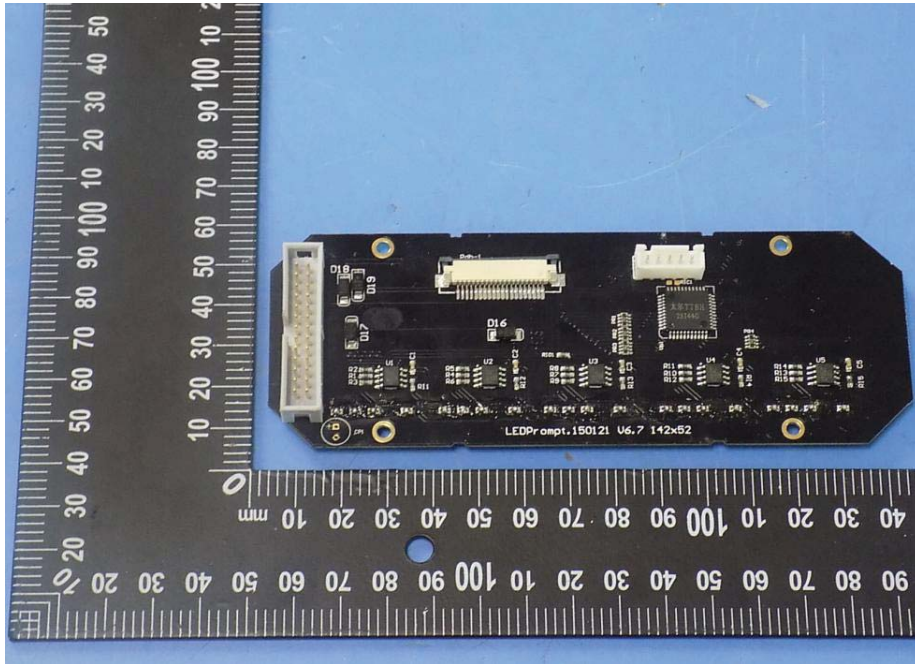

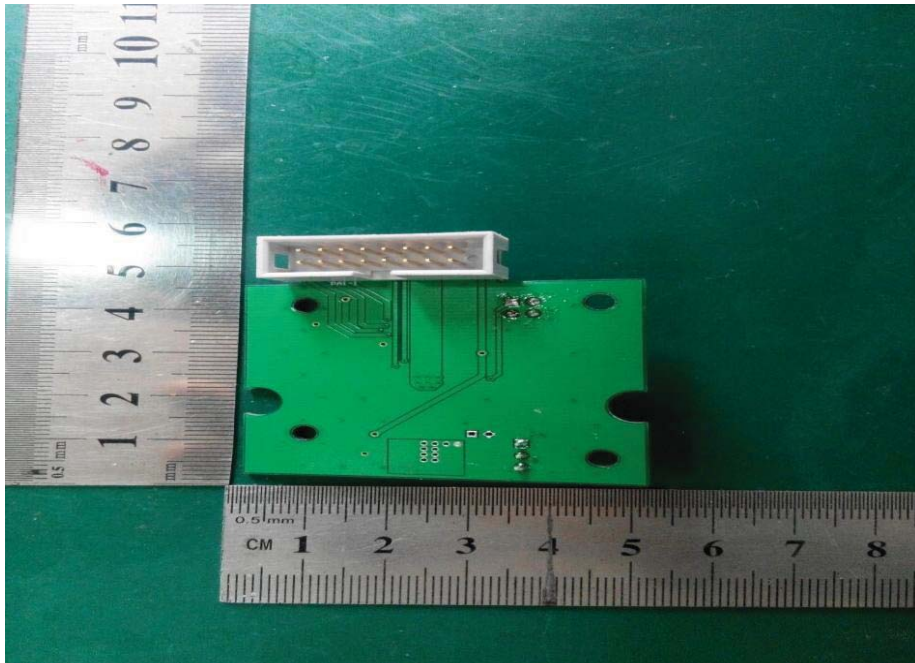
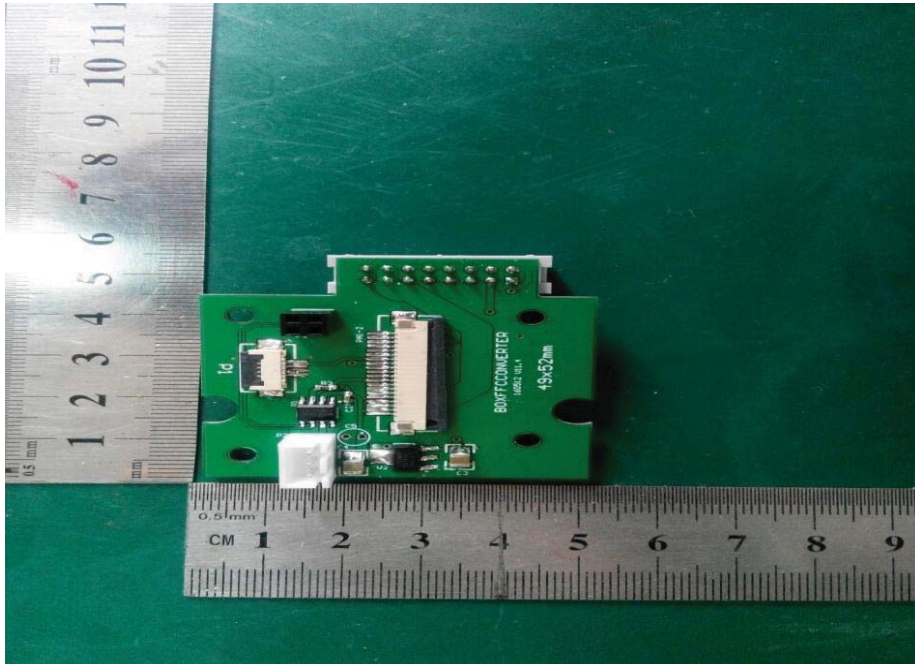

-----END OF THE REPORT-----