

TEST REPORT

Reference No..... : WTX23X02023511W005
FCC ID : 2AAH8-OSIDDV2
Applicant : Orpyx Medical Technologies Inc.
Address..... : Suite 205, 1240 - 20th Avenue S.E. Calgary, AB T2G 1M8 Canada
Manufacturer : The same as Applicant
Address..... : The same as Applicant
Product Name : Mobile Phone
Model No..... : OSIDDV2
Standards : FCC Part 15E
Date of Receipt sample : 2023-02-17
Date of Test..... : 2023-02-17 to 2023-03-10
Date of Issue : 2023-03-10
Test Report Form No. : WTX_Part 15EW
Test Result..... : **Pass**

Remarks:

The results shown in this test report refer only to the sample(s) tested, this test report cannot be reproduced, except in full, without prior written permission of the company. The report would be invalid without specific stamp of test institute and the signatures of approver.

Prepared By:

Waltek Testing Group (Shenzhen) Co., Ltd.

Address: 1/F., Room 101, Building 1, Hongwei Industrial Park, Liuxian 2nd Road,
Block 70 Bao'an District, Shenzhen, Guangdong, China

Tel.: +86-755-33663308 Fax.: +86-755-33663309 Email: sem@waltek.com.cn

Tested by:

Approved by:



Dashan Chen



Silin Chen

TABLE OF CONTENTS

1. GENERAL INFORMATION4
1.1 PRODUCT DESCRIPTION FOR EQUIPMENT UNDER TEST (EUT)4
1.2 TEST STANDARDS.....5
1.3 TEST METHODOLOGY5
1.4 EUT OPERATING DURING TEST.....5
1.5 TEST FACILITY5
1.6 EUT SETUP AND TEST MODE6
1.7 TEST EQUIPMENT LIST AND DETAILS7

2. SUMMARY OF TEST RESULTS.....8

3.DYNAMIC FREQUENCY SELECTION (DFS).....9
3.1 REQUIREMENT9
3.2 RADAR TEST WAVEFORMS10
3.3 CALIBRATION OF RADAR WAVEFORM13
3.4 TEST PROCEDURE16
3.5 TEST RESULTS.....17

EXHIBIT 1 - TEST SETUP PHOTOGRAPHS19

Report version

Version No.	Date of issue	Description
Rev.00	2023-03-10	Original
/	/	/

1. GENERAL INFORMATION

1.1 Product Description for Equipment Under Test (EUT)

General Description of EUT	
Product Name:	Mobile Phone
Trade Name:	Orpyx
Model No.:	OSIDDV2
Adding Model:	/
Rated Voltage:	DC3.85V
Battery Capacity:	4000mAh (15.4Wh)
Power Adapter:	TPA-46050200UU INPUT:AC100-240V 50/60Hz 0.3A OUTPUT:DC5V 2.0A
The EUT is only support slave without radar Detection function.	
<i>Note: The test data is gathered from a production sample provided by the manufacturer.</i>	

Technical Characteristics of EUT	
Support Standards:	802.11a, 802.11n(HT20), 802.11n(HT40), 802.11ac(VHT20), 802.11ac(VHT40), 802.11ac(VHT80)
Frequency Range:	5150-5250MHz, 5250-5350MHz, 5725-5850MHz
RF Output Power:	11.94dBm (Conducted)
Type of Modulation:	BPSK, QPSK, 16QAM, 64QAM, 256QAM
Type of Antenna:	PIFA Antenna
Antenna Gain:	-2.2dBi

1.2 Test Standards

The tests were performed according to following standards:

FCC Rules Part 15.407: General technical requirements.

ANSI C63.10-2013: American National Standard for Testing Unlicensed Wireless Devices.

KDB905462 D02: Compliance Measurement Procedures for Unlicensed-National Information Infrastructure Devices Operating in the 5250-5350MHz And 5470-5725MHz Bands Incorporating Dynamic Frequency Selection.

KDB905462 D03: U-Nii Client Devices Without Radar Detection Capability.

Maintenance of compliance is the responsibility of the manufacturer. Any modification of the product, which result in lowering the emission, should be checked to ensure compliance has been maintained.

Maintenance of compliance is the responsibility of the manufacturer. Any modification of the product, which result in lowering the emission, should be checked to ensure compliance has been maintained.

1.3 Test Methodology

All measurements contained in this report were conducted with KDB 905462 D02 UNII DFS Compliance Procedures New Rules v02.

1.4 EUT Operating during test

EUT was programmed to be in continuously transmitting mode. During the test, EUT operation to normal function and programs under WIN XP were executed.

1.5 Test Facility

Address of the test laboratory

Laboratory: Waltek Testing Group (Shenzhen) Co., Ltd.

Address: 1/F., Room 101, Building 1, Hongwei Industrial Park, Liuxian 2nd Road, Block 70 Bao'an District, Shenzhen, Guangdong, China

FCC – Registration No.: 125990

Waltek Testing Group (Shenzhen) Co., Ltd. EMC Laboratory has been registered and fully described in a report filed with the FCC (Federal Communications Commission). The acceptance letter from the FCC is maintained in our files. The Designation Number is CN5010, and Test Firm Registration Number is 125990.

Industry Canada (IC) Registration No.: 11464A

The 3m Semi-anechoic chamber of Waltek Testing Group (Shenzhen) Co., Ltd. has been registered by Certification and Engineering Bureau of Industry Canada for radio equipment testing with Registration No.: 11464A and the CAB identifier is CN0057.

1.6 EUT Setup and Test Mode

The EUT in this application is a client device without radar detection capability and indicate the FCC identifier for the Master U-NII Device .During the test, the product works on the designated test channel and transmits normal data to the master.

Messages for communication between Master and Client Devices: 0101010101.....(Continuous cycle.)

The type of system architecture for the device in this application is IP based, more detailed description as follows:

Test Mode List		
Test Mode	Description	Remark
TM1	802.11ac(VHT80)	5290MHz

EUT Cable List and Details			
Cable Description	Length (m)	Shielded/Unshielded	With / Without Core
/	/	/	/

Special Cable List and Details			
Cable Description	Length (m)	Shielded/Unshielded	With / Without Ferrite
/	/	/	/

Auxiliary Equipment List and Details			
Description	Manufacturer	Model	Serial Number
/	/	/	/

1.7 Test Equipment List and Details

No.	Description	Manufacturer	Model	Serial No.	Cal Date	Due. Date
SEMT-1075	Communication Tester	Rohde & Schwarz	CMW500	148650	2022-03-22	2023-03-21
SEMT-1063	GSM Tester	Rohde & Schwarz	CMU200	114403	2022-03-22	2023-03-21
SEMT-1072	Spectrum Analyzer	Agilent	E4407B	MY41440400	2022-03-25	2023-03-24
SEMT-1079	Spectrum Analyzer	Agilent	N9020A	US47140102	2022-03-22	2023-03-21
SMET-1313	Spectrum Analyzer	Agilent	N9020A	MY54320548	2022-03-22	2023-03-21
SEMT-1080	Signal Generator	Agilent	83752A	3610A01453	2022-03-22	2023-03-21
SEMT-1081	Vector Signal Generator	Agilent	N5182A	MY47070202	2022-03-22	2023-03-21
SEMT-1028	Power Divider	Weinschel	1506A	PM204	2022-03-22	2023-03-21
SEMT-C001	Cable	Zheng DI	LL142-07-07-10M(A)	/	/	/
SEMT-C002	Cable	Zheng DI	ZT40-2.92J-2.92J-6M	/	/	/
SEMT-C003	Cable	Zheng DI	ZT40-2.92J-2.92J-2.5M	/	/	/
SEMT-C004	Cable	Zheng DI	2M0RFC	/	/	/
SEMT-C005	Cable	Zheng DI	1M0RFC	/	/	/
SEMT-C006	Cable	Zheng DI	1M0RFC	/	/	/

Software List			
Description	Manufacturer	Model	Version
EMI Test Software (Radiated Emission)*	Farad	EZ-EMC	RA-03A1

*Remark: indicates software version used in the compliance certification testing.

2. SUMMARY OF TEST RESULTS

FCC Rules	Description of Test Item	Result
§15.407(h)	Dynamic Frequency Selection (DFS)	Pass

N/A: Not applicable.

3.Dynamic Frequency Selection (DFS)

3.1 Requirement

Table 1: Applicability of DFS Requirements Prior to Use of a Channel

Requirement	Operational Mode		
	Master	Client Without Radar Detection	Client With Radar Detection
Non-Occupancy Period	Yes	Not required	Yes
DFS Detection Threshold	Yes	Not required	Yes
Channel Availability Check Time	Yes	Not required	Not required
U-NII Detection Bandwidth	Yes	Not required	Yes

Table 2: Applicability of DFS requirements during normal operation

Requirement	Operational Mode	
	Master Device or Client with Radar Detection	Client Without Radar Detection
DFS Detection Threshold	Yes	Not required
Channel Closing Transmission Time	Yes	Yes
Channel Move Time	Yes	Yes
U-NII Detection Bandwidth	Yes	Not required

Additional requirements for devices with multiple bandwidth	Master Device or Client with Radar Detection	Client Without Radar Detection
U-NII Detection Bandwidth and Statistical Performance Check	All BW modes must be tested	Not required
Channel Move Time and Channel Closing Transmission	Test using widest BW mode available	Test using the widest BW mode available for the link
All other tests	Any single BW mode	Not required

Note: Frequencies selected for statistical performance check (Section 7.8.4) should include several frequencies within the radar detection bandwidth and frequencies near the edge of the radar detection bandwidth. For 802.11 devices it is suggested to select frequencies in each of the bonded 20MHz channels and the channel center frequency.

LIMIT

1. DFS Detection Thresholds

Table 3: DFS Detection Thresholds for Master Devices and Client Devices With Radar Detection

Maximum Transmit Power	Value (See Notes 1, 2, and 3)
EIRP \geq 200 milliwatt	-64dBm
EIRP < 200 milliwatt and power spectral density < 10 dBm/MHz	-62dBm
EIRP < 200 milliwatt that do not meet the power spectral density requirement	-64dBm

Note 1: This is the level at the input of the receiver assuming a 0dBi receive antenna.
Note 2: Throughout these test procedures an additional 1dB has been added to the amplitude of the test transmission waveforms to account for variations in measurement equipment. This will ensure that the test signal is at or above the detection threshold level to trigger a DFS response.
Note3: EIRP is based on the highest antenna gain. For MIMO devices refer to KDB Publication 662911 D01.

2. DFS Response Requirements

Table 4: DFS Response Requirement Values

Parameter	Value
Non-occupancy period	Minimum 30 minutes
Channel Availability Check Time	60 seconds
Channel Move Time	10 seconds See Note 1.
Channel Closing Transmission Time	200 milliseconds + an aggregate of 60 milliseconds over remaining 10 second period. See Notes 1 and 2.
U-NII Detection Bandwidth	Minimum 100% of the U-NII 99% transmission power bandwidth. See Note 3.

Note 1: Channel Move Time and the Channel Closing Transmission Time should be performed with Radar Type 0. The measurement timing begins at the end of the Radar Type 0 burst.
Note 2: The Channel Closing Transmission Time is comprised of 200 milliseconds starting at the beginning of the Channel Move Time plus any additional intermittent control signals required facilitating a Channel move (an aggregate of 60 milliseconds) during the remainder of the 10 second period. The aggregate duration of control signals will not count quiet periods in between transmissions.
Note 3: During the U-NII Detection Bandwidth detection test, radar type 0 should be used. For each frequency step the minimum percentage of detection is 90 percent. Measurements are performed with no data traffic.

3.2 RADAR TEST WAVEFORMS

This section provides the parameters for required test waveforms, minimum percentage of successful detections, and the minimum number of trials that must be used for determining DFS conformance. Step intervals of 0.1 microsecond for Pulse Width, 1 microsecond for PRI, 1 MHz for chirp width and 1 for the number of pulses will be utilized for the random determination of specific test waveforms.

Table 5 Short Pulse Radar Test Waveforms

Radar Type	Pulse Width (μsec)	PRI (μsec)	Number of Pulses	Minimum Percentage of Successful Detection	Minimum Number of Trials
0	1	1428	18	See Note 1	See Note 1
1	1	Test A: 15 unique PRI values randomly selected from the list of 23 PRI values in Table 5a	Roundup $\left\{ \left(\frac{1}{360} \right) \cdot \left(\frac{19 \cdot 10^6}{PRI_{\mu\text{sec}}} \right) \right\}$	60%	30
		Test B: 15 unique PRI values randomly selected within the range of 518-3066 μsec, with a minimum increment of 1 μsec, excluding PRI values selected in Test A			
2	1-5	150-230	23-29	60%	30
3	6-10	200-500	16-18	60%	30
4	11-20	200-500	12-16	60%	30
Aggregate (Radar Types 1-4)				80%	120
Note 1: Short Pulse Radar Type 0 should be used for the detection bandwidth test, channel move time, and channel closing time tests.					

A minimum of 30 unique waveforms are required for each of the Short Pulse Radar Types 2 through 4. If more than 30 waveforms are used for Short Pulse Radar Types 2 through 4, then each additional waveform must also be unique and not repeated from the previous waveforms. If more than 30 waveforms are used for Short Pulse Radar Type 1, then each additional waveform is generated with Test B and must also be unique and not repeated from the previous waveforms in Tests A or B. For example if in Short Pulse Radar Type 1 Test B a PRI of 3066 μsec is selected, the number of pulses

$$\left\{ \left(\frac{1}{360} \right) \cdot \left(\frac{19 \cdot 10^6}{3066} \right) \right\}$$

would be Round up = Round up {17.2} = 18.

Table 5a - Pulse Repetition Intervals Values for Test A

Pulse Repetition Frequency Number	Pulse Repetition Frequency (Pulses Per Second)	Pulse Repetition Interval (Microseconds)
1	1930.5	518
2	1858.7	538
3	1792.1	558
4	1730.1	578
5	1672.2	598
6	1618.1	618
7	1567.4	638
8	1519.8	658
9	1474.9	678
10	1432.7	698
11	1392.8	718
12	1355	738
13	1319.3	758
14	1285.3	778
15	1253.1	798
16	1222.5	818
17	1193.3	838
18	1165.6	858
19	1139	878
20	1113.6	898
21	1089.3	918
22	1066.1	938
23	326.2	3066

Table 6 – Long Pulse Radar Test Waveform

Radar Type	Pulse Width (µsec)	Chirp Width (MHz)	PRI (µsec)	Number of Pulses per Burst	Number of Bursts	Minimum Percentage of Successful Detection	Minimum Number of Trials
5	50-100	5-20	1000-2000	1-3	8-20	80%	30

The parameters for this waveforms are randomly chosen. Thirty unique waveforms are required for the Long Pulse Radar Type waveforms. If more than 30 waveforms are used for the Long Pulse Radar Type wave forms, then each additional waveform must also be unique and not repeated from the previous waveforms.

Table 7 – Frequency Hopping Radar Test Waveform

Radar Type	Pulse Width (μsec)	PRI (μsec)	Pulses per Hop	Hopping Rate (kHz)	Hopping Sequence Length	Minimum Percentage of Successful	Minimum Number of Trials
6	1	333	9	0.333	300	70%	30

For the Frequency Hopping Radar Type, the same Burst parameters are used for each wave form. The hopping sequence is different for each wave form and a 100-length segment is selected from the hopping sequence defined by the following algorithm:

The first frequency in a hopping sequence is selected randomly from the group of 475 integer frequencies from 5250–5724MHz. Next, the frequency that was just chosen is removed from the group and a frequency is randomly selected from the remaining 474 frequencies in the group. This process continues until all 475 frequencies are chosen for the set. For selection of a random frequency, the frequencies remaining within the group are always treated as equally likely.

3.3 Calibration of Radar Waveform

Radar Waveform Calibration Procedure

- 1) A 50 ohm load is connected in place of the spectrum analyzer, and the spectrum analyzer is connected to place of the master
- 2) The interference Radar Detection Threshold Level is $-62\text{dBm} + 0\text{dBi} + 1\text{dB} = -61\text{dBm}$ that had been taken into account the output power range and antenna gain.
- 3) The following equipment setup was used to calibrate the conducted radar waveform. A vector signal generator was utilized to establish the test signal level for radar type 0. During this process there were no transmissions by either the master or client device. The spectrum analyzer was switched to the zero spans (time domain) at the frequency of the radar waveform generator. Peak detection was used. The spectrum analyzer resolution bandwidth (RBW) and video bandwidth (VBW) were set to 3MHz. The spectrum analyzer had offset -1.0dB to compensate RF cable loss 1.0dB.
- 4) The vector signal generator amplitude was set so that the power level measured at the spectrum analyzer was $-62\text{dBm} + 0\text{dBi} + 1\text{dB} = -61\text{dBm}$. Capture the spectrum analyzer plots on short pulse radar waveform.

Conducted Calibration Setup

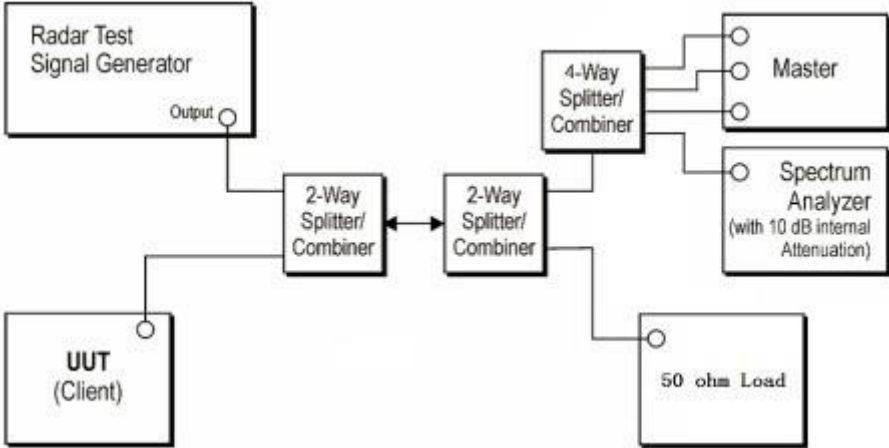

Radar Waveform Calibration Result

Radar Type 0 (80MHz / 5290Hz)

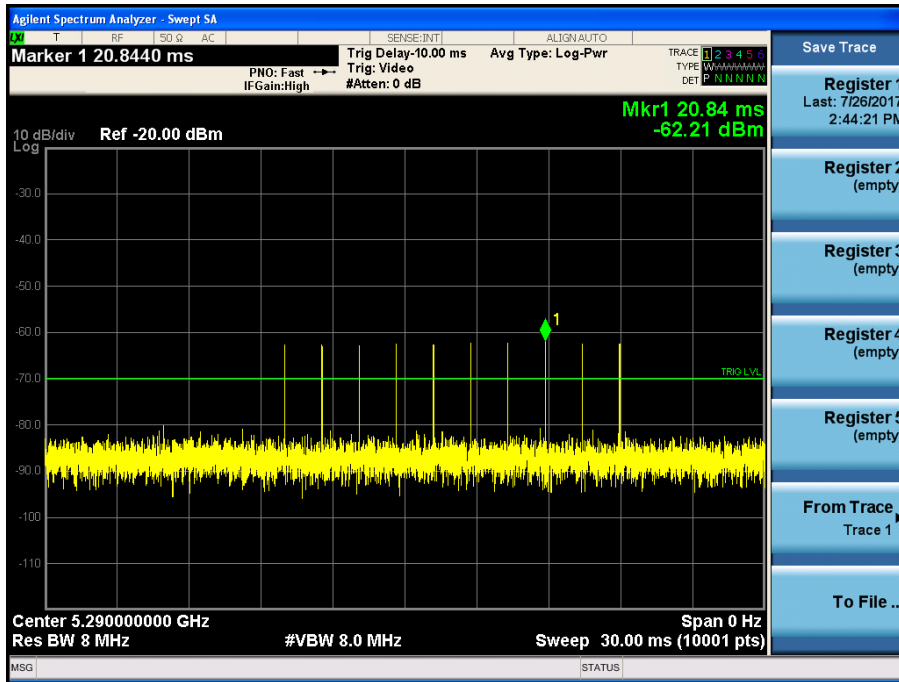

Data transmitting calibration

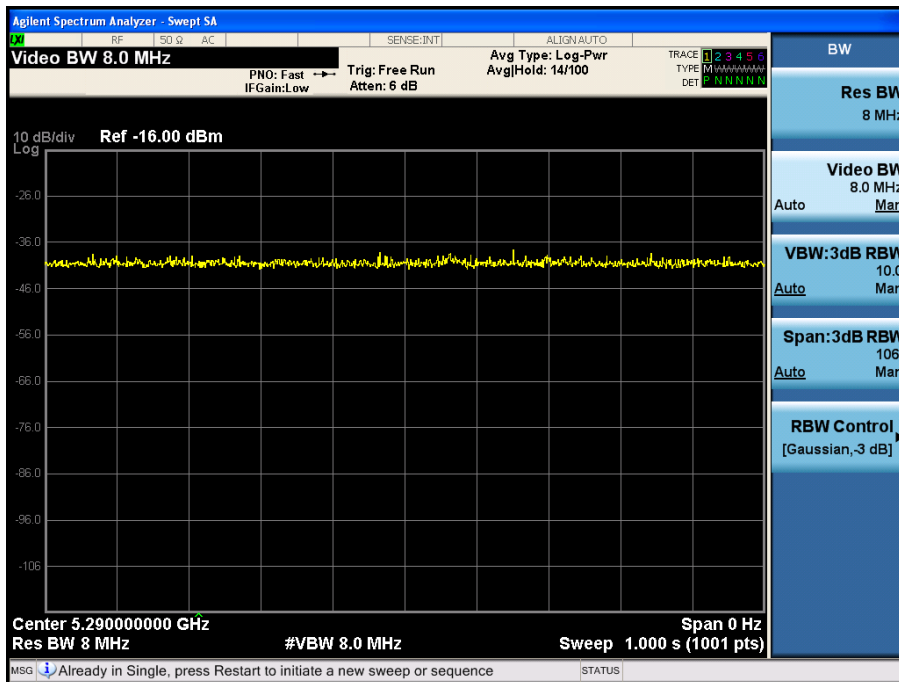

TEST CONFIGURATION

Setup for Client with injection at the Master

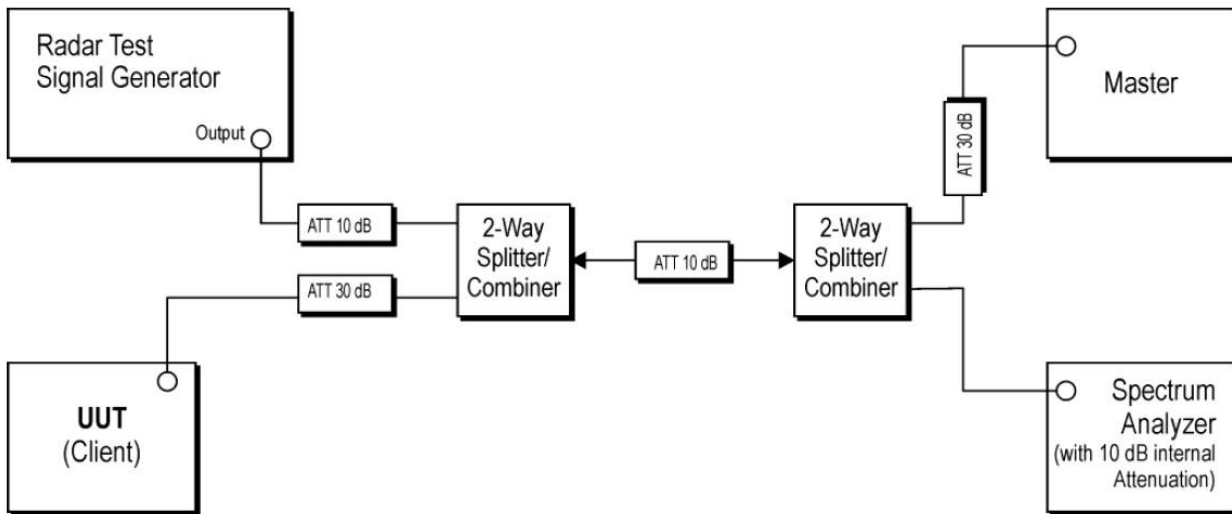

3.4 TEST PROCEDURE

1. The radar pulse generator is setup to provide a pulse at frequency that the master and client are operating. A type 0 radar pulse with a 1us pulse width and a 1428us PRI is used for the testing.
2. The vector signal generator is adjusted to provide the radar burst (18 pulses) at the level of approximately -61dBm at the antenna port of the master device
3. A trigger is provided from the pulse generator to the DFS monitoring system in order to capture the traffic and the occurrence of the radar pulse.
4. EUT will associate with the master at channel. The file "iperf.exe" specified by the FCC is streamed from the PC 2 through the master and the client device to the PC 1 and played in full motion video using Media Player Classic Ver. 6.4.8.6 in order to properly load the network for the entire period of the test.
5. When radar burst with a level equal to the DFS Detection Threshold +1dB is generated on the operating channel of the U-NII device. At time T0 the radar waveform generator sends a burst of pulse of the radar waveform at Detection Threshold +1dB.
6. Observe the transmissions of the EUT at the end of the radar Burst on the Operating Channel Measure and record the transmissions from the UUT during the observation time (Channel Move Time). One 15 seconds plot is reported for the Short Pulse Radar Type 0. The plot for the Short Pulse Radar Types

start at the end of the radar burst. The Channel Move Time will be calculated based on the zoom in 600ms plot of the Short Pulse Radar Type

7. Measurement of the aggregate duration of the Channel Closed Transmission Time method. With the spectrum analyzer set to zero span tuned to the center frequency of the EUT operating channel at the radar simulated frequency, peak detection, and max hold, the dwell time per bin is given by: $Dwell (0.3ms) = S (12000ms) / B (4000)$; where Dwell is the dwell time per spectrum analyzer sampling bin, S is sweep time and B is the number of spectrum analyzer sampling bins. An upper bound of the aggregate duration of the intermittent control signals of Channel Closing Transmission Time is calculated by: $C (ms) = N \times Dwell (0.3ms)$; where C is the Closing Time, N is the number of spectrum analyzer sampling bins (intermittent control signals) showing a U-NII transmission and Dwell is the dwell time per bin.
8. Measurement the EUT for more than 30 minutes following the channel move time to verify that no transmission or beacons occur on this channel.

3.5 TEST RESULTS

BW/Channel	Test Item	Test Result(s)	Limit	Result
80MHz/5290MHz	Channel Move Time	2.0714	<10s	Pass
	Channel Closing Transmission Time	0.2156	<0.06s	Pass

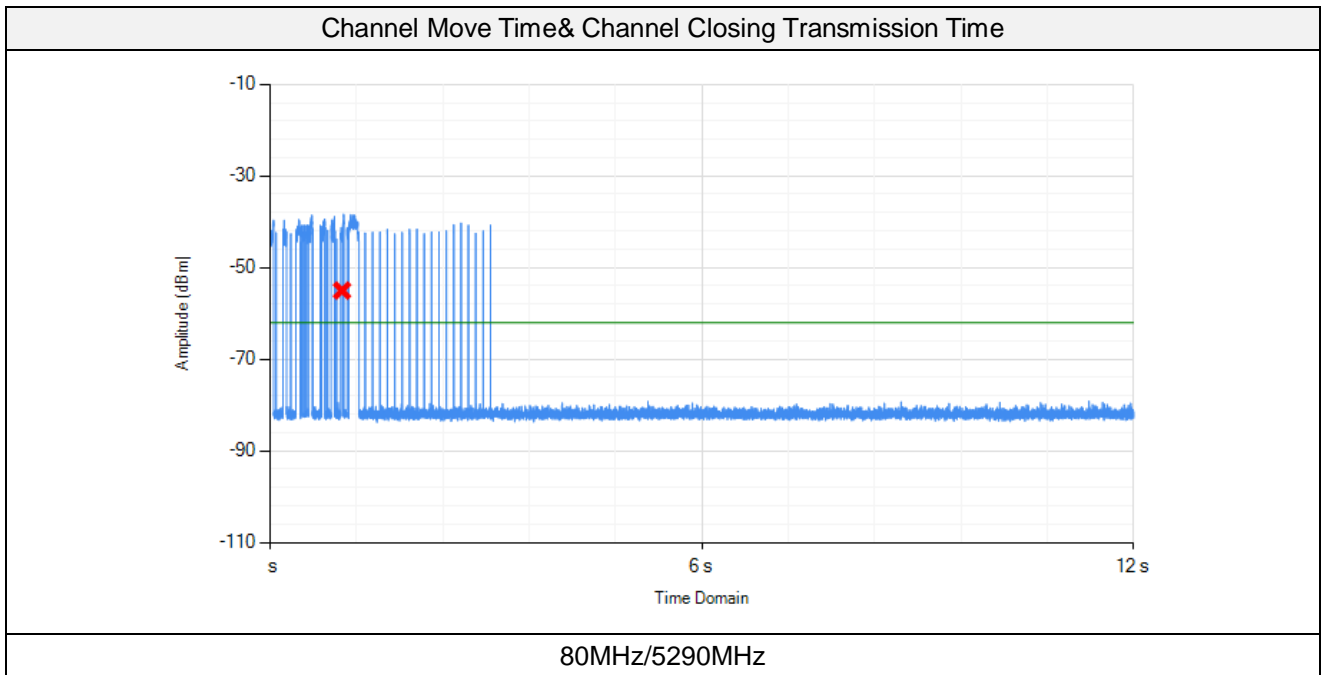

Non-occupancy Observer

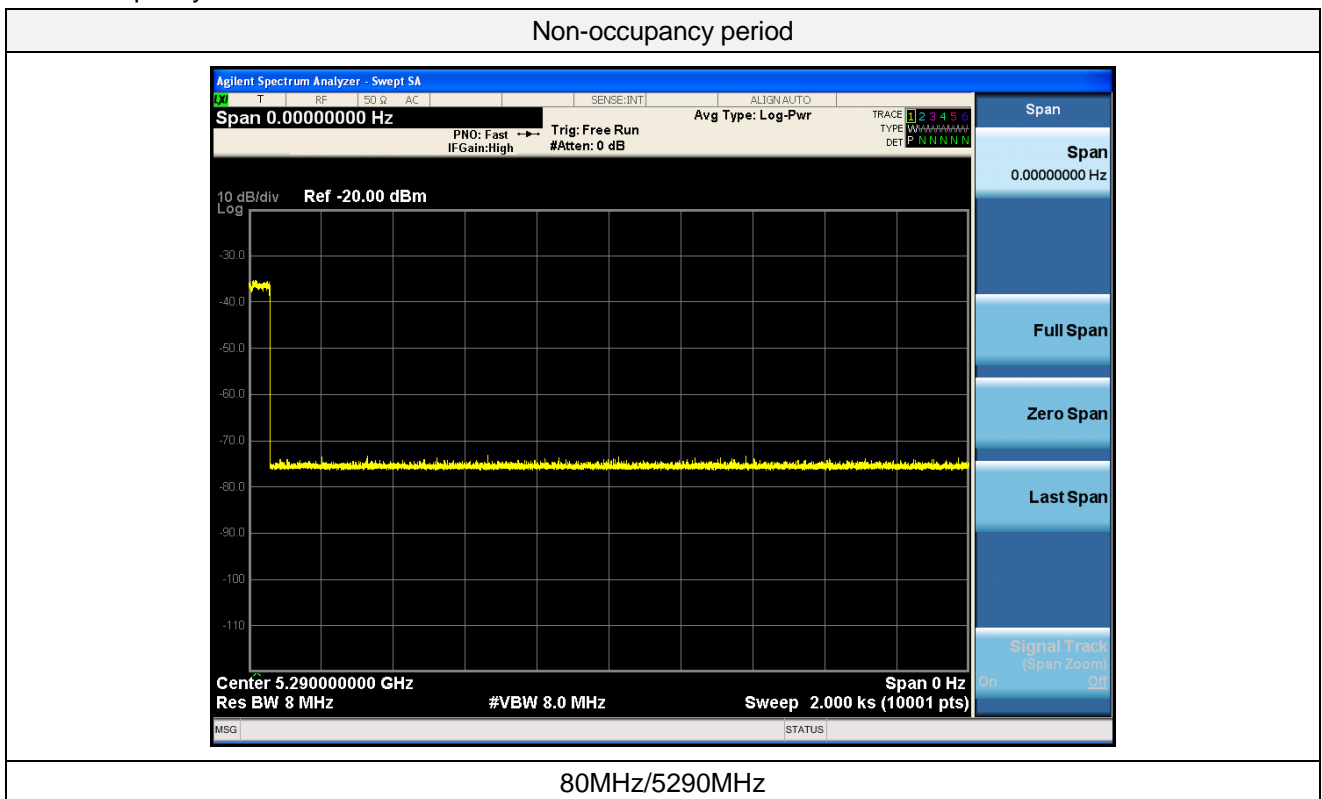

EXHIBIT 1 - TEST SETUP PHOTOGRAPHS



***** END OF REPORT *****