



SAAB

Överföring av dokument i elektronisk form

Detta dokument är en elektronisk kopia.

Vid konvertering eller överföring i elektronisk form kan dokumentet bli förvanskat.

Det fastställda pappersoriginalet är det gällande dokumentet.

Transfer of document in electronic form

This document is an electronic copy of the original.

When converting or transferring the document into electronic form, it could be distorted.

The original paper document is to be considered the valid document.

Saab AB (publ) Support and Services

Postal address

Box 360
SE-831 25 Östersund
Sweden

Visiting address

Storlienvägen 56

Telephone

+46 63 15 60 00

Telefax

+46 63 15 61 99

Registered office

Linköping

Registered No

556036-0793

VAT No

SE556036079301

www.saabgroup.com

We are represented in

Arboga, Göteborg, Lidköping, Linköping, Ljungbyhed, Norrtälje, Nyköping,
Stockholm, Uppsala, Växjö, Äryd, Örebro, Östersund

Distribution
3D-Radar AS
Kløbuveien 196B
7037 Trondheim
Norge
Copy
OFLV archive

Document
Test Report
Date
May 14, 2013
Prepared
OFLBIA, Björn Olsson
Senior EMC engineer

Ref. No
EMC-Osd-13-0283-01
Supersedes

Page
1(31)

Title

EMC test of GeoScope Mk 4 radar with antenna DX1821

Summary:

The object of the test is to show compliance with the emission requirements of Federal Communications Commission (FCC) Part 15 Subpart F and Industry Canada (IC) RSS-220 for ground penetrating radars (GPR) using ultra wideband (UWB) technology.

The EUT complied with the requirement of radiated emissions given in FCC Part 15 Subpart F and IC RSS-220, measured in the frequency range 30 MHz – 18 GHz.

The EUT also fulfilled the requirements of frequency notching and frequency step parameters in the FCC Waiver DA 12-41, dated January 11, 2012.

The tests have been performed at an Open Area Test Site (OATS). The test site is registered at FCC with the registration number 389317 and at IC with the site number 4660C-1.

Approved:

[The original is signed]

Lennart Hamberg
Technical Manager

This report may not be reproduced other than in full, except with the prior written approval of the issuing laboratory.

Saab AB (publ.), Support and Services

Box 360. SE-831 25 Östersund, Sweden. Visitors: Storlienvägen 56. Telephone: +46 63 15 61 00. Telefax: +46 63 15 61 99

Contents

1 General information	3
2 Test methods and results	4
2.1 Results	4
2.2 Applicable documents	4
3 Equipment under test (EUT).....	5
3.1 Identification of equipment under test	5
3.2 General configuration of the EUT	6
3.3 Operation of EUT during tests.....	7
4 Test site.....	8
4.1 Description.....	8
4.2 Ambient signals	8
5 Results	9
5.1 Measurement of radiated emission, 30 MHz – 960 MHz	9
5.2 Measurement of radiated emission, 960 MHz – 18 GHz.....	14
5.3 Measurement of UWB bandwidth and peak emissions	24

1 General information

Date of test:	April 22 and 23, 2013
Location of the test:	Saab AB Storlienvägen 56 SE-831 52 Östersund Sweden
Test performed by:	Björn Olsson, Saab AB
Client:	3D-Radar AS Kløbuveien 196B 7037 Trondheim Norway
Client's observer:	Egil Eide, 3D-Radar AS

2 Test methods and results

2.1 Results

The test results in this report apply only for the tested EUT.

EMISSION REQUIREMENTS ACCORDING TO FCC Part 15 Subpart F and IC RSS-220				
Environmental phenomena	Test method	Requirement	Result	Comments
Radiated emission 30 MHz – 960 MHz	ANSI C63.4	FCC 15.209 IC RSS-220, section 3.4	PASS	
Radiated emission 960 MHz – 18 GHz	FCC 02-48 IC RSS-220	FCC 15.509 (d) IC RSS-220, section 6.2.1(d)	PASS	
Radiated emission 1164 MHz – 1240 MHz 1559 MHz – 1610 MHz	FCC 02-48 IC RSS-220	FCC 15.509 (e) IC RSS-220, section 6.2.1(e)	PASS	
UWB definition		FCC 15.503 (a) 15.509(a) IC RSS-220, section 6.2.1(a)	PASS	f _M : 770.8 MHz f _L : 286.8 MHz f _H : 1583 MHz f _C : 934.9 MHz
Peak emission at f _M	FCC 02-48 IC RSS-220	FCC 15.509 (f) IC RSS-220, section 6.2.1(g)	PASS	

2.2 Applicable documents

ANSI C63.4	15 September, 2009	American National Standard for Methods of Measurement of Radio-Noise Emissions from Low-Voltage Electrical and Electronic Equipment in the range of 9 kHz to 40 GHz
FCC CFR 47 Part 15	20 April, 2013	Radio Frequency Devices
FCC 02-48	22 April, 2002	Revision of Part 15 of the Commission's Rules Regarding Ultra-Wideband Transmission Systems
DA 12-41	11 January, 2012	FCC Waiver
IC RS-Gen	December 2010	General requirements and Information for the Certification of Radio Apparatus
IC RSS-220	March 2009	Devices Using Ultra-Wideband (UWB) Technology

3 Equipment under test (EUT)

3.1 Identification of equipment under test

Description:	Ground penetrating radar antenna
UWB subclass:	Ground Penetrating Radar (GPR)
Manufacturer:	3D-Radar AS
Model name:	GeoScope Mk 4 with antenna DX1821
Serial No GeoScope:	44044
Serial No antenna:	6161
Build state:	Production samples

The following configuration settings in the EUT were used:

File:	systemconfigFCC.txt
Revision:	2220
Date:	23 April, 2013

3.2 General configuration of the EUT

The antenna was attached to the GeoScope by a cable supplied by the customer. The GeoScope was placed beside the test area. See also Picture 1 and 2 for a description of the setup.

The GeoScope unit was connected through a shielded Ethernet cable to a PC placed approximately 10 m from the test area.

The measurements were performed with the stepping frequency function in the EUT active.

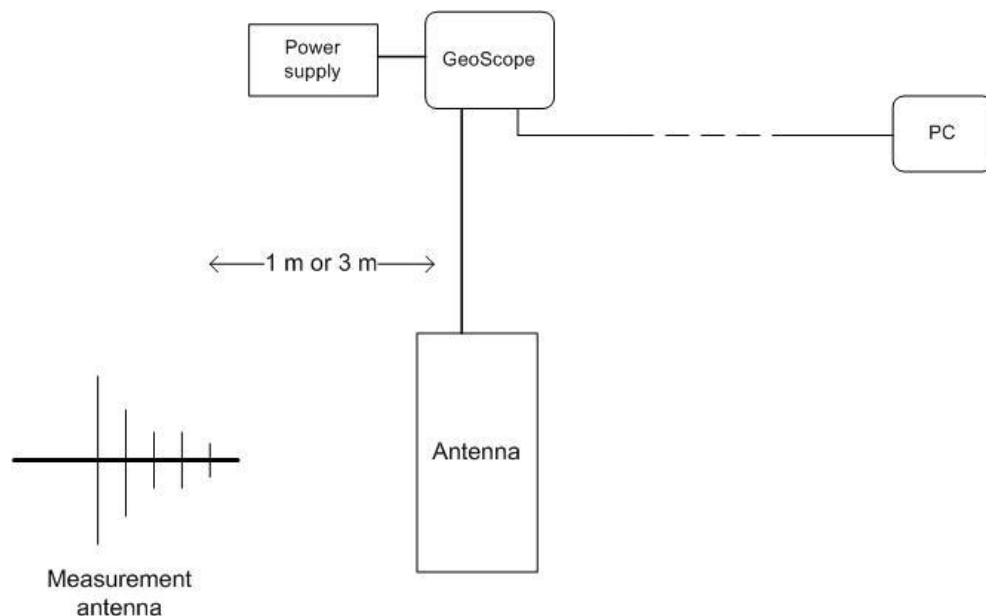

Picture 1. Schematic illustration of the EUT setup.



Picture 2. The GeoScope with its power supply unit placed beside the test area.

3.3 Operation of EUT during tests

The EUT was gathering data like in normal operation. The data was presented on the PC.

4 Test site

4.1 Description

The measurements were all performed on a weather protected open area test site (OATS) that was modified with a flat sand bed located in the ground plane. The depth of the sand bed was more than 0.5 m. The EUT was positioned on the sand bed with no ground plane beneath.

At frequencies below 960 MHz the measurement distance from the antenna to the EUT was 3 m. The measurement receiver and related equipment, such as a PC and equipment for remote control, were placed next to the test site approximately 10 m from the antenna.

At frequencies above 960 MHz the measurement distance from the antenna to the EUT was 1 m. The measurement receiver and a preamplifier were placed next to the measurement antenna while other related equipment was placed next to the site.

4.2 Ambient signals

A number of ambient signals were frequently detected in the different frequency ranges where measurements were made, see table below. Additionally, many signals of short-term duration were found. Each measurement signal close to or above the limit was examined if ambient or related to the EUT.

Frequency	Service
87 MHz – 108 MHz	FM Broadcast
390 MHz – 395 MHz	Mobile radio (TETRA)
470 MHz – 790 MHz	Television
876 MHz – 960 MHz	Mobile phones (GSM)
960 MHz – 1164 MHz	Aeronautical radio
1.3 GHz	Radar system
1.7 GHz – 2.2 GHz	Mobile phones (DECT, GSM, W-CDMA)
2.4 GHz – 2.5 GHz	Wireless-LAN

5 Results

5.1 Measurement of radiated emission, 30 MHz – 960 MHz

5.1.1 Requirements according to FCC 15.509 (d) and IC RSS-220

Radiated emission from the EUT in the frequency range 30 MHz to 960 MHz shall not exceed the limit as specified below.

Frequency range	Limit
30 – 88 MHz	40 dB μ V/m
88 – 216 MHz	43.5 dB μ V/m
216 – 960 MHz	46 dB μ V/m

5.1.2 Requirements according to FCC Waiver DA 12-41, dated January 11, 2012

The radar device shall implement frequency notching to avoid placing intentional transmissions in the band 608 MHz to 614 MHz.

5.1.3 Procedures

The radiated emission was measured on an Open Area Test Site (OATS) with 3 meters measuring distance as described in section 4.1, see Picture 3.

The EUT was configured and the test was performed in accordance with ANSI C63.4.

The test was initiated with a pre-scan with peak detector in the frequency range 30 MHz to 960 MHz. The emission level was measured in 64 different combinations of 16 EUT angle positions plus vertical and horizontal polarisation and two antenna heights. For each position the EUT was turned manually. The antenna height was changed in two steps at 1.0 m and 2.5 m.

A measurement software was used to add antenna factors and cable attenuation and to form a composite trace of the peak field strength.

EUT positions and frequencies with the highest emission were selected based on the pre-scan. EUT angle, antenna height and antenna polarisation were thereafter adjusted in order to find the highest emission level. The antenna height was changed between 1 m and 4 m. At these maximized positions quasi peak values were measured.



Picture 3. Measurement setup.

5.1.4 Deviations from ANSI C63.4

The test site was arranged according to FCC 02-48 with a flat sand bed located in the ground plane.

5.1.5 Environmental conditions

Temperature (inside test facility): 14 to 20 °C

5.1.6 Results

Results are valid for the described arrangement and operation of the tested EUT.

The EUT complied with the requirement of radiated emission specified in FCC 15.509 (d) and IC RSS-220 in the frequency range 30 MHz – 960 MHz. No narrowband signals above the limit line were related to the EUT.

Emission levels measured with peak detector and with the quasi peak limit according to FCC 15.209 and IC RSS-220 are shown in the diagrams below. Emission levels measured with quasi-peak detector at maximized positions are shown in the table below.

Frequency (MHz)	Limit (dB μ V/m)	Quasi peak Result (dB μ V/m)	Margin (dB)	Notes
189	43.5	41.0	2.5	Pass
191	43.5	40.4	3.1	Pass
253	46.0	42.4	3.6	Pass
255	46.0	41.1	4.9	Pass
329	46.0	44.1	1.9	Pass
333	46.0	44.2	1.8	Pass
497	46.0	43.4	2.6	Pass
499	46.0	42.5	3.5	Pass

The EUT also fulfilled the requirements of frequency notching in the FCC Waiver DA 12-41, dated January 11, 2012.



Composite trace of peak emissions. 30 MHz – 960 MHz.

Peak detector, 120 kHz bandwidth.

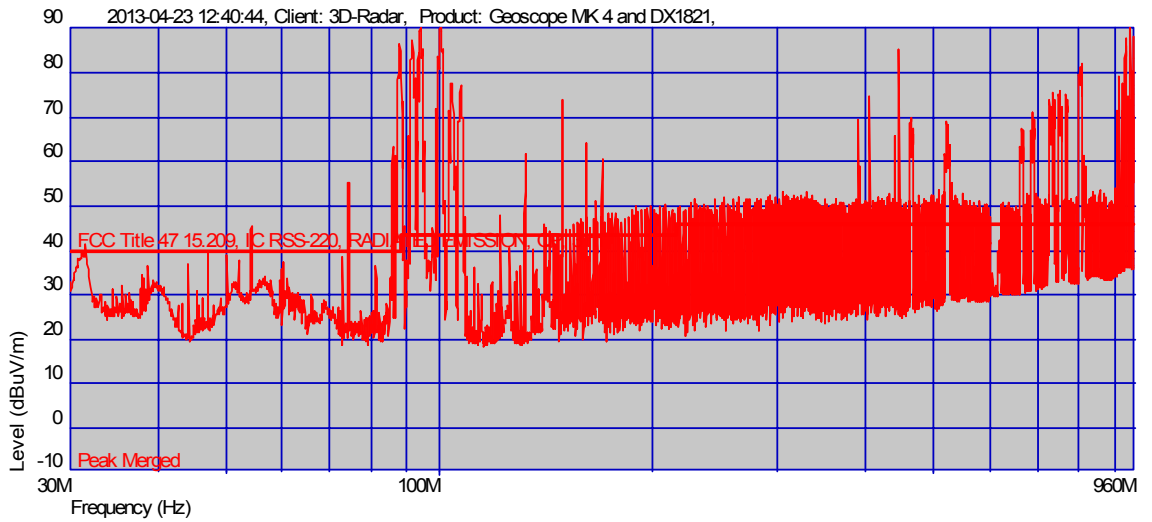

Ambient emission. 30 MHz – 960 MHz.

Peak detector, 120 kHz bandwidth.

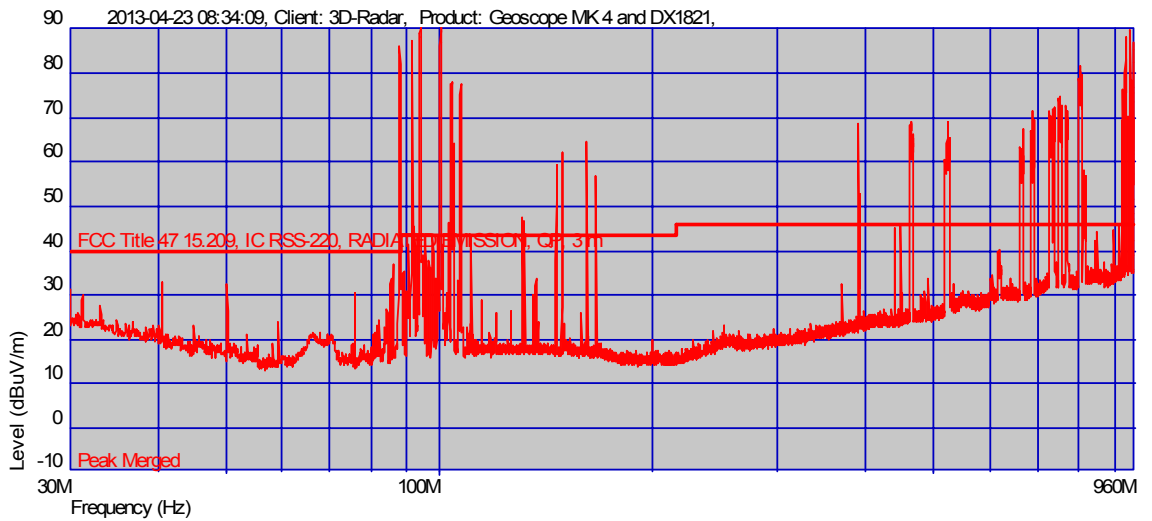

Composite trace of peak emissions. 590 MHz – 630 MHz.

Peak detector, 120 kHz bandwidth.

Diagram showing notch between 600 MHz and 620 MHz. Detected signals in the frequency range 600 MHz and 620 MHz are ambient disturbances.

The requirement in FCC Waiver DA 12-41 is 608 MHz to 614 MHz.

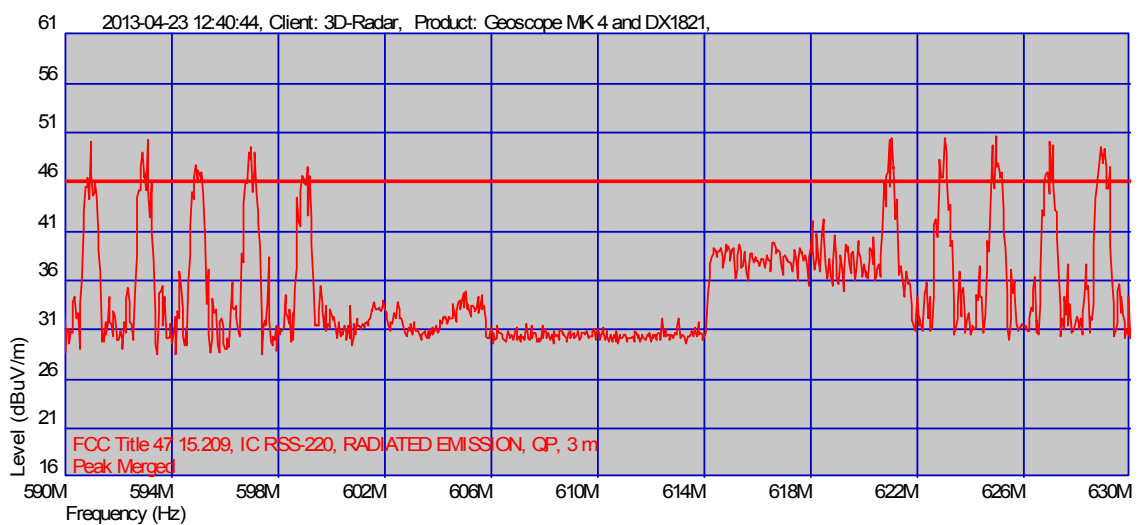

5.1.7 Instrumentation

Manufacturer	Model	Range	S/N	Cal. Interval	Cal. Date
Rohde & Schwarz EMI-receiver	ESU26	20 Hz – 26.5 GHz	100019	24 month	October 2012
Chase Bilog antenna	CBL6111A	30 - 1000 MHz	1831	36 month	February 2012
EMISYS Antenna tower	140K			Not applicable	
Heinrich Diesel Controller	HD100		100/391	Not applicable	

5.2 Measurement of radiated emission, 960 MHz – 18 GHz

5.2.1 Requirements according to FCC 15.509 (d, e) and IC RSS-220

Radiated emission from the EUT shall not exceed the limit as specified below. Measurements are performed up to 18 GHz, which include the 10th harmonic of the center UWB frequency, see 5.3.5.

Frequency range	Limit	Limit*	Limit**
960 – 1610 MHz	-65.3 dBm EIRP	29.9 dB μ V/m	39.4 dB μ V/m
1610 – 1990 MHz	-53.3 dBm EIRP	41.9 dB μ V/m	51.4 dB μ V/m
1990 – 3100 MHz	-51.3 dBm EIRP	43.9 dB μ V/m	53.4 dB μ V/m
3100 – 10600 MHz	-41.3 dBm EIRP	53.9 dB μ V/m	63.4 dB μ V/m
> 10600 MHz	-51.3 dBm EIRP	43.9 dB μ V/m	53.4 dB μ V/m

Frequency range	Limit	Limit*	Limit**
1164 – 1240 MHz	-75.3 dBm EIRP	19.9 dB μ V/m	29.4 dB μ V/m
1559 – 1610 MHz	-75.3 dBm EIRP	19.9 dB μ V/m	29.4 dB μ V/m

* Converted to field strength level at 3 meters according to FCC 15.521 (g)

** Converted to field strength level at 1 m according to $E_{1m} = E_{3m} + 9.5$ dB μ V/m

5.2.2 Requirements according to FCC Waiver DA 12-41, dated January 11, 2012

The radar device shall implement frequency notching to avoid placing intentional transmissions in the following frequency bands:

- 1400 MHz – 1427 MHz
- 1660.5 MHz – 1668.4 MHz
- 2690 MHz – 2700 MHz

5.2.3 Procedures

Radiated emission was measured on an Open Area Test Site (OATS) with 1 m measuring distance between the EUT and the measurement antenna, see Picture 4. The antenna height was fixed at 1 m and the antenna was slightly tilted and pointed towards the EUT.

The emission was measured with an RMS detector in the frequency range 960 MHz to 18 GHz. The number of sweep points for the whole frequency range was 34 080 and the total sweep time was 34 s. Thus the dwell time was 1 ms.

The following resolution bandwidths, video bandwidths and sweep times were used during the measurements.

Frequency range	RBW	VBW	Sweep points	Total sweep time
960 MHz – 18 GHz	1 MHz	5 MHz	34 080	34 s
1164 MHz – 1240 MHz	1 kHz	5 MHz	152 000	152 s
1559 MHz – 1610 MHz	1 kHz	5 MHz	102 000	102 s



Picture 4. Measurement setup.

Measurements were performed with the EUT rotated in 16 different positions on the sand bed and with two antenna polarizations resulting in a total of 32 sweeps.

Measurement software was used to add antenna factors and cable attenuation and the resulting maximum field strength level were plotted.

After the sweeps field strength levels above the limit were checked manually due to the high number of ambient signals.

5.2.4 Environmental conditions

Temperature (inside test facility): 14 to 20 °C

5.2.5 Results

Results are valid for the described arrangement and operation of the tested EUT.

The EUT complied with the requirement of radiated emission specified in FCC 15.509 (d) and (e) and IC RSS-220 (6.2.1) in the frequency range 960 MHz – 18 GHz. Emissions above the limit were not related to the EUT.

The EUT also fulfilled the requirements of frequency notching in the FCC Waiver DA 12-41, dated January 11, 2012.

Measured emission levels are shown in the diagrams below. Results are also tabulated including the highest peaks, where peaks were found, originating from the EUT.

960 MHz – 18 GHz. RMS detector, 1 MHz bandwidth.

Frequency (GHz)	Limit * (dBμV/m)	RMS level (dBμV/m)	Margin (dB)	Notes
0.97	39.4	37.6	1.8	PASS
1.01	39.4	36.4	3.0	PASS
1.09	39.4	37.0	2.4	PASS
1.26	39.4	36.6	2.8	PASS
1.36	39.4	37.0	2.4	PASS
1.47	39.4	37.4	2.0	PASS

* Converted to field strength limit at 1 m according to $E_{1m} = E_{3m} + 9.5 \text{ dB}\mu\text{V/m}$



1164 MHz – 1240 MHz. RMS detector, 1 kHz bandwidth.

Frequency (MHz)	Limit * (dB μ V/m)	RMS level (dB μ V/m)	Margin (dB)	Notes
1191	29.4	12.1	17.3	PASS
1200	29.4	18.5	10.9	PASS

* Converted to field strength limit at 1 m according to $E_{1m} = E_{3m} + 9.5$ dB μ V/m

1559 MHz – 1610 MHz. RMS detector, 1 kHz bandwidth.

Frequency (MHz)	Limit * (dB μ V/m)	RMS level (dB μ V/m)	Margin (dB)	Notes
1562	29.4	25.9	3.5	PASS
1607	29.4	8.2	21.2	PASS

* Converted to field strength limit at 1 m according to $E_{1m} = E_{3m} + 9.5$ dB μ V/m

Composite trace of peak emissions. 960 MHz – 18 GHz.

RMS detector, 1 MHz bandwidth.

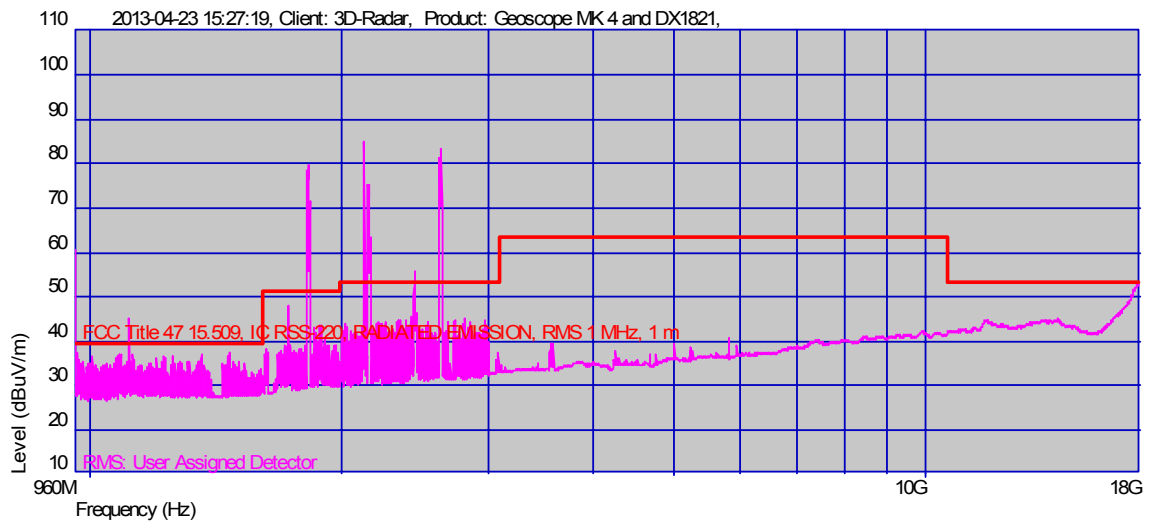

Comment: Signals exceeding the limit line were investigated and found to be ambient signals.

Ambient emissions. 960 MHz – 18 GHz.

RMS detector, 1 MHz bandwidth.

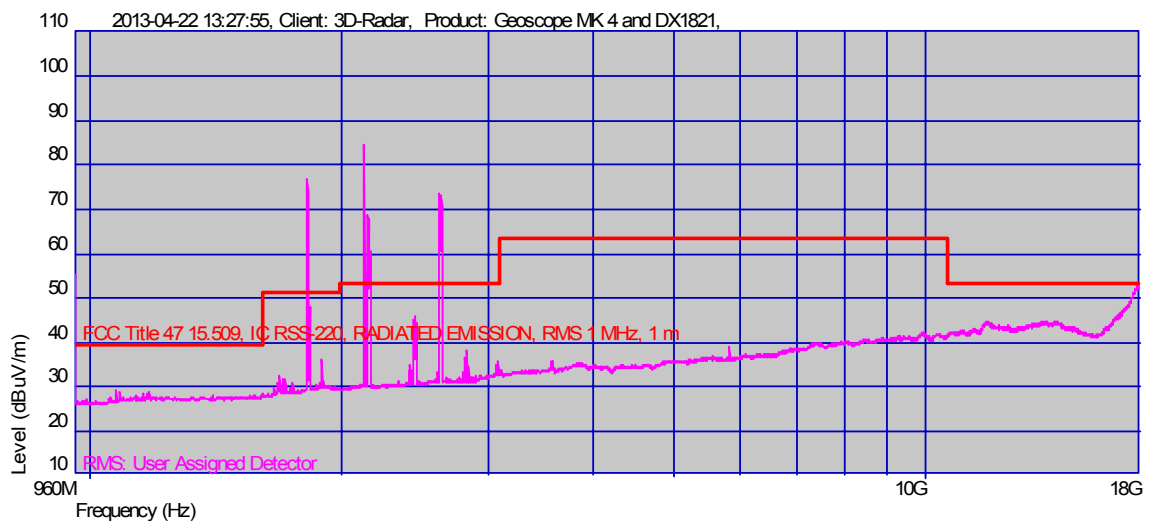

Composite trace of emissions. 1164 MHz – 1240 MHz.

RMS detector, 1 kHz bandwidth.

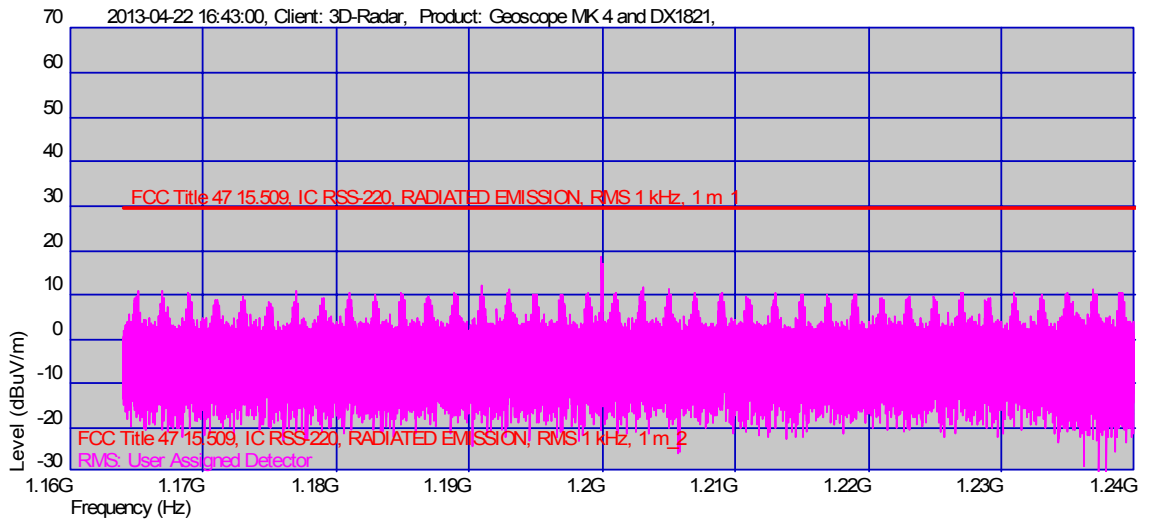

Ambient emissions. 1164 MHz – 1240 MHz.

RMS detector, 1 kHz bandwidth.

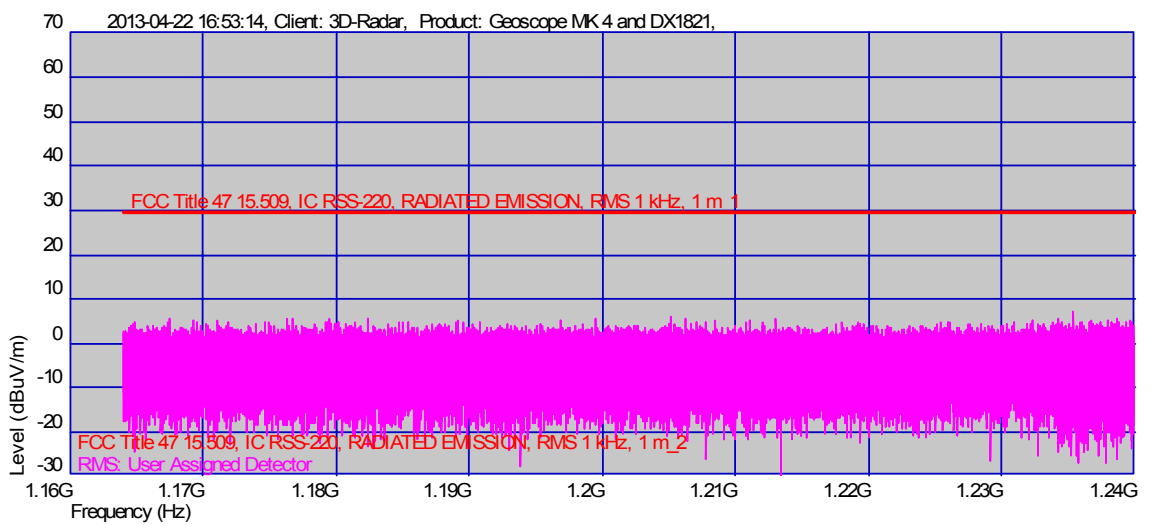

Composite trace of emissions. 1559 MHz – 1610 MHz.

RMS detector, 1 kHz bandwidth.

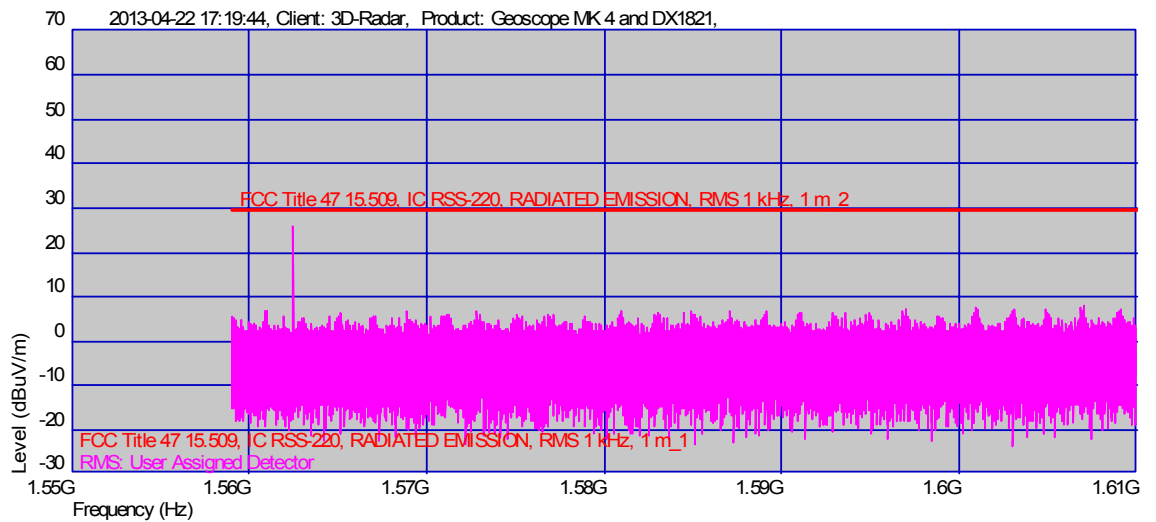

Ambient emissions. 1559 MHz – 1610 MHz.

RMS detector, 1 kHz bandwidth.

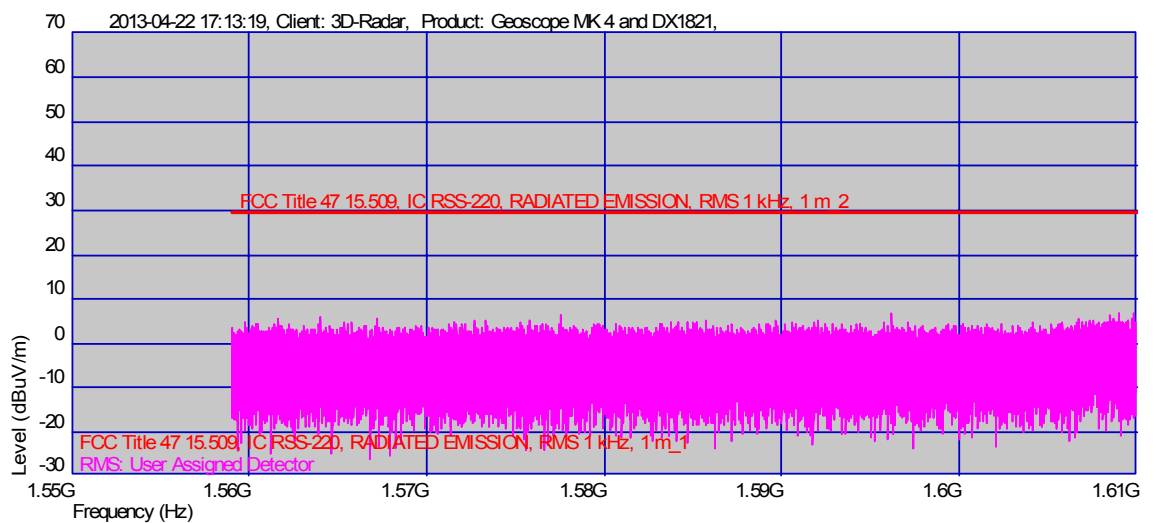

Composite trace of emissions. 1400 MHz – 1427 MHz.

RMS detector, 1 MHz bandwidth.

Diagram showing notch between 1400 MHz and 1440 MHz. Detected signals in between that range are ambient disturbances.

The requirement in FCC Waiver DA 12-41 is 1400 MHz to 1427 MHz.

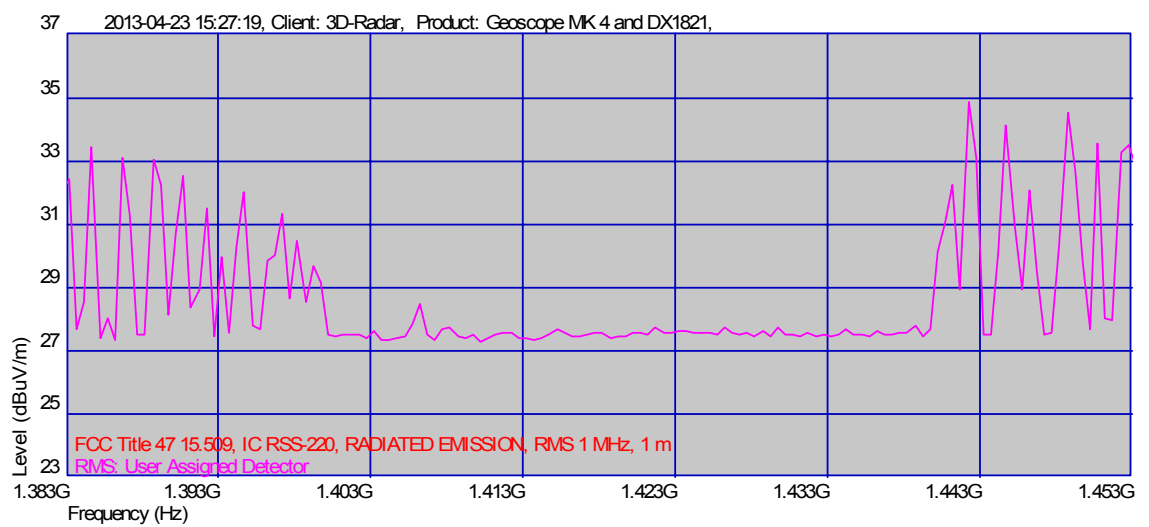

Composite trace of emissions. 1660.5 MHz – 1668.4 MHz.

RMS detector, 1 MHz bandwidth.

Diagram showing notch between 1640 MHz and 1680 MHz. Detected signals in between that range are ambient disturbances.

The requirement in FCC Waiver DA 12-41 is 1660.5 MHz to 1668.4 MHz.

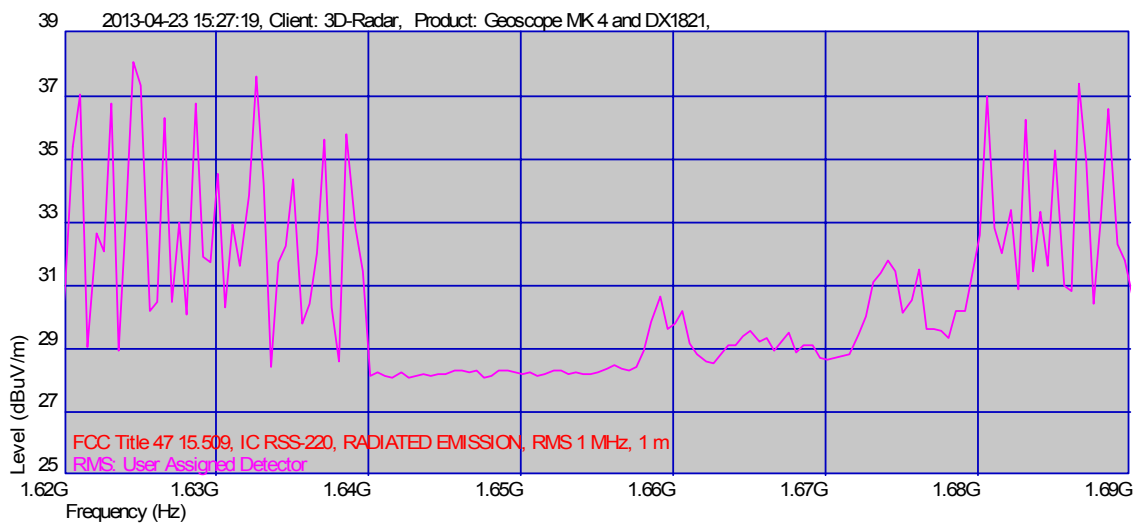

Composite trace of emissions. 2690 MHz – 2700 MHz.

RMS detector, 1 MHz bandwidth.

Diagram showing notch between 2680 MHz and 2719 MHz. Detected signals in between that range are ambient disturbances.

The requirement in FCC Waiver DA 12-41 is 2690 MHz to 2700 MHz.

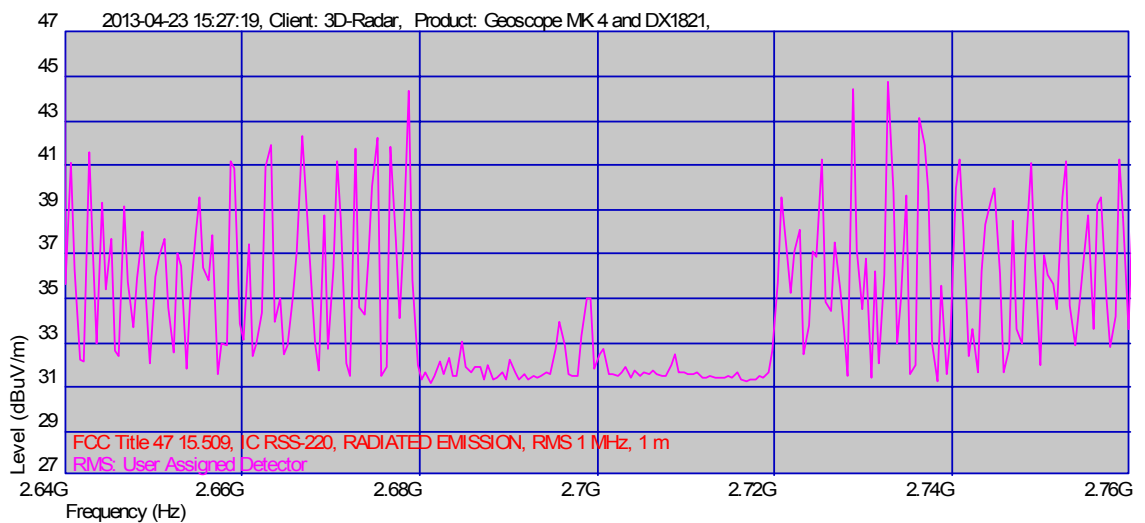

5.2.6 Instrumentation

Manufacturer	Model	Range	S/N	Cal. Interval	Cal. Date
Rohde & Schwarz EMI-receiver	ESU26	20 Hz – 26.5 GHz	100019	24 month	October 2012
Miteq Pre-amplifier	AFS44- 00101800-25-10P-44	100 MHz – 18 GHz	1127	12 month	December 2012
Huber/Suhner Attenuator	6806.19A	0 Hz – 18 GHz	1115	12 month	July 2012
Emco Double Ridge Waveguide	3115	0.96 GHz - 18 GHz	2800	36 month	November 2011

5.3 Measurement of UWB bandwidth and peak emissions

5.3.1 Requirements and definitions according to FCC and IC

5.3.1.1 Definitions according to FCC 15.503 (d) and IC RSS-220

UWB bandwidth: The frequency band bounded by the points that are 10 dB below the highest radiated emission, as based on the complete transmission system including the antenna. The upper boundary is designated f_H and the lower boundary is designated f_L . The frequency at which the highest radiated emission occurs is designated f_M .

Center frequency (f_C): Equals $(f_H + f_L)/2$.

Fractional bandwidth: Equals $2(f_H - f_L) / (f_H + f_L)$.

Ultra-wideband (UWB) transmitter/device: An intentional radiator that, at any point in time, has a fractional bandwidth equal to or greater than 0.20 or has a UWB bandwidth equal to or greater than 500 MHz, regardless of the fractional bandwidth.

5.3.1.2 Requirements according to FCC 15.509 (a) and IC RSS-220 (6.2.1)

The UWB bandwidth of an imaging system operating under the provisions of this section must be below 10.6 GHz.

5.3.1.3 Requirements according to FCC 15.509 (f) and IC RSS-220 (6.2.1)

For UWB devices where the frequency at which the highest radiated emission occurs, f_M is above 960 MHz, there is a limit on the peak level of the emissions contained within a 50 MHz bandwidth centred on f_M . The limit is 0 dBm EIRP. It is acceptable to employ a different resolution bandwidth and a correspondingly different peak emission limit, following the procedures described in FCC 15.521 and in the Annex of IC RS-220.

5.3.2 Requirements according to FCC Waiver DA 12-41, dated January 11, 2012

Measurements of emissions from the radar device shall be conducted with the stepping function active.

The radar device shall not be sold in any hand-held configurations.

The radar device shall comply with all other technical and operational requirements applicable to UWB GPR devices under Part 15, Subpart F of the Commission's rules.

The device shall operate with stepped frequency modulation in 2 MHz steps between 140 MHz and 3 GHz with a scan/cycle rate of approximately 3 ms. The system may not use any single frequency longer than 2 μ s in any 3 ms period of time.

5.3.3 Procedures

The setup was made so that the EUT antenna was tilted and pointing directly towards the measurement antenna. The measuring distance was 3 m.

To determine the spectrum parameters measurements were performed with peak detector with 1 MHz bandwidth.

If f_M was above 960 MHz, an additional peak detector was used during the measurements described in Section 5.2. Measurements were performed at 1 m distance and with a measurement bandwidth of 1 MHz. The limit (0 dBm EIRP at 3 m and 50 MHz measurement bandwidth) was recalculated according to:

$$E \text{ (dB}\mu\text{V/m)} = 0 + 95.2 + 20\log(1\text{MHz}/50\text{MHz}) + 9.5 = 70.7.$$

Measurement software added antenna factors and cable attenuation.



Picture 5. Measurement setup, 30 MHz – 1 GHz.



Picture 6. Measurement setup, 1 GHz – 4 GHz.

5.3.4 Environmental conditions

Temperature (inside test facility): 14 to 20 °C

5.3.5 Results

Results are valid for the described arrangement and operation of the tested EUT.

The EUT fulfilled the definition of an UWB transmitter according to FCC 15.503 (d) and IC RSS-220. The EUT complied with the requirement in FCC 15.509 (a, f) and IC RSS-220 (6.2.1).

The EUT also fulfils the requirements of pulse parameters in the FCC Waiver DA 12-41, dated January 11, 2012.

The requirements that the radar device not shall be sold in any hand-held configurations, and that the device shall operate with stepped frequency modulation in 2 MHz steps, were confirmed by manufacturer statement, but were not verified by measurements.



UWB definition

Measurement data is presented in diagrams below. From the diagrams data regarding the UWB bandwidth was gathered and calculated.

Frequency of highest emission f_M	770.8 MHz
Lower boundary f_L	286.8 MHz
Upper boundary f_H	1583 MHz
Centre frequency f_C	934.9 MHz
Fractional bandwidth	1.39

Emission at f_M

The frequency of highest emission (f_M) was 770.8 MHz, which is below 960 MHz. Thus, there is no requirement for the emission at f_M measured with peak detector over 50 MHz bandwidth.

Pulse parameters

The pulse parameters were measured with the receiver in zero span at 1301 MHz.

Pulse repetition time	3.4 ms
Pulse length	1.9 μ s

Measurements of UWB bandwidth. 30 MHz – 1 GHz. EUT tilted.

Peak detector, 1 MHz bandwidth.

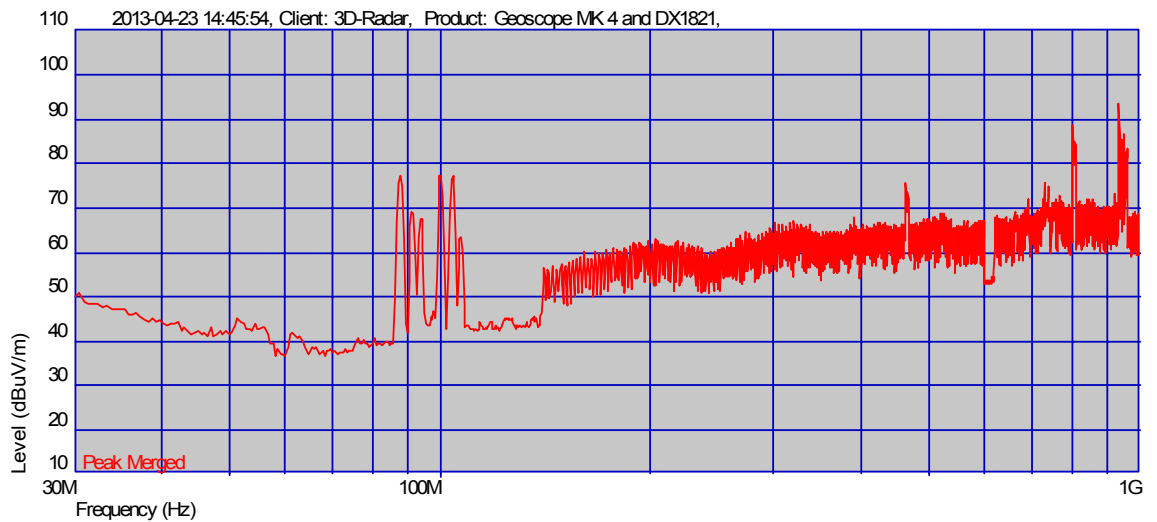
**Measurements of UWB bandwidth. 1 GHz – 4 GHz. EUT tilted.**

Peak detector, 1 MHz bandwidth.

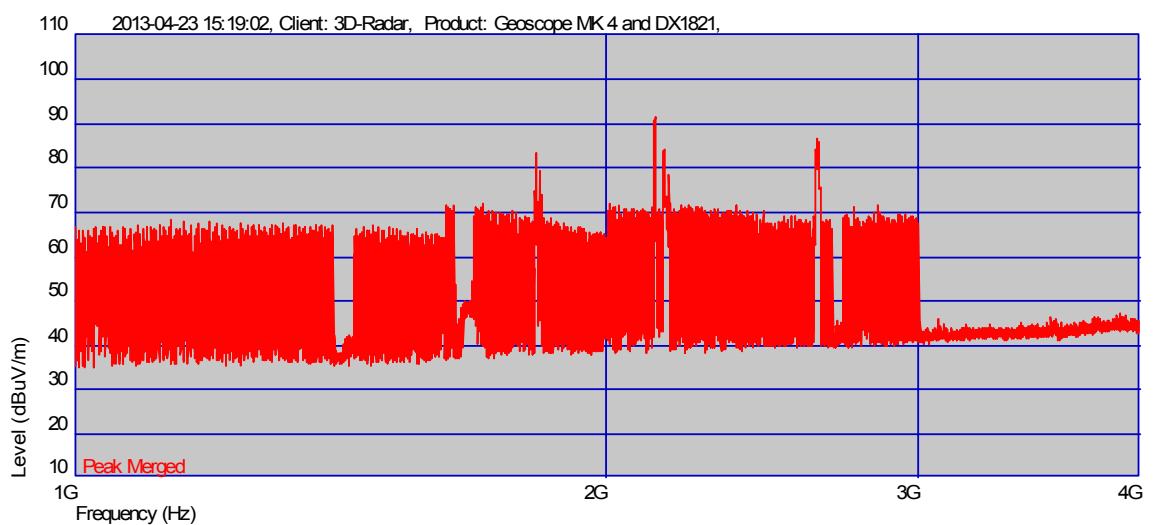

Measurement of pulse repetition time.

Peak detector, 1 MHz bandwidth. Measured with zero span at 1301 MHz.

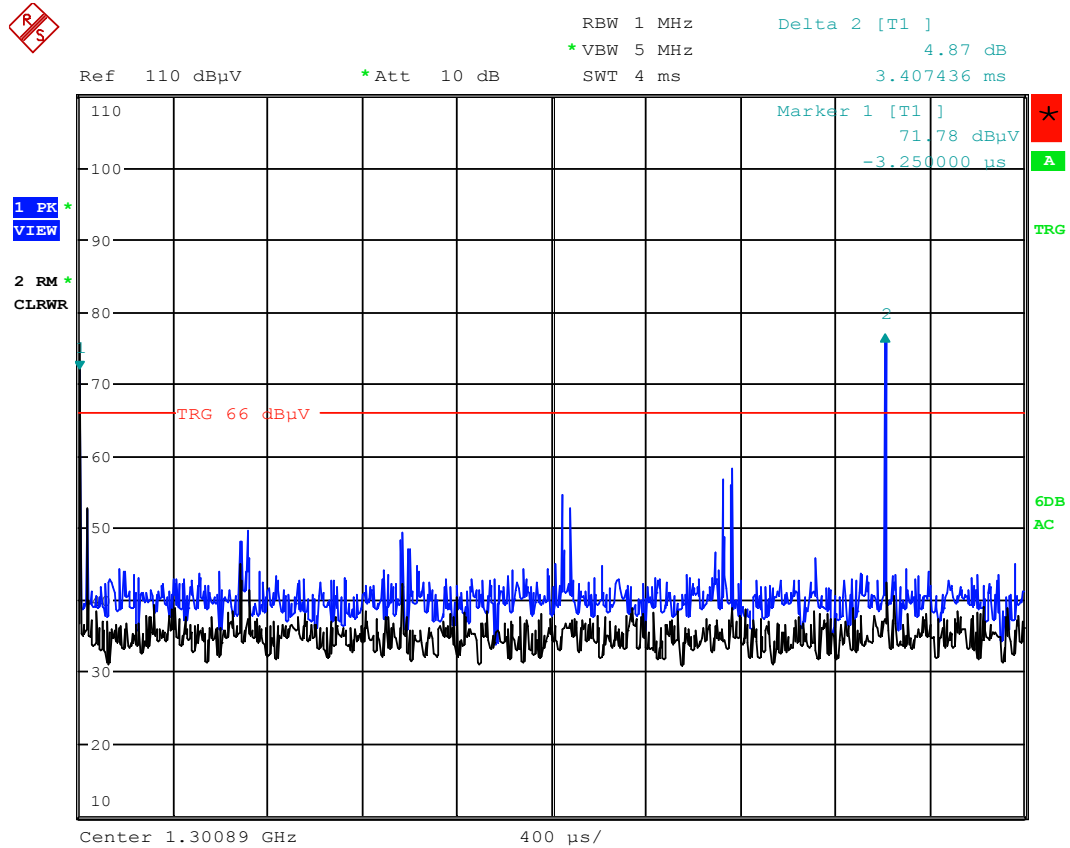

Date: 23.APR.2013 17:54:01

Measurement of pulse length.

Peak detector, 1 MHz bandwidth. Measured with zero span at 1301 MHz.

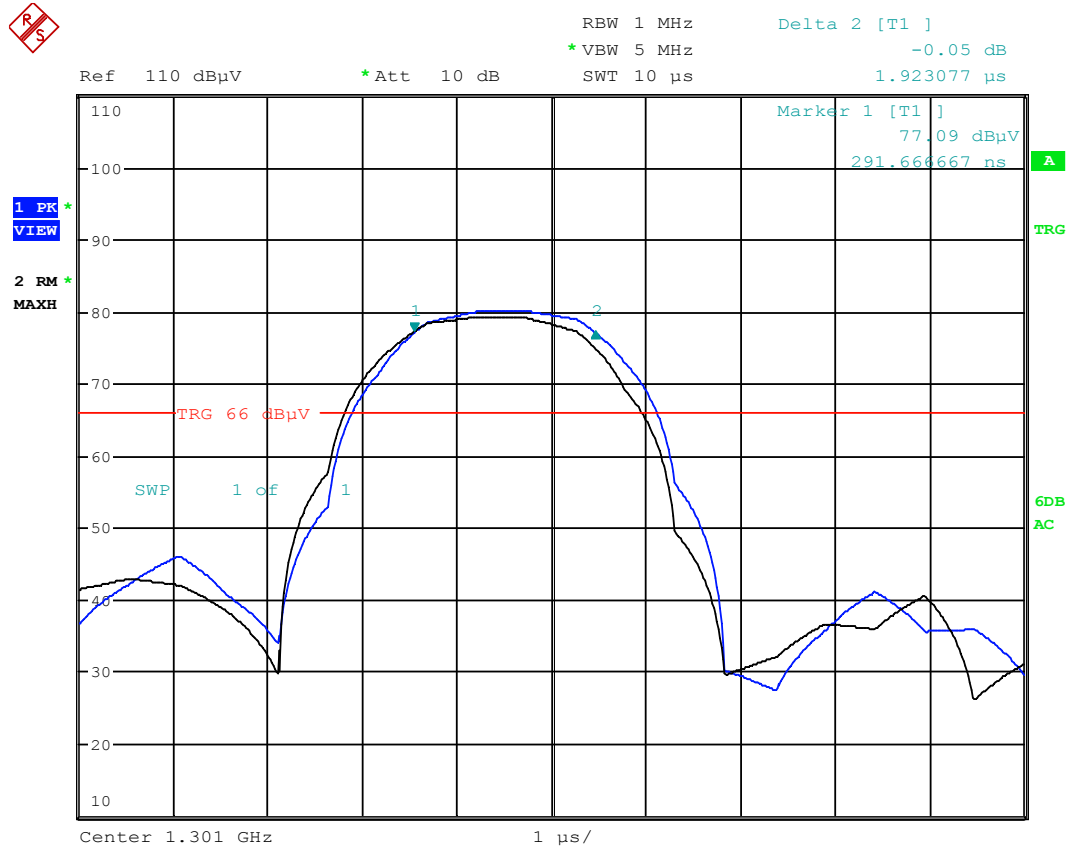

Date: 23.APR.2013 17:49:32

5.3.6 Instrumentation

Manufacturer	Model	Range	S/N	Cal. Interval	Cal. Date
Rohde & Schwarz EMI-receiver	ESU26	20 Hz – 26.5 GHz	100019	24 month	October 2012
Miteq Pre-amplifier	AFS44- 00101800-25-10P-44	100 MHz – 18 GHz	1127	12 month	December 2012
Huber/Suhner Attenuator	6806.19A	0 Hz – 18 GHz	1115	12 month	July 2012
Emco Double Ridge Waveguide	3115	0.96 GHz - 18 GHz	2800	36 month	November 2011
Chase Bilog antenna	CBL6111A	30 - 1000 MHz	1831	36 month	February 2012