

FCC Test Report

(PART 27)

Report No.: RF180301C45

FCC ID: 2AAGMVZM2OQ

Test Model: VZM20Q

Received Date: Mar. 01, 2018

Test Date: Mar. 18, 2018 ~ Mar. 20, 2018

Issued Date: Mar. 28, 2018

Applicant: SEQUANS Communications SA

Address: Batiment CitiCenter 19, le Parvis de la Defense 92073 Paris la Defense
Cedex France

Issued By: Bureau Veritas Consumer Products Services (H.K.) Ltd., Taoyuan Branch

Lab Address: No. 47-2, 14th Ling, Chia Pau Vil., Lin Kou Dist., New Taipei City, Taiwan
(R.O.C)

Test Location: No. 19, Hwa Ya 2nd Rd, Wen Hwa Tsuen, Kwei Shan Hsiang, Taoyuan
Hsien 333, Taiwan, R.O.C.

**FCC Registration /
Designation Number:** 788550 / TW0003



This report is for your exclusive use. Any copying or replication of this report to or for any other person or entity, or use of our name or trademark, is permitted only with our prior written permission. This report sets forth our findings solely with respect to the test samples identified herein. The results set forth in this report are not indicative or representative of the quality or characteristics of the lot from which a test sample was taken or any similar or identical product unless specifically and expressly noted. Our report includes all of the tests requested by you and the results thereof based upon the information that you provided to us. You have 60 days from date of issuance of this report to notify us of any material error or omission caused by our negligence, provided, however, that such notice shall be in writing and shall specifically address the issue you wish to raise. A failure to raise such issue within the prescribed time shall constitute your unqualified acceptance of the completeness of this report, the tests conducted and the correctness of the report contents. Unless specific mention, the uncertainty of measurement has been explicitly taken into account to declare the compliance or non-compliance to the specification. The report must not be used by the client to claim product certification, approval, or endorsement by TAF or any government agency

Table of Contents

Release Control Record	3
1 Certificate of Conformity	4
2 Summary of Test Results	5
2.1 Measurement Uncertainty	5
2.2 Test Site and Instruments	7
3 General Information	9
3.1 General Description of EUT	9
3.2 Configuration of System under Test	10
3.2.1 Description of Support Units	10
3.3 Test Mode Applicability and Tested Channel Detail	10
3.4 EUT Operating Conditions	13
3.5 General Description of Applied Standards	13
4 Test Types and Results	14
4.1 Output Power Measurement	14
4.1.1 Limits of Output Power Measurement	14
4.1.2 Test Procedures	14
4.1.3 Test Setup	15
4.1.4 Test Results	16
4.2 Frequency Stability Measurement	27
4.2.1 Limits of Frequency Stability Measurement	27
4.2.2 Test Procedure	27
4.2.3 Test Setup	27
4.2.4 Test Results	28
4.3 Occupied Bandwidth Measurement	34
4.3.1 Limits of Occupied Bandwidth Measurement	34
4.3.2 Test Procedure	34
4.3.3 Test Setup	34
4.3.4 Test Result	35
4.4 Band Edge Measurement	38
4.4.1 Limits of Band Edge Measurement	38
4.4.2 Test Setup	38
4.4.3 Test Procedures	38
4.4.4 Test Results	39
4.5 Peak to Average Ratio	47
4.5.1 Limits of Peak to Average Ratio Measurement	47
4.5.2 Test Setup	47
4.5.3 Test Procedures	47
4.5.4 Test Results	48
4.6 Conducted Spurious Emissions	51
4.6.1 Limits of Conducted Spurious Emissions Measurement	51
4.6.2 Test Setup	51
4.6.3 Test Procedure	51
4.6.4 Test Results	52
4.7 Radiated Emission Measurement	68
4.7.1 Limits of Radiated Emission Measurement	68
4.7.2 Test Procedure	68
4.7.3 Deviation from Test Standard	68
4.7.4 Test Setup	69
4.7.5 Test Results	70
5 Pictures of Test Arrangements	98
Appendix – Information on the Testing Laboratories	99

Release Control Record

Issue No.	Description	Date Issued
RF180301C45	Original Release	Mar. 28, 2018

1 Certificate of Conformity

Product: VZM20Q EZlinkLTE modules

Brand: SEQUANS

Test Model: VZM20Q

Sample Status: MP

Applicant: SEQUANS Communications SA

Test Date: Mar. 18, 2018 ~ Mar. 20, 2018

Standards: FCC Part 27, Subpart C, L

The above equipment has been tested by **Bureau Veritas Consumer Products Services (H.K.) Ltd., Taoyuan Branch**, and found compliance with the requirement of the above standards. The test record, data evaluation & Equipment Under Test (EUT) configurations represented herein are true and accurate accounts of the measurements of the sample's RF characteristics under the conditions specified in this report.

Prepared by :

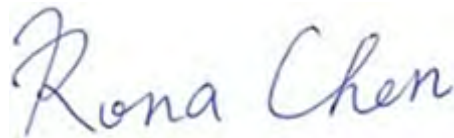

Date:

Mar. 28, 2018

Rona Chen / Specialist

Approved by :



Date:

Mar. 28, 2018

Dylan Chiou / Project Engineer

2 Summary of Test Results

Applied Standard: FCC Part 27 & Part 2 (LTE 4)			
FCC Clause	Test Item	Result	Remarks
2.1046 27.50(d)(4)	Maximum Peak Output Power	Pass	Meet the requirement of limit.
2.1055 27.54	Frequency Stability	Pass	Meet the requirement of limit.
2.1049 27.53(h)	Occupied Bandwidth	Pass	Meet the requirement of limit.
27.50(d)(5)	Peak to Average Ratio	Pass	Meet the requirement of limit.
27.53(h)	Band Edge Measurements	Pass	Meet the requirement of limit.
2.1051 27.53(h)	Conducted Spurious Emissions	Pass	Meet the requirement of limit.
2.1053 27.53(h)	Radiated Spurious Emissions	Pass	Meet the requirement of limit. Minimum passing margin is -33.22 dB at 39.70 MHz.

Applied Standard: FCC Part 27 & Part 2 (LTE 13)			
FCC Clause	Test Item	Result	Remarks
2.1046 27.50(b)(10)	Maximum Peak Output Power	Pass	Meet the requirement of limit.
2.1055 27.54	Frequency Stability	Pass	Meet the requirement of limit.
2.1049 27.53(g)	Occupied Bandwidth	Pass	Meet the requirement of limit.
27.50(d)(5)	Peak to Average Ratio	Pass	Meet the requirement of limit.
27.53(g)	Band Edge Measurements	Pass	Meet the requirement of limit.
2.1051 27.53(g)	Conducted Spurious Emissions	Pass	Meet the requirement of limit.
2.1053 27.53(g)(f)	Radiated Spurious Emissions	Pass	Meet the requirement of limit. Minimum passing margin is -2.52 dB at 1564.00 MHz.

2.1 Measurement Uncertainty

Where relevant, the following measurement uncertainty levels have been estimated for tests performed on the EUT as specified in CISPR 16-4-2:

Measurement	Frequency	Expanded Uncertainty (k=2) (±)
Conducted Emissions at mains ports	150 kHz ~ 30 MHz	2.44 dB
Radiated Emissions up to 1 GHz	30 MHz ~ 200 MHz	2.93 dB
	200 MHz ~ 1000 MHz	2.95 dB
Radiated Emissions above 1 GHz	1 GHz ~ 18 GHz	2.26 dB
	18 GHz ~ 40 GHz	1.94 dB

2.2 Test Site and Instruments

Description & Manufacturer	Model No.	Serial No.	Date of Calibration	Due Date of Calibration
Test Receiver Agilent	N9038A	MY52260177	Jul. 05, 2017	Jul. 04, 2018
Spectrum Analyzer Agilent	N9010A	MY52220314	Nov. 24, 2017	Nov. 23, 2018
Spectrum Analyzer ROHDE & SCHWARZ	FSU43	100115	Nov. 23, 2017	Nov. 22, 2018
BILOG Antenna SCHWARZBECK	VULB 9168	9168-153	Dec. 06, 2017	Dec. 05, 2018
Double Ridge Guide Horn Antenna EMCO	3115	5619	Nov. 30, 2017	Nov. 29, 2018
BILOG Antenna SCHWARZBECK	VULB 9168	9168-153	Dec. 06, 2017	Dec. 05, 2018
RF signal cable ETS-LINDGREN	5D-FB	Cable-CH1-01(RFC -SMS-100-SMS-12 0+RFC-SMS-100-S MS-400)	Jun. 23, 2017	Jun. 22, 2018
Fixed Attenuator Mini-Circuits	MDCS18N-10	MDCS18N-10-01	Apr. 17, 2017	Apr. 16, 2018
MXG Vector signal generator Agilent	N5182B	MY53050430	Oct. 24, 2017	Oct. 23, 2018
Preamplifier EMCI	EMC 012645	980115	Oct. 20, 2017	Oct. 19, 2018
Preamplifier EMCI	EMC 184045	980116	Oct. 20, 2017	Oct. 19, 2018
Preamplifier EMCI	EMC 330H	980112	Oct. 13, 2017	Oct. 12, 2018
Power Meter Anritsu	ML2495A	1012010	Aug. 15, 2017	Aug. 14, 2018
Power Sensor Anritsu	MA2411B	1315050	Aug. 15, 2017	Aug. 14, 2018
RF Coaxial Cable HUBER+SUHNNER	EMC104-SM-SM-800 0&3000	140811+170717	Oct. 20, 2017	Oct. 19, 2018
RF Coaxial Cable HUBER+SUHNNER	SUCOFLEX 104	EMC104-SM-SM-1 000(140807)	Oct. 20, 2017	Oct. 19, 2018
RF Coaxial Cable Worken	8D-FB	Cable-Ch10-01	Oct. 20, 2017	Oct. 19, 2018
Boresight Antenna Fixture	FBA-01	FBA-SIP01	NA	NA
Software BV ADT	E3 6.120103	NA	NA	NA
Antenna Tower MF	MFA-440H	NA	NA	NA
Turn Table MF	MFT-201SS	NA	NA	NA
Antenna Tower & Turn Table Controller MF	MF-7802	NA	NA	NA
Radio Communication Analyzer	MT8820C	6201300640	Aug. 16, 2017	Aug. 15, 2019
Temperature & Humidity Chamber	GTH-120-40-CP-AR	MAA1306-019	Sep. 08, 2017	Sep. 07, 2018
DC Power Supply Topward	33010D	807748	Oct. 25, 2016	Oct. 24, 2018
Digital Multimeter Fluke	87-III	70360742	Jun. 30, 2017	Jun. 29, 2018

- Note:
1. The calibration interval of the above test instruments is 12 / 24 months and the calibrations are traceable to NML/ROC and NIST/USA.
 2. The test was performed in HwaYa Chamber 10.
 3. The horn antenna and preamplifier (model: EMC 184045) are used only for the measurement of emission frequency above 1 GHz if tested.
 4. The IC Site Registration No. is IC7450F-10.

3 General Information

3.1 General Description of EUT

Product	VZM20Q EZlinkLTE modules	
Brand	SEQUANS	
Test Model	VZM20Q	
Status of EUT	MP	
Power Supply Rating	5.0 Vdc (Adapter)	
Modulation Type	LTE	QPSK, 16QAM
Frequency Range	LTE Band 4 (Channel Bandwidth: 5 MHz)	1712.5 ~ 1752.5 MHz
	LTE Band 4 (Channel Bandwidth: 10 MHz)	1715.0 ~ 1750.0 MHz
	LTE Band 4 (Channel Bandwidth: 15 MHz)	1717.5 ~ 1747.5 MHz
	LTE Band 4 (Channel Bandwidth: 20 MHz)	1720.0 ~ 1745.0 MHz
	LTE Band 13 (Channel Bandwidth: 5 MHz)	779.5 ~ 784.5 MHz
	LTE Band 13 (Channel Bandwidth: 10 MHz)	782.0 MHz
Emission Designator	LTE Band 4 (Channel Bandwidth: 5 MHz)	1M09G7D
	LTE Band 4 (Channel Bandwidth: 10 MHz)	1M09G7D
	LTE Band 4 (Channel Bandwidth: 15 MHz)	1M10G7D
	LTE Band 4 (Channel Bandwidth: 20 MHz)	1M09G7D
	LTE Band 13 (Channel Bandwidth: 5 MHz)	1M09G7D
	LTE Band 13 (Channel Bandwidth: 10 MHz)	1M09G7D
Max. ERP Power	LTE Band 13 (Channel Bandwidth: 5 MHz)	158.85 mW
	LTE Band 13 (Channel Bandwidth: 10 MHz)	151.01 mW
Max. EIRP Power	LTE Band 4 (Channel Bandwidth: 5 MHz)	261.22 mW
	LTE Band 4 (Channel Bandwidth: 10 MHz)	316.96 mW
	LTE Band 4 (Channel Bandwidth: 15 MHz)	337.29 mW
	LTE Band 4 (Channel Bandwidth: 20 MHz)	341.98 mW
Antenna Type	Fixed Internal Antenna	
Accessory Device	Refer to Note as below	
Data Cable Supplied	Refer to Note as below	

Note:

1. The above EUT information is declared by manufacturer and for more detailed features description, please refer to the manufacturer's specifications or user's manual.

3.2 Configuration of System under Test

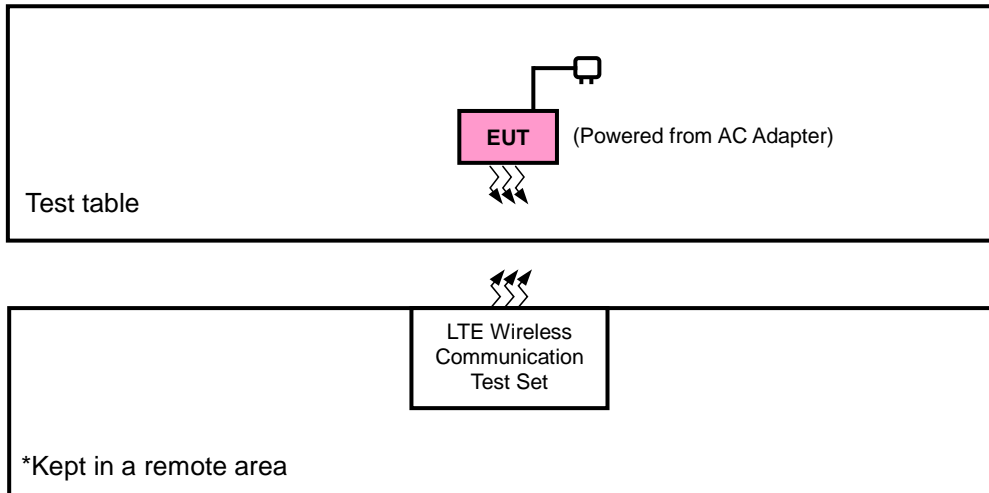

3.2.1 Description of Support Units

The EUT has been tested as an independent unit together with other necessary accessories or support units. The following support units or accessories were used to form a representative test configuration during the tests.

No.	Product	Brand	Model No.	Serial No.	FCC ID
1.	LTE Wireless Communication Test Set	Keysight	E7515A	MY56030229	N/A

No.	Signal Cable Description Of The Above Support Units
1.	N/A

Note:

1. All power cords of the above support units are non-shielded (1.8m).
2. Items 1 acted as communication partners to transfer data.

3.3 Test Mode Applicability and Tested Channel Detail

Pre-Scan has been conducted to determine the worst-case mode from all possible combinations between available modulations, data rates, XYZ axis, and antenna ports

The worst case was found when positioned as the table below. Following channel(s) was (were) selected for the final test as listed below:

Band	ERP / EIRP	Radiated Emission
LTE Band 4	Z-plane	Z-axis
LTE Band 13	Z-plane	Z-axis

LTE Band 4

EUT Configure Mode	Test Item	Available Channel	Tested Channel	Channel Bandwidth	Modulation	Mode		
-	EIRP	19975 to 20375	19975, 20175, 20375	5 MHz	QPSK, 16QAM	1 RB / 0 RB Offset		
		20000 to 20350	20000, 20175, 20350	10 MHz	QPSK, 16QAM	1 RB / 0 RB Offset		
		20025 to 20325	20025, 20175, 20325	15 MHz	QPSK, 16QAM	1 RB / 0 RB Offset		
		20050 to 20300	20050, 20175, 20300	20 MHz	QPSK, 16QAM	1 RB / 0 RB Offset		
-	Frequency Stability	19975 to 20375	19975, 20375	5 MHz	QPSK	1 RB / 24 RB Offset		
		20000 to 20350	20000, 20350	10 MHz	QPSK	1 RB / 49 RB Offset		
		20025 to 20325	20025, 20325	15 MHz	QPSK	1 RB / 74 RB Offset		
		20050 to 20300	20050, 20300	20 MHz	QPSK	1 RB / 99 RB Offset		
-	Occupied Bandwidth	19975 to 20375	19975, 20175, 20375	5 MHz	QPSK, 16QAM	25 RB / 0 RB Offset		
		20000 to 20350	20000, 20175, 20350	10 MHz	QPSK, 16QAM	50 RB / 0 RB Offset		
		20025 to 20325	20025, 20175, 20325	15 MHz	QPSK, 16QAM	75 RB / 0 RB Offset		
		20050 to 20300	20050, 20175, 20300	20 MHz	QPSK, 16QAM	100 RB / 0 RB Offset		
-	Peak to Average Ratio	19975 to 20375	19975, 20175, 20375	5 MHz	QPSK, 16QAM	12 RB / 0 RB Offset		
		20000 to 20350	20000, 20175, 20350	10 MHz	QPSK, 16QAM	1 RB / 24 RB Offset		
		20025 to 20325	20025, 20175, 20325	15 MHz	QPSK, 16QAM	36 RB / 0 RB Offset		
		20050 to 20300	20050, 20175, 20300	20 MHz	QPSK, 16QAM	50 RB / 0 RB Offset		
-	Band Edge	19975 to 20375	19975	5 MHz	QPSK	1 RB / 0 RB Offset 25 RB / 0 RB Offset		
			20375	5 MHz	QPSK	1 RB / 24 RB Offset 25 RB / 0 RB Offset		
		20000 to 20350	20000	10 MHz	QPSK	1 RB / 0 RB Offset 50 RB / 0 RB Offset		
			20350	10 MHz	QPSK	1 RB / 49 RB Offset 50 RB / 0 RB Offset		
		20025 to 20325	20025	15 MHz	QPSK	1 RB / 0 RB Offset 75 RB / 0 RB Offset		
			20325	15 MHz	QPSK	1 RB / 74 RB Offset 75 RB / 0 RB Offset		
		20050 to 20300	20050	20 MHz	QPSK	1 RB / 0 RB Offset 100 RB / 0 RB Offset		
			20300	20 MHz	QPSK	1 RB / 99 RB Offset 100 RB / 0 RB Offset		
		-	Conducted Emission	19975 to 20375	19975, 20175, 20375	5 MHz	QPSK	12 RB / 0 RB Offset
				20000 to 20350	20000, 20175, 20350	10 MHz	QPSK	50 RB / 0 RB Offset
				20025 to 20325	20025, 20175, 20325	15 MHz	QPSK	36 RB / 0 RB Offset
				20050 to 20300	20050, 20175, 20300	20 MHz	QPSK	50 RB / 0 RB Offset
-	Radiated Emission	19975 to 20375	19975, 20175, 20375	5 MHz	QPSK	1 RB / 0 RB Offset		
		20050 to 20300	20050, 20175, 20300	20 MHz	QPSK	1 RB / 0 RB Offset		

Note: This device was tested under all bandwidths, RB configurations and modulations. The worst case was found in QPSK modulation.

LTE Band 13

EUT Configure Mode	Test Item	Available Channel	Tested Channel	Channel Bandwidth	Modulation	Mode
-	ERP	23205 to 23255	23205, 23230, 23255	5 MHz	QPSK, 16QAM	1 RB / 0 RB Offset
					QPSK	6 RB / 0 RB Offset
					16QAM	5 RB / 0 RB Offset
		23230	23230	10 MHz	QPSK, 16QAM	1 RB / 0 RB Offset
					QPSK	6 RB / 0 RB Offset
					16QAM	5 RB / 0 RB Offset
-	Frequency Stability	23205 to 23255	23205, 23255	5 MHz	QPSK	1 RB / 0 RB Offset
		23230	23230	10 MHz	QPSK	1 RB / 24 RB Offset
-	Occupied Bandwidth	23205 to 23255	23205, 23230, 23255	5 MHz	QPSK, 16QAM	25 RB / 0 RB Offset
		23230	23230	10 MHz	QPSK, 16QAM	50 RB / 0 RB Offset
-	Peak to Average Ratio	23205 to 23255	23205, 23230, 23255	5 MHz	QPSK, 16QAM	1 RB / 0 RB Offset
		23230	23230	10 MHz	QPSK, 16QAM	1 RB / 0 RB Offset
-	Band Edge	23205 to 23255	23205	5 MHz	QPSK	1 RB / 0 RB Offset
			23255	5 MHz	QPSK	25 RB / 0 RB Offset
		23230	23230	10 MHz	QPSK	1 RB / 24 RB Offset
			23230	10 MHz	QPSK	25 RB / 0 RB Offset
			23230	10 MHz	QPSK	1 RB / 0 RB Offset
			23230	10 MHz	QPSK	50 RB / 0 RB Offset
-	Conducted Emission	23205 to 23255	23205, 23230, 23255	5 MHz	QPSK	1 RB / 0 RB Offset
		23230	23230	10 MHz	QPSK	1 RB / 0 RB Offset
-	Radiated Emission	23205 to 23255	23205, 23230, 23255	5 MHz	QPSK	1 RB / 0 RB Offset
						6 RB / 0 RB Offset
		23230	23230	10 MHz	QPSK	1 RB / 0 RB Offset
						6 RB / 0 RB Offset

Note: This device was tested under all bandwidths, RB configurations and modulations. The worst case was found in QPSK modulation.

Test Condition:

Test Item	Environmental Conditions	Input Power	Tested By
ERP / EIRP	25 deg. C, 65 % RH	3.8 Vdc	Carlos Chen
Frequency Stability	25 deg. C, 65 % RH	3.8 Vdc	Carlos Chen
Occupied Bandwidth	25 deg. C, 65 % RH	3.8 Vdc	Carlos Chen
Band Edge	25 deg. C, 65 % RH	3.8 Vdc	Carlos Chen
Peak to Average Ratio	25 deg. C, 65 % RH	3.8 Vdc	Carlos Chen
Conducted Emission	25 deg. C, 65 % RH	3.8 Vdc	Carlos Chen
Radiated Emission	25 deg. C, 65 % RH	120 Vac, 60 Hz	Jisyong Wang

3.4 EUT Operating Conditions

The EUT makes a call to the communication simulator. The communication simulator station system controlled a EUT to export maximum output power under transmission mode and specific channel frequency

3.5 General Description of Applied Standards

The EUT is a RF Product. According to the specifications of the manufacturer, it must comply with the requirements of the following standards:

FCC 47 CFR Part 2

FCC 47 CFR Part 27

KDB 971168 D01 Power Meas License Digital Systems v02r02

ANSI/TIA/EIA-603-E 2016

ANSI 63.26-2015

Note: All test items have been performed and recorded as per the above standards.

4 Test Types and Results

4.1 Output Power Measurement

4.1.1 Limits of Output Power Measurement

Fixed, mobile, and portable (hand-held) stations operating in the 1710–1755 MHz band are limited to 1 watt EIRP.

Portable stations (hand-held devices) operating in the 776-787 MHz band are limited to 3 watts ERP

4.1.2 Test Procedures

EIRP / ERP Measurement:

- a. All measurements were done at low, middle and high operational frequency range. RBW and VBW is 5 MHz for WCDMA and 10 MHz for LTE mode.
- b. Substitution method is used for E.I.R.P measurement. In the semi-anechoic chamber, EUT placed on the 0.8 m (below or equal 1 GHz) and/or 1.5 m (above 1 GHz) height of Turn Table, rotated the table around 360 degrees to search the maximum radiation power and receiver antenna shall be rotated vertical and horizontal polarization and moved height from 1 m to 4 m to find the maximum polar radiated power. The “Read Value” is the spectrum reading the maximum power value.
- c. The substitution horn antenna is substituted for EUT at the same position and signals generator export the CW signal to the substitution antenna via a tx cable. Rotated the Turn Table and moved receiving antenna to find the maximum radiation power. Adjust output power level of S.G to get a Value of spectrum reading equal to “Read Value” of step b. Record the power level of S.G.
- d. $EIRP = \text{Output power level of S.G} - \text{TX cable loss} + \text{Antenna gain of substitution horn}$. E.R.P power can be calculated form E.I.R.P power by subtracting the gain of dipole, $E.R.P \text{ power} = E.I.P.R \text{ power} - 2.15 \text{ dBi}$.

Conducted Power Measurement:

- a. The EUT was set up for the maximum power with LTE link data modulation and link up with simulator.
- b. Set the EUT to transmit under low, middle and high channel and record the power level shown on simulator.

4.1.3 Test Setup

EIRP / ERP Measurement:

<Radiated Emission below or equal 1 GHz>

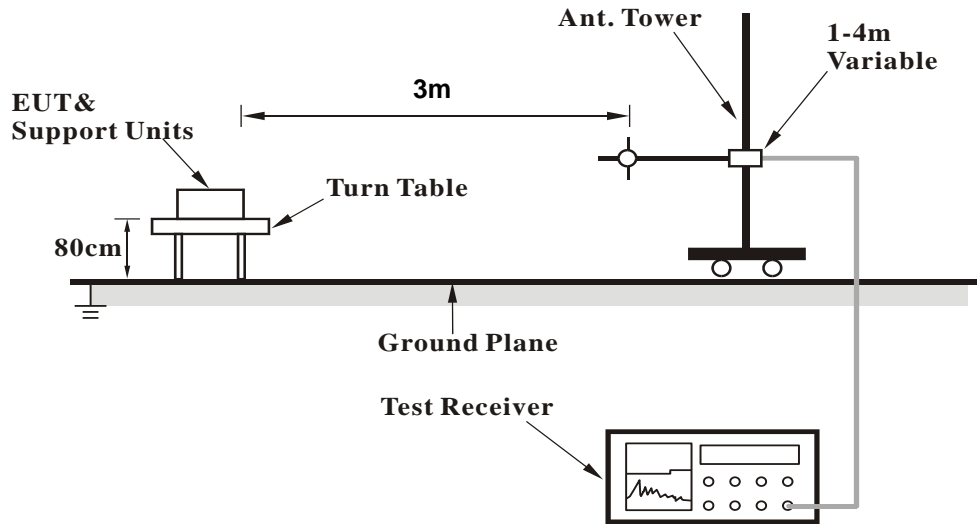

<Radiated Emission above 1 GHz>

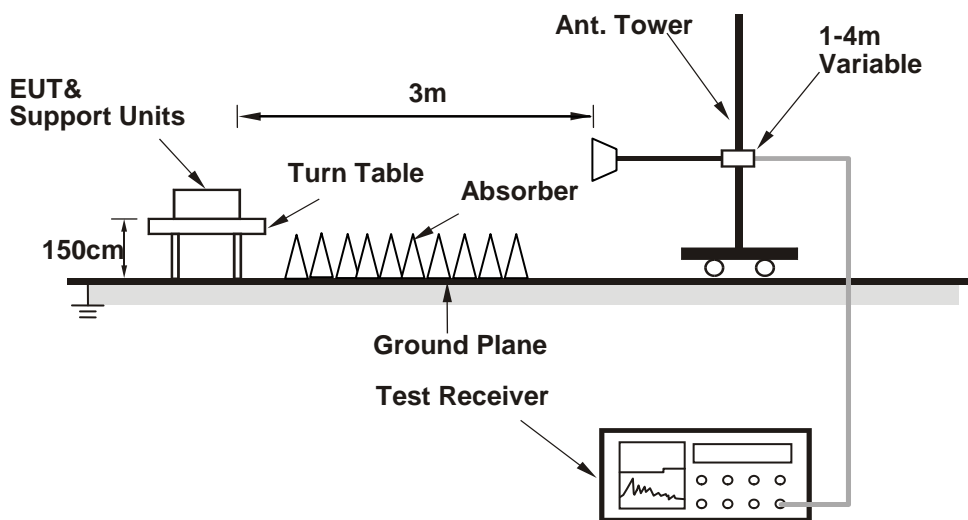

For the actual test configuration, please refer to the attached file (Test Setup Photo).

Conducted Power Measurement:

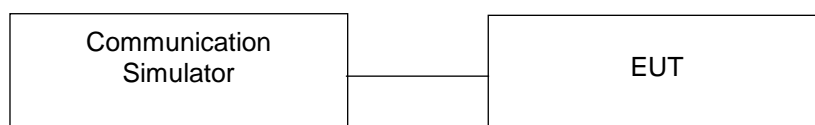

4.1.4 Test Results

Conducted Output Power (dBm)

LTE Band 4

BW (MHz): 5

Test Frequency ID	N _{UL}	Frequency of Uplink [MHz]	N _{DL}	Frequency of Downlink [MHz]	Test Configuration				Initial of Power		EUT	
					Modulation	RB Size	RB Offset	Narrowband Index	Cell power (dBm/15kHz)	power (dBm)		
Low Range	19975	1712.5	1975	2112.5	QPSK	1	0	0	-85	23.67		
					QPSK	1	5	0	-85	23.55		
					QPSK	1	0	1	-85	23.62		
					QPSK	1	5	1	-85	23.51		
					QPSK	1	0	3	-85	23.65		
					QPSK	1	5	3	-85	23.49		
					QPSK	3	0	0	-85	22.75		
					QPSK	3	3	3	-85	22.68		
					QPSK	6	0	0	-85	22.77		
					QPSK	6	0	1	-85	22.71		
					QPSK	6	0	3	-85	22.65		
					16QAM	1	0	0	-85	23.65		
					16QAM	1	5	0	-85	23.61		
					16QAM	1	0	1	-85	23.53		
					16QAM	1	5	1	-85	23.54		
					16QAM	1	0	3	-85	23.62		
					16QAM	1	5	3	-85	23.49		
					16QAM	3	0	0	-85	22.66		
					16QAM	3	3	3	-85	22.61		
					16QAM	5	0	0	-85	21.78		
16QAM	5	0	1	-85	21.65							
16QAM	5	0	3	-85	21.73							
Mid Range	20175	1732.5	2175	2132.5	QPSK	1	0	0	-85	23.67		
					QPSK	1	5	0	-85	23.63		
					QPSK	1	0	1	-85	23.63		
					QPSK	1	5	1	-85	23.58		
					QPSK	1	0	3	-85	23.59		
					QPSK	1	5	3	-85	23.60		
					QPSK	3	0	0	-85	22.75		
					QPSK	3	3	3	-85	22.65		
					QPSK	6	0	0	-85	22.72		
					QPSK	6	0	1	-85	22.65		
					QPSK	6	0	3	-85	22.64		
					16QAM	1	0	0	-85	23.52		
					16QAM	1	5	0	-85	23.59		
					16QAM	1	0	1	-85	23.45		
					16QAM	1	5	1	-85	23.48		
					16QAM	1	0	3	-85	23.39		
					16QAM	1	5	3	-85	23.46		
					16QAM	3	0	0	-85	22.66		
					16QAM	3	3	3	-85	22.60		
					16QAM	5	0	0	-85	21.67		
16QAM	5	0	1	-85	21.64							
16QAM	5	0	3	-85	21.61							

Test Frequency ID	N _{UL}	Frequency of Uplink [MHz]	N _{DL}	Frequency of Downlink [MHz]	Test Configuration Initial of Power				EUT	
					Modulation	RB Size	RB Offset	Narrowband Index	Cell power (dBm/15kHz)	power (dBm)
High Range	20375	1752.5	2375	2152.5	QPSK	1	0	0	-85	23.65
					QPSK	1	5	0	-85	23.61
					QPSK	1	0	1	-85	23.58
					QPSK	1	5	1	-85	23.54
					QPSK	1	0	3	-85	23.58
					QPSK	1	5	3	-85	23.47
					QPSK	3	0	0	-85	22.70
					QPSK	3	3	3	-85	22.66
					QPSK	6	0	0	-85	22.67
					QPSK	6	0	1	-85	22.63
					QPSK	6	0	3	-85	22.64
					16QAM	1	0	0	-85	23.61
					16QAM	1	5	0	-85	23.55
					16QAM	1	0	1	-85	23.49
					16QAM	1	5	1	-85	23.52
					16QAM	1	0	3	-85	23.49
					16QAM	1	5	3	-85	23.43
					16QAM	3	0	0	-85	22.68
					16QAM	3	3	3	-85	22.58
					16QAM	5	0	0	-85	21.79
16QAM	5	0	1	-85	21.77					
16QAM	5	0	3	-85	21.73					

BW (MHz): 10												
Test Frequency ID	N _{UL}	Frequency of Uplink [MHz]	N _{DL}	Frequency of Downlink [MHz]	Test Configuration				Initial of Power		EUT	
					Modulation	RB Size	RB Offset	Narrowband Index	Cell power (dBm/15kHz)	power (dBm)		
Low Range	20000	1715	2000	2115	QPSK	1	0	0	-85	23.60		
					QPSK	1	5	0	-85	23.64		
					QPSK	1	0	3	-85	23.53		
					QPSK	1	5	3	-85	23.53		
					QPSK	1	0	7	-85	23.49		
					QPSK	1	5	7	-85	23.56		
					QPSK	4	0	0	-85	23.52		
					QPSK	4	2	7	-85	23.48		
					QPSK	6	0	0	-85	22.65		
					QPSK	6	0	7	-85	22.51		
					16QAM	1	0	0	-85	23.42		
					16QAM	1	5	0	-85	23.43		
					16QAM	1	0	3	-85	23.31		
					16QAM	1	5	3	-85	23.38		
					16QAM	1	0	7	-85	23.34		
					16QAM	1	5	7	-85	23.33		
					16QAM	4	2	0	-85	22.54		
					16QAM	4	2	7	-85	22.43		
16QAM	5	0	0	-85	22.58							
16QAM	5	0	7	-85	22.51							
Mid Range	20175	1732.5	2175	2132.5	QPSK	1	0	0	-85	23.65		
					QPSK	1	5	0	-85	23.66		
					QPSK	1	0	3	-85	23.61		
					QPSK	1	5	3	-85	23.59		
					QPSK	1	0	7	-85	23.55		
					QPSK	1	5	7	-85	23.59		
					QPSK	4	0	0	-85	23.59		
					QPSK	4	2	7	-85	23.47		
					QPSK	6	0	0	-85	22.68		
					QPSK	6	0	7	-85	22.62		
					16QAM	1	0	0	-85	23.49		
					16QAM	1	5	0	-85	23.42		
					16QAM	1	0	3	-85	23.40		
					16QAM	1	5	3	-85	23.37		
					16QAM	1	0	7	-85	23.46		
					16QAM	1	5	7	-85	23.37		
					16QAM	4	2	0	-85	22.57		
					16QAM	4	2	7	-85	22.55		
16QAM	5	0	0	-85	22.68							
16QAM	5	0	7	-85	22.66							
High Range	20350	1750	2350	2150	QPSK	1	0	0	-85	23.65		
					QPSK	1	5	0	-85	23.64		
					QPSK	1	5	7	-85	23.62		
					QPSK	1	0	3	-85	23.60		
					QPSK	1	5	3	-85	23.59		
					QPSK	1	0	7	-85	23.62		
					QPSK	4	0	0	-85	23.54		
					QPSK	4	2	7	-85	23.41		
					QPSK	6	0	0	-85	22.65		
					QPSK	6	0	7	-85	22.61		
					16QAM	1	0	0	-85	23.36		
					16QAM	1	5	0	-85	23.23		
					16QAM	1	0	3	-85	23.29		
					16QAM	1	5	3	-85	23.09		
					16QAM	1	0	7	-85	23.26		
					16QAM	1	5	7	-85	23.12		
					16QAM	4	2	0	-85	22.56		
					16QAM	4	2	7	-85	22.49		
16QAM	5	0	0	-85	22.52							
16QAM	5	0	7	-85	22.44							

BW (MHz): 15												
Test Frequency ID	N _{UL}	Frequency of Uplink [MHz]	N _{DL}	Frequency of Downlink [MHz]	Test Configuration				Initial of Power		EUT	
					Modulation	RB Size	RB Offset	Narrowband Index	Cell power (dBm/15kHz)	power (dBm)		
Low Range	20025	1717.5	2025	2117.5	QPSK	1	0	0	-85	23.61		
					QPSK	1	5	0	-85	23.67		
					QPSK	1	0	5	-85	23.58		
					QPSK	1	5	5	-85	23.53		
					QPSK	1	0	11	-85	23.56		
					QPSK	1	5	11	-85	23.60		
					QPSK	3	0	0	-85	23.56		
					QPSK	3	3	11	-85	23.50		
					QPSK	6	0	0	-85	23.58		
					QPSK	6	0	11	-85	23.56		
					16QAM	1	0	0	-85	23.48		
					16QAM	1	5	0	-85	23.64		
					16QAM	1	0	5	-85	23.41		
					16QAM	1	5	5	-85	23.54		
					16QAM	1	0	11	-85	23.34		
					16QAM	1	5	11	-85	23.58		
					16QAM	3	0	0	-85	23.39		
					16QAM	3	3	11	-85	23.34		
16QAM	5	0	0	-85	23.28							
16QAM	5	0	11	-85	23.22							
Mid Range	20175	1732.5	2175	2132.5	QPSK	1	0	0	-85	23.61		
					QPSK	1	5	0	-85	23.62		
					QPSK	1	0	5	-85	23.49		
					QPSK	1	5	5	-85	23.56		
					QPSK	1	0	11	-85	23.55		
					QPSK	1	5	11	-85	23.58		
					QPSK	3	0	0	-85	23.51		
					QPSK	3	3	11	-85	23.41		
					QPSK	6	0	0	-85	23.54		
					QPSK	6	0	11	-85	23.46		
					16QAM	1	0	0	-85	23.58		
					16QAM	1	5	0	-85	23.61		
					16QAM	1	0	5	-85	23.48		
					16QAM	1	5	5	-85	23.51		
					16QAM	1	0	11	-85	23.46		
					16QAM	1	5	11	-85	23.58		
					16QAM	3	0	0	-85	23.39		
					16QAM	3	3	11	-85	23.31		
16QAM	5	0	0	-85	23.28							
16QAM	5	0	11	-85	23.24							
High Range	20325	1747.5	2325	2147.5	QPSK	1	0	0	-85	23.61		
					QPSK	1	5	11	-85	23.61		
					QPSK	1	0	5	-85	23.53		
					QPSK	1	5	5	-85	23.58		
					QPSK	1	0	11	-85	23.51		
					QPSK	1	5	11	-85	23.48		
					QPSK	3	0	0	-85	23.57		
					QPSK	3	3	11	-85	23.52		
					QPSK	6	0	0	-85	23.55		
					QPSK	6	0	11	-85	23.50		
					16QAM	1	0	0	-85	23.55		
					16QAM	1	5	0	-85	23.53		
					16QAM	1	0	5	-85	23.46		
					16QAM	1	5	5	-85	23.39		
					16QAM	1	0	11	-85	23.42		
					16QAM	1	5	11	-85	23.51		
					16QAM	3	0	0	-85	23.47		
					16QAM	3	3	11	-85	23.41		
16QAM	5	0	0	-85	23.44							
16QAM	5	0	11	-85	23.33							

BW (MHz): 20

Test Frequency ID	N _{UL}	Frequency of Uplink [MHz]	N _{DL}	Frequency of Downlink [MHz]	Test Configuration				Initial of Power		EUT	
					Modulation	RB Size	RB Offset	Narrowband Index	Cell power (dBm/15kHz)	power (dBm)		
Low Range	20050	1720	2050	2120	QPSK	1	0	0	-85	23.69		
					QPSK	1	5	0	-85	23.71		
					QPSK	1	0	7	-85	23.57		
					QPSK	1	5	7	-85	23.66		
					QPSK	1	0	15	-85	23.62		
					QPSK	1	5	15	-85	23.63		
					QPSK	3	0	0	-85	23.57		
					QPSK	3	3	15	-85	23.55		
					QPSK	6	0	0	-85	23.59		
					QPSK	6	0	15	-85	23.54		
					16QAM	1	0	0	-85	23.60		
					16QAM	1	5	0	-85	23.29		
					16QAM	1	0	7	-85	23.48		
					16QAM	1	5	7	-85	23.23		
					16QAM	1	0	15	-85	23.53		
					16QAM	1	5	15	-85	23.20		
					16QAM	3	0	0	-85	23.44		
					16QAM	3	3	15	-85	23.37		
16QAM	5	0	0	-85	23.46							
16QAM	5	0	15	-85	23.39							
Mid Range	20175	1732.5	2175	2132.5	QPSK	1	0	0	-85	23.57		
					QPSK	1	5	0	-85	23.53		
					QPSK	1	0	7	-85	23.44		
					QPSK	1	5	7	-85	23.51		
					QPSK	1	0	15	-85	23.50		
					QPSK	1	5	15	-85	23.45		
					QPSK	3	0	0	-85	23.51		
					QPSK	3	3	15	-85	23.46		
					QPSK	6	0	0	-85	23.49		
					QPSK	6	0	15	-85	23.47		
					16QAM	1	0	0	-85	23.54		
					16QAM	1	5	0	-85	23.48		
					16QAM	1	0	7	-85	23.46		
					16QAM	1	5	7	-85	23.42		
					16QAM	1	0	15	-85	23.47		
					16QAM	1	5	15	-85	23.40		
					16QAM	3	0	0	-85	23.46		
					16QAM	3	3	15	-85	23.36		
16QAM	5	0	0	-85	23.37							
16QAM	5	0	15	-85	23.34							
High Range	20300	1745	2300	2145	QPSK	1	0	0	-85	23.56		
					QPSK	1	5	0	-85	23.55		
					QPSK	1	0	7	-85	23.53		
					QPSK	1	5	7	-85	23.52		
					QPSK	1	0	15	-85	23.44		
					QPSK	1	5	15	-85	23.41		
					QPSK	3	0	0	-85	23.54		
					QPSK	3	3	15	-85	23.42		
					QPSK	6	0	0	-85	23.50		
					QPSK	6	0	15	-85	23.43		
					16QAM	1	0	0	-85	23.42		
					16QAM	1	5	0	-85	23.33		
					16QAM	1	0	7	-85	23.30		
					16QAM	1	5	7	-85	23.24		
					16QAM	1	0	15	-85	23.34		
					16QAM	1	5	15	-85	23.25		
					16QAM	3	0	0	-85	23.31		
					16QAM	3	3	15	-85	23.22		
16QAM	5	0	0	-85	23.28							
16QAM	5	0	15	-85	23.14							

LTE Band 13

BW (MHz): 5												
Test Frequency ID	N _{UL}	Frequency of Uplink [MHz]	N _{DL}	Frequency of Downlink [MHz]	Test Configuration				Initial of Power		EUT	
					Modulation	RB Size	RB Offset	Narrowband Index	Cell power (dBm/15kHz)	power (dBm)		
Low Range	23205	779.5	5205	748.5	QPSK	1	0	0	-85	23.71		
					QPSK	1	5	0	-85	23.75		
					QPSK	1	0	1	-85	23.66		
					QPSK	1	5	1	-85	23.62		
					QPSK	1	0	3	-85	23.64		
					QPSK	1	5	3	-85	23.71		
					QPSK	3	0	0	-85	22.94		
					QPSK	3	3	3	-85	22.90		
					QPSK	6	0	0	-85	22.98		
					QPSK	6	0	1	-85	22.92		
					QPSK	6	0	3	-85	22.96		
					16QAM	1	0	0	-85	23.48		
					16QAM	1	5	0	-85	23.47		
					16QAM	1	0	1	-85	23.34		
					16QAM	1	5	1	-85	23.40		
					16QAM	1	0	3	-85	23.36		
					16QAM	1	5	3	-85	23.41		
					16QAM	3	0	0	-85	22.91		
					16QAM	3	3	3	-85	22.85		
					16QAM	5	0	0	-85	22.25		
16QAM	5	0	1	-85	22.16							
16QAM	5	0	3	-85	22.18							
Mid Range	23230	782	5230	751	QPSK	1	0	0	-85	23.83		
					QPSK	1	5	0	-85	23.82		
					QPSK	1	0	1	-85	23.81		
					QPSK	1	5	1	-85	23.79		
					QPSK	1	0	3	-85	23.83		
					QPSK	1	5	3	-85	23.74		
					QPSK	3	0	0	-85	23.07		
					QPSK	3	3	3	-85	22.98		
					QPSK	6	0	0	-85	23.04		
					QPSK	6	0	1	-85	22.90		
					QPSK	6	0	3	-85	22.91		
					16QAM	1	0	0	-85	23.85		
					16QAM	1	5	0	-85	23.83		
					16QAM	1	0	1	-85	23.74		
					16QAM	1	5	1	-85	23.77		
					16QAM	1	0	3	-85	23.77		
					16QAM	1	5	3	-85	23.75		
					16QAM	3	0	0	-85	23.19		
					16QAM	3	3	3	-85	23.10		
					16QAM	5	0	0	-85	22.12		
16QAM	5	0	1	-85	22.00							
16QAM	5	0	3	-85	22.09							

Test Frequency ID	N _{UL}	Frequency of Uplink [MHz]	N _{DL}	Frequency of Downlink [MHz]	Test ConfigurationInitial of Power				EUT	
					Modulation	RB Size	RB Offset	Narrowband Index	Cell power (dBm/15kHz)	power (dBm)
High Range	23255	784.5	5255	753.5	QPSK	1	0	0	-85	23.75
					QPSK	1	5	0	-85	23.76
					QPSK	1	0	1	-85	23.65
					QPSK	1	5	1	-85	23.74
					QPSK	1	0	3	-85	23.69
					QPSK	1	5	3	-85	23.68
					QPSK	3	0	0	-85	23.08
					QPSK	3	3	3	-85	22.97
					QPSK	6	0	0	-85	23.02
					QPSK	6	0	1	-85	22.98
					QPSK	6	0	3	-85	22.93
					16QAM	1	0	0	-85	23.59
					16QAM	1	5	0	-85	23.60
					16QAM	1	0	1	-85	23.48
					16QAM	1	5	1	-85	23.49
					16QAM	1	0	3	-85	23.47
					16QAM	1	5	3	-85	23.58
					16QAM	3	0	0	-85	23.05
					16QAM	3	3	3	-85	23.03
16QAM	5	0	0	-85	22.26					
16QAM	5	0	1	-85	22.18					
16QAM	5	0	3	-85	22.22					

BW (MHz): 10										
Test Frequency ID	N _{UL}	Frequency of Uplink [MHz]	N _{DL}	Frequency of Downlink [MHz]	Test ConfigurationInitial of Power				EUT	
					Modulation	RB Size	RB Offset	Narrowband Index	Cell power (dBm/15kHz)	power (dBm)
Mid Range	23230	782	5230	751	QPSK	1	0	0	-85	23.86
					QPSK	1	5	0	-85	23.77
					QPSK	1	0	3	-85	23.73
					QPSK	1	5	3	-85	23.74
					QPSK	1	0	7	-85	23.82
					QPSK	1	5	7	-85	23.63
					QPSK	4	0	0	-85	23.74
					QPSK	4	2	7	-85	23.71
					QPSK	6	0	0	-85	23.06
					QPSK	6	0	7	-85	22.94
					16QAM	1	0	0	-85	23.57
					16QAM	1	5	0	-85	23.55
					16QAM	1	0	3	-85	23.51
					16QAM	1	5	3	-85	23.48
					16QAM	1	0	7	-85	23.46
					16QAM	1	5	7	-85	23.41
					16QAM	4	2	0	-85	22.91
					16QAM	4	2	7	-85	22.77
					16QAM	5	0	0	-85	22.98
16QAM	5	0	7	-85	22.92					

ERP Power (dBm)

1RB

LTE Band 13									
Channel Bandwidth: 5 MHz / QPSK									
Plane	Channel	Frequency (MHz)	RB	RB Offset	LVL (dBm)	Correction Factor (dB)	ERP (dBm)	ERP (mW)	Polarization (H/V)
Z	23205	779.5	1	0	-11.16	32.24	18.93	78.16	H
	23230	782.0	1	0	-11.34	32.17	18.68	73.79	
	23255	784.5	1	0	-11.68	32.11	18.28	67.30	
	23205	779.5	1	0	-8.27	32.43	22.01	158.85	V
	23230	782.0	1	0	-8.61	32.42	21.66	146.55	
	23255	784.5	1	0	-8.87	32.46	21.44	139.32	
Channel Bandwidth: 5 MHz / 16QAM									
Z	23205	779.5	1	0	-12.26	32.24	17.83	60.67	H
	23230	782.0	1	0	-12.44	32.17	17.58	57.28	
	23255	784.5	1	0	-12.78	32.11	17.18	52.24	
	23205	779.5	1	0	-9.37	32.43	20.91	123.31	V
	23230	782.0	1	0	-9.71	32.42	20.56	113.76	
	23255	784.5	1	0	-9.97	32.46	20.34	108.14	

LTE Band 13									
Channel Bandwidth: 10 MHz / QPSK									
Plane	Channel	Frequency (MHz)	RB	RB Offset	LVL (dBm)	Correction Factor (dB)	ERP (dBm)	ERP (mW)	Polarization (H/V)
Z	23230	782.0	1	0	-11.25	32.17	18.77	75.34	H
	23230	782.0	1	0	-8.48	32.42	21.79	151.01	V
Channel Bandwidth: 10 MHz / 16QAM									
Z	23230	782.0	1	0	-12.15	32.17	17.87	61.24	H
	23230	782.0	1	0	-9.38	32.42	20.89	122.74	V

Full RB

LTE Band 13									
Channel Bandwidth: 5 MHz / QPSK									
Plane	Channel	Frequency (MHz)	RB	RB Offset	LVL (dBm)	Correction Factor (dB)	ERP (dBm)	ERP (mW)	Polarization (H/V)
Z	23205	779.5	6	0	-12.06	32.24	18.03	63.53	H
	23230	782.0	6	0	-12.24	32.17	17.78	59.98	
	23255	784.5	6	0	-12.58	32.11	17.38	54.70	
	23205	779.5	6	0	-9.17	32.43	21.11	129.12	V
	23230	782.0	6	0	-9.51	32.42	20.76	119.12	
	23255	784.5	6	0	-9.77	32.46	20.54	113.24	
Channel Bandwidth: 5 MHz / 16QAM									
Z	23205	779.5	5	0	-13.36	32.24	16.73	47.10	H
	23230	782.0	5	0	-13.54	32.17	16.48	44.46	
	23255	784.5	5	0	-13.88	32.11	16.08	40.55	
	23205	779.5	5	0	-10.47	32.43	19.81	95.72	V
	23230	782.0	5	0	-10.81	32.42	19.46	88.31	
	23255	784.5	5	0	-11.07	32.46	19.24	83.95	

LTE Band 13									
Channel Bandwidth: 10 MHz / QPSK									
Plane	Channel	Frequency (MHz)	RB	RB Offset	LVL (dBm)	Correction Factor (dB)	ERP (dBm)	ERP (mW)	Polarization (H/V)
Z	23230	782.0	6	0	-12.15	32.17	17.87	61.24	H
	23230	782.0	6	0	-9.38	32.42	20.89	122.74	V
Channel Bandwidth: 10 MHz / 16QAM									
Z	23230	782.0	5	0	-13.25	32.17	16.77	47.53	H
	23230	782.0	5	0	-10.48	32.42	19.79	95.28	V

EIRP Power (dBm)

LTE Band 4									
Channel Bandwidth: 5 MHz / QPSK									
Plane	Channel	Frequency (MHz)	RB	RB Offset	LVL (dBm)	Correction Factor (dB)	EIRP (dBm)	EIRP (mW)	Polarization (H/V)
Z	19975	1712.5	1	0	-16.98	36.45	19.48	88.61	H
	20175	1732.5	1	0	-17.00	36.80	19.80	95.48	
	20375	1752.5	1	0	-17.08	36.94	19.86	96.85	
	19975	1712.5	1	0	-13.58	37.28	23.70	234.42	V
	20175	1732.5	1	0	-13.66	37.63	23.97	249.46	
	20375	1752.5	1	0	-13.47	37.64	24.17	261.22	
Channel Bandwidth: 5 MHz / 16QAM									
Z	19975	1712.5	1	0	-17.96	36.45	18.50	70.71	H
	20175	1732.5	1	0	-17.99	36.80	18.81	76.02	
	20375	1752.5	1	0	-18.00	36.94	18.94	78.36	
	19975	1712.5	1	0	-14.57	37.28	22.71	186.64	V
	20175	1732.5	1	0	-14.64	37.63	22.99	199.07	
	20375	1752.5	1	0	-14.39	37.64	23.25	211.35	
LTE Band 4									
Channel Bandwidth: 10 MHz / QPSK									
Plane	Channel	Frequency (MHz)	RB	RB Offset	LVL (dBm)	Correction Factor (dB)	EIRP (dBm)	EIRP (mW)	Polarization (H/V)
Z	20000	1715.0	1	0	-16.33	36.64	20.31	107.40	H
	20175	1732.5	1	0	-16.25	36.80	20.55	113.47	
	20350	1750.0	1	0	-16.26	36.80	20.54	113.16	
	20000	1715.0	1	0	-12.91	37.44	24.53	283.79	V
	20175	1732.5	1	0	-12.88	37.63	24.75	298.47	
	20350	1750.0	1	0	-12.63	37.64	25.01	316.96	
Channel Bandwidth: 10 MHz / 16QAM									
Z	20000	1715.0	1	0	-17.32	36.64	19.32	85.51	H
	20175	1732.5	1	0	-17.20	36.80	19.60	91.18	
	20350	1750.0	1	0	-17.18	36.80	19.62	91.56	
	20000	1715.0	1	0	-13.85	37.44	23.59	228.56	V
	20175	1732.5	1	0	-13.82	37.63	23.81	240.38	
	20350	1750.0	1	0	-13.57	37.64	24.07	255.27	

LTE Band 4									
Channel Bandwidth: 15 MHz / QPSK									
Plane	Channel	Frequency (MHz)	RB	RB Offset	LVL (dBm)	Correction Factor (dB)	EIRP (dBm)	EIRP (mW)	Polarization (H/V)
Z	20025	1717.5	1	0	-16.01	36.45	20.45	110.79	H
	20175	1732.5	1	0	-16.06	36.80	20.74	118.55	
	20325	1747.5	1	0	-16.13	36.94	20.81	120.53	
	20025	1717.5	1	0	-12.56	37.28	24.72	296.48	V
	20175	1732.5	1	0	-12.71	37.63	24.92	310.46	
	20325	1747.5	1	0	-12.36	37.64	25.28	337.29	
Channel Bandwidth: 15 MHz / 16QAM									
Z	20025	1717.5	1	0	-16.93	36.45	19.53	89.64	H
	20175	1732.5	1	0	-16.97	36.80	19.83	96.14	
	20325	1747.5	1	0	-17.04	36.94	19.90	97.75	
	20025	1717.5	1	0	-13.51	37.28	23.77	238.23	V
	20175	1732.5	1	0	-13.66	37.63	23.97	249.46	
	20325	1747.5	1	0	-13.33	37.64	24.31	269.77	

LTE Band 4									
Channel Bandwidth: 20 MHz / QPSK									
Plane	Channel	Frequency (MHz)	RB	RB Offset	LVL (dBm)	Correction Factor (dB)	EIRP (dBm)	EIRP (mW)	Polarization (H/V)
Z	20050	1720.0	1	0	-15.91	36.45	20.55	113.37	H
	20175	1732.5	1	0	-15.90	36.80	20.90	123.00	
	20300	1745.0	1	0	-15.99	36.94	20.95	124.48	
	20050	1720.0	1	0	-12.45	37.28	24.83	304.09	V
	20175	1732.5	1	0	-12.54	37.63	25.09	322.85	
	20300	1745.0	1	0	-12.30	37.64	25.34	341.98	
Channel Bandwidth: 20 MHz / 16QAM									
Z	20050	1720.0	1	0	-16.83	36.45	19.63	91.73	H
	20175	1732.5	1	0	-16.82	36.80	19.98	99.52	
	20300	1745.0	1	0	-16.98	36.94	19.96	99.11	
	20050	1720.0	1	0	-13.41	37.28	23.87	243.78	V
	20175	1732.5	1	0	-13.47	37.63	24.16	260.62	
	20300	1745.0	1	0	-13.24	37.64	24.40	275.42	

4.2 Frequency Stability Measurement

4.2.1 Limits of Frequency Stability Measurement

The frequency stability shall be sufficient to ensure that the fundamental emissions stay within the authorized bands of operation.

4.2.2 Test Procedure

- Device is placed at the oven room. The oven room could control the temperatures and humidity. Power warm up is at least 15 min and power applied should perform before recording frequency error.
- EUT is connected the external power supply to control the DC input power. The test voltage range is from minimum to maximum working voltage. Each step shall be record the frequency error rate.
- The temperature range step is 10 degrees in this test items. All temperature levels shall be hold the ± 0.5 °C during the measurement testing. The each temperature step shall be at least 0.5 hours, consider the EUT could be test under the stability condition.

Note: The frequency error was recorded frequency error from the communication simulator.

4.2.3 Test Setup

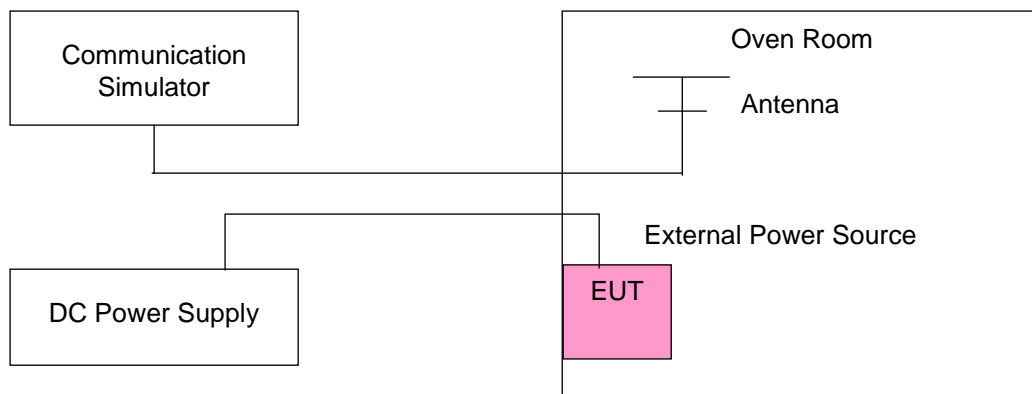

4.2.4 Test Results

Frequency Error vs. Voltage

Voltage (Volts)	LTE Band 4				Limit (ppm)
	Channel Bandwidth: 5 MHz				
	Low Channel		High Channel		
	Frequency (MHz)	Frequency Error (ppm)	Frequency (MHz)	Frequency Error (ppm)	
3.8	1712.500003	0.002	1752.500002	0.001	2.5
3.1	1712.500002	0.001	1752.500003	0.002	2.5
4.5	1712.500002	0.001	1752.500002	0.001	2.5

Note: The applicant defined the normal working voltage of the battery is from 3.1 Vdc to 4.5 Vdc.

Frequency Error vs. Temperature

Temp. (°C)	LTE Band 4				Limit (ppm)
	Channel Bandwidth: 5 MHz				
	Low Channel		High Channel		
	Frequency (MHz)	Frequency Error (ppm)	Frequency (MHz)	Frequency Error (ppm)	
-30	1712.500002	0.001	1752.500004	0.002	2.5
-20	1712.500002	0.001	1752.500002	0.001	2.5
-10	1712.500004	0.002	1752.500002	0.001	2.5
0	1712.500002	0.001	1752.500003	0.002	2.5
10	1712.500003	0.002	1752.500001	0.001	2.5
20	1712.500001	0.001	1752.500001	0.001	2.5
30	1712.500003	0.002	1752.500001	0.001	2.5
40	1712.499997	-0.002	1752.499998	-0.001	2.5
50	1712.499997	-0.002	1752.499996	-0.002	2.5
60	1712.499998	-0.001	1752.499997	-0.002	2.5
70	1712.499997	-0.002	1752.499998	-0.001	2.5
50	1712.499998	-0.001	1752.499999	-0.001	2.5
85	1712.499997	-0.002	1752.499999	-0.001	2.5

Note:

1. The applicant declared that the normal operating temperature of the EUT is from -20°C to 85°C.
2. The EUT would shut down automatically as below -20°C.

Frequency Error vs. Voltage

Voltage (Volts)	LTE Band 4				Limit (ppm)
	Channel Bandwidth: 10 MHz				
	Low Channel		High Channel		
	Frequency (MHz)	Frequency Error (ppm)	Frequency (MHz)	Frequency Error (ppm)	
3.8	1715.000003	0.002	1750.000003	0.002	2.5
3.1	1715.000003	0.002	1750.000002	0.001	2.5
4.5	1715.000004	0.002	1750.000001	0.001	2.5

Note: The applicant defined the normal working voltage of the battery is from 3.1 Vdc to 4.5 Vdc.

Frequency Error vs. Temperature

Temp. (°C)	LTE Band 4				Limit (ppm)
	Channel Bandwidth: 10 MHz				
	Low Channel		High Channel		
	Frequency (MHz)	Frequency Error (ppm)	Frequency (MHz)	Frequency Error (ppm)	
-30	1715.000002	0.001	1750.000001	0.001	2.5
-20	1715.000003	0.002	1750.000003	0.002	2.5
-10	1715.000002	0.001	1750.000003	0.001	2.5
0	1715.000002	0.001	1750.000003	0.002	2.5
10	1715.000003	0.002	1750.000002	0.001	2.5
20	1715.000002	0.001	1750.000004	0.002	2.5
30	1715.000002	0.001	1750.000001	0.001	2.5
40	1714.999997	-0.002	1749.999997	-0.002	2.5
50	1714.999998	-0.001	1749.999997	-0.002	2.5
60	1714.999999	-0.001	1749.999997	-0.002	2.5
70	1714.999998	-0.001	1749.999997	-0.002	2.5
50	1714.999997	-0.002	1749.999999	-0.001	2.5
85	1714.999997	-0.002	1749.999997	-0.002	2.5

Note:

1. The applicant declared that the normal operating temperature of the EUT is from -20°C to 85°C.
2. The EUT would shut down automatically as below -20°C.

Frequency Error vs. Voltage

Voltage (Volts)	LTE Band 4				Limit (ppm)
	Channel Bandwidth: 15 MHz				
	Low Channel		High Channel		
	Frequency (MHz)	Frequency Error (ppm)	Frequency (MHz)	Frequency Error (ppm)	
3.8	1717.500003	0.002	1747.500004	0.002	2.5
3.1	1717.500001	0.001	1747.500003	0.002	2.5
4.5	1717.500002	0.001	1747.500001	0.001	2.5

Note: The applicant defined the normal working voltage of the battery is from 3.1 Vdc to 4.5 Vdc.

Frequency Error vs. Temperature

Temp. (°C)	LTE Band 4				Limit (ppm)
	Channel Bandwidth: 15 MHz				
	Low Channel		High Channel		
	Frequency (MHz)	Frequency Error (ppm)	Frequency (MHz)	Frequency Error (ppm)	
-30	1717.500002	0.001	1747.500001	0.001	2.5
-20	1717.500003	0.002	1747.500003	0.002	2.5
-10	1717.500004	0.002	1747.500003	0.002	2.5
0	1717.500001	0.001	1747.500002	0.001	2.5
10	1717.500004	0.002	1747.500004	0.002	2.5
20	1717.500003	0.002	1747.500003	0.002	2.5
30	1717.500002	0.001	1747.500001	0.001	2.5
40	1717.499997	-0.002	1747.499998	-0.001	2.5
50	1717.499997	-0.002	1747.499997	-0.002	2.5
60	1717.499996	-0.002	1747.499999	-0.001	2.5
70	1717.499998	-0.001	1747.499998	-0.001	2.5
50	1717.499998	-0.001	1747.499998	-0.001	2.5
85	1717.499997	-0.002	1747.499999	-0.001	2.5

Note:

1. The applicant declared that the normal operating temperature of the EUT is from -20°C to 85°C.
2. The EUT would shut down automatically as below -20°C.

Frequency Error vs. Voltage

Voltage (Volts)	LTE Band 4				Limit (ppm)
	Channel Bandwidth: 20 MHz				
	Low Channel		High Channel		
	Frequency (MHz)	Frequency Error (ppm)	Frequency (MHz)	Frequency Error (ppm)	
3.8	1720.000004	0.002	1745.000004	0.002	2.5
3.1	1720.000003	0.002	1745.000001	0.001	2.5
4.5	1720.000001	0.001	1745.000002	0.001	2.5

Note: The applicant defined the normal working voltage of the battery is from 3.1 Vdc to 4.5 Vdc.

Frequency Error vs. Temperature

Temp. (°C)	LTE Band 4				Limit (ppm)
	Channel Bandwidth: 20 MHz				
	Low Channel		High Channel		
	Frequency (MHz)	Frequency Error (ppm)	Frequency (MHz)	Frequency Error (ppm)	
-30	1720.000001	0.001	1745.000002	0.001	2.5
-20	1720.000001	0.001	1745.000001	0.001	2.5
-10	1720.000003	0.002	1745.000003	0.001	2.5
0	1720.000003	0.002	1745.000003	0.002	2.5
10	1720.000003	0.002	1745.000003	0.002	2.5
20	1720.000003	0.001	1745.000002	0.001	2.5
30	1720.000003	0.002	1745.000002	0.001	2.5
40	1719.999998	-0.001	1744.999998	-0.001	2.5
50	1719.999997	-0.002	1744.999997	-0.002	2.5
60	1719.999998	-0.001	1744.999998	-0.001	2.5
70	1719.999999	-0.001	1744.999997	-0.002	2.5
50	1719.999997	-0.002	1744.999998	-0.001	2.5
85	1719.999998	-0.001	1744.999998	-0.001	2.5

Note:

1. The applicant declared that the normal operating temperature of the EUT is from -20°C to 85°C.
2. The EUT would shut down automatically as below -20°C.

Frequency Error vs. Voltage

Voltage (Volts)	LTE Band 13				Limit (ppm)
	Channel Bandwidth: 5 MHz				
	Low Channel		High Channel		
	Frequency (MHz)	Frequency Error (ppm)	Frequency (MHz)	Frequency Error (ppm)	
3.8	779.500004	0.004	784.500002	0.003	2.5
3.1	779.500003	0.004	784.500003	0.004	2.5
4.5	779.500001	0.002	784.500002	0.003	2.5

Note: The applicant defined the normal working voltage of the battery is from 3.1 Vdc to 4.5 Vdc.

Frequency Error vs. Temperature

Temp. (°C)	LTE Band 13				Limit (ppm)
	Channel Bandwidth: 5 MHz				
	Low Channel		High Channel		
	Frequency (MHz)	Frequency Error (ppm)	Frequency (MHz)	Frequency Error (ppm)	
-30	779.500001	0.002	784.500002	0.003	2.5
-20	779.500004	0.005	784.500002	0.002	2.5
-10	779.500003	0.003	784.500003	0.004	2.5
0	779.500003	0.004	784.500002	0.002	2.5
10	779.500002	0.003	784.500004	0.005	2.5
20	779.500002	0.003	784.500004	0.004	2.5
30	779.500003	0.004	784.500003	0.004	2.5
40	779.499998	-0.002	784.499998	-0.003	2.5
50	779.499998	-0.003	784.499998	-0.003	2.5
60	779.499997	-0.003	784.499998	-0.003	2.5
70	779.499999	-0.002	784.499998	-0.003	2.5
50	779.499998	-0.003	784.499998	-0.003	2.5
85	779.499997	-0.004	784.499997	-0.004	2.5

Note:

1. The applicant declared that the normal operating temperature of the EUT is from -20°C to 85°C.
2. The EUT would shut down automatically as below -20°C.

Frequency Error vs. Voltage

Voltage (Volts)	LTE Band 13		Limit (ppm)
	Channel Bandwidth: 10 MHz		
	Frequency (MHz)	Frequency Error (ppm)	
3.8	782.000004	0.005	2.5
3.1	782.000004	0.005	2.5
4.5	782.000004	0.005	2.5

Note: The applicant defined the normal working voltage of the battery is from 3.1 Vdc to 4.5 Vdc.

Frequency Error vs. Temperature

Temp. (°C)	LTE Band 13		Limit (ppm)
	Channel Bandwidth: 10 MHz		
	Frequency (MHz)	Frequency Error (ppm)	
-30	782.000003	0.004	2.5
-20	782.000003	0.004	2.5
-10	782.000002	0.003	2.5
0	782.000003	0.004	2.5
10	782.000003	0.004	2.5
20	782.000004	0.005	2.5
30	782.000004	0.004	2.5
40	781.999997	-0.004	2.5
50	781.999998	-0.002	2.5
60	781.999997	-0.004	2.5
70	781.999997	-0.004	2.5
50	781.999998	-0.003	2.5
85	781.999996	-0.005	2.5

Note:

1. The applicant declared that the normal operating temperature of the EUT is from -20°C to 85°C.
2. The EUT would shut down automatically as below -20°C.

4.3 Occupied Bandwidth Measurement

4.3.1 Limits of Occupied Bandwidth Measurement

The width of a frequency band such that, below the lower and above the upper frequency limits, the mean powers emitted are each equal to a specified percentage 0.5 % of the total mean power of a given emission.

4.3.2 Test Procedure

- The conducted occupied bandwidth used the power splitter via EUT RF power connector between simulation base station and spectrum analyzer.
- Use OBW measurement function of Spectrum analyzer to measure 99 % occupied bandwidth.

4.3.3 Test Setup

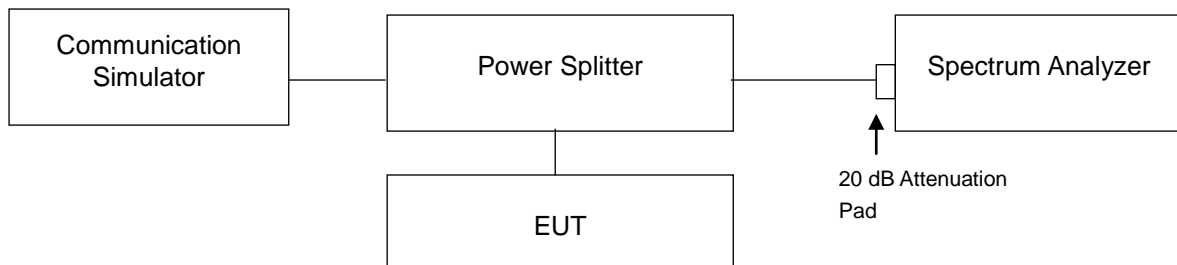

4.3.4 Test Result

LTE Band 4							
Channel Bandwidth: 5 MHz				Channel Bandwidth: 10 MHz			
Channel	Frequency (MHz)	99 % Occupied Bandwidth (MHz)		Channel	Frequency (MHz)	99 % Occupied Bandwidth (MHz)	
		QPSK	16QAM			QPSK	16QAM
19975	1712.5	1.09	0.91	20000	1715.0	1.09	0.91
20175	1732.5	1.09	0.92	20175	1732.5	1.09	0.92
20375	1752.5	1.09	0.92	20350	1750.0	1.09	0.91

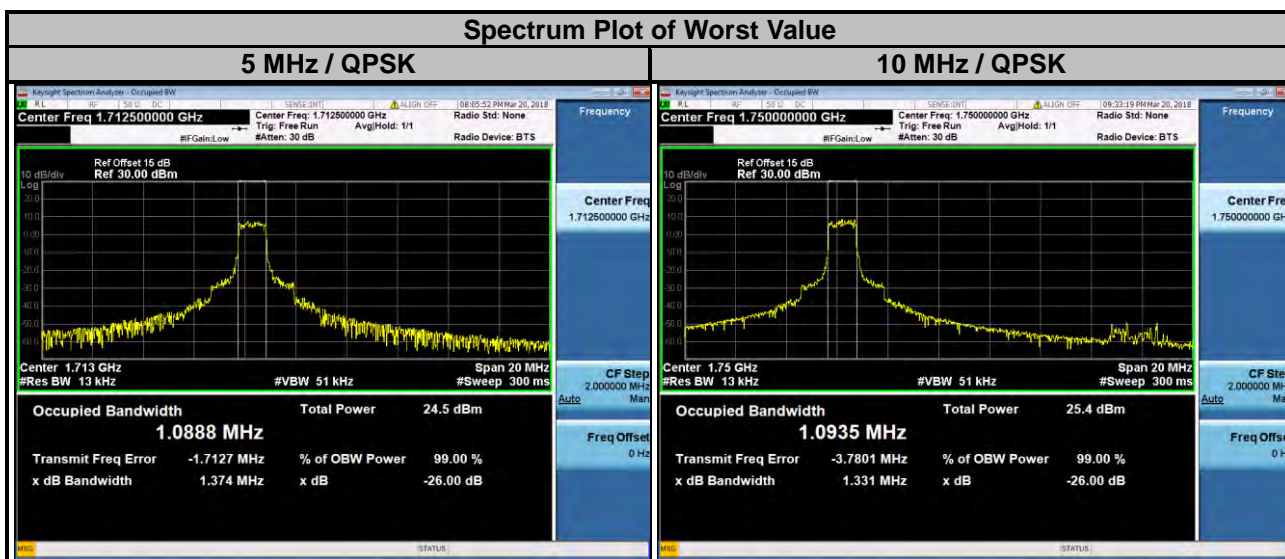

LTE Band 4

Channel Bandwidth: 15 MHz				Channel Bandwidth: 20 MHz			
Channel	Frequency (MHz)	99 % Occupied Bandwidth (MHz)		Channel	Frequency (MHz)	99 % Occupied Bandwidth (MHz)	
		QPSK	16QAM			QPSK	16QAM
20025	1717.5	1.08	0.92	20050	1720.0	1.09	0.92
20175	1732.5	1.09	0.93	20175	1732.5	1.09	0.92
20325	1747.5	1.10	0.92	20300	1745.0	1.09	0.92

Spectrum Plot of Worst Value

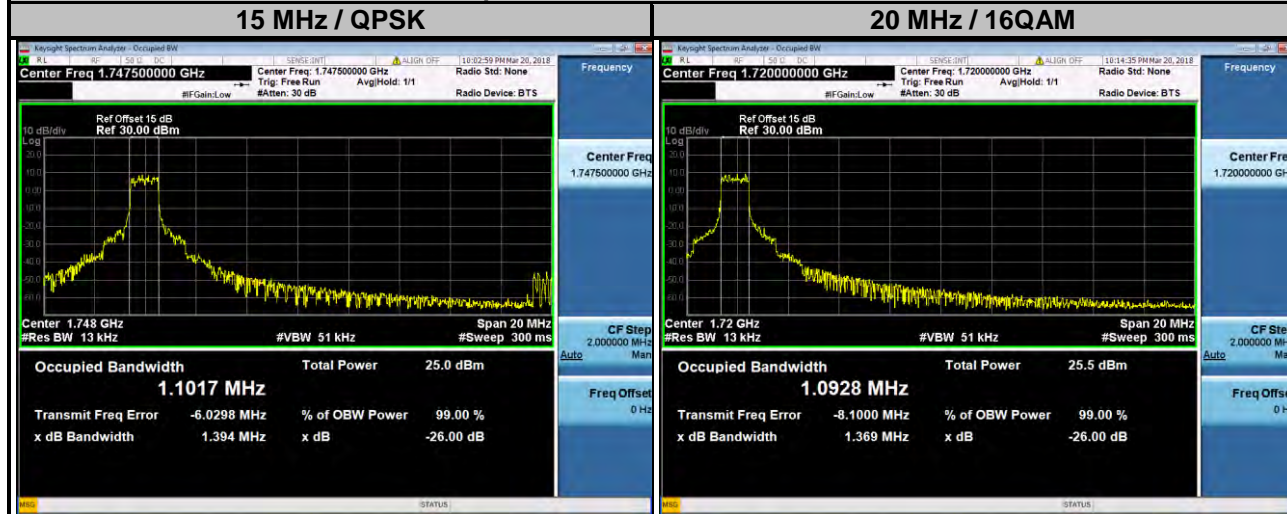

LTE Band 13

Channel Bandwidth: 5 MHz				Channel Bandwidth: 10 MHz			
Channel	Frequency (MHz)	99 % Occupied Bandwidth (MHz)		Channel	Frequency (MHz)	99 % Occupied Bandwidth (MHz)	
		QPSK	16QAM			QPSK	16QAM
23205	779.5	1.09	0.91	23230	782.0	1.09	1.01
23230	782.0	1.08	0.91				
23255	784.5	1.09	0.91				

Spectrum Plot of Worst Value

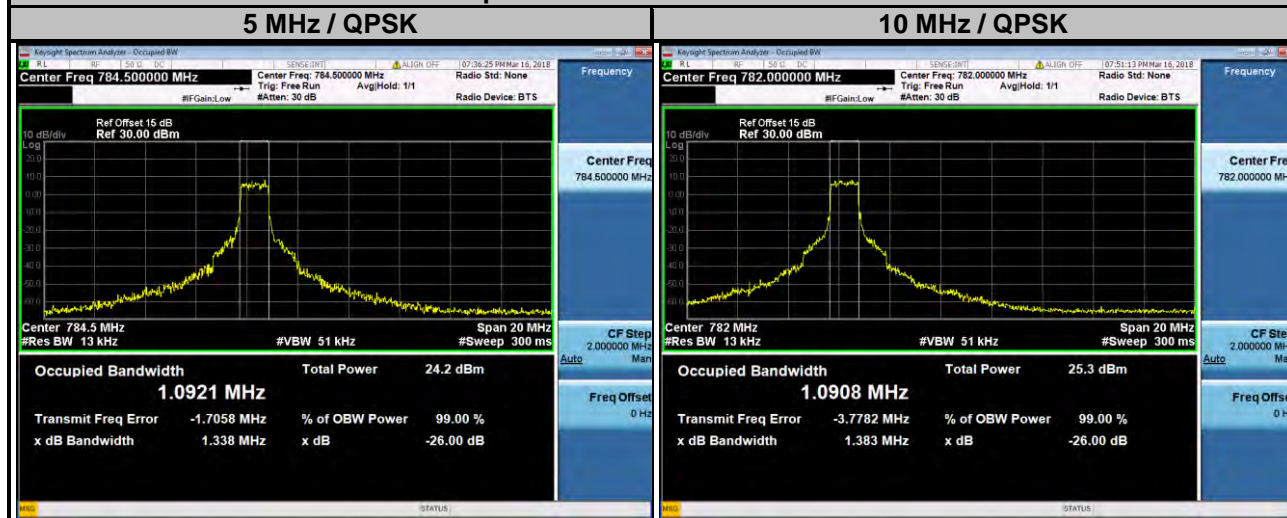

4.4 Band Edge Measurement

4.4.1 Limits of Band Edge Measurement

For operations in the 776-787 MHz band, the power of any emission outside a licensee's frequency band(s) of operation shall be attenuated below the transmitter power (P) within the licensed band(s) of operation, measured in watts, by at least $43 + 10 \log(P)$ dB. Compliance with this provision is based on the use of measurement instrumentation employing a resolution bandwidth of 100 kilohertz or greater.

However, in the 100 kilohertz bands immediately outside and adjacent to a licensee's frequency block, a resolution bandwidth of at least 30 kHz may be employed.

For operations in the 1710–1755 MHz bands, the power of any emission outside a licensee's frequency block shall be attenuated below the transmitter power (P) by at least $43 + 10 \log_{10}(P)$ dB.

4.4.2 Test Setup

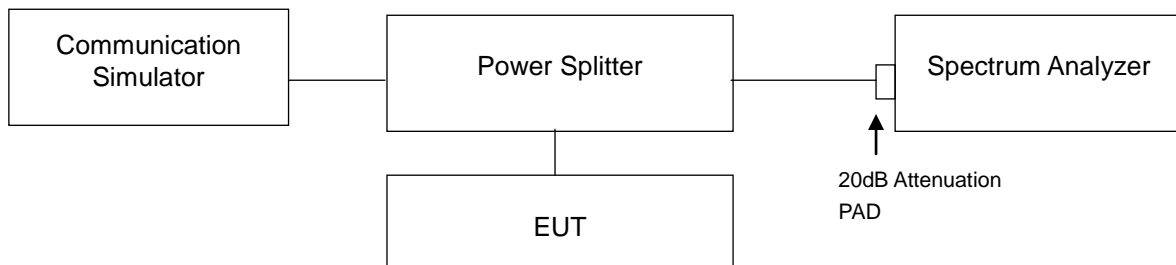

4.4.3 Test Procedures

- a. All measurements were done at low and high operational frequency range.
- b. The center frequency of spectrum is the band edge frequency and span is 1 MHz. RB of the spectrum is 30 kHz and VB of the spectrum is 100 kHz (LTE Bandwidth 3 MHz).
- c. The center frequency of spectrum is the band edge frequency and span is 1 MHz. RB of the spectrum is 100 kHz and VB of the spectrum is 300 kHz (LTE Bandwidth 5 MHz/10 MHz).
- d. The center frequency of spectrum is the band edge frequency and span is 1 MHz. RB of the spectrum is 150 kHz and VB of the spectrum is 470 kHz (LTE Bandwidth 15 MHz).
- e. The center frequency of spectrum is the band edge frequency and span is 1 MHz. RB of the spectrum is 180 kHz and VB of the spectrum is 560 kHz (LTE Bandwidth 20 MHz).
- f. Record the max. trace plot into the test report.

4.4.4 Test Results

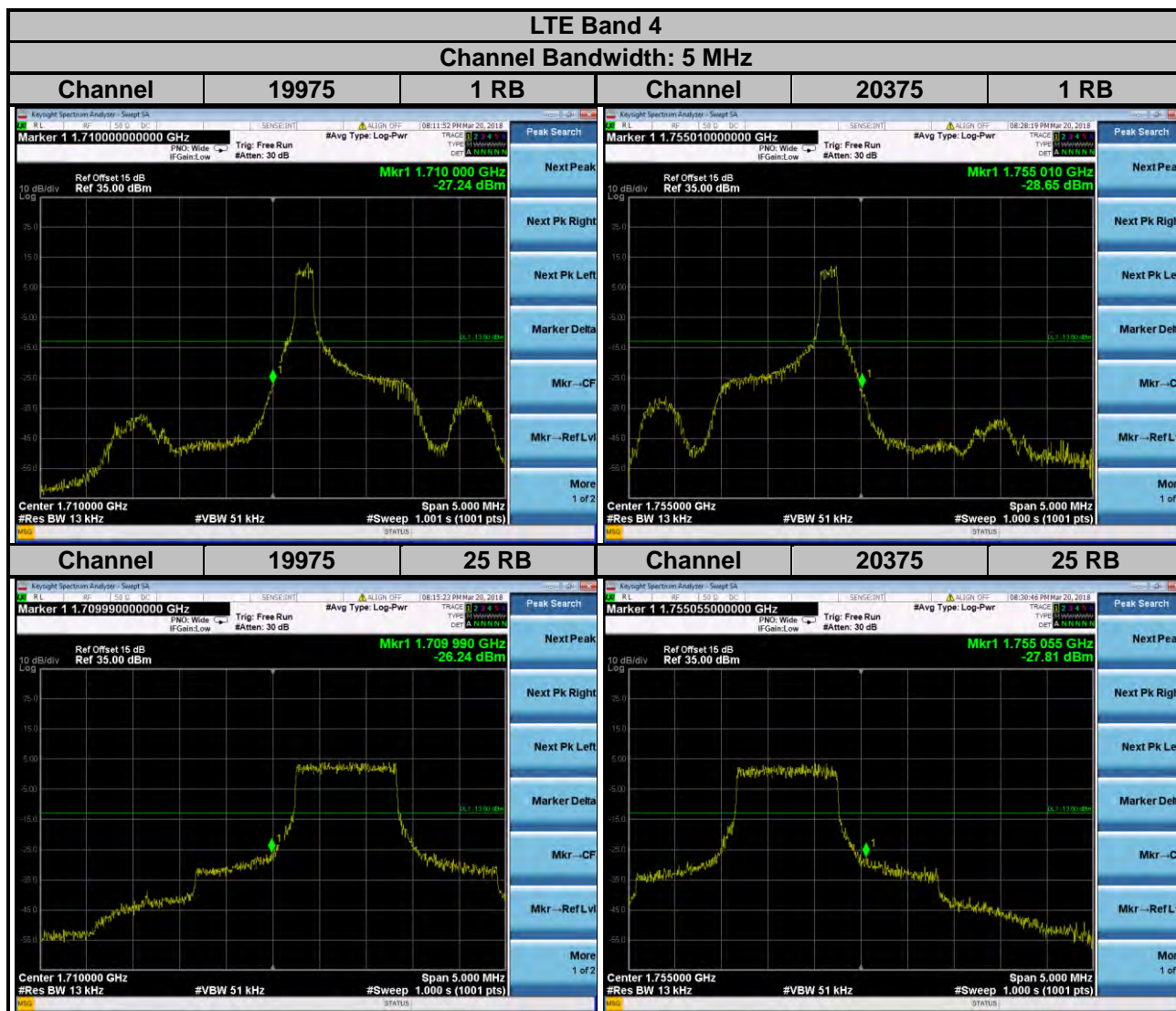

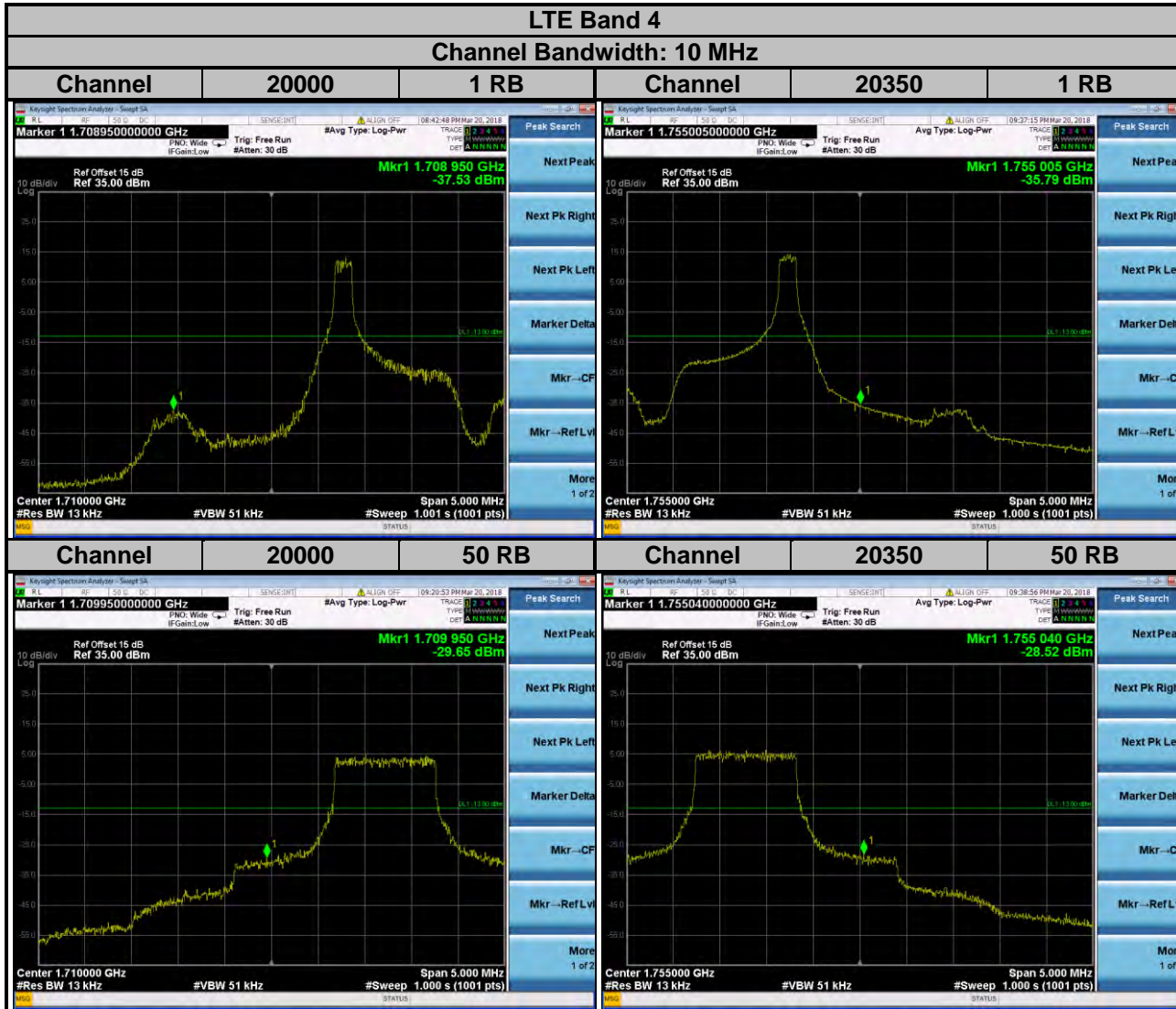

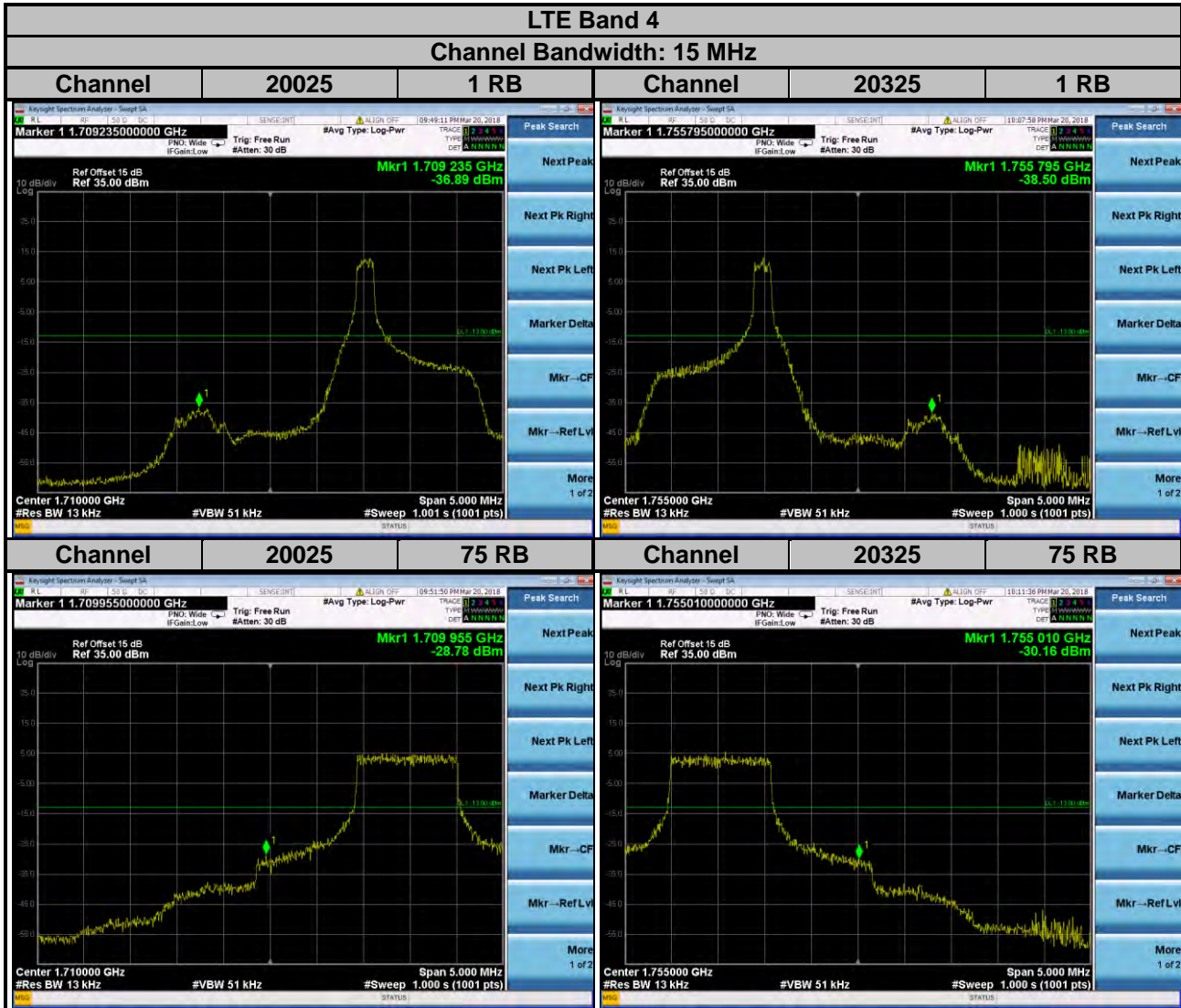

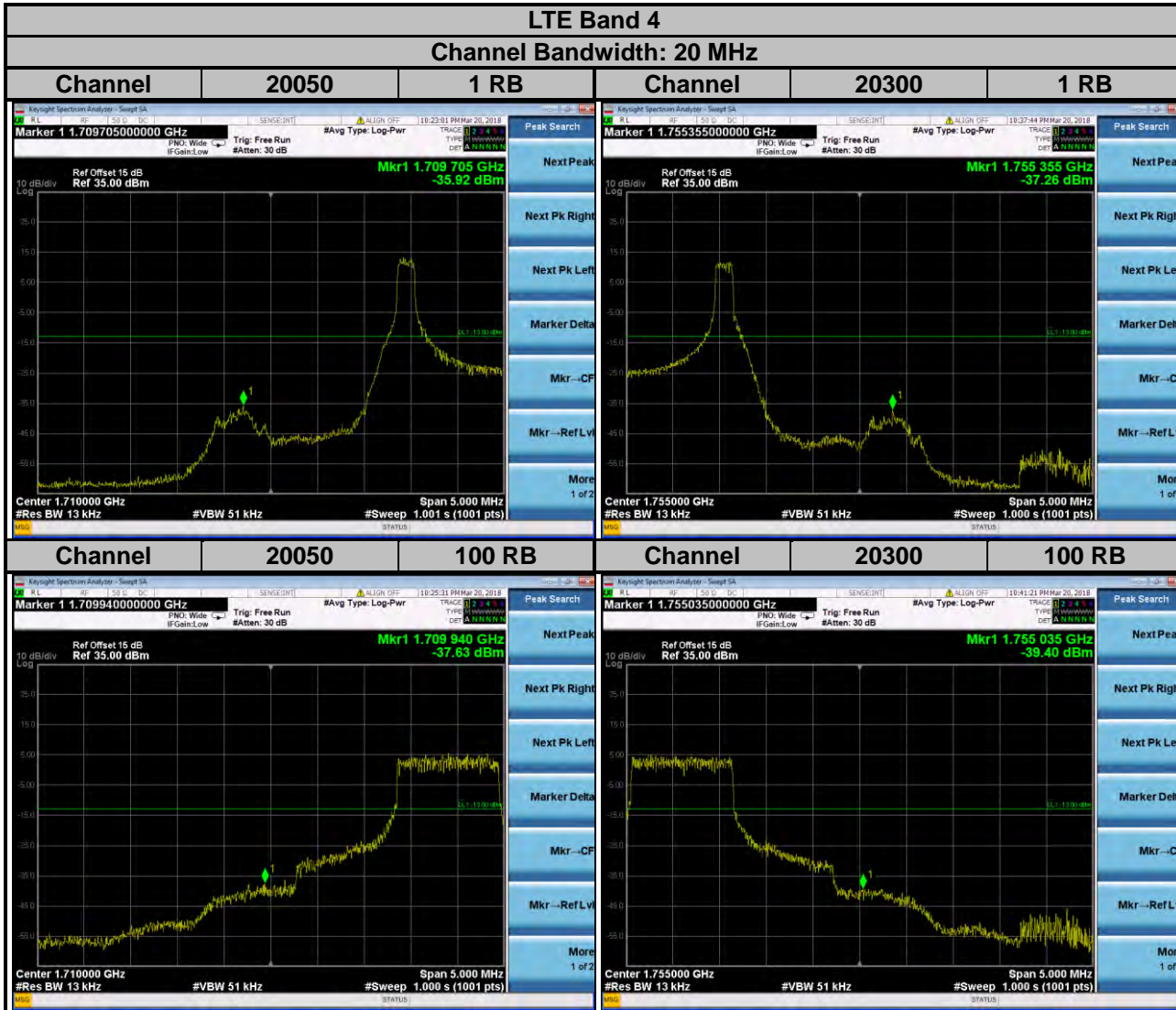

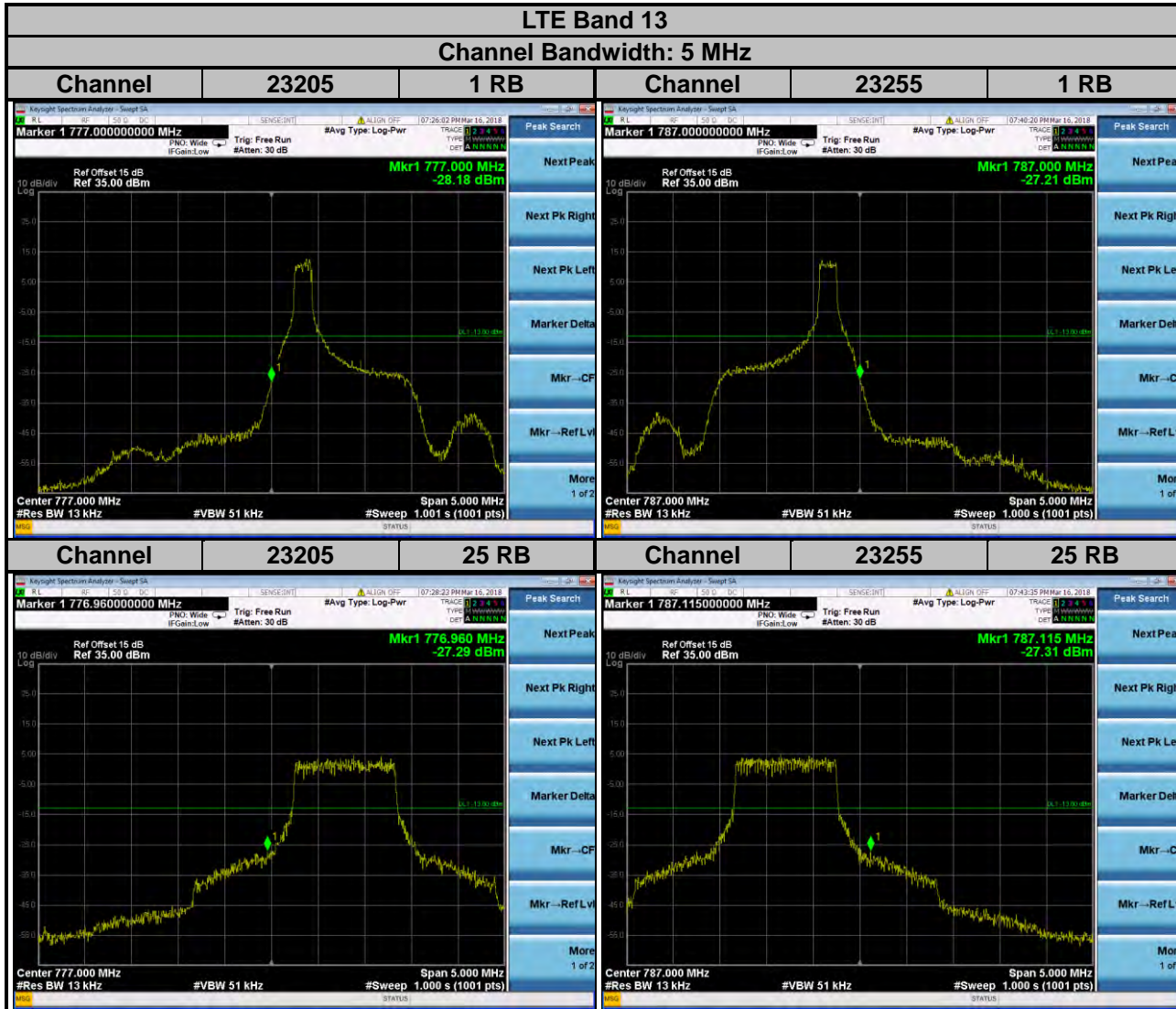

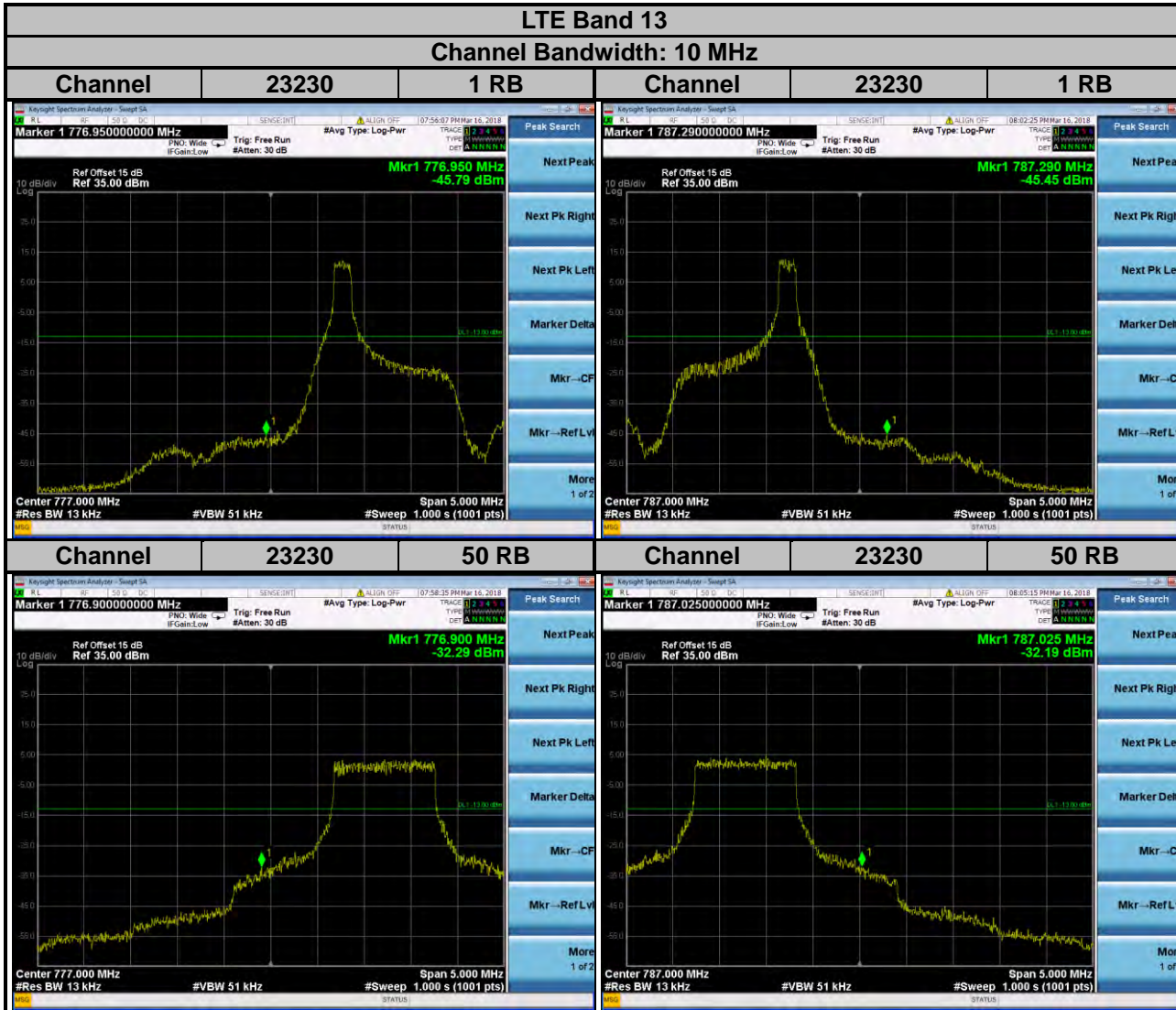

Emission Mask

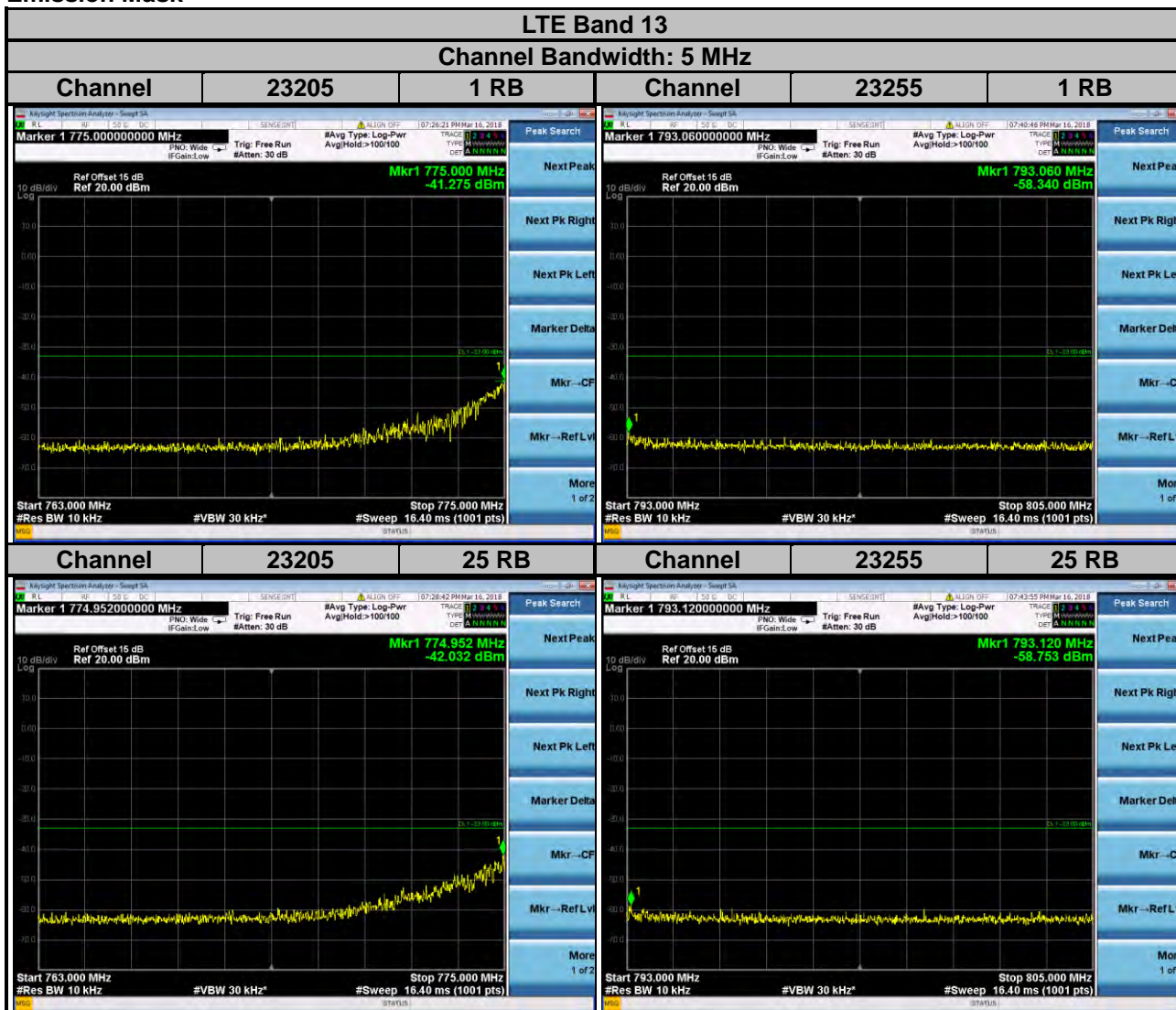

For the 763 - 775 MHz and 793 - 805 MHz band, the FCC limit is $65 + 10\log(P[\text{watt}])$ in a 6.25 kHz bandwidth. Since it was not possible to set the resolution bandwidth to 6.25 kHz with the available equipment, a bandwidth of 10 kHz was used instead to show compliance. By using a 10 kHz bandwidth on the spectrum analyzer.

$$10\log(10\text{kHz}/6.25\text{kHz}) = 2.04 \text{ dB}$$

$$\text{Limit line} = -35 \text{ dBm} + 2.04 \text{ dB} = -32.96 \text{ dBm}$$

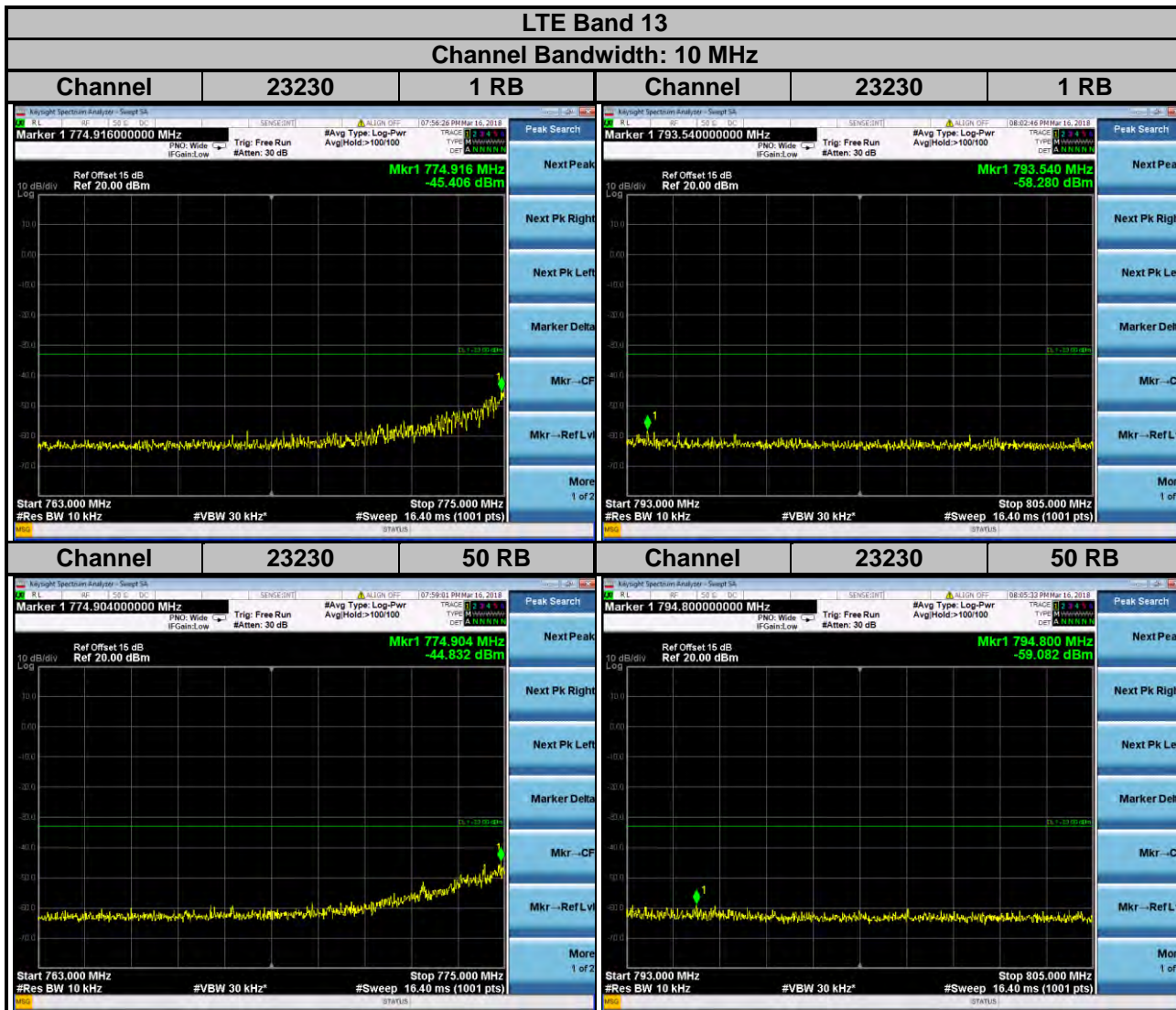

For the 763 - 775 MHz and 793 - 805 MHz band, the FCC limit is $65 + 10\log(P[\text{watt}])$ in a 6.25 kHz bandwidth. Since it was not possible to set the resolution bandwidth to 6.25 kHz with the available equipment, a bandwidth of 10 kHz was used instead to show compliance. By using a 10 kHz bandwidth on the spectrum analyzer.

$$10\log(10\text{kHz}/6.25\text{kHz}) = 2.04 \text{ dB}$$

$$\text{Limit line} = -35 \text{ dBm} + 2.04 \text{ dB} = -32.96 \text{ dBm}$$

4.5 Peak to Average Ratio

4.5.1 Limits of Peak to Average Ratio Measurement

In measuring transmissions in this band using an average power technique, the peak to-average ratio (PAR) of the transmission may not exceed 13 dB.

4.5.2 Test Setup

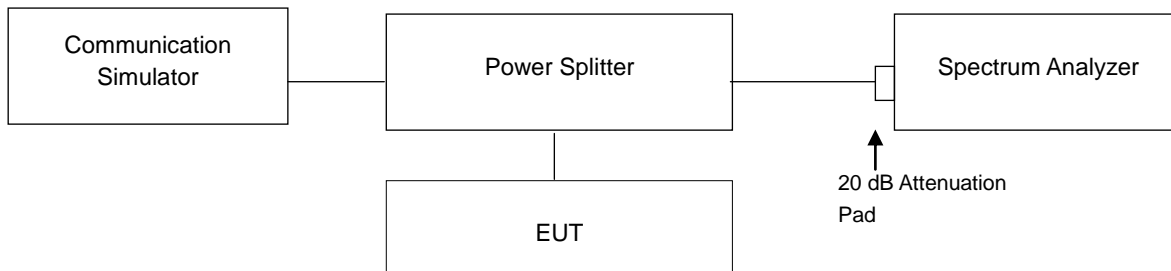

4.5.3 Test Procedures

1. Set resolution/measurement bandwidth \geq signal's occupied bandwidth;
2. Set the number of counts to a value that stabilizes the measured CCDF curve;
3. Record the maximum PAPR level associated with a probability of 0.1 %.

4.5.4 Test Results

LTE Band 4							
Channel Bandwidth: 5 MHz				Channel Bandwidth: 10 MHz			
Channel	Frequency (MHz)	Peak to Average Ratio (dB)		Channel	Frequency (MHz)	Peak to Average Ratio (dB)	
		QPSK	16QAM			QPSK	16QAM
19975	1712.5	3.69	3.92	20000	1715.0	3.66	4.01
20175	1732.5	3.67	3.99	20175	1732.5	3.65	4.00
20375	1752.5	3.74	4.00	20350	1750.0	3.73	4.11

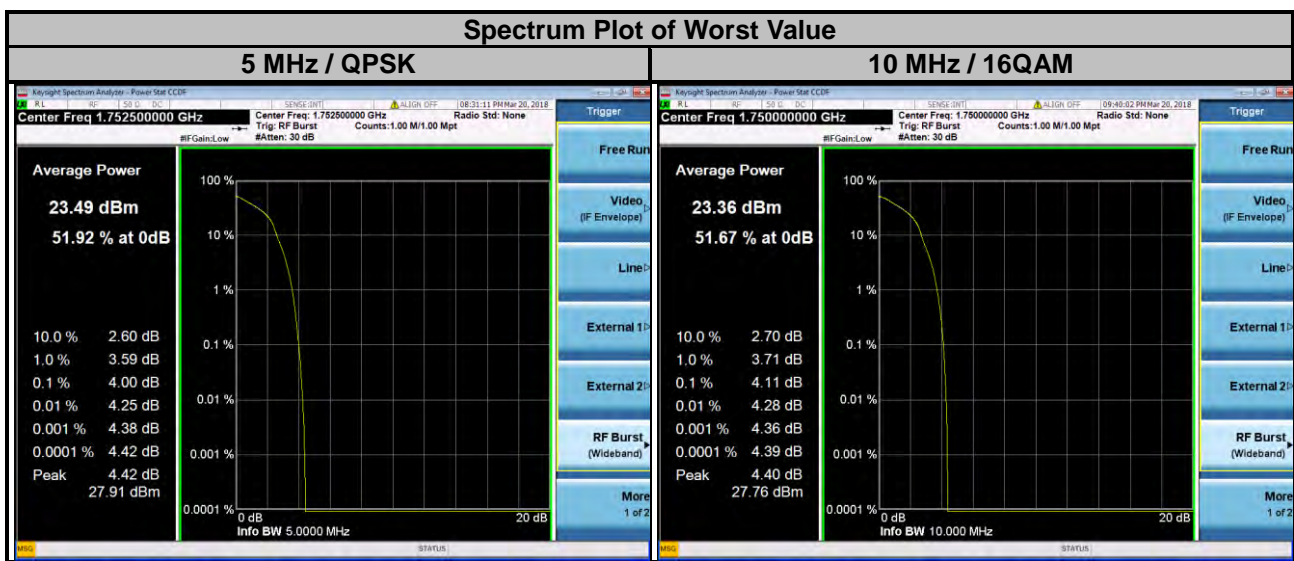

LTE Band 4							
Channel Bandwidth: 15 MHz				Channel Bandwidth: 20 MHz			
Channel	Frequency (MHz)	Peak to Average Ratio (dB)		Channel	Frequency (MHz)	Peak to Average Ratio (dB)	
		QPSK	16QAM			QPSK	16QAM
20025	1717.5	3.67	4.47	20050	1720.0	3.62	4.32
20175	1732.5	3.75	4.34	20175	1732.5	3.66	4.43
20325	1747.5	3.66	4.48	20300	1745.0	3.66	4.27

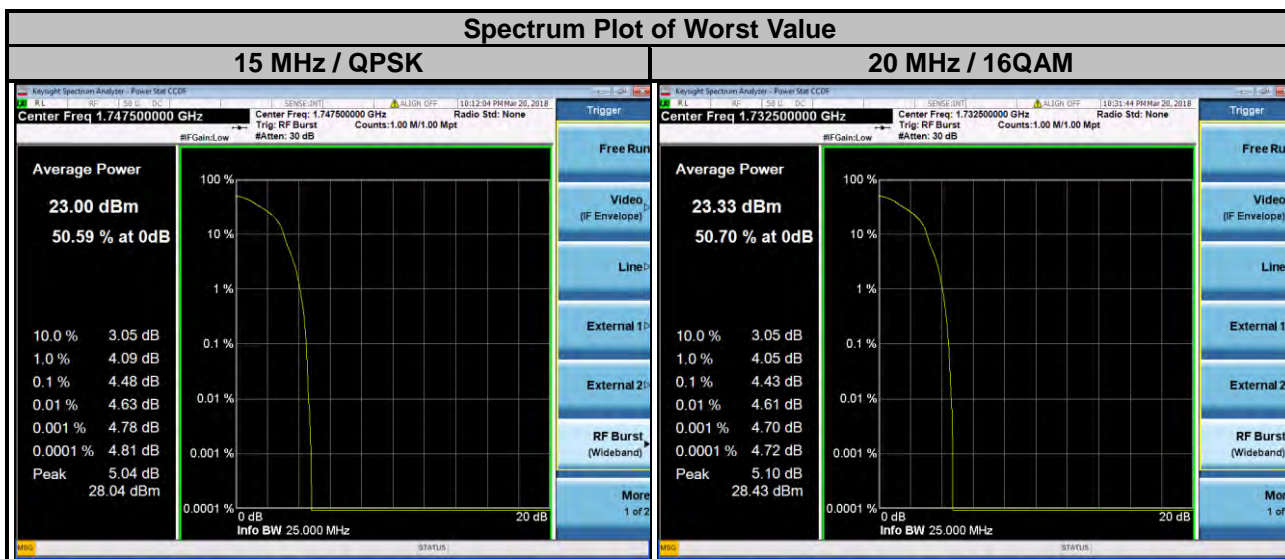

LTE Band 13

Channel Bandwidth: 5 MHz				Channel Bandwidth: 10 MHz			
Channel	Frequency (MHz)	Peak to Average Ratio (dB)		Channel	Frequency (MHz)	Peak to Average Ratio (dB)	
		QPSK	16QAM			QPSK	16QAM
23205	779.5	3.57	3.76	23230	782.0	3.46	3.89
23230	782.0	3.54	3.92				
23255	784.5	3.56	3.86				

Spectrum Plot of Worst Value

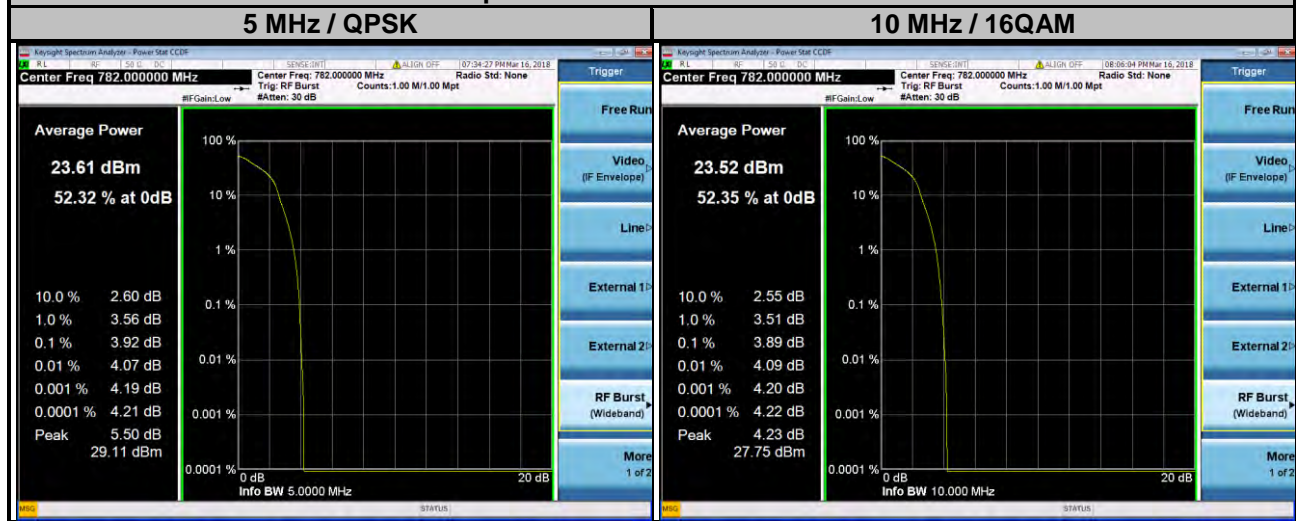

4.6 Conducted Spurious Emissions

4.6.1 Limits of Conducted Spurious Emissions Measurement

The power of any emission outside a licensee's frequency block shall be attenuated below the transmitter power (P) by at least $43 + 10 \log_{10}(P)$ dB. The limit of emission is equal to -13 dBm.

4.6.2 Test Setup

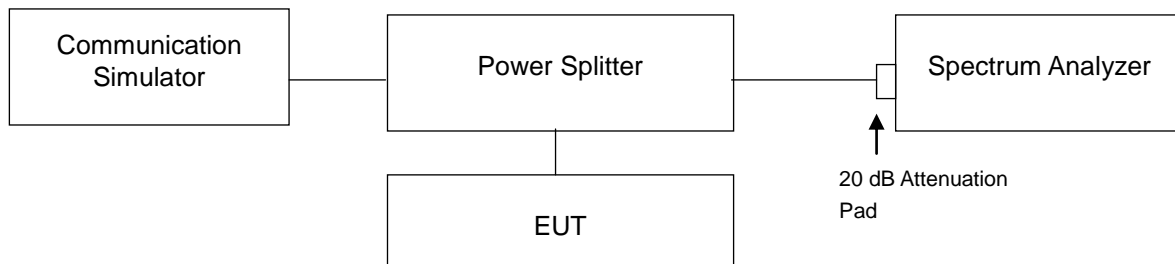

4.6.3 Test Procedure

- The EUT makes a phone call to the communication simulator. All measurements were done at low, middle and high operational frequency range.
- Measuring frequency range is from 30 MHz to 26.5 GHz. 10 dB attenuation pad is connected with spectrum. RBW = 1 MHz and VBW = 3 MHz are used for conducted emission measurement.

4.6.4 Test Results

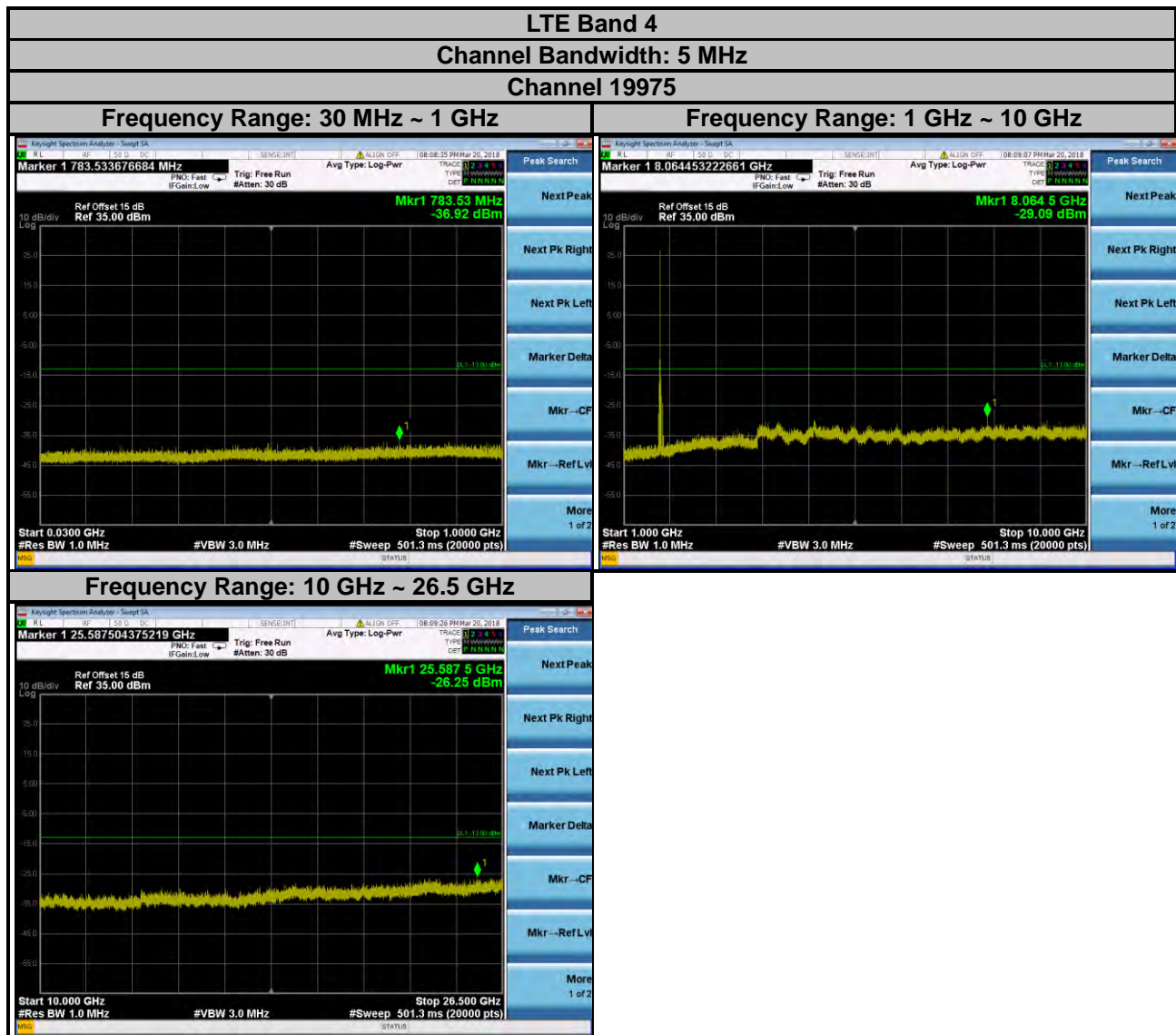

LTE Band 4
Channel Bandwidth: 5 MHz
Channel 20175

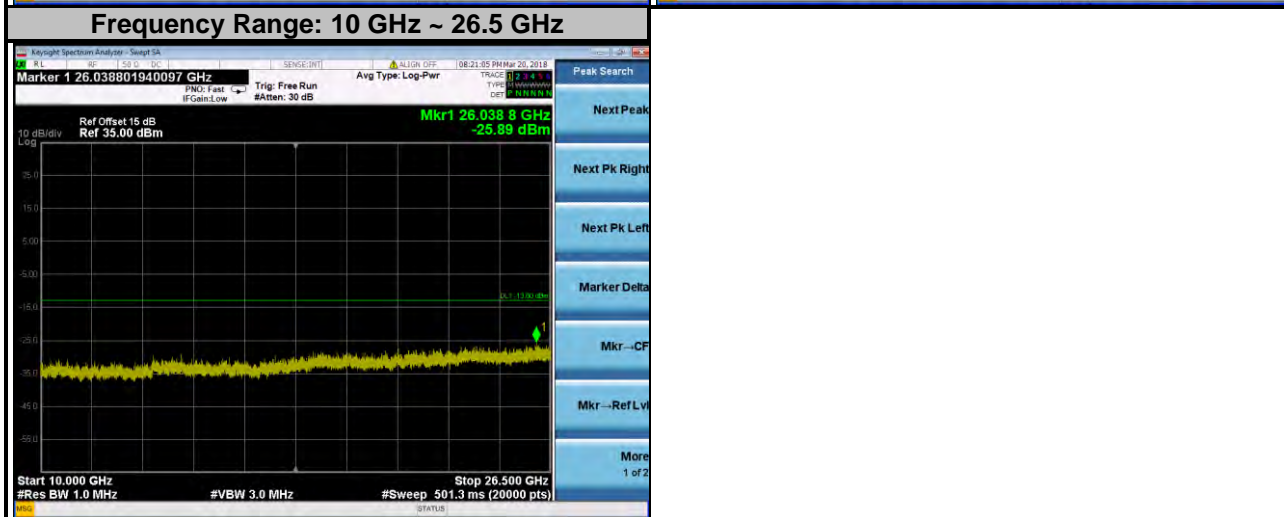
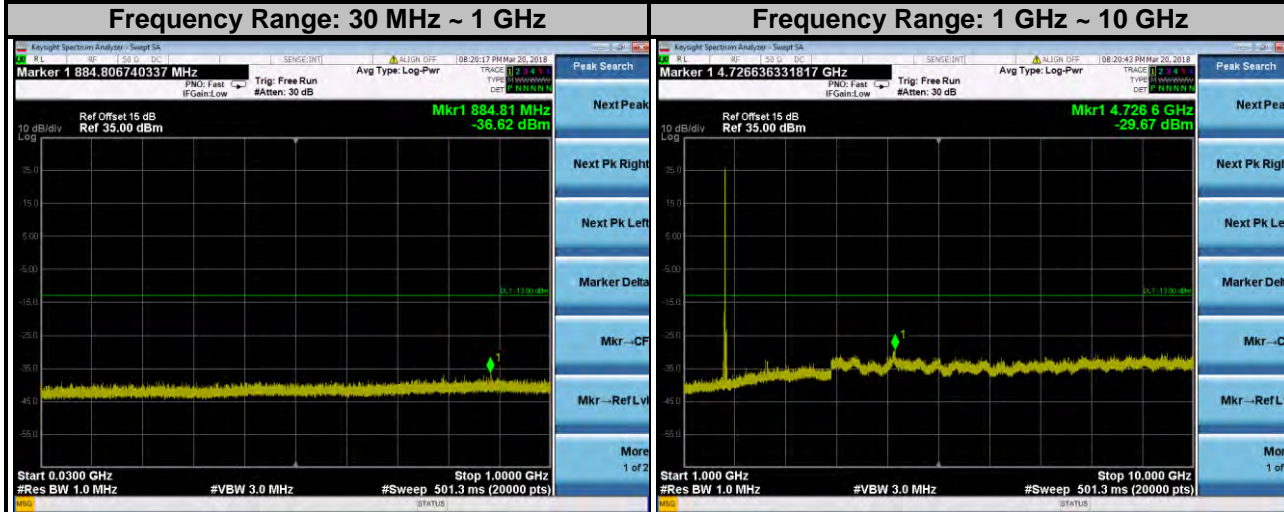

LTE Band 4
Channel Bandwidth: 5 MHz
Channel 20375

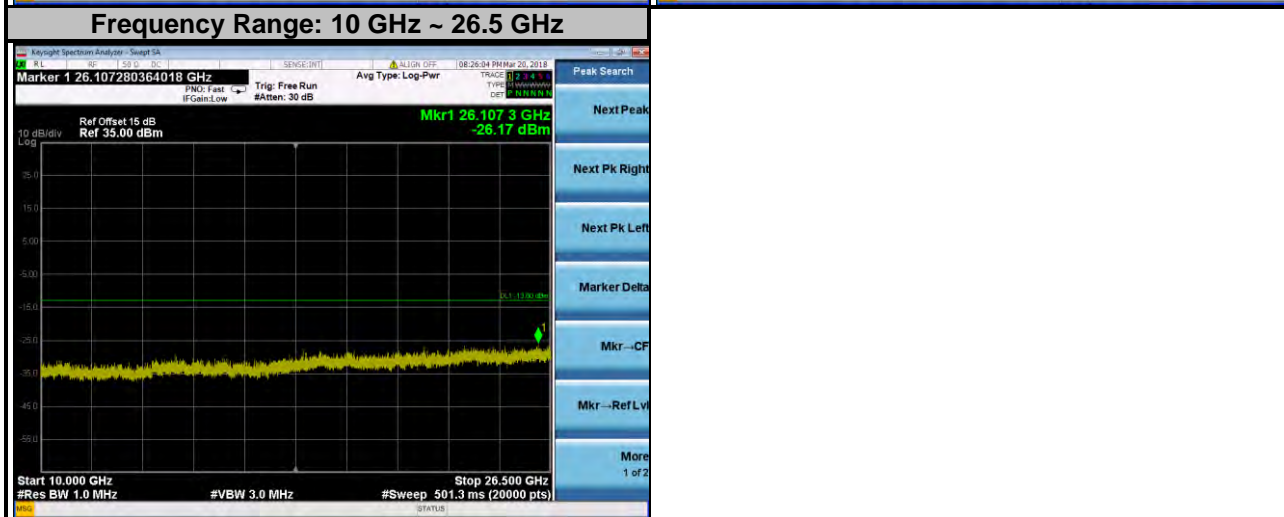
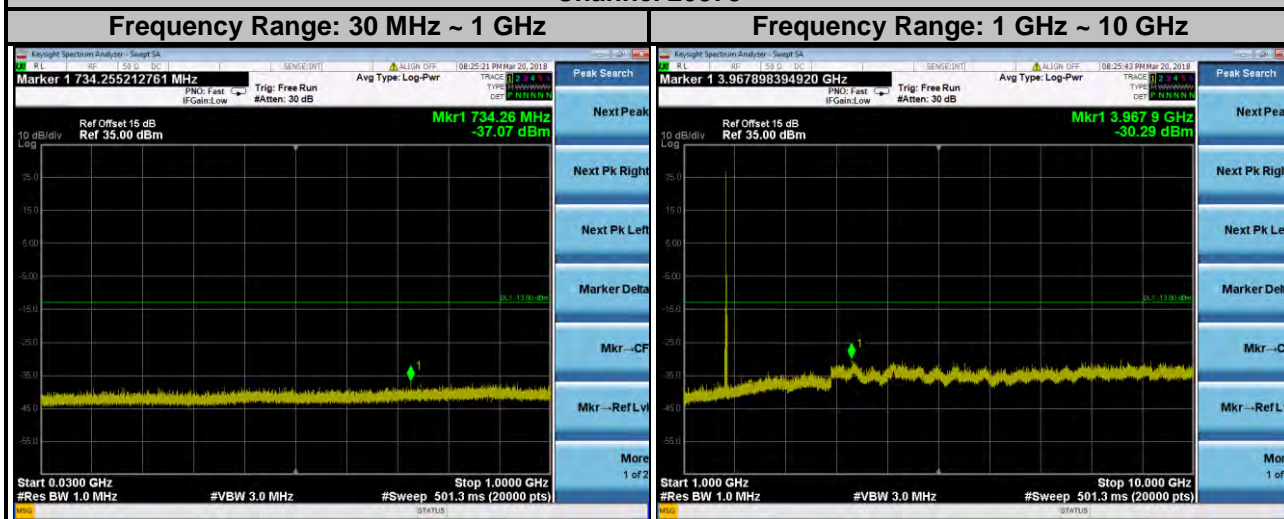

LTE Band 4
Channel Bandwidth: 10 MHz
Channel 20000

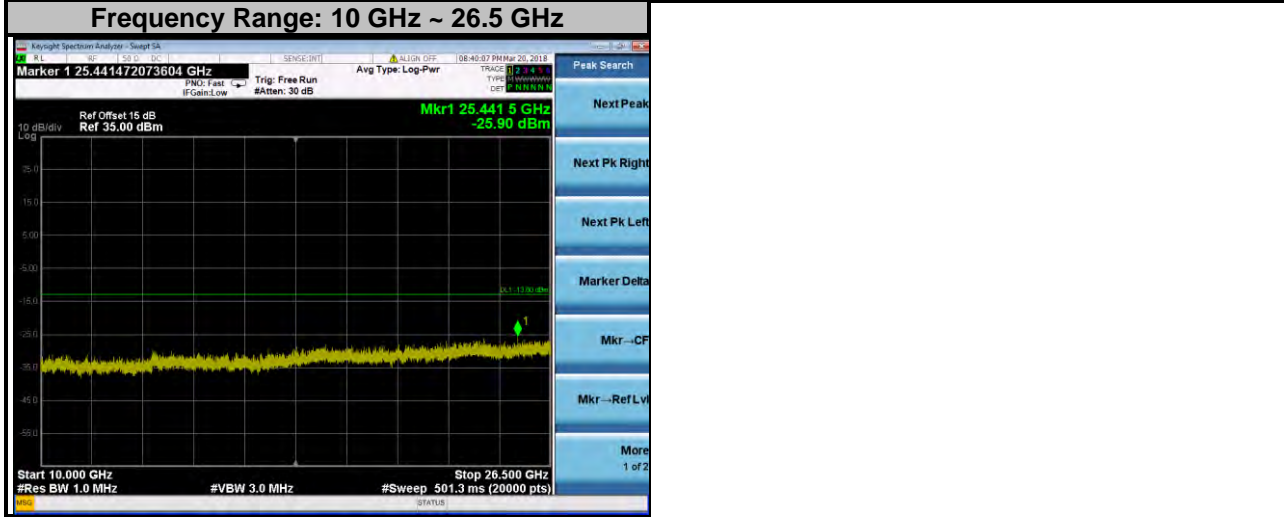
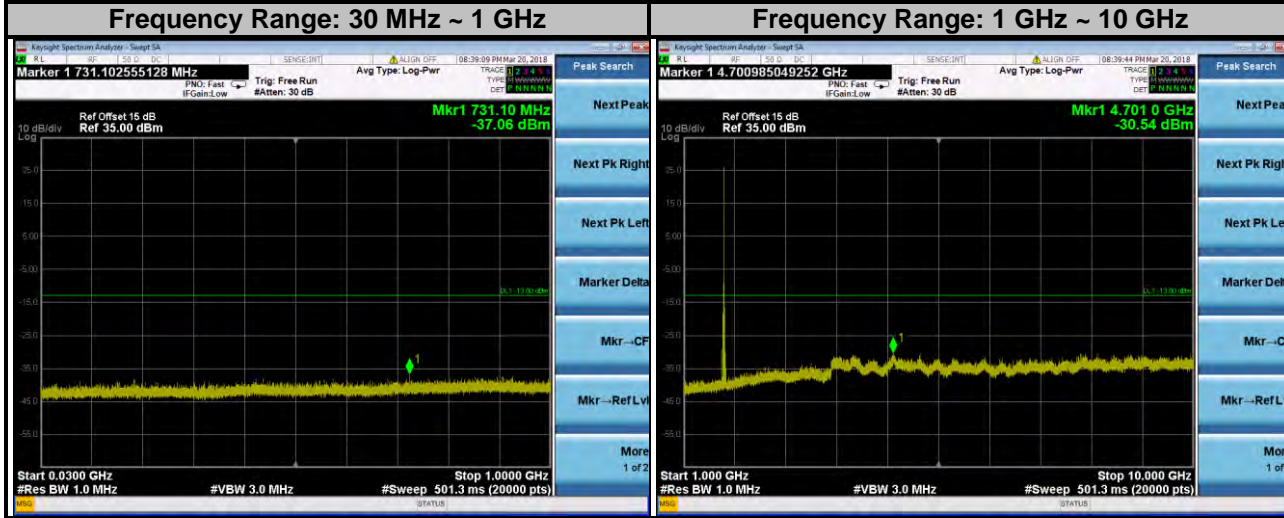

LTE Band 4
Channel Bandwidth: 10 MHz
Channel 20175

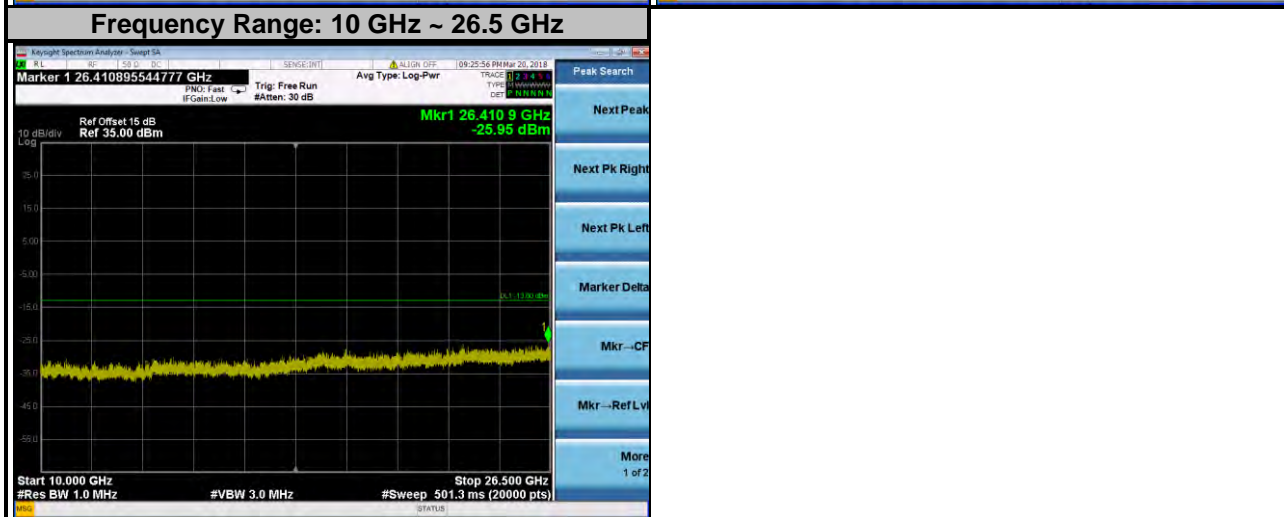
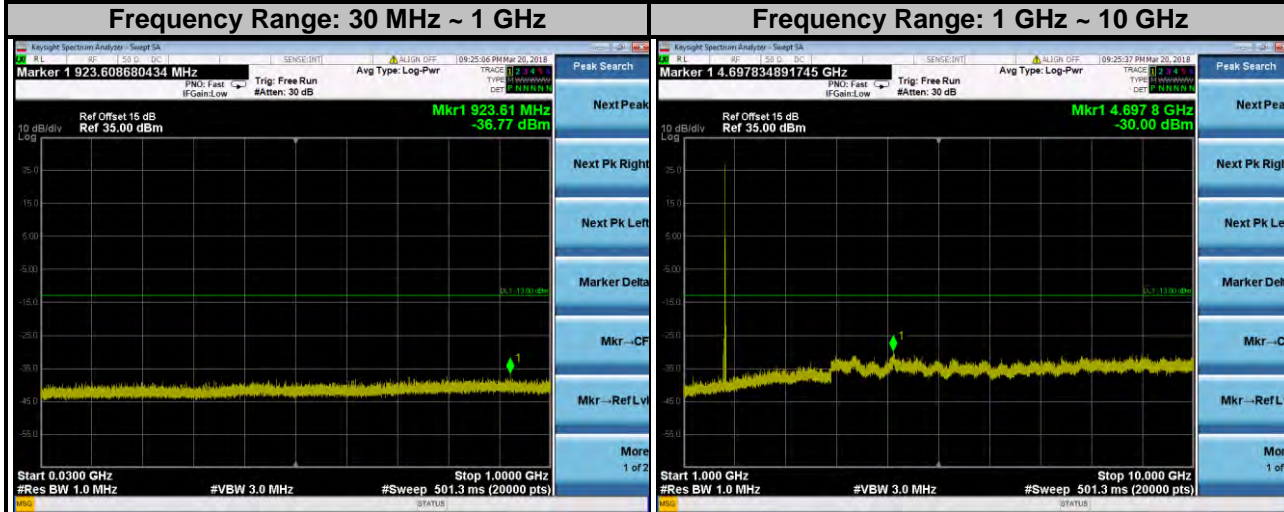

LTE Band 4
Channel Bandwidth: 10 MHz
Channel 20350

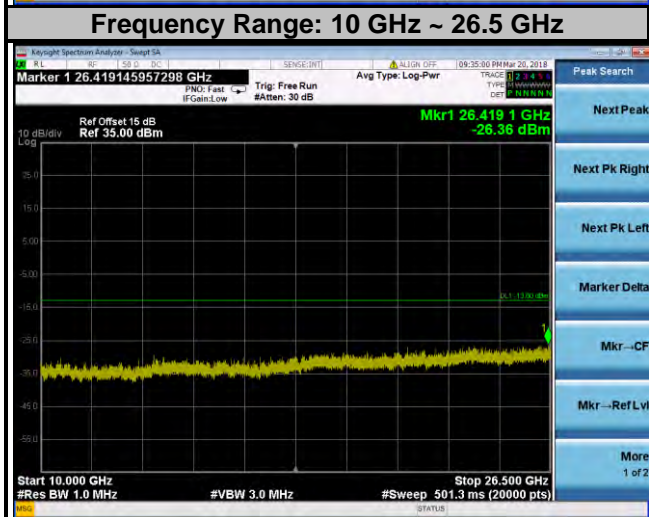
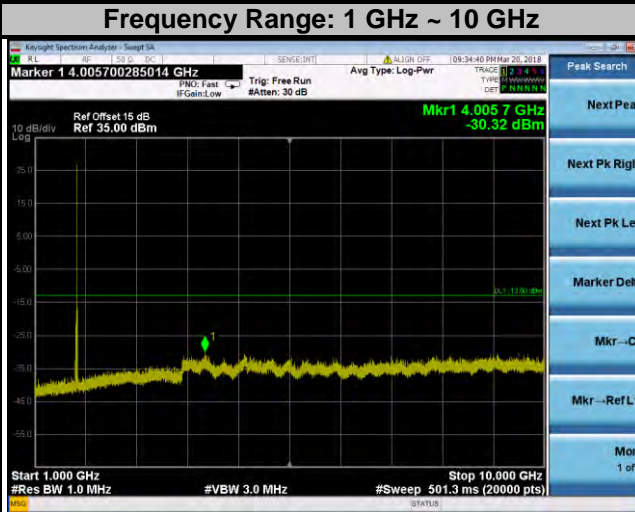
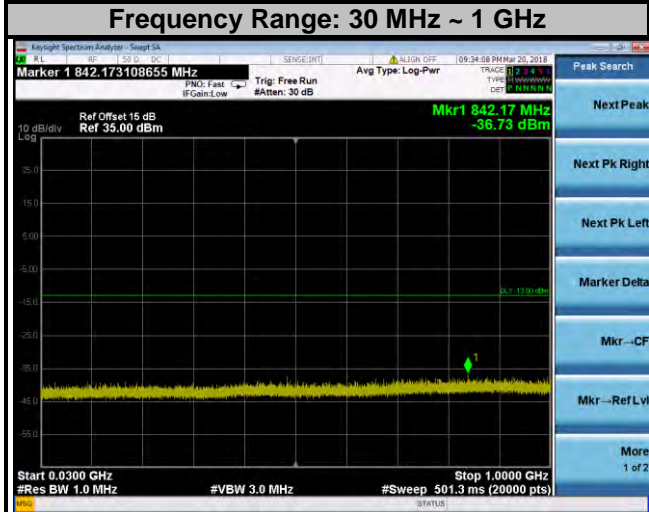

LTE Band 4
Channel Bandwidth: 15 MHz
Channel 20025

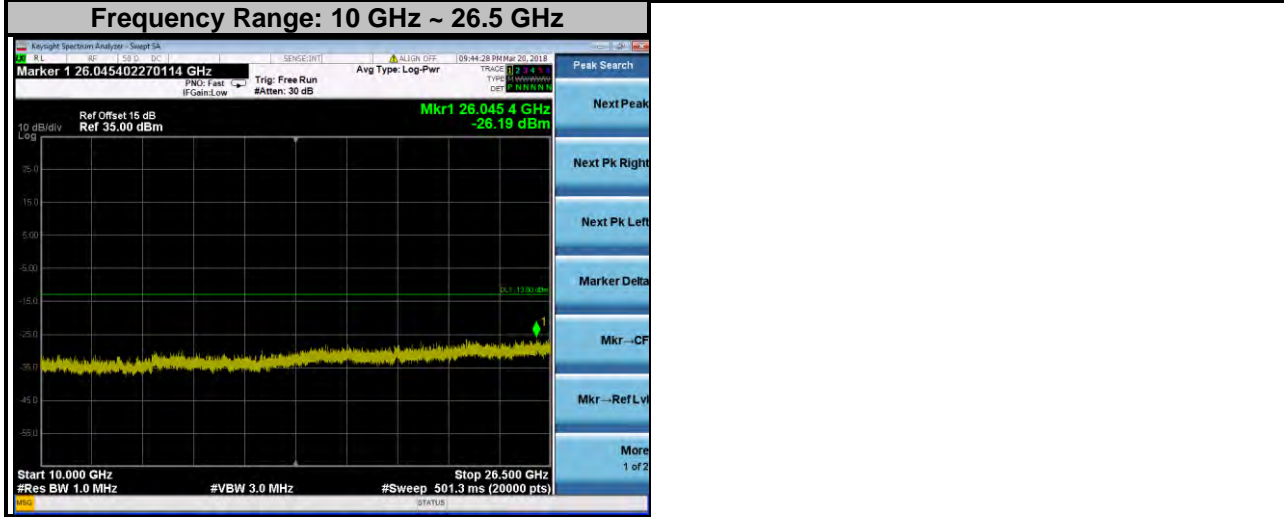
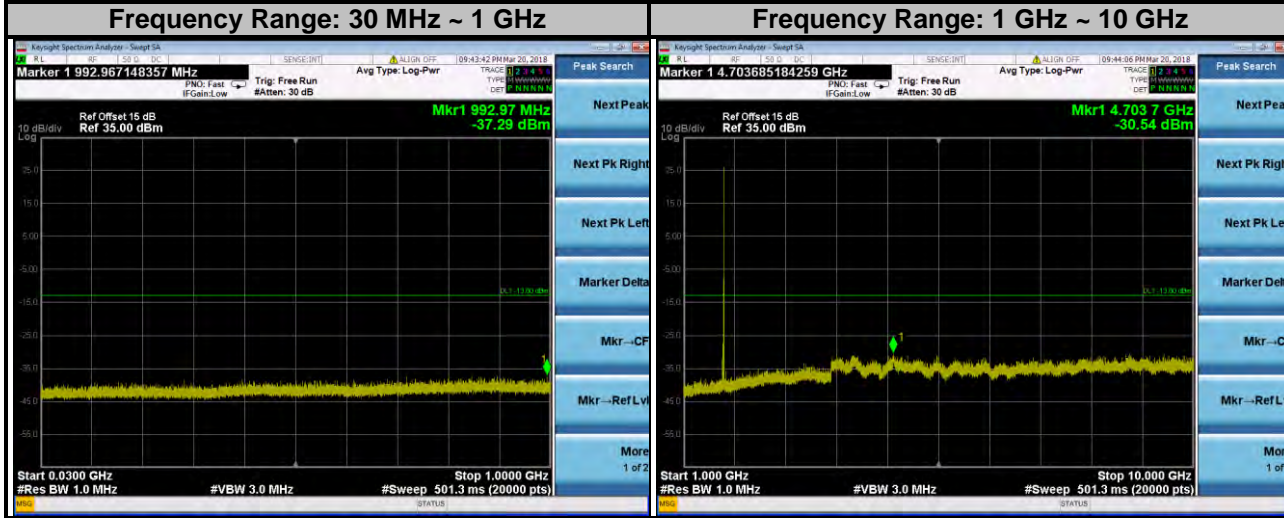

LTE Band 4
Channel Bandwidth: 15 MHz
Channel 20175

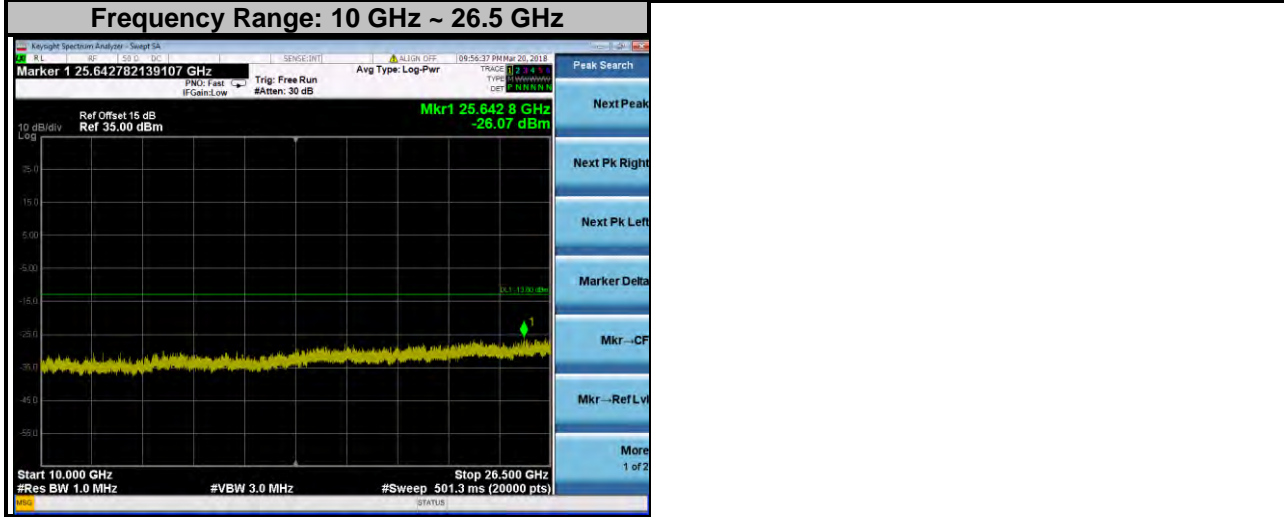
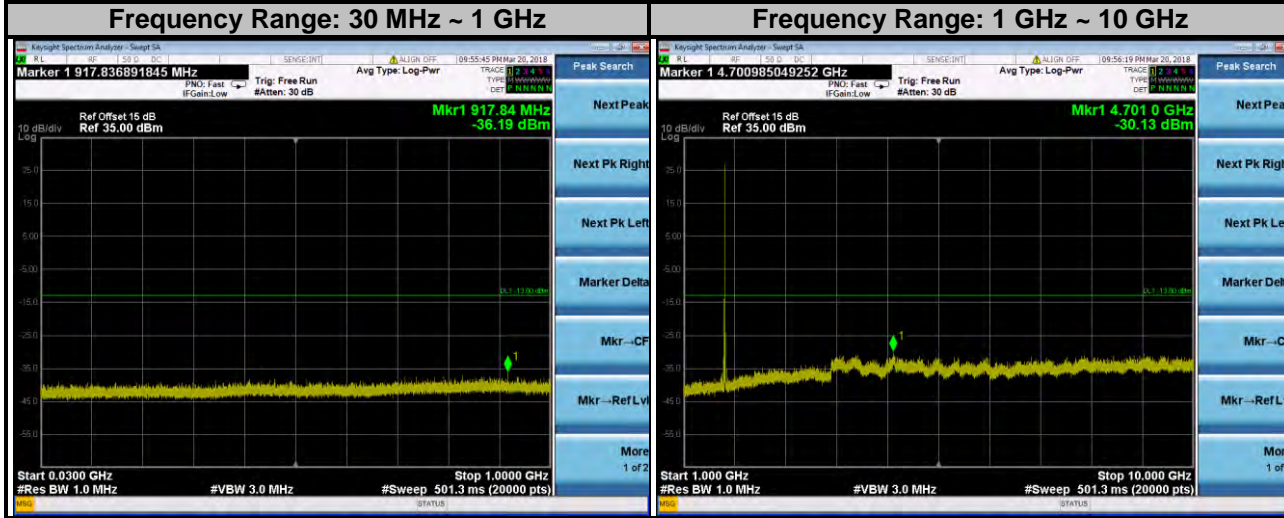

LTE Band 4
Channel Bandwidth: 15 MHz
Channel 20325

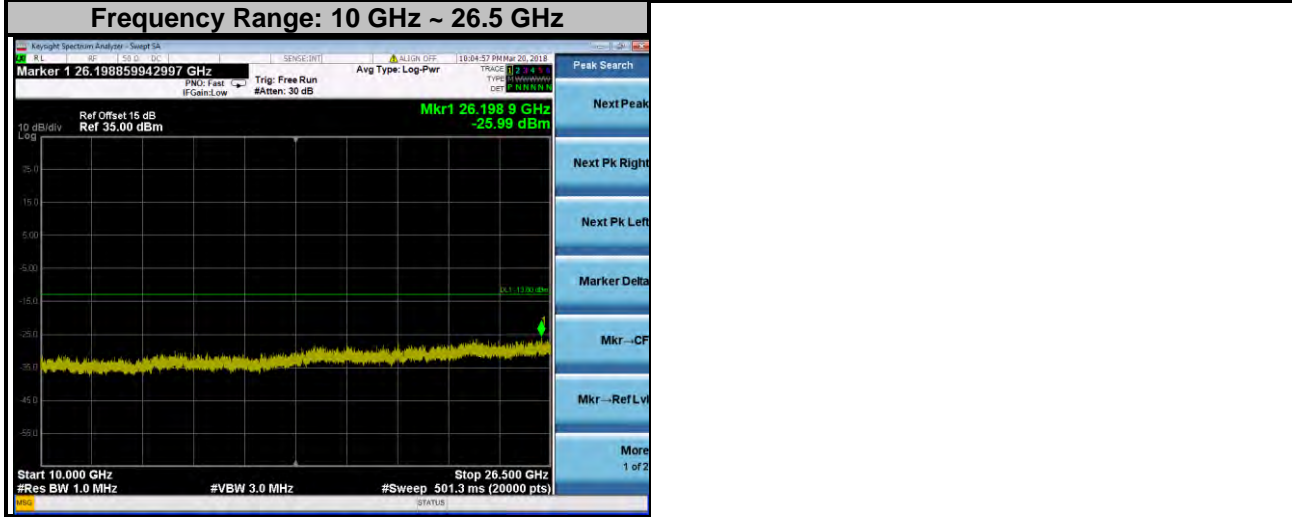
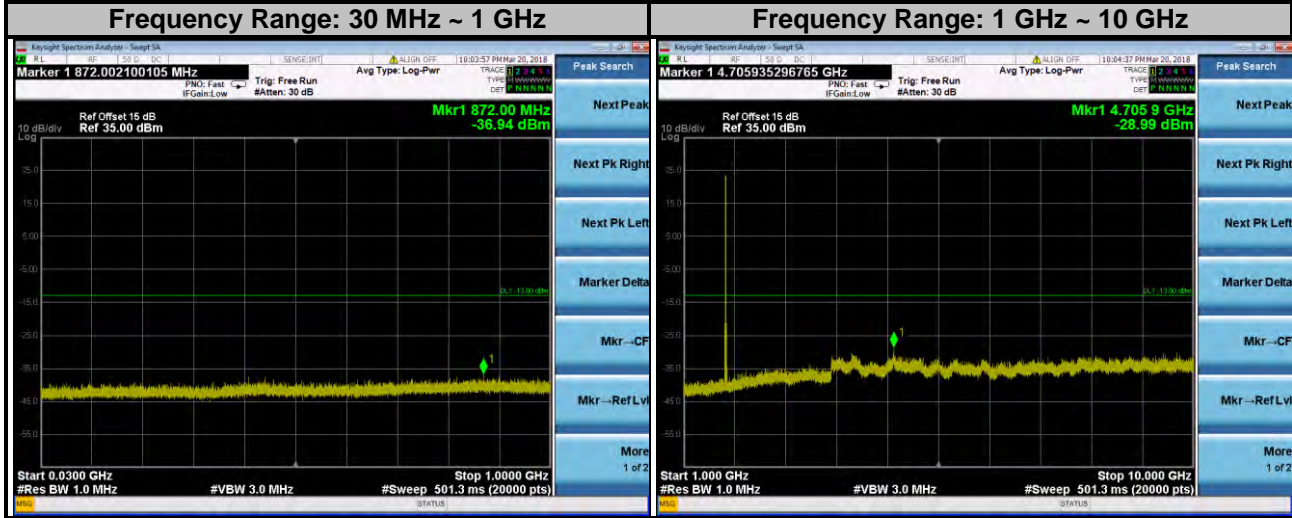

LTE Band 4
Channel Bandwidth: 20 MHz
Channel 20050

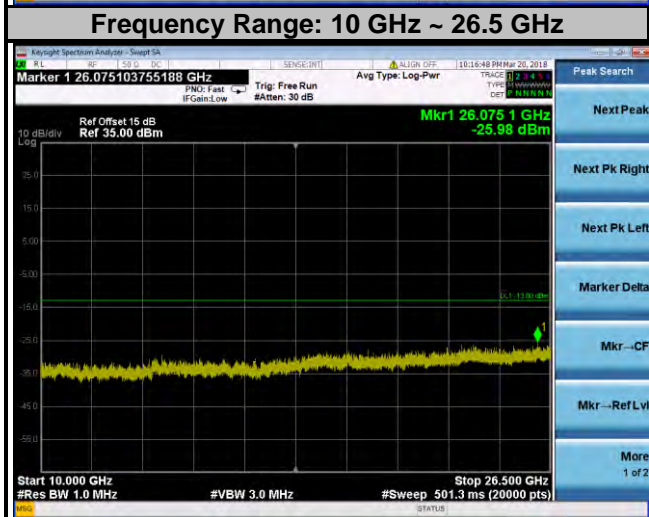
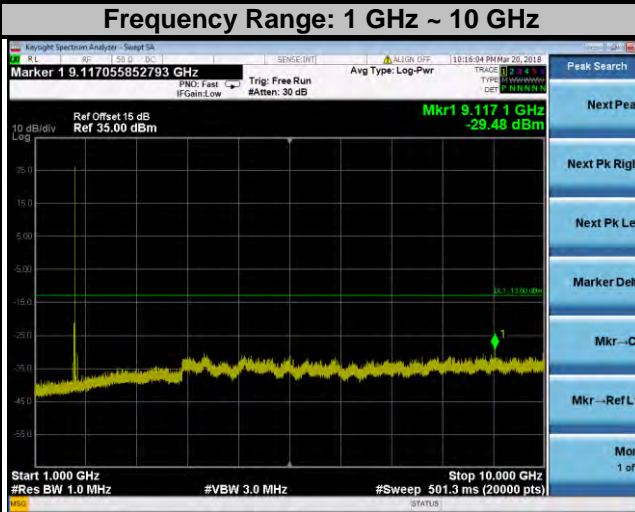
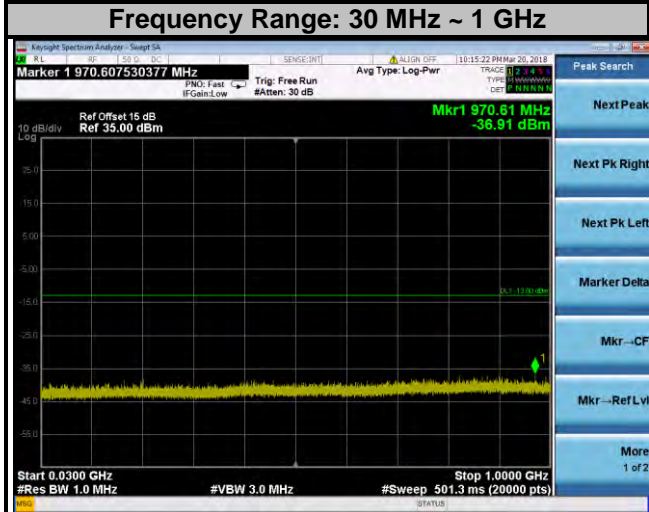

LTE Band 4
Channel Bandwidth: 20 MHz
Channel 20175

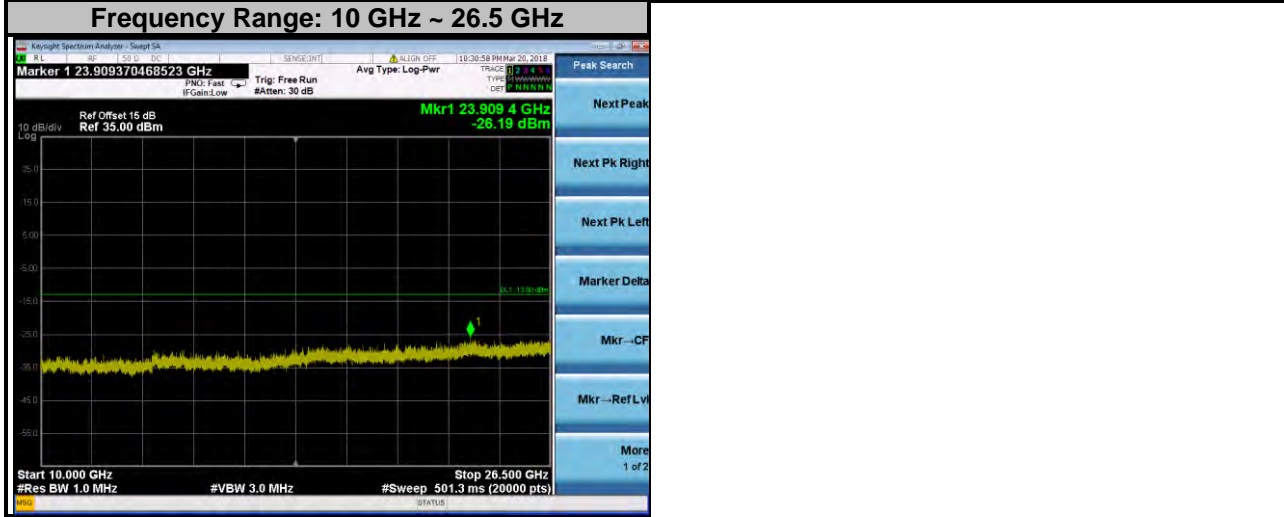
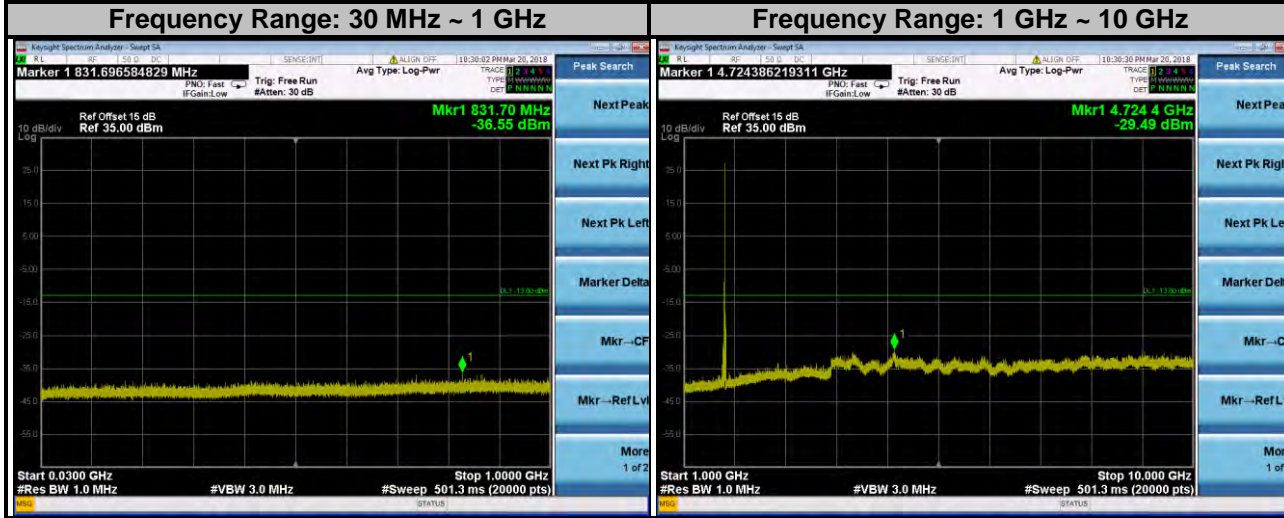

LTE Band 4
Channel Bandwidth: 20 MHz
Channel 20300

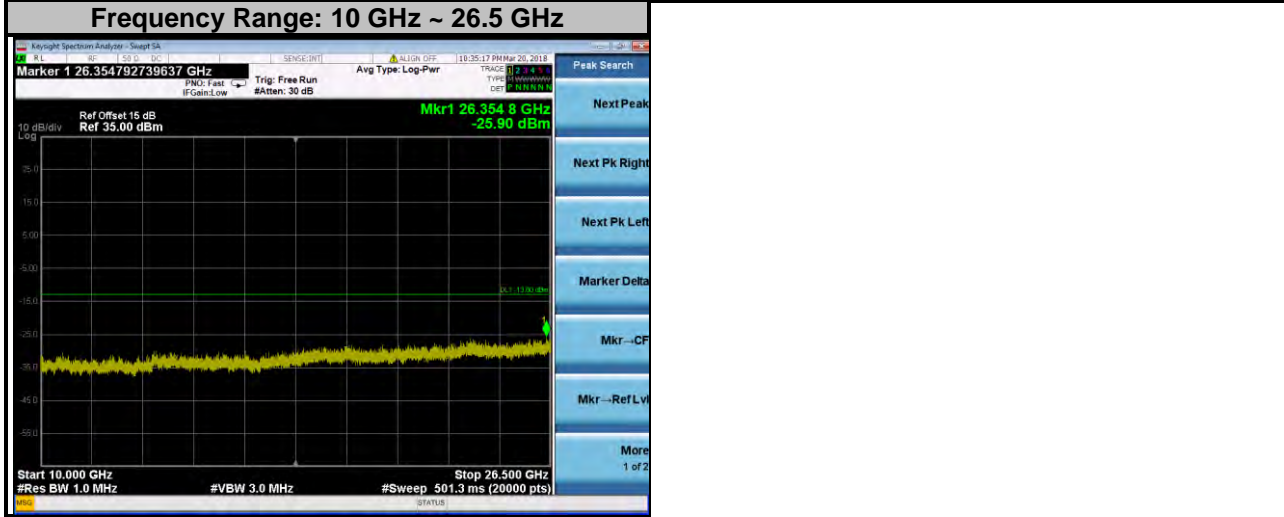
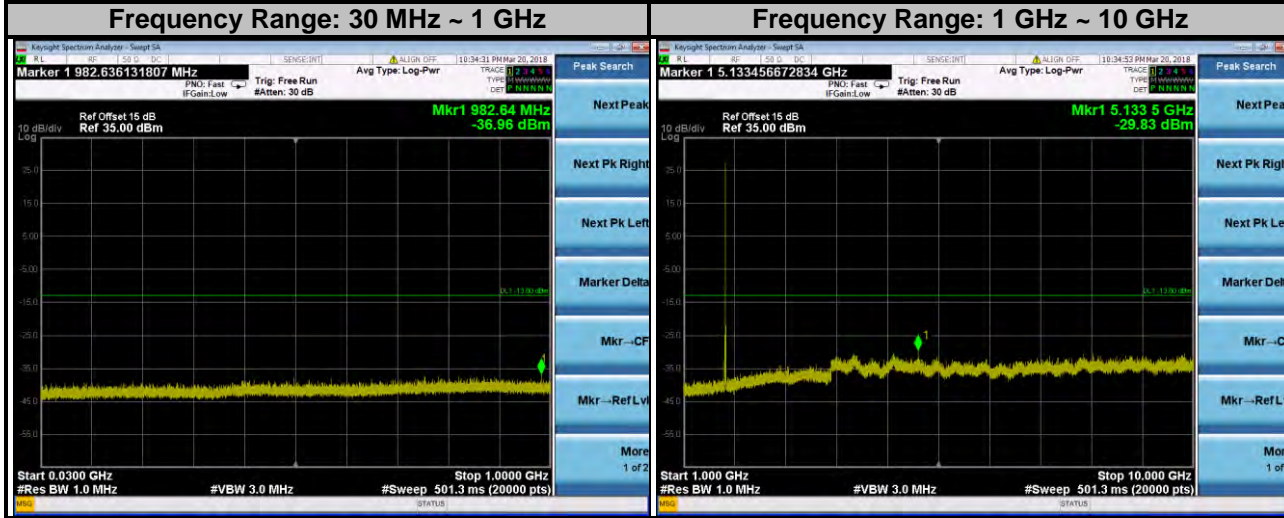

LTE Band 13
Channel Bandwidth: 5 MHz
Channel 23205

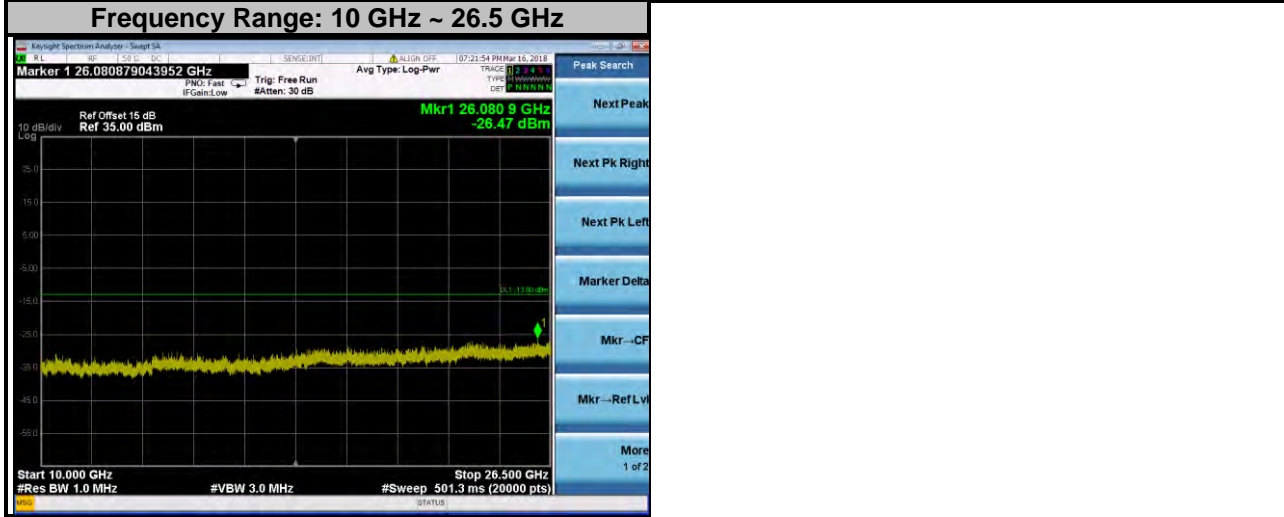
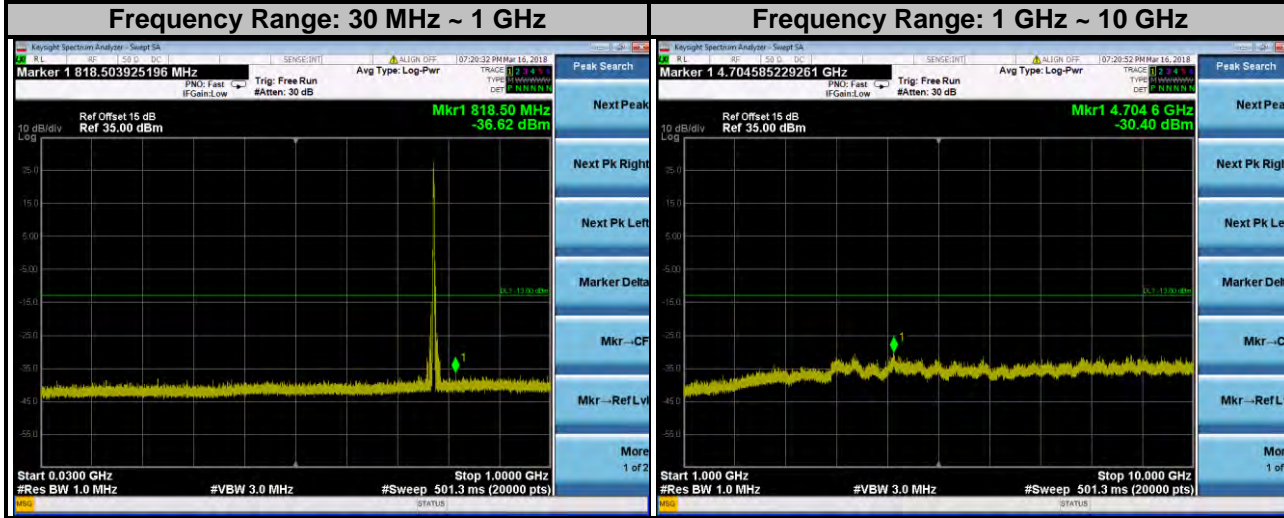

LTE Band 13
Channel Bandwidth: 5 MHz
Channel 23230

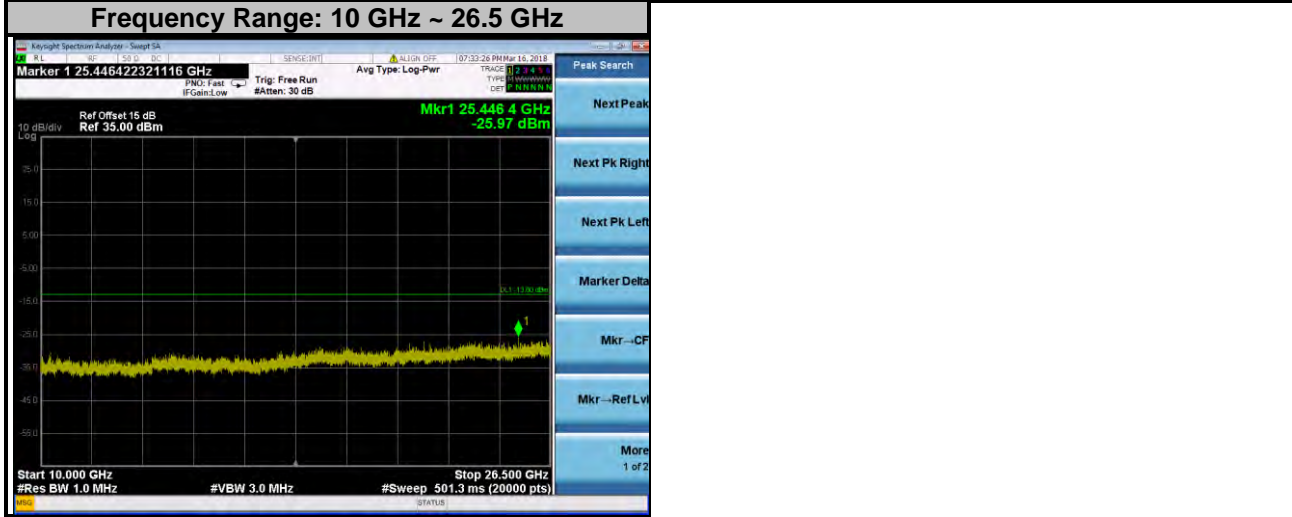
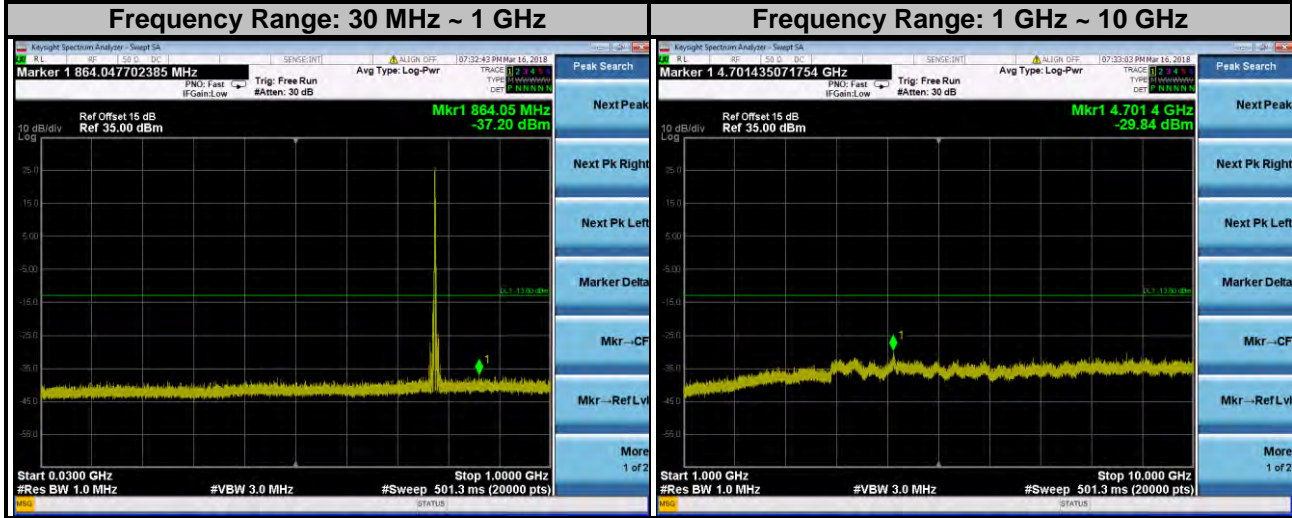

LTE Band 13
Channel Bandwidth: 5 MHz
Channel 23255

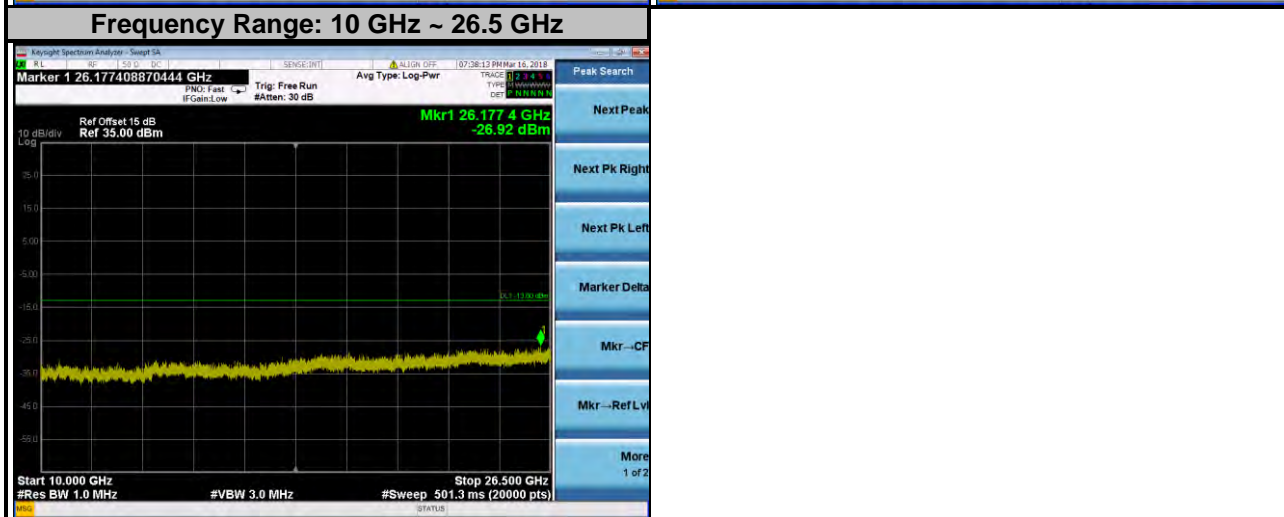
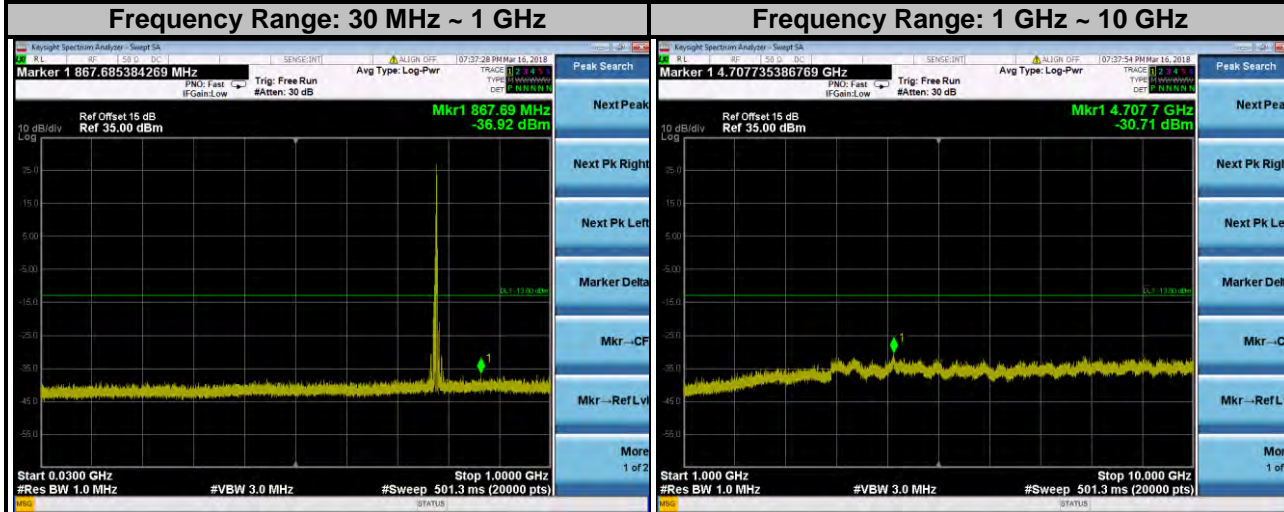

LTE Band 13
Channel Bandwidth: 10 MHz
Channel 23230

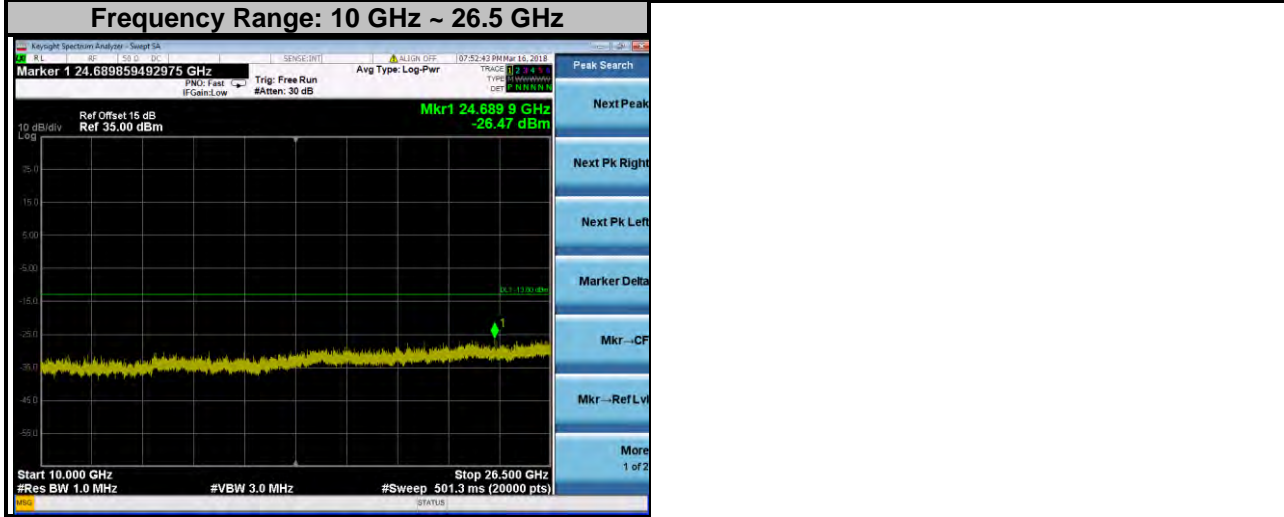
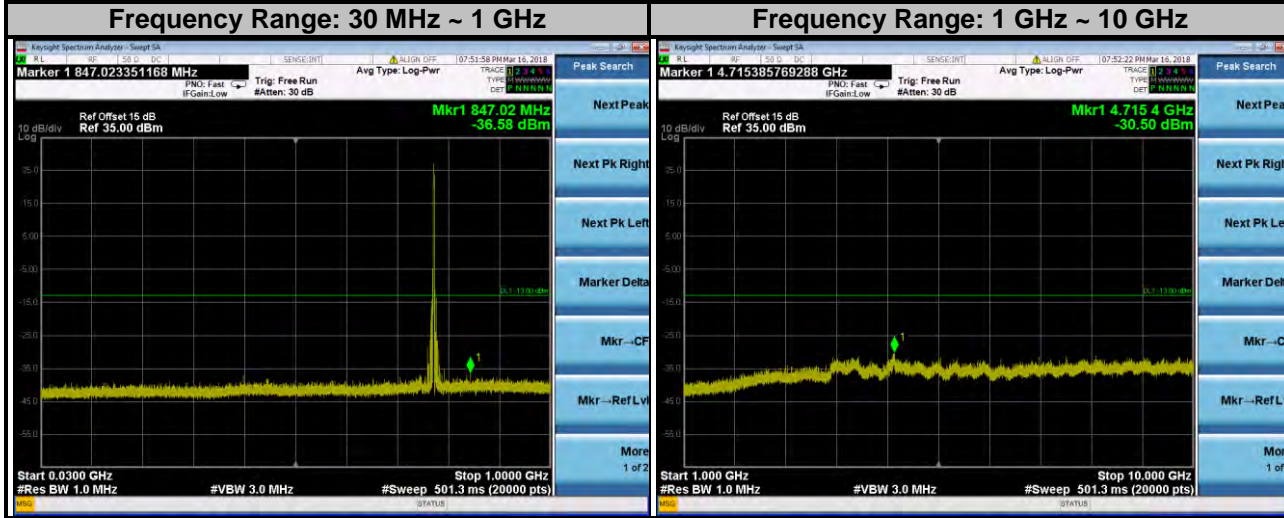

4.7 Radiated Emission Measurement

4.7.1 Limits of Radiated Emission Measurement

- a. The power of any emission outside a licensee's frequency block shall be attenuated below the transmitter power (P) by at least $43 + 10 \log_{10}(P)$ dB. The limit of emission is equal to -13 dBm.
- b. For operations in the 775-788 MHz, emissions in the band 1559-1610 MHz shall be limited to -70 dBW/MHz. The limit of emissions is equal to -40 dBm.

4.7.2 Test Procedure

- a. Substitution method is used for E.I.R.P measurement. In the semi-anechoic chamber, EUT placed on the 0.8 m (below or equal 1 GHz) and/or 1.5 m (above 1 GHz) height of Turn Table, rotated the table around 360 degrees to search the maximum radiation power and receiver antenna shall be rotated vertical and horizontal polarization and moved height from 1 m to 4 m to find the maximum polar radiated power. The "Read Value" is the spectrum reading the maximum power value.
- b. The substitution horn antenna is substituted for EUT at the same position and signals generator export the CW signal to the substitution antenna via a TX cable. Rotated the Turn Table and moved receiving antenna to find the maximum radiation power. Adjust output power level of S.G to get a Value of spectrum reading equal to "Read Value" of step a. Record the power level of S.G.
- c. $EIRP = \text{Output power level of S.G} - \text{TX cable loss} + \text{Antenna gain of substitution horn}$.
- d. E.R.P power can be calculated form E.I.R.P power by subtracting the gain of dipole, $E.R.P \text{ power} = E.I.P.R \text{ power} - 2.15 \text{ dBi}$.

Note: The resolution bandwidth of spectrum analyzer is 1 MHz and the video bandwidth is 3 MHz.

4.7.3 Deviation from Test Standard

No deviation.

4.7.4 Test Setup

<Radiated Emission below or equal 1 GHz>

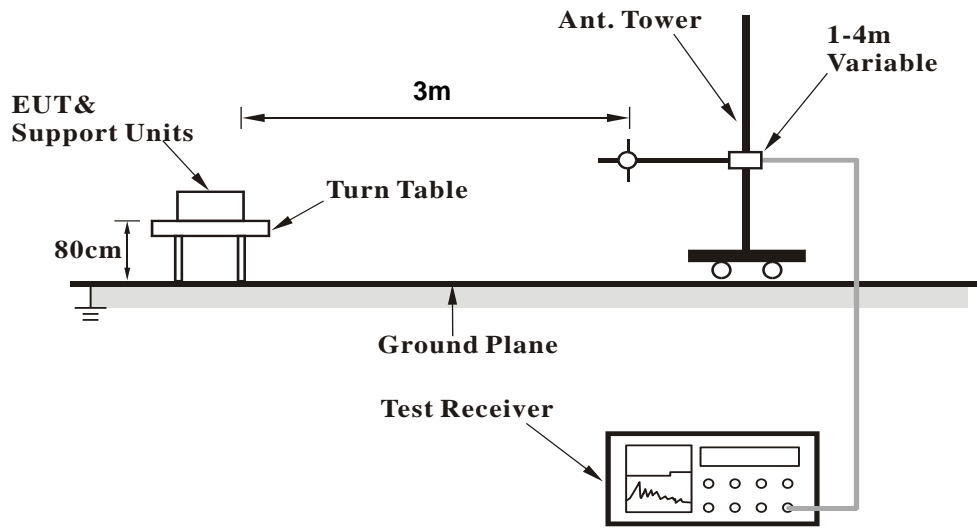

<Radiated Emission above 1 GHz>

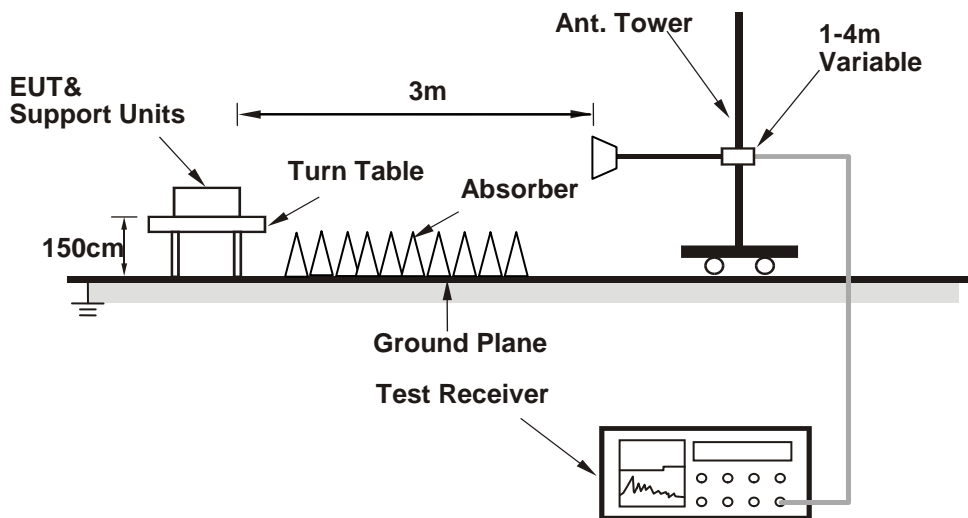

For the actual test configuration, please refer to the attached file (Test Setup Photo).

4.7.5 Test Results

LTE Band 4

Channel Bandwidth: 5 MHz / QPSK

Low Channel



Bureau Veritas Consumer Products Services Ltd., Taoyuan Branch

A D T

Data: 3

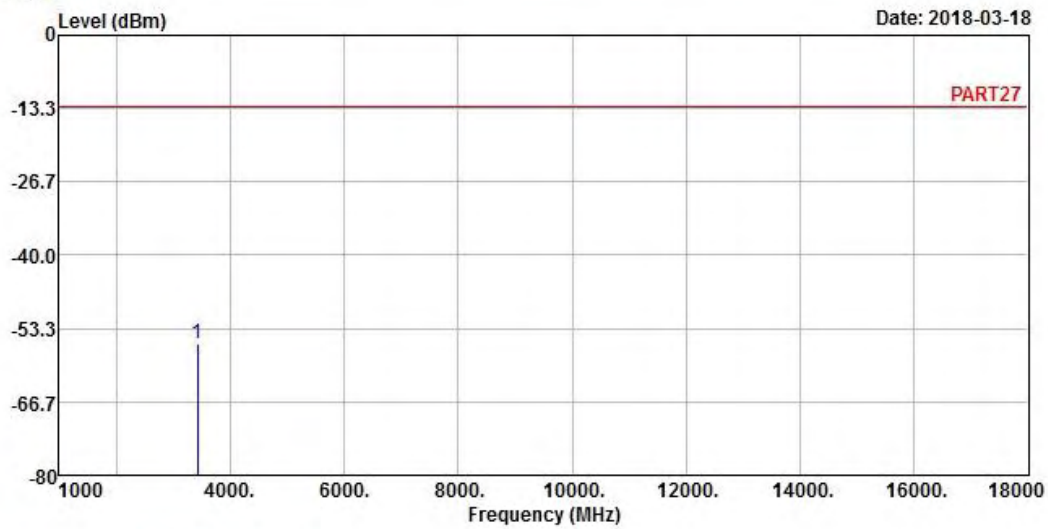

Site : 966 Chamber 5
 Condition: PART27 HORIZONTAL
 Remak : CAT_M1 Band 4 QPSK_5M Link_L-CH
 Tested by: Jisyong Wang

	Read	Limit	Over		
Freq	Level	Level	Line	Limit	Factor Remark
MHz	dBm	dBm	dBm	dB	dB
1 pp 3425.00	-56.13	-47.04	-13.00	-43.13	-9.09 Peak



Bureau Veritas Consumer Products Services Ltd., Taoyuan Branch

A D T

Data: 4

Date: 2018-03-18

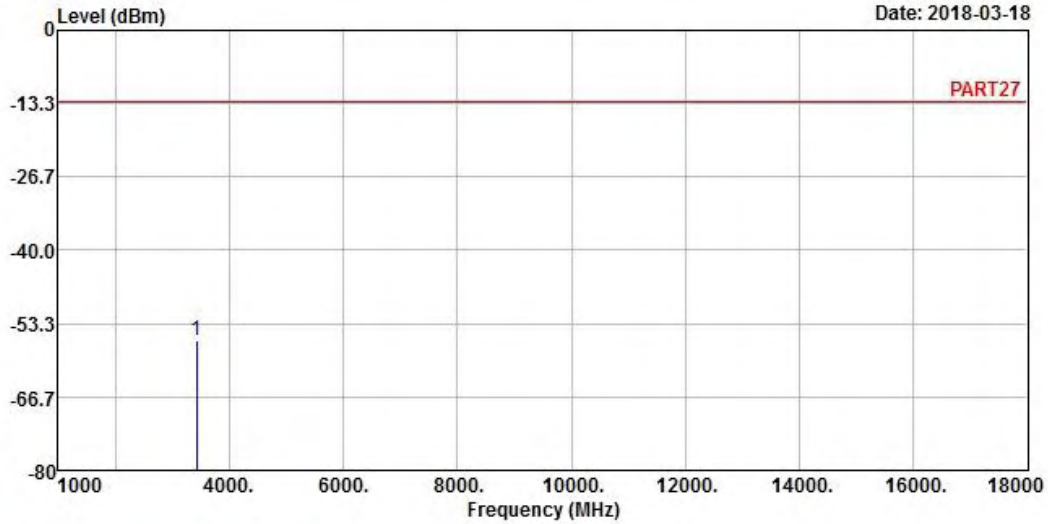

Site : 966 Chamber 5
 Condition: PART27 VERTICAL
 Remak : CAT_M1 Band 4 QPSK_5M Link_L-CH
 Tested by: Jisyong Wang

Freq	Level	Read Level	Limit Line	Over Limit	Factor	Remark
MHz	dBm	dBm	dBm	dB	dB	
1 pp 3425.00	-56.48	-47.39	-13.00	-43.48	-9.09	Peak

Middle Channel



Bureau Veritas Consumer Products Services Ltd., Taoyuan Branch

A D T

Data: 3

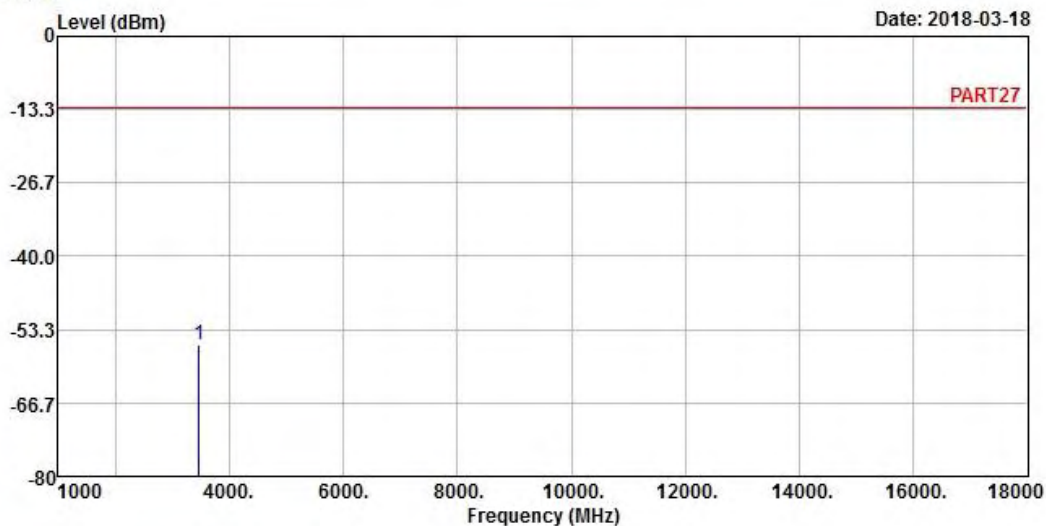

Site : 966 Chamber 5
 Condition: PART27 VERTICAL
 Remak : CAT_M1 Band 4 QPSK_5M Link_M-CH
 Tested by: Jisyong Wang

Freq	Level	Read Level	Limit Line	Over Limit	Factor	Remark
MHz	dBm	dBm	dBm	dB	dB	
1 pp 3465.00	-56.01	-47.10	-13.00	-43.01	-8.91	Peak



A D T

Data: 4

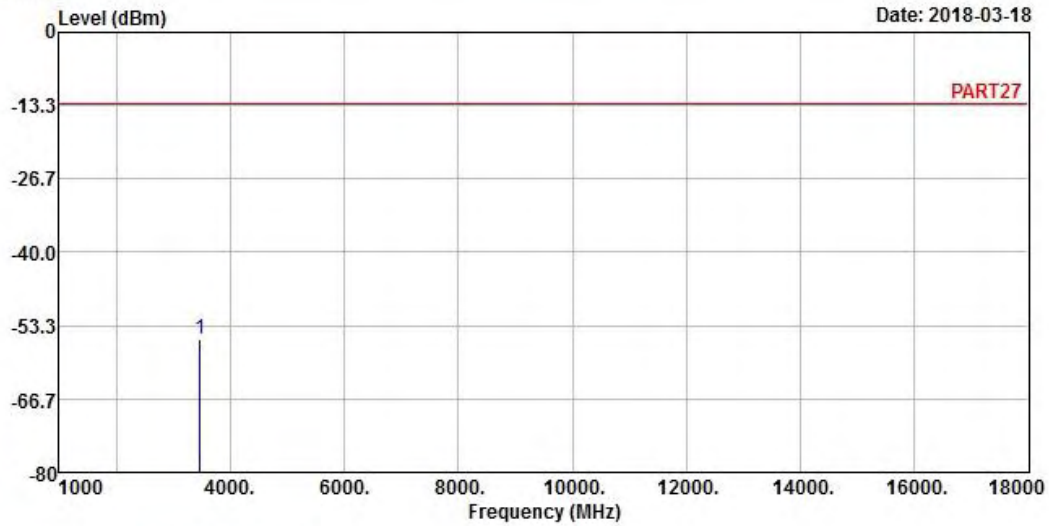

Site : 966 Chamber 5
 Condition: PART27 VERTICAL
 Remak : CAT_M1 Band 4 QPSK_5M Link_M-CH
 Tested by: Jisyong Wang

Freq	Level	Read Level	Limit Line	Over Limit	Factor	Remark
MHz	dBm	dBm	dBm	dB	dB	
1 pp 3465.00	-55.71	-46.80	-13.00	-42.71	-8.91	Peak

High Channel



Bureau Veritas Consumer Products Services Ltd., Taoyuan Branch

A D T

Data: 3

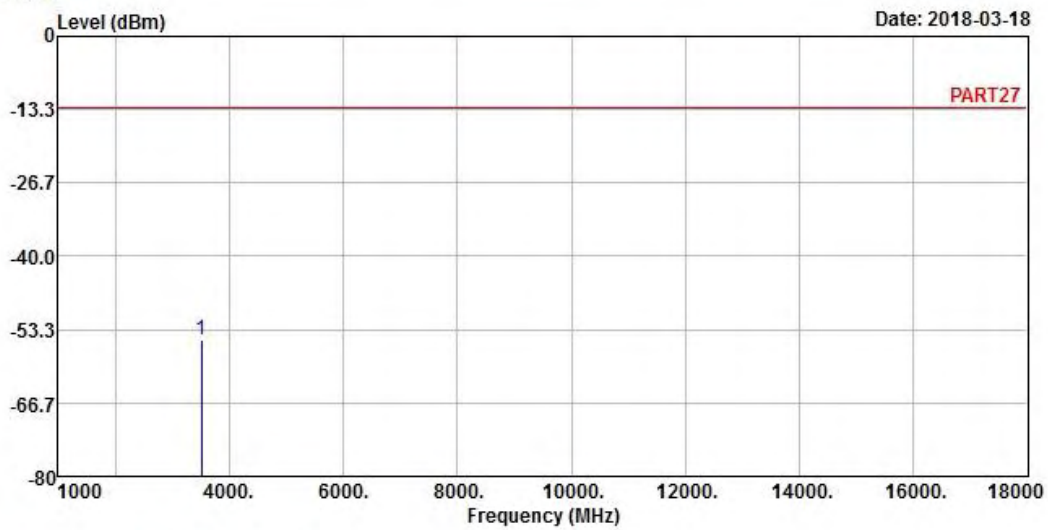

Site : 966 Chamber 5
 Condition: PART27 HORIZONTAL
 Remak : CAT_M1 Band 4 QPSK_5M Link_H-CH
 Tested by: Jisyong Wang

Freq	Level	Read Level	Limit	Over	Factor	Remark
MHz	dBm	dBm	dBm	dB	dB	
1 pp 3510.00	-55.35	-47.24	-13.00	-42.35	-8.11	Peak



A D T

Data: 4

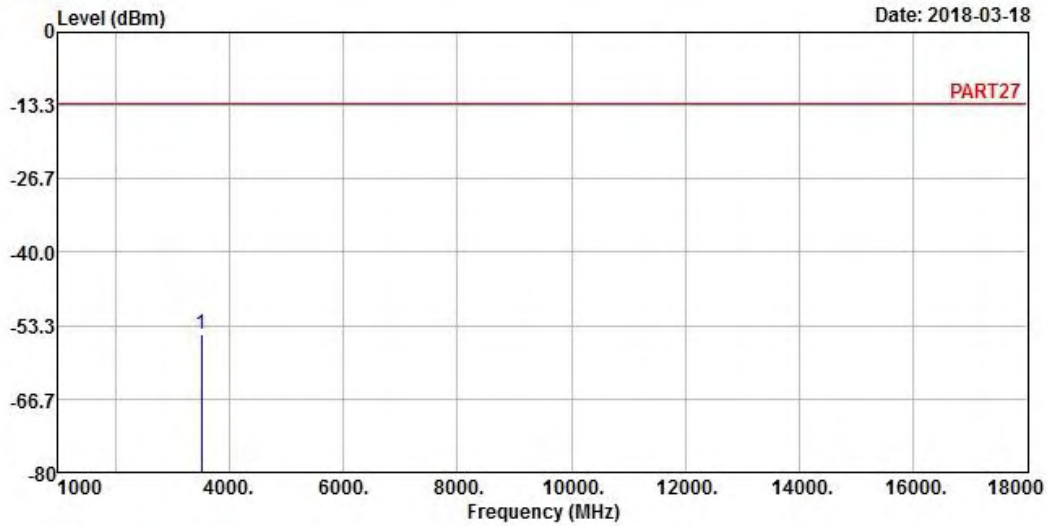

Site : 966 Chamber 5
 Condition: PART27 VERTICAL
 Remak : CAT_M1 Band 4 QPSK_5M Link_H-CH
 Tested by: Jisyong Wang

Freq	Level	Read Level	Limit Line	Over Limit	Factor	Remark
MHz	dBm	dBm	dBm	dB	dB	
1 pp 3505.00	-55.01	-46.90	-13.00	-42.01	-8.11	Peak

Channel Bandwidth: 20 MHz / QPSK
Low Channel



Bureau Veritas Consumer Products Services Ltd., Taoyuan Branch

A D T

Data: 3

Date: 2018-03-18

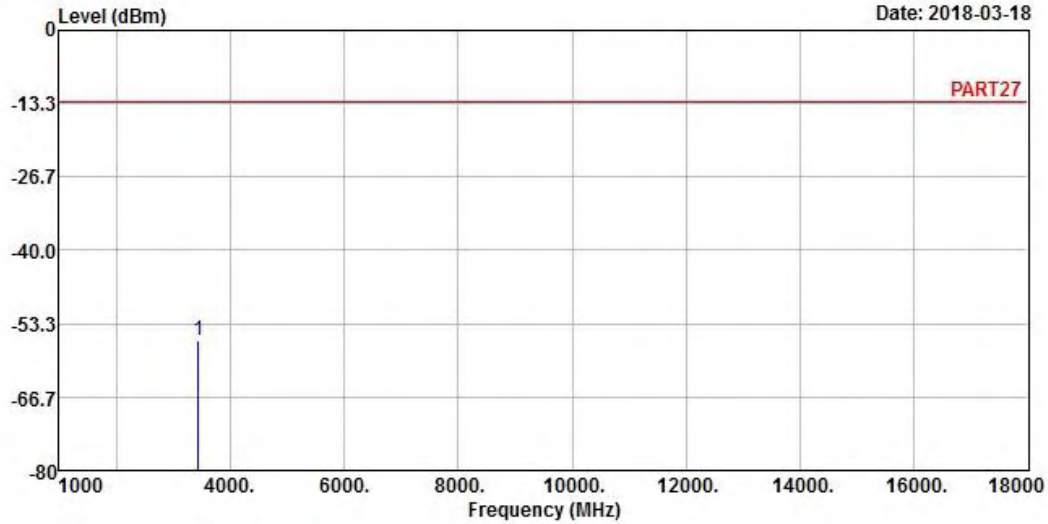

Site : 966 Chamber 5
 Condition: PART27 HORIZONTAL
 Remak : CAT_M1 Band 4 QPSK_20M Link_L-CH
 Tested by: Jisyong Wang

	Freq	Level	Read Level	Limit Line	Over Limit	Factor	Remark
	MHz	dBm	dBm	dBm	dB	dB	
1	pp 3440.00	-56.35	-47.35	-13.00	-43.35	-9.00	Peak



A D T

Data: 4

Date: 2018-03-18

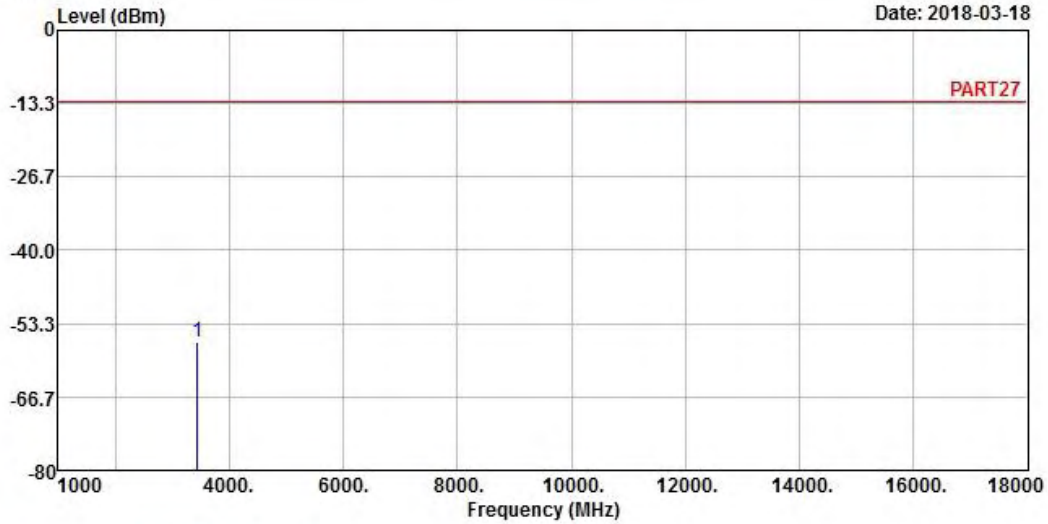

Site : 966 Chamber 5
 Condition: PART27 VERTICAL
 Remak : CAT_M1 Band 4 QPSK_20M Link_L-CH
 Tested by: Jisyong Wang

Freq	Level	Read Level	Limit Line	Over Limit	Factor	Remark
MHz	dBm	dBm	dBm	dB	dB	
1 pp 3440.00	-56.58	-47.58	-13.00	-43.58	-9.00	Peak

Middle Channel



Bureau Veritas Consumer Products Services Ltd., Taoyuan Branch

A D T

Data: 3

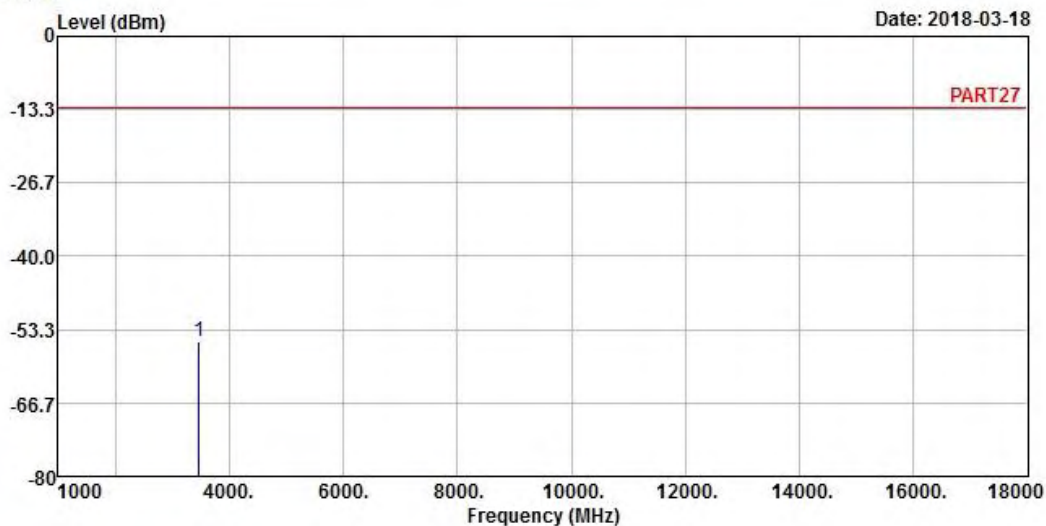

Site : 966 Chamber 5
 Condition: PART27 HORIZONTAL
 Remak : CAT_M1 Band 4 QPSK_20M Link_M-CH
 Tested by: Jisyong Wang

	Read	Limit	Over			
Freq	Level	Level	Line	Limit	Factor	Remark
MHz	dBm	dBm	dBm	dB	dB	
1 pp 3465.00	-55.52	-46.61	-13.00	-42.52	-8.91	Peak



A D T

Data: 4

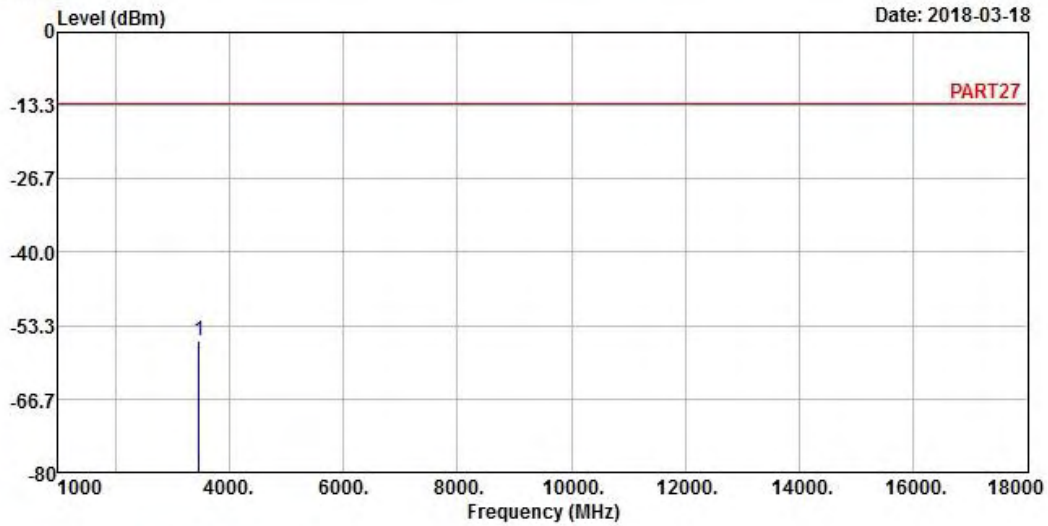

Site : 966 Chamber 5
 Condition: PART27 VERTICAL
 Remak : CAT_M1 Band 4 QPSK_20M Link_M-CH
 Tested by: Jisyong Wang

Freq	Level	Read Level	Limit Line	Over Limit	Factor	Remark
MHz	dBm	dBm	dBm	dB	dB	
1 pp 3465.00	-56.02	-47.11	-13.00	-43.02	-8.91	Peak

High Channel



Bureau Veritas Consumer Products Services Ltd., Taoyuan Branch

A D T

Data: 5

Date: 2018-03-18

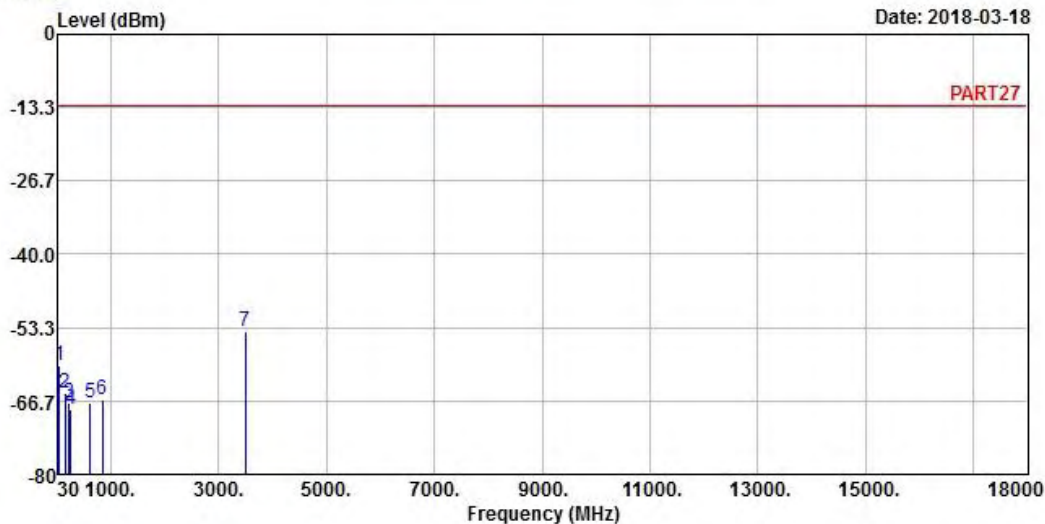

Site : 966 Chamber 5
 Condition: PART27 HORIZONTAL
 Remak : CAT_M1 Band 4 QPSK_20M Link_H-CH
 Tested by: Jisyong Wang

	Freq	Level	Read Level	Limit Line	Over Limit	Factor	Remark
	MHz	dBm	dBm	dBm	dB	dB	
1	53.28	-60.23	-54.42	-13.00	-47.23	-5.81	Peak
2	155.13	-65.38	-59.17	-13.00	-52.38	-6.21	Peak
3	234.67	-66.96	-60.34	-13.00	-53.96	-6.62	Peak
4	258.92	-68.31	-62.14	-13.00	-55.31	-6.17	Peak
5	617.82	-66.99	-66.19	-13.00	-53.99	-0.80	Peak
6	841.89	-66.40	-66.76	-13.00	-53.40	0.36	Peak
7 pp	3490.00	-54.01	-45.50	-13.00	-41.01	-8.51	Peak



A D T

Data: 6

Date: 2018-03-18

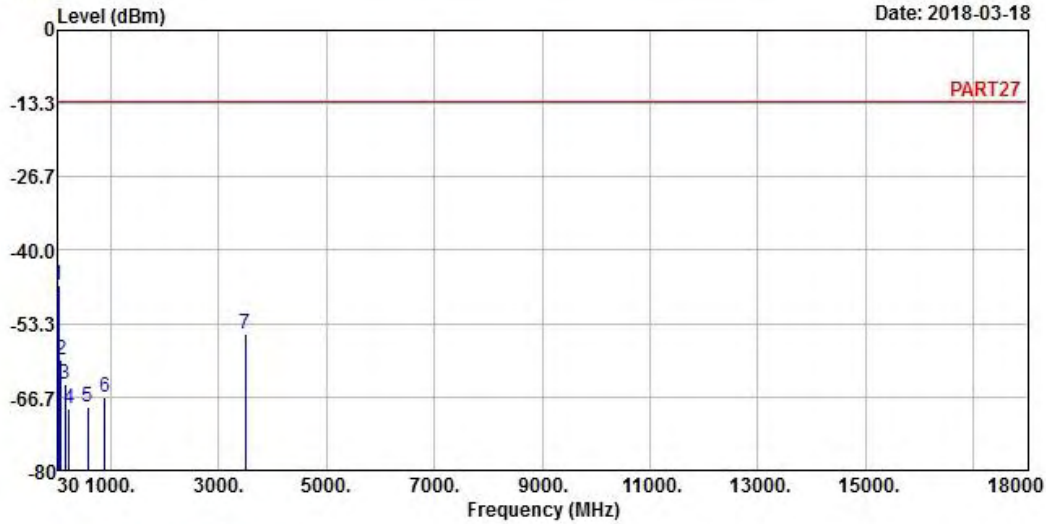

Site : 966 Chamber 5
 Condition: PART27 VERTICAL
 Remak : CAT_M1 Band 4 QPSK_20M Link_H-CH
 Tested by: Jisyong Wang

	Freq	Level	Read Level	Limit Line	Over Limit	Factor	Remark
	MHz	dBm	dBm	dBm	dB	dB	
1 pp	39.70	-46.22	-46.86	-13.00	-33.22	0.64	Peak
2	84.32	-59.98	-49.01	-13.00	-46.98	-10.97	Peak
3	153.19	-64.47	-57.71	-13.00	-51.47	-6.76	Peak
4	237.58	-68.77	-62.27	-13.00	-55.77	-6.50	Peak
5	570.29	-68.44	-66.44	-13.00	-55.44	-2.00	Peak
6	893.30	-66.58	-67.11	-13.00	-53.58	0.53	Peak
7	3490.00	-55.14	-46.63	-13.00	-42.14	-8.51	Peak

LTE Band 13
 Channel Bandwidth: 5 MHz / QPSK (1RB / 0RB Offset)
 Low Channel



Bureau Veritas Consumer Products Services Ltd., Taoyuan Branch

A D T

Data: 3

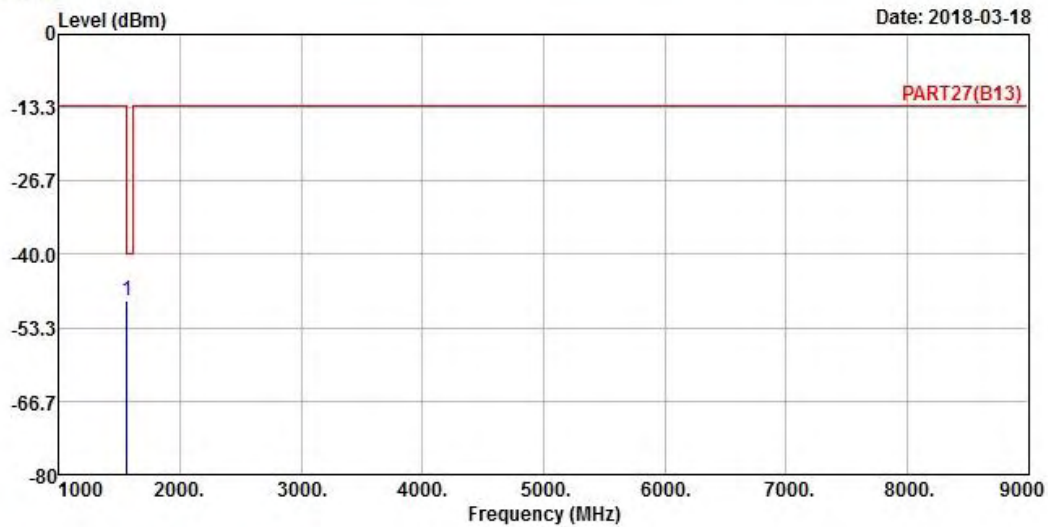

Site : 966 Chamber 5
 Condition: PART27(B13) HORIZONTAL
 Remak : CAT_M1 Band 13 QPSK_5M Link_L-CH
 Tested by: Jistong Wang

Read	Limit	Over				
Freq	Level	Level	Line	Limit	Factor	Remark
MHz	dBm	dBm	dBm	dB	dB	
1 pp 1559.00	-48.40	-33.38	-40.00	-8.40	-15.02	Peak



A D T

Data: 4

Date: 2018-03-18

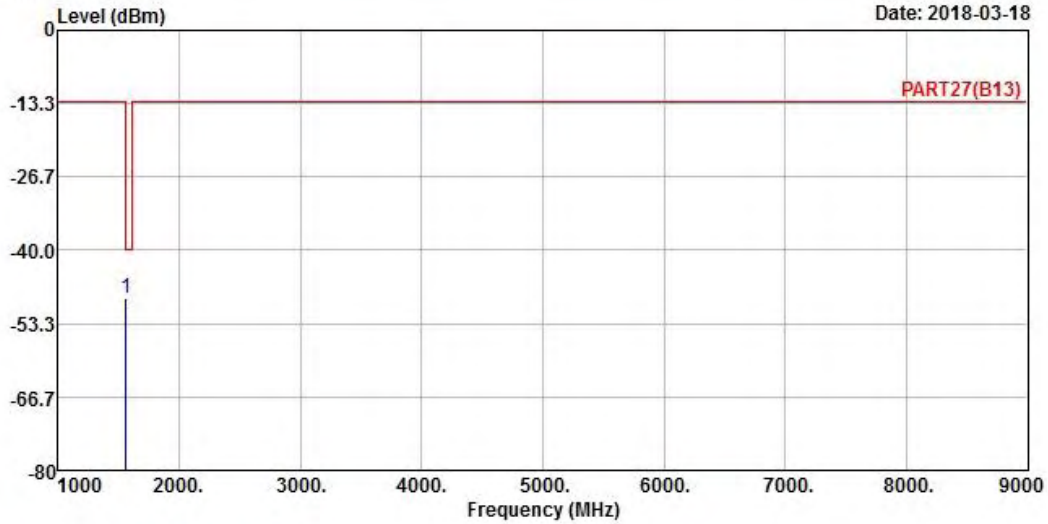

Site : 966 Chamber 5
 Condition: PART27(B13) VERTICAL
 Remak : CAT_M1 Band 13 QPSK_5M Link_L-CH
 Tested by: Jistong Wang

Freq	Level	Read Level	Limit Line	Over Limit	Factor	Remark
MHz	dBm	dBm	dBm	dB	dB	
1 pp 1559.00	-48.81	-33.79	-40.00	-8.81	-15.02	Peak

Middle Channel



Bureau Veritas Consumer Products Services Ltd., Taoyuan Branch

A D T

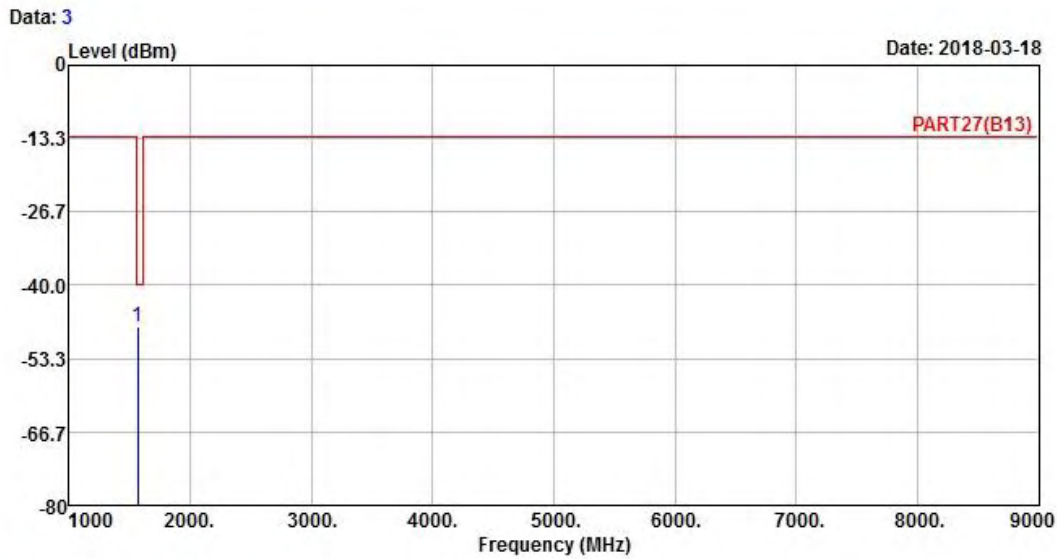

Site : 966 Chamber 5
 Condition: PART27(B13) HORIZONTAL
 Remak : CAT_M1 Band 13 QPSK_5M Link_M-CH
 Tested by: Jistong Wang

Freq	Level	Read Level	Limit	Over	Factor	Remark
MHz	dBm	dBm	dBm	dB	dB	
1 pp 1564.00	-47.40	-32.38	-40.00	-7.40	-15.02	Peak



A D T

Data: 4

Date: 2018-03-18

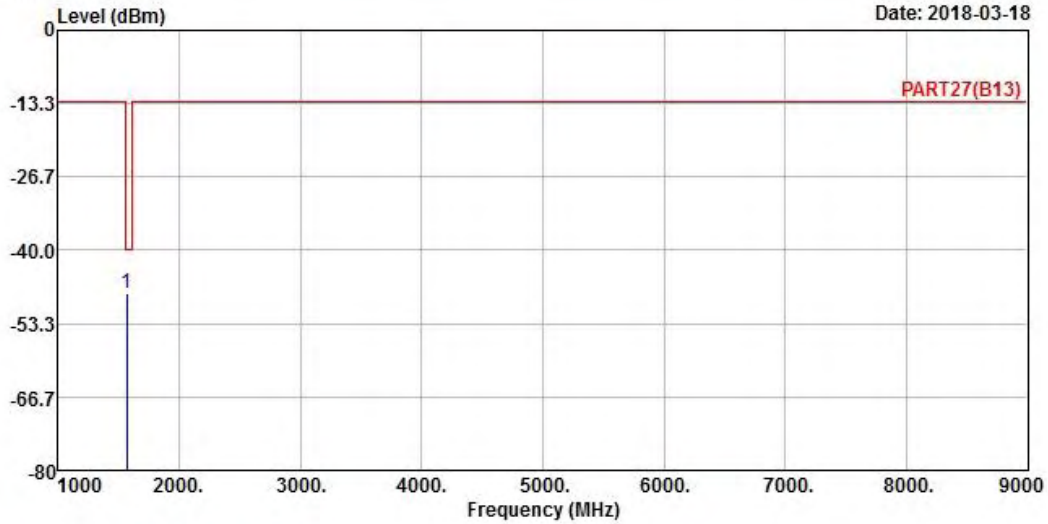

Site : 966 Chamber 5
 Condition: PART27(B13) VERTICAL
 Remak : CAT_M1 Band 13 QPSK_5M Link_M-CH
 Tested by: Jistong Wang

Freq	Level	Read Level	Limit Line	Over Limit	Factor	Remark
MHz	dBm	dBm	dBm	dB	dB	
1 pp 1564.00	-47.81	-32.79	-40.00	-7.81	-15.02	Peak

High Channel



Bureau Veritas Consumer Products Services Ltd., Taoyuan Branch

A D T

Data: 3

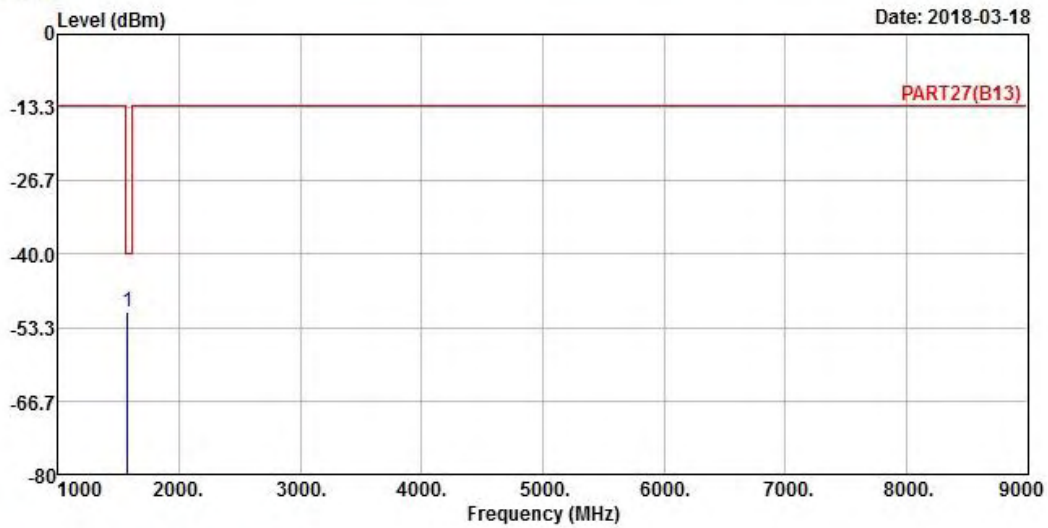

Site : 966 Chamber 5
 Condition: PART27(B13) HORIZONTAL
 Remak : CAT_M1 Band 13 QPSK_5M Link_H-CH
 Tested by: Jistong Wang

Freq	Level	Read Level	Limit	Over	Factor	Remark
MHz	dBm	dBm	dBm	dB	dB	

1 pp 1569.00 -50.40 -35.44 -40.00 -10.40 -14.96 Peak



A D T

Data: 4

Date: 2018-03-18

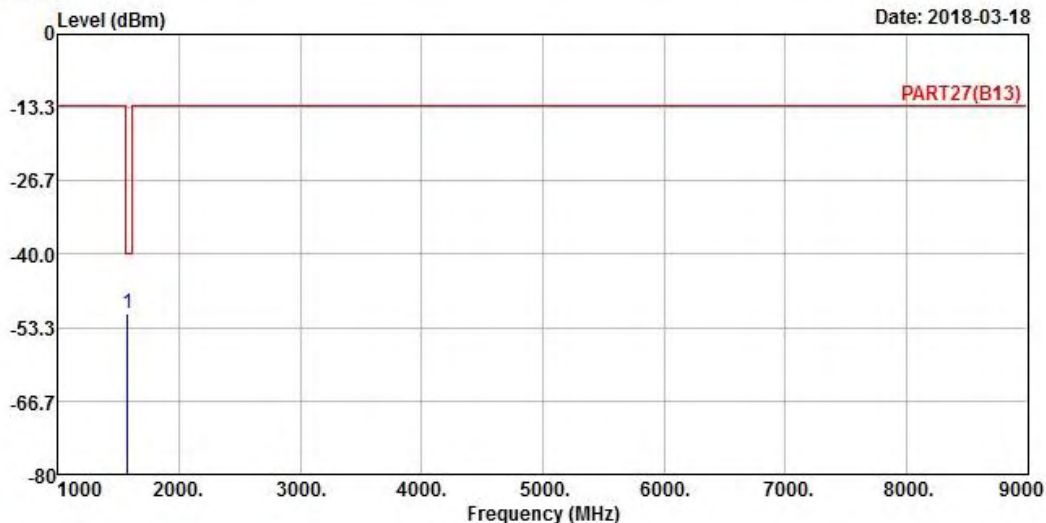

Site : 966 Chamber 5
 Condition: PART27(B13) VERTICAL
 Remak : CAT_M1 Band 13 QPSK_5M Link_H-CH
 Tested by: Jistong Wang

Freq	Level	Read Level	Limit Line	Over Limit	Factor	Remark
MHz	dBm	dBm	dBm	dB	dB	
1 pp 1569.00	-50.81	-35.85	-40.00	-10.81	-14.96	Peak

Channel Bandwidth: 10 MHz / QPSK (1RB / 0RB Offset)
Middle Channel



Bureau Veritas Consumer Products Services Ltd., Taoyuan Branch

A D T

Data: 5

Date: 2018-03-18

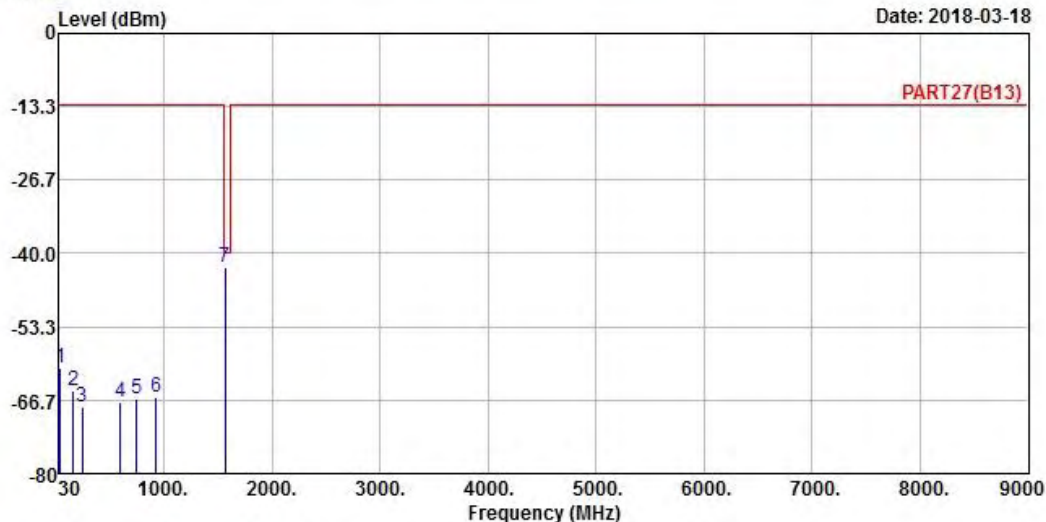

Site : 966 Chamber 5
Condition: PART27(B13) HORIZONTAL
Remak : CAT_M1 Band 13 QPSK_10M Link_M-CH
Tested by: Jistong Wang

	Freq	Level	Read Level	Limit Line	Over Limit	Factor	Remark
	MHz	dBm	dBm	dBm	dB	dB	
1	42.61	-60.75	-59.81	-13.00	-47.75	-0.94	Peak
2	159.01	-64.89	-59.77	-13.00	-51.89	-5.12	Peak
3	240.49	-67.96	-61.58	-13.00	-54.96	-6.38	Peak
4	599.39	-66.97	-66.18	-13.00	-53.97	-0.79	Peak
5	743.92	-66.47	-67.23	-13.00	-53.47	0.76	Peak
6	926.28	-66.24	-67.46	-13.00	-53.24	1.22	Peak
7 pp	1564.00	-42.52	-27.50	-40.00	-2.52	-15.02	Peak



A D T

Data: 6

Date: 2018-03-18

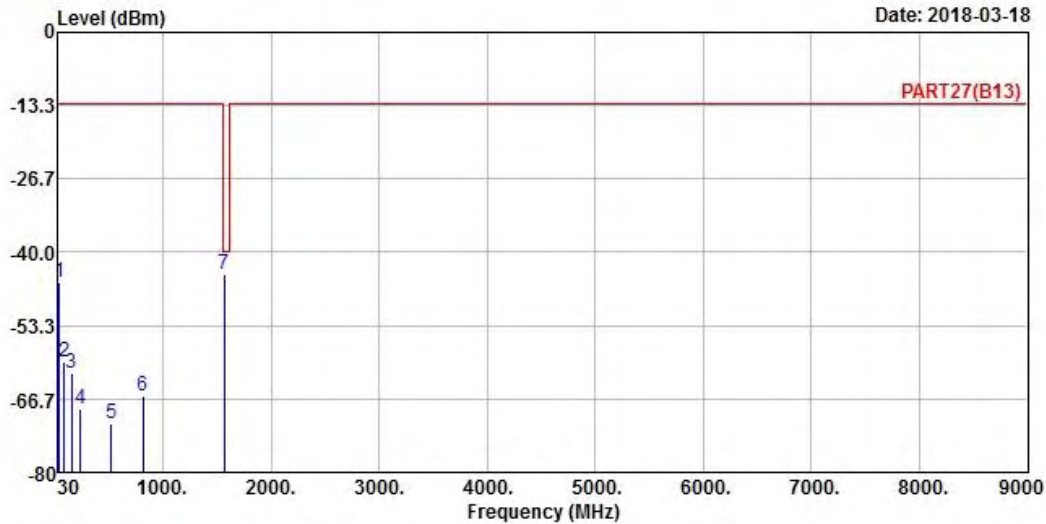

Site : 966 Chamber 5
 Condition: PART27(B13) VERTICAL
 Remak : CAT_M1 Band 13 QPSK_10M Link_M-CH
 Tested by: Jistong Wang

	Freq	Level	Read Level	Limit Line	Over Limit	Factor	Remark
	MHz	dBm	dBm	dBm	dB	dB	
1	39.70	-45.49	-46.13	-13.00	-32.49	0.64	Peak
2	84.32	-59.91	-48.94	-13.00	-46.91	-10.97	Peak
3	153.19	-61.98	-55.22	-13.00	-48.98	-6.76	Peak
4	236.61	-68.40	-61.86	-13.00	-55.40	-6.54	Peak
5	518.88	-71.06	-67.11	-13.00	-58.06	-3.95	Peak
6	813.76	-66.11	-66.72	-13.00	-53.11	0.61	Peak
7 pp	1564.00	-44.05	-29.03	-40.00	-4.05	-15.02	Peak

Channel Bandwidth: 5 MHz / QPSK (6RB / 0RB Offset)
 Low Channel



Bureau Veritas Consumer Products Services Ltd., Taoyuan Branch

A D T

Data: 3

Date: 2018-03-18

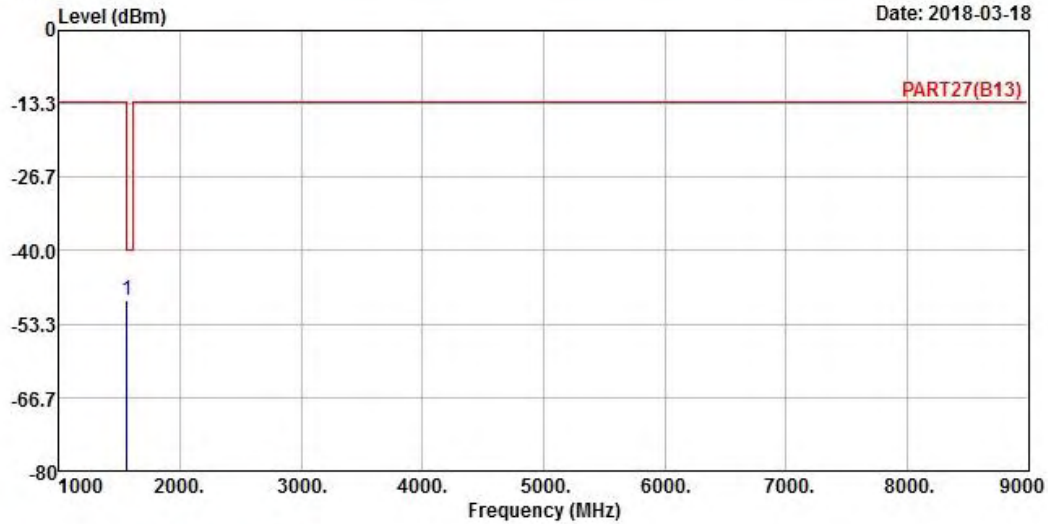

Site : 966 Chamber 5
 Condition: PART27(B13) HORIZONTAL
 Remak : CAT_M1 Band 13 QPSK_5M Link_L-CH
 Tested by: Jistong Wang

Freq	Level	Read Level	Limit Line	Over Limit	Factor	Remark
MHz	dBm	dBm	dBm	dB	dB	
1 pp 1559.00	-48.87	-33.85	-40.00	-8.87	-15.02	Peak



A D T

Data: 4

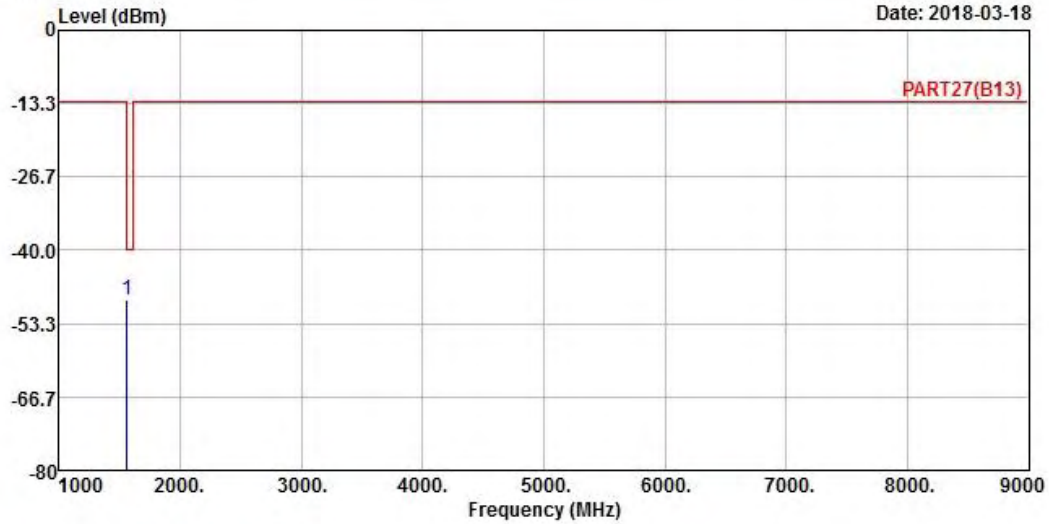

Site : 966 Chamber 5
 Condition: PART27(B13) VERTICAL
 Remak : CAT_M1 Band 13 QPSK_5M Link_L-CH
 Tested by: Jistong Wang

Freq	Level	Read Level	Limit Line	Over Limit	Factor	Remark
MHz	dBm	dBm	dBm	dB	dB	
1 pp 1559.00	-49.03	-34.01	-40.00	-9.03	-15.02	Peak

Middle Channel



Bureau Veritas Consumer Products Services Ltd., Taoyuan Branch

A D T

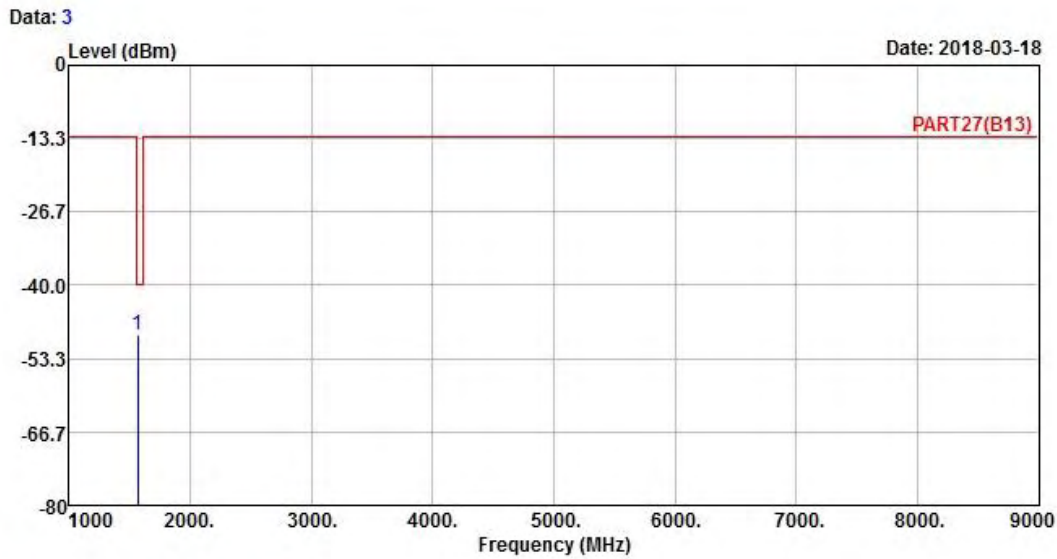

Site : 966 Chamber 5
 Condition: PART27(B13) HORIZONTAL
 Remak : CAT_M1 Band 13 QPSK_5M Link_M-CH
 Tested by: Jistong Wang

	Read	Limit	Over			
Freq	Level	Level	Line	Limit	Factor	Remark
MHz	dBm	dBm	dBm	dB	dB	
1 pp 1564.00	-49.00	-33.98	-40.00	-9.00	-15.02	Peak



A D T

Data: 4

Date: 2018-03-18

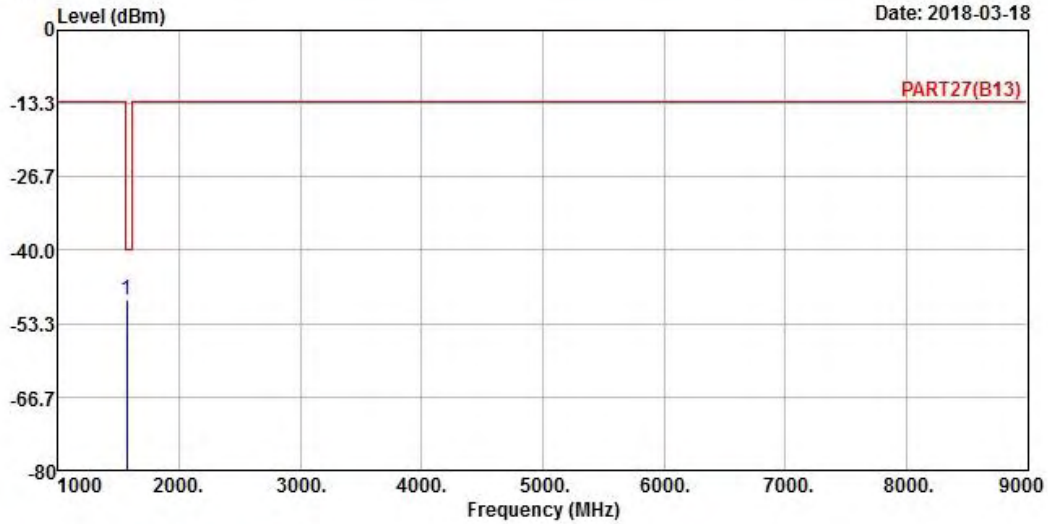

Site : 966 Chamber 5
 Condition: PART27(B13) VERTICAL
 Remak : CAT_M1 Band 13 QPSK_5M Link_M-CH
 Tested by: Jistong Wang

Freq	Level	Read Level	Limit Line	Over Limit	Factor	Remark
MHz	dBm	dBm	dBm	dB	dB	
1 pp 1564.00	-48.93	-33.91	-40.00	-8.93	-15.02	Peak

High Channel



Bureau Veritas Consumer Products Services Ltd., Taoyuan Branch

A D T

Data: 3

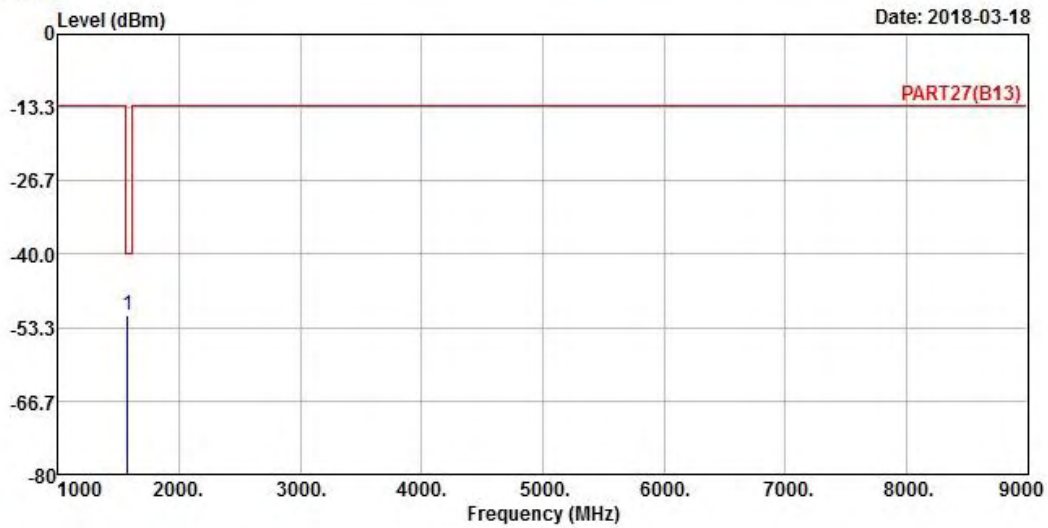

Site : 966 Chamber 5
 Condition: PART27(B13) HORIZONTAL
 Remak : CAT_M1 Band 13 QPSK_5M Link_H-CH
 Tested by: Jistong Wang

Freq	Level	Read Level	Limit	Over	Factor	Remark
MHz	dBm	dBm	dBm	dB	dB	

1 pp 1569.00 -50.94 -35.98 -40.00 -10.94 -14.96 Peak



A D T

Data: 4

Date: 2018-03-18

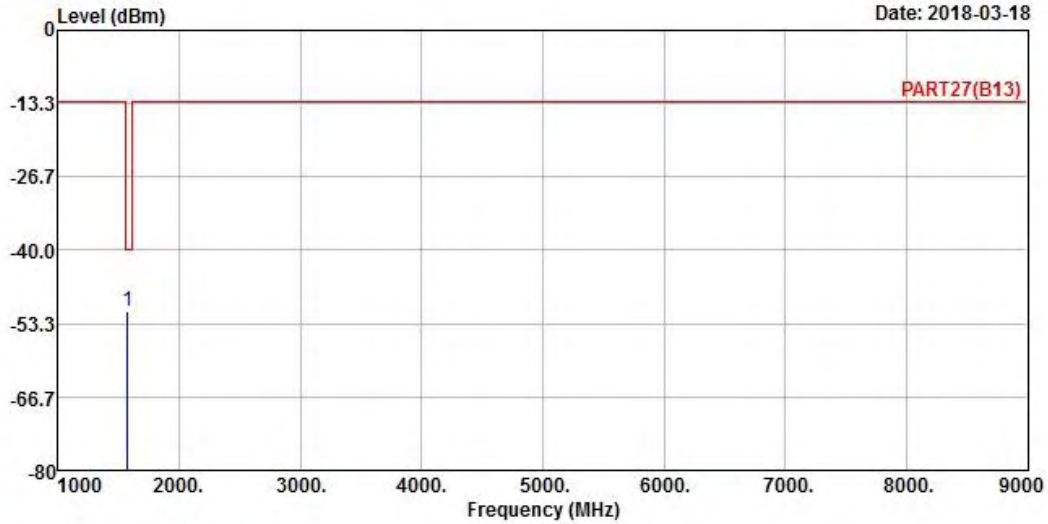

Site : 966 Chamber 5
 Condition: PART27(B13) VERTICAL
 Remak : CAT_M1 Band 13 QPSK_5M Link_H-CH
 Tested by: Jistong Wang

Freq	Level	Read Level	Limit Line	Over Limit	Factor	Remark
MHz	dBm	dBm	dBm	dB	dB	
1 pp 1569.00	-51.21	-36.25	-40.00	-11.21	-14.96	Peak

Channel Bandwidth: 10 MHz / QPSK (6RB / 0RB Offset)
Middle Channel



Bureau Veritas Consumer Products Services Ltd., Taoyuan Branch

A D T

Data: 3

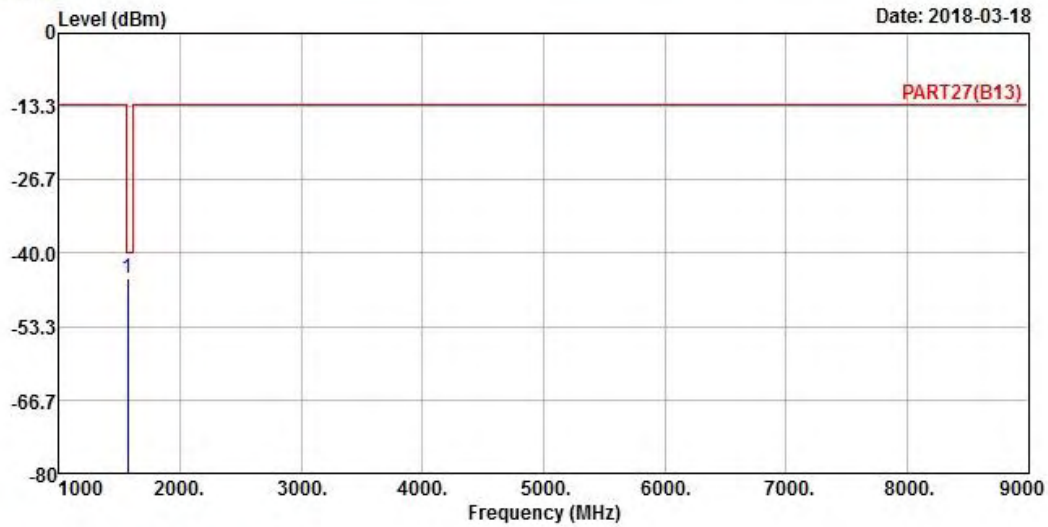

Site : 966 Chamber 5
Condition: PART27(B13) HORIZONTAL
Remak : CAT_M1 Band 13 QPSK_10M Link_M-CH
Tested by: Jistong Wang

Freq	Level	Read Level	Limit Line	Over Limit	Factor	Remark
MHz	dBm	dBm	dBm	dB	dB	
1 pp 1564.00	-44.52	-29.50	-40.00	-4.52	-15.02	Peak



A D T

Data: 4

Date: 2018-03-18

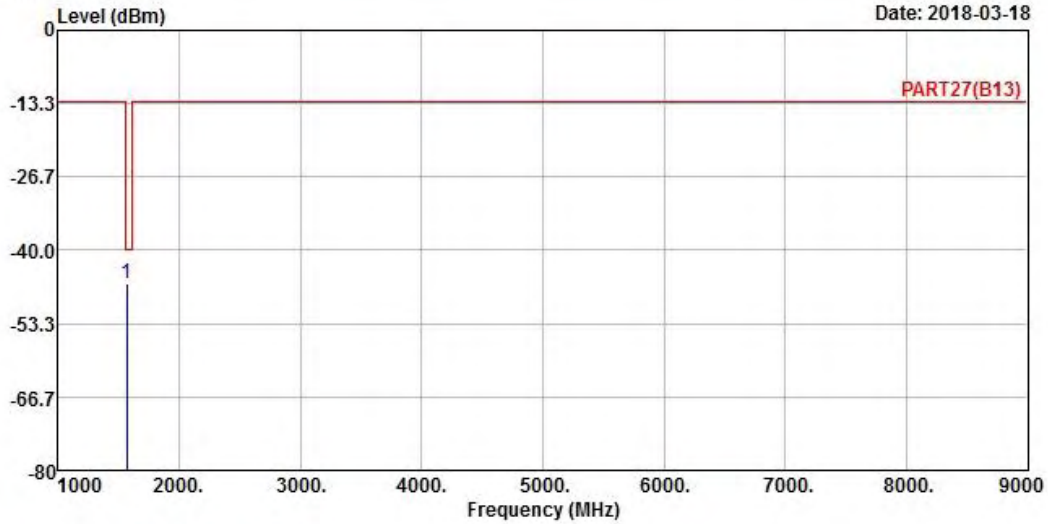

Site : 966 Chamber 5
 Condition: PART27(B13) VERTICAL
 Remak : CAT_M1 Band 13 QPSK_10M Link_M-CH
 Tested by: Jistong Wang

Freq	Level	Read Level	Limit Line	Over Limit	Factor	Remark
MHz	dBm	dBm	dBm	dB	dB	
1 pp 1564.00	-46.05	-31.03	-40.00	-6.05	-15.02	Peak

5 Pictures of Test Arrangements

Please refer to the attached file (Test Setup Photo).

Appendix – Information on the Testing Laboratories

We, Bureau Veritas Consumer Products Services (H.K.) Ltd., Taoyuan Branch, were founded in 1988 to provide our best service in EMC, Radio, Telecom and Safety consultation. Our laboratories are FCC recognized accredited test firms and accredited according to ISO/IEC 17025.

If you have any comments, please feel free to contact us at the following:

Linko EMC/RF Lab

Tel: 886-2-26052180

Fax: 886-2-26051924

Hsin Chu EMC/RF/Telecom Lab

Tel: 886-3-6668565

Fax: 886-3-6668323

Hwa Ya EMC/RF/Safety

Tel: 886-3-3183232

Fax: 886-3-3270892

Email: service.adt@tw.bureauveritas.com

Web Site: www.bureauveritas-adt.com

The address and road map of all our labs can be found in our web site also.

--- END ---