



731 Enterprise Drive
Lexington, KY 40510

Telephone: 859-226-1000
Facsimile: 859-226-1040
www.intertek-etlsemko.com

TEST REPORT

Report Number: 102594044LEX-001
Project Number: G102594044

Report Issue Date: 5/31/2016

Product Name: US130Q LTE E-UTRA

FCC Standards: Title 47 CFR Part 24 and 27

Industry Canada Standards: RSS-133 Issue 6, RSS-130 Issue 1, and
RSS-139 Issue 3

Tested by:
Intertek Testing Services NA, Inc.
731 Enterprise Drive
Lexington, KY 40510

Client:
Sequans Communications
19 Le Parvies de La Defense, LA Defence
Paris, France

Report prepared by

Brian Daffin,
Engineer

Report reviewed by

Bryan Taylor,
Team Leader



This report is for the exclusive use of Intertek's Client and is provided pursuant to the agreement between Intertek and its Client. Intertek's responsibility and liability are limited to the terms and conditions of the agreement. Intertek assumes no liability to any party, other than to the Client in accordance with the agreement, for any loss, expense or damage occasioned by the use of this report. Only the Client is authorized to permit copying or distribution of this report and then only in its entirety. Any use of the Intertek name or one of its marks for the sale or advertisement of the tested material, product or service must first be approved in writing by Intertek. The observations and test results in this report are relevant only to the sample tested. This report by itself does not imply that the material, product, or service is or has ever been under an Intertek certification program.

TABLE OF CONTENTS

1 Introduction and Conclusion..... 3

2 Test Summary 3

3 Description of Equipment Under Test 4

4 Conducted Output Power..... 6

5 Occupied Bandwidth 8

6 Conducted Spurious Emissions at Antenna Terminals..... 27

7 Radiated Output Power 54

8 Radiated Spurious Emissions (Transmitter)..... 56

9 Frequency Stability..... 61

10 Measurement Uncertainty 63

11 Revision History..... 64

1 Introduction and Conclusion

The tests indicated in Section 2 were performed on the product constructed as described in Section 3. The remaining test sections are the verbatim text from the actual data sheets used during the investigation. These test sections include the test name, the specified test method, a list of the actual test equipment used, documentation photos, results and raw data. No additions, deviations, or exclusions have been made from the standard(s) unless specifically noted.

Based on the results of our investigation, we have concluded the product tested complied with the requirements of the standard(s) indicated. The results obtained in this test report pertain only to the item(s) tested.

The INTERTEK-Lexington laboratory is located at 731 Enterprise Drive, Lexington Kentucky, 40510. The radiated emission test site is a 10-meter semi-anechoic chamber. The chamber meets the characteristics of CISPR 16-1 and ANSI C63.4. For measurements, a remotely controlled flush-mount metal-top turntable is used to rotate the EUT a full 360 degrees. A remote controlled non-conductive antenna mast is used to scan the antenna height from one to four meters. The test site is listed with the FCC under Registration Number 485103.

2 Test Summary

Page	Test full name	FCC Reference	Industry Canada	Result
6	Conducted Output Power	§ 24.232(c) § 27.50(c)(d)	RSS-133 (6.4) RSS-130 (4.4) RSS-139 (6.5)	Pass
8	Occupied Bandwidth	§2.1049	RSS-GEN (4.6.1)	Pass
27	Conducted Spurious Emissions	§ 24.238(a)(b) §27.53(g)(h)	RSS-133 (6.5) RSS-130 (4.6) RSS-139 (6.6)	Pass
29	Radiated Output Power	§ 24.232(c) § 27.50(c)(d)	RSS-133 (6.4) RSS-130 (4.4) RSS-139 (6.5)	Pass
56	Radiated Spurious Emissions (Transmitter)	§24.238(a)(b) §27.53(g)(h)	RSS-133 (6.5) RSS-130 (4.6) RSS-139 (6.6)	Pass
58	Frequency Stability	§24.235 §27.54	RSS-133 (6.3) RSS-130 (4.3) RSS-139 (6.4)	Pass

3 Description of Equipment Under Test

Equipment Under Test	
Manufacturer	Sequans Communications
Model Number	US130Q LTE E-UTRA
Serial Number	USQ1602230021011
Receive Date	5/2/2016
Test Start Date	5/2/2016
Test End Date	5/20/2016
Device Received Condition	Good
Test Sample Type	Production
Frequency Band	1850MHz – 1910MHz (Band 2) 1710MHz – 1755MHz (Band 4) 698MHz – 716MHz (Band 12)
Modulation Type	LTE, QPSK and 16-QAM
Transmission Control	Base Station Simulator
Maximum Output Power (Conducted)	23.28 dBm (Band 2) 23.38 dBm (Band 4) 23.29 dBm (Band 12)
Antenna Type	External
Operating Voltage	3.3VDC

Description of Equipment Under Test

The US130Q LTE E-UTRA is a standalone wireless LTE module which operates in bands 2, 4, and 12.

Operating modes of the EUT:

No.	Descriptions of EUT Exercising
1	Transmitting an LTE signal
2	Receive / idle mode

3.1 System setup including cable interconnection details, support equipment and simplified block diagram

3.2 EUT Block Diagram:

Block Diagram for Radiated Tests

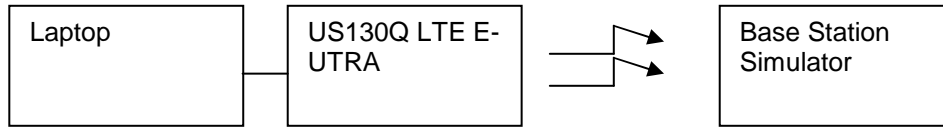

Block Diagram for Conducted Tests at the Antenna Port

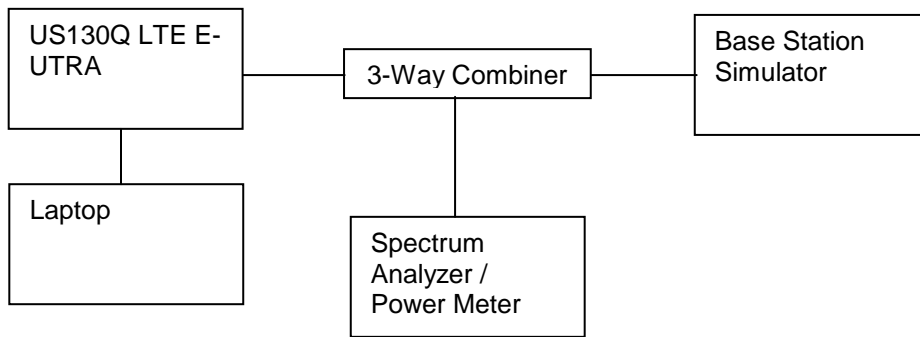

3.3 Cables:

Cables					
Description	Length	Shielding	Ferrites	Connection	
				From	To
USB Cable	3ft	Yes	None	Laptop	USB Input to Debug Board

4 Conducted Output Power

4.1 Test Limits

§ 2.1046

For transmitters other than single sideband, independent sideband and controlled carrier radiotelephone, power output shall be measured at the RF output terminals when the transmitter is adjusted in accordance with the tune-up procedure to give the values of current and voltage on the circuit elements specified in §2.1033(c)(8).

§ 24.232

(c) Mobile and portable stations are limited to 2 watts EIRP and the equipment must employ a means for limiting power to the minimum necessary for successful communications

(d) Power measurements for transmissions by stations authorized under this section may be made either in accordance with a Commission-approved average power technique or in compliance with paragraph (e) of this section. In both instances, equipment employed must be authorized in accordance with the provisions of §24.51. In measuring transmissions in this band using an average power technique, the peak-to-average ratio (PAR) of the transmission may not exceed 13 dB.

§ 27.50

(c)(10) Portable stations (hand-held devices) in the 600 MHz uplink band and the 698-746 MHz band, and fixed and mobile stations in the 600 MHz uplink band are limited to 3 watts ERP.

(d)(4) Fixed, mobile, and portable (hand-held) stations operating in the 1710-1755 MHz band and mobile and portable stations operating in the 1695-1710 MHz and 1755-1780 MHz bands are limited to 1 watt EIRP. Fixed stations operating in the 1710-1755 MHz band are limited to a maximum antenna height of 10 meters above ground. Mobile and portable stations operating in these bands must employ a means for limiting power to the minimum necessary for successful communications.

4.2 Test Procedure

The transmitter output was connected to a coaxial cable, the other end of which was connected to a Base Station Simulator. The Base Station Simulator was set to force the EUT to its maximum power setting. The EUT was placed into a call and the average power was measured. The power output at the transmitter antenna port was determined by adding the value of the cable insertion loss to the power reading. Tests were performed at three frequencies (low, middle, and high channels) and on the highest power levels, which can be setup on the transmitters.

The peak-to-average ratio (PAR) was measured using a spectrum analyzer with a RBW wider than the EBW of the measured signal. The delta between the peak and average trace was recorded.

4.3 Test Equipment Used:

Description	Serial Number	Manufacturer	Model	Cal. Date	Cal. Due
Base Station Simulator	3917	Rohde & Schwarz	CMW500	9/19/2015	9/19/2016
Spectrum Analyzer	3099	Rohde & Schwarz	FSP7	9/18/2015	9/18/2016
Power Divider	E18106	Weinschell Engineering	1506A	Time of Use	Time of Use

4.4 Results:

The table below shows the conducted output power delivered to the radiating antenna. Plots are also provided showing that the peak to average ratio (crest in the attached plots) is below the 13dB limit.

Conducted Output Power Band 2

BW	Channel	Frequency	Modulation	No RB	RB Offset	Avg. Power (dBm)	Peak Power (dBm)
5MHz	18625	1852.5 MHz	QPSK	1	Low	22.84	27.14
				1	High	22.82	27.5
				25	Low	21.52	27.78
			16QAM	1	Low	21.77	27.38
				1	High	21.88	27.62
				25	Low	20.42	27.23
	18900	1880MHz	QPSK	1	Low	23.17	28.33
				1	High	23.21	28.01
				25	Low	23.28	28.09
			16QAM	1	Low	22.61	28.32
				1	High	22.61	28.37
				25	Low	20.82	28.27
	19175	1907.5MHz	QPSK	1	Low	23.23	28.11
				1	High	22.28	27.48
				25	Low	22.02	27.62
16QAM			1	Low	22.68	26.79	
			1	High	21.95	26.14	
			25	Low	21.24	28.54	

Conducted Output Power Band 2

BW	Channel	Frequency	Modulation	No RB	RB Offset	Avg. Power (dBm)	Peak Power (dBm)
10MHz	18650	1855MHz	QPSK	1	Low	22.49	26.86
				1	High	22.61	27.15
				50	Low	21.24	28.31
			16QAM	1	Low	20.73	25.82
				1	High	20.93	25.98
				27	Low	19.89	27.55
	18900	1880MHz	QPSK	1	Low	21.39	26.83
				1	High	21.36	26.82
				50	Low	20.84	27.98
			16QAM	1	Low	20.83	26.01
				1	High	20.89	26.06
				27	Low	20.99	28.12
	19150	1905MHz	QPSK	1	Low	22.22	27.13
				1	High	21.65	26.28
				50	Low	20.98	27.37
			16QAM	1	Low	21.24	26.04
				1	High	20.76	25.54
				27	Low	20.22	26.98

Conducted Output Power Band 2

BW	Channel	Frequency	Modulation	No RB	RB Offset	Avg. Power (dBm)	Peak Power (dBm)
15MHz	18675	1857.5MHz	QPSK	1	Low	21.61	27.03
				1	High	21.56	26.47
				75	Low	20.79	26.89
			16QAM	1	Low	20.55	25.26
				1	High	20.51	25.14
				27	Low	20.47	27.02
	18900	1880MHz	QPSK	1	Low	21.69	26.92
				1	High	21.44	26.81
				75	Low	20.81	26.94
			16QAM	1	Low	20.74	24.75
				1	High	20.75	24.79
				27	Low	20.74	26.77
	19125	1902.5MHz	QPSK	1	Low	22.38	27.61
				1	High	21.45	26.24
				75	Low	21.46	27.52
16QAM			1	Low	21.61	26.68	
			1	High	21.28	26.09	
			27	Low	20.48	26.92	

Conducted Output Power Band 2

BW	Channel	Frequency	Modulation	No RB	RB Offset	Avg. Power (dBm)	Peak Power (dBm)
20MHz	18700	1860MHz	QPSK	1	Low	22.26	26.31
				1	High	22.37	26.57
				100	Low	20.61	27.46
			16QAM	1	Low	21.89	26.94
				1	High	22.14	27.36
				27	Low	20.91	27.42
	18900	1880MHz	QPSK	1	Low	23.18	27.62
				1	High	22.69	26.83
				100	Low	20.91	27.89
			16QAM	1	Low	21.98	27.78
				1	High	21.84	27.64
				27	Low	20.12	27.25
	19100	1900MHz	QPSK	1	Low	22.67	26.92
				1	High	22.21	26.35
				100	Low	21.33	27.68
16QAM			1	Low	22.35	27.49	
			1	High	22.22	26.67	
			27	Low	21.15	27.19	

Conducted Output Power Band 4

BW	Channel	Frequency	Modulation	RB Size	RB Offset	Max. Avg. Power (dBm)	Peak Power (dBm)		
5MHz	19975	1712.5MHz	QPSK	1	Low	21.93	27.23		
				1	High	21.99	27.41		
				25	Low	21.09	26.92		
			16QAM	1	Low	19.96	25.03		
				1	High	20.44	25.83		
	20175	1732.5MHz	QPSK	25	Low	20.13	27.71		
				1	Low	21.61	26.15		
				1	High	21.68	26.23		
			16QAM	25	Low	20.73	26.76		
				1	Low	21.26	26.36		
				1	High	20.31	26.37		
			20375	1752.5MHz	QPSK	25	Low	19.81	26.88
						1	Low	22.13	26.92
						1	High	22.13	26.84
	16QAM	25			Low	21.28	27.66		
1		Low			21.25	26.85			
1		High			21.21	26.82			
			25	Low	20.38	27.39			

Conducted Output Power Band 4

BW	Channel	Frequency	Modulation	RB Size	RB Offset	Max. Avg. Power (dBm)	Peak Power (dBm)		
10MHz	20000	1715.0MHz	QPSK	1	Low	21.77	26.77		
				1	High	21.74	26.82		
				50	Low	20.91	26.93		
			16QAM	1	Low	20.95	25.74		
				1	High	20.82	25.91		
	20175	1732.5MHz	QPSK	27	Low	20.55	27.14		
				1	Low	22.08	27.31		
				1	High	21.42	26.75		
			16QAM	50	Low	20.49	26.48		
				1	Low	20.43	25.65		
				1	High	20.45	25.59		
			20350	1750.0MHz	QPSK	27	Low	20.45	27.06
						1	Low	21.94	27.19
						1	High	22.13	27.22
	16QAM	50			Low	20.98	27.35		
1		Low			21.24	25.19			
1		High			21.48	25.44			
			27	Low	20.41	27.17			

Conducted Output Power Band 4

BW	Channel	Frequency	Modulation	RB Size	RB Offset	Max. Avg. Power (dBm)	Peak Power (dBm)
15MHz	20025	1717.5MHz	QPSK	1	Low	21.83	25.84
				1	High	21.72	25.84
				75	Low	21.11	27.43
			16QAM	1	Low	21.13	25.54
				1	High	21.15	25.65
	20175	1732.5MHz	QPSK	1	Low	21.98	27.57
				1	High	21.76	27.34
				75	Low	20.99	27.97
			16QAM	1	Low	21.67	26.22
				1	High	21.55	26.07
				27	Low	21.05	27.06
	20325	1747.5MHz	QPSK	1	Low	21.82	26.41
				1	High	21.91	26.36
				75	Low	21.07	27.54
			16QAM	1	Low	21.66	27.28
1				High	21.71	27.14	
27				Low	21.45	26.93	

Conducted Output Power Band 4

BW	Channel	Frequency (MHz)	Modulation	RB Size	RB Offset	Max. Avg. Power (dBm)	Peak Power (dBm)
20MHz	20050	1720.0MHz	QPSK	1	Low	22.53	27.81
				1	High	22.43	27.32
				100	Low	21.24	27.96
			16QAM	1	Low	22.45	27.39
				1	High	22.41	27.67
	20175	1732.5MHz	QPSK	27	Low	20.61	26.98
				1	Low	23.38	28.23
				1	High	22.98	27.17
			16QAM	100	Low	21.22	28.07
				1	Low	22.38	28.14
				1	High	22.24	27.91
	20300	1745.0MHz	QPSK	27	Low	21.09	27.04
				1	Low	22.76	27.23
				1	High	22.87	27.08
			16QAM	100	Low	21.03	28.14
1				Low	22.08	26.71	
1				High	22.42	27.57	
			27	Low	20.62	27.17	

Conducted Output Power Band 12

BW	Channel	Frequency	Modulation	RB Size	RB Offset	Max. Avg. Power (dBm)	Peak Power (dBm)		
5MHz	23035	701.5MHz	QPSK	1	Low	23.23	27.39		
				1	High	22.55	27.13		
				25	Low	21.78	27.81		
			16QAM	1	Low	22.35	27.01		
				1	High	21.61	26.13		
	23095	707.5MHz	QPSK	25	Low	20.95	27.41		
				1	Low	22.63	27.76		
				1	High	22.91	27.55		
			16QAM	25	Low	21.29	27.79		
				1	Low	21.61	27.69		
				1	High	21.91	27.54		
			23155	713.5MHz	QPSK	25	Low	20.56	27.39
						1	Low	23.29	27.51
						1	High	23.26	27.65
	16QAM	25			Low	21.93	27.61		
1		Low			22.53	27.62			
1	High	22.41	27.72						
25	Low	20.93	28.02						

Conducted Output Power Band 12

BW	Channel	Frequency	Modulation	RB Size	RB Offset	Max. Avg. Power (dBm)	Peak Power (dBm)
10MHz	23060	704.0MHz	QPSK	1	Low	23.03	27.95
				1	High	22.67	27.87
				50	Low	21.58	27.85
			16QAM	1	Low	22.23	26.91
				1	High	21.79	26.61
				27	Low	21.02	28.35
	23095	707.5MHz	QPSK	1	Low	23.01	27.81
				1	High	22.71	27.92
				50	Low	21.62	27.86
			16QAM	1	Low	22.22	26.88
				1	High	21.81	26.59
				27	Low	21.69	28.12
	23130	711.0MHz	QPSK	1	Low	22.77	27.34
				1	High	22.95	27.39
				50	Low	21.98	28.37
			16QAM	1	Low	22.32	26.73
				1	High	23.08	27.05
				27	Low	21.84	27.53

Band 2, Channel 18900, 1880.0 MHz, QPSK

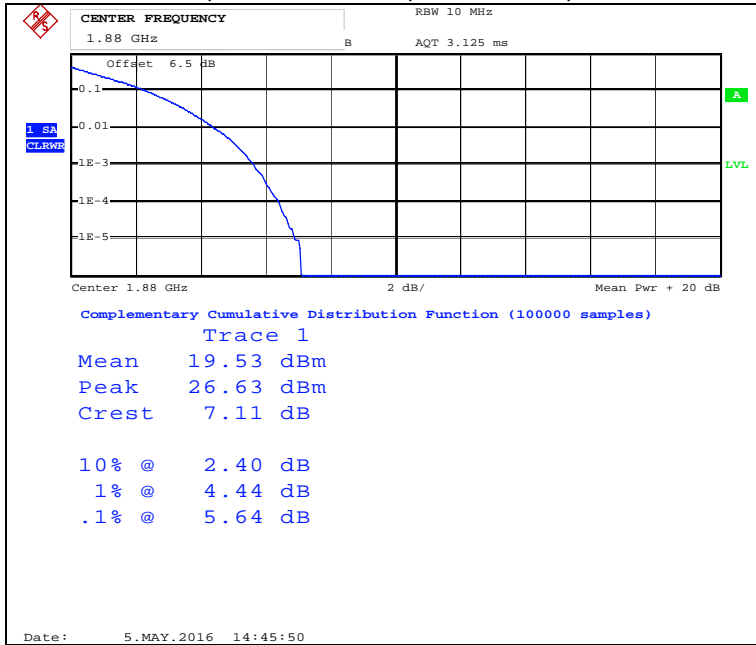

Band 2, Channel 18900, 1880.0 MHz, 16-QAM

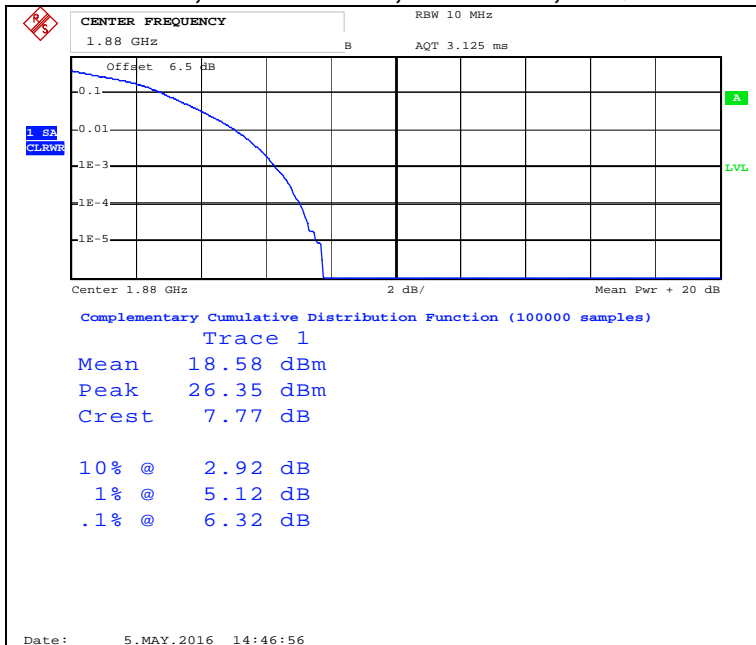

Band 4, Channel 20175, 1732.5 MHz, QPSK

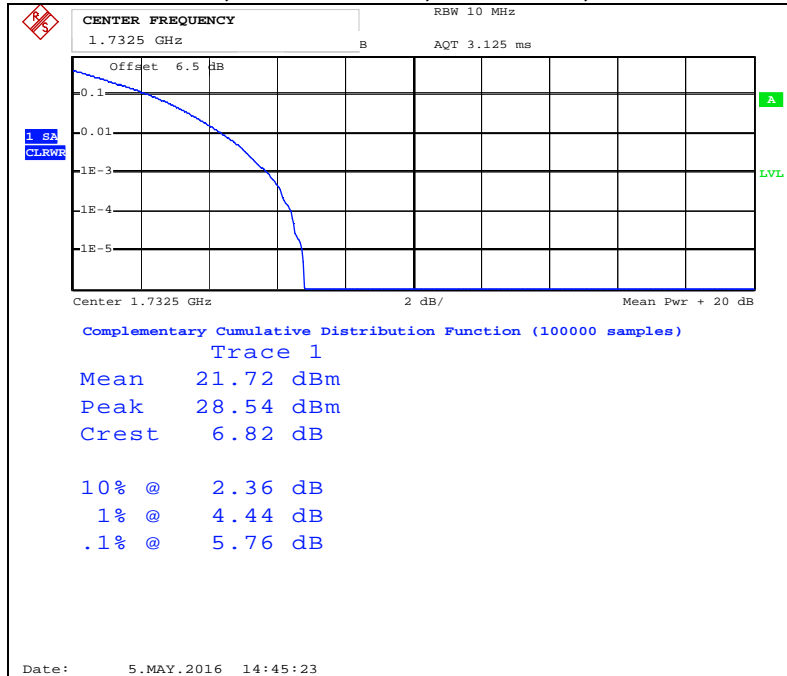

Band 4, Channel 20175, 1732.5 MHz, 16-QAM

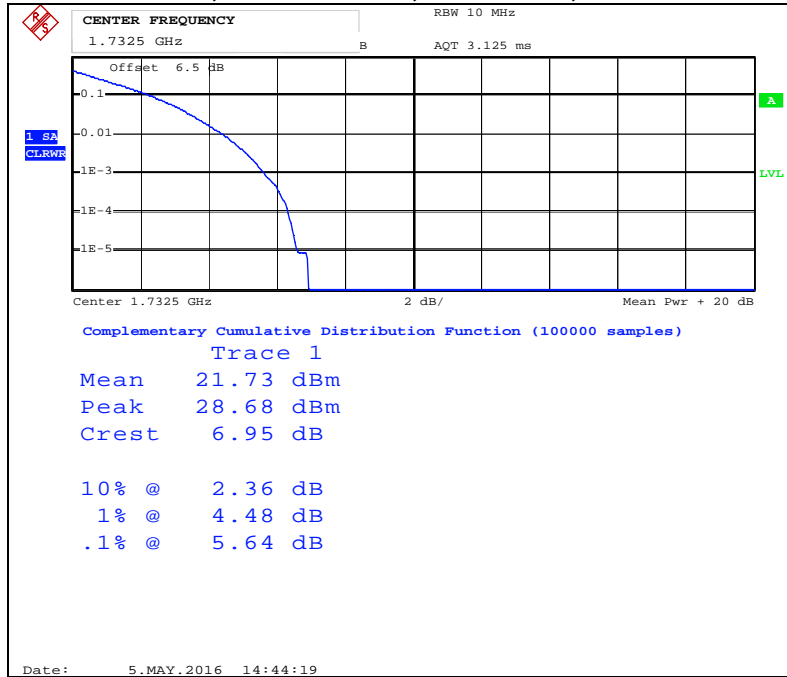

Band 12, Channel 3095, 707.5 MHz, QPSK

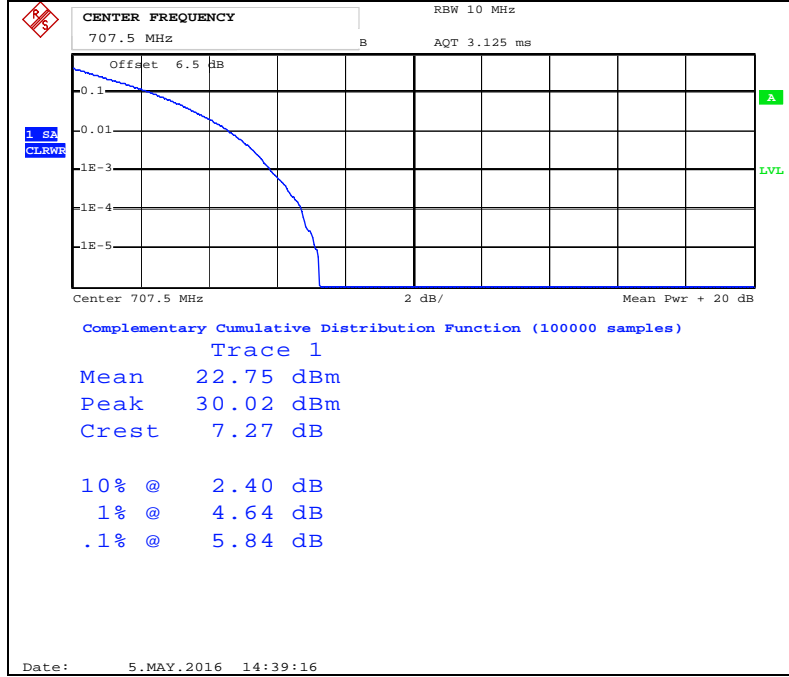

Band 12, Channel 3095, 707.5 MHz, 16-QAM

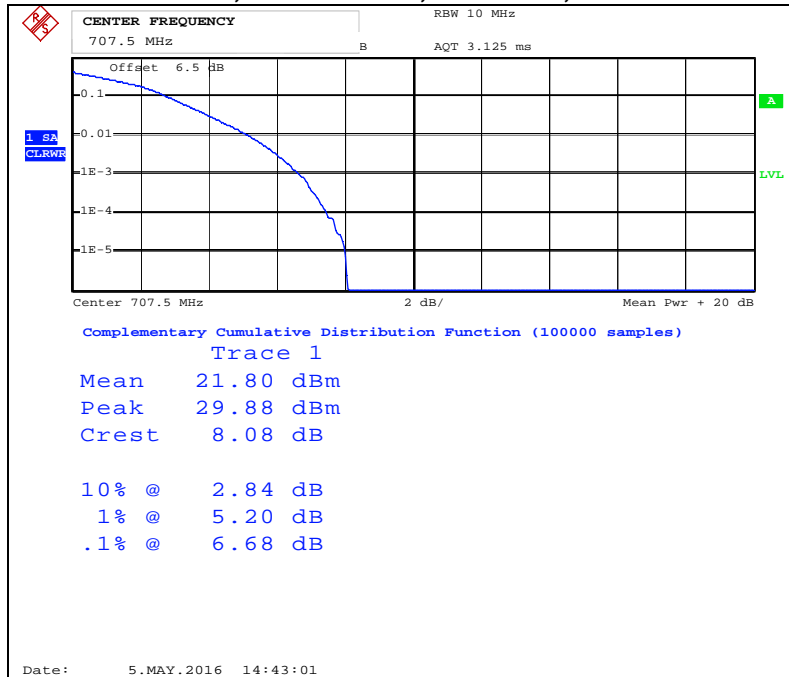

5 Occupied Bandwidth

5.1 Test Limits

§2.1049:

The occupied bandwidth is the frequency bandwidth such that, below its lower and above its upper frequency limits, the mean powers radiated are each equal to 0.5 percent of the total mean power radiated by a given emission.

5.2 Test Procedure

The EUT was connected to a spectrum analyzer using a coaxial cable and power divider. The EUT was placed into a call using base station simulator. The base station simulator was set to force the EUT to its maximum power setting. The occupied bandwidth function of the analyzer was used to automatically generate the occupied bandwidth plots. The ndB down function of the analyzer was used to automatically measure the 26dB emission bandwidth. A peak detector was used for this measurement.

5.3 Test Equipment Used:

Description	Serial Number	Manufacturer	Model	Cal. Date	Cal. Due
Base Station Simulator	3917	Rohde & Schwarz	CMW500	9/19/2015	9/19/2016
Spectrum Analyzer	3099	Rohde & Schwarz	FSP7	9/18/2015	9/18/2016
Power Divider	E18106	Weinschell Engineering	1506A	Time of Use	Time of Use

5.4 Results:

The bandwidth measurements are shown in the table below and the plots that follow.

Occupied Bandwidth Data

Band	Frequency (MHz)	Channel	BW (MHz)	# RB	Mode	-26dBm Occupied Bandwidth (MHz)	99% Occupied Bandwidth (MHz)	Figure Number
B2	1880.0	18900	5	25	QPSK	5.67	4.55	1
					16-QAM	5.35	4.55	2
			10	50	QPSK	9.88	9.00	3
					27	16-QAM	6.20	4.92
			15	75	QPSK	14.52	13.44	5
					27	16-QAM	6.06	4.96
			20	100	QPSK	19.36	17.92	7
					27	16-QAM	5.92	4.96
B4	1732.5	20175	5	25	QPSK	5.42	4.58	9
					16-QAM	5.20	4.56	10
			10	50	QPSK	10.16	9.00	11
					27	16-QAM	6.04	4.92
			15	75	QPSK	14.16	13.44	13
					27	16-QAM	6.00	4.92
			20	100	QPSK	19.20	17.84	15
					27	16-QAM	5.84	4.88
B12	707.5	23095	5	25	QPSK	5.76	4.56	17
					16-QAM	5.26	4.56	18
			10	50	QPSK	9.52	8.96	19
					27	16-QAM	5.56	4.92

Figure 1: Band 2, BW=5MHz, QPSK

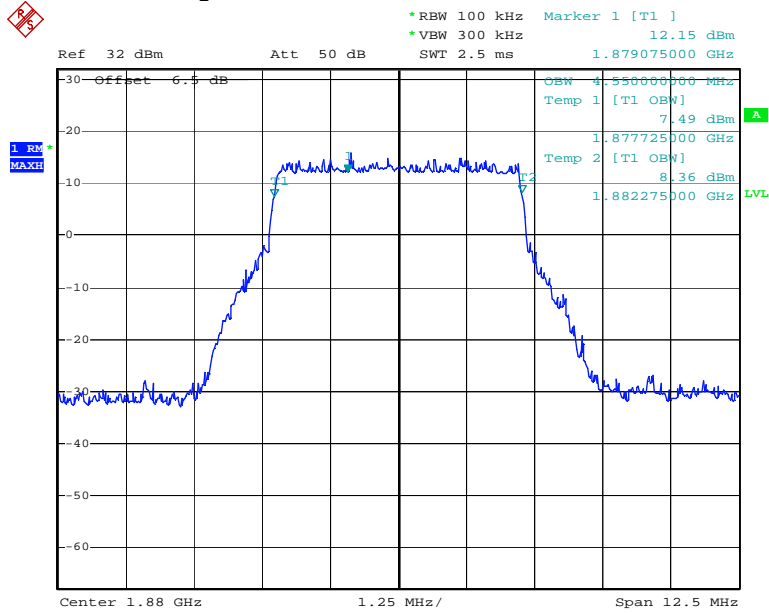

Date: 5.MAY.2016 09:58:09

Figure 2: Band 2, BW=5MHz, 16-QAM

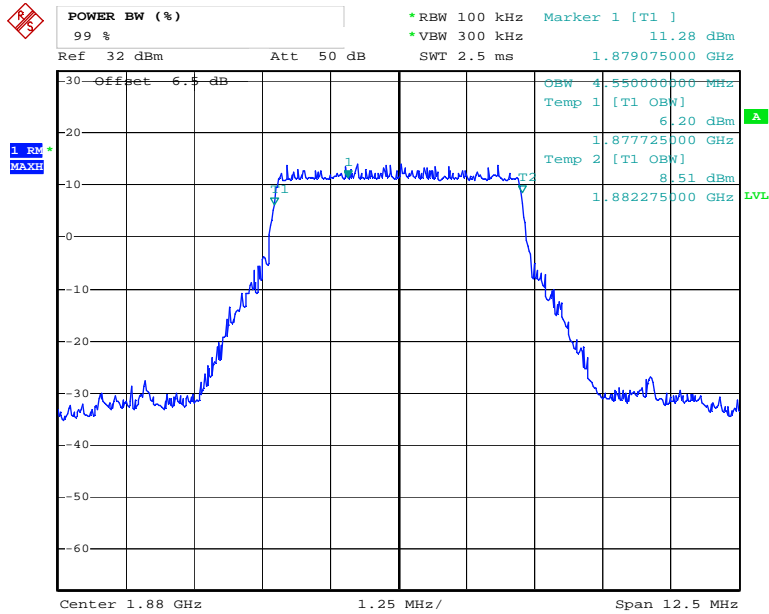

Date: 5.MAY.2016 09:59:43

Figure 3: Band 2, BW=10MHz, QPSK

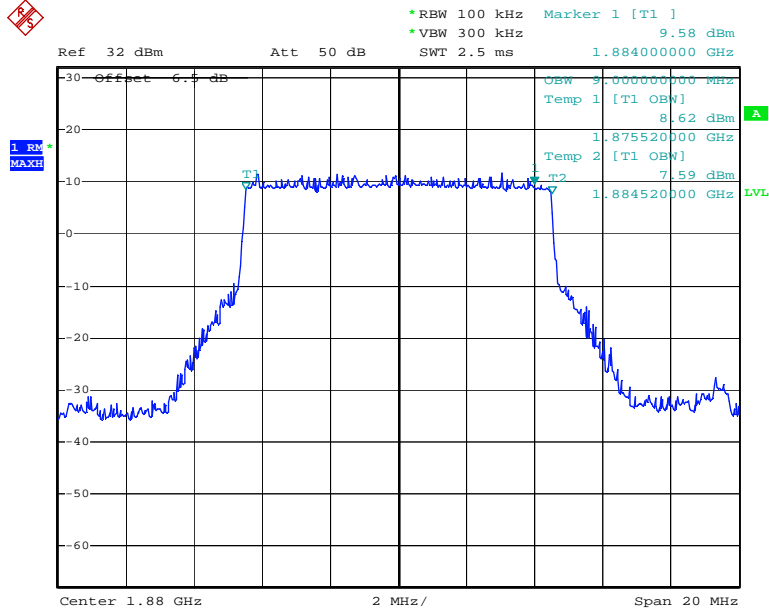

Date: 5.MAY.2016 10:01:09

Figure 4: Band 2, BW=10MHz, 16-QAM (27 RB, Low and High)

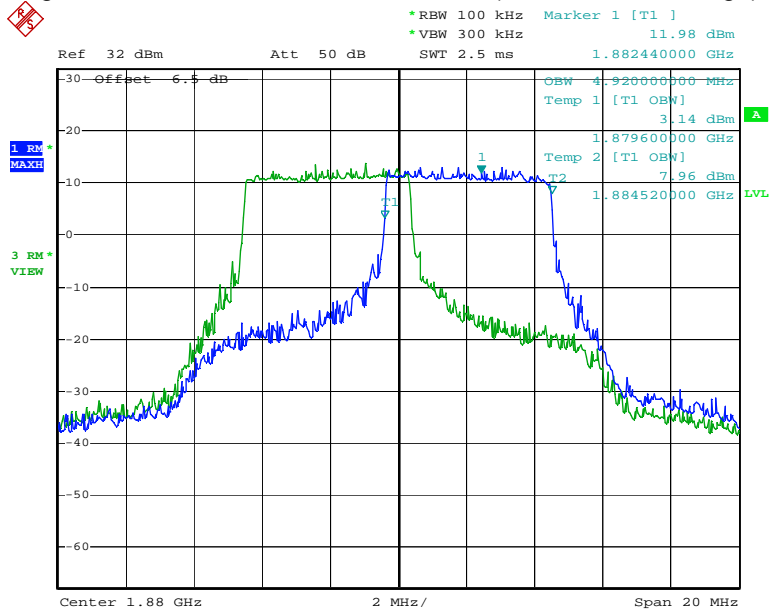

Date: 5.MAY.2016 10:37:26

Figure 5: Band 2, BW=15MHz, QPSK

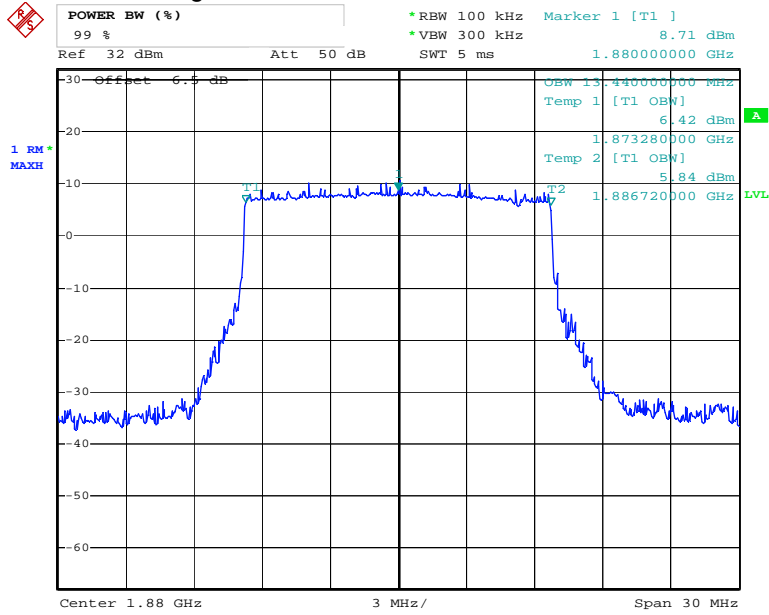

Date: 5.MAY.2016 10:39:10

Figure 6: Band 2, BW=15MHz, 16-QAM (27 RB, Low, Mid, and High)

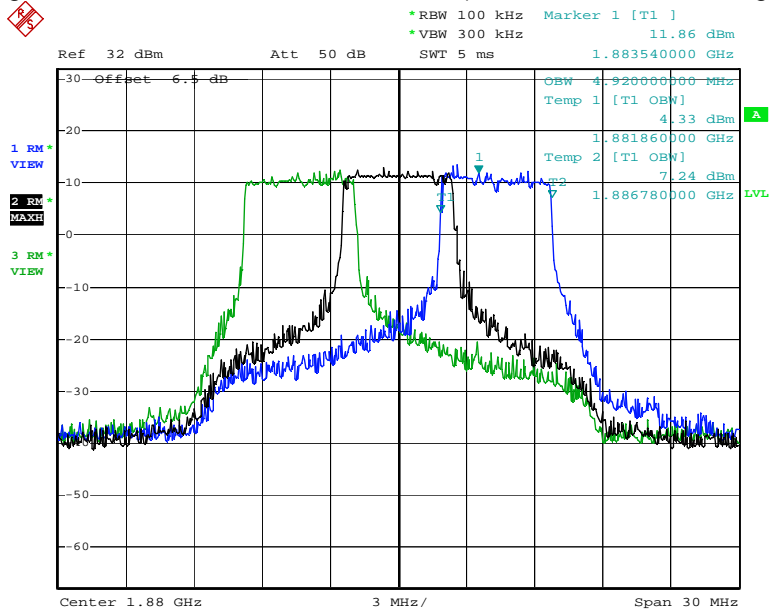

Date: 5.MAY.2016 10:50:44

Figure 7: Band 2, BW=20MHz, QPSK

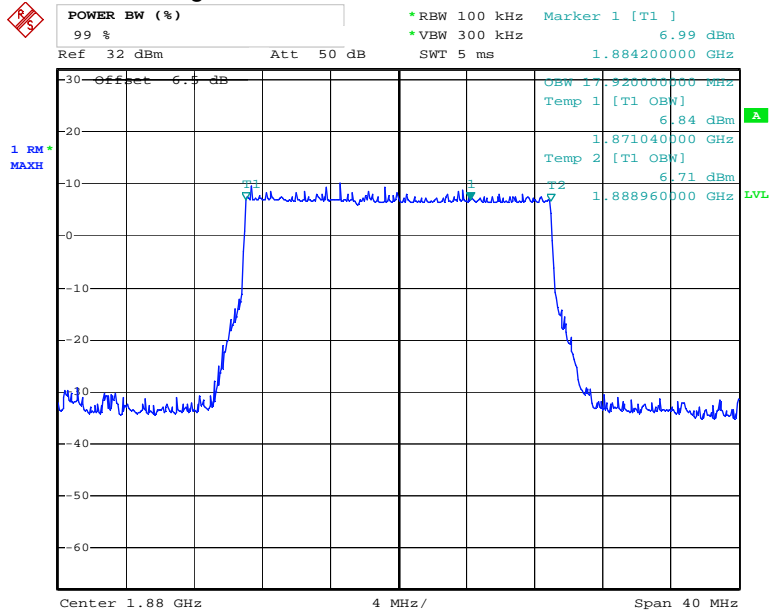

Date: 5.MAY.2016 10:43:49

Figure 8: Band 2, BW=20MHz, 16-QAM (27 RB, Low, Mid, and High)

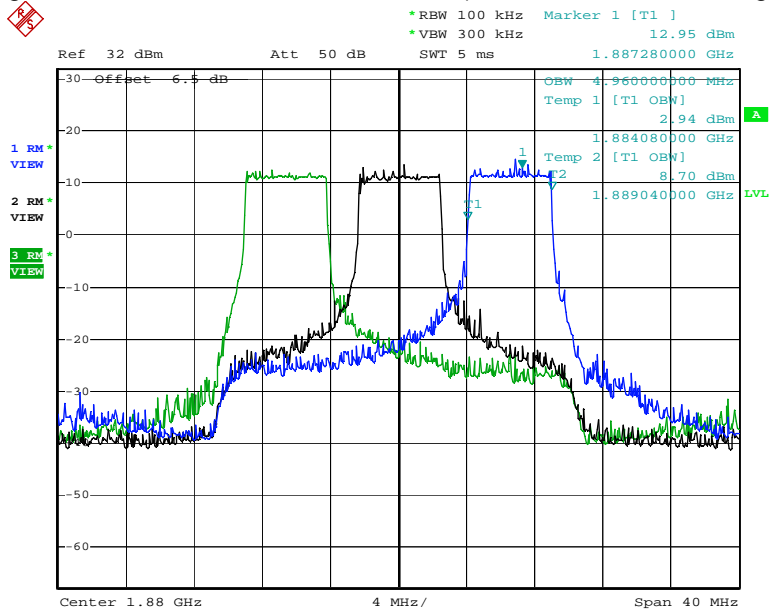

Date: 5.MAY.2016 10:47:42

Figure 9: Band 4, BW=5MHz, QPSK

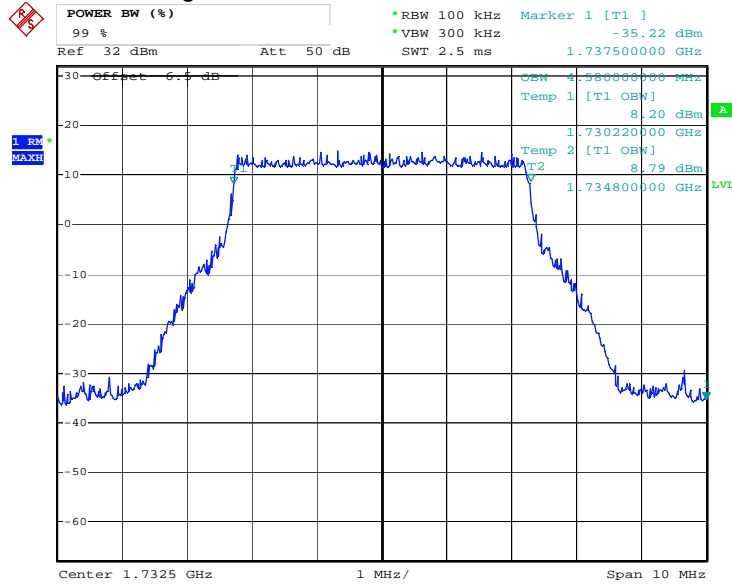

Date: 5.MAY.2016 10:57:28

Figure 10: Band 4, BW=5MHz, 16-QAM

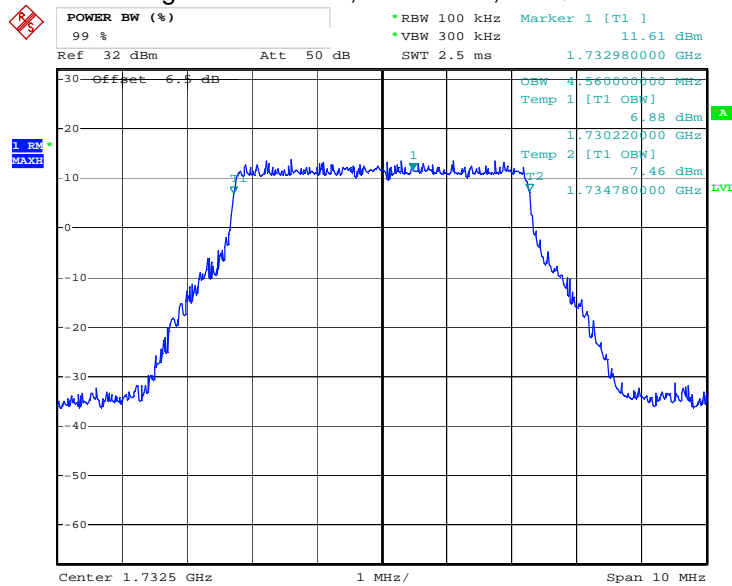

Date: 5.MAY.2016 10:58:31

Figure 11: Band 4, BW=10MHz, QPSK

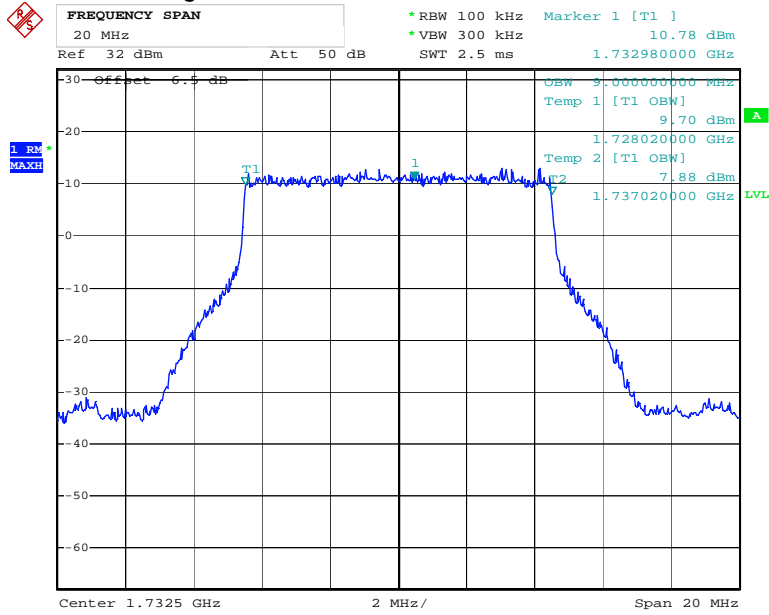

Date: 5.MAY.2016 11:04:23

Figure 12: Band 4, BW=10MHz, 16-QAM (27 RB, Low and High)

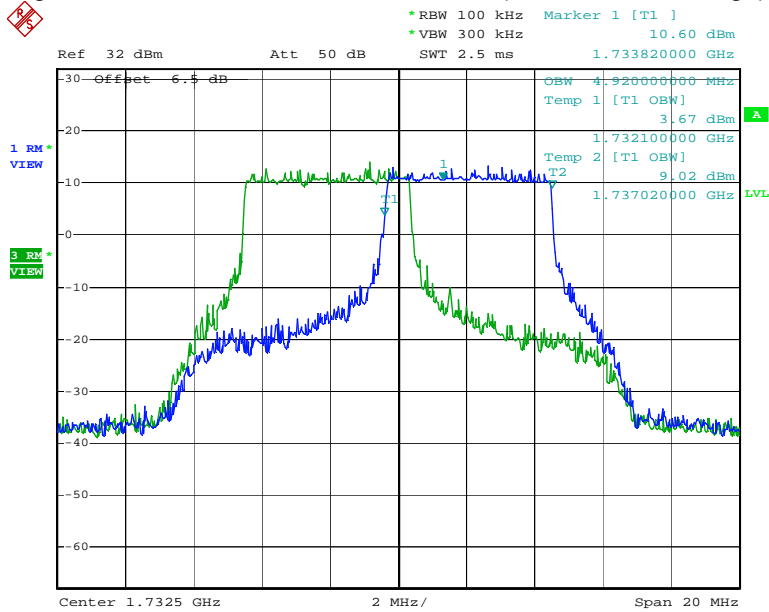

Date: 5.MAY.2016 11:07:58

Figure 13: Band 4, BW=15MHz, QPSK

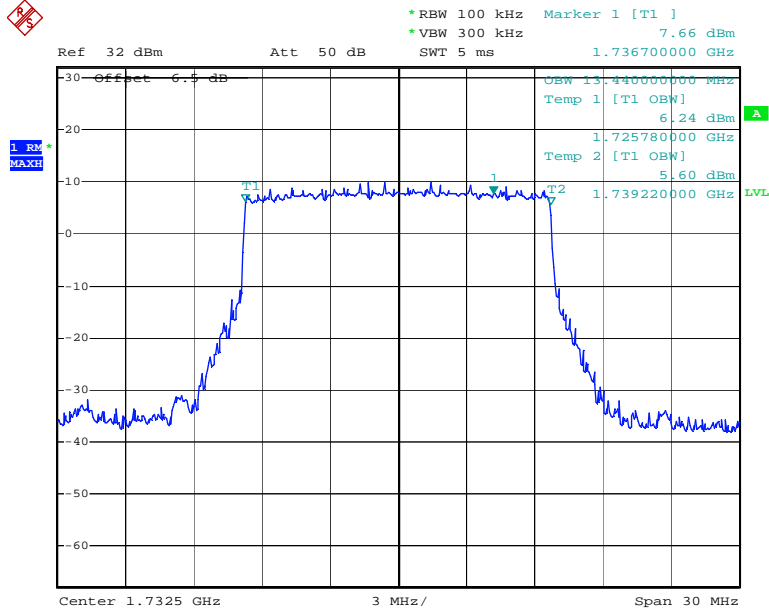

Date: 5.MAY.2016 11:13:26

Figure 14: Band 4, BW=15MHz, 16-QAM (27 RB, Low, Mid, and High)

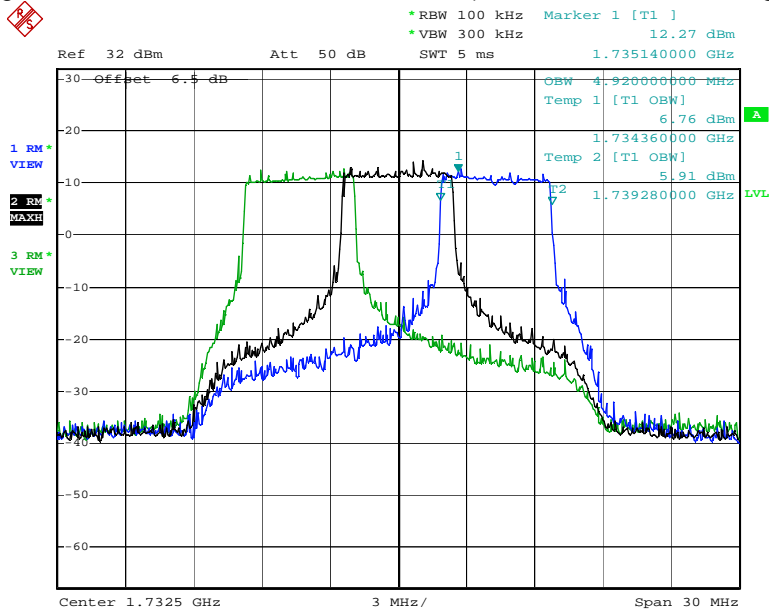

Date: 5.MAY.2016 11:10:49

Figure 15: Band 4, BW=20MHz, QPSK

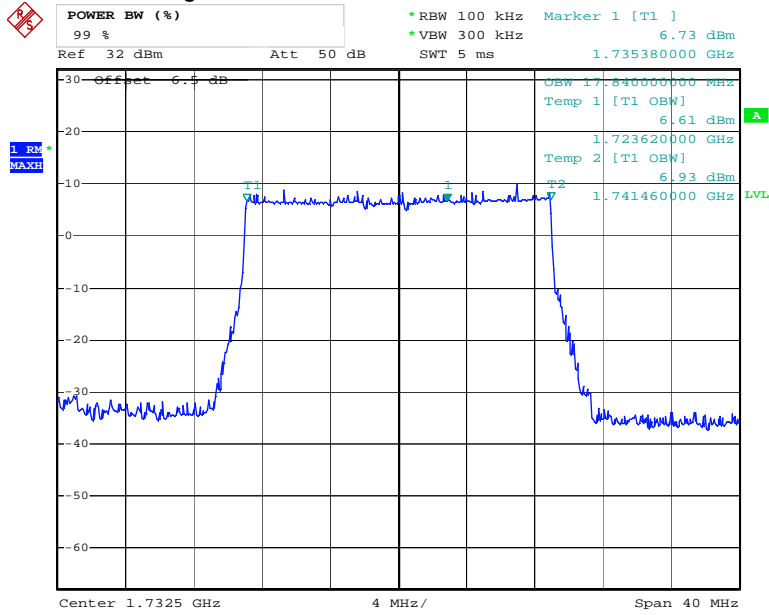

Date: 5.MAY.2016 11:14:43

Figure 16: Band 4, BW=20MHz, 16-QAM (27 RB, Low, Mid, and High)

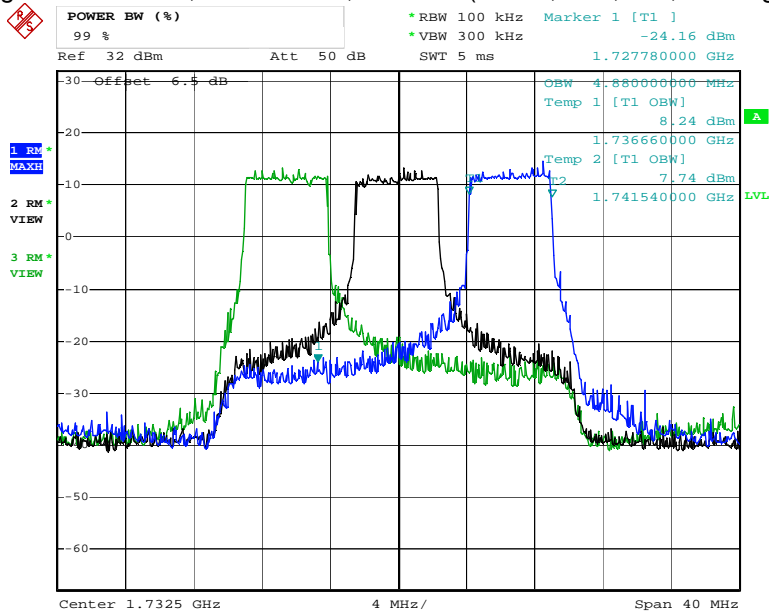

Date: 5.MAY.2016 11:17:02

Figure 17: Band 12, BW=5MHz, QPSK

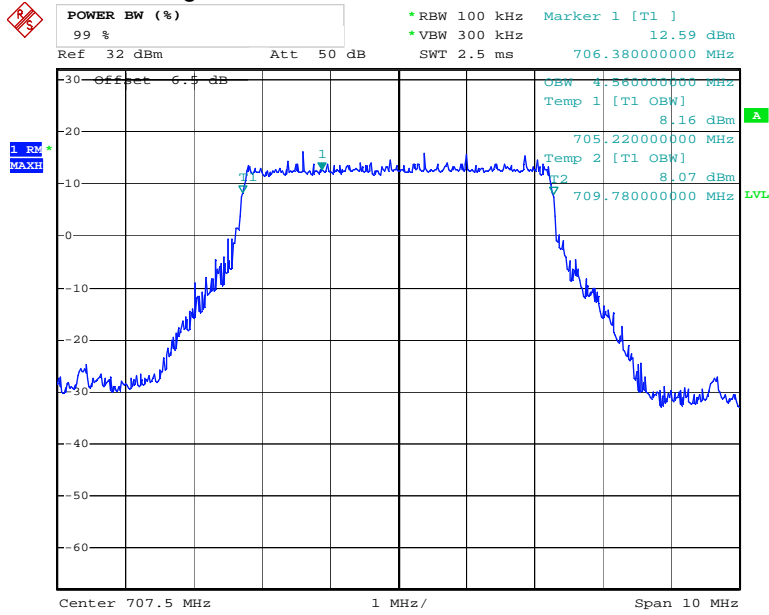

Date: 5.MAY.2016 11:22:10

Figure 18: Band 12, BW=5MHz, 16-QAM

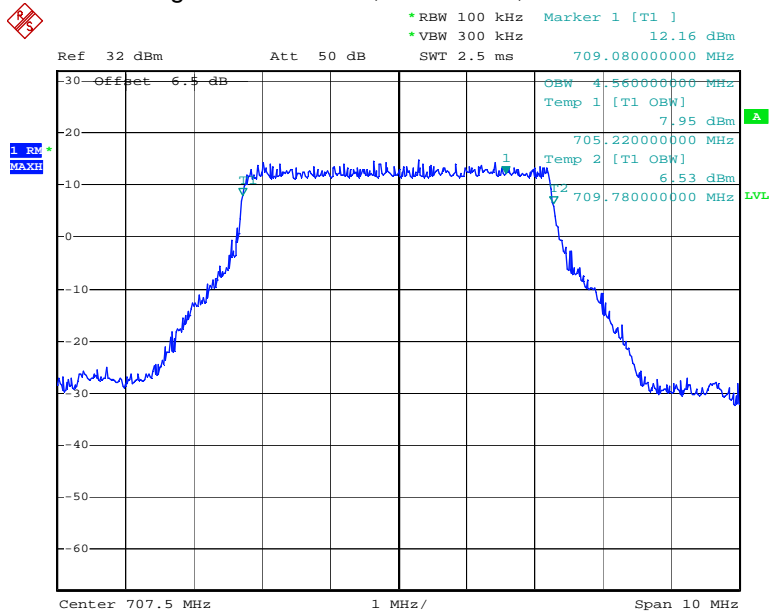

Date: 5.MAY.2016 11:21:23

Figure 19: Band 12, BW=10MHz, QPSK

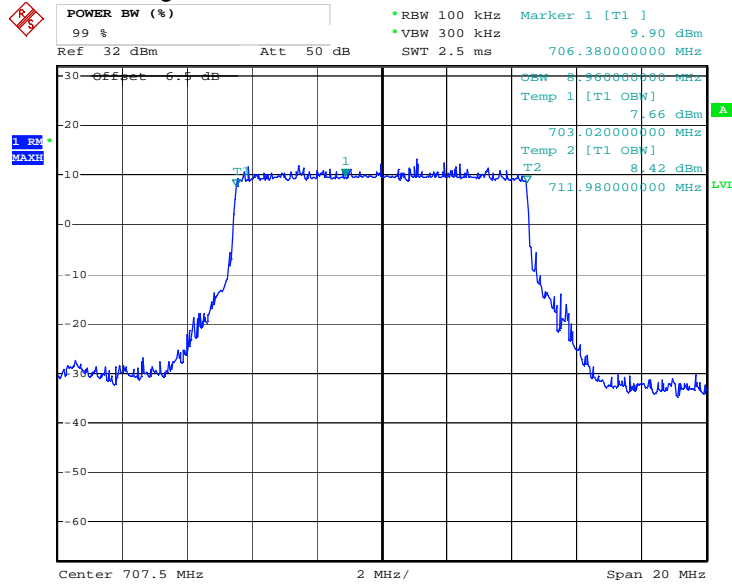

Date: 5.MAY.2016 11:25:27

Figure 20: Band 12, BW=10MHz, 16-QAM (27 RB, Low and High)

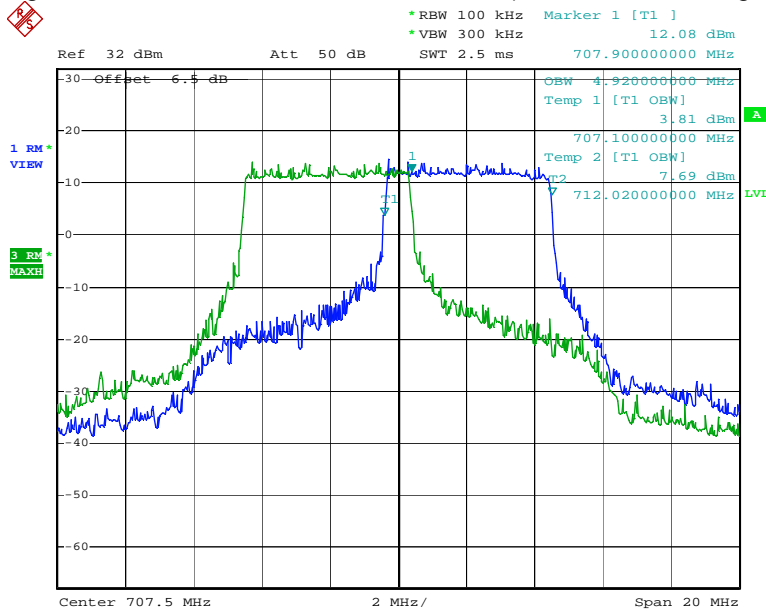

Date: 5.MAY.2016 11:26:40

6 Conducted Spurious Emissions at Antenna Terminals

6.1 Test Limits

§ 2.1051

The radio frequency voltage or powers generated within the equipment and appearing on a spurious frequency shall be checked at the equipment output terminals when properly loaded with a suitable artificial antenna. Curves or equivalent data shall show the magnitude of each harmonic and other spurious emission that can be detected when the equipment is operated under the conditions specified in §2.1049 as appropriate. The magnitude of spurious emissions which are attenuated more than 20 dB below the permissible value need not be specified.

§ 24.238

- (a) Out of band emissions. The power of any emission outside of the authorized operating frequency ranges must be attenuated below the transmitting power (P) by a factor of at least $43 + 10 \log(P)$ dB.
- (b) Measurement procedure. Compliance with these rules is based on the use of measurement instrumentation employing a resolution bandwidth of 1 MHz or greater. However, in the 1 MHz bands immediately outside and adjacent to the frequency block a resolution bandwidth of at least one percent of the emission bandwidth of the fundamental emission of the transmitter may be employed. A narrower resolution bandwidth is permitted in all cases to improve measurement accuracy provided the measured power is integrated over the full required measurement bandwidth (i.e. 1 MHz or 1 percent of emission bandwidth, as specified). The emission bandwidth is defined as the width of the signal between two points, one below the carrier center frequency and one above the carrier center frequency, outside of which all emissions are attenuated at least 26 dB below the transmitter power.

§ 27.53

- (g) For operations in the 600 MHz band and the 698-746 MHz band, the power of any emission outside a licensee's frequency band(s) of operation shall be attenuated below the transmitter power (P) within the licensed band(s) of operation, measured in watts, by at least $43 + 10 \log(P)$ dB. Compliance with this provision is based on the use of measurement instrumentation employing a resolution bandwidth of 100 kilohertz or greater. However, in the 100 kilohertz bands immediately outside and adjacent to a licensee's frequency block, a resolution bandwidth of at least 30 kHz may be employed.
- (h) *AWS emission limits—(1) General protection levels.* Except as otherwise specified below, for operations in the 1695-1710 MHz, 1710-1755 MHz, 1755-1780 MHz, 1915-1920 MHz, 1995-2000 MHz, 2000-2020 MHz, 2110-2155 MHz, 2155-2180 MHz, and 2180-2200 bands, the power of any emission outside a licensee's frequency block shall be attenuated below the transmitter power (P) in watts by at least $43 + 10 \log_{10}(P)$ dB.

6.2 Test Procedure

The RF output of the EUT was connected to a spectrum analyzer through appropriate attenuation. The base station simulator was set to force the EUT to its maximum power setting. The resolution bandwidth of the spectrum analyzer was set at 100kHz or 1MHz depending on the transmit band and the detector was set to peak detection for general scans up to the 10th harmonic. Emissions scans near the fundamental were measured using an RMS detector. Sufficient scans were taken to show the out of band Emissions if any up to 10th harmonic.

6.3 Test Equipment Used:

Description	Serial Number	Manufacturer	Model	Cal. Date	Cal. Due
Base Station Simulator	3917	Rohde & Schwarz	CMW500	9/19/2015	9/19/2016
Spectrum Analyzer	3099	Rohde & Schwarz	FSP7	9/18/2015	9/18/2016
Spectrum Analyzer	3720	Rohde & Schwarz	FSEK30	9/19/2015	9/19/2016
Power Divider	E18106	Weinschell Engineering	1506A	Time of Use	Time of Use

6.4 Results:

The following plots show that all spurious emissions are attenuated below the transmitting power (P) by a factor of at least $43 + 10 \log(P)$ dB. Plots for emissions within 1MHz of the transmit block edge as well as for emission outside of this range are shown.

Band 2, BW=5MHz, QPSK and 16-QAM

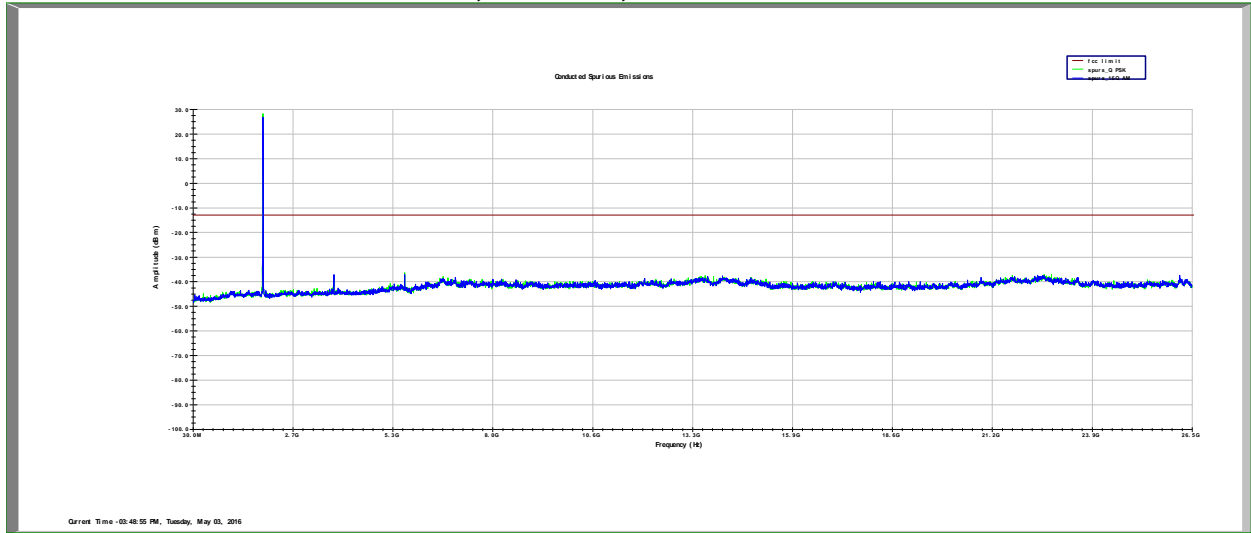

Band 2, BW=10MHz, QPSK and 16-QAM

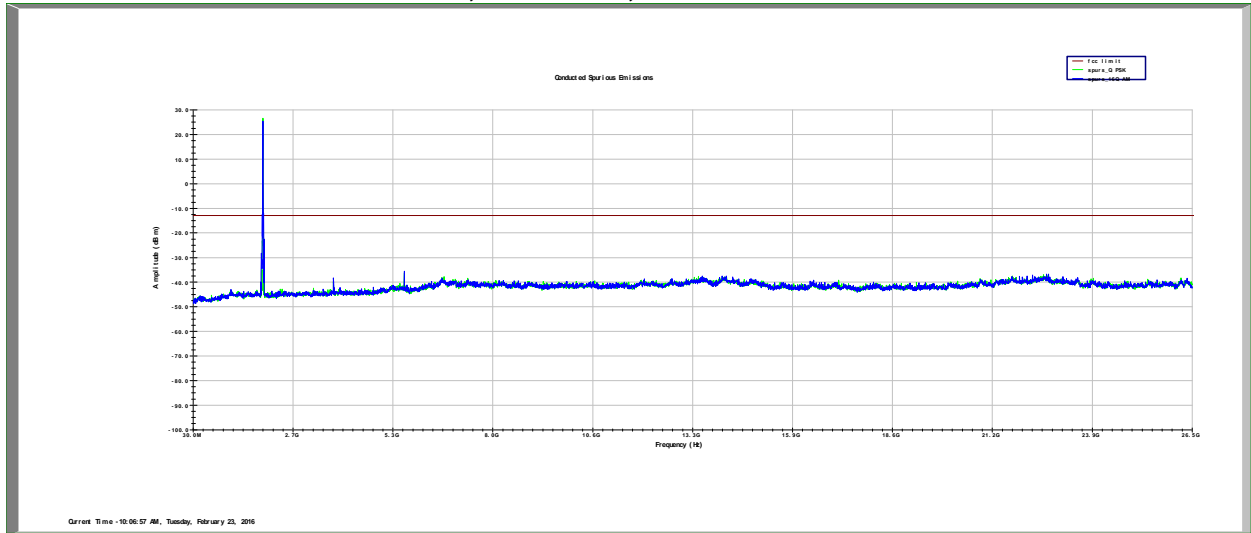

Band 2, BW=15MHz, QPSK and 16-QAM

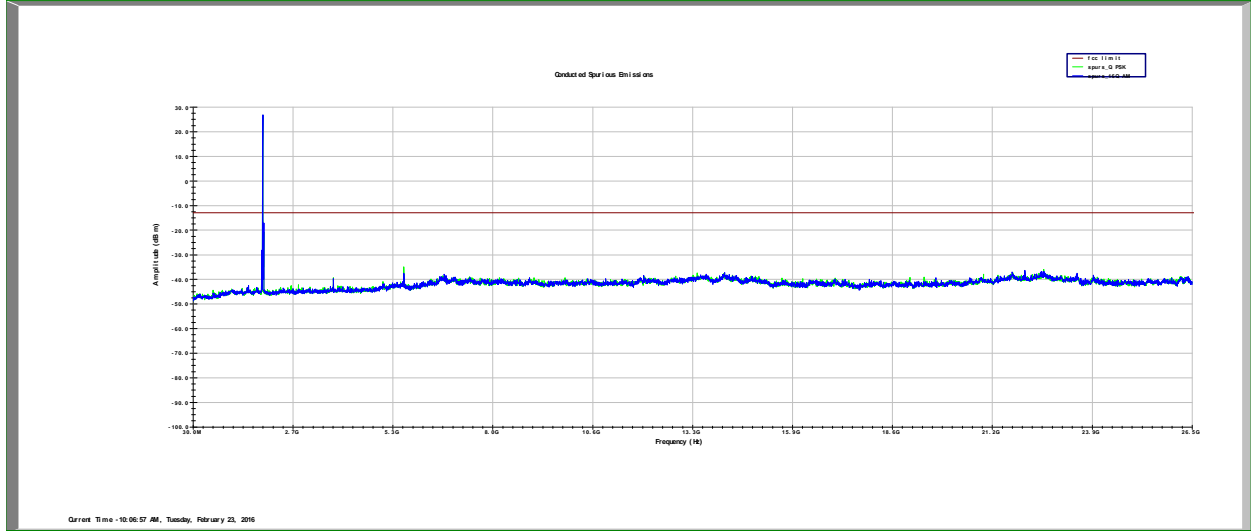

Band 2, BW=20MHz, QPSK and 16-QAM

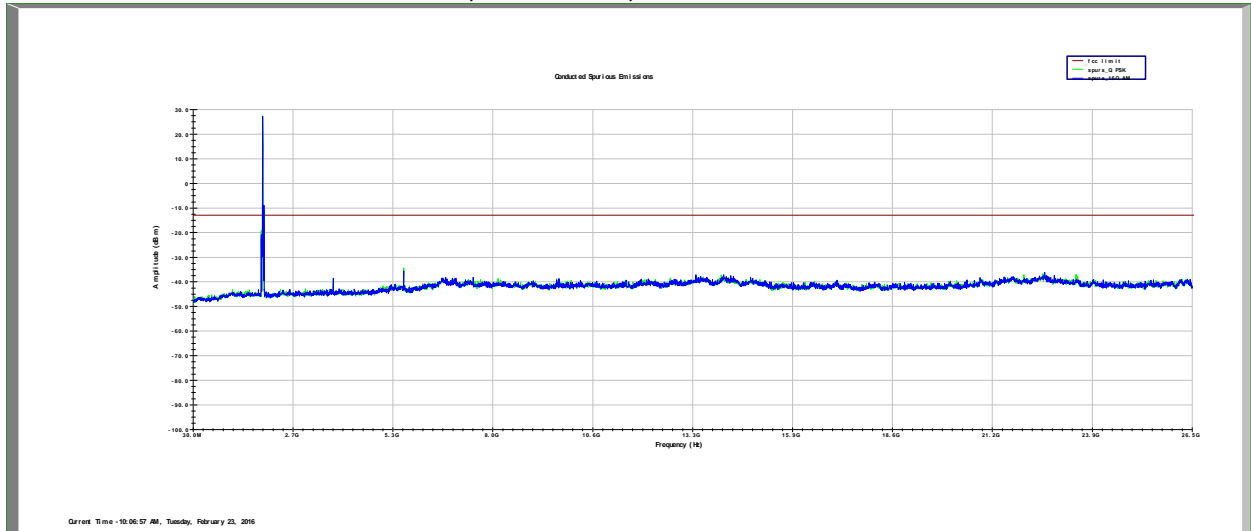

Band 4, BW=5MHz, QPSK and 16-QAM

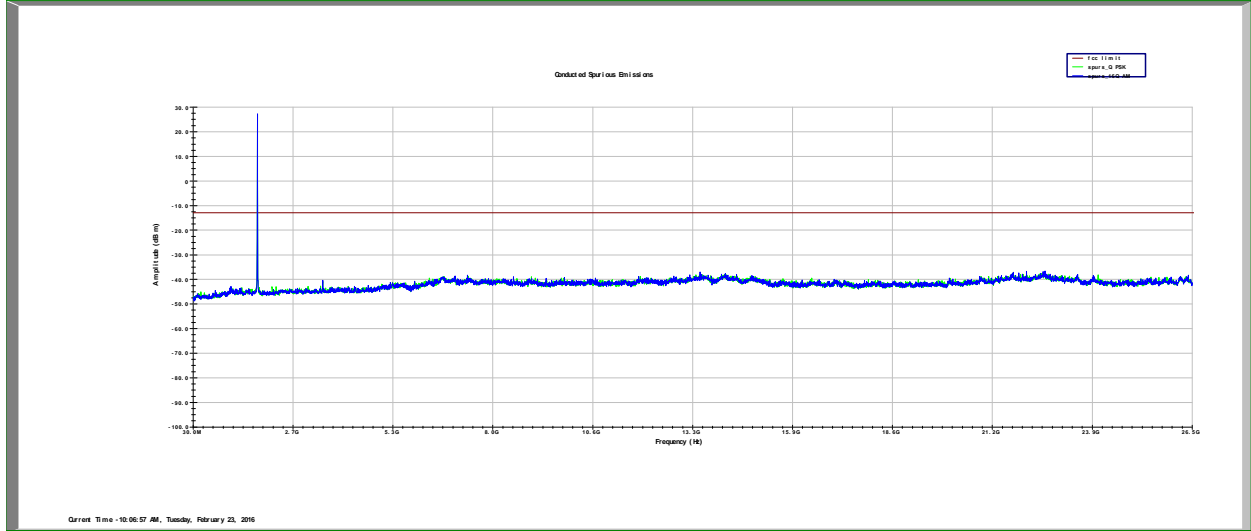

Band 4, BW=10MHz, QPSK and 16-QAM

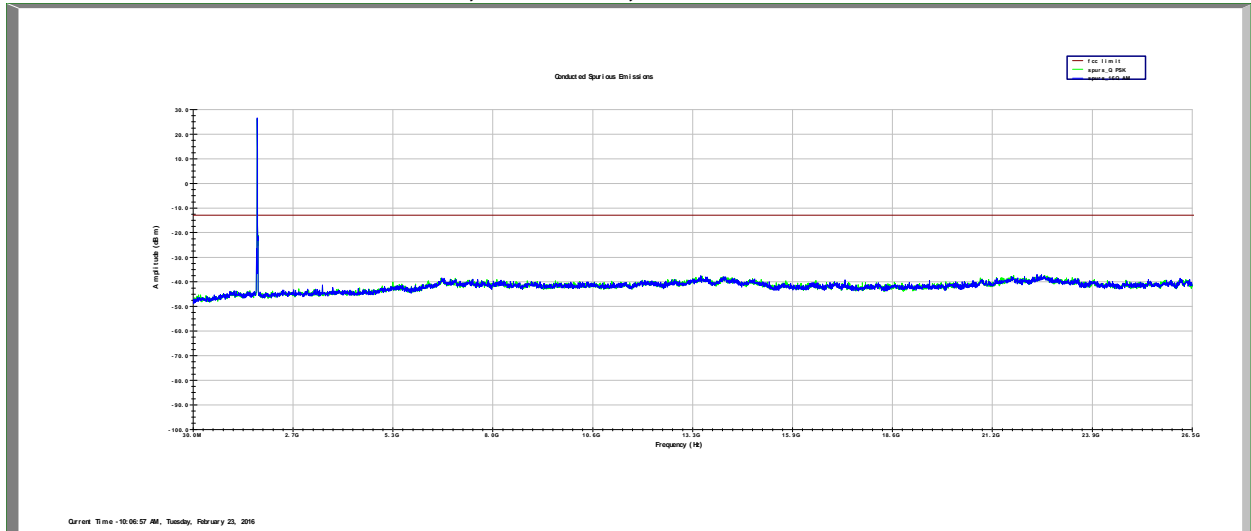

Band 4, BW=15MHz, QPSK and 16-QAM

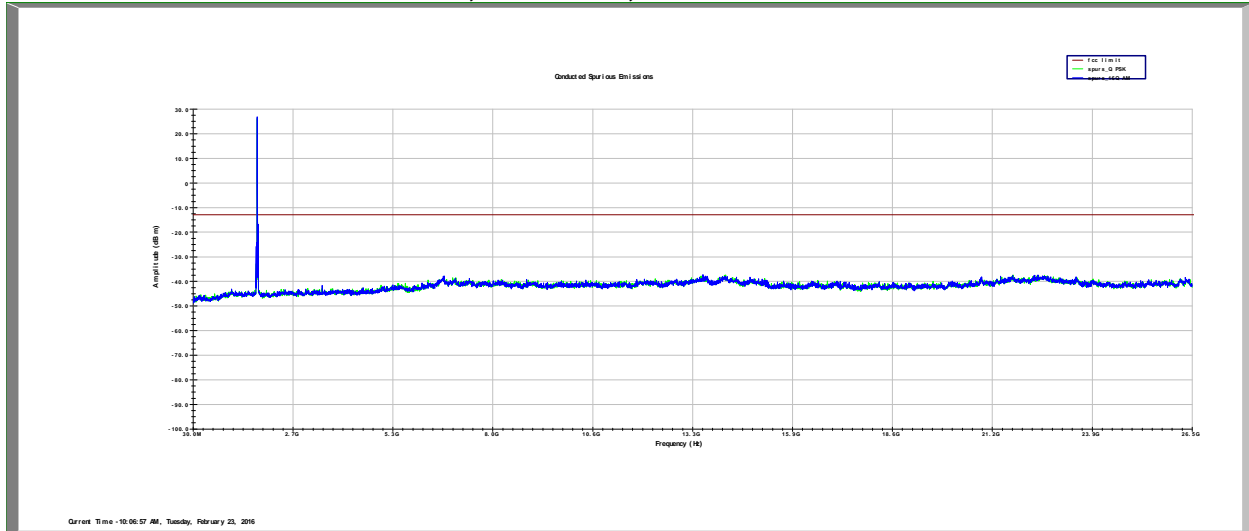

Band 4, BW=20MHz, QPSK and 16-QAM

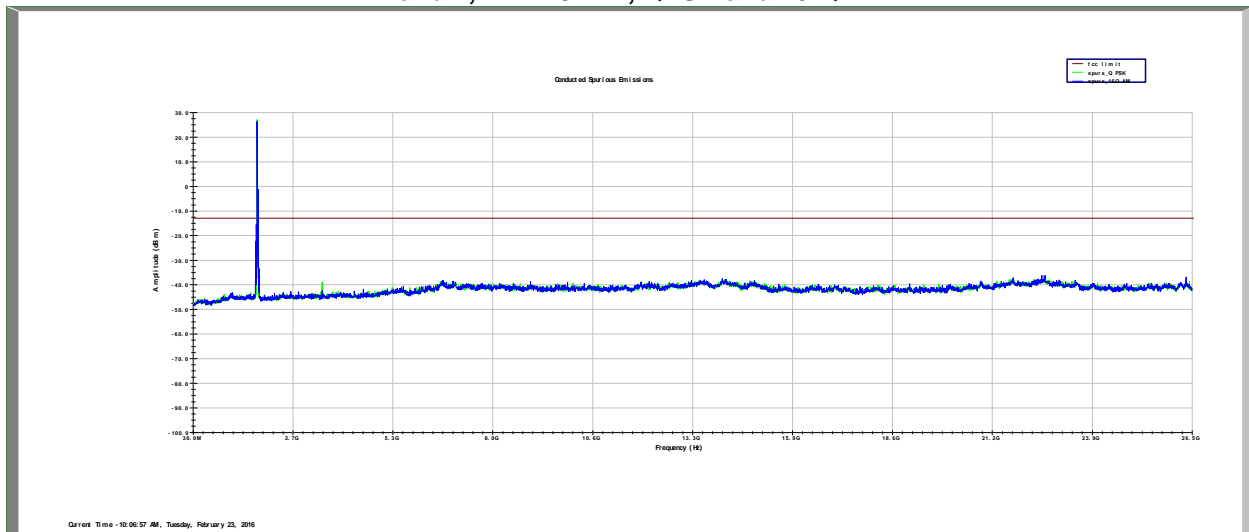

Band 12, BW=5MHz, QPSK and 16-QAM

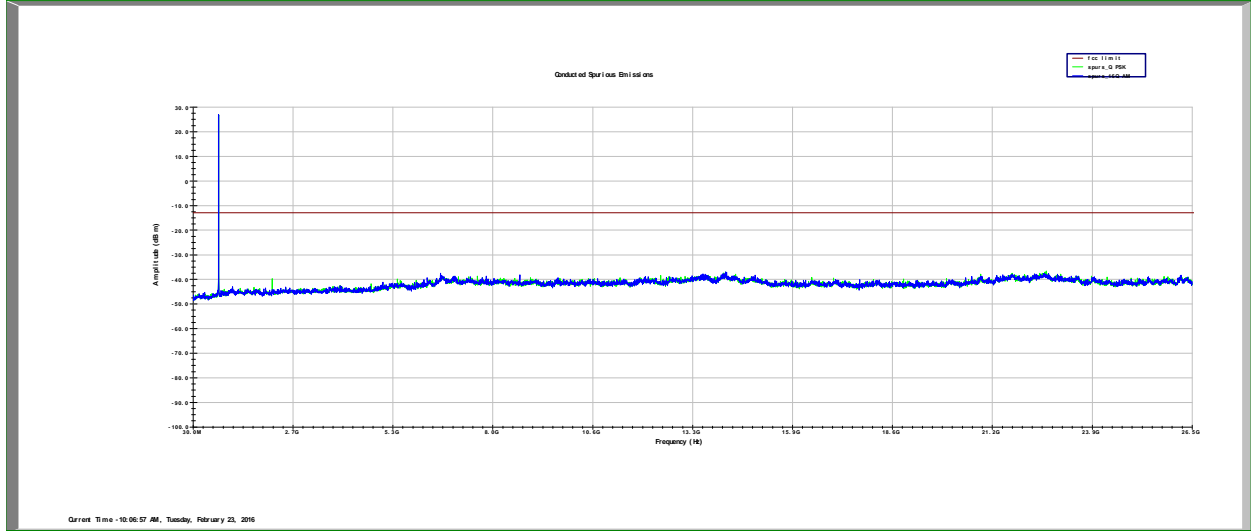

Band 12, BW=10MHz, QPSK and 16-QAM

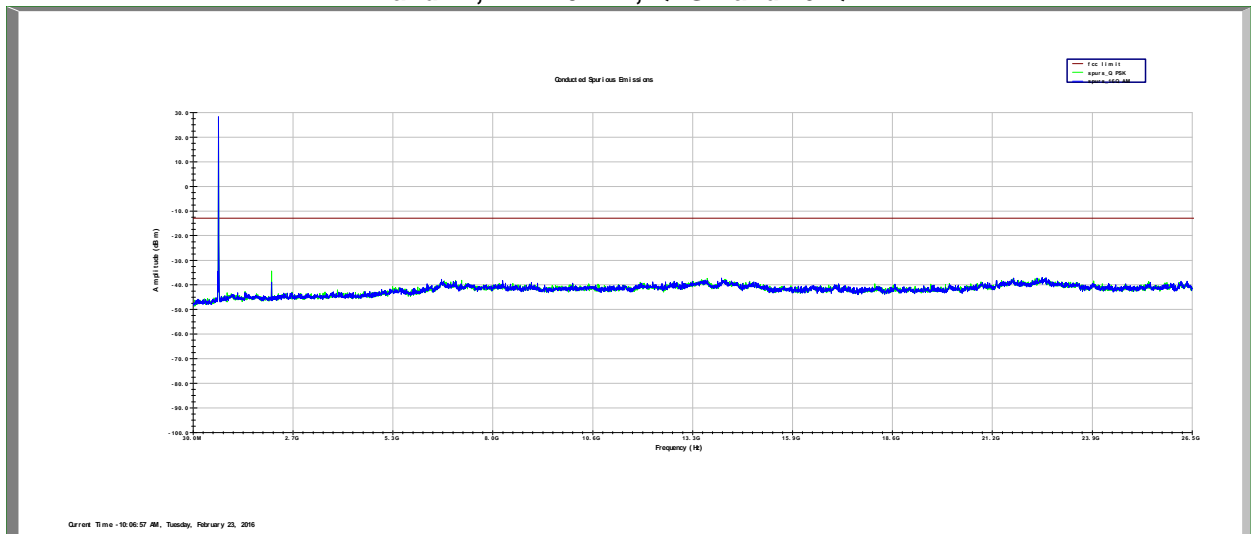

Band 2, 5 MHz BW, QPSK

Channel 18625, 1852.5 MHz
Below 1850 MHz

Channel 19175, 1907.5 MHz
Above 1910 MHz

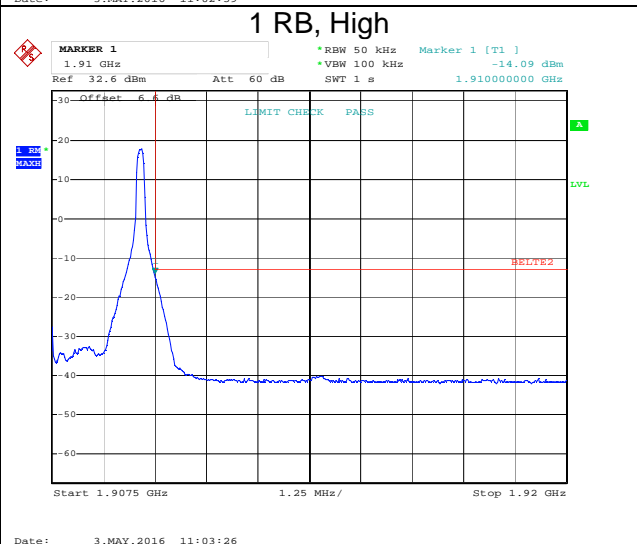
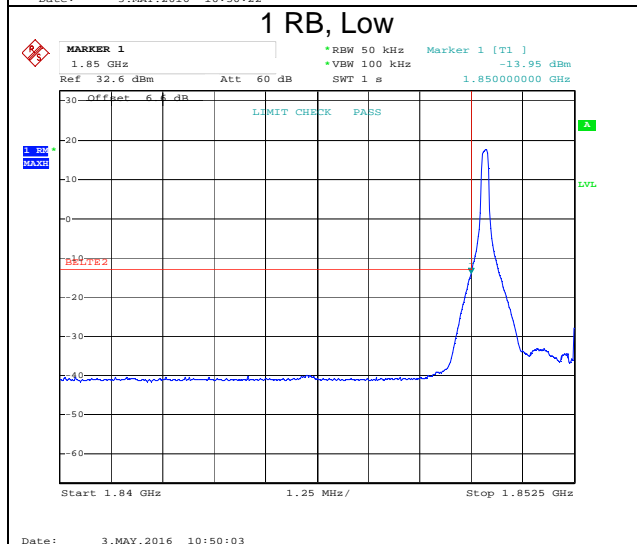
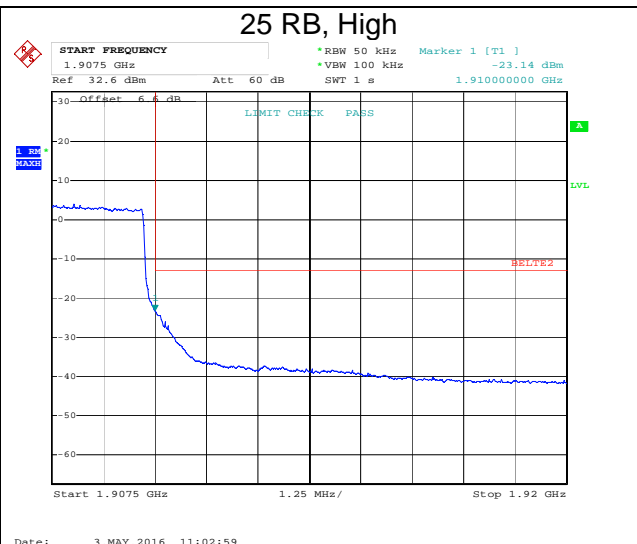
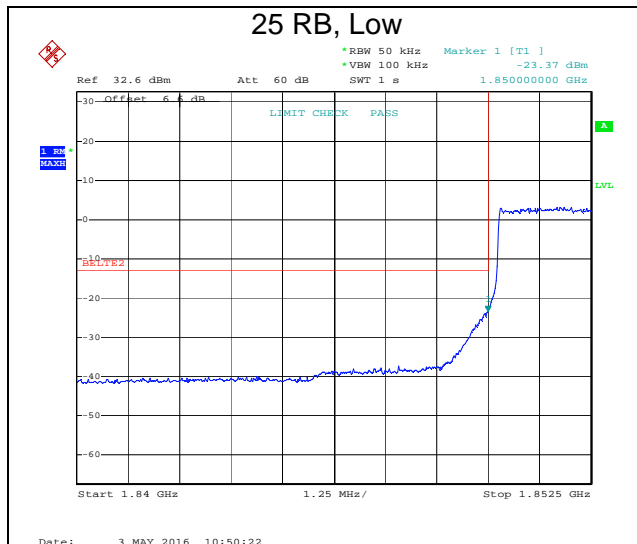

Band 2, 5 MHz BW, 16-QAM

Channel 18625, 1852.5 MHz
Below 1850 MHz

Channel 19175, 1907.5 MHz
Above 1910 MHz

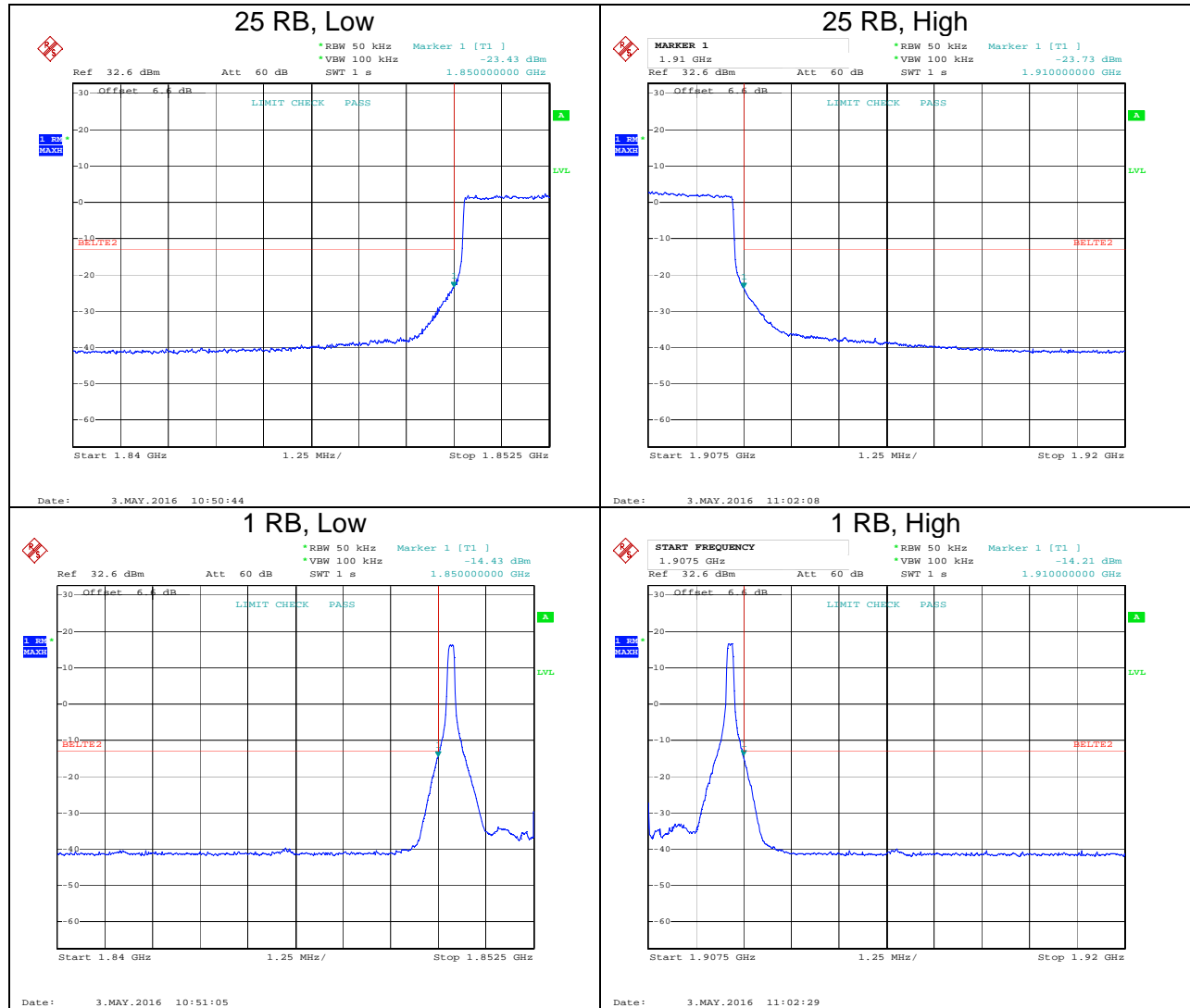

Band 2, 10 MHz BW, QPSK

Channel 18650, 1855.0 MHz Below 1850 MHz	Channel 19150, 1905.0 MHz Above 1910 MHz
---	---

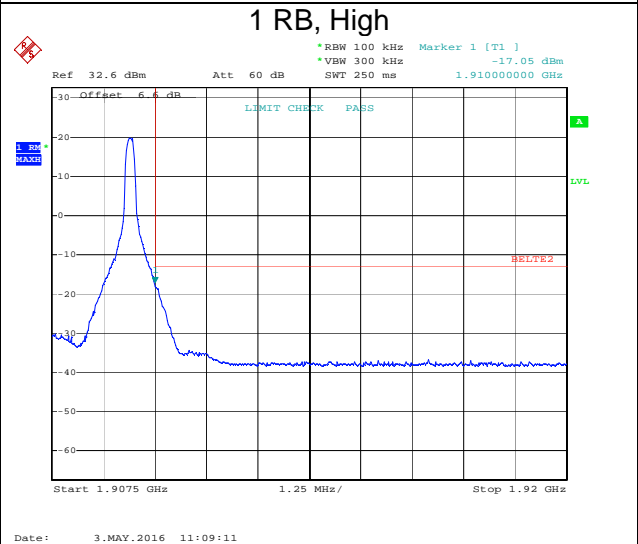
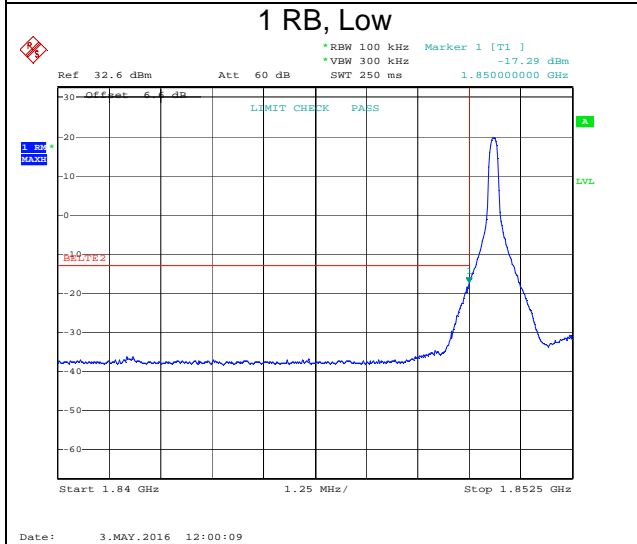
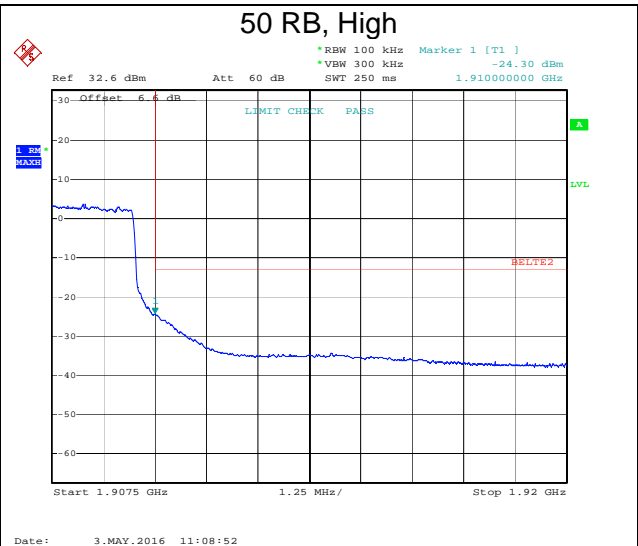
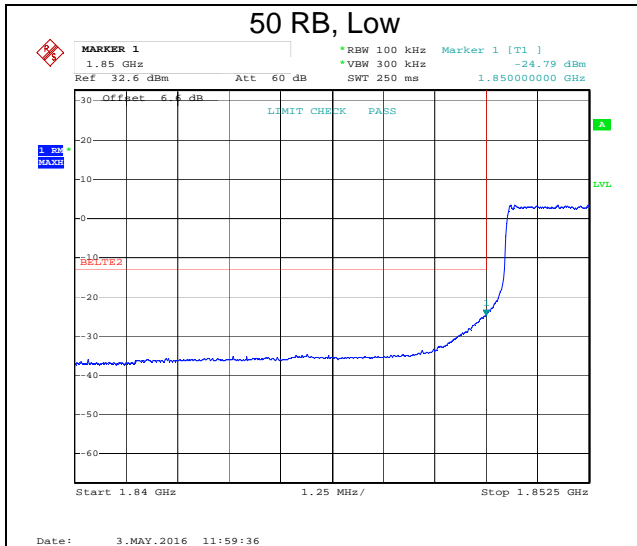

Band 2, 10 MHz BW, 16-QAM

Channel 18650, 1855.0 MHz Below 1850 MHz	Channel 19150, 1905.0 MHz Above 1910 MHz
---	---

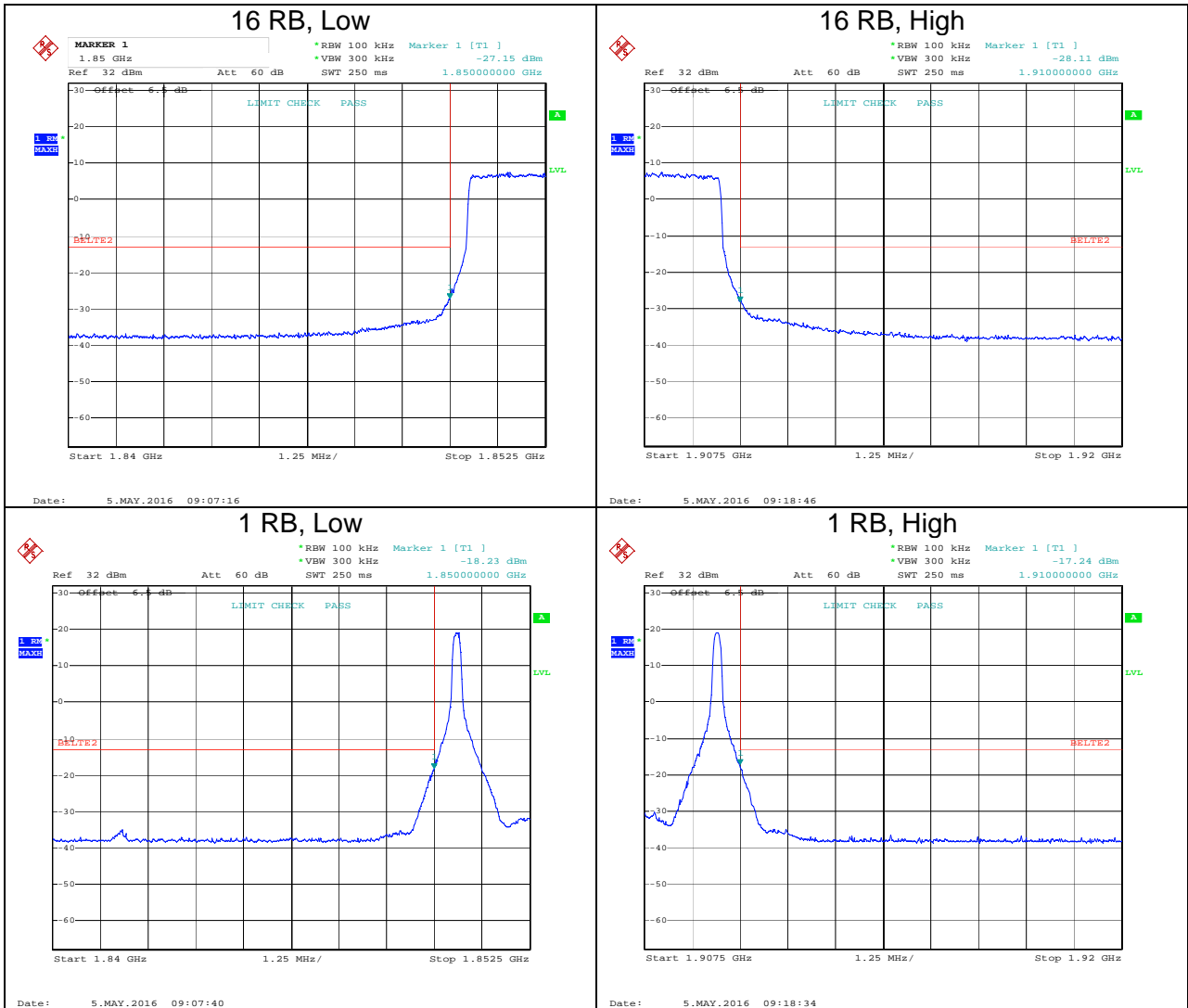

Band 2, 15 MHz BW, QPSK

Channel 18675, 1857.2 MHz Below 1850 MHz	Channel 19125, 1902.5 MHz Above 1910 MHz
---	---

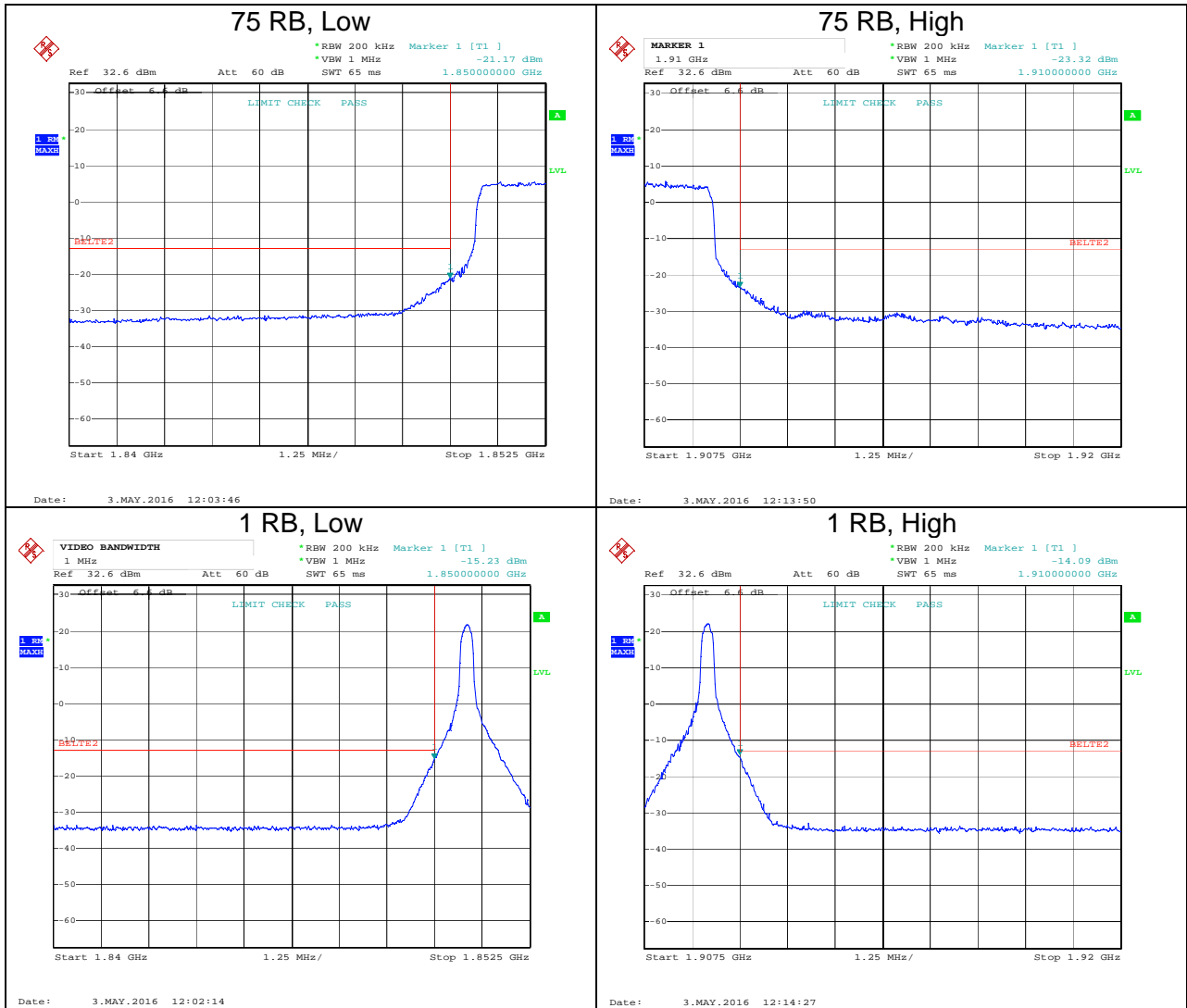

Band 2, 15 MHz BW, 16-QAM

Channel 18675, 1857.2 MHz
Below 1850 MHz

Channel 1902.5, 19125 MHz
Above 1910 MHz

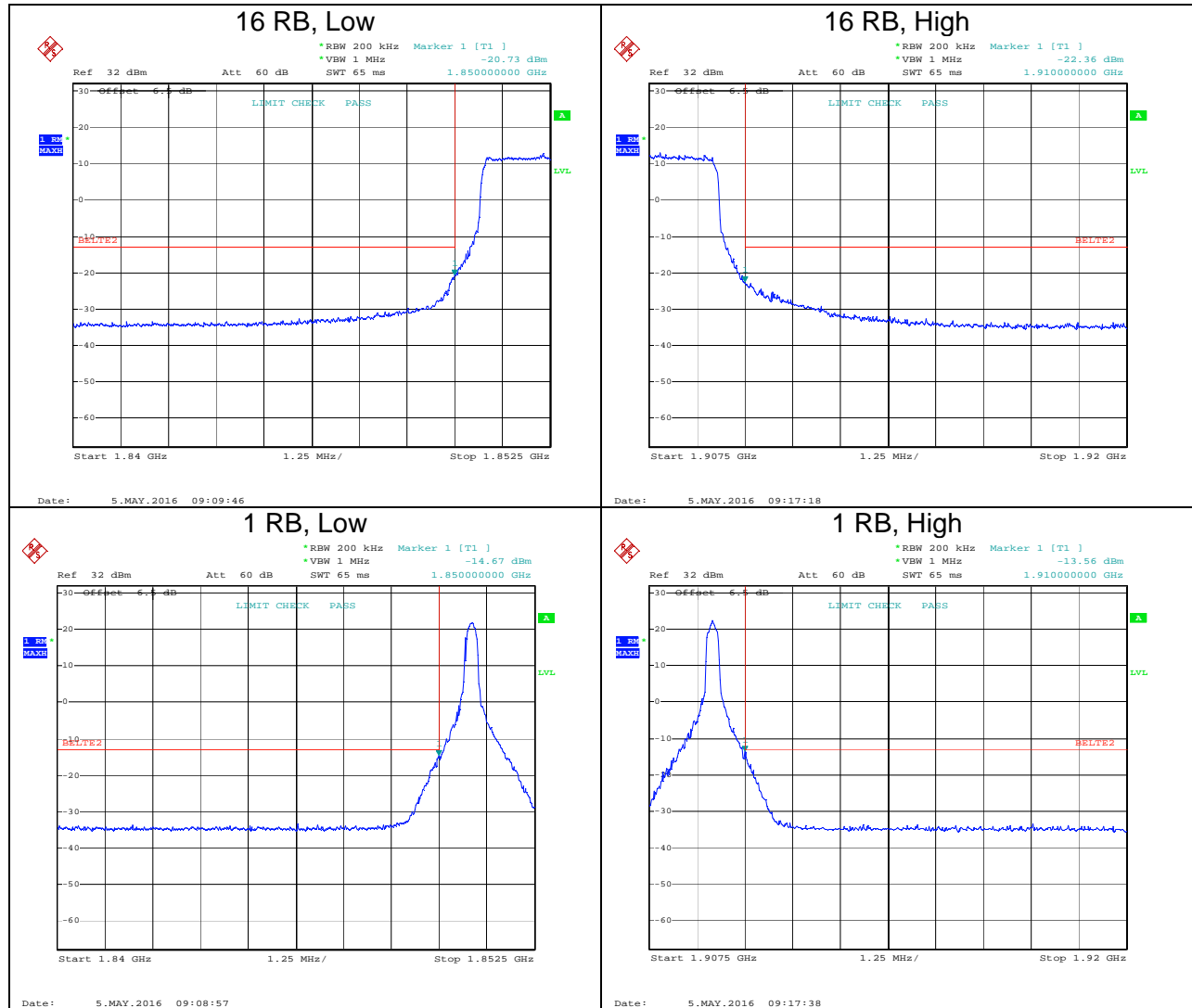

Band 2, 20 MHz BW, QPSK

Channel 18700, 1860.0 MHz Below 1850 MHz	Channel 19100, 1900.0 MHz Above 1910 MHz
---	---

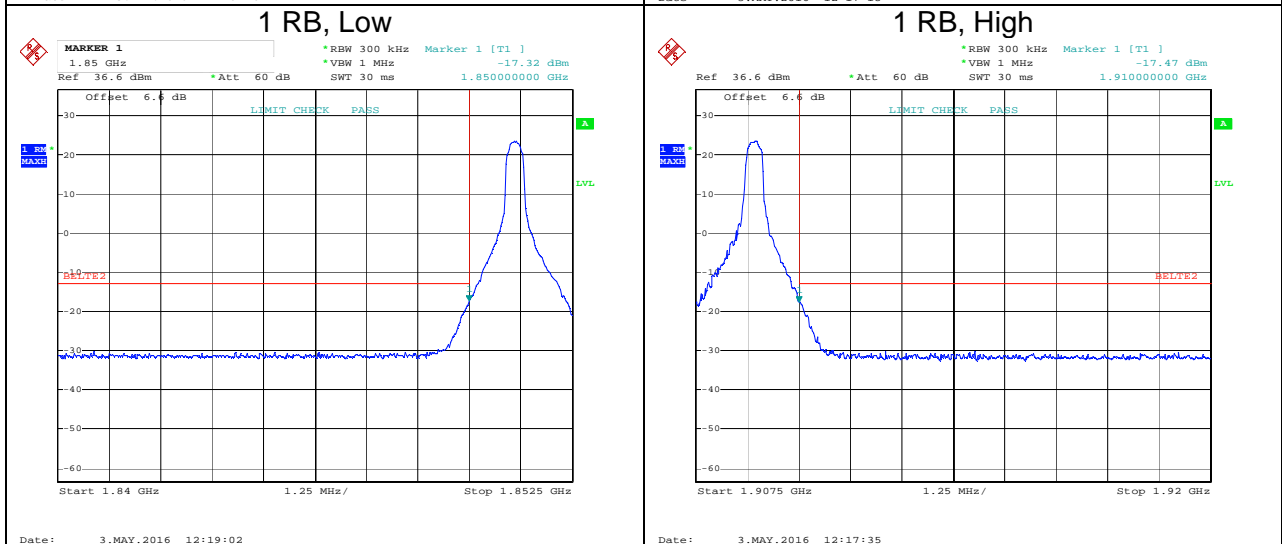
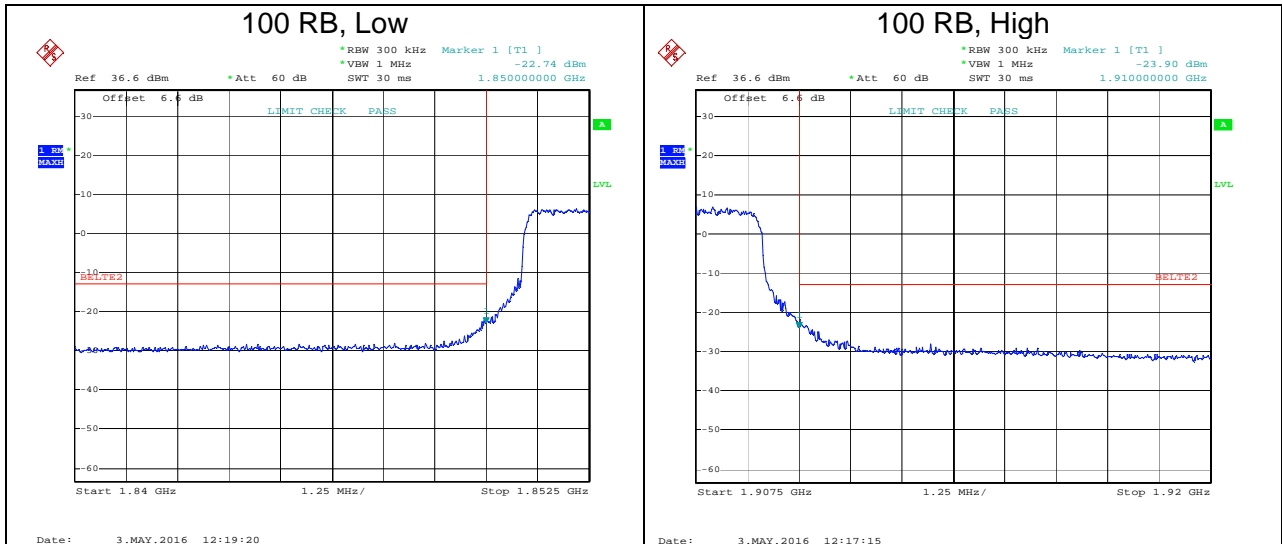

Band 2, 20 MHz BW, 16-QAM

Channel 18700, 1860.0 MHz Below 1850 MHz	Channel 19100, 1900.0 MHz Above 1910 MHz
---	---

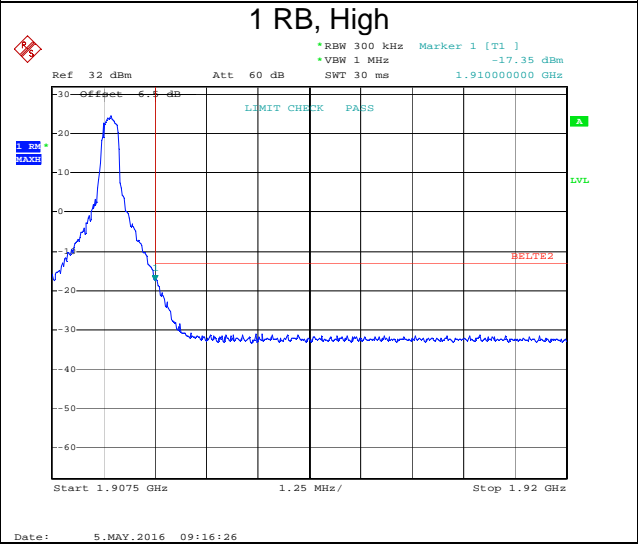
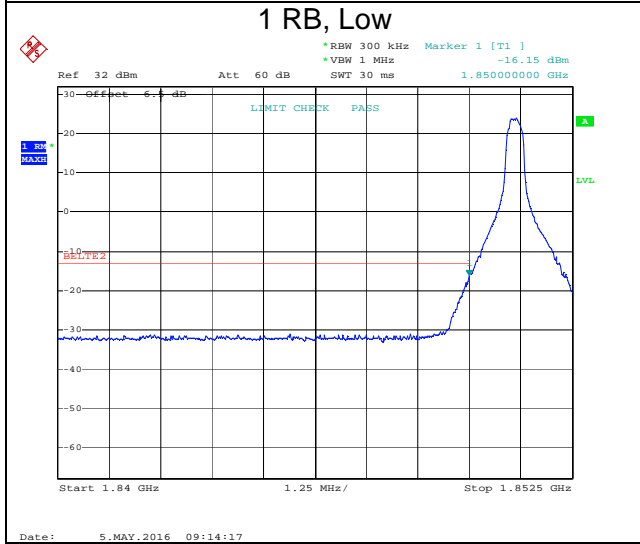
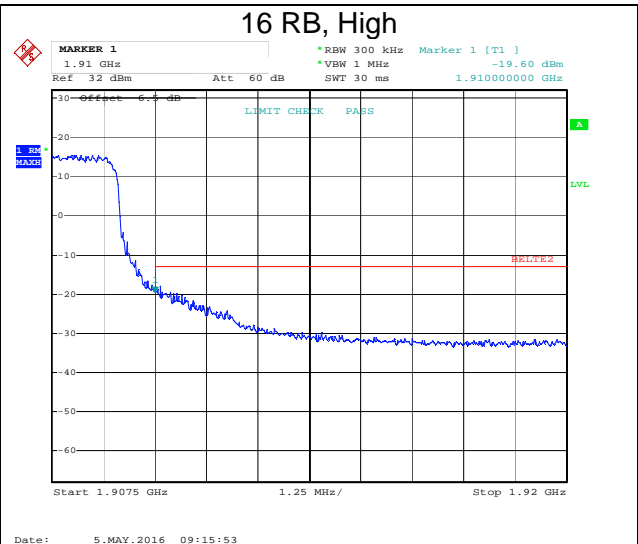
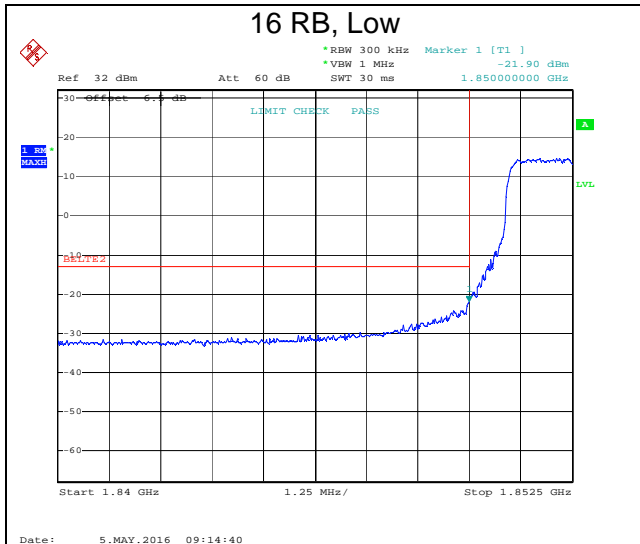

Band 4, 5 MHz BW, QPSK

Channel 19975, 1712.5 MHz Below 1710 MHz	Channel 20375, 1752.5 MHz Above 1755 MHz
---	---

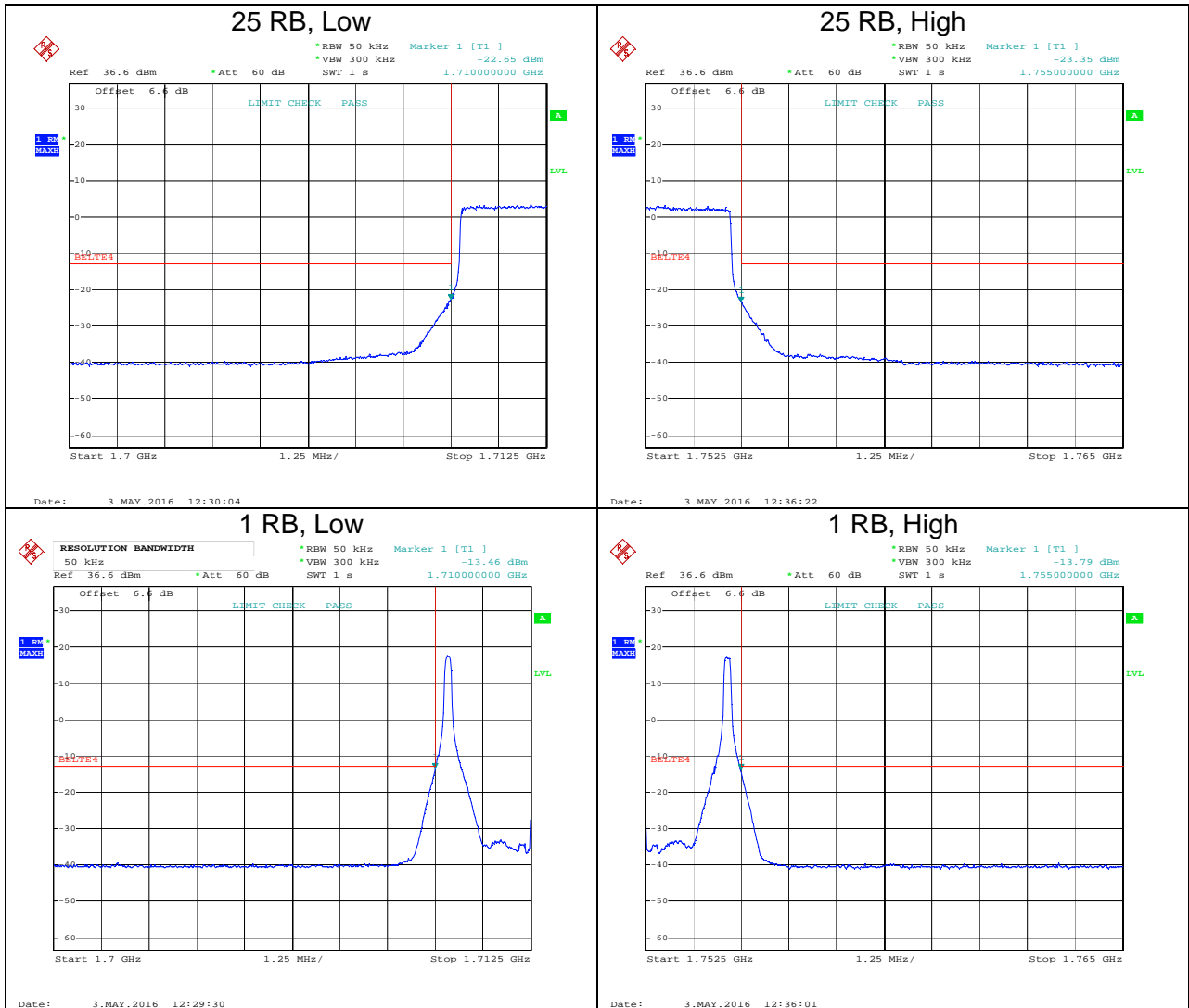

Band 4, 5 MHz BW, 16-QAM

Channel 19975, 1712.5 MHz Below 1710 MHz	Channel 20375, 1752.5 MHz Above 1755 MHz
---	---

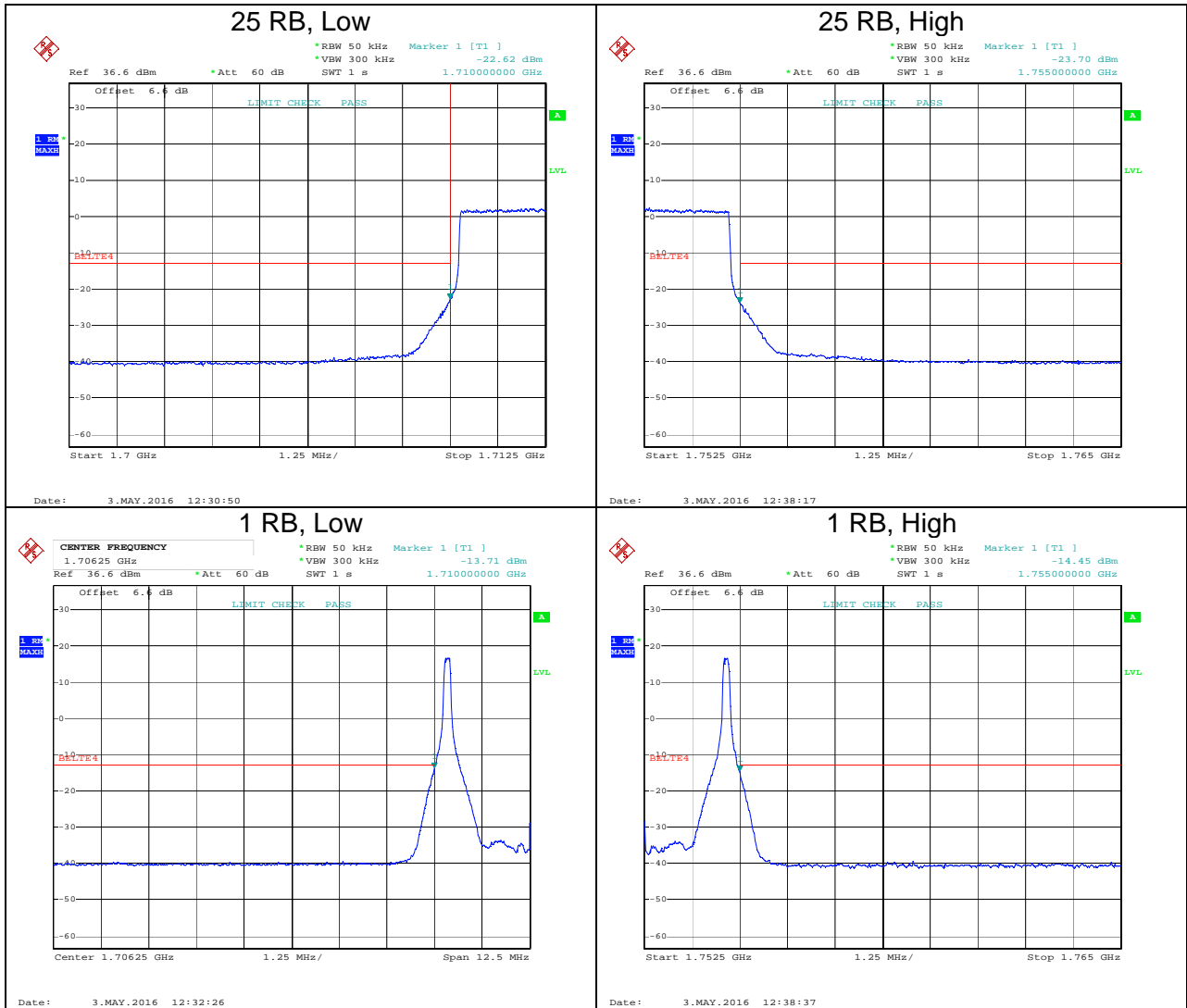

Band 4, 10 MHz BW, QPSK

Channel 20000, 1715.0 MHz Below 1710 MHz	Channel 20350, 1750.0 MHz Above 1755 MHz
---	---

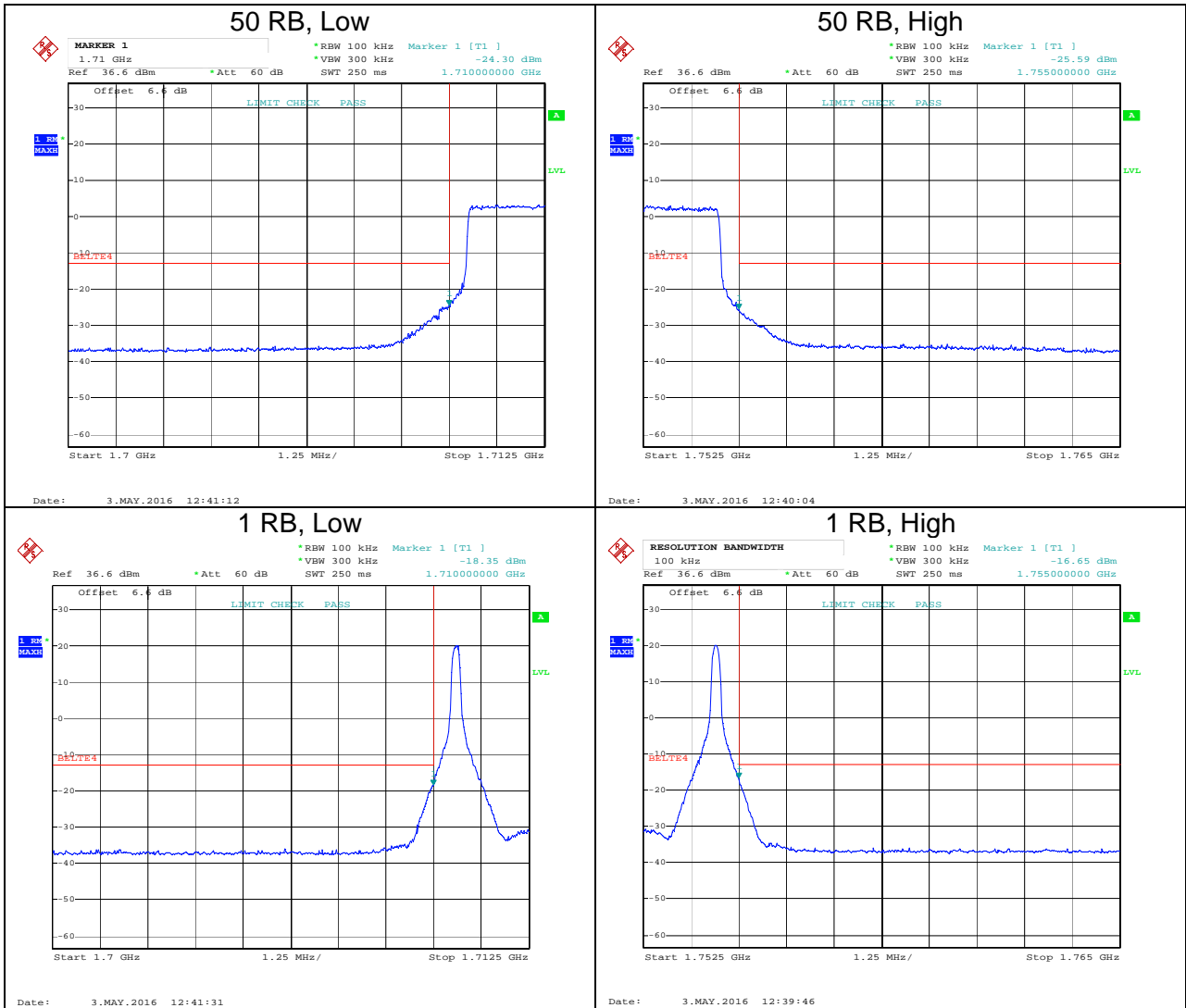

Band 4, 10 MHz BW, 16-QAM

Channel 20000, 1715.0 MHz Below 1710 MHz	Channel 20350, 1750.0 MHz Above 1755 MHz
---	---

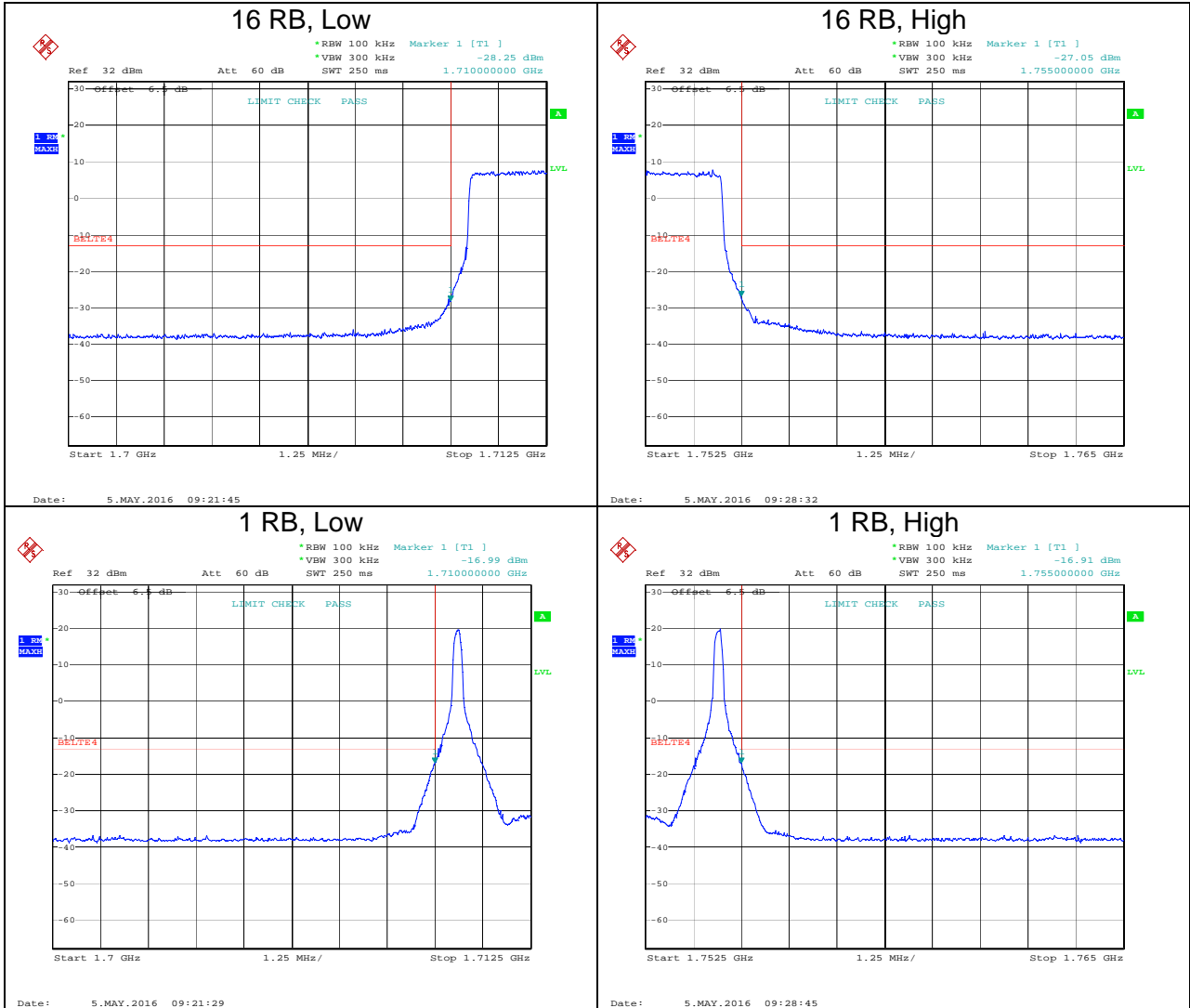

Band 4, 15 MHz BW, QPSK

Channel 20025, 1717.5 MHz Below 1710 MHz	Channel 20325, 1747.5 MHz Above 1755 MHz
---	---

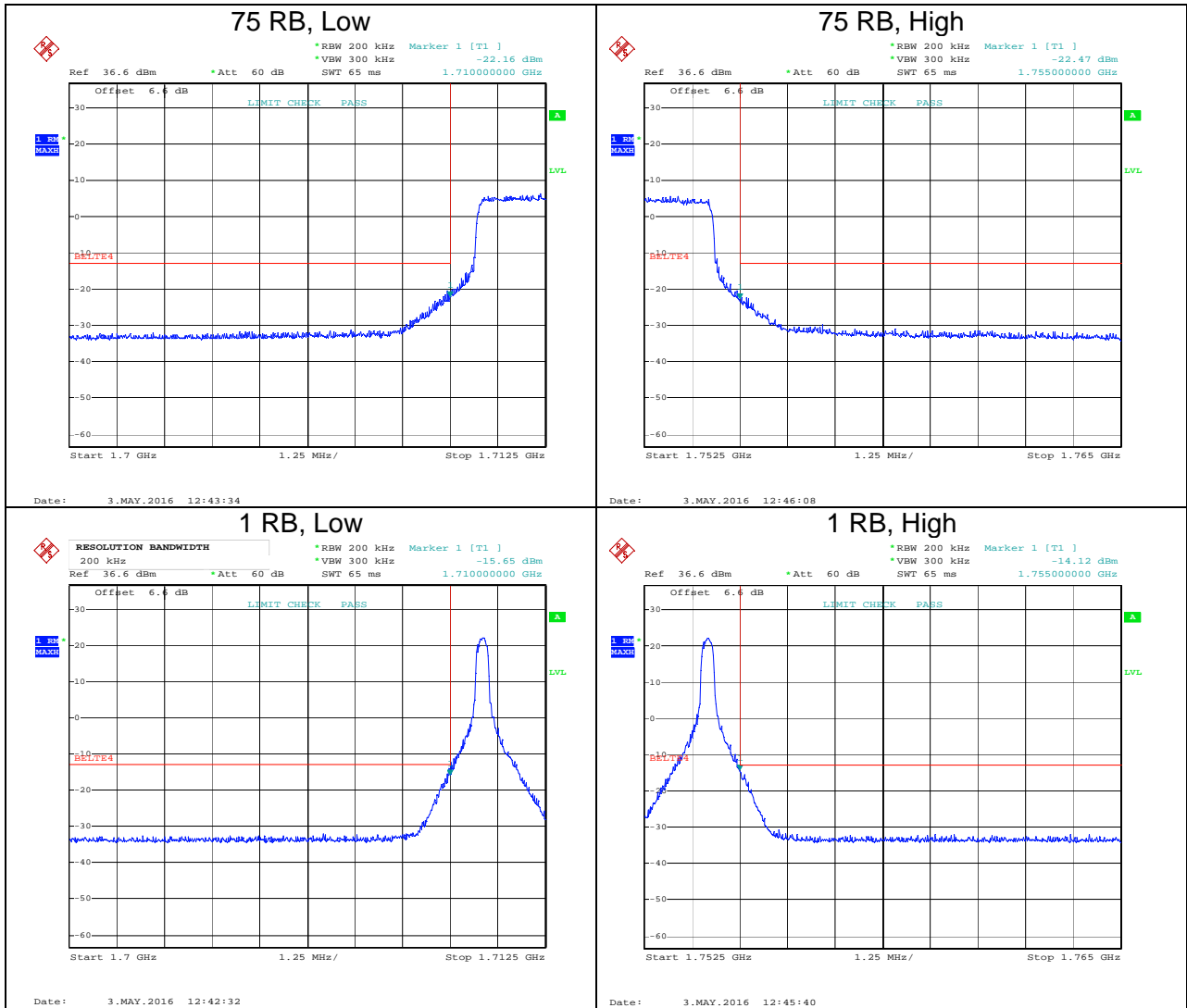

Band 4, 15 MHz BW, 16-QAM

Channel 20025, 1717.5 MHz
Below 1710 MHz

Channel 20325, 1747.5 MHz
Above 1755 MHz

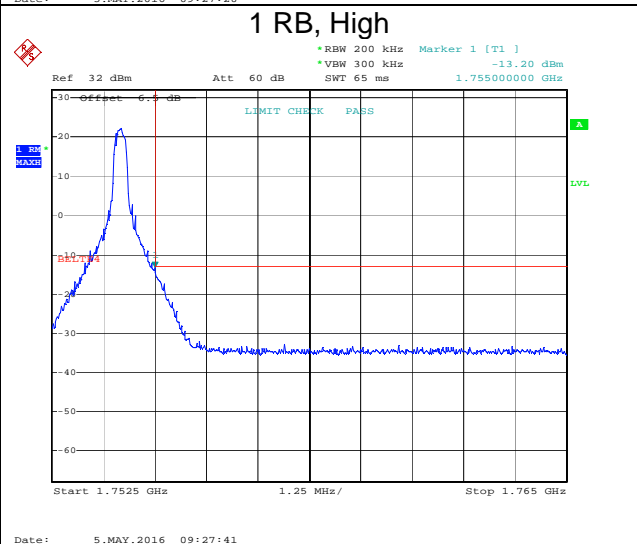
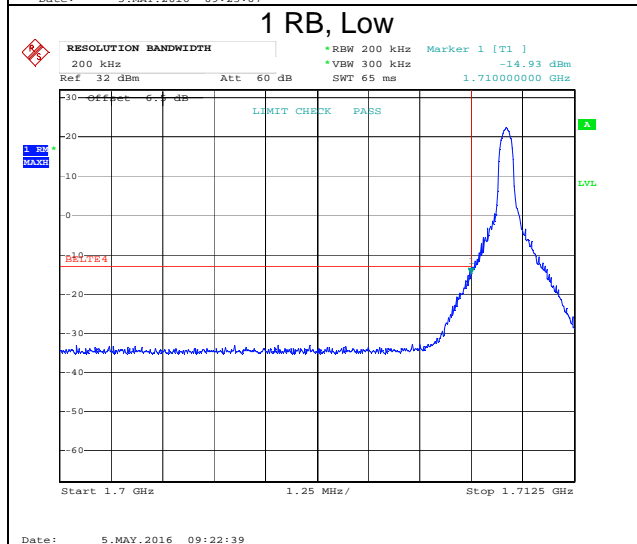
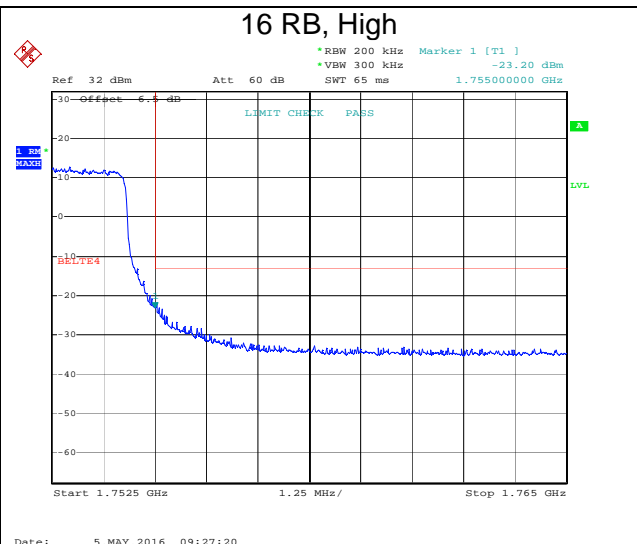
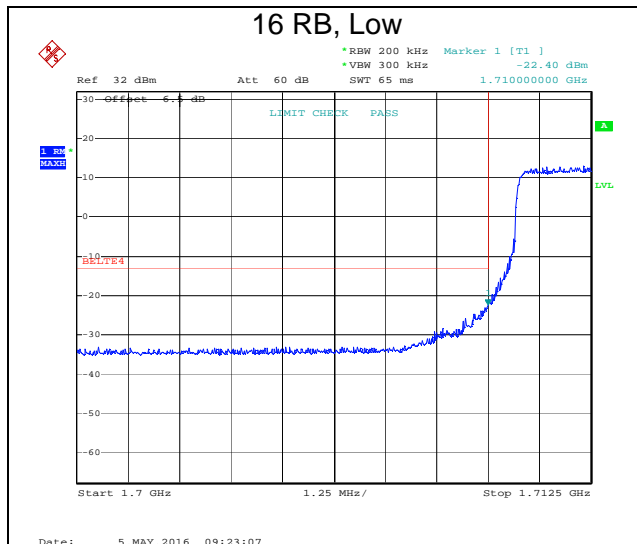

Band 4, 20 MHz BW, QPSK

Channel 20050, 1720.0 MHz Below 1710 MHz	Channel 20300, 1745.0 MHz Above 1755 MHz
---	---

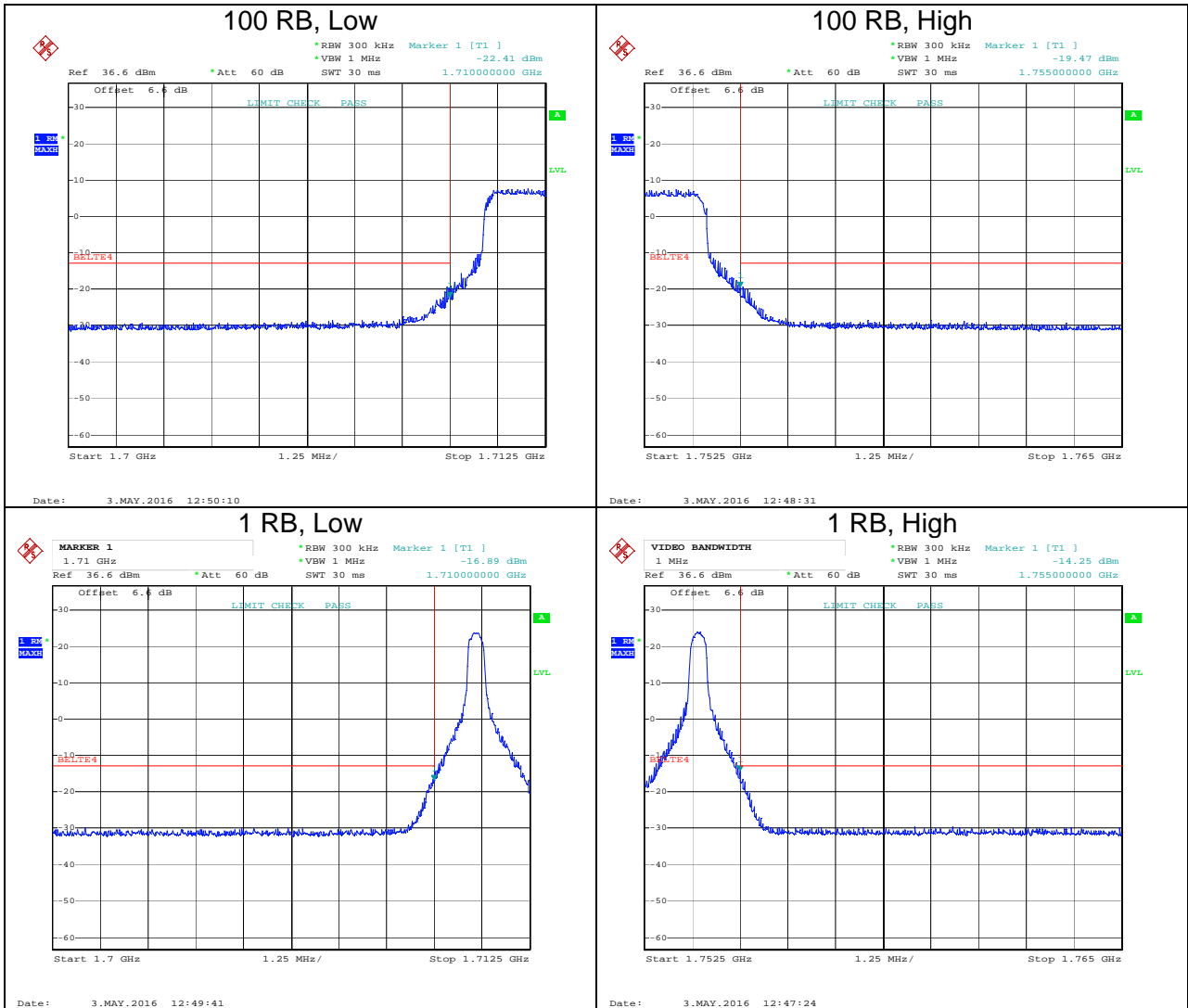

Band 4, 20 MHz BW, 16-QAM

Channel 20050, 1720.0 MHz
Below 1710 MHz

Channel 20300, 1745.0 MHz
Above 1755 MHz

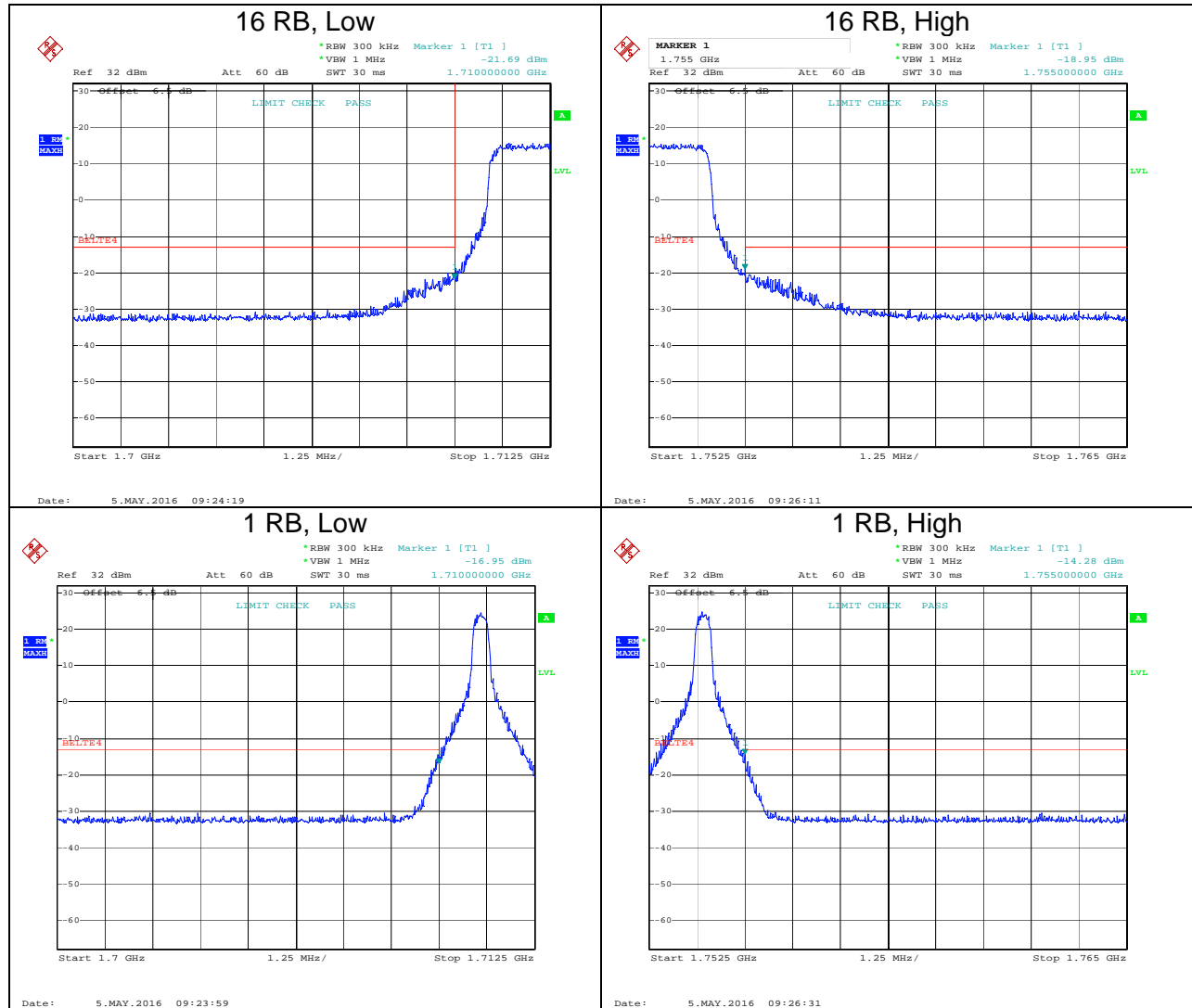

Band 12, 5 MHz BW, QPSK

Channel 23025, 700.5 MHz Below 698 MHz	Channel 23155, 713.5 MHz Above 716 MHz
---	---

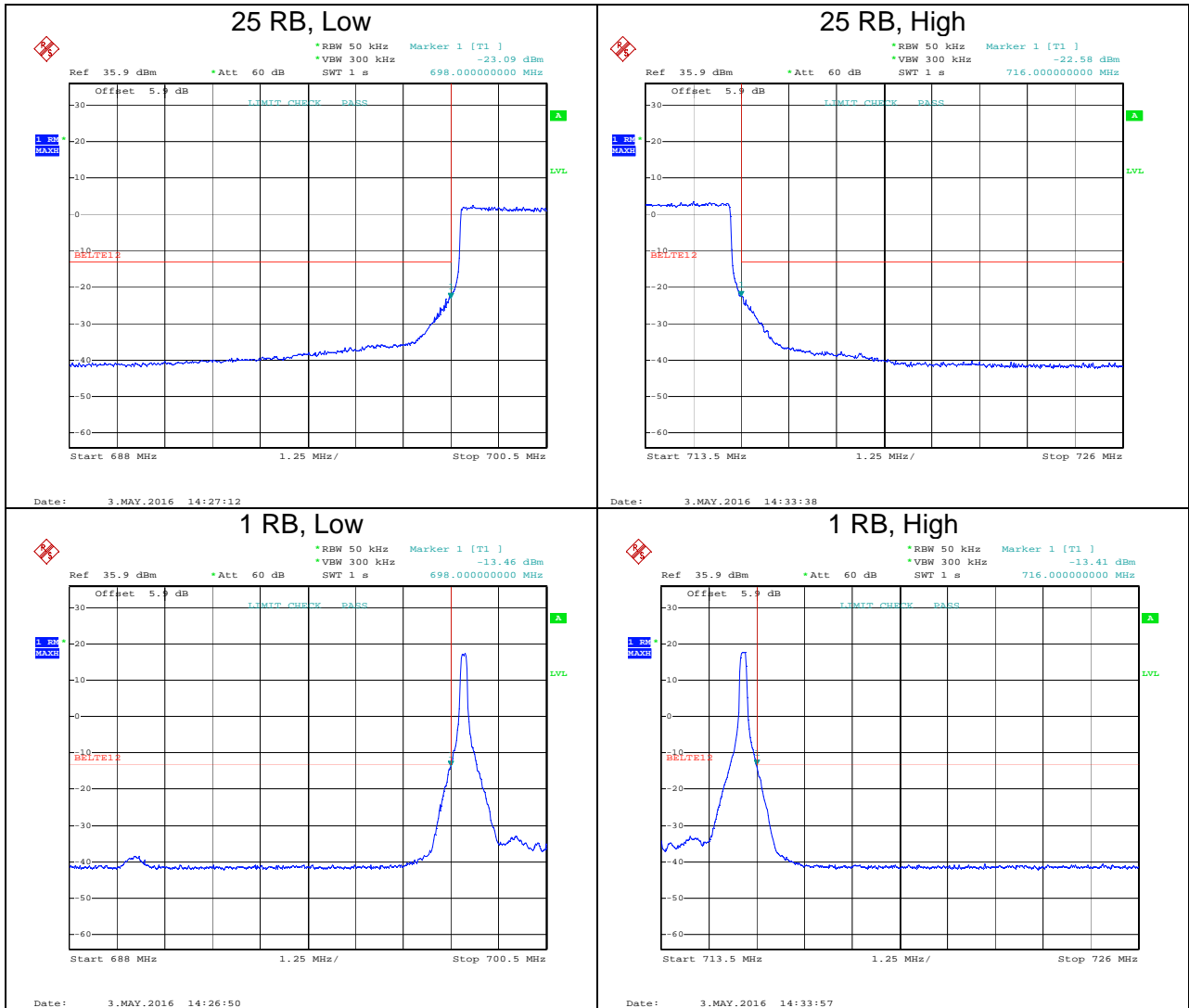

Band 12, 5 MHz BW, 16-QAM

Channel 23025, 700.5 MHz Below 698 MHz	Channel 23155, 713.5 MHz Above 716 MHz
---	---

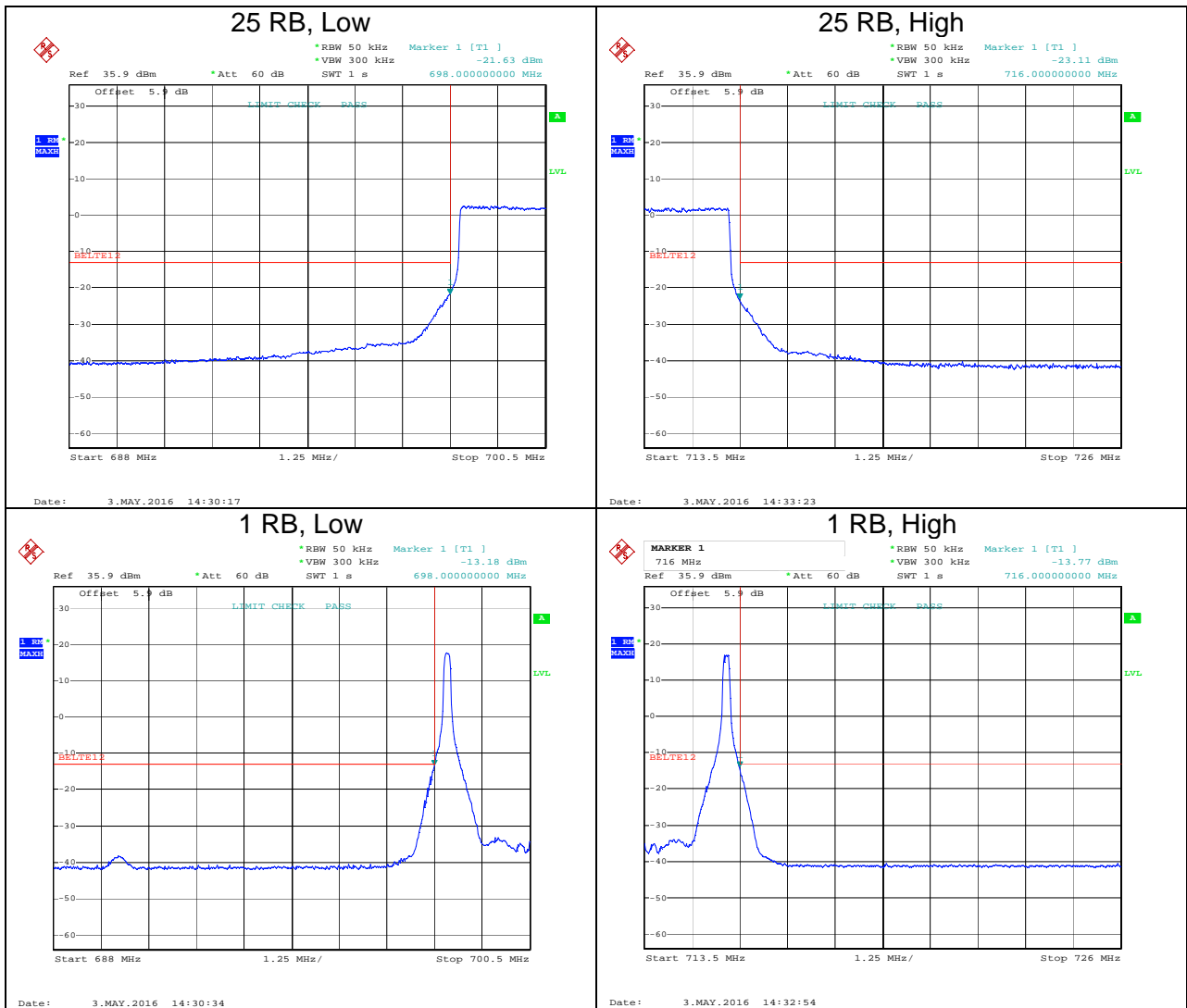

Band 12, 10 MHz BW, QPSK

Channel 23050, 703.0 MHz Below 698 MHz	Channel 23130, 711.0 MHz Above 716 MHz
---	---

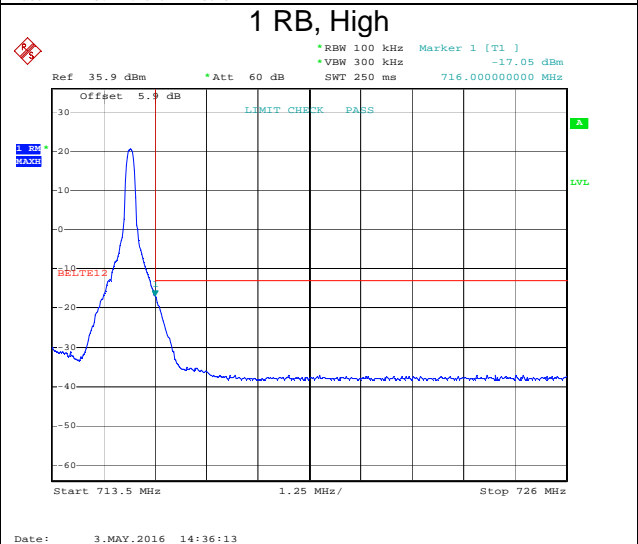
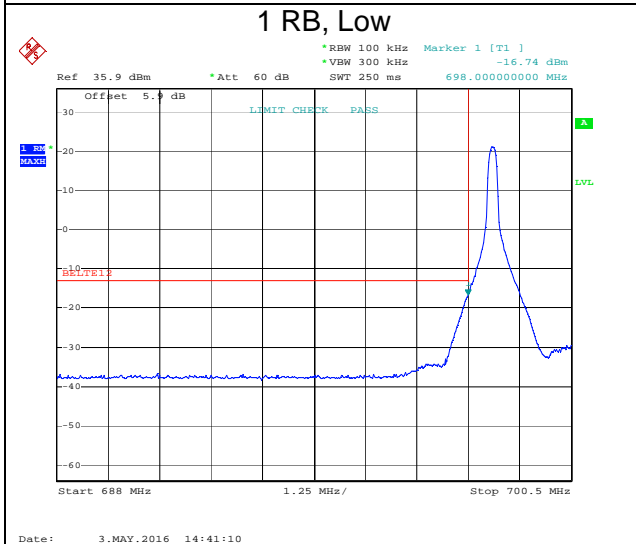
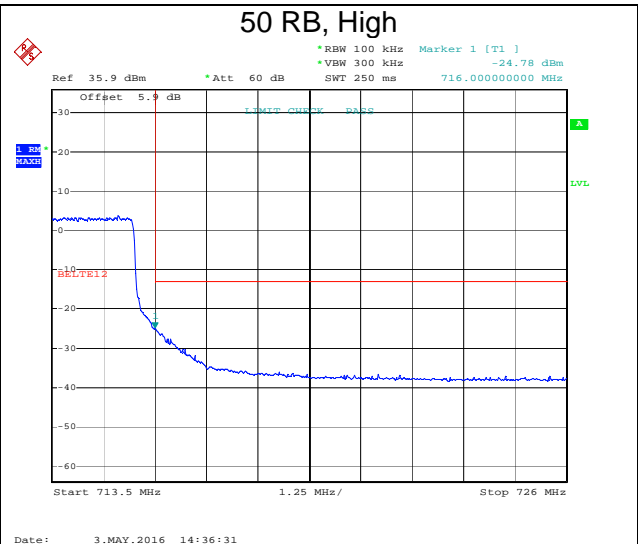
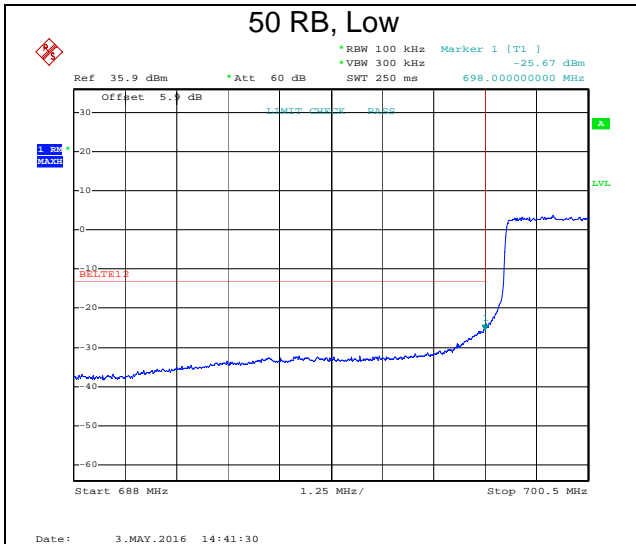

Band 12, 10 MHz BW, 16-QAM

Channel 23050, 703.0 MHz Below 698 MHz	Channel 23130, 711.0 MHz Above 716 MHz
---	---

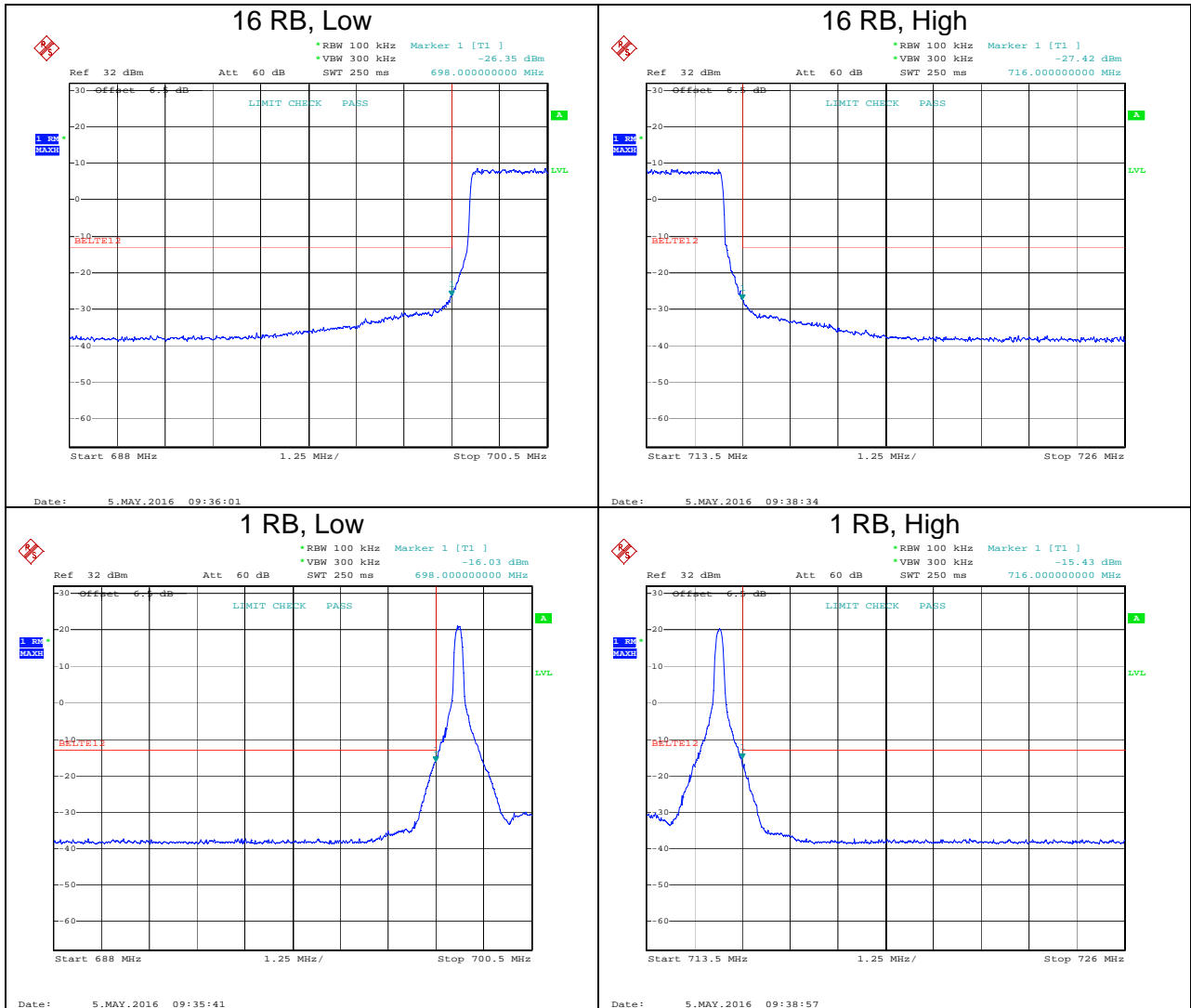

7 Radiated Output Power

7.1 Test Limits

§ 24.232

(c) Mobile and portable stations are limited to 2 watts EIRP and the equipment must employ a means for limiting power to the minimum necessary for successful communications.

§ 27.50

(c) (10) Portable stations (hand-held devices) in the 600 MHz uplink band and the 698-746 MHz band, and fixed and mobile stations in the 600 MHz uplink band are limited to 3 watts ERP.

§ 27.50

(d) (4) Fixed, mobile, and portable (hand-held) stations operating in the 1710-1755 MHz band and mobile and portable stations operating in the 1695-1710 MHz and 1755-1780 MHz bands are limited to 1 watt EIRP. Fixed stations operating in the 1710-1755 MHz band are limited to a maximum antenna height of 10 meters above ground. Mobile and portable stations operating in these bands must employ a means for limiting power to the minimum necessary for successful communications.

7.2 Test Procedure

The radiated output power was determined by adding the peak antenna gain to the highest measured conducted output power to determine the maximum radiated power. The peak antenna gain was calculated by taking into account the ERP / EIRP limits as well as the Maximum Permissible Exposure (MPE) limits at 20cm.

$$ERP = ConductedOutputPower(dBm) + AntennaGain(dBi) - 2.15$$

$$EIRP = ConductedOutputPower(dBm) + AntennaGain(dBi)$$

7.3 Results:

The US130Q LTE E-UTRA meets the radiated power requirements of FCC §24.232 and §27.50. The ERP / EIRP results as well as the MPE calculations are used to determine the maximum allowable gain for each frequency band.

Radiated Output Power (QPSK)				
Band	Conducted Power (dBm)	Max Antenna Gain (dBi)	EIRP (dBm)	ERP(dBm)
Band 2	23.28	8.00	31.28	29.13
Band 4	23.38	5.00	28.38	26.23
Band 12	23.29	11.92	35.21	33.06

Radiated Output Power (16QAM)				
Band	Conducted Power (dBm)	Max Antenna Gain (dBi)	EIRP (dBm)	ERP(dBm)
Band 2	22.68	8.00	30.68	28.53
Band 4	22.45	5.00	27.45	25.30
Band 12	23.08	11.92	35.00	32.85

Max Antenna Gain Calculations

Band 2 (part 24.232, c)			
Frequency	1880 MHz		
MPE Limit	1.000 mW/cm²		
Distance	20 cm		
Maximum Scaled Power	25 dBm		
TX Ant Gain	8 dBi		
EIRP	33		1995.262 mW
Power Density	0.3969 mW/cm² at 20cm		
EIRP Limit	2000mW		

Band 4 (part 27.50, d, 4)			
Frequency	1732.5 MHz		
MPE Limit	1.000 mW/cm²		
Distance	20 cm		
Maximum Scaled Power	25 dBm		
TX Ant Gain	5 dBi		
EIRP	30		1000 mW
Power Density	0.1989 mW/cm² at 20cm		
EIRP Limit	1000mW		

Band 12 (part 27.50, c, 10)			
Frequency	707.5 MHz		
MPE Limit	0.472 mW/cm²		
Distance	20 cm		
Maximum Scaled Power	25 dBm		
TX Ant Gain	11.92 dBi		
EIRP	36.92		4920.395 mW
ERP	34.77		2999.163 mW
Power Density	0.9789 mW/cm² at 20cm		
ERP Limit	3000mW		

8 Radiated Spurious Emissions (Transmitter)

8.1 Test Limits

§ 2.1051

The radio frequency voltage or powers generated within the equipment and appearing on a spurious frequency shall be checked at the equipment output terminals when properly loaded with a suitable artificial antenna. Curves or equivalent data shall show the magnitude of each harmonic and other spurious emission that can be detected when the equipment is operated under the conditions specified in §2.1049 as appropriate. The magnitude of spurious emissions which are attenuated more than 20 dB below the permissible value need not be specified.

§ 24.238

- (a) Out of band emissions. The power of any emission outside of the authorized operating frequency ranges must be attenuated below the transmitting power (P) by a factor of at least $43 + 10 \log(P)$ dB.
- (b) Measurement procedure. Compliance with these rules is based on the use of measurement instrumentation employing a resolution bandwidth of 1 MHz or greater. However, in the 1 MHz bands immediately outside and adjacent to the frequency block a resolution bandwidth of at least one percent of the emission bandwidth of the fundamental emission of the transmitter may be employed. A narrower resolution bandwidth is permitted in all cases to improve measurement accuracy provided the measured power is integrated over the full required measurement bandwidth (i.e. 1 MHz or 1 percent of emission bandwidth, as specified). The emission bandwidth is defined as the width of the signal between two points, one below the carrier center frequency and one above the carrier center frequency, outside of which all emissions are attenuated at least 26 dB below the transmitter power.

§ 27.53

- (g) For operations in the 600 MHz band and the 698-746 MHz band, the power of any emission outside a licensee's frequency band(s) of operation shall be attenuated below the transmitter power (P) within the licensed band(s) of operation, measured in watts, by at least $43 + 10 \log(P)$ dB. Compliance with this provision is based on the use of measurement instrumentation employing a resolution bandwidth of 100 kilohertz or greater. However, in the 100 kilohertz bands immediately outside and adjacent to a licensee's frequency block, a resolution bandwidth of at least 30 kHz may be employed.
- (h) *AWS emission limits*—(1) *General protection levels*. Except as otherwise specified below, for operations in the 1695-1710 MHz, 1710-1755 MHz, 1755-1780 MHz, 1915-1920 MHz, 1995-2000 MHz, 2000-2020 MHz, 2110-2155 MHz, 2155-2180 MHz, and 2180-2200 bands, the power of any emission outside a licensee's frequency block shall be attenuated below the transmitter power (P) in watts by at least $43 + 10 \log_{10}(P)$ dB.

8.2 Test Procedure

The EUT was placed on a non-conductive turntable. The measurement antenna was placed at a distance of 3 meters from the EUT. The EUT was forced to transmit at its maximum output power setting. During the tests, the antenna height and EUT azimuth were varied in order to identify the maximum level of emissions from the EUT.

The frequency range up to tenth harmonic was investigated in order to identify the spurious emission. Once the spurious emissions were identified, the power of the emission was determined using the substitution method described in TIA-603-C. The spurious emissions attenuation was calculated as the difference between radiated power at the fundamental frequency and at the spurious emissions frequency.

8.3 Test Equipment Used:

Description	Serial Number	Manufacturer	Model	Cal. Date	Cal. Due
EMI Test Receiver	1302.6005.40	Rohde&Schwarz	ESU40	9/20/2015	9/20/2016
Preamplifier	122005	Rohde&Schwarz	TS-PR18	11/19/2015	11/19/2016
Horn Antenna	00156319	ETS	3117	5/15/2015	5/15/2016
Horn Antenna	00154521	ETS	3117	11/3/2015	11/3/2016
Bilog Antenna	2362	ETS	3142B	1/16/2015	1/16/2016
Bilog Antenna	00051864	ETS	3142C	1/20/2015	1/20/2016
System Controller	121701-1	Sunol Sciences	SC99V	Time of Use	Time of Use
High Pass Filter	1	Wainwright	WHKX12-2533.85-2710-18000-40SS	Time of Use	Time of Use
High Pass Filter	25	Wainwright	WHKX12-1028.5-1100-1500-40SS	Time of Use	Time of Use
Base Station Simulator	3917	Rohde & Schwarz	CMW500	9/19/2015	9/19/2016
Signal Generator	3915	Rohde&Schwarz	SMB100A	9/18/2015	9/18/2016

8.4 Results:

All radiated spurious emissions were attenuated below the transmitting power (P) by a factor of at least 43 + 10 log(P) dB which is equivalent to -13dBm. The emissions were measured using an RMS detector and the analyzer was gated so that the emission was only measured during the on-times of the transmitter.

Band 2

Radiated Spurious Emissions Measurement								
Test Engineer:	Brian Daffin		Start Date:	5/5/2016		End Date:	5/11/2016	
Temperature:	26.5C		Humidity:	41.70%		Pressure:	985.4mbar	
RBW:	1MHz		VBW:	3MHz				
Notes: Results represent the worst case from 3 orthogonal axis positions.								
			A	B	C	D	E	F
Band/Channel	Spurious Frequency (MHz)	Polarity	Device Reading (dBm)	Signal Generator Level (dBm)	Cable Loss (dB)	Tx Antenna Gain (dBd)	Limit (dBm)	Radiated Spurious Emission Level (dBm)
Band 2 Low Ch (1852.5 MHz)	3705.0	H	-70.66	-59.18	4.85	8.26	-13	-55.77
	3705.0	V	-68.14	-56.52	4.85	8.26	-13	-53.11
	5557.5	H	-64.96	-48.03	6.91	10.40	-13	-44.55
	5557.5	V	-61.04	-46.12	6.91	10.40	-13	-42.64
	7410.0	H	-71.27	-52.37	7.75	11.84	-13	-48.28
	7410.0	V	-69.37	-51.34	7.75	11.84	-13	-47.25
	9262.5	H	-70.42	-49.9	9.08	13.19	-13	-45.79
	9262.5	V	-69.68	-49.88	9.08	13.19	-13	-45.77
	11115.0	H	-70.67	-45.41	10.47	13.23	-13	-42.65
11115.0	V	-70.92	-46.66	10.47	13.23	-13	-43.90	
Band 2 Mid Ch (1880.0 MHz)	3760.0	H	-69.83	-58.32	5.20	8.26	-13	-55.26
	3760.0	V	-69.87	-58.14	5.20	8.26	-13	-55.08
	5640.0	H	-68.07	-46.43	7.09	10.56	-13	-42.96
	5640.0	V	-61.03	-46.78	7.09	10.56	-13	-43.31
	7520.0	H	-70.48	-51.35	8.01	11.93	-13	-47.44
	7520.0	V	-67.32	-48.79	8.01	11.93	-13	-44.88
	9400.0	H	-71.08	-50.22	9.15	13.12	-13	-46.26
	9400.0	V	-71.18	-50.47	9.15	13.12	-13	-46.51
	11280.0	H	-70.47	-44.67	10.16	13.26	-13	-41.57
11280.0	V	-71.7	-46.09	10.16	13.26	-13	-42.99	
Band 2 High Ch (1907.5 MHz)	3815.0	H	-68.63	-56.67	5.00	8.25	-13	-53.42
	3815.0	V	-67.4	-55.18	5.00	8.25	-13	-51.93
	5722.5	H	-65.24	-48.08	6.61	10.66	-13	-44.03
	5722.5	V	-60.48	-45.66	6.61	10.66	-13	-41.61
	7630.0	H	-70.09	-51.64	8.15	11.98	-13	-47.81
	7630.0	V	-65.59	-47.75	8.15	11.98	-13	-43.92
	9537.5	H	-71.51	-50.17	8.41	13.09	-13	-45.50
	9537.5	V	-71.41	-50.96	8.41	13.09	-13	-46.29
	11445.0	H	-71.47	-45.14	9.13	13.25	-13	-41.02
11445.0	V	-71.75	-46.22	9.13	13.25	-13	-42.10	
								F=B-C+D

Band 4

Radiated Spurious Emissions Measurement								
Test Engineer:	Brian Daffin	Start Date:	5/5/2016		End Date:	5/11/2016		
Temperature:	26.5C	Humidity:	41.70%		Pressure:	985.4mbar		
RBW:	1MHz	VBW:	3MHz					
Notes:	Results represent the worst case from 3 orthogonal axis positions.							
			A	B	C	D	E	F
Band/Channel	Spurious Frequency (MHz)	Polarity	Device Reading (dBm)	Signal Generator Level (dBm)	Cable Loss (dB)	Tx Antenna Gain (dBd)	Limit (dBm)	Radiated Spurious Emission Level (dBm)
Band 4 Low Ch (1712.5MHz)	3425.0	H	-58.99	-48.85	4.60	7.83	-13	-45.62
	3425.0	V	-53.31	-41.88	4.60	7.83	-13	-38.65
	5137.5	H	-58.56	-43.42	6.06	10.12	-13	-39.36
	5137.5	V	-54.14	-39.47	6.06	10.12	-13	-35.41
	6850.0	H	-68.45	-50.13	7.59	11.11	-13	-46.61
	6850.0	V	-68.93	-51.29	7.59	11.11	-13	-47.77
	8562.5	H	-69.93	-50.40	8.76	12.91	-13	-46.25
	8562.5	V	-68.99	-50.25	8.76	12.91	-13	-46.10
	10275.0	H	-69.80	-46.32	9.89	13.06	-13	-43.16
10275.0	V	-69.08	-46.45	9.89	13.06	-13	-43.29	
Band 4 Mid Ch (1732.5MHz)	3465.0	H	-61.52	-51.13	4.80	7.83	-13	-48.10
	3465.0	V	-58.18	-46.74	4.80	7.83	-13	-43.71
	5197.5	H	-58.68	-43.89	6.18	10.12	-13	-39.95
	5197.5	V	-56.05	-41.85	6.18	10.12	-13	-37.91
	6930.0	H	-68.22	-50.70	7.60	11.26	-13	-47.04
	6930.0	V	-66.60	-49.86	7.60	11.26	-13	-46.20
	8662.5	H	-69.33	-49.43	8.79	12.98	-13	-45.24
	8662.5	V	-69.98	-51.19	8.79	12.98	-13	-47.00
10395.0	H	-69.73	-45.12	11.05	13.08	-13	-43.09	
10395.0	V	-69.87	-46.45	11.05	13.08	-13	-44.42	
Band 4 High Ch (1752.5MHz)	3505.0	H	-63.14	-52.33	4.56	8.15	-13	-48.74
	3505.0	V	-60.64	-48.99	4.56	8.15	-13	-45.40
	5257.5	H	-62.63	-47.37	6.27	10.27	-13	-43.37
	5257.5	V	-58.14	-43.29	6.27	10.27	-13	-39.29
	7010.0	H	-62.29	-44.12	7.73	11.36	-13	-40.49
	7010.0	V	-57.25	-38.15	7.73	11.36	-13	-34.52
	8762.5	H	-64.38	-43.91	8.50	12.92	-13	-39.49
	8762.5	V	-58.08	-38.28	8.50	12.92	-13	-33.86
	10515.0	H	-68.16	-44.11	9.30	13.08	-13	-40.33
10515.0	V	-68.34	-45.80	9.30	13.08	-13	-42.02	
								F=B-C+D

Band 12

Radiated Spurious Emissions Measurement								
Test Engineer:	Brian Daffin		Start Date:	5/5/2016		End Date:	5/11/2016	
Temperature:	26.5C		Humidity:	41.70%		Pressure:	985.4mbar	
RBW:	1MHz		VBW:	3MHz				
Notes:	Results represent the worst case from 3 orthogonal axis positions.							
			A	B	C	D	E	F
Band/Channel	Spurious Frequency (MHz)	Polarity	Device Reading (dBm)	Signal Generator Level (dBm)	Cable Loss (dB)	Tx Antenna Gain (dBd)	Limit (dBm)	Radiated Spurious Emission Level (dBm)
Band 12 Low Ch (701.5MHz)	1401.0	H	-59.33	-52.67	3.06	4.28	-13	-51.45
	1401.0	V	-52.77	-43.82	3.06	4.28	-13	-42.60
	2101.5	H	-58.59	-50.51	3.65	4.89	-13	-49.27
	2101.5	V	-53.10	-43.11	3.65	4.89	-13	-41.87
	2802.0	H	-68.33	-59.75	4.16	6.89	-13	-57.02
	2802.0	V	-68.02	-58.31	4.16	6.89	-13	-55.58
	3502.5	H	-67.54	-57.78	4.56	8.15	-13	-54.19
	3502.5	V	-60.66	-49.69	4.56	8.15	-13	-46.10
	4203.0	H	-66.42	-54.66	4.98	9.01	-13	-50.63
4203.0	V	-66.23	-54.18	4.98	9.01	-13	-50.15	
Band 12 Mid Ch (707.5MHz)	1415.0	H	-59.93	-53.71	2.80	4.28	-13	-52.23
	1415.0	V	-54.67	-46.42	2.80	4.28	-13	-44.94
	2122.5	H	-48.46	-40.54	3.69	4.89	-13	-39.34
	2122.5	V	-42.75	-33.04	3.69	4.89	-13	-31.84
	2830.0	H	-67.87	-59.60	4.21	6.89	-13	-56.92
	2830.0	V	-68.55	-58.79	4.21	6.89	-13	-56.11
	3537.5	H	-68.30	-58.37	4.60	8.15	-13	-54.82
	3537.5	V	-69.21	-58.46	4.60	8.15	-13	-54.91
	4245.0	H	-66.80	-55.12	5.00	9.01	-13	-51.11
4245.0	V	-67.55	-55.20	5.00	9.01	-13	-51.19	
Band 12 High Ch (713.5MHz)	1427.0	H	-55.66	-49.33	2.80	4.28	-13	-47.85
	1427.0	V	-50.95	-42.67	2.80	4.28	-13	-41.19
	2140.5	H	-61.80	-53.89	3.71	4.89	-13	-52.71
	2140.5	V	-58.21	-48.38	3.71	4.89	-13	-47.20
	2854.0	H	-68.29	-59.83	4.26	6.89	-13	-57.20
	2854.0	V	-66.45	-56.22	4.26	6.89	-13	-53.59
	3567.5	H	-64.75	-54.59	4.73	8.15	-13	-51.17
	3567.5	V	-59.25	-48.30	4.73	8.15	-13	-44.88
	4281.0	H	-67.92	-56.19	5.33	9.01	-13	-52.51
4281.0	V	-63.38	-51.06	5.33	9.01	-13	-47.38	
								F=B-C+D

9 Frequency Stability

9.1 Test Limits

§ 2.1055, §24.235, §27.54

The frequency stability of the transmitter was required to maintain a ± 2.5 ppm tolerance.

9.2 Test Procedure

The equipment under test was connected to a DC power source and the RF output was connected to a Base Station Simulator. The Base Station Simulator was set to force the EUT to its maximum power setting. The EUT was placed inside the temperature chamber. The DC leads and RF output cable exited the chamber through an opening made for that purpose. After the temperature stabilized for approximately 30 minutes, the frequency error was read from the base station simulator. At 20C the input voltage was varied from 85% to 115% and the frequency stability vs input voltage was recorded.

9.3 Test Equipment Used:

Description	Serial Number	Manufacturer	Model	Cal. Date	Cal. Due
Base Station Simulator	3917	Rohde & Schwarz	CMW500	9/19/2015	9/19/2016
Environmental Chamber	32692	Thermotron	SM-8C	4/25/2016	4/25/2017
Multimeter	3550	Fluke	115	8/4/2015	8/4/2016
Power Supply	3513	Gwinstek	GPS1850	NCR	NCR

9.4 Results:

The tables below show the frequency stability data. In all cases the test sample met the ± 2.5 ppm limit.

Band 2

Operating Frequency:	1,880,000,000 Hz			
Channel:	18900			
Reference Voltage:	3.3 VDC			
Deviation Limit:	2.5 ppm			
Notes:	Frequency Stability in Band 2			

Voltage (%)	Voltage (DC)	Temp (°C)	Frequency Error (Hz)	Deviation (%)	Deviation (ppm)
100%	3.3	-30	2.1	0.0000003	0.0030
100%	3.3	-20	1.8	0.0000003	0.0025
100%	3.3	-10	2.1	0.0000003	0.0030
100%	3.3	0	0.9	0.0000001	0.0013
100%	3.3	10	2.2	0.0000003	0.0031
100%	3.3	20	3.1	0.0000004	0.0044
100%	3.3	30	3.6	0.0000005	0.0051
100%	3.3	40	5.1	0.0000007	0.0072
100%	3.3	50	1.1	0.0000002	0.0016
100%	3.3	60	-0.4	-0.0000001	-0.0006
115%	3.8	20	3.4	0.0000005	0.0048
85%	2.8	20	4.2	0.0000006	0.0059

Band 4

Operating Frequency:		1,732,500,000	Hz		
Channel:		20175			
Reference Voltage:		3.3	VDC		
Deviation Limit:		2.5	ppm		
Notes:		Frequency Stability in Band 4			
Voltage (%)	Voltage (DC)	Temp (°C)	Frequency Error (Hz)	Deviation (%)	Deviation (ppm)
100%	3.3	-30	1.2	0.0000001	0.0014
100%	3.3	-20	2.7	0.0000003	0.0032
100%	3.3	-10	0.4	0.0000000	0.0005
100%	3.3	0	2.3	0.0000003	0.0027
100%	3.3	10	1.9	0.0000002	0.0023
100%	3.3	20	0.8	0.0000001	0.0010
100%	3.3	30	0.6	0.0000001	0.0007
100%	3.3	40	3.7	0.0000004	0.0044
100%	3.3	50	3.1	0.0000004	0.0037
100%	3.3	60	2.5	0.0000003	0.0030
115%	3.8	20	1.6	0.0000002	0.0019
85%	2.8	20	2.1	0.0000003	0.0025

Band 12

Operating Frequency:		707,500,000	Hz		
Channel:		23095			
Reference Voltage:		3.3	VDC		
Deviation Limit:		2.5	ppm		
Notes:		Frequency Stability in Band 12			
Voltage (%)	Voltage (DC)	Temp (°C)	Frequency Error (Hz)	Deviation (%)	Deviation (ppm)
100%	3.3	-30	0.9	0.0000001	0.0013
100%	3.3	-20	0.8	0.0000001	0.0011
100%	3.3	-10	0.9	0.0000001	0.0013
100%	3.3	0	2.2	0.0000003	0.0031
100%	3.3	10	0.2	0.0000000	0.0003
100%	3.3	20	-1.2	-0.0000002	-0.0017
100%	3.3	30	-0.6	-0.0000001	-0.0008
100%	3.3	40	0.2	0.0000000	0.0003
100%	3.3	50	0.3	0.0000000	0.0004
100%	3.3	60	-0.5	-0.0000001	-0.0007
115%	3.8	20	-1.1	-0.0000002	-0.0016
85%	2.8	20	1.8	0.0000003	0.0025

10 Measurement Uncertainty

The measured value related to the corresponding limit will be used to decide whether the equipment meets the requirements.

The measurement uncertainty figures were calculated and correspond to a coverage factor of $k = 2$, providing a confidence level of respectively 95.45 % in the case where the distributions characterizing the actual measurement uncertainties are normal (Gaussian).

Measurement uncertainty Table

Parameter	Uncertainty	Notes
Radiated emissions, 30 to 1000 MHz	+3.9dB	
Radiated emissions, 1 to 18 GHz	+4.2dB	
Radiated emissions, 18 to 40 GHz	+4.3dB	
Power Port Conducted emissions, 150kHz to 30 MHz	+2.8dB	

11 Revision History

Revision Level	Date	Report Number	Notes
0	5/31/2016	102594044LEX-001	Original Issue