

FCC Test Report

(PART 27)

Report No.: RF180704C07

FCC ID: 2AAGMNB01Q0

Test Model: NB01Q0

Received Date: Jul. 04, 2018

Test Date: Aug. 10, 2018

Issued Date: Aug. 15, 2018

Applicant: SEQUANS Communications

Address: Les portes de la Défense – Hall A, 15/55 boulevard Charles de Gaulle,
92700 Colombes, France

Issued By: Bureau Veritas Consumer Products Services (H.K.) Ltd., Taoyuan Branch

Lab Address: No. 47-2, 14th Ling, Chia Pau Vil., Lin Kou Dist., New Taipei City, Taiwan
(R.O.C)

Test Location: No. 19, Hwa Ya 2nd Rd, Wen Hwa Vil, Kwei Shan Dist., Taoyuan City
33383, Taiwan (R.O.C)

**FCC Registration /
Designation Number:** 788550 / TW0003



This report is for your exclusive use. Any copying or replication of this report to or for any other person or entity, or use of our name or trademark, is permitted only with our prior written permission. This report sets forth our findings solely with respect to the test samples identified herein. The results set forth in this report are not indicative or representative of the quality or characteristics of the lot from which a test sample was taken or any similar or identical product unless specifically and expressly noted. Our report includes all of the tests requested by you and the results thereof based upon the information that you provided to us. You have 60 days from date of issuance of this report to notify us of any material error or omission caused by our negligence, provided, however, that such notice shall be in writing and shall specifically address the issue you wish to raise. A failure to raise such issue within the prescribed time shall constitute your unqualified acceptance of the completeness of this report, the tests conducted and the correctness of the report contents. Unless specific mention, the uncertainty of measurement has been explicitly taken into account to declare the compliance or non-compliance to the specification. The report must not be used by the client to claim product certification, approval, or endorsement by TAF or any government agencies

Table of Contents

Release Control Record	3
1 Certificate of Conformity	4
2 Summary of Test Results.....	5
2.1 Measurement Uncertainty.....	5
2.2 Test Site and Instruments	6
3 General Information	7
3.1 General Description of EUT	7
3.2 Configuration of System under Test.....	8
3.2.1 Description of Support Units	8
3.3 Test Mode Applicability and Tested Channel Detail	9
3.4 EUT Operating Conditions	10
3.5 General Description of Applied Standards.....	10
4 Test Types and Results	11
4.1 Output Power Measurement.....	11
4.1.1 Limits of Output Power Measurement	11
4.1.2 Test Procedures.....	11
4.1.3 Test Setup.....	12
4.1.4 Test Results	13
4.2 Frequency Stability Measurement	14
4.2.1 Limits of Frequency Stability Measurement	14
4.2.2 Test Procedure	14
4.2.3 Test Setup.....	14
4.2.4 Test Results	15
4.3 Occupied Bandwidth Measurement.....	16
4.3.1 Limits of Occupied Bandwidth Measurement	16
4.3.2 Test Procedure	16
4.3.3 Test Setup.....	16
4.3.4 Test Result	17
4.4 Band Edge Measurement	18
4.4.1 Limits of Band Edge Measurement	18
4.4.2 Test Setup.....	18
4.4.3 Test Procedures.....	18
4.4.4 Test Results	19
4.5 Peak to Average Ratio	21
4.5.1 Limits of Peak to Average Ratio Measurement	21
4.5.2 Test Setup.....	21
4.5.3 Test Procedures.....	21
4.5.4 Test Results	22
4.6 Conducted Spurious Emissions.....	23
4.6.1 Limits of Conducted Spurious Emissions Measurement.....	23
4.6.2 Test Setup.....	23
4.6.3 Test Procedure	23
4.6.4 Test Results	24
4.7 Radiated Emission Measurement.....	27
4.7.1 Limits of Radiated Emission Measurement	27
4.7.2 Test Procedure	27
4.7.3 Deviation from Test Standard	27
4.7.4 Test Setup.....	28
4.7.5 Test Results	29
5 Pictures of Test Arrangements.....	35
Appendix – Information on the Testing Laboratories	36

Release Control Record

Issue No.	Description	Date Issued
RF180704C07	Original Release	Aug. 15, 2018

1 Certificate of Conformity

Product: NB01Q

Brand: SEQUANS

Test Model: NB01Q0

Sample Status: Identical Prototype

Applicant: SEQUANS Communications

Test Date: Aug. 10, 2018

Standards: FCC Part 27, Subpart C, K

The above equipment has been tested by **Bureau Veritas Consumer Products Services (H.K.) Ltd., Taoyuan Branch**, and found compliance with the requirement of the above standards. The test record, data evaluation & Equipment Under Test (EUT) configurations represented herein are true and accurate accounts of the measurements of the sample's RF characteristics under the conditions specified in this report.

Prepared by : Gina Liu , **Date:** Aug. 15, 2018
Gina Liu / Specialist

Approved by : Dylan Chiou , **Date:** Aug. 15, 2018
Dylan Chiou / Project Engineer

2 Summary of Test Results

Applied Standard: FCC Part 2 & Part 27			
FCC Clause	Test Item	Result	Remarks
2.1046 27.50(d)(9)	Maximum Peak Output Power	Pass	Meet the requirement of limit.
2.1055 27.54	Frequency Stability	Pass	Meet the requirement of limit.
2.1049	Occupied Bandwidth	Pass	Meet the requirement of limit.
27.50(d)(5)	Peak to Average Ratio	Pass	Meet the requirement of limit.
2.1051 27.53(h)	Band Edge Measurements	Pass	Meet the requirement of limit.
2.1051 27.53(h)	Conducted Spurious Emissions	Pass	Meet the requirement of limit.
2.1053 27.53(h)	Radiated Spurious Emissions	Pass	Meet the requirement of limit. Minimum passing margin is -27.73 dB at 41.64 MHz.

2.1 Measurement Uncertainty

Where relevant, the following measurement uncertainty levels have been estimated for tests performed on the EUT as specified in CISPR 16-4-2:

Measurement	Frequency	Expanded Uncertainty (k=2) (±)
Radiated Emissions up to 1 GHz	30 MHz ~ 200 MHz	2.93 dB
	200 MHz ~ 1000 MHz	2.95 dB
Radiated Emissions above 1 GHz	1 GHz ~ 18 GHz	2.26 dB
	18 GHz ~ 40 GHz	1.94 dB

2.2 Test Site and Instruments

Description & Manufacturer	Model No.	Serial No.	Date of Calibration	Due Date of Calibration
Test Receiver Agilent	N9038A	MY51210203	Mar. 16, 2018	Mar. 15, 2019
Spectrum Analyzer Agilent	N9010A	MY52220314	Nov. 24, 2017	Nov. 23, 2018
Spectrum Analyzer ROHDE & SCHWARZ	FSU43	101261	Jan. 11, 2018	Jan. 10, 2019
Broadband Horn Antenna SCHWARZBECK	BBHA 9170	148	Dec. 13, 2017	Dec. 12, 2018
HORN Antenna SCHWARZBECK	BBHA 9120D	9120D-969	Dec. 12, 2017	Dec. 11, 2018
BILOG Antenna SCHWARZBECK	VULB 9168	9168-472	Dec. 06, 2017	Dec. 05, 2018
Radio Communication Analyzer Anritsu	MT8821C	6201502978	Oct. 13, 2017	Oct. 12, 2018
Preamplifier EMCI	EMC 012645	980115	Oct. 20, 2017	Oct. 19, 2018
Preamplifier EMCI	EMC 184045	980116	Oct. 20, 2017	Oct. 19, 2018
Preamplifier EMCI	EMC 330H	980112	Oct. 13, 2017	Oct. 12, 2018
Power Meter Anritsu	ML2495A	1012010	Aug. 15, 2017	Aug. 14, 2018
Power Sensor Anritsu	MA2411B	1315050	Aug. 15, 2017	Aug. 14, 2018
RF Coaxial Cable HUBER+SUHNNER	EMC104-SM-SM-8000 &3000	140811+170717	Oct. 20, 2017	Oct. 19, 2018
RF Coaxial Cable HUBER+SUHNNER	SUCOFLEX 104	EMC104-SM-SM-10 00(140807)	Oct. 20, 2017	Oct. 19, 2018
RF Coaxial Cable Worken	8D-FB	Cable-Ch10-01	Oct. 20, 2017	Oct. 19, 2018
Software BV ADT	E3 6.120103	NA	NA	NA
Antenna Tower MF	MFA-440H	NA	NA	NA
Turn Table MF	MFT-201SS	NA	NA	NA
Antenna Tower & Turn Table Controller MF	MF-7802	NA	NA	NA
DC Power Supply Topward	33010D	807748	Oct. 25, 2016	Oct. 24, 2018
STANDARD TEMPERATURE & HUMIDITY CHAMBER TERCHY	MHU-225AU	920842	Jun. 01, 2018	May 30, 2019

- Note: 1. The calibration interval of the above test instruments is 12 / 24 months and the calibrations are traceable to NML/ROC and NIST/USA.
2. The test was performed in HwaYa Chamber 10.
3. The horn antenna and preamplifier (model: EMC 184045) are used only for the measurement of emission frequency above 1 GHz if tested.
4. The IC Site Registration No. is IC7450F-10.

3 General Information

3.1 General Description of EUT

Product	NB01Q	
Brand	SEQUANS	
Test Model	NB01Q0	
Status of EUT	Identical Prototype	
Power Supply Rating	3.1~4.5 Vdc (Host Equipment)	
Modulation Type	LTE	QPSK, BPSK
Frequency Range	LTE Band PCS-H block	1915 ~ 1920 MHz
Emission Designator	LTE Band PCS-H block (BPSK)	69K55F9W
	LTE Band PCS-H block (QPSK)	195K40F9W
Max. EIRP Power	LTE Band PCS-H block (BPSK)	297.17 mW
	LTE Band PCS-H block (QPSK)	230.67 mW
Antenna Type	Fixed External Antenna	
Antenna Gain	LTE Band PCS-H block	2.79 dBi
Accessory Device	N/A	
Data Cable Supplied	N/A	

Note:

1. The above EUT information is declared by manufacturer and for more detailed features description, please refers to the manufacturer's specifications or user's manual.

3.2 Configuration of System under Test

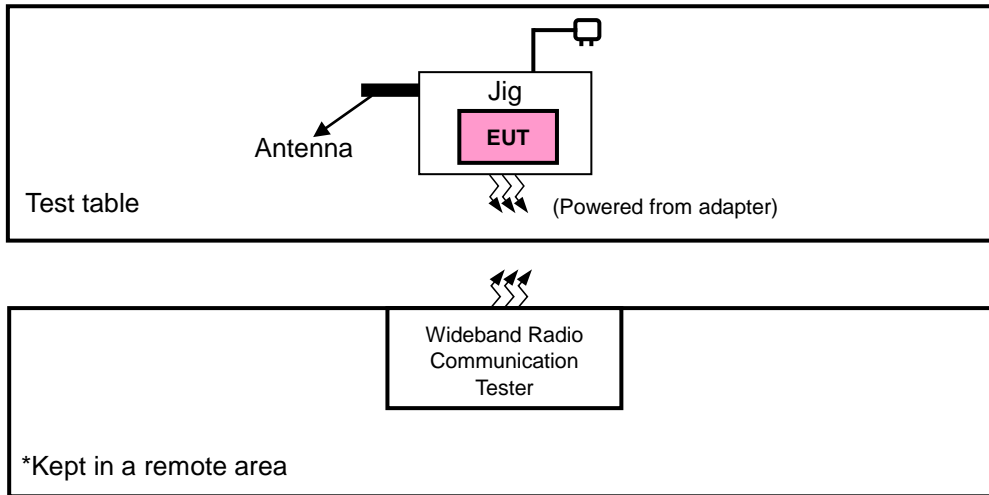

3.2.1 Description of Support Units

The EUT has been tested as an independent unit together with other necessary accessories or support units. The following support units or accessories were used to form a representative test configuration during the tests.

No.	Product	Brand	Model No.	Serial No.	FCC ID
1.	Jig	N/A	N/A	N/A	N/A
2.	Antenna	Taoglas	TG.08.0113	N/A	N/A
3.	Adapter	N/A	N/A	N/A	N/A
4.	Wideband Radio Communication Tester	R&S	CMW500	N/A	N/A

No.	Signal Cable Description Of The Above Support Units
1.	N/A
2.	N/A
3.	1.45m non-shielded cable 1 core
4.	N/A

Note:

1. All power cords of the above support units are non-shielded (1.8m).
2. Item 1~3 was provided by client.
3. Item 4 acted as communication partners to transfer data.

3.3 Test Mode Applicability and Tested Channel Detail

Pre-Scan has been conducted to determine the worst-case mode from all possible combinations between available modulations, data rates, XYZ axis, and antenna ports

The worst case was found when positioned as the table below. Following channel(s) was (were) selected for the final test as listed below:

Band	ERP / EIRP	Radiated Emission
LTE Band PCS-H block	X-plane	X-axis

LTE Band PCS-H block

EUT Configure Mode	Test Item	Available Channel	Tested Channel	Sub-carrier Spacing (kHz)	Modulation	N _{tones}		
-	EIRP	32112 to 32160	32112, 32136, 32160	3.75	BPSK	1@0		
				15	QPSK	3@3		
-	Frequency Stability	32112 to 32160	32112, 32160	15	QPSK	3@3		
-	Occupied Bandwidth	32112 to 32160	32112	3.75	BPSK	1@0		
				15	QPSK	1@0		
						3@3		
						12@0		
				32112 to 32160	32136	3.75	BPSK	1@0
						15	QPSK	1@0
		3@3						
		32112 to 32160	32160	3.75	BPSK	1@47		
						15	QPSK	1@11
								3@3
				15	QPSK	12@0		
						3.75	BPSK	1@0
15	QPSK							1@0
-	Peak to Average Ratio	32112 to 32160	32136	15	QPSK	3@3		
				3.75	BPSK	1@0		
-	Band Edge	32112 to 32160	32112	15	QPSK	1@0		
						3@3		
				12@0	32160	3.75	BPSK	1@47
								15
		3@3						
		12@0						
		-	Conducted Emission	32112 to 32160	32112, 32136, 32160	15	QPSK	3@3
		-	Radiated Emission	32112 to 32160	32112, 32136, 32160	15	QPSK	3@3

Note: This device was tested under all bandwidths, RB configurations and modulations. The worst case was found in QPSK modulation.

Test Condition:

Test Item	Environmental Conditions	Input Power	Tested By
EIRP	25 deg. C, 65 % RH	12 Vdc	Getaz Yang
Frequency Stability	25 deg. C, 65 % RH	12 Vdc	Getaz Yang
Occupied Bandwidth	25 deg. C, 65 % RH	12 Vdc	Getaz Yang
Band Edge	25 deg. C, 65 % RH	12 Vdc	Getaz Yang
Peak to Average Ratio	25 deg. C, 65 % RH	12 Vdc	Getaz Yang
Conducted Emission	25 deg. C, 65 % RH	12 Vdc	Getaz Yang
Radiated Emission	25 deg. C, 65 % RH	120 Vac, 60 Hz	Thomas Wei

3.4 EUT Operating Conditions

The EUT makes a call to the communication simulator. The communication simulator station system controlled a EUT to export maximum output power under transmission mode and specific channel frequency

3.5 General Description of Applied Standards

The EUT is a RF Product. According to the specifications of the manufacturer, it must comply with the requirements of the following standards:

FCC 47 CFR Part 2

FCC 47 CFR Part 27

KDB 971168 D01 Power Meas License Digital Systems v03r01

ANSI/TIA/EIA-603-E 2016

ANSI 63.26-2015

Note: All test items have been performed and recorded as per the above standards.

4 Test Types and Results

4.1 Output Power Measurement

4.1.1 Limits of Output Power Measurement

Fixed, mobile, and portable (hand-held) stations operating in the 1915–1920 MHz band are limited to 300 milliwatts EIRP.

4.1.2 Test Procedures

EIRP / ERP Measurement:

- a. All measurements were done at low, middle and high operational frequency range. RBW and VBW is 10 MHz for LTE mode.
- b. Substitution method is used for E.I.R.P measurement. In the semi-anechoic chamber, EUT placed on the 0.8 m (below or equal 1 GHz) and/or 1.5 m (above 1 GHz) height of Turn Table, rotated the table around 360 degrees to search the maximum radiation power and receiver antenna shall be rotated vertical and horizontal polarization and moved height from 1 m to 4 m to find the maximum polar radiated power. The “Read Value” is the spectrum reading the maximum power value.
- c. The substitution horn antenna is substituted for EUT at the same position and signals generator export the CW signal to the substitution antenna via a tx cable. Rotated the Turn Table and moved receiving antenna to find the maximum radiation power. Adjust output power level of S.G to get a Value of spectrum reading equal to “Read Value” of step b. Record the power level of S.G.
- d. $EIRP = \text{Output power level of S.G} - \text{TX cable loss} + \text{Antenna gain of substitution horn}$. E.R.P power can be calculated form E.I.R.P power by subtracting the gain of dipole, $E.R.P \text{ power} = E.I.R.P \text{ power} - 2.15 \text{ dB}$.

Conducted Power Measurement:

- a. The EUT was set up for the maximum power with LTE link data modulation and link up with simulator.
- b. Set the EUT to transmit under low, middle and high channel and record the power level shown on simulator.

4.1.3 Test Setup

EIRP / ERP Measurement:

<Radiated Emission below or equal 1 GHz>

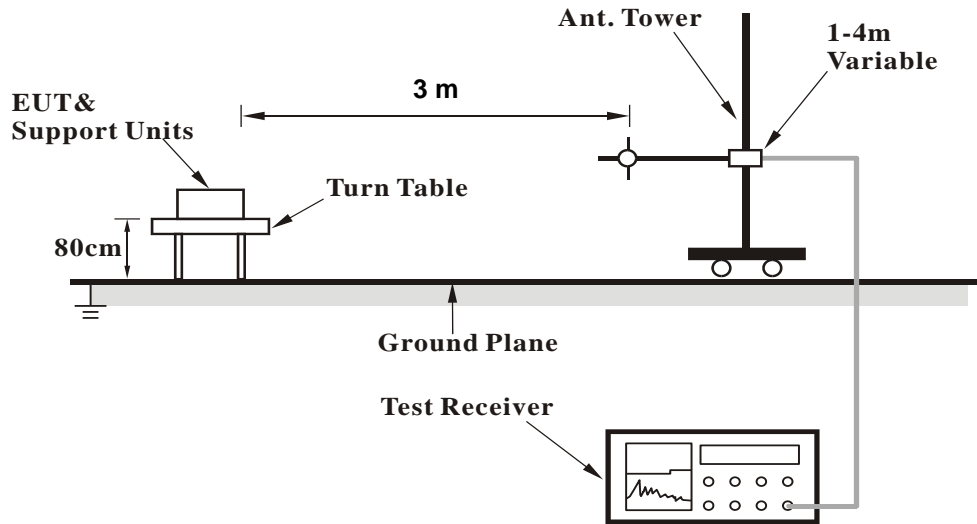

<Radiated Emission above 1 GHz>

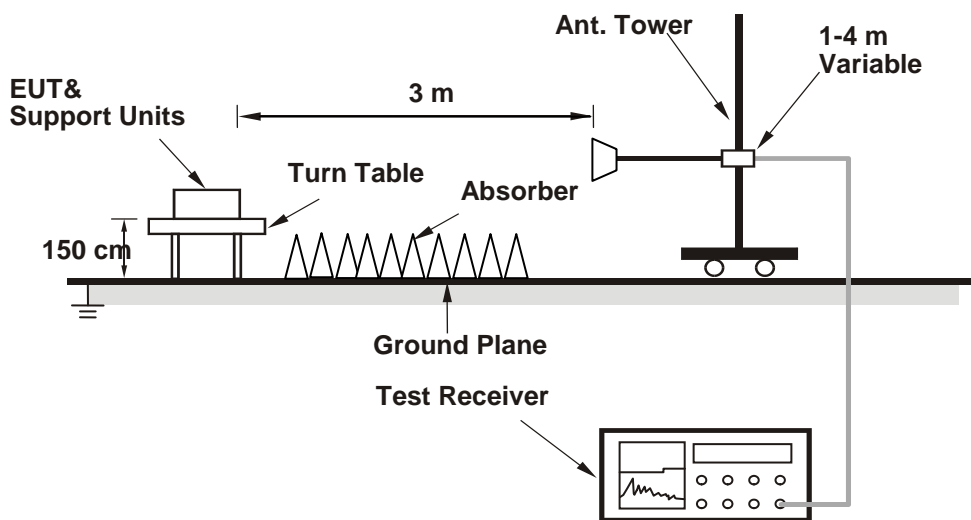

For the actual test configuration, please refer to the attached file (Test Setup Photo).

Conducted Power Measurement:

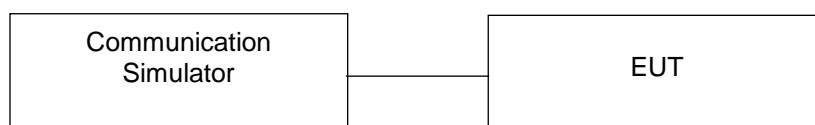

4.1.4 Test Results

Conducted Output Power (dBm)

Test Frequency ID	N _{UL}	M _{UL}	Frequency of Uplink [MHz]	N _{DL}	M _{DL}	Frequency of Downlink [MHz]	Test Configuration Initial of Power			EUT	
							Modulation	Ntones	Sub-carrier spacing (kHz)	Cell power (dBm/15kHz)	power (dBm)
Low Range	32112	0	1915.1	11131	-0.5	722.1	BPSK	1@0	3.75	-110	23.26
							QPSK	1@0	15	-120	22.06
							QPSK	3@3	15	-115	22.56
Mid Range	32136	0	1917.5	11156	-0.5	724.6	BPSK	1@0	3.75	-110	23.02
							BPSK	1@47	3.75	-110	22.44
							QPSK	1@0	15	-120	22.12
							QPSK	1@11	15	-120	21.87
							QPSK	3@3	15	-115	21.33
High Range	32160	0	1919.9	11181	-0.5	727.1	BPSK	1@47	3.75	-110	22.66
							QPSK	1@11	15	-120	21.73
							QPSK	3@3	15	-115	21.23

EIRP Power (dBm)

LTE Band PCS-H block							
Modulation: QPSK							
Plane	Channel	Frequency (MHz)	Reading (dBm)	Correction Factor (dB)	EIRP (dBm)	EIRP (mW)	Polarization (H/V)
X	32112	1915.1	-11.84	36.57	24.73	297.17	H
	32136	1917.5	-12.80	37.22	24.42	276.69	
	32160	1919.9	-12.89	37.18	24.29	268.53	
	32112	1915.1	-17.67	37.65	19.98	99.54	V
	32136	1917.5	-17.93	37.58	19.65	92.26	
	32160	1919.9	-18.30	37.48	19.18	82.79	
Modulation: BPSK							
X	32112	1915.1	-12.94	36.57	23.63	230.67	H
	32136	1917.5	-13.90	37.22	23.32	214.78	
	32160	1919.9	-13.99	37.18	23.19	208.45	
	32112	1915.1	-18.77	37.65	18.88	77.27	V
	32136	1917.5	-19.03	37.58	18.55	71.61	
	32160	1919.9	-19.40	37.48	18.08	64.27	

Note: EIRP (dBm) = Reading (dBm) + Correction Factor (dB)

4.2 Frequency Stability Measurement

4.2.1 Limits of Frequency Stability Measurement

The frequency stability shall be sufficient to ensure that the fundamental emissions stay within the authorized bands of operation.

4.2.2 Test Procedure

- Device is placed at the oven room. The oven room could control the temperatures and humidity. Power warm up is at least 15 min and power applied should perform before recording frequency error.
- EUT is connected the external power supply to control the DC input power. The test voltage range is from minimum to maximum working voltage. Each step shall be record the frequency error rate.
- The temperature range step is 10 degrees in this test items. All temperature levels shall be hold the ± 0.5 °C during the measurement testing. The each temperature step shall be at least 0.5 hours, consider the EUT could be test under the stability condition.

Note: The frequency error was recorded frequency error from the communication simulator.

4.2.3 Test Setup

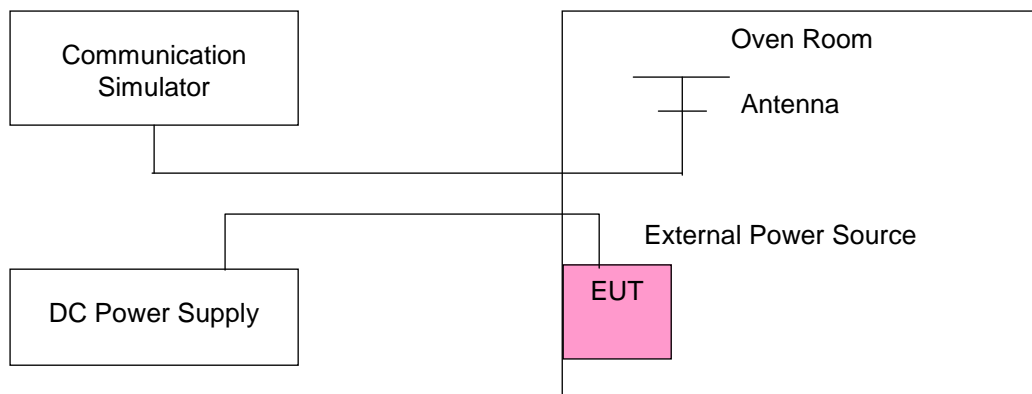

4.2.4 Test Results

Frequency Error vs. Voltage

Voltage (Volts)	LTE Band PCS-H block				Limit (ppm)
	QPSK				
	Low Channel		High Channel		
	Frequency (MHz)	Frequency Error (ppm)	Frequency (MHz)	Frequency Error (ppm)	
10.2	1917.500001	0.001	1917.500004	0.002	2.5
12.0	1917.500002	0.001	1917.500001	0.001	2.5
13.8	1917.500003	0.001	1917.500004	0.002	2.5

Note: The applicant defined the normal working voltage of the adapter is from 10.2 Vdc to 13.8 Vdc.

Frequency Error vs. Temperature

Temp. (°C)	LTE Band PCS-H block				Limit (ppm)
	QPSK				
	Low Channel		High Channel		
	Frequency (MHz)	Frequency Error (ppm)	Frequency (MHz)	Frequency Error (ppm)	
-30	1917.500002	0.001	1917.500002	0.001	2.5
-20	1917.500002	0.001	1917.500002	0.001	2.5
-10	1917.500004	0.002	1917.500004	0.002	2.5
0	1917.500001	0.001	1917.500004	0.002	2.5
10	1917.500002	0.001	1917.500004	0.002	2.5
20	1917.499999	-0.001	1917.499997	-0.002	2.5
30	1917.499996	-0.002	1917.499997	-0.002	2.5
40	1917.499997	-0.001	1917.499997	-0.001	2.5
50	1917.499999	-0.001	1917.499999	-0.001	2.5

4.3 Occupied Bandwidth Measurement

4.3.1 Limits of Occupied Bandwidth Measurement

The width of a frequency band such that, below the lower and above the upper frequency limits, the mean powers emitted are each equal to a specified percentage 0.5 % of the total mean power of a given emission.



4.3.2 Test Procedure

- The conducted occupied bandwidth used the power splitter via EUT RF power connector between simulation base station and spectrum analyzer.
- Use OBW measurement function of Spectrum analyzer to measure 99 % occupied bandwidth.

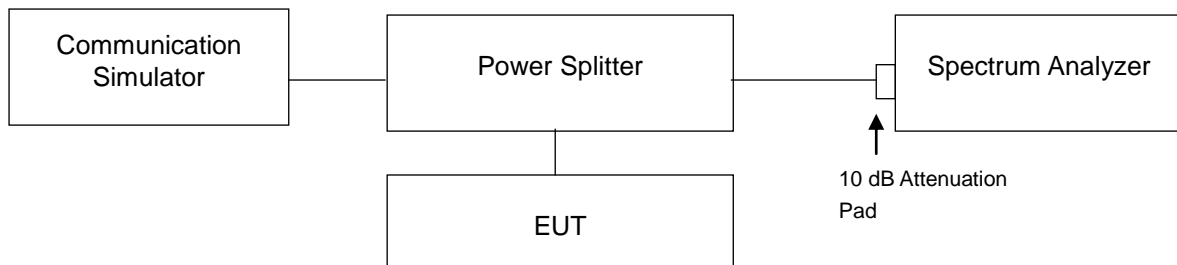
4.3.3 Test Setup

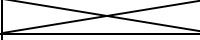

4.3.4 Test Result

LTE Band PCS-H block					
Channel	Frequency (MHz)	Modulation	N _{tones}	Sub-carrier spacing (kHz)	99 % Occupied Bandwidth (kHz)
32112	1915.1	BPSK	1@0	3.75	69.55
		QPSK	1@0	15	126.89
		QPSK	3@3	15	111.95
		QPSK	12@0	15	188.73
32136	1917.5	BPSK	1@0	3.75	69.05
		BPSK	1@47	3.75	
		QPSK	1@0	15	135.86
		QPSK	1@11	15	
		QPSK	3@3	15	111.51
		QPSK	12@0	15	192.10
32160	1919.9	BPSK	1@47	3.75	68.39
		QPSK	1@11	15	133.54
		QPSK	3@3	15	108.92
		QPSK	12@0	15	195.40

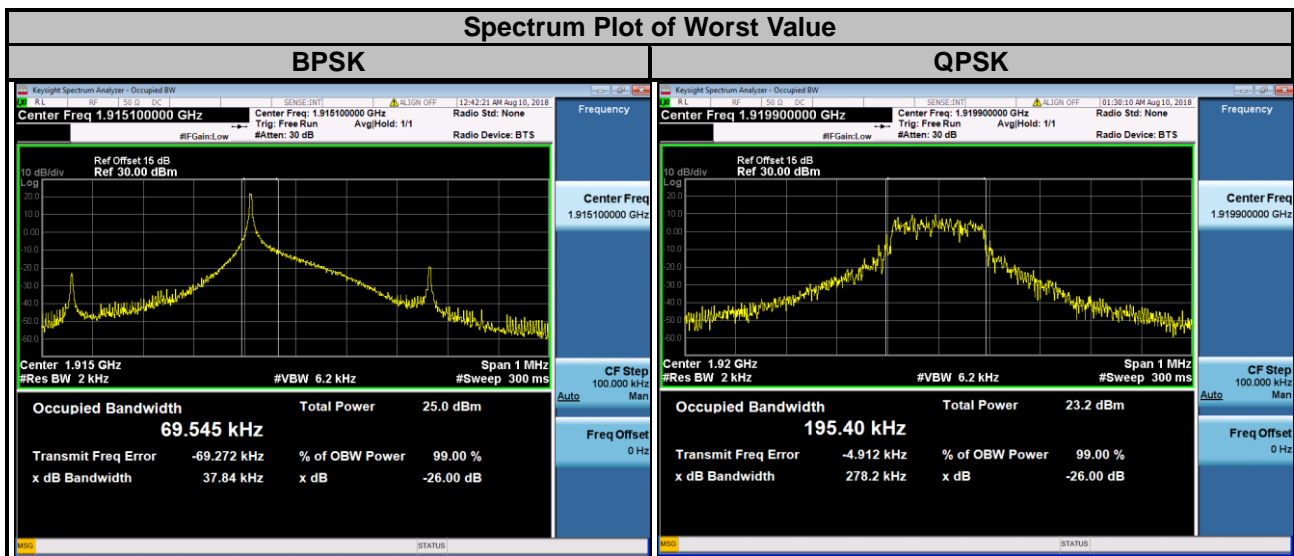

4.4 Band Edge Measurement

4.4.1 Limits of Band Edge Measurement

For operations in the 1915–1920 MHz bands, the power of any emission outside a licensee's frequency block shall be attenuated below the transmitter power (P) by at least $43 + 10 \log (P)$ dB.

4.4.2 Test Setup

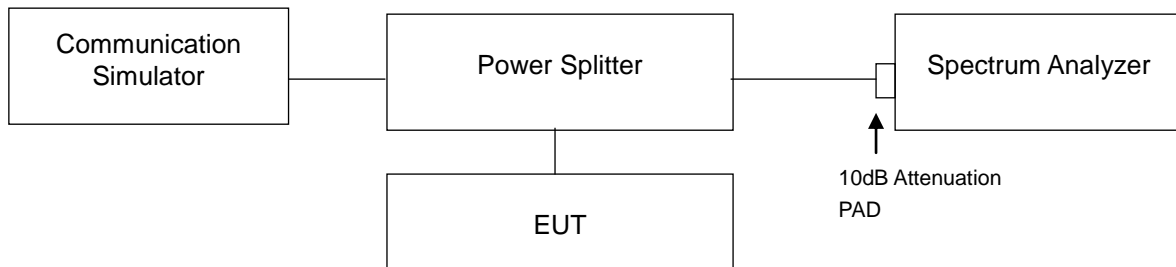

4.4.3 Test Procedures

- a. All measurements were done at low and high operational frequency range.
- b. Record the max. trace plot into the test report.

4.4.4 Test Results

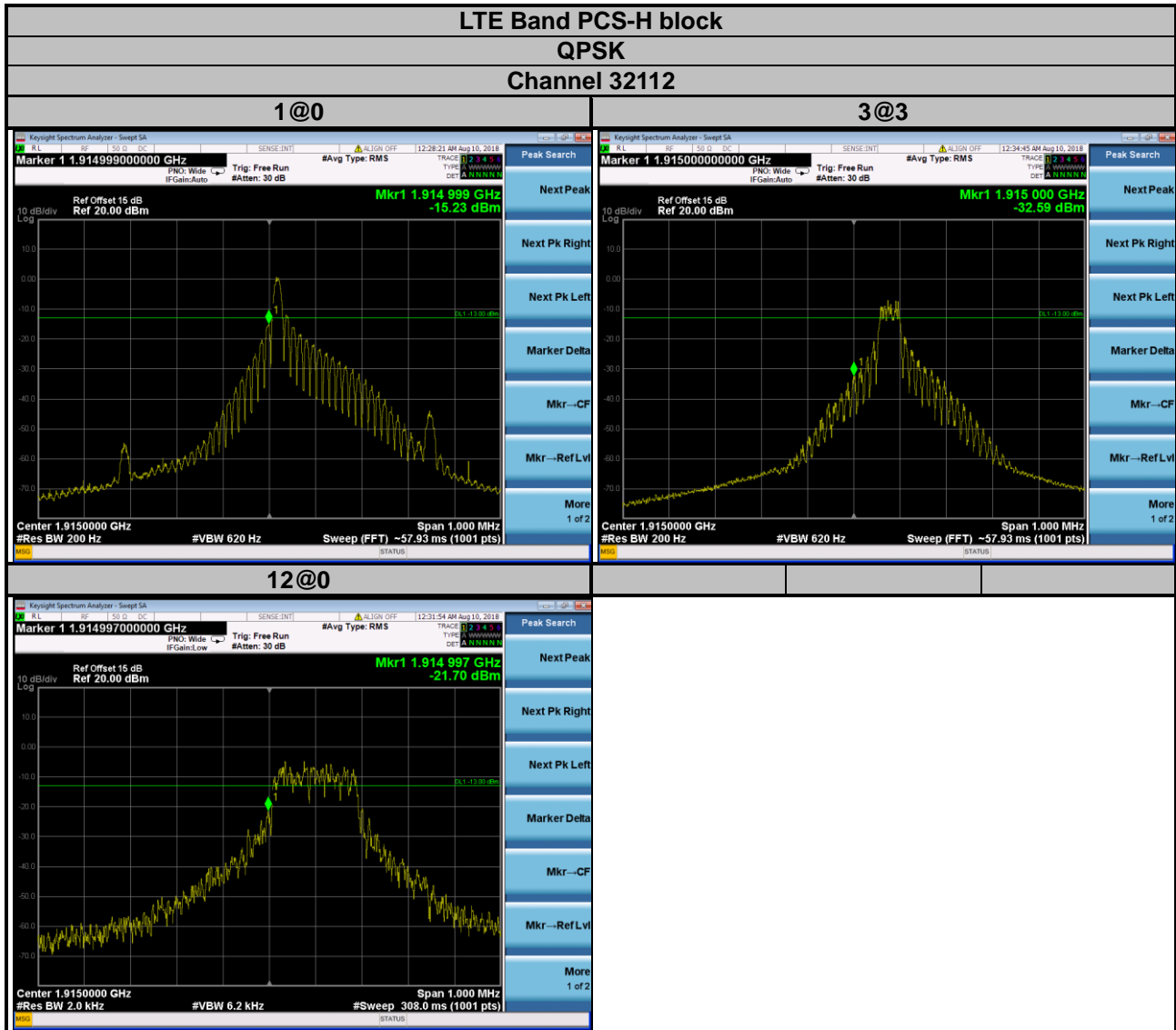

QPSK Channel 32160

1@11

3@3

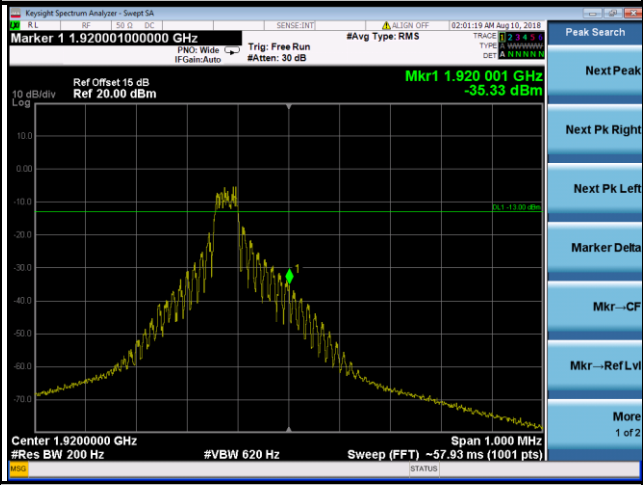
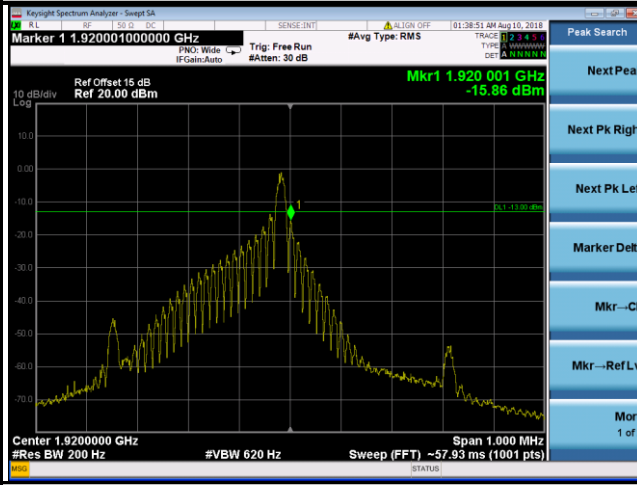

12@0

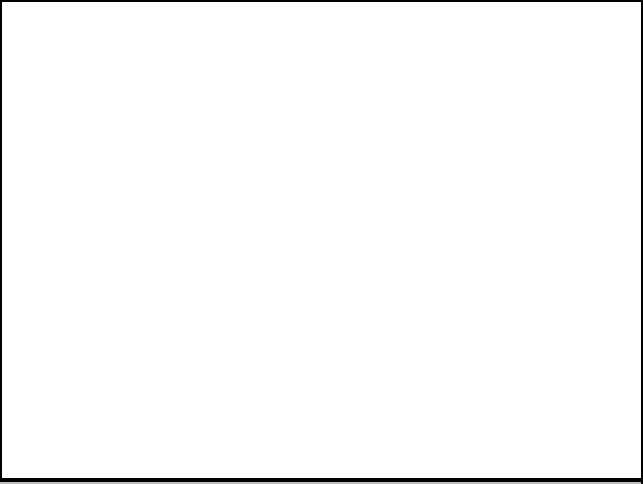
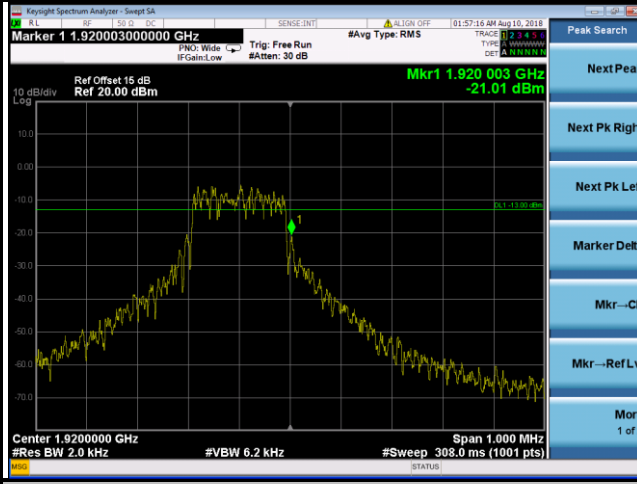

BPSK

1@47

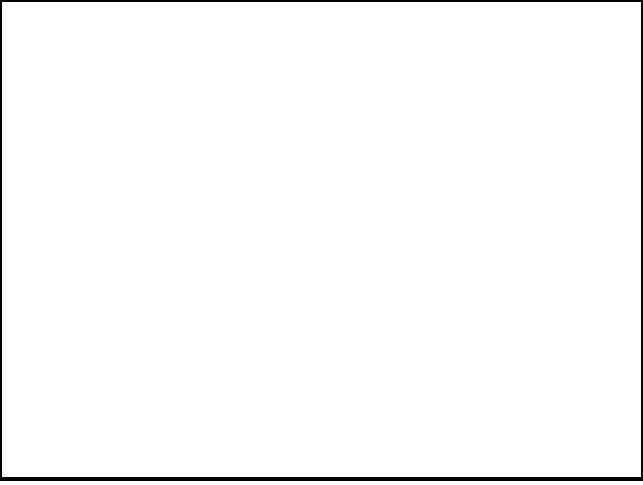
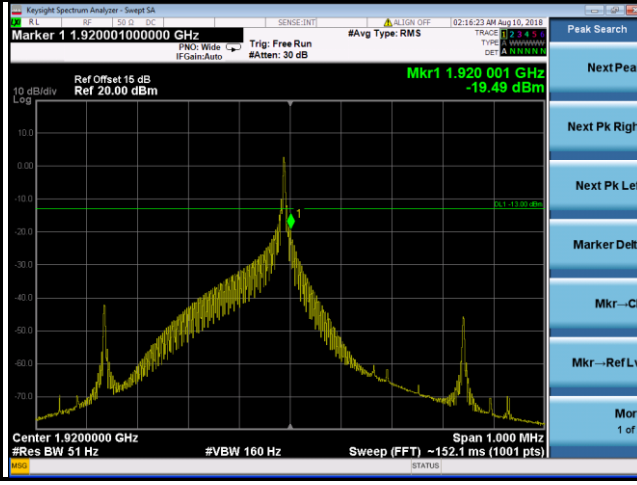

4.5 Peak to Average Ratio

4.5.1 Limits of Peak to Average Ratio Measurement

In measuring transmissions in this band using an average power technique, the peak to-average ratio (PAR) of the transmission may not exceed 13 dB.

4.5.2 Test Setup

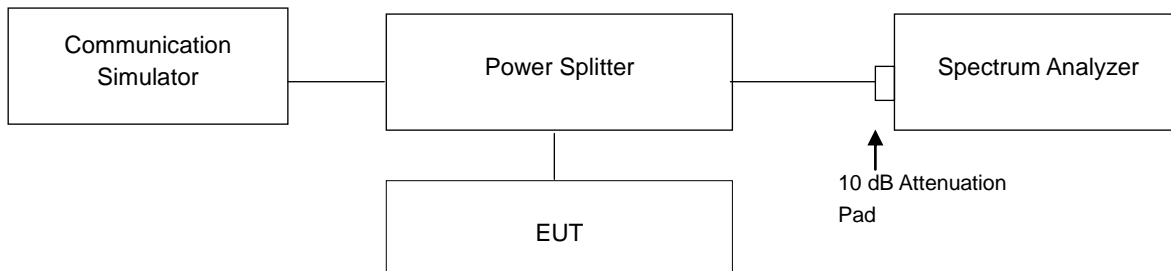

4.5.3 Test Procedures

1. Set resolution/measurement bandwidth \geq signal's occupied bandwidth;
2. Set the number of counts to a value that stabilizes the measured CCDF curve;
3. Record the maximum PAPR level associated with a probability of 0.1 %.

4.5.4 Test Results

LTE Band PCS-H block						
Channel	Frequency (MHz)	Modulation	N _{tones}	Sub-carrier spacing (kHz)	CCDF	Limit
32136	1917.5	BPSK	1@0	3.75	1.93	13.00
32136	1917.5	QPSK	1@0	15	1.86	
32136	1917.5	QPSK	3@3	15	3.56	

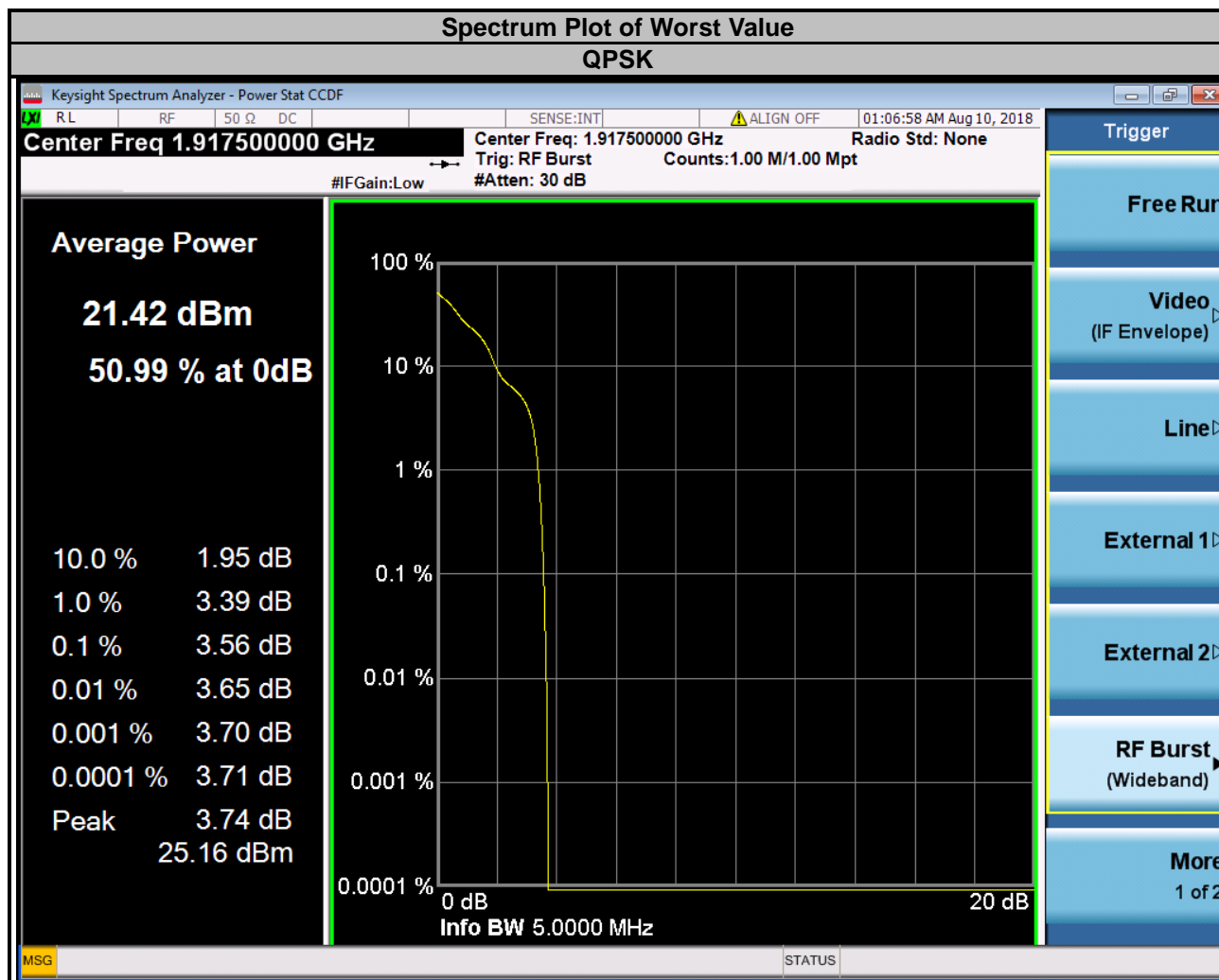

4.6 Conducted Spurious Emissions

4.6.1 Limits of Conducted Spurious Emissions Measurement

The power of any emission outside a licensee's frequency block shall be attenuated below the transmitter power (P) by at least $43 + 10 \log (P)$ dB. The limit of emission is equal to -13 dBm.

4.6.2 Test Setup

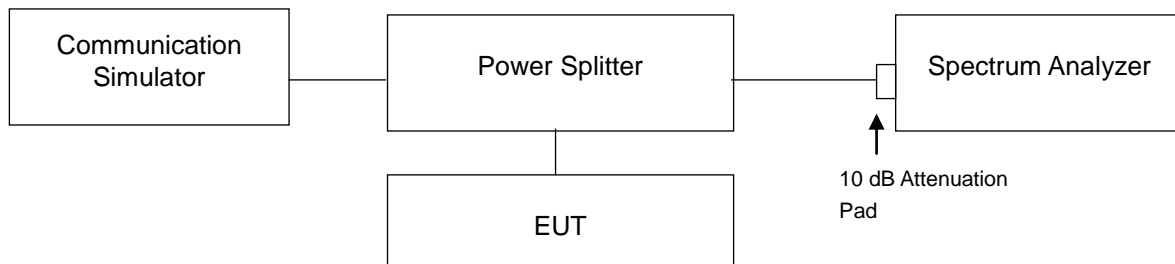

4.6.3 Test Procedure

- The EUT makes a phone call to the communication simulator. All measurements were done at low, middle and high operational frequency range.
- For LTE Band PCS-H block, measuring frequency range is from 9 kHz to 27 GHz. 20 dB attenuation pad is connected with spectrum. Below 1 GHz RBW = 100 kHz and VBW = 300 kHz is used for conducted emission measurement. Above 1 GHz RBW = 1 MHz and VBW = 3 MHz is used for conducted emission measurement.

4.6.4 Test Results

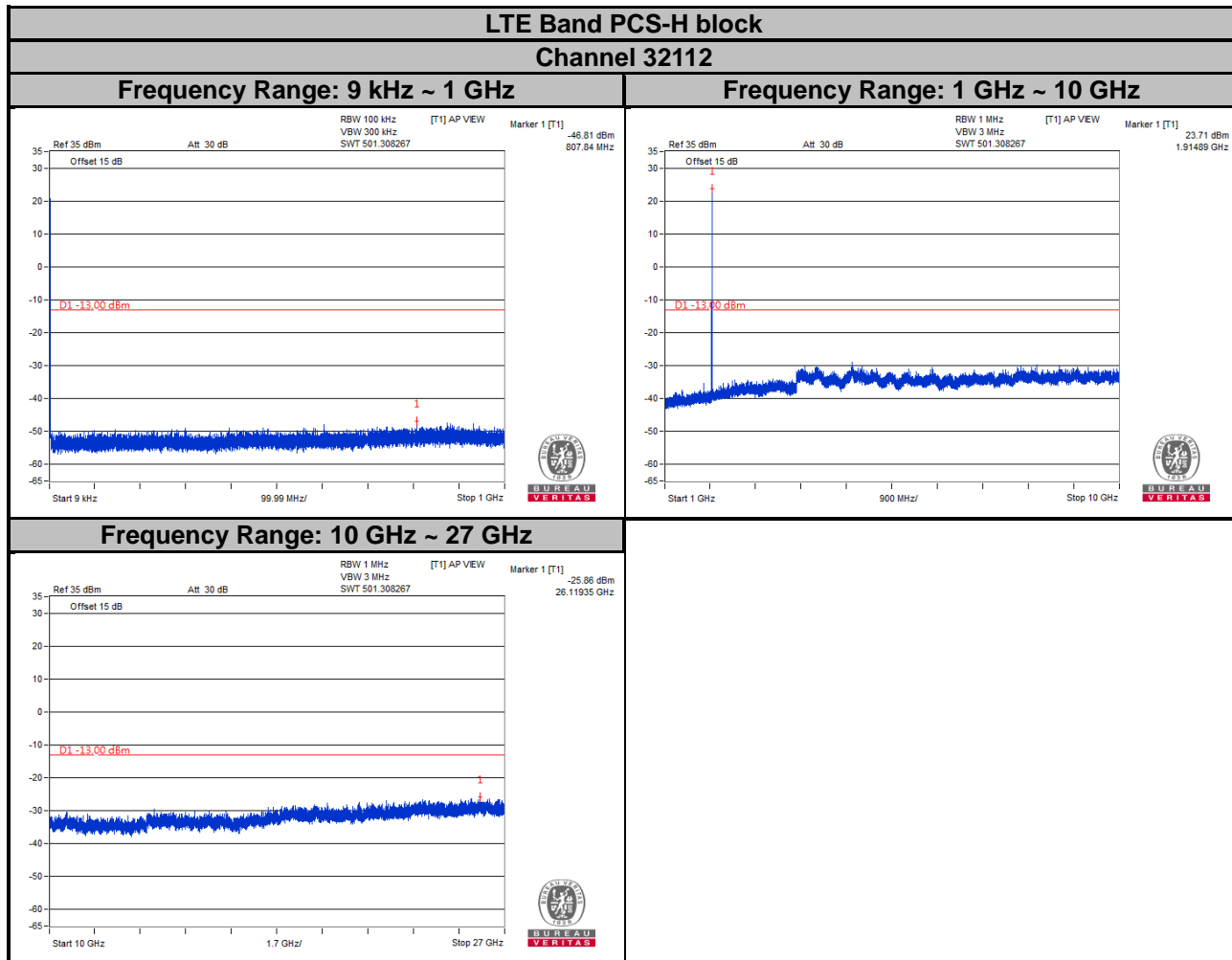

LTE Band PCS-H block

Channel 32136

Frequency Range: 9 kHz ~ 1 GHz

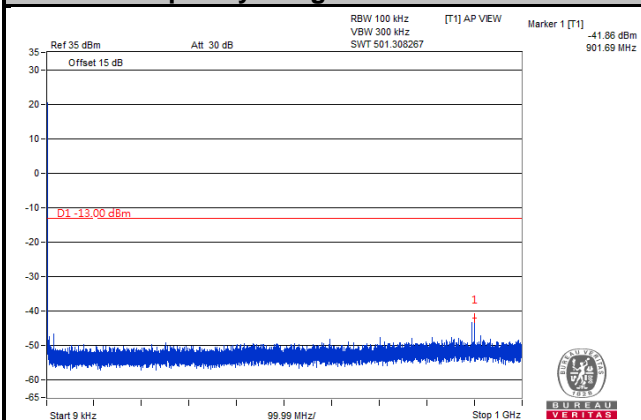

Frequency Range: 1 GHz ~ 10 GHz

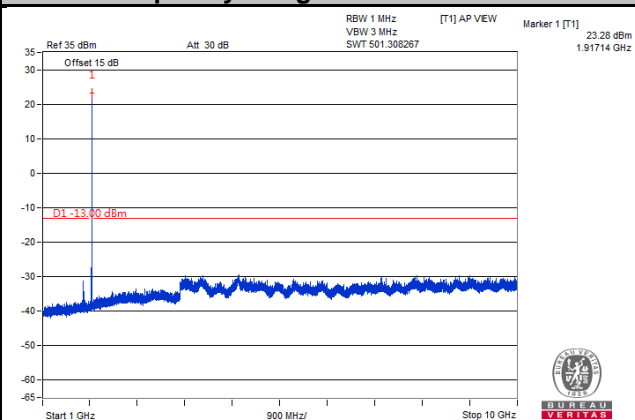

Frequency Range: 10 GHz ~ 27 GHz

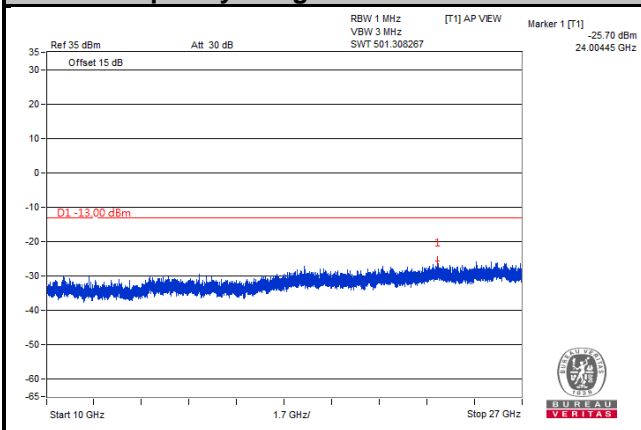

LTE Band PCS-H block

Channel 32160

Frequency Range: 9 kHz ~ 1 GHz

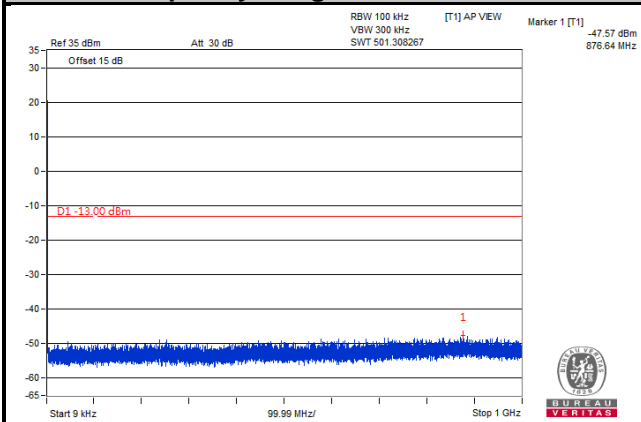

Frequency Range: 1 GHz ~ 10 GHz

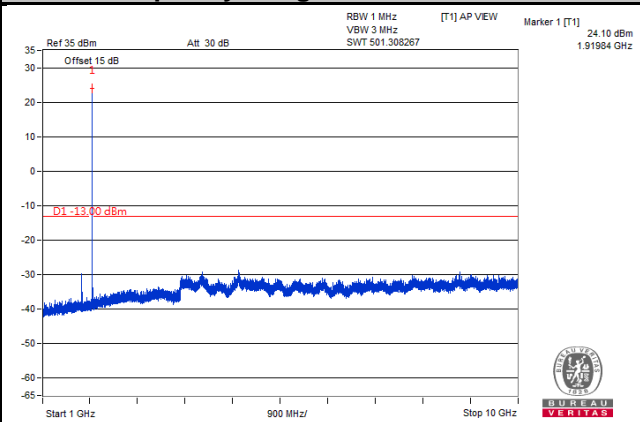

Frequency Range: 10 GHz ~ 27 GHz

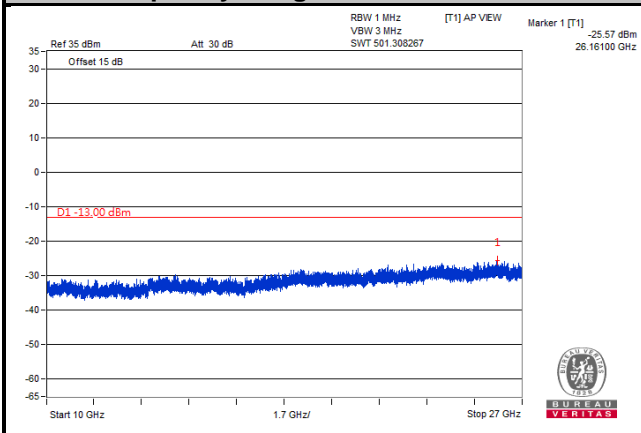

4.7 Radiated Emission Measurement

4.7.1 Limits of Radiated Emission Measurement

- a. The power of any emission outside a licensee's frequency block shall be attenuated below the transmitter power (P) by at least $43 + 10 \log (P)$ dB. The limit of emission is equal to -13 dBm.
- b. For operations in the 1915-1920 MHz. the power of any emission between 1930-1995 MHz shall be attenuated below the transmitter power (P) in watts by at least $70 + 10 \log (P)$ dB. The limit of emission is equal to -40 dBm.

4.7.2 Test Procedure

- a. Substitution method is used for E.I.R.P measurement. In the semi-anechoic chamber, EUT placed on the 0.8 m (below or equal 1 GHz) and/or 1.5 m (above 1 GHz) height of Turn Table, rotated the table around 360 degrees to search the maximum radiation power and receiver antenna shall be rotated vertical and horizontal polarization and moved height from 1 m to 4 m to find the maximum polar radiated power. The "Read Value" is the spectrum reading the maximum power value.
- b. The substitution horn antenna is substituted for EUT at the same position and signals generator export the CW signal to the substitution antenna via a TX cable. Rotated the Turn Table and moved receiving antenna to find the maximum radiation power. Adjust output power level of S.G to get a Value of spectrum reading equal to "Read Value" of step a. Record the power level of S.G.
- c. $EIRP = \text{Output power level of S.G} - \text{TX cable loss} + \text{Antenna gain of substitution horn}$.
- d. E.R.P power can be calculated form E.I.R.P power by subtracting the gain of dipole, $E.R.P \text{ power} = E.I.R.P \text{ power} - 2.15 \text{ dB}$.

Note: The resolution bandwidth of spectrum analyzer is 1 MHz and the video bandwidth is 3 MHz.

4.7.3 Deviation from Test Standard

No deviation.

4.7.4 Test Setup

<Radiated Emission below or equal 1 GHz>

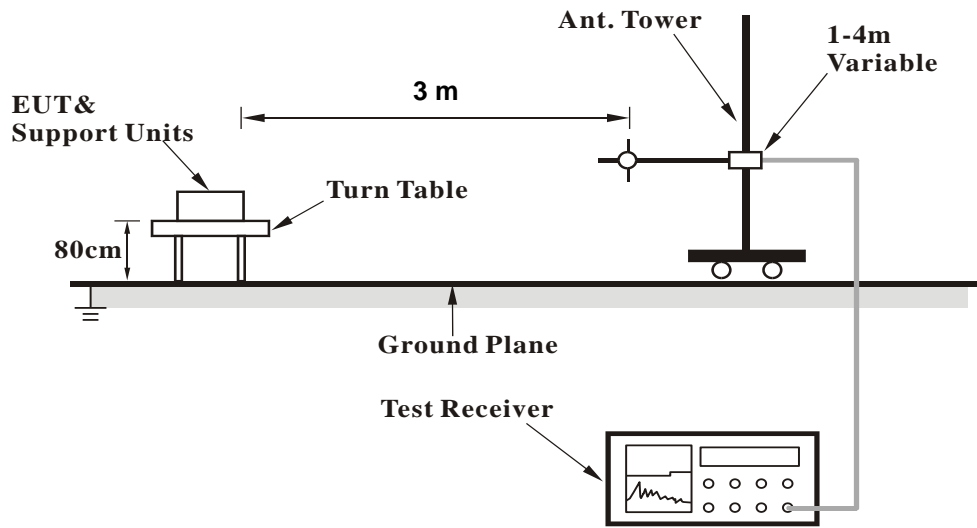

<Radiated Emission above 1 GHz>

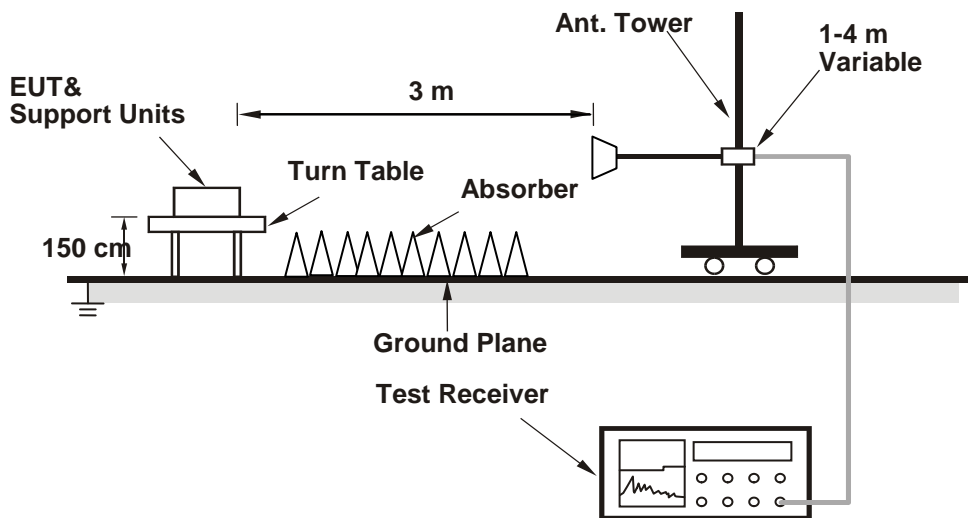

For the actual test configuration, please refer to the attached file (Test Setup Photo).

4.7.5 Test Results

QPSK

Low Channel



Bureau Veritas Consumer Products Services Ltd., Taoyuan Branch

A D T

Data: 3

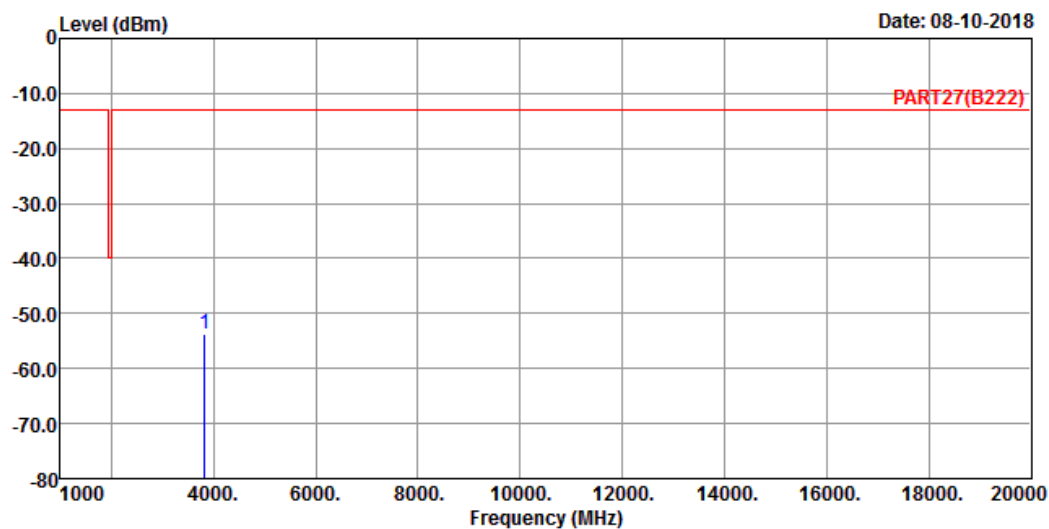

Site : 966 Chamber 5
 Condition: PART27(B222) HORIZONTAL
 Remak : NB-IOT Band 222 Stand-alone_Link_L-Ch
 Tested by: Thomas Wei

Freq	Level	Read Level	Limit Line	Over Limit	Factor	Remark
MHz	dBm	dBm	dBm	dB	dB	
1 pp 3830.20	-53.86	-47.49	-13.00	-40.86	-6.37	Peak



Bureau Veritas Consumer Products Services Ltd., Taoyuan Branch

A D T

Data: 4

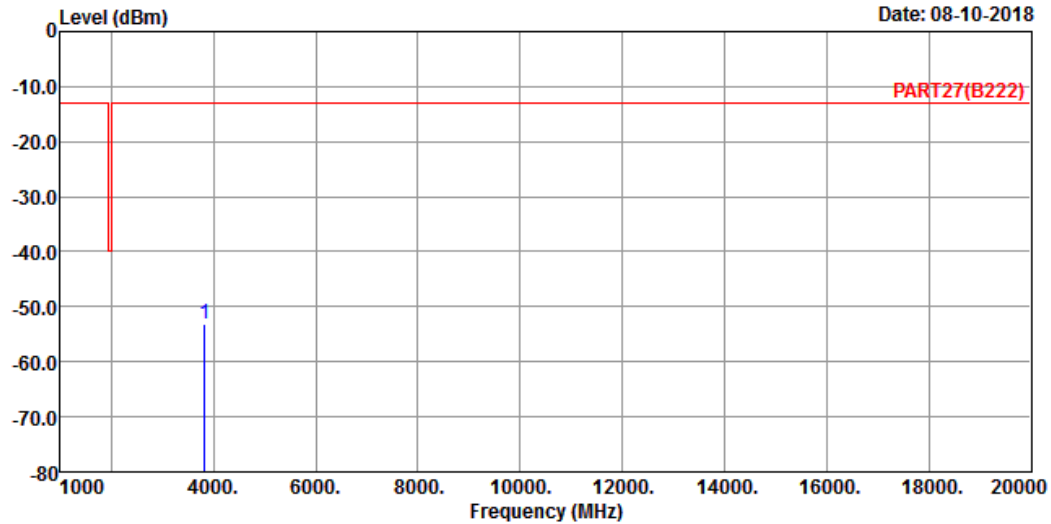

Site : 966 Chamber 5
 Condition: PART27(B222) VERTICAL
 Remak : NB-IOT Band 222 Stand-alone_Link_L-Ch
 Tested by: Thomas Wei

Freq	Level	Read Level	Limit Line	Over Limit	Factor	Remark
MHz	dBm	dBm	dBm	dB	dB	
1 pp 3830.20	-53.20	-46.83	-13.00	-40.20	-6.37	Peak

Middle Channel



Bureau Veritas Consumer Products Services Ltd., Taoyuan Branch

A D T

Data: 3

Date: 08-10-2018

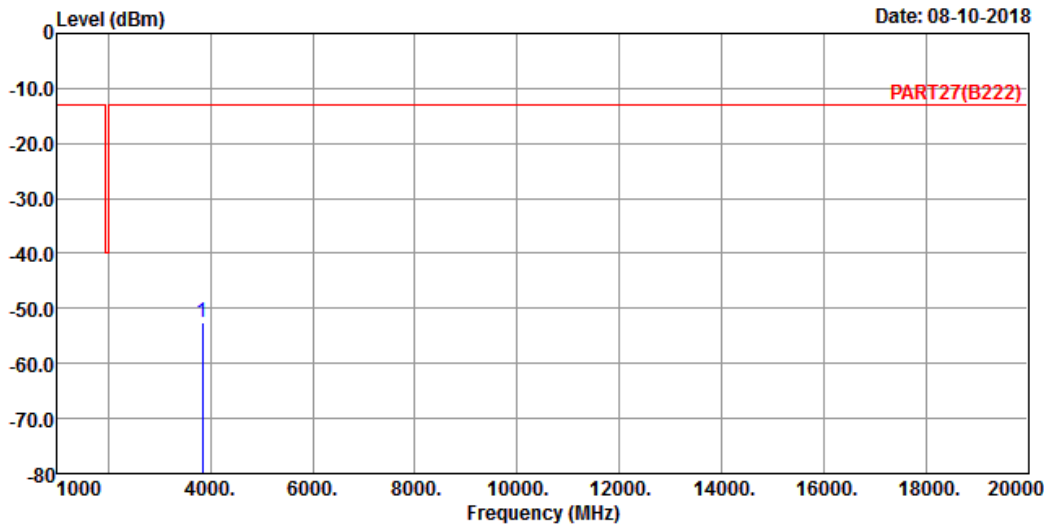

Site : 966 Chamber 5
 Condition: PART27(B222) HORIZONTAL
 Remak : NB-IOT Band 222 Stand-alone_Link_M-Ch
 Tested by: Thomas Wei

	Read	Limit	Over		
Freq	Level	Level	Line	Limit	Factor Remark
MHz	dBm	dBm	dBm	dB	dB
1 pp 3835.00	-52.67	-46.33	-13.00	-39.67	-6.34 Peak



A D T

Data: 4

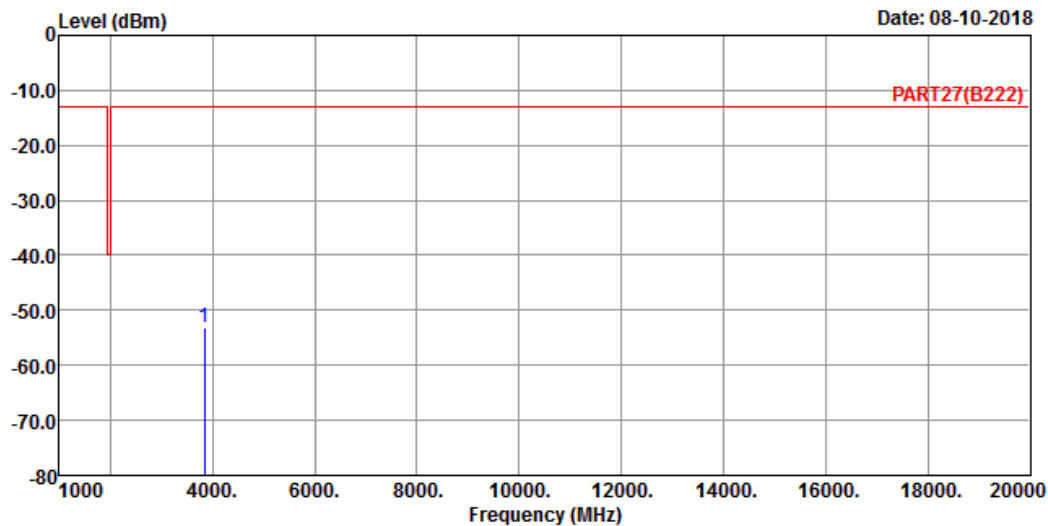

Site : 966 Chamber 5
 Condition: PART27(B222) VERTICAL
 Remak : NB-IOT Band 222 Stand-alone_Link_M-Ch
 Tested by: Thomas Wei

Freq	Level	Read Level	Limit Line	Over Limit	Factor	Remark
MHz	dBm	dBm	dBm	dB	dB	
1 pp 3835.00	-53.18	-53.18	-13.00	-40.18	0.00	Peak

High Channel



Bureau Veritas Consumer Products Services Ltd., Taoyuan Branch

A D T

Data: 5

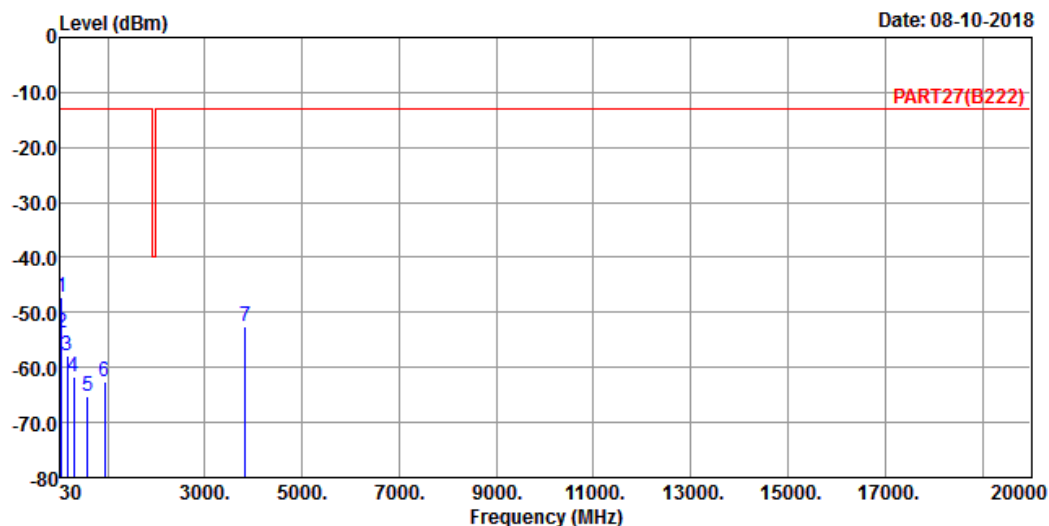

Site : 966 Chamber 5
 Condition: PART27(B222) HORIZONTAL
 Remak : NB-IOT Band 222 Stand-alone_Link_H-Ch
 Tested by: Thomas Wei

	Freq	Level	Read Level	Limit	Over	Factor	Remark
	MHz	dBm	dBm	dBm	dB	dB	
1	pp	44.55	-47.32	-45.33	-13.00	-34.32	-1.99 Peak
2		53.28	-53.59	-47.78	-13.00	-40.59	-5.81 Peak
3		171.62	-57.95	-52.08	-13.00	-44.95	-5.87 Peak
4		294.81	-61.76	-54.85	-13.00	-48.76	-6.91 Peak
5		593.57	-65.20	-64.16	-13.00	-52.20	-1.04 Peak
6		940.83	-62.62	-64.20	-13.00	-49.62	1.58 Peak
7		3839.80	-52.42	-46.08	-13.00	-39.42	-6.34 Peak



Bureau Veritas Consumer Products Services Ltd., Taoyuan Branch

A D T

Data: 6

Date: 08-10-2018

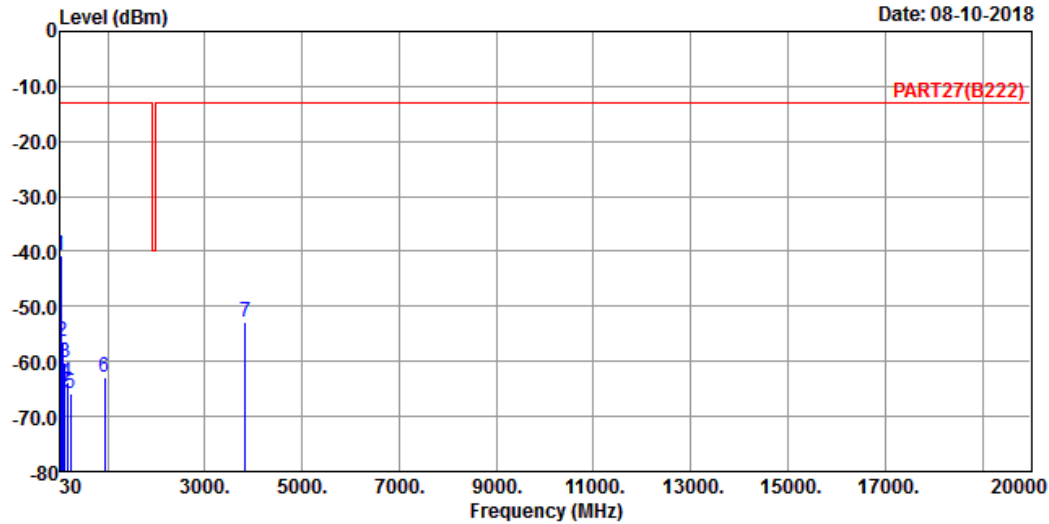

Site : 966 Chamber 5
 Condition: PART27(B222) VERTICAL
 Remak : NB-IOT Band 222 Stand-alone_Link_H-Ch
 Tested by: Thomas Wei

	Freq	Level	Read Level	Limit Line	Over Limit	Factor	Remark
	MHz	dBm	dBm	dBm	dB	dB	
1 pp	41.64	-40.73	-40.32	-13.00	-27.73	-0.41	Peak
2	68.80	-56.45	-48.13	-13.00	-43.45	-8.32	Peak
3	111.48	-60.23	-49.99	-13.00	-47.23	-10.24	Peak
4	171.62	-63.78	-57.91	-13.00	-50.78	-5.87	Peak
5	234.67	-65.93	-59.31	-13.00	-52.93	-6.62	Peak
6	943.74	-62.79	-64.44	-13.00	-49.79	1.65	Peak
7	3839.80	-52.95	-46.61	-13.00	-39.95	-6.34	Peak

5 Pictures of Test Arrangements

Please refer to the attached file (Test Setup Photo).

Appendix – Information on the Testing Laboratories

We, Bureau Veritas Consumer Products Services (H.K.) Ltd., Taoyuan Branch, were founded in 1988 to provide our best service in EMC, Radio, Telecom and Safety consultation. Our laboratories are FCC recognized accredited test firms and accredited according to ISO/IEC 17025.

If you have any comments, please feel free to contact us at the following:

Linko EMC/RF Lab

Tel: 886-2-26052180

Fax: 886-2-26051924

Hsin Chu EMC/RF/Telecom Lab

Tel: 886-3-6668565

Fax: 886-3-6668323

Hwa Ya EMC/RF/Safety

Tel: 886-3-3183232

Fax: 886-3-3270892

Email: service.adt@tw.bureauveritas.com

Web Site: www.bureauveritas-adt.com

The address and road map of all our labs can be found in our web site also.

--- END ---