



东莞市一佳电子通讯科技有限公司

Dongguan YiJia Electronics Communication Technology Co.,Ltd.

规格承认书

SPECIFICATION FOR APPROVAL

日期
Date 2023/11/28

编号
File No 23112801

版本
Revision 1.0

客户
CUSTOMER:

成都万创

客户料号

CUSTOMER NO:

YAA003R142

品名

PART NAME:

2.4/5.8G Antenna

供方料号

SUPPLIER NO:

YJS01.042.011.102A

送样日期Date:

送样数量Q'TY:

客户确认CUSTOMER APPROVED BY

APPROVAL	CHIEF	SUPERVISOR

供方确认 SUPPLIER SIGNATURE

APPROVAL	CHECK	DESIGN
 ChenGuoqiang	XieLi	ChenXingyi

YJ-RD-F04-A



承认书项目表

NO	内容 (Contents)	页数 (Number of Page)	页码 (Page Code)
1	承认书封面 (Spec Cover)	1	1
2	承认书项目表 (Spec Item)	1	2
3	工程成品图 (Drawing)	1	3
4	天线规格 (Antenna Specification)	1	4
5	S参数测试 (S Parameter)	2	5 ~ 6
6	无源测试 (Passive Test)	3	7 ~ 9
7	方向图 (Radiation Pattern)	6	10 ~ 15
8	材质证明 (Material Certificate)	25	16 ~ 40
9	RoHS报告 (RoHS Test Report)	**	**
10	N/A	N/A	N/A
11	-	-	-
12	-	-	-
13	-	-	-

RoHS
Compatible

CUSTOMER	
PART NO	

REV.	DESCRIPTION	DATE
△	首次发行	2020.12.11

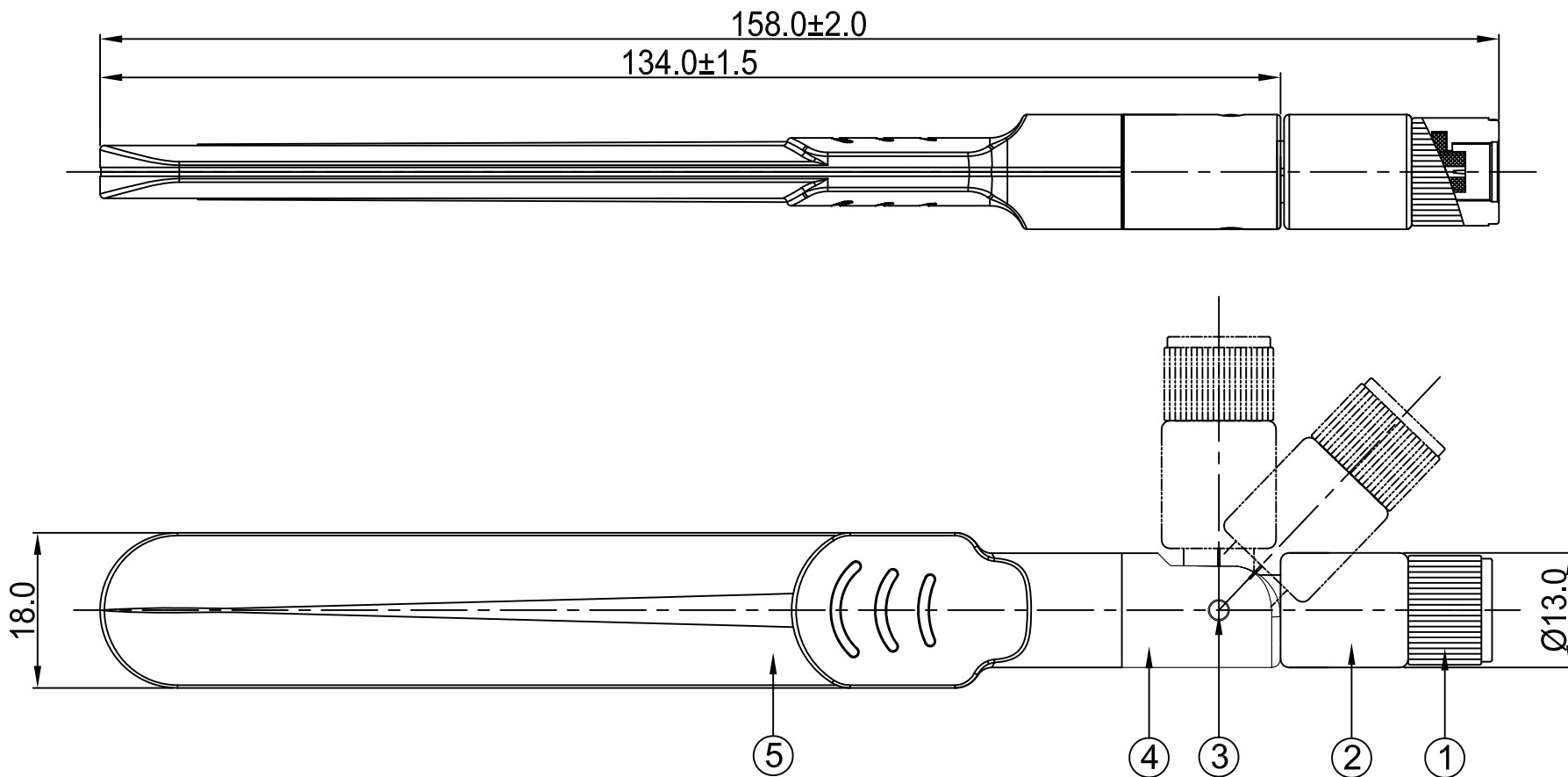

5	Antenna Cap	ABS, Color:Black	1
4	Upper Base	PC, Color:Black	1
3	Rivet	POM, Color:Black	2
2	Bottom Base	PC, Color:Black	1
1	SMA Male Reverse	Cu Black	1
NO	PART NAME	DESCRIPTION	Q.TY

东莞市一佳电子通讯科技有限公司
 Dongguan YiJia Electronics Communication Technology Co.,Ltd. Tel:0769-85535057 Fax:0769-81664308

PART NAME: 2.4/5.8G Antenna			
PART NO.: YJS01.042.011.102A		DATE: 2020.12.11	
APPROVED BY	CHECKED BY	DESIGNED BY	 Tolerance X.X ±0.50 X.XX±0.15 X° ±3°
殷涛	谢丽	吕森桦	
UNITS: mm SCALE: 1/1 REVISION: A			



天线规格

Antenna Specification

Electrical Properties

Frequency	2400-2484MHz 5720-5850MHz
Impedance	50 Ohm Nominal
V.S.W.R	2.0 Max
Gain	1.8 dBi@2400-2484MHz 3.5 dBi@5720-5850MHz
Radiation	Omni-directional
Polarization	Linear

Physical Properties

Connector	SMA Male Reverse
Cable Type	None
Cable Length	None
Cable Color	None
Operating Temp.	-40 ~ +85 °C
Storage Temp / Humidity	25 ± 5 °C / <70%



Antenna Performance Test

**Agilent
E5071B**

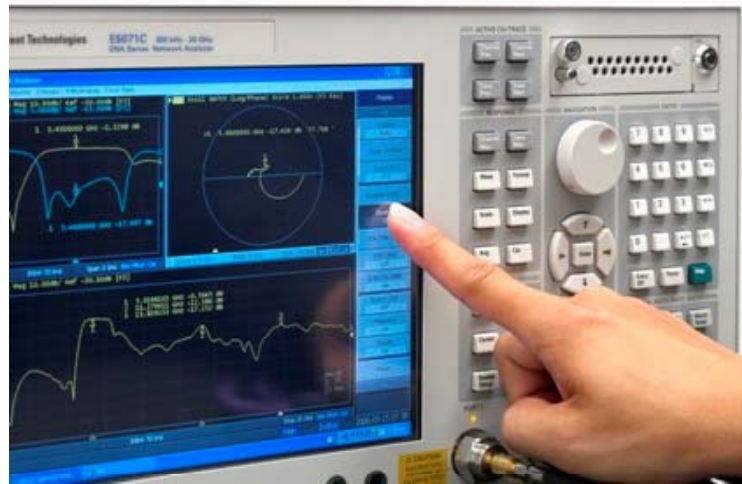

**SParameter
Test //
WIFI2.4G**

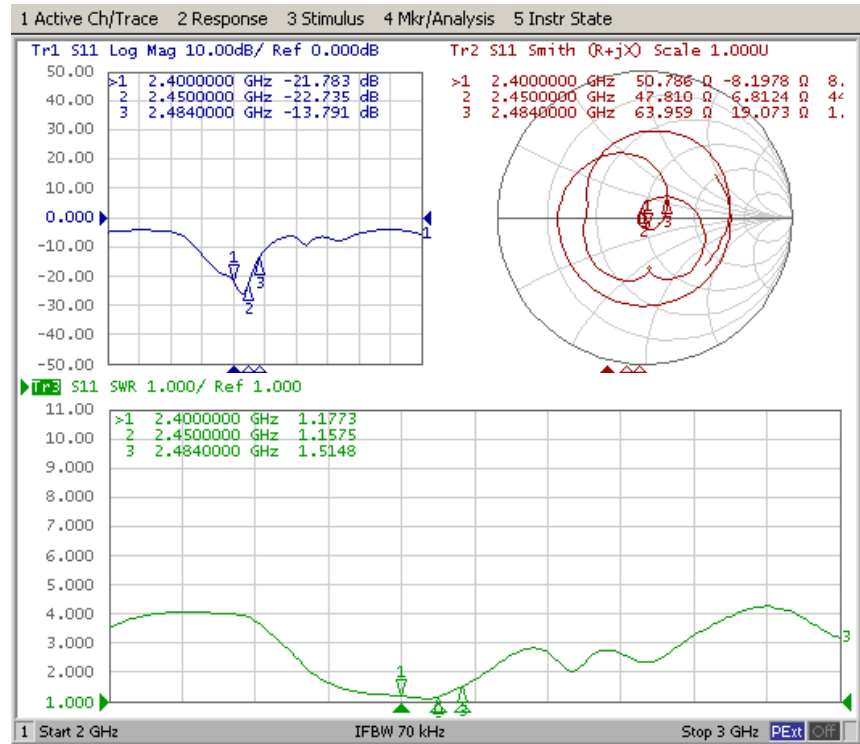



Antenna Performance Test

**Agilent
E5071B**

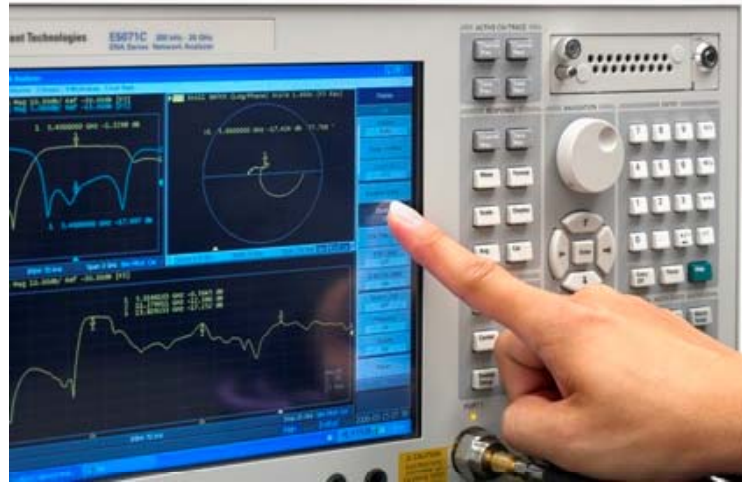

**S
Parameter
Test //
WIFI5.8G**

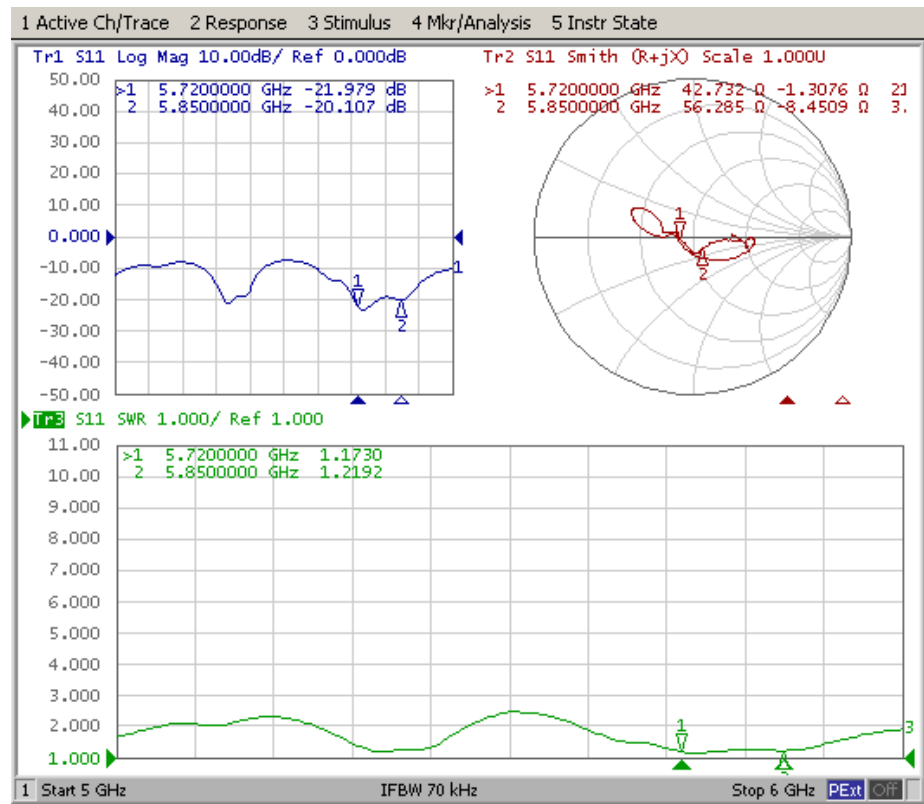



Antenna Passive Test





Passive Test For WIFI2.4G

Freq (MHz)	Effi (%)	Effi (dB)	Gain (dBi)
2400	51.5	-2.9	1.0
2410	52.9	-2.8	1.2
2420	53.1	-2.8	1.3
2430	53.8	-2.7	1.5
2440	54.2	-2.7	1.7
2450	54.6	-2.6	1.8
2460	53.8	-2.7	1.8
2470	53.7	-2.7	1.7
2480	53.1	-2.8	1.7
2490	52.2	-2.8	1.6
2500	49.9	-3.0	1.5



Passive Test For WIFI5.8G

Freq (MHz)	Effi (%)	Effi (dB)	Gain (dBi)
5700	41.7	-3.8	3.0
5720	41.3	-3.8	3.1
5740	44.5	-3.5	3.2
5760	46.5	-3.3	3.2
5780	43.2	-3.7	3.3
5800	53.7	-2.7	3.5
5820	53.5	-2.7	3.2
5840	51.7	-2.9	3.1
5860	54.5	-2.6	3.0
5880	55.4	-2.6	2.9
5900	62.1	-2.1	3.4



Radiation Pattern For WIFI Antenna(2400MHz)

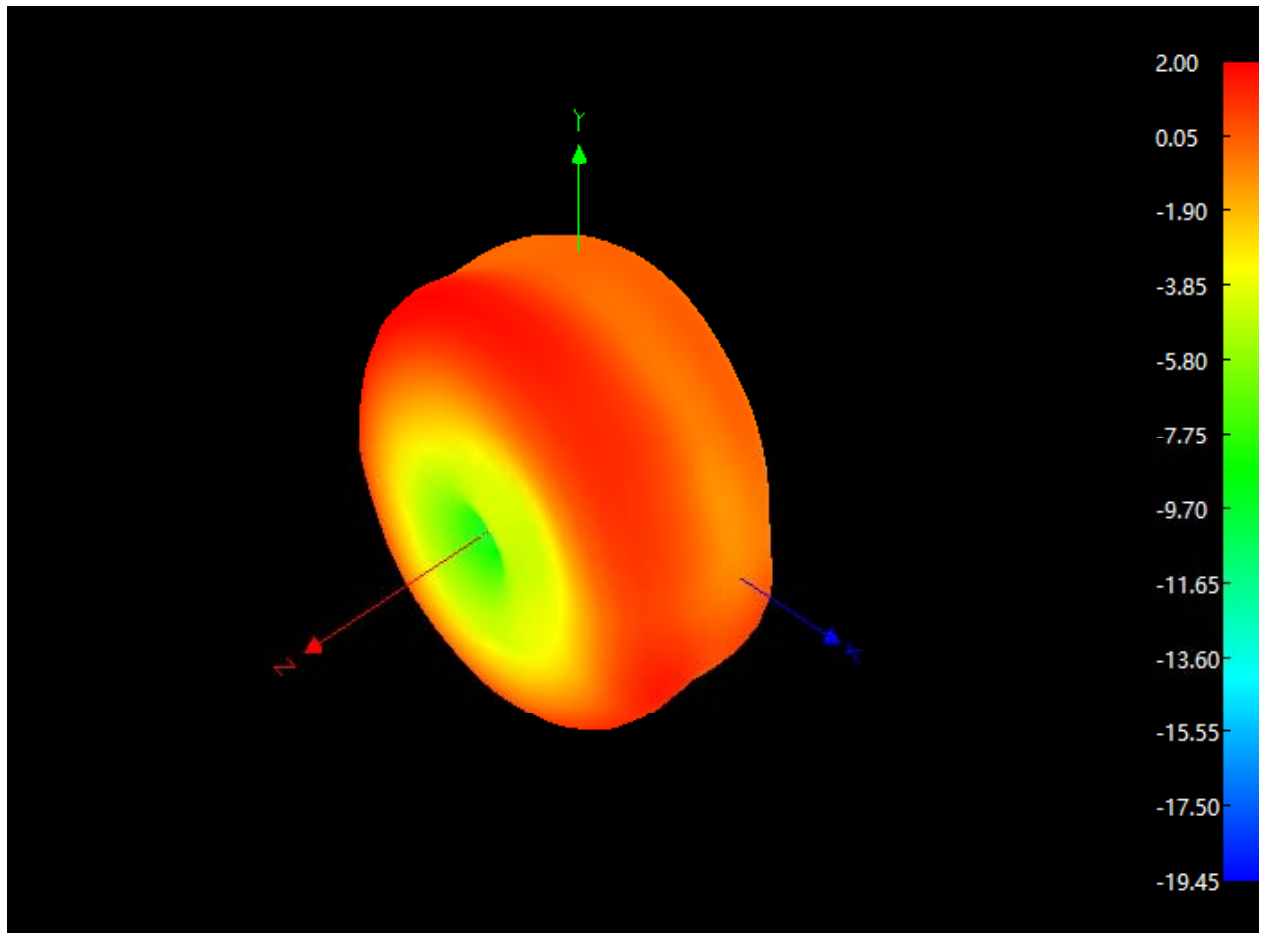



Radiation Pattern For WIFI Antenna(2450MHz)

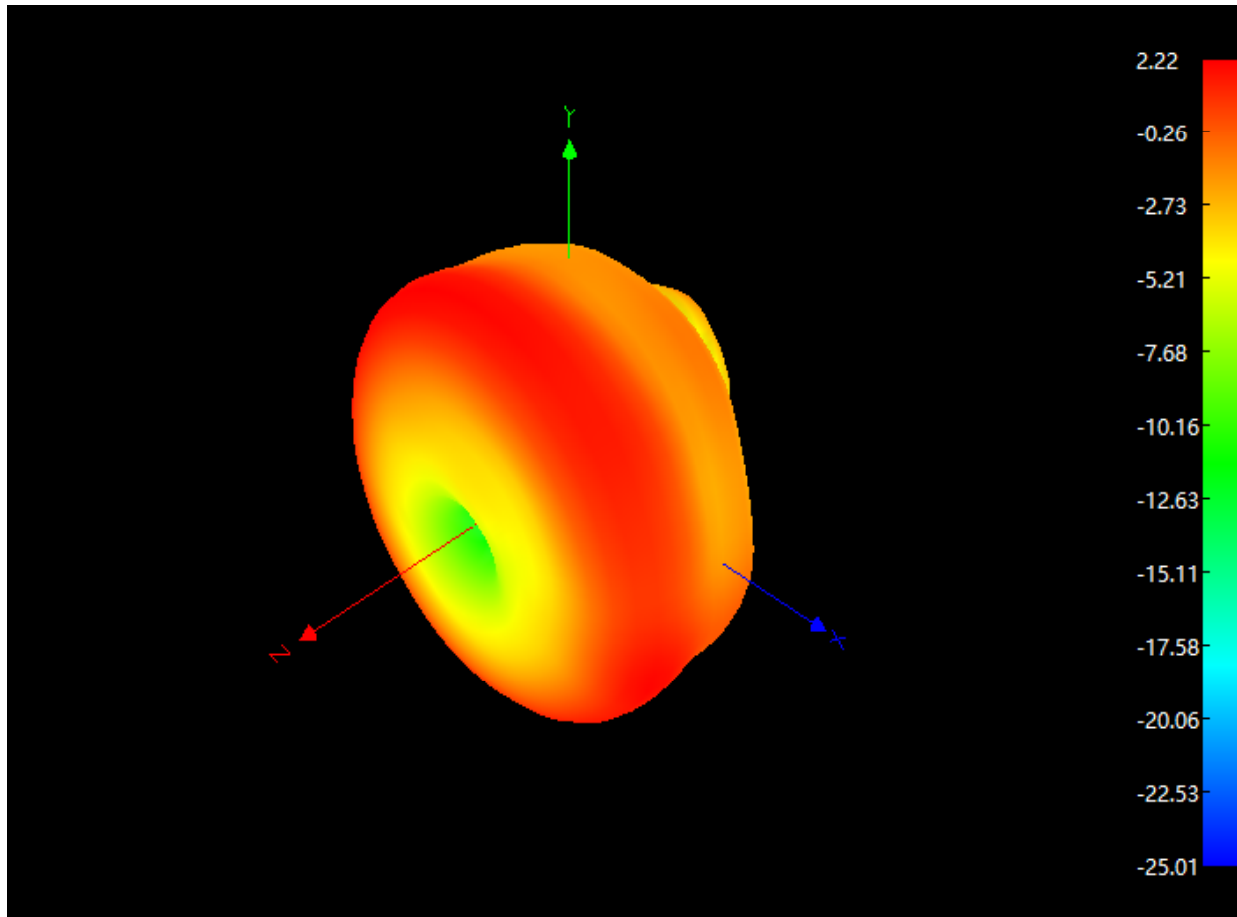



Radiation Pattern For WIFI Antenna(2500MHz)

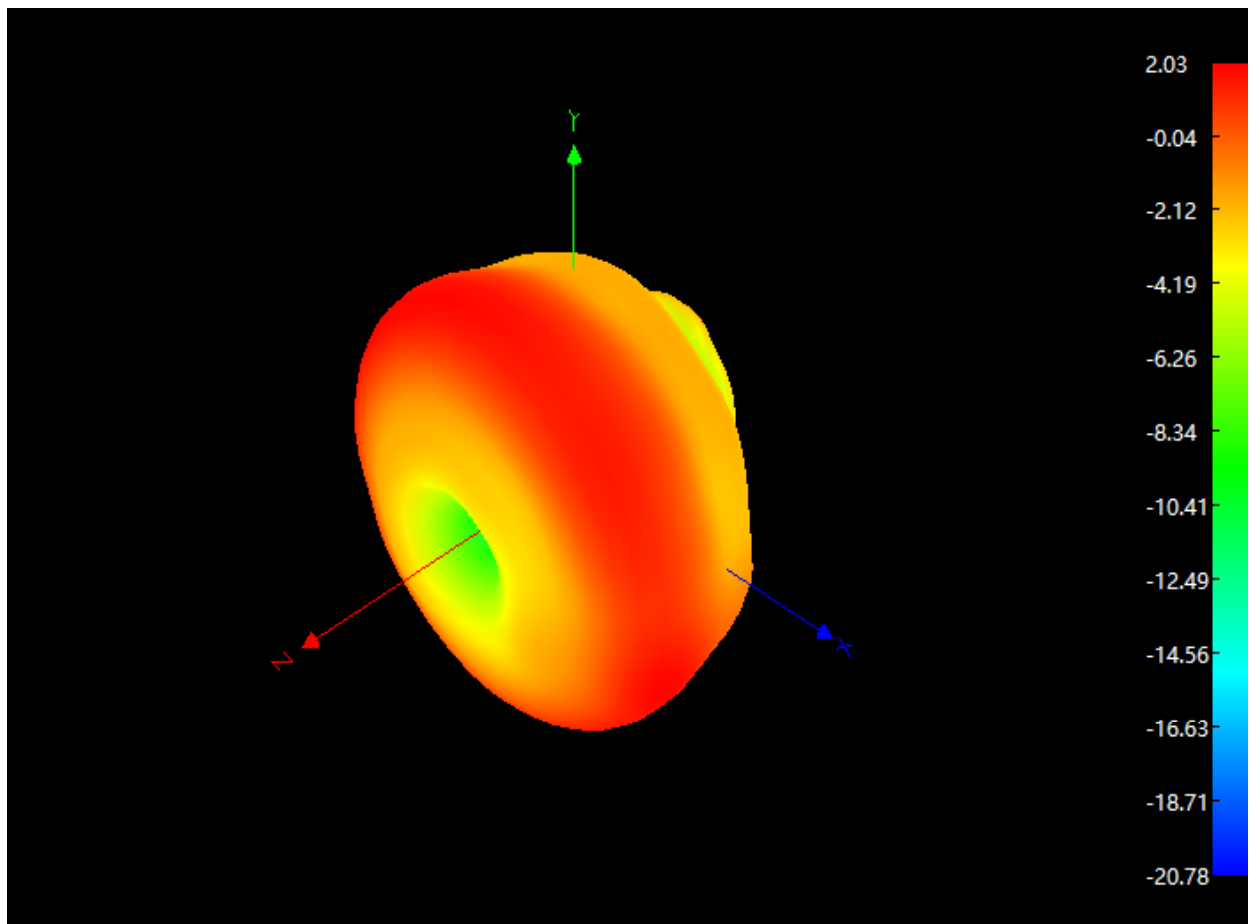



Radiation Pattern For WIFI Antenna(5150MHz)

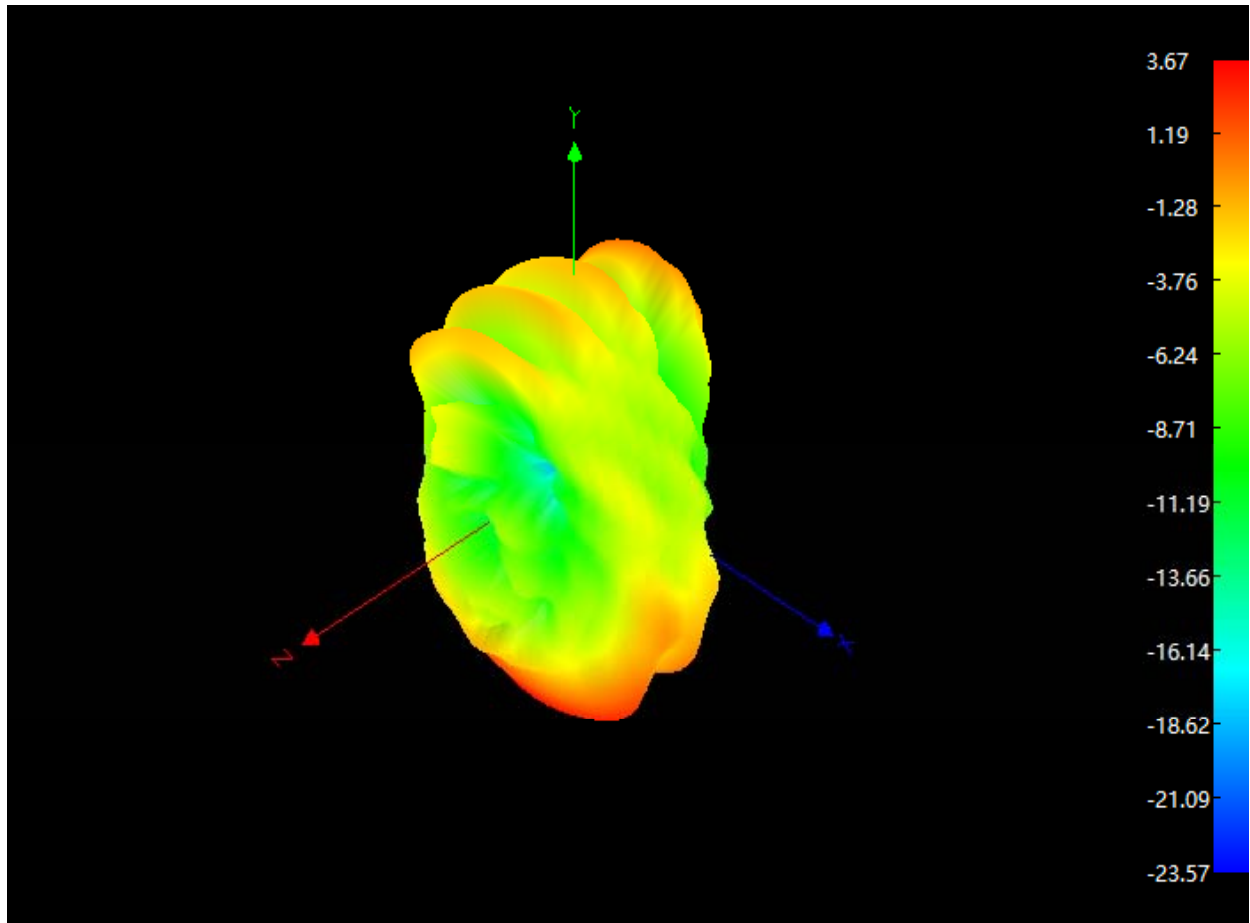



Radiation Pattern For WIFI Antenna(5500MHz)

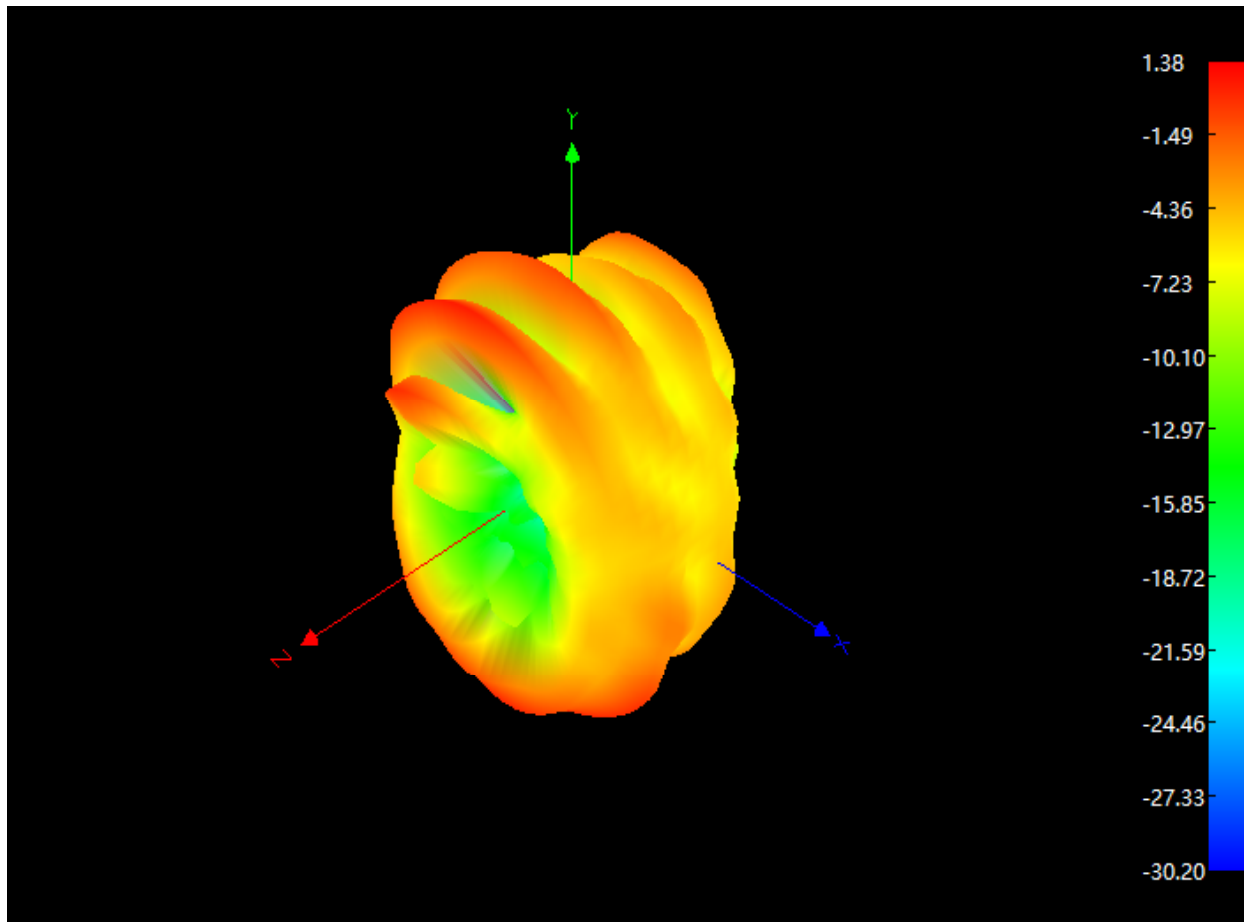



Radiation Pattern For WIFI Antenna(5850MHz)

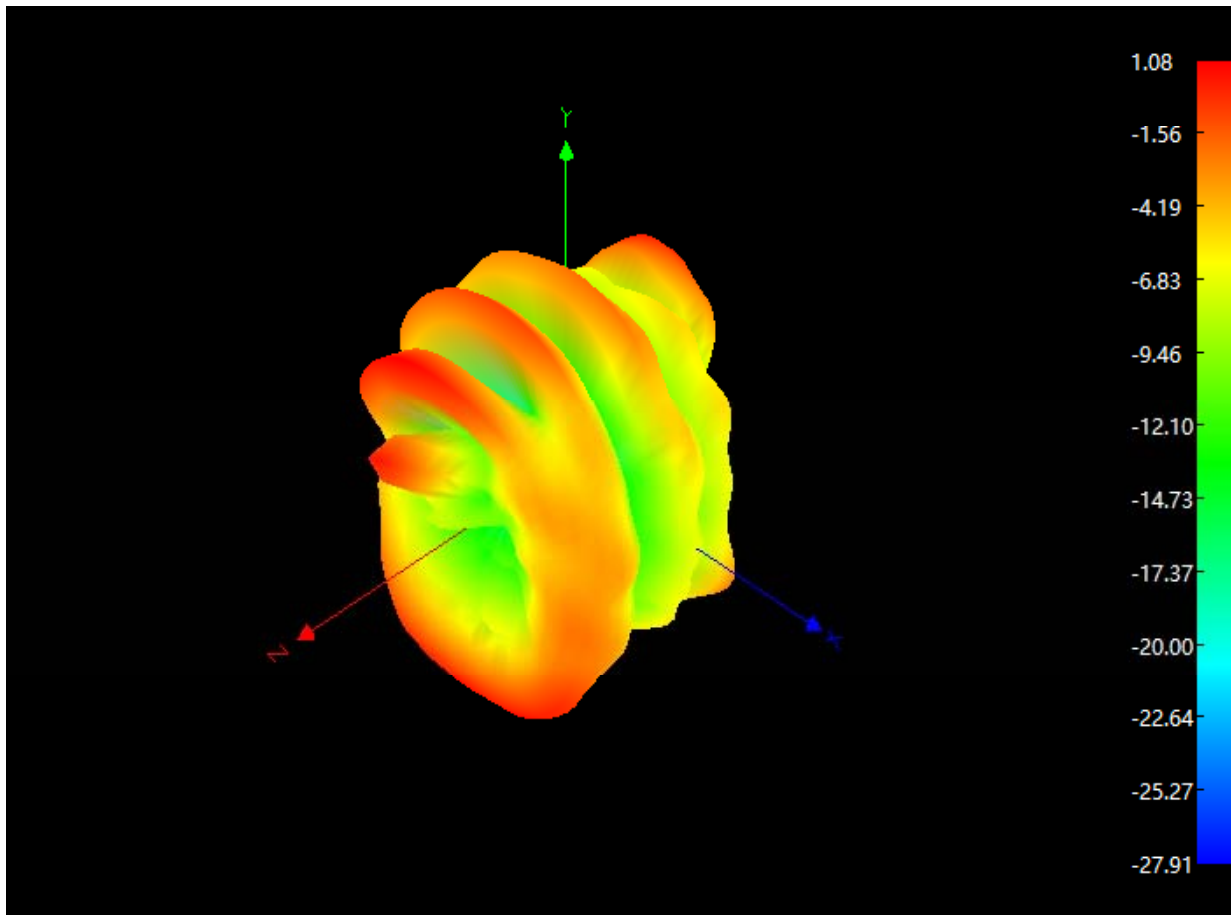

Product name: **POLYLAC® ABS**

Version 5

Section 1. Identification of the substance/ mixture and of the company/ undertaking

1.1 Product identifier

Product name: **POLYLAC® ABS**

This safety data sheet pertains to the following products:
PA-777D

1.2 Relevant identified uses of the substance or mixture and uses advised against

Relevant identified uses: Mixture used for the production of molded plastic articles

1.3 Details of the supplier of the Safety Data Sheet

Supplier: CHIMEI Corporation
Address: No. 398, Sec. 1, Zhongzheng Rd., Rende Dist., Tainan City, 717010, Taiwan
Telephone: +886 6 2663000 Ext. 1347

1.4 Emergency telephone number

Emergency telephone : +886 6 2663000 Ext. 2501

Section 2. Hazards identification

2.1 Classification of the substance or mixture

Classification according to Directive 67/548/EEC or 1999/45/EC: Not classified as hazardous (polymeric state)

Classification according to Regulation (EC) N° 1272/2008 (CLP): Not classified as hazardous (polymeric state)

2.2 Label elements

Not labelled as hazardous

2.3 Other hazards

vPvB/PBT assessment: not available

Section 3. Composition/information on ingredients

3.1 Composition of the substance/ preparation

Substance or Preparation Substance
Content

CAS	Name	content
9003-56-9	Acrylonitrile-Butadiene-Styrene Copolymer	>84%
9010-96-2	α-methylstyrene copolymer	<7%
31621-07-5	N-Phenylmaleimide copolymer	<7%
-	Additives	≤2%

Impurities Contributing to Hazard None

3.2 Additional information:

Product name: **POLYLAC ® ABS**

Version 5

Preparation does not contain dangerous substances above limits that need to be mentioned in this section according to applicable legislation.

Reach Info:

-	Registration No.
Acrylonitrile	01-2119474195-34-0045
Styrene	01-2119457861-32-0006 01-2119457861-32-0007 01-2119457861-32-0057 01-2119457861-32-0065 01-2119457861-32-0081
Buta-1,3-diene	01-2119471988-16-0044
N-phenylmaleimide	—

Section 4. First-aid measures

4.1 Description of first aid measures

General notes: Remove affected persons from the danger area, at the same time ensuring your own safety. Remove all contaminated clothing immediately

Following inhalation: In case of gases evolving from melted resin, move subject to fresh air. Treat symptomatically

Following skin contact: In case of pellets or powder, wash with water. In case of smelt, wash affected skin area and clothing with plenty of (soap and) water. Seek medical advice

Following eye contact: In case of pellets or powder, flush with plenty of water for at least 15 minutes. Seek medical advice if any dust particles still remain.

In case of gases evolving from melted resin of high temperature, flush with plenty of water for at least 15 minutes. Seek medical advice if necessary

Following ingestion: Induce vomiting. Rinse mouth with water. Seek medical advice if necessary

4.2 Most important symptoms & effects both acute & delayed

Aside from the information found under Description of first aid measures (above) and Indication of immediate medical attention and special treatment needed (below), any additional important symptoms and effects are described in Section 11: Toxicology Information.

4.3 Indication of any immediate medical attention and special treatment needed: -

If burn is present, treat as any thermal burn, after decontamination. If lavage is performed, suggest endotracheal and/or esophageal control. Danger from lung aspiration must be weighed against toxicity when considering emptying the stomach. No specific antidote. Treatment of exposure should be directed at the control of symptoms and the clinical condition of the patient.

Section 5. Fire-fighting measures

Product name: **POLYLAC ® ABS**

Version 5

Revision Date: March 15, 2023
Print Date: April 14, 2023

5.1 Extinguishing media

Suitable extinguishing agents: water spray, dry powder, foam, carbon dioxide
Dry chemical, carbon dioxide, regular foam extinguishing agent, spray

For safety reasons unsuitable extinguishing agents: High power water jet

5.2 Special hazards arising from the substance or mixture

During a fire, smoke may contain the original material in addition to combustion products of varying composition which may be toxic and/or irritating. Combustion products may include and are not limited to: Carbon dioxide. Carbon monoxide.

5.3 Advice for firefighters

Protective equipment: Wear positive-pressure self-contained breathing apparatus (SCBA) and protective fire fighting clothing (includes fire fighting helmet, coat, trousers, boots, and gloves). If protective equipment is not available or not used, fight fire from a protected location or safe distance.

Further measures: -

5.4 Additional information:

Hazchem-Code: -
Cool endangered containers with water jetspray.

Section 6. Accidental release measures

6.1 Personal precautions, protective equipment & emergency procedures

Pellets or powder remained on ground may cause slipping
Wear protective equipment
Ensure adequate ventilation
Keep away from ignition sources
Keep unprotected persons away

6.2 Environmental precautions

Gather pellets and powder thoroughly to avoid birds or fishes taking from draining water.
Do not allow product to reach sewage system or water bodies. Inform respective authorities in case product reaches water, sewage system or soil

6.3 Methods and material for containment and cleaning up

Avoid generation of dust. Remove all sources of ignition.
Collect dry and place in appropriate containers for disposal. Subsequent cleaning.
Particular danger of slipping when spread on the ground.

6.4 Reference to other sections

See Section 7 for information on safe handling. See Section 8 for information on personal protection equipment.

Section 7. Handling and storage

7.1 Precautions for safe handling

Product name: **POLYLAC ® ABS**

Version 5

Revision Date: March 15, 2023
Print Date: April 14, 2023

Protective measures: Provide adequate ventilation, and local exhaust as needed. Do not breathe dust. In the case of the formation of dust: Withdraw by suction. Molten material: Avoid contact with the substance.

Measures to prevent fire: Prevent from fire around handling area

Measures to prevent aerosol and dust generation: maintain good housekeeping standards to prevent accumulation of dust. To avoid dust explosion resulting from the existence of powder, electrostatics eliminators and grounding should be fixed to such equipment as air transferring pipes, bag filters and hoppers. Use electrically conductive filters for bag filters.

Measures to protect the environment: -

Advice on general occupational hygiene: -

7.2 Conditions for safe storage, including any incompatibilities

Technical measures and storage conditions: Keep the material at a cool dry place. Protect from direct sunlight, rain and violent temperature fluctuation. Fire is inhibited around storage area.

Requirements for storage rooms and vessels: Store in a well-ventilated place. Keep container tightly closed. Protect against heat /sun rays.

Suitable materials and coating: -

Unsuitable materials or coatings: -

Further information on storage conditions: -

7.3 Specific end use(s)

Recommendations: See the recommended processing condition and technical data sheet on this product for further information.

Section 8. Exposure controls/personal protection

8.1 Control parameters

Exposure Limits: Although some of the additives used in this product may have exposure guidelines, these additives are encapsulated in the product and no exposure would be expected under normal handling conditions.

8.2 Exposure control

Appropriate engineering controls: Install eyes washer and shower in the place of operation. Provide local exhaust ventilation system. Ensure compliance with applicable exposure limits

Personal protection:

- Respiratory protection: Wear masks for cleaning molding machines
- Hand protection: Heat-insulating gloves when handling molten form
- Eye protection: Wear safety glasses for general purpose. Wear chemical goggles for cleaning molding machines
- Skin and body protection: Gloves necessary for handling melted resin
- Hygiene measures: Wash hands after handling

Product name: **POLYLAC ® ABS**

Version 5

8.3 Environmental exposure controls

Product related measures to prevent exposure: None specific
Instruction measures to prevent exposure: None specific
Organizational measures to prevent exposure: None specific
Technical measures to prevent exposure: None specific
Environmental exposure controls: Do not allow product to reach sewage system or water bodies

Section 9. Physical and chemical properties

9.1 Information on basic physical and chemical properties

Appearance	Physical state: solid, granulate
Odour	Odourless or negligible
Colour	Natural or whitish
Odour threshold	No data available
pH	Not applicable
Melting point / freezing point	Not applicable
Initial boiling point and boiling range	Not applicable
Flash point	>400°C
Evaporation rate	Not applicable
Flammability (solid, gas)	Not applicable
Upper/lower flammability or explosive limits	Not applicable
Vapour pressure	Not applicable
Vapour density	Not applicable
Relative density (H ₂ O=1)	1.08~1.15 g/cm ³
Bulk density	Not available
Solubility(ies)	Not soluble
Partition coefficient (n-octanol/water)	Not available
Auto-ignition temperature	>400 °C
Decomposition temperature	>300 °C
Viscosity	Not applicable
Explosive properties	Not explosive
Oxidizing properties	Not oxidizing

9.2 Other safety information: -

Section 10. Stability and reactivity

10.1 Reactivity: Non-reactive under normal handling and storage conditions

10.2 Chemical stability: Stable under normal handling and storage conditions

10.3 Possible hazardous reaction: Polymerization will not occur.

10.4 Conditions to avoid: Avoid temperatures above 300 °C. Exposure to elevated temperatures can cause product to decompose.

10.5 Incompatible materials: Strong oxidizing agents, Gasoline, aldehydes, ketone

10.6 Hazardous decomposition products: Decomposition products depend upon temperature, air supply and the presence of other materials. Processing may release fumes and other decomposition products. At temperatures exceeding melt temperatures, polymer fragments can be released. Fumes can be irritating. Decomposition products can include and are not limited to: Combustible gases. In case of fire may be liberated: smoke, Styrene-Monomer, aldehydes and acids (organic), carbon monoxide and carbon dioxide (CO₂).

Product name: **POLYLAC ® ABS**

Version 5

Revision Date: March 15, 2023
Print Date: April 14, 2023

Section 11. Toxicological information

11.1 Information on toxicological effects

Toxicological effects:

- Acute toxicity (oral): Based on available data, the classification criteria are not met. Mild acute toxicity
- Acute toxicity (dermal): Based on available data, the classification criteria are not met. Mild acute toxicity
- Acute toxicity (inhalative): Based on available data, the classification criteria are not met. Mild acute toxicity
- Skin corrosion/irritation: Lack of data.
- Eye damage/irritation: Lack of data.
- Sensitisation to the respiratory tract: Lack of data. The chemical structure does not suggest a specific alert for such an effect.
- Skin sensitisation: Based on available data, the classification criteria are not met. Not sensitizing
- Germ cell mutagenicity/Genotoxicity: Lack of data. The chemical structure does not suggest a specific alert for such an effect.
- Carcinogenicity: Based on available data, the classification criteria are not met.
- Reproductive toxicity: Lack of data. The chemical structure does not suggest a specific alert for such an effect.
- Effects on or via lactation: Lack of data.
- Specific target organ toxicity (single exposure): Lack of data.
- Dusts: Can cause skin, eye and respiratory tract irritation.
- Specific target organ toxicity (repeated exposure): Lack of data.
- Processing, thermal hazards: Vapours: Can cause skin, eye and respiratory tract irritation.

Symptoms

- Dust: Can cause skin, eye and respiratory tract irritation.
- The melted product can cause severe burns.
- Irritating to eyes, respiratory system and skin.
- In case of ingestion: Swallowing may cause gastrointestinal irritation and pain of guts.

Section 12. Ecological information

12.1 Toxicity

Not expected to be acutely toxic, but material in pellet or bead form may mechanically cause adverse effects if ingested by waterfowl or aquatic life.

12.2 Persistence and degradability

Further details:

- Biodegradation: Product is not readily biodegradable.
- Degradation at UV-radiation/sunlight
- Environmental half-life period: ≥ 100 days (estimated)
- The product is likely to persist in the environment.

Effects in sewage plants:

- In sewage treatment plants it may be separated mechanically.

12.3 Bioaccumulative potential

To avoid bioaccumulation plastics should not be disposed in the sea or in other water environments.

12.4 Mobility in soil

In the terrestrial environment, material is expected to remain in the soil., In the aquatic environment, material will sink and remain in the sediment.

Product name: **POLYLAC ® ABS**

Version 5

Revision Date: March 15, 2023
Print Date: April 14, 2023

12.5 Results PBT & vPvB assessment

This mixture has not been assessed for persistence, bioaccumulation and toxicity (PBT).

12.6 Other adverse effects:

General information: Do not allow to enter into ground-water, surface water or drains.

12.7 Additional information: -

Section 13. Disposal considerations

13.1 Waste treatment methods

Product / Packaging disposal: Dispose in accordance with the current local regulations.

Waste codes according to European Waste Catalogue: -

Waste treatment-relevant information: Inadequate incineration may generate toxic gases such as CO, HCN, AN and SM

Sewage disposal-relevant information: -

Other disposal recommendations: -

Section 14. Transport information

ADR/RID

14.1 UN number

Not applicable

14.2 UN proper shipping name

Proper Shipping Name: NOT REGULATED

14.3 Transport hazard class(es)

Not applicable

14.4 Packing Group

Not applicable

14.5 Environmental hazards

Not considered environmentally hazardous based on available data

14.6 Special precautions for user

Special Provisions: no data available

Hazard identification No: no data available

ADNR / ADN

14.1 UN number

Not applicable

14.2 UN proper shipping name

Proper Shipping Name: NOT REGULATED

14.3 Transport hazard class(es)

Not applicable

14.4 Packing Group

Not applicable

14.5 Environmental hazards

Not considered environmentally hazardous based on available data

14.6 Special precautions for user

no data available

IMDG

Product name: **POLYLAC ® ABS**

Version 5

14.1 UN number

Not applicable

14.2 UN proper shipping name

Proper Shipping Name: NOT REGULATED

14.3 Transport hazard class(es)

Not applicable

14.4 Packing Group

Not applicable

14.5 Environmental hazards

Not considered environmentally hazardous based on available data

14.6 Special precautions for user

EMS Number: Not applicable

14.7 Transport in bulk according to Annex II of MARPOL 73/78 and the IBC Code

Not applicable

ICAO/IATA

14.1 UN number

Not applicable

14.2 UN proper shipping name

Proper Shipping Name: NOT REGULATED

14.3 Transport hazard class(es)

Not applicable

14.4 Packing Group

Not applicable

14.5 Environmental hazards

Not considered environmentally hazardous based on available data

14.6 Special precautions for user

no data available

Section 15. Regulatory information

15.1 Safety, health and environmental regulations /legislation specific for the substance or mixture

Authorization and / or restrictions on use: None

15.2 Chemical Safety Assessment

For this substance a chemical safety assessment is not yet required.

Section 16. Other information

16.1 Indication of changes

Version 1: First issue according to Regulations (EC) 1907/2006 (REACH) & 1272/2008 (CLP)

16.2 Abbreviations and acronyms

AGS	Ausschuss für Gefahrstoffe	LoW	List of Waste
AF	Assessment Factor	MARPOL	MARine POLLution
BCF	BioConcentration Factor	MIE	Minimum Ignition Energy
CAS	Chemical Abstract Service	N°EC	European Commission number

Product name: **POLYLAC ® ABS**

Version 5

CMR	Carcinogenic, Mutagenic and Reprotoxic	NFPA	National Fire Protection Association
CSR	Chemical Safety Report	NIOSH	National Institute of Occupational Safety and Health
DFG	German Research Foundation	NOEC	No Observed Effect Concentration
DNEL	Derived No Effect Level	NOELR	No Observed Effect Loading Rate
EC	European Commission	OECD	Organisation for Economic Co-operation and Development
EC50	Effective Concentration (required to induce a 50% effect)	OEL	Occupational Exposure Limit
EEC	European Economic Community	OSHA	Occupational Safety and Health Administration
EWC	European Waste Catalogue Code	PBT	Persistent Bioaccumulable Toxique
IDLH	Immediately Dangerous to Life or Health	PNEC	Previsible Non Effect Concentration
IBC	International Bulk Chemical	QSAR	Quantitative Structure-Activity Relationship
Koc	Soil/Water Partition Coefficient	STOT	Specific Target Organ Toxicity
Kow	Octanol/Water Partition Coefficient	TCLo	Toxic Concentration Low
LC50	Lethal Concentration 50	TDLo	Toxic Dose Low
LD50	Lethal Dose 50	UN	United Nations
LEL	Lower Explosive Limit	UVCB	Unknown or Variable Composition Complex Reaction Products, or Biological Materials
LL100	Lethal Loading	vPvB	very Persistent, very Bioaccumulative
LOEC	Lowest Observed Effect Concentration		

16.3 Key literature references and sources for data

<http://esis.jrc.ec.europa.eu/>
<http://echa.europa.eu/>
<http://gestis-en.itrust.de>

16.4 Training advice: -

16.5 Further information: According to the guidance version 2.0 for monomers and polymers from the European Chemicals Agency dated as of April 2012, the classification of the polymer takes into account the classification of all its constituents, such as unreacted monomers. These constituents in fact should be taken into account for classification of the polymer. This means that the same classification methods as for mixture should be applied to polymer substances.

In order to determine a classification for the studies about the water soluble fraction as well as the absorption should be performed on the polymer as such.

To the best of our knowledge and belief, the information contained herein is accurate and obtained from sources believed to be reliable. No representation is made that the information is complete or the material is suitable for all purposes. The final determination as to the suitability of the user's intended use of the material is the sole responsibility of the user. All materials may present unknown hazards even when used in common applications and accordingly, it is the sole responsibility of the user to understand and address all potential hazards, including those identified herein. The information set forth in Sections 11 and 12 reflects data available as of the date hereof. It is anticipated that such data will be updated.

SAFETY DATA SHEET(SDS)

Issued: September 26 ,
2012

Revised: January 7 , 2014

FileNo. 1001

1. Chemical Product & Company Identification

CHEMICALPRODUCT NAME: DURACON® M90-44 CF2001
NAME OF COMPANY: Polyplastics Co.,Ltd.
SECTION IN CHARGE: 2-18-1 Konan, Minato-ku, Tokyo,108-8280 Japan
ADDRESS: Quality Assurance Dept.
TELEPHONE NUMBER: 03-6711-8605
FACSIMILE NUMBER 03-6711-8616

2. Hazards identification

[GHS CLASSIFICATION]

Physical and Chemical Hazards : ·Flammable solids : Classification not possible
·Self-reactive substances and mixtures : Not applicable
·Pyrophoric solids : Not classified
·Self-heating substances and mixtures : Not classified
·Substances and mixtures, which in contact with water, emit flammable gases : Not classified
·Oxidizing solids : Not classified
·Corrosive to metal : Not classified

Health Hazards : Carcinogeneses : No hazard
Specific target organ/systemic toxicity (Repeated exposure) : No hazard

[GHS CLASSIFICATION]

Environmental Hazards : No hazard

[SYMBOL] : None

[SIGNAL WORD] : None

[HAZARD STATEMENT] : None

[PRECAUTIONARY STATEMENTS]

Prevention : ·Wash hands thoroughly after handling.
·Wear protective gloves.

Response : -

Storage : Avoid direct sunlight and store in a well-ventilated place.

Disposal : Dispose of contents/container in accordance with local & national regulations.

3. Composition/information on ingredients

SUBSTANCE/PREPARATION : Substance
COMMON CHEMICAL NAME : Polyoxymethylene
SYNONYMS : Polyacetal(POM)
INGREDIENTS AND COMPOSITION : POM \geq 99%, Others \leq 1%
CHEMICAL FORMULA : $\text{--}[(\text{CH}_2\text{-O})_p / (\text{CH}_2\text{CH}_2\text{O})_q]\text{n}$
SERIAL No. IN OFFICIAL GAZETTE : 7-129(base resin)
(Law Concerning Examination and Regulation of Manufacture, etc., of Chemical Substances)
CAS No. : 24969-26-4(base resin)
INGREDIENTS CONTRIBUTING TO THE HAZARD : Formaldehyde.
Cadmium, lead, hexavalent chromium and mercury are not used in this grade.

4. First-aid measures

INGESTION : When a gas generated from the molten polymer has been inhaled, move to area of fresh air without delay and wait until the victim is recovered. If sick feeling continues, ask a physician for advice.

SKIN CONTACT	:	Cool the contacted skin with clean water without delay, if a contact with the polymer in a molten form. Do not force to remove the solid resin on the skin. If any burns are observed on the skin, ask a physician for advice.
EYE CONTACT	:	Cool and rinse the eye with clean water for at least 15 minutes when the eyes had contact with molten polymer. In case of wearing contact lenses, remove the lenses as soon as possible, and ask a physician for advice. When the eye had contact with the polymer in an ordinary solid form, rinse the eye with clean water without delay. If the discomfort persists, ask a physician for advice.
SWALLOW	:	Help to vomit as much as possible. If sick feeling continues, and ask a physician for advice.
<hr/>		
5. Fire-fighting measures		
EXTINGUISHING MEDIA	:	Water, foam fire-extinguishing agent, powder fire-extinguishing agent, and carbon dioxide gas.
SPECIFIC METHODS	:	Extinguish the fire with water. A method of extinguishing an ordinary fire may be applied. Do not apply water directly to processing machines.
SPECIFIC HAZARDS	:	Incomplete combustion leads to generation of toxic gases such as carbon monoxide or formaldehyde, in addition to carbonic acid gas and water.
SPECIAL PROTECTIVE EQUIPMENT FOR FIREFIGHTERS	:	In case the fire gained force, use a gas mask or other protective equipment.
<hr/>		
6. Accidental release measures		
PERSONAL PRECAUTIONS	:	When pellets were spilled on the road or floor, wipe them off with a besom or cleaner not to cause slipping.
ENVIRONMENTAL PRECAUTION	:	Handle the spillage in accordance with provisions given in the "Resin pellet spillage preventive manual", in order to prevent intakes by marine animals and birds.
<hr/>		
7. Handling and storage		
HANDLING	:	Polyacetal resin in a pellet form will neither ignite nor explode at room temperatures, but it falls under the inflammables designated by the Fire Service Law. Keep it away from the igniting sources, as it quickly gains force once it is ignited.
HANDLING 2	:	Polyacetal resin in a powdered form is likely to cause dust explosion and is therefore designated in the Guideline for Hazard of Dust Explosion in U.S.Bureau of Mines. Effective earthing means or use of inert gas like N2 are required for dust handling equipment to eliminate static electricity.
HANDLING 3	:	This pellets spilled on the floor are likely to cause slipping. Remove such spillage at any times.
HANDLING 4	:	For molding work, effective means for local exhaust are required to discharge gases generated by melt processing.
HANDLING 5	:	Avoid inhaling of gases generated in molding work. Do not directly touch resin of high temperature.
HANDLING 6	:	Avoid retaining hot resin in the processing machines for many hours.
HANDLING 7	:	Avoid mixed extrusion with strong acid, oxidizing agents and PVC.
STORAGE	:	Keep the substance away from any fire or heat sources for the sake of safe storage.
STORAGE 2	:	This polymer is a synthetic resin designated as an inflammable substance by the Fire Service Law and should be handled in accordance with municipal rules and regulations (concerning fire-fighting equipment, indoor storage, for instance).

RECOMMENDED PACKAGING MATERIALS	:	No information.
---------------------------------	---	-----------------

8. Exposure controls/ personal protection		
CONTROL CONCENTRATION	:	None at present
PERMISSIBLE CONCENTRATION	:	OSHA PEL/1985 Max. permissible concentration of inactive powder 15mg/m ³ – ditto – (Aspiration) 5mg/m ³ ACGIH TLV/1992 1993 Exposure limit of the powder TWA 10 mg/m ³ (Reference) Human exposure to formaldehyde – Ministry of Health & Welfare/2002 Guideline value 0.08 ppm OSHA Parameter/1992 TWA 0.75 ppm STEL 2 ppm ACGIH TLV/1992 1993 TWA 0.3 ppm
ENGINEERING MEASURE	:	·When handling dust: Use totally enclosed containers resisting dust explosion. ·When heat melted in molding: Effective local ventilation must be provided.
PERSONAL PROTECTIVE EQUIPMENT		
RESPIRATORY PROTECTION	:	Wear a dust-proof mask.
HAND PROTECTION	:	Wear heat-resisting gloves against burns, when handling molten polymer.
EYE PROTECTION	:	Wear protective glasses or goggles.
SKIN & BODY PROTECTION	:	Wear long sleeve clothes against burns, when handling molten polymer.

9. Physical and chemical properties		
APPEARANCE etc.	:	Pellet
BOILING POINT	:	Not applicable
VAPOUR PRESSURE	:	Not applicable
VOLATILITY	:	Not applicable
INITIAL BOILING POINT	:	Not applicable
SUBLIMATION	:	None
MELTING POINT	:	165°C
DENSITY	:	1.41
SOLUBILITY	:	Insoluble in water
FLASH POINT	:	320°C or higher
IGNITION POINT	:	400°C or higher
EXPLOSION PROPERTY	:	Not applicable
INFLAMMABILITY	:	Inflammable(Designated as inflammable resin by the Fire Service Law)
REACTIVITY WITH WATER	:	None
OXIDIZABILITY	:	None
SELF-REACTIVITY	:	None
DUST EXPLOSIVENESS	:	Upper explosion limit : Not applicable. Lower explosion limit : 35g/m ³

10. Stability and reactivity		
STABILITY AND REACTIVITY CONDITIONS TO AVOID	:	Stable for normal storage or handling. Avoid contacts with strong acid, oxidizing agent or PVC under hot melt conditions.
HAZARDOUS DECOMPOSITION PRODUCTS	:	Formaldehyde will be generated when heated (for drying or melting) or burnt.

11. Toxicological information		
-------------------------------	--	--

SKIN CORROSION/IRRITATION	:	No finding.
SERIOUS EYE DAMAGE/IRRITATION	:	Gas generated in drying or melting is irritating eyes and skins.
RESPIRATORY OR SKIN SENSITISATION	:	No finding
ACUTE TOXICITY(INCLUDING LD50)	:	No finding.
SUBACUTE TOXICITY	:	No finding.
CHRONIC TOXICITY	:	No finding.
CARCINOGENECITY	:	No finding.
MUTAGENECITY(Micro organisms, chromosomal aberration)	:	No finding.
REPRODUCTIVE TOXICITY	:	No finding.
TERATOGENICITY	:	No finding.
OTHERS(Including generation of hazardous gases by reaction with water, for example)	:	No finding in this report means that there will be no hazard in general, but no proving data available at the time of reporting.
OTHER CAUTIONS	:	With regard to dust, the maximum permissible concentration and limits are fixed by OSHA and ACGIH.
OTHER CAUTIONS 2	:	Formaldehyde will be generated when heated (for drying or melting) or burnt.
OTHER CAUTIONS 3	:	Carcinogenicity class of formaldehyde, which may be generated if overheated. IARC(International Agency for Research on Cancer): Group1
<hr/>		
12. Ecological information		
BIODEGRADABILITY	:	No finding.
BIOACCUMULATION	:	No finding.
FISH TOXICITY	:	No finding.
HAZARDS TO OZONE LAYER	:	None
<hr/>		
13. Disposal considerations		
WASTE FROM RESIDUES	:	This is designated as waste plastics among industrial wastes by the Wastes Disposal Law. Disposal waste pellets through licensed wastes handlers or local autonomous bodies if they are handling wastes disposal.
WASTE FROM RESIDUES 2	:	When disposed by incineration, use the well controlled incinerators in accordance with the Wastes Disposal Law, Air Pollution Control Law and Water Pollution Prevention Law.
<hr/>		
14. Transport information		
UN CLASSIFICATION NUMBER	:	Not applicable
OTHER CAUTIONS	:	Handle with care so as not to give damages to containers or not to be subjected to wetting.
OTHER CAUTIONS 2	:	Secure the containers firmly so as not to cause collapsing.
<hr/>		
15. Regulatory information		
FIRE SERVICE LAW	:	Inflammable synthetic resin Designated quantity: More than 20m3 for the foamed product. More than 3,000 kg for other types.
WASTE DISPOSAL LAW	:	Waste plastics among industrial wastes.
OTHERS	:	Formaldehyde is designated as Class 2 substance by the Industrial Safety and Health Law(Regulations concerning hazards caused by specific chemicals) and designated as deleterious substance by the Poisons and Deleterious Substance Control Law. Recommended usage, criteria, and limit values are provided by Japan Industrial Safety and Health Society, OSHA and ACGIH.
<hr/>		
16. Other information		
HANDLING OF THE DETAILS GIVEN ABOVE	:	This SDS is the English version translated from the Japanese SDS which is prepared for domestic use.

Details given above are based on references, information and data available at this moment, but no warranty can be made on exactness of these details. They are also prepared on the assumption that the product will be handled in a normal way. For special handling, adequate safety and environmental measures should be taken in respect to its applications. Our products are not specifically intended for implants for medical and dental applications, and therefore they are not recommended for such applications.

"No finding" in this report means that there will be no hazard in general, but no proving data is available at the time of reporting.

WHERE TO CALL FOR FURTHER
INFORMATION

: Polyplastics Co., Ltd. Quality Assurance Dept.
Tel. No 03-6711-8605

*DURACON® is a registered trademark of Polyplastics Co., Ltd. in Japan and other countries.

General PC WONDERLITE® Characteristics PC-110

特性 PROPERTIES	測試方法 ASTM TEST METHOD	測試條件 TEST CONDITION	單位 UNIT	通用級 GENERAL
				PC-110
熔融指數 Melt Flow Index	D1238	300 °C, 1.2 Kg	g/10 min	10.0
比重 Mass Density	D792	23 °C	-	1.2
硬度 Hardness	D785	-	M Scale	77
拉伸強度 (屈服) Tensile Strength (Yield)	D638	6 mm/min	Kg/cm ²	630
			lb/in ²	8935
延伸率 Tensile Elongation	D638	6 mm/min	%	110
彎曲強度 Flexural Strength	D790	1.3 mm/min	Kg/cm ²	920
			lb/in ²	13030
彎曲彈性模數 Flexural Modulus	D790	1.3 mm/min	10 ⁴ Kg/cm ²	2.4
			10 ⁵ lb/in ²	3.4
IZOD 衝擊強度 Izod Impact Strength	D256 (Notched)	3.2 mm, 23°C	Kg-cm/cm	87
			ft-lb/in	15.9
維氏軟化溫度 Vicat Softening Temp.	D1525	1 Kg, 50 °C/hr	°C	150
熱變形溫度 Heat Distortion Temp.	D648 (annealed)	132°C × 8 hours Loading 4.6 kg/cm ²	°C	146
UL 燃燒等級 UL Flammability	UL 94	-	-	1.5 mm V-2

January 23, 2014

Notes : These are typical properties only and are not to be construed as specifications. Users should confirm results by their own tests.

The above statement is based on our current level of knowledge and covers the above products directly manufactured and supplied by CHI MEI CORPORATION at the date of issue. CHI MEI CORPORATION makes no warranties, whether express or implied, and assumes no liability in connection with any use of above information. Notwithstanding the foregoing, CHI MEI CORPORATION shall in no event be held obligated or liable for any claims due to or arising from (i) any customer provided, consigned, materials and/or parts, which are incorporated or adopted in the products; (ii) any combination of the products with material not provided or authorized by our company; (iii) any modifications to the products which are made or directed by customer; (iv) our compliance with the specifications, instructions, and/or designs provided by customer; (v) any anti-trust, unfair competition and/or other unlawful actions effected by customer; or (vi) any defects, infringement, breach and/or violation which are arising out of customer's faults or otherwise not solely and directly attributable to CHI MEI CORPORATION. In no event will CHI MEI CORPORATION be liable for any indirect, special, exemplary, punitive, or consequential damages (including lost profits) of any nature whatsoever whether arising out of the purchase, shipment, unloading, handling, or use of any product or otherwise.

物质安全资料表(MSDS)

一、物品与厂商资料

物品名称：酸金导电盐

制造商或供应商名称、地址：深圳鑫华昌表面处理技术有限公司

紧急联络电话/传真电话：0755-29106013/29106011

二、成份资料

纯物质：酸金导电盐

中文名称：酸金导电盐

化学文摘社登记号码：无

有害物质万分比：不含有

化学性质：强络合剂，媒染剂，有机酸盐类

三、危害辨识资料

最 重 要 危 害 效 应	健康危害效应：大量食入会引致呕吐，导致呼吸困难
	环境影响：大量外泄会引致水体COD值升高，
	物理性及化学性危害：对金属的强络合性
	特殊危害：无
物品危害分类：有害	

四、急救措施

不同暴露途径之急救方法
吸入：立即就医,清洗呼吸系统,转到清新空气的地方
皮肤接触：用水冲洗干净即可
眼睛接触：用大量水冲洗干净即可
食入：立即就医,清洗肠胃
最重要症状及危害效应：呕吐，咳嗽
对急救人员之防护：穿带防护口罩，目镜，手套，

五、灭火措施

适用灭火剂：干粉,泡沫灭火器
灭火时可能遭遇之特殊危害：无
特殊灭火程序：无
消防人员之特殊防护设备：无需

六、泄漏处理方法

个人应注意事项：穿带防护口罩，目镜，手套
环境注意事项：大幅升高水体COD值。
清理方法：深埋

七、安全处置与储存方法

处置：勿与易燃易爆品混放

储存：阴凉通风的地方

八、物理及化学性质

物质状态：固体	形状：不规则晶体
颜色：无色	气味：无
PH值：10%水溶液4-5	沸点/沸点范围： °C
分解温度：180 °C	闪火点： °F 580 °C 测试方法： 开杯 闭杯
自然温度：无	爆炸界限：无
蒸气压：无	蒸气密度：1.21
密度：1.76	溶解度：530 g/L (25 °C)

九、安定性及反应性

安定性：稳定

特殊状况下可能之危害反应：无

应避免之物质：易燃易爆品

危害分解物：无

十、毒性资料

急毒性：无

局部效应：灼伤

致敏感性：咳嗽

慢毒性或长期毒性：无

特殊效应：

十一、废弃处置方法

废弃处置方法：深埋

十二、运送资料

国际运送规定：按有害性化学品处置

国内运送规定：同上

特殊运送方法及注意事项：无

十三、其他资料

参考文献	中国国家环境保护法和美国化学文摘
制表单位	深圳鑫华昌表面处理技术有限公司
制表日期：	May-20

物质安全数据表 (MSDS)

1、物料及厂商资料

中文名称: HPb59-1、HPb59-3、C3601、C3602、C3604铜合金
用途: 用于水暖卫浴、玩具文具、电子电器、汽车配件、五金加工等工业领域
企业名称: 东莞市荣耀金属材料有限公司
地址: 东莞市寮步镇竹园村元英路原裕盛市场 B1栋 1号
邮编: 523000
电子地址邮编: 770182901@qq.com
传真号码: +86-0769-2198 7103
企业应急电话: +86-0769-2198 7103
技术说明书编码: 无
生效日期: 2022-08-16
国家应急电话: 112 119



2、成份/组成信息

混合物			
物料名称: HPb59-1、HPb59-3、C3601、C3602、C3604铜合金			
化学成份			
化学元素	名称	CAS No.	百分比 (wt%)
Cu	铜	7440-50-8	57-61
Fe	铁	7439-89-6	<0.5
Ni	镍	7440-02-0	<0.3
Sn	锡	7439-89-6/7440-31-5	<1.0
Pb	铅	7439-92-1	1.8-3.7
Cd	镉	7440-43-9	<0.01
Zn	锌	7440-66-6	余量



3、危害辨识资料

危害或危害信息：粉尘和烟雾有危害
对眼睛的影响：刺激性
对皮肤的影响：长期接触粉尘的工人常发生接触性皮炎
吸入的影响：引起呼吸道刺激症状，发生支气管炎或支气肺炎，甚至肺水肿
吞咽的影响：吞咽存在危害，恶心、呕吐、腹泻
慢性症状：长期吸入可引起肺部纤维组织增生

4、急救措施

皮肤接触：脱去污染的衣着，用肥皂水及清水彻底冲洗，就医
眼睛接触：立即翻开上下眼睑，用流动清水或生理盐水冲洗至少 15 分钟，就医
吸入、吞咽：迅速脱离现场至空气新鲜处，误服者立即漱口，饮牛奶或鸡蛋清就医

5、消防措施

危险特征：其粉体遇高温、明火能燃烧
有害燃烧产物：氧化铜
灭火方法及灭火剂：干粉、沙土
灭火注意事项：禁止用水

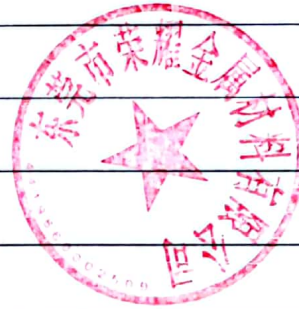

6、泄漏处理方法

应急处理：隔离泄漏污染区，周围设警示标志，切断火源。应急处理人员戴好防毒面具，穿一般消防防护服。
消除方法：避免扬尘，使用无火花工具收集于干燥净洁有盖的容器中，转移回收。当水体收到污染时，可采用加入纯碱中和，使铜以碱式碳酸铜形式沉淀而从水中转入污泥中，而污泥再做进一步的无害化处理。对于受铜污染的土壤，可采取排土、土层改良、深耕、施加石灰质矿物及磷酸钙等措施治理。

7、操作处理与储存



<p>操作注意事项: 制品边缘及断面容易割伤皮肤, 应小心处置 机械加工 (如切削及研磨等), 如产生粉尘应小心眼睛及皮肤接触, 需佩戴保护器具</p>
<p>储存注意事项: 储存于干燥通风良好室内场所或具有温湿度控制之空间; 严禁暴露于室外或温湿度高的密闭空间; 避免与酸、碱、盐类等化学物质一起储存。</p>

8、接触控制/个体防护

<p>暴露限制: Cu⇒ OSHA PEL: 1.0mg/m³</p>	<p>Pb⇒ OSHA PEL: 0.05mg/m³</p>
<p>Fe⇒ OSHA PEL: 1.0mg/m³</p>	<p>Sn⇒ OSHA PEL: 2.0mg/m³</p>
<p>Zn⇒ OSHA PEL: 10.0mg/m³</p>	
<p>工程控制: 安装排气装置, 在熔铸时应安装通风装置 (熔铸时由于金属挥发会产生粉尘)</p>	
<p>个人防护措施: 一般不需特殊防护, 但需防止烟尘危害</p>	

9、物理及化学性质

<p>外观与性状: 黄色金属</p>		
<p>气味: 无味</p>	<p>PH 值: N/A</p>	<p>密度: 约为 8.5g/cm³</p>
<p>蒸气压: N/A</p>	<p>蒸气密度: N/A</p>	<p>熔点: 约为 900℃</p>
<p>溶解性: 不溶于水, 溶于碱、盐酸、硫酸</p>		
<p>主要用途: 用于加工机械、电子零部件如螺钉螺母、阀件、五金零件等</p>		

10、稳定性及反应活性

<p>稳定性: 一边条件下相当稳定</p>	<p>禁配物: N/A</p>
<p>避免接触条件: 酸、碱、盐类禁止接触</p>	<p>聚合危害: N/A</p>
<p>分解产物: N/A</p>	

11、毒性资料

<p>急毒性: 属微毒类。污染来源为冶金、电镀、催化、仪表、合金和化工等的水和废渣</p>	
<p>亚急性和慢性毒性: 无相关资料</p>	
<p>刺激性: 无相关资料</p>	<p>致敏性: 粉尘接触皮肤少数人过敏</p>
<p>致突变性: 无相关资料</p>	<p>致畸性: 无相关资料</p>
<p>致癌性: 无相关资料</p>	<p>其它: 无相关资料</p>

12、生态学资料

生态毒性：无相关资料	生物降解性：无相关资料
非生物降解性：无相关资料	生物富集或生物积累性：无相关资料
其它有害作用：利用含铜废水灌溉农田或施用含铜污泥，铜可积累在土壤中。随水进入到土壤中的铜可被土壤吸持。土壤中的腐殖酸、富里酸含有羧基、酚基、羰基等含氧基团，能与铜形成螯合物而固定铜	

13、废弃处置

废弃物性质：工业固体废物
废弃处置方法：回收再利用
废弃注意事项：与其他废弃物分开放置，便于在利用

14、运输信息

危险货物编号：非危险货物	UN 编号：N/A
包装标识：N/A	包装类别：N/A
包装方法：散装或包装箱	
运输注意事项：防止货物跌落、重压、渗水	

15、法规信息

无相关法规

16、其他信息

参考文献：GB16483《化学品安全技术说明书编写规定》



物质安全技术说明书(MSDS)

1. 产品及企业标识

- 产品名：聚四氟乙烯棒
- 产品英文名：PTFE
- 生产企业名称：维业新材料科技（嘉兴）有限公司
- 地址：浙江省平湖市独山港振业路 333 号 3 号楼
- 邮编：314100
- 生效日期：2023 年 1 月 3 日

2. 成分/组成信息

主要成份	含量%	CAS 编号
聚四氟乙烯（PTFE）	100	9002-84-0

3. 危险性概述

- 危害性类别：不在《常用危险化学品的分类及标志》（GB 13690-92）中
- 侵害途径：吸入，眼睛接触，皮肤接触。
- 健康危害：正常处理时不会产生危害。当加工时，材料在超过分解温度时可能产生有毒气体。吸入，灰尘会引起呼吸道刺激。暴露在 PTFE 分解产物中，可能导致聚合体烟雾发烧症状。有流感症状（高烧、冷颤、肌肉痛）；眼睛接触，灰尘会导致机械性刺激；皮肤接触，灰尘会导致机械性刺激；

4. 急救措施

- 皮肤接触：无需就医。
- 眼睛接触：用大量水冲洗，不要揉搓眼睛，如症状持续，需立刻就医。
- 吸入：移到新鲜空气中，保持呼吸通畅，如症状持续，需立刻就医。
- 食入：无需就医。

5. 消防措施

- 有害燃烧产物：一氧化碳，二氧化碳，氟化氢。

- 灭火方法及灭火剂：使用水雾，泡沫，干粉和 CO₂。
- 灭火注意事项：消防员应携带自给式空气呼吸器 (SCBA) 和全身防护服。

6. 泄露应急处理

- 隔离泄露污染区,限制出入。
- 个人防护措施,如有毒气体产生,穿戴合适的个人防护用品。不要吸入粉尘。清除火源。防止接触皮肤和眼睛;环境预防措施,防止进入下水道,地表水或者土壤;清除方法,清扫或者铲入合适的容器,等待废弃处理。防止产生气载灰尘。

7. 操作处置与储存

- 操作注意事项: 密闭操作,提供良好的自然通风条件。
操作人员必须经过专门培训,严格遵守操作流程。建议操作人员佩戴自吸过滤式防尘口罩。
远离火种,热源,工作场所严禁吸烟。
使用防爆型的通风系统和设备。避免产生粉尘。避免与氧化剂接触。
搬运时要轻装轻卸,防止包装及容器损坏。
配备相应品种和数量的消防器材及泄露应急处理设备。倒空的容器可能残留有害物。
- 储存注意事项: 储存于阴凉,通风的库房。
远离火种,热源。应与氧化剂分开存放,切忌混储。
配备相应品种和数量的消防器材。
储区应备有合适的材料收容泄露物。

8. 接触控制/个体防护

- 中国MAC (mg/m³):未制定标准
- 眼睛防护: 必要时,佩戴化学安全防护眼镜。
- 其他: 如有潜在暴露的地方,提供安全淋浴或者洗眼器。当材料被加工或者产生过多粉尘,不要抽烟或者保留烟雾物质在生产区域。吃饭或者抽烟前彻底清洗手。

9. 物理、化学、机械与电力特性

- 外观形态: 通常为固态白色,半透明体,有板、棒、管、膜及异性部件等形态。
- 熔点: 327 °C

- 标准相对密度：2.1~2.3g/cm³
- 吸水率：≤0.00
- 拉伸强度：15-30 Mpa
- 断裂伸长率：200-350 %
- 介电常数：2.5-10Kv/mm

10. 稳定性和反应活性

- 禁配物：强氧化剂

11. 毒理学资料

- 无资料提供

12. 生态学资料

- 无资料提供

13. 废弃处置

- 废弃处理方法：请回收废料。在允许接受化学品废物设备中进行处理。如燃烧处理有可能产生氟化氢。

14. 运输信息

- 运输注意事项：起运时包装要完整，装载应稳妥。运输过程中要确保容器不泄露，不倒塌，不坠落，不损坏。严禁与氧化剂等混装混运。运输途中应防暴晒，雨淋，防高温。

15. 法规信息

- 国内化学品安全法规：《危险化学品安全管理条例》（2002年3月15日国务院发布），针对危险化学品的安全生产、使用、储存、运输、装卸等方面均作出了相应规定。
- 国际法规：欧盟指示 2002/95/EC (RoHS) 符合

16. 其他信息

- 参考文献： 无资料
- 提示：本表所含的信息来源于我们认为准确的数据，但是未提供有关数据准确性或相关使用结果的明确或暗示性的保证。
- 嘉善伟业四氟制品厂对于由本材料导致购买方，用户或第三方所发生的人生伤害或财产损失不承担任何责任。相关材料使用的风险则由购买方或用户承担。