



中国认可
国际互认
检测
TESTING
CNAS L0446



Page 1 of 45

Test Report

Verified code: 811926

Report No.: E202204024904-1

Customer: Chengdu Vantron Technology Co., Ltd.

Address: No.5 GaoPeng Road, Hi-Tech Zone, Chengdu, SiChuan, P.R. China 610045

Sample Name: Wireless Module

Sample Model: VT-ANT-257

Receive Sample Date: Apr.02,2022

Test Date: Apr.02,2022 ~ Apr.02,2022

Reference Document: CFR 47, FCC Part 15 Subpart C
RADIO FREQUENCY DEVICES: Subpart C—Intentional Radiators

Test Result: Pass

Prepared by: *Wen Wen*

Reviewed by: *Wu Haoting*

Approved by: *Xiao Liang*

GUANGZHOU GRG METROLOGY & TEST CO., LTD

Issued Date: 2022-04-02

GUANGZHOU GRG METROLOGY & TEST CO., LTD.

Address: No.163, Pingyun Road, West of Huangpu Avenue, Guangzhou, Guangdong, China
Tel: (+86) 400-602-0999 FAX: (+86) 020-38698685 Web: <http://www.grgtest.com>



Statement

1. The report is invalid without "special seal for inspection and testing"; some copies are invalid; The report is invalid if it is altered or missing; The report is invalid without the signature of the person who prepared, reviewed and approved it.
2. The sample information is provided by the client and responsible for its authenticity; The content of the report is only valid for the samples sent this time.
3. When there are reports in both Chinese and English, the Chinese version will prevail when the language problems are inconsistent.
4. If there is any objection concerning the report, please inform us within 15 days from the date of receiving the report.
5. Without the agreement of the laboratory, the client is not authorized to use the test results for unapproved propaganda.

----- The following blanks -----

TABLE OF CONTENTS

1.	TEST RESULT SUMMARY	5
2.	GENERAL DESCRIPTION OF DUT	6
2.1	APPLICANT	6
2.2	MANUFACTURER	6
2.3	FACTORY	6
2.4	BASIC DESCRIPTION OF EQUIPMENT UNDER TEST	6
2.5	TEST OPERATION MODE	7
2.6	FREQUENCY BAND AND THE TEST FREQUENCY	7
3.	LABORATORY AND ACCREDITATIONS	8
3.1	LABORATORY	8
3.2	ACCREDITATIONS	8
3.3	MEASUREMENT UNCERTAINTY	8
4.	EQUIPMENT AND TOOLS USED DURING TEST	9
4.1	LIST OF USED TEST EQUIPMENT AT GRGT	9
4.2	LOCAL SUPPORTIVE	10
4.3	CONFIGURATION OF SYSTEM UNDER TEST	10
4.4	TEST SOFTWARE	10
5.	RADIATED SPURIOUS EMISSIONS	11
5.1	LIMITS	11
5.2	TEST PROCEDURES	12
5.3	TEST SETUP	16
5.4	TEST RESULT	18
6.	RESTRICTED BANDS	35
6.1	LIMITS	35
6.2	TEST PROCEDURES	36
6.3	TEST SETUP	36
6.4	TEST RESULT	37
7.	20DB BANDWIDTH	41
7.1	LIMITS	41
7.2	TEST PROCEDURES	41
7.3	TEST SETUP	41
7.4	TEST RESULTS	41
8.	APPENDIX A. PHOTOGRAPH OF THE TEST CONNECTION DIAGRAM	44
9.	APPENDIX B. PHOTOGRAPH OF THE EUT	45

REPORT ISSUED HISTORY

Report Version	Report No.	Description	Compile Date
1.0	E202204024904-1	Original Issue	2022/04/02

----- The following blanks -----

1. TEST RESULT SUMMARY

CFR 47, FCC Part 15 Subpart C ANSI C63.10:2013		
Standard	Test Item	Result
§15.249(a), §15.249(c)	Spurious Emissions	Pass
§15.215(c)	20dB bandwidth	Pass
§15.249(d)	Restricted bands	Pass
§15.203	Antenna Requirement	Pass

Note : The antenna type is an integrated antenna, which meets the requirements according to 15.203.

----- The following blanks -----

2. GENERAL DESCRIPTION OF DUT

2.1 APPLICANT

Name: Chengdu Vantron Technology Co., Ltd.
Address: No.5 GaoPeng Road, Hi-Tech Zone, Chengdu, SiChuan, P.R. China 610045

2.2 MANUFACTURER

Name: Chengdu Vantron Technology Co., Ltd.
Address: No.5 GaoPeng Road, Hi-Tech Zone, Chengdu, SiChuan, P.R. China 610045

2.3 FACTORY

Name: Chengdu Vantron Technology Co., Ltd.
Address: No.5 GaoPeng Road, Hi-Tech Zone, Chengdu, SiChuan, P.R. China 610045

2.4 BASIC DESCRIPTION OF EQUIPMENT UNDER TEST

Equipment: Wireless Module
Model No.: VT-ANT-257
Adding Model: /
Trade Name: Vantron
FCC ID: 2AAGE-257
Power Supply: DC 3V
Frequency Range: 2450MHz~2457MHz
Transmit Power: Peak: 95.52dBuV/m (Max.)
Average: 66.65dBuV/m (Max.)
Type of Modulation: GFSK
Antenna Specification: PCB antenna with 0.8dBi gain (Max.)
Temperature Range: -40 °C ~ +85 °C
Hardware Version: V1.1
Software Version: V1.1
Sample No: E202204024904-0001, E202204024904-0002
Note: /

2.5 TEST OPERATION MODE

Mode No.	Description of the modes
1	Continuously Transmitting

2.6 FREQUENCY BAND AND THE TEST FREQUENCY

Channel	Frequency (MHz)
50	2450
51	2451
52	2452
53	2453
54	2454
55	2455
56	2456
57	2457

Note: 50* & 57* is the test channel.

----- The following blanks -----

3. LABORATORY AND ACCREDITATIONS

3.1 LABORATORY

The tests & measurements refer to this report were performed by Shenzhen EMC Laboratory of Guangzhou GRG Metrology & Test Co., Ltd.

Add.: No.1301 Guanguang Road Xinlan Community, Guanlan Street, Longhua District Shenzhen, 518110, People's Republic of China.
P.C.: 518000
Tel : 0755-61180008
Fax: 0755-61180008

3.2 ACCREDITATIONS

Our laboratories are accredited and approved by the following approval agencies according to ISO/IEC 17025.

USA A2LA (Certificate#:2861.01)

China CNAS (L0446)

The measuring facility of laboratories has been authorized or registered by the following approval agencies.

Canada ISED (Company Number: 24897, CAB identifier:CN0069)

USA FCC (Registration Number: 759402, Designation Number:CN1198)

Copies of granted accreditation certificates are available for downloading from our web site, <http://www.grgtest.com>

3.3 MEASUREMENT UNCERTAINTY

Where relevant, the following measurement uncertainty levels have been estimated for tests performed on the EUT as specified in CISPR 16-4-2:

Measurement		Frequency	Uncertainty
Radiated Emission	Horizontal	9kHz~30MHz	4.46dB
		30MHz~1000MHz	4.30dB
		1GHz~18GHz	5.60dB
		18GHz~26.5GHz	3.65dB
	Vertical	9kHz~30MHz	4.46dB
		30MHz~1000MHz	4.30dB
		1GHz~18GHz	5.60dB
		18GHz~26.5GHz	3.65dB

Measurement	Uncertainty
Occupied channel bandwidth	0.4 dB

This uncertainty represents an expanded uncertainty factor of k=2.

4. EQUIPMENT AND TOOLS USED DURING TEST

4.1 LIST OF USED TEST EQUIPMENT AT GRGT

Name of Equipment	Manufacturer	Model	Serial Number	Calibration Due
Radiated Spurious Emission & Restricted bands of operation				
TEST RECEIVER	R&S	ESU26	EMC26-G260	2022-08-20
Spectrum Analyzer	Keysight	N9020B	MY5712019	2022-08-08
Loop Antenna	TESEQ	HLA6121	52599	2022-04-21
Bi-log Antenna	TESEQ	CBL6143A	32399	2022-11-25
Horn Antenna	Schwarzbeck	BBHA 9120D (1201)	02143	2022-10-22
Horn Antenna	Schwarzbeck	BBHA 9170	BBHA 9170-497	2022-10-16
Amplifier	Tonscend	TAP9E6343	AP20E806065	2022-06-03
Amplifier	Tonscend	TAP01018048	AP20E8060075	2022-05-09
Amplifier	Tonscend	TAP184050	AP20E806071	2022-05-17
Test S/W	Tonscend	JS32-RE/2.5.2.4		
20 dB Bandwidth				
Spectrum Analyzer	Keysight	N9020B	MY5712019	2022-08-08

Note: The used test instrument calibration interval time is one year.

----- The following blanks -----

4.2 LOCAL SUPPORTIVE

Name of Equipment	Manufacturer	Model	Serial Number	Note	
Notebook	LENOVO	TianYi 310-14ISK	MP18DLC6	/	
Adapter (Notebook)	LENOVO	ADLX65NCC3A	N/A	/	
Tablet	Hydrow	CVC15101	V15101214700006	/	
Cable					
No.	Name of Equipment	Manufacturer	Model	Serial Number	Note
1	USB cable	/	/	/	Unshielded, 1.00m
2	DC cable	/	/	/	Shielded, 1.80m

4.3 CONFIGURATION OF SYSTEM UNDER TEST

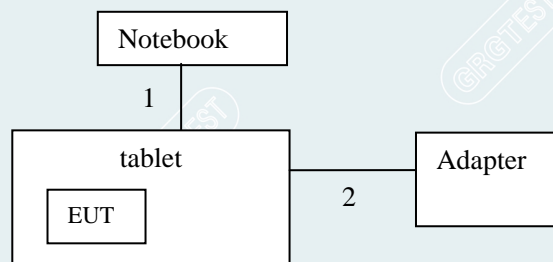

4.4 TEST SOFTWARE

Software version	Test level
Adb tool	Default

5. RADIATED SPURIOUS EMISSIONS

5.1 LIMITS

The field strength of fundamental and harmonic emissions, measured at 3 m, shall not exceed 50 mV/m and 0.5 mV/m respectively.

Fundamental Frequency	Field Strength of Fundamental Field Strength (mV/m)	Field Strength of Harmonics (μ V/m)
902-928 MHz	50	500
2400 - 2483.5 MHz	50	500
5725 - 5875 MHz	50	500

Except where otherwise indicated in the applicable FCC, radiated emissions shall comply with the field strength limits shown in table 5 and table 6. Additionally, the level of any transmitter unwanted emission shall not exceed the level of the transmitter's fundamental emission.

Table 5

Frequency (MHz)	Magnetic field strength (H Field) (μ A/m)	Measurement Distance (m)
0.009-0.490	$6.37/F$ (F in kHz)	300
0.490-1.705	$63.7/F$ (F in kHz)	30
1.705-30.0	0.08	30

Table 6

Frequency (MHz)	Field Strength (μ V/m)	Measurement Distance (m)
30-88	100*	3
88-216	150*	3
216-960	200*	3
Above 960	500	3

Restricted band

MHz	MHz	MHz	GHz
0.090 - 0.110	16.42 - 16.423	1435 - 1626.5	4.5 – 5.15
¹ 0.495 - 0.505	16.69475 - 16.69525	1645.5 - 1646.5	5.35 – 5.46
2.1735 - 2.1905	16.80425 - 16.80475	1660 - 1710	7.25 -7.75
4.125 - 4.128	25.5 - 25.67	1718.8 - 1722.2	8.025 -8.5
4.17725 - 4.17775	37.5 - 38.25	2200 - 2300	9.0 - 9.2
4.20725 - 4.20775	73 - 74.6	2310 - 2390	9.3 - 9.5
6.215 - 6.218	74.8 - 75.2	2483.5 - 2500	10.6 - 12.7
6.26775 - 6.26825	108 – 121.94	2690 - 2900	13.25 - 13.4
6.31175 - 6.31225	123 – 138	3260 - 3267	14.47 - 14.5
8.291 - 8.294	149.9 - 150.05	3332 - 3339	15.35 - 16.2
8.362 - 8.366	156.52475 - 156.52525	3345.8 - 3358	17.7 - 21.4
8.37625 - 8.38675	156.7 - 156.9	3600 - 4400	22.01 - 23.12
8.41425 - 8.41475	162.0125 - 167.17		23.6 - 24.0
12.29 - 12.293	167.72 - 173.2		31.2 - 31.8
12.51975 - 12.52025	240 - 285		36.43 - 36.5
12.57675 - 12.57725	322 - 335.4		Above 38.6
13.36 - 13.41	399.9 – 410		
	608 – 614		
	960 - 1240		
	1300 - 1427		

5.2 TEST PROCEDURES

1) Sequence of testing 9 kHz to 30 MHz

Setup:

- The equipment was set up to simulate a typical usage like described in the user manual or described by manufacturer.
- If the EUT is a tabletop system, a rotatable table with 0.8 m height is used.
- If the EUT is a floor standing device, it is placed on the ground.
- Auxiliary equipment and cables are placed on the table and operate in fixed-frequency mode for continuous transmission.
- The DC power port of the EUT (if any) is connected to the supplied PCB board so that it can work properly.
- The measurement distance is 3 meter.
- The EUT was set into operation.

Pre measurement:

- The turntable rotates continuously from 0 to 360 °.
- The antenna height is 1 meter.
- At each turntable position the analyzer sweeps with peak detection to find the maximum of all emissions

Final measurement:

- Identified emissions during the pre measurement the software maximizes by rotating the turntable position (0° to 360°) and by rotating the elevation axes (0° to 360°).
- The final measurement will be done in the position (turntable and elevation) causing the highest emissions with QPK detector.
- The final levels, frequency, measuring time, bandwidth, turntable position, correction factor, margin to the limit and limit will be recorded. Also a plot with the graph of the pre measurement and the limit will be stored.

2) Sequence of testing 30 MHz to 1 GHz**Setup:**

- The equipment was set up to simulate a typical usage like described in the user manual or described by manufacturer.
- If the EUT is a tabletop system, a table with 0.8 m height is used, which is placed on the ground plane.
- If the EUT is a floor standing device, it is placed on the ground plane with insulation between both.
- Auxiliary equipment and cables are placed on the table and operate in fixed-frequency mode for continuous transmission.
- The DC power port of the EUT (if any) is connected to the supplied PCB board so that it can work properly.
- The measurement distance is 3 meter.
- The EUT was set into operation.

Pre measurement:

- The turntable rotates continuously from 0 to 360° .
- The antenna is polarized vertical and horizontal.
- The antenna height changes from 1 to 4 meter.
- At each turntable position, antenna polarization and height the analyzer sweeps three times in peak to find the maximum of all emissions.

Final measurement:

- The final measurement will be performed with minimum the six highest peaks.
- According to the maximum antenna and turntable positions of premeasurement the software maximize the peaks by changing turntable position (0 to 360°) and antenna movement between 1 and 4 meter.
- The final measurement will be done with QP detector with an EMI receiver.
- The final levels, frequency, measuring time, bandwidth, antenna height, antenna polarization, turntable angle, correction factor, margin to the limit and limit will be recorded. Also a plot with the graph of the premeasurement with marked maximum final measurements and the limit will be stored.

3) Sequence of testing 1 GHz to 18 GHz**Setup:**

- The equipment was set up to simulate a typical usage like described in the user manual or described by manufacturer.

- If the EUT is a tabletop system, a rotatable table with 1.5 m height is used.
- If the EUT is a floor standing device, it is placed on the ground plane with insulation between both.
- Auxiliary equipment and cables are placed on the table and operate in fixed-frequency mode for continuous transmission.
- The DC power port of the EUT (if any) is connected to the supplied PCB board so that it can work properly.
- The measurement distance is 3 meter.
- The EUT was set into operation.

Pre measurement:

- The turntable rotates continuously from 0 to 360 °.
- The antenna is polarized vertical and horizontal.
- The antenna height scan range is 1 meter to 4 meter.
- At each turntable position and antenna polarization the analyzer sweeps with peak detection to find the maximum of all emissions.

Final measurement:

- The final measurement will be performed with minimum the six highest peaks.
- According to the maximum antenna and turntable positions of premeasurement the software maximize the peaks by changing turntable position (0 to 360 °) and antenna movement between 1 and 4 meter. This procedure is repeated for both antenna polarizations.
- The final measurement will be done in the position (turntable, EUT-table and antenna polarization) causing the highest emissions with Peak and Average detector.
- The final levels, frequency, measuring time, bandwidth, turntable position, EUT-table position, antenna polarization, correction factor, margin to the limit and limit will be recorded. Also a plot with the graph of the pre measurement with marked maximum final measurements and the limit will be stored.

4) Sequence of testing above 18 GHz**Setup:**

- The equipment was set up to simulate a typical usage like described in the user manual or described by manufacturer.
- If the EUT is a tabletop system, a rotatable table with 1.5 m height is used.
- If the EUT is a floor standing device, it is placed on the ground plane with insulation between both.
- Auxiliary equipment and cables are placed on the table and operate in fixed-frequency mode for continuous transmission.
- The DC power port of the EUT (if any) is connected to the supplied PCB board so that it can work properly.
- The measurement distance is 1 meter.
- The EUT was set into operation.

Pre measurement:

- The antenna is moved spherical over the EUT in different polarisations of the antenna.

Final measurement:

- The final measurement will be performed at the position and antenna orientation for all detected emissions that were found during the Scan the test chart with Peak and Average detector.
- The final levels, frequency, measuring time, bandwidth, correction factor, margin to the limit and limit will be recorded. Also a plot with the graph of the Scan the test chart and the limit will be stored.

NOTE:

- (a).The frequency from 9kHz to 150kHz, Set RBW=300Hz(for Peak&AVG), RBW=300Hz(for Peak&AVG).
the frequency from 150kHz to 30MHz, Set RBW=9kHz, RBW=9kHz, (for QP Detector).
- (b).The frequency from 30MHz to 1GHz, Set RBW=120kHz, RBW=300kHz, (for QP Detector).
- (c).The frequency above 1GHz, for Peak detector: Set RBW=1MHz, RBW=3MHz.
- (d).The frequency above 1GHz, for Avg detector: Set RBW=1MHz, if the EUT is configured to transmit with duty cycle $\geq 98\%$, set $VBW \leq RBW/100$ (i.e.,10kHz) but not less than 10Hz. if the EUT duty cycle is $< 98\%$, set $VBW \geq 1/T$, Where T is defined in section 5.4.

----- The following blanks -----

5.3 TEST SETUP

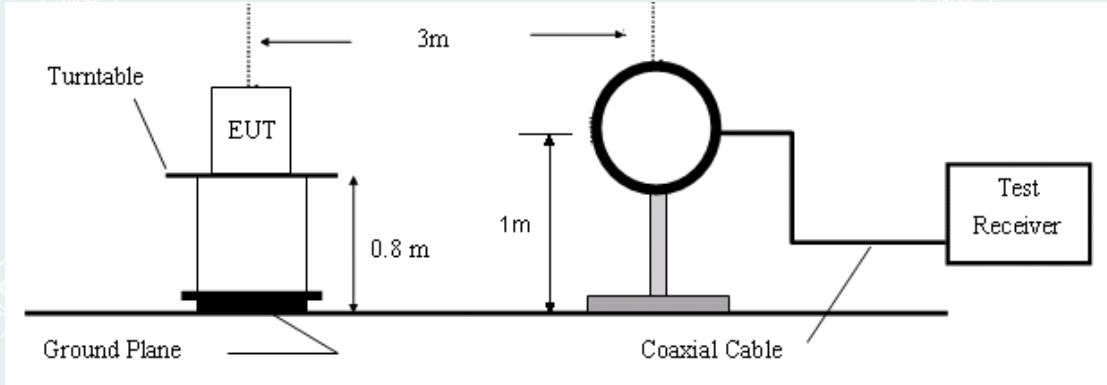

Figure 1. 9kHz to 30MHz radiated emissions test configuration

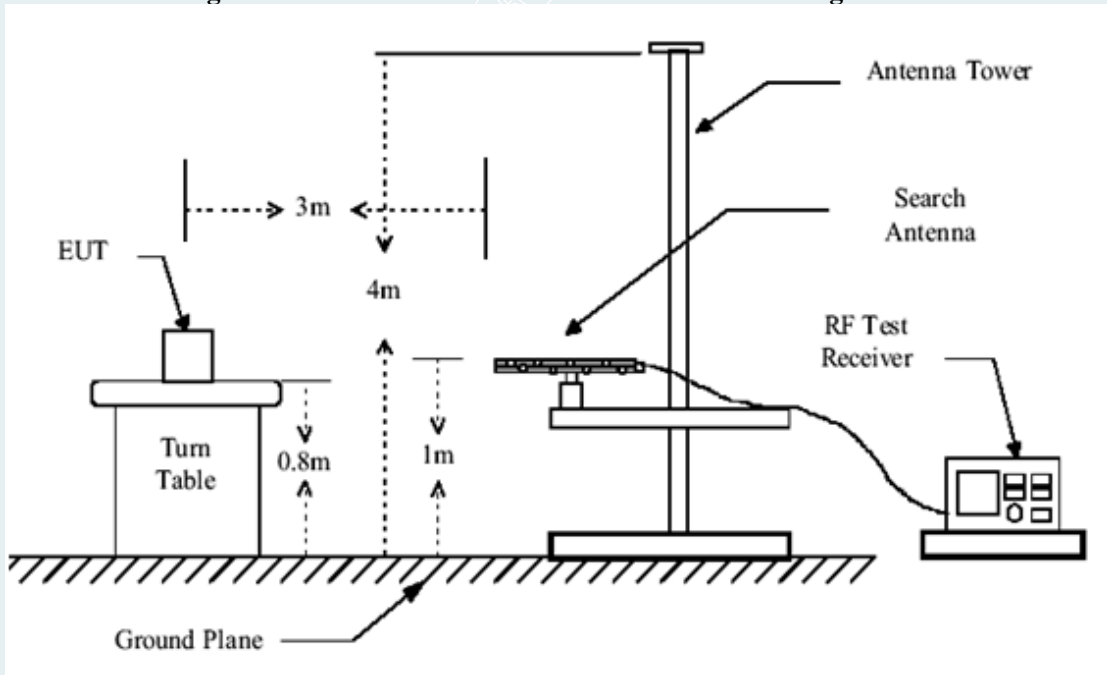

Figure 2. 30MHz to 1GHz radiated emissions test configuration

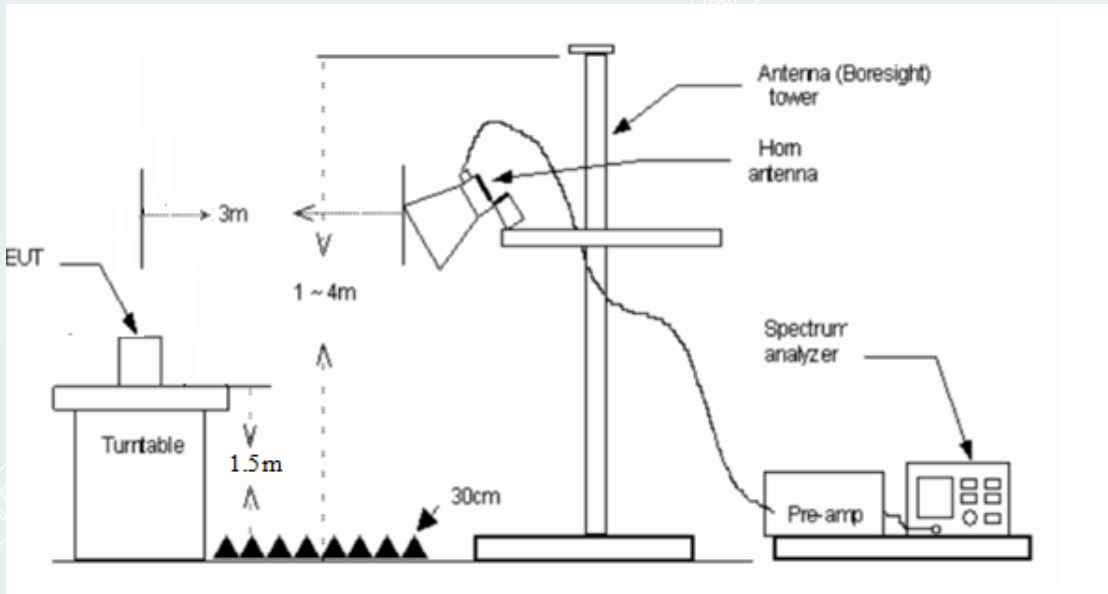

Figure 3. 1GHz-18GHz radiated emissions test configuration

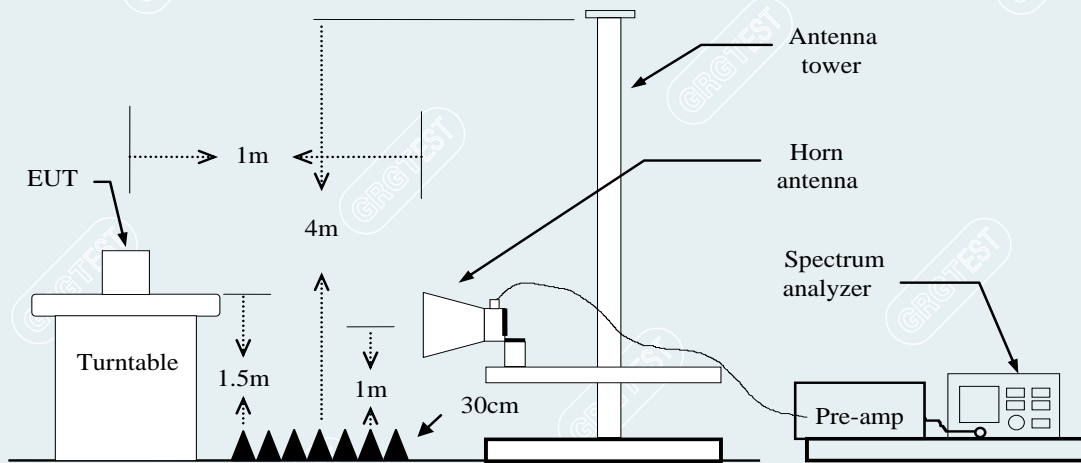
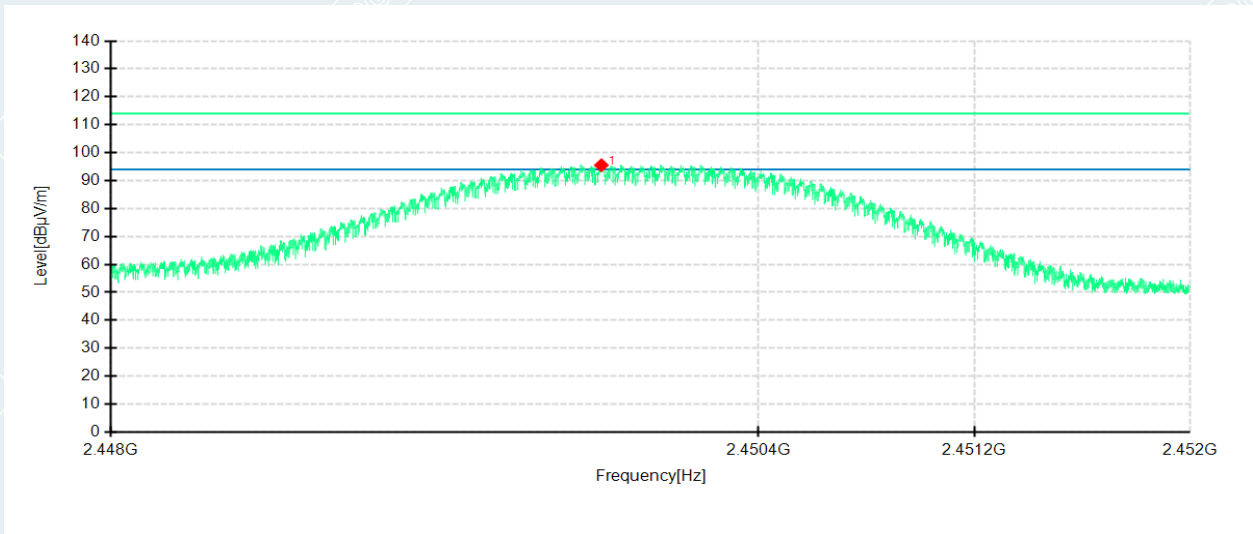

Figure 4. 18GHz-26.5GHz radiated emissions test configuration

The field strength of fundamental

EUT Name	Wireless Module	Model	VT-ANT-257
Environmental Conditions	25°C/60%RH	Test Mode	Mode 1
Power supply	DC 3V	Tested By	Lu Qiang
Test Date	2022-04-02	Sample No.	E202204024904-0001
Frequency	2450 MHz	/	/



PEAK

Freq. [MHz]	Reading [dBµV/m]	Level [dBµV/m]	Factor [dB]	Limit [dBµV/m]	Margin [dB]	Height [cm]	Angle [°]	Polarity	Remark
2449.8172	91.85	95.52	3.67	114.00	18.48	100	252	Horizontal	Peak

AVG

Freq. [MHz]	Level [dBµV/m]	Limit [dBµV/m]	Margin [dB]	Remark
2449.8172	66.65	94.00	27.35	AV

Note 1: AVG Level value=Peak Level value + Duty Cycle Factor

Note 2: Duty Cycle Factor= (20*Log(Duty Cycle))= 20*Log(0.036) =-28.87

Note 3: AVG Level value=95.52(dBµV/m) - 28.87(dB) = 66.65(dBµV/m).

----- The following blanks -----

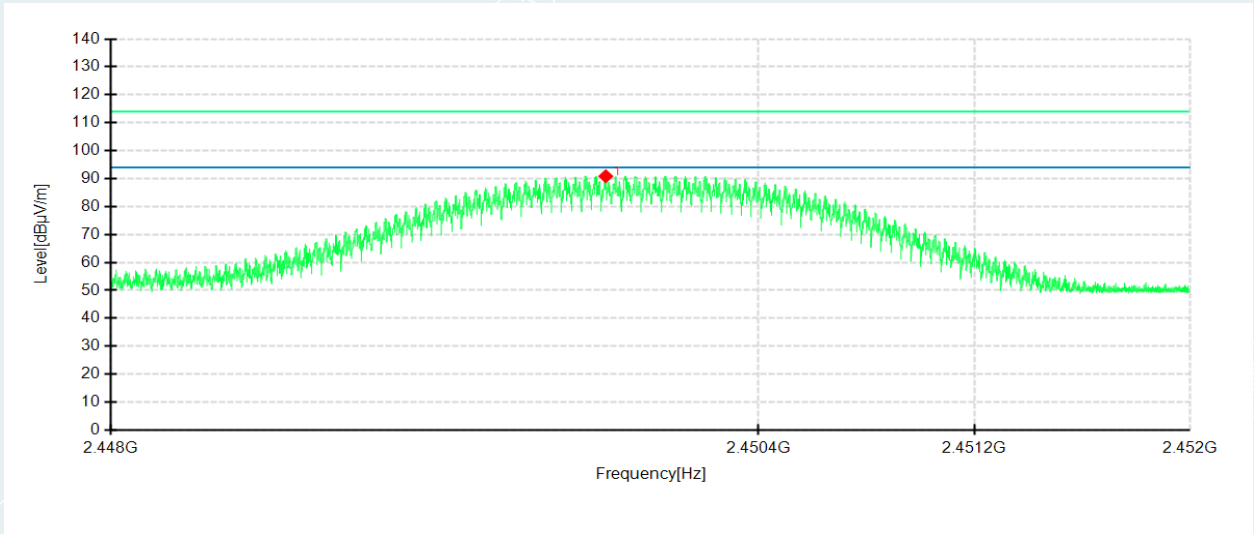

PEAK

Freq. [MHz]	Reading [dBµV/m]	Level [dBµV/m]	Factor [dB]	Limit [dBµV/m]	Margin [dB]	Height [cm]	Angle [°]	Polarity	Remark
2449.8336	87.28	90.85	3.57	114.00	23.15	200	264	Vertical	Peak

AVG

Freq. [MHz]	Level [dBµV/m]	Limit [dBµV/m]	Margin [dB]	Remark
2449.8336	61.98	94.00	32.02	AV

Note 1: AVG Level value=Peak Level value + Duty Cycle Factor

Note 2: Duty Cycle Factor= (20*Log(Duty Cycle))= 20*Log(0.036) =-28.87

Note 3: AVG Level value=90.85(dBµV/m) -28.87(dB) = 61.98(dBµV/m).

----- The following blanks -----

EUT Name	Wireless Module	Model	VT-ANT-257
Environmental Conditions	25°C/60%RH	Test Mode	Mode 1
Power supply	DC 3V	Tested By	Lu Qiang
Test Date	2022-04-02	Sample No.	E202204024904-0001
Frequency	2457 MHz	/	/

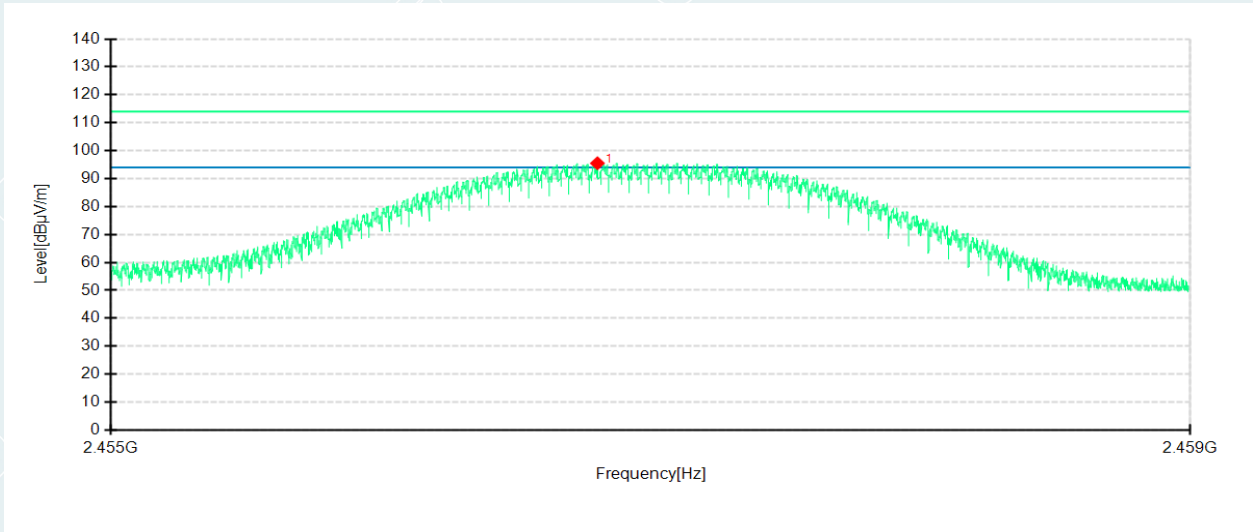

PEAK

Freq. [MHz]	Reading [dBµV/m]	Level [dBµV/m]	Factor [dB]	Limit [dBµV/m]	Margin [dB]	Height [cm]	Angle [°]	Polarity	Remark
2456.8024	91.69	95.49	3.80	114.00	18.51	100	252	Horizontal	Peak

AVG

Freq. [MHz]	Level [dBµV/m]	Limit [dBµV/m]	Margin [dB]	Remark
2456.8024	66.62	94.00	27.38	AV

Note 1: AVG Level value=Peak Level value + Duty Cycle Factor

Note 2: Duty Cycle Factor= (20*Log(Duty Cycle))= 20*Log(0.036) =-28.87

Note 3: AVG Level value=95.49(dBµV/m) -28.87(dB) = 66.62(dBµV/m).

----- The following blanks -----

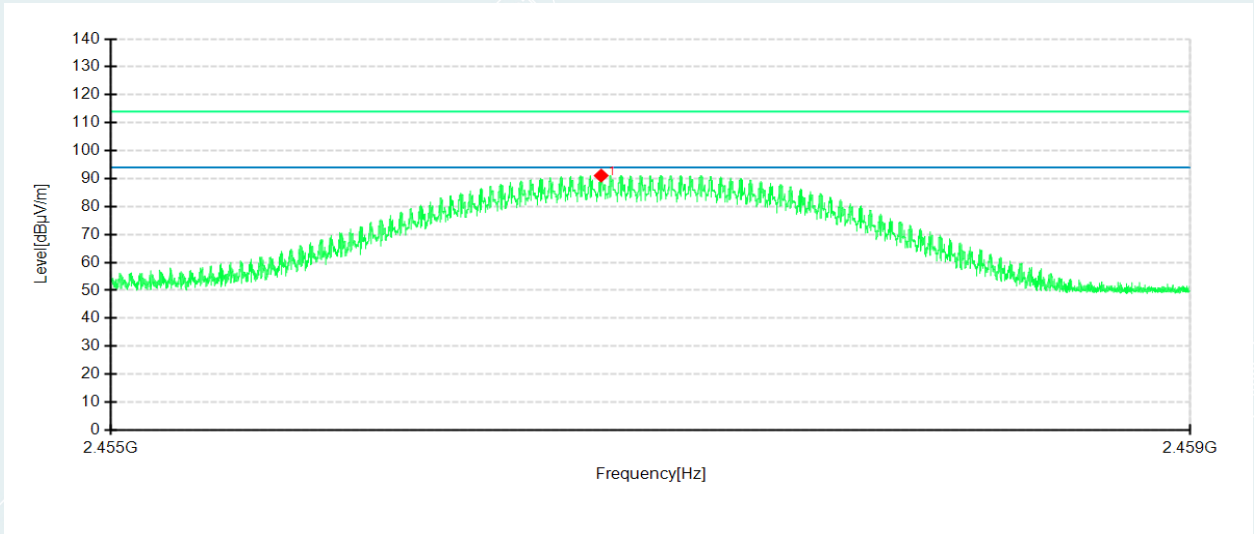

PEAK

Freq. [MHz]	Reading [dBµV/m]	Level [dBµV/m]	Factor [dB]	Limit [dBµV/m]	Margin [dB]	Height [cm]	Angle [°]	Polarity	Remark
2456.8164	87.49	91.08	3.59	114.00	22.92	200	265	Vertical	Peak

AVG

Freq. [MHz]	Level [dBµV/m]	Limit [dBµV/m]	Margin [dB]	Remark
2456.8164	62.21	94.00	31.79	AV

Note 1: AVG Level value=Peak Level value + Duty Cycle Factor

Note 2: Duty Cycle Factor= (20*Log(Duty Cycle))= 20*Log(0.036) =-28.87

Note 3: AVG Level value=91.08 (dBµV/m) -28.87(dB) = 62.21 (dBµV/m).

----- The following blanks -----

Radiated Spurious Emission

Test Frequency 30MHz – 1GHz

EUT Name	Wireless Module	Model	VT-ANT-257
Environmental Conditions	24.1°C/51%RH	Test Mode	Mode 1
Power supply	DC 3V	Tested By	Tang Shenghui
Test Date	2022-04-02	Sample No.	E202204024904-0001
Frequency	2450 MHz	Polarity:	Horizontal

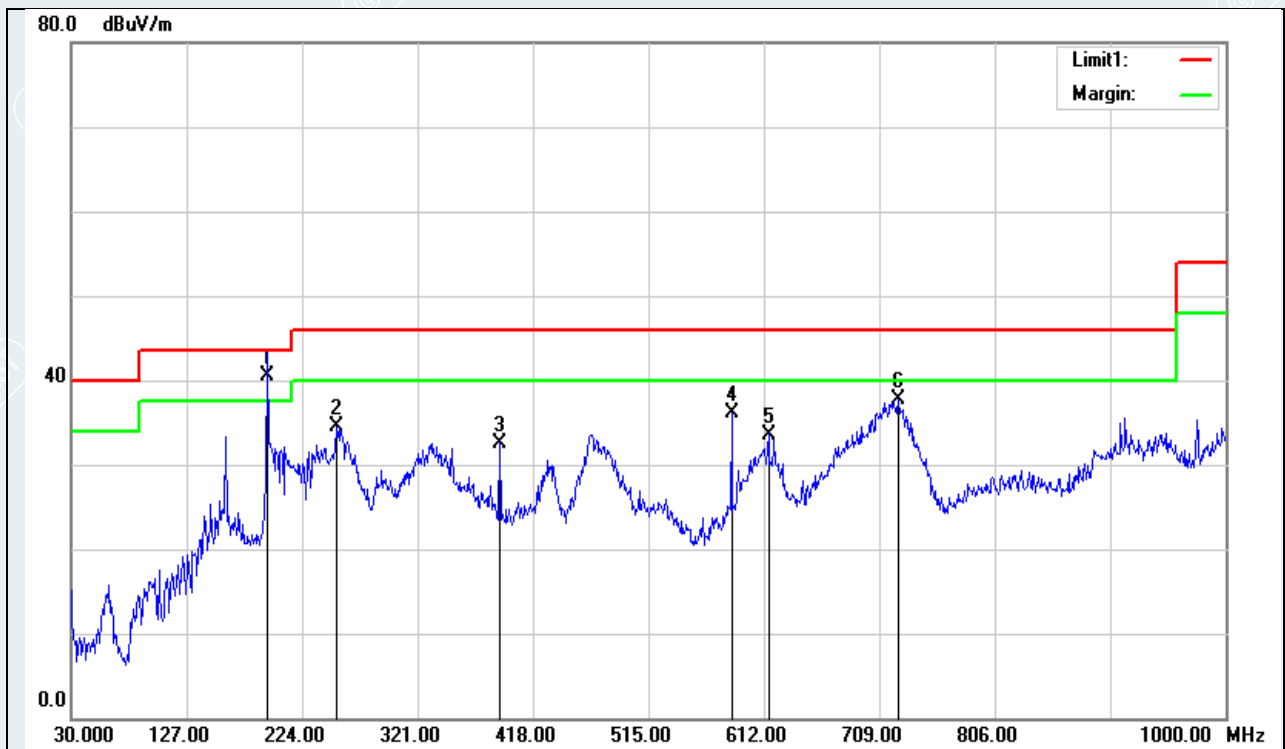

No.	Frequency (MHz)	Reading (dBuV)	Correct Factor(dB/m)	Result (dBuV/m)	Limit (dBuV/m)	Margin (dB)	Height (cm)	Degree (deg)	Remark
1*	194.9000	67.93	-27.33	40.60	43.50	-2.90	137	360	QP
2	253.1000	59.84	-25.25	34.59	46.00	-11.41	100	177	QP
3	389.8700	53.47	-20.87	32.60	46.00	-13.40	178	360	QP
4	584.8400	51.60	-15.52	36.08	46.00	-9.92	199	44	QP
5	615.8800	48.40	-14.80	33.60	46.00	-12.40	100	222	QP
6	724.5200	50.47	-12.80	37.67	46.00	-8.33	100	3	QP

EUT Name	Wireless Module	Model	VT-ANT-257
Environmental Conditions	24.1°C/51%RH	Test Mode	Mode 1
Power supply	DC 3V	Tested By	Tang Shenghui
Test Date	2022-04-02	Sample No.	E202204024904-0001
Frequency	2450 MHz	Polarity:	Vertical

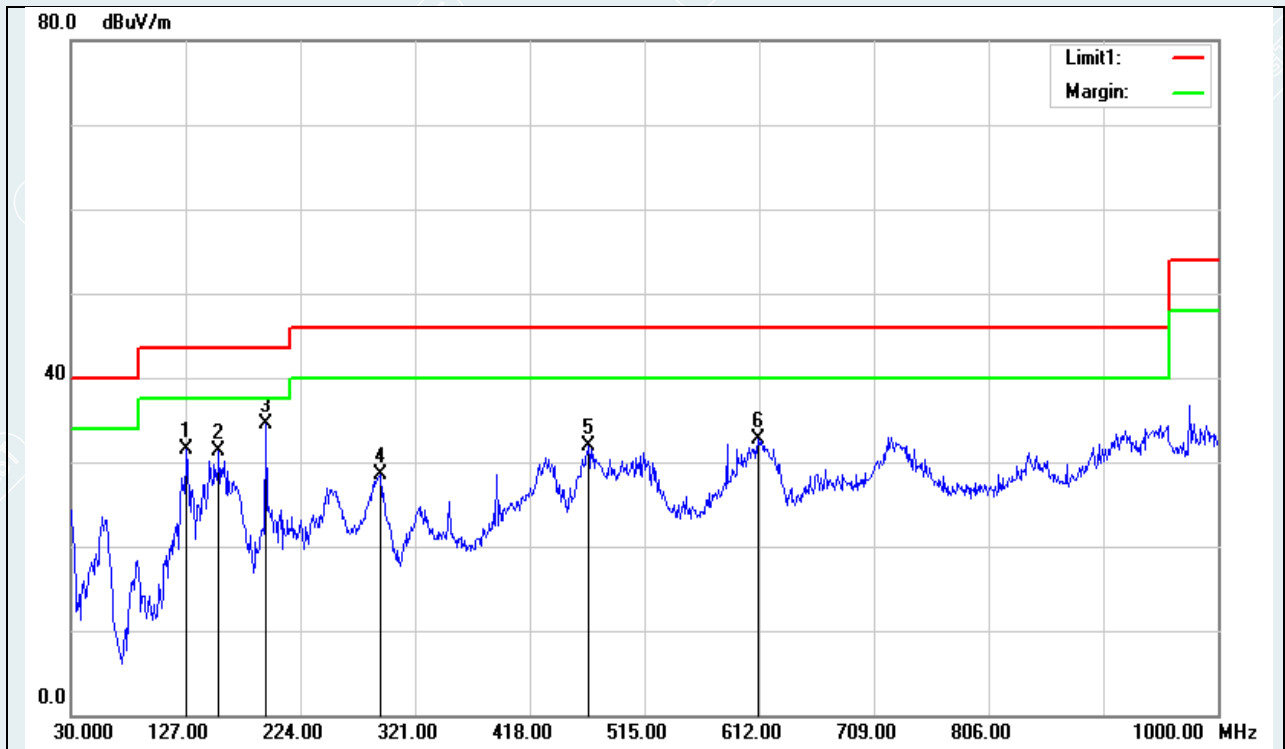

No.	Frequency (MHz)	Reading (dBuV)	Correct Factor(dB/m)	Result (dBuV/m)	Limit (dBuV/m)	Margin (dB)	Height (cm)	Degree (deg)	Remark
1	127.9700	57.82	-26.36	31.46	43.50	-12.04	100	225	QP
2	155.1300	56.24	-24.90	31.34	43.50	-12.16	100	258	QP
3*	194.9000	61.78	-27.33	34.45	43.50	-9.05	100	26	QP
4	291.9000	52.32	-23.86	28.46	46.00	-17.54	199	0	QP
5	467.4700	50.39	-18.46	31.93	46.00	-14.07	100	184	QP
6	611.0300	47.63	-14.88	32.75	46.00	-13.25	100	303	QP

EUT Name	Wireless Module	Model	VT-ANT-257
Environmental Conditions	24.1°C/51%RH	Test Mode	Mode 1
Power supply	DC 3V	Tested By	Tang Shenghui
Test Date	2022-04-02	Sample No.	E202204024904-0001
Frequency	2457 MHz	Polarity:	Horizontal

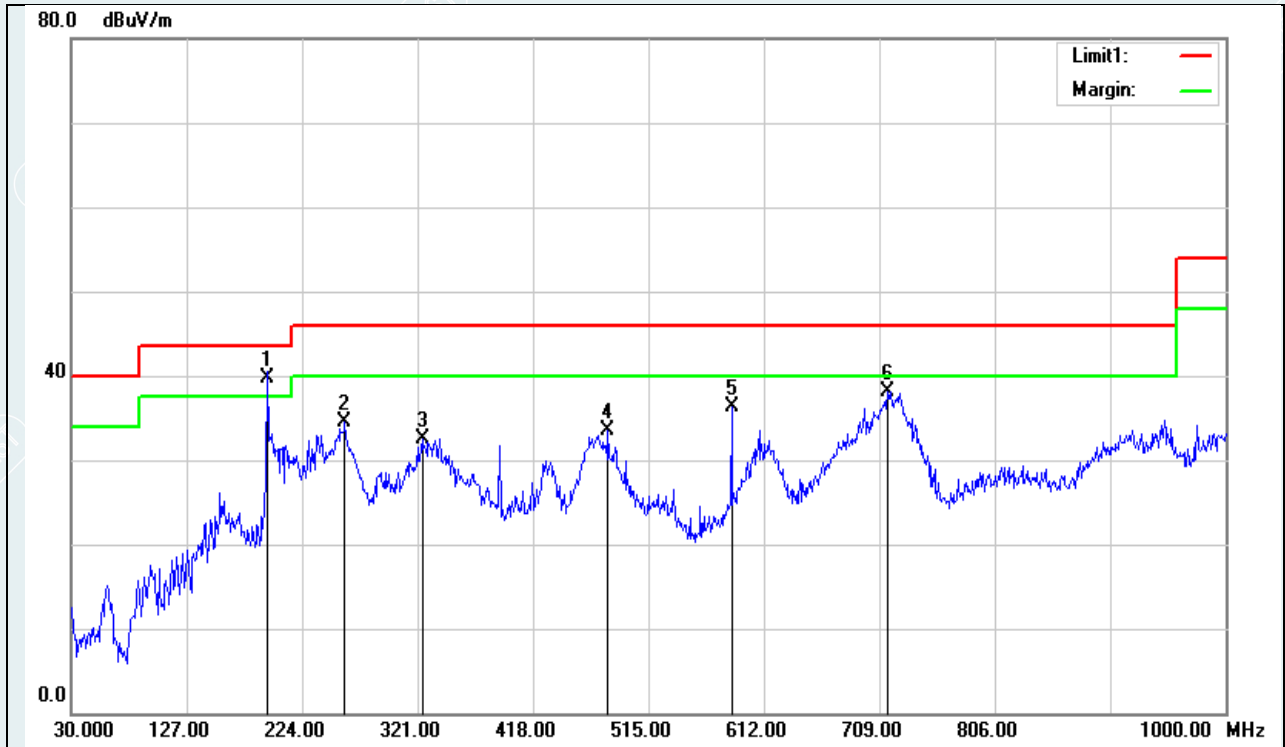

No.	Frequency (MHz)	Reading (dBuV)	Correct Factor(dB/m)	Result (dBuV/m)	Limit (dBuV/m)	Margin (dB)	Height (cm)	Degree (deg)	Remark
1*	194.9000	67.13	-27.33	39.80	43.50	-3.70	201	0	QP
2	259.8900	59.45	-25.00	34.45	46.00	-11.55	100	179	QP
3	324.8800	55.48	-22.95	32.53	46.00	-13.47	100	191	QP
4	481.0500	51.82	-18.22	33.60	46.00	-12.40	145	360	QP
5	584.8400	51.83	-15.52	36.31	46.00	-9.69	200	51	QP
6	715.7900	51.06	-12.99	38.07	46.00	-7.93	100	27	QP

EUT Name	Wireless Module	Model	VT-ANT-257
Environmental Conditions	24.1°C/51%RH	Test Mode	Mode 1
Power supply	DC 3V	Tested By	Tang Shenghui
Test Date	2022-04-02	Sample No.	E202204024904-0001
Frequency	2457 MHz	Polarity:	Vertical

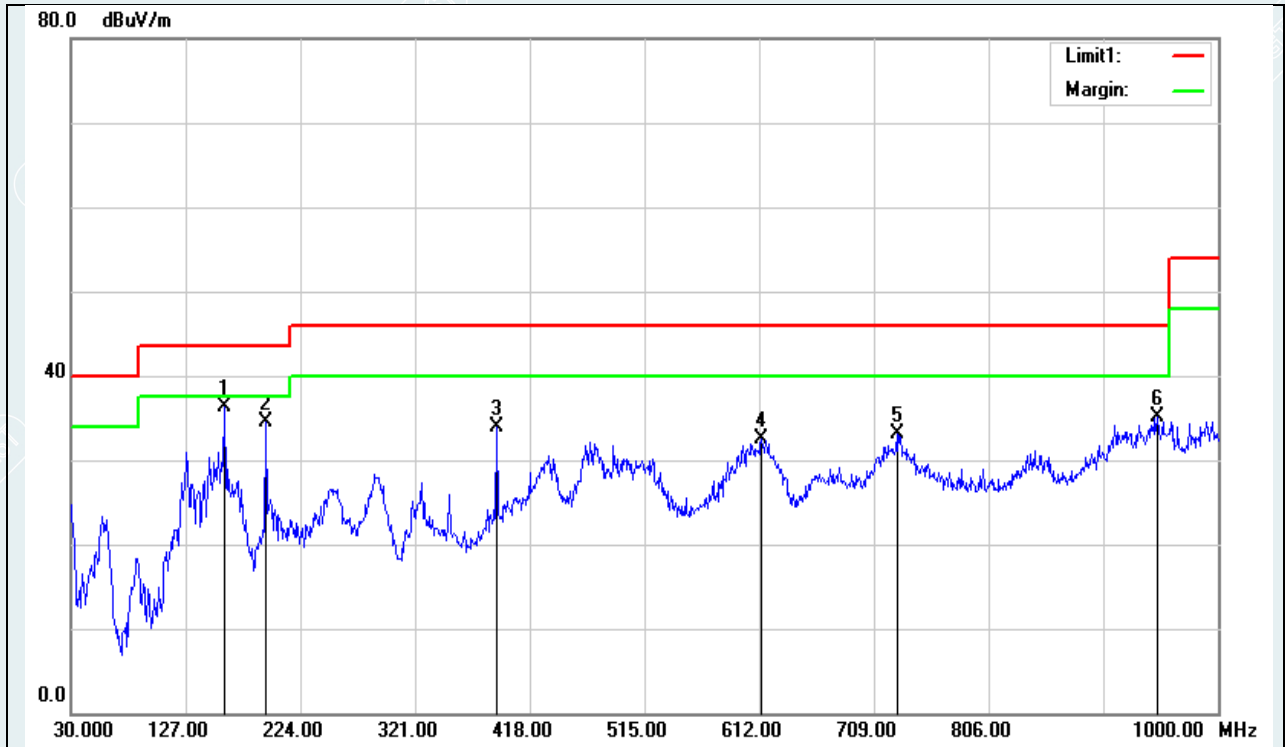

No.	Frequency (MHz)	Reading (dBuV)	Correct Factor(dB/m)	Result (dBuV/m)	Limit (dBuV/m)	Margin (dB)	Height (cm)	Degree (deg)	Remark
1*	159.9800	61.37	-24.99	36.38	43.50	-7.12	199	324	QP
2	194.9000	61.86	-27.33	34.53	43.50	-8.97	100	27	QP
3	389.8700	54.78	-20.87	33.91	46.00	-12.09	100	154	QP
4	613.9400	47.29	-14.83	32.46	46.00	-13.54	199	307	QP
5	728.4000	45.74	-12.72	33.02	46.00	-12.98	129	0	QP
6	948.5900	44.57	-9.42	35.15	46.00	-10.85	100	358	QP

Remark:

1. No emission found between lowest internal used/generated frequency to 30MHz.
2. Radiated emissions measured in frequency range from 30MHz to 1GHz were made with an instrument using Quasi-peak detector mode.
3. The IF bandwidth of Receiver between 30MHz to 1GHz was 120kHz.
4. After the X/Y/Z axis test, it is found that the X axis result is the worst, so only the X axis test results were recorded in the report.

Above 1 GHz (1-18G)

EUT Name	Wireless Module	Model	VT-ANT-257
Environmental Conditions	25°C/60%RH	Test Mode	Mode 1
Power supply	DC 3V	Tested By	Lu Qiang
Test Date	2022-04-02	Sample No.	E202204024904-0001
Frequency	2450 MHz	/	/

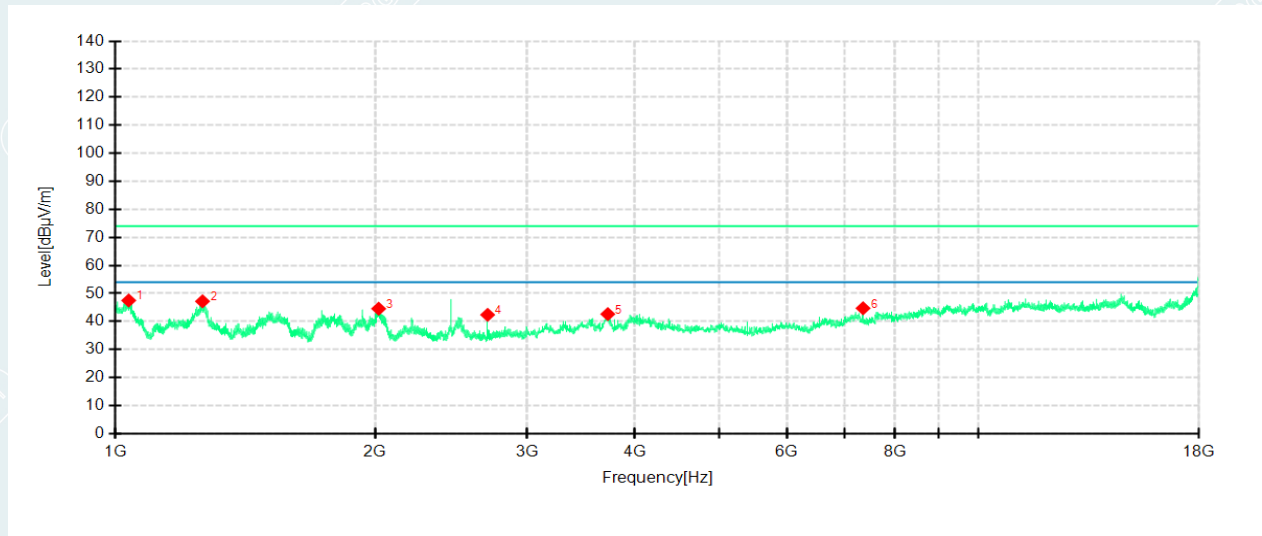

Suspected Data List									
NO.	Freq. [MHz]	Reading [dBµV/m]	Level [dBµV/m]	Factor [dB]	Limit [dBµV/m]	Margin [dB]	Height [cm]	Angle [°]	Polarity
1	1036.5046	72.02	47.50	-24.52	74.00	26.50	100	51	Horizontal
2	1262.0328	69.23	47.19	-22.04	74.00	26.81	100	80	Horizontal
3	2018.8774	65.53	44.56	-20.97	74.00	29.44	100	230	Horizontal
4	2699.9625	61.58	42.37	-19.21	74.00	31.63	100	209	Horizontal
5	3720.0900	58.39	42.63	-15.76	74.00	31.37	100	349	Horizontal
6	7348.6686	49.87	44.72	-5.15	74.00	29.28	100	334	Horizontal

EUT Name	Wireless Module	Model	VT-ANT-257
Environmental Conditions	25°C/60%RH	Test Mode	Mode 1
Power supply	DC 3V	Tested By	Lu Qiang
Test Date	2022-04-02	Sample No.	E202204024904-0001
Frequency	2450 MHz	/	/

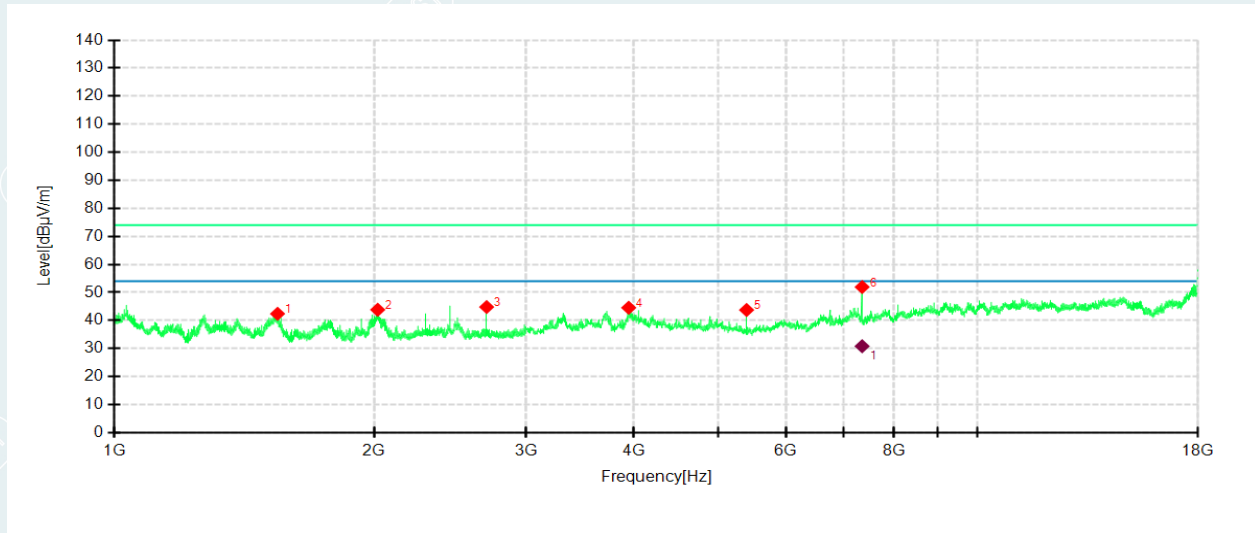

Suspected Data List

NO.	Freq. [MHz]	Reading [dBμV/m]	Level [dBμV/m]	Factor [dB]	Limit [dBμV/m]	Margin [dB]	Height [cm]	Angle [°]	Polarity
1	1545.8182	65.92	42.39	-23.53	74.00	31.61	200	270	Vertical
2	2018.8774	63.95	43.83	-20.12	74.00	30.17	200	230	Vertical
3	2699.9625	62.92	44.81	-18.11	74.00	29.19	100	302	Vertical
4	3943.2429	60.33	44.54	-15.79	74.00	29.46	100	142	Vertical
5	5400.3000	54.39	43.73	-10.66	74.00	30.27	100	214	Vertical
6	7350.5438	57.48	51.93	-5.55	74.00	22.07	100	148	Vertical

AV Final Data List

NO.	Freq. [MHz]	Factor [dB]	AV Reading [dBμV/m]	AV Value [dBμV/m]	AV Limit [dBμV/m]	AV Margin [dB]	Height [cm]	Angle [°]	Polarity
1	7349.2942	-5.55	36.37	30.82	54.00	23.18	100	53.7	Vertical

EUT Name	Wireless Module	Model	VT-ANT-257
Environmental Conditions	25°C/60%RH	Test Mode	Mode 1
Power supply	DC 3V	Tested By	Lu Qiang
Test Date	2022-04-02	Sample No.	E202204024904-0001
Frequency	2457 MHz	/	/

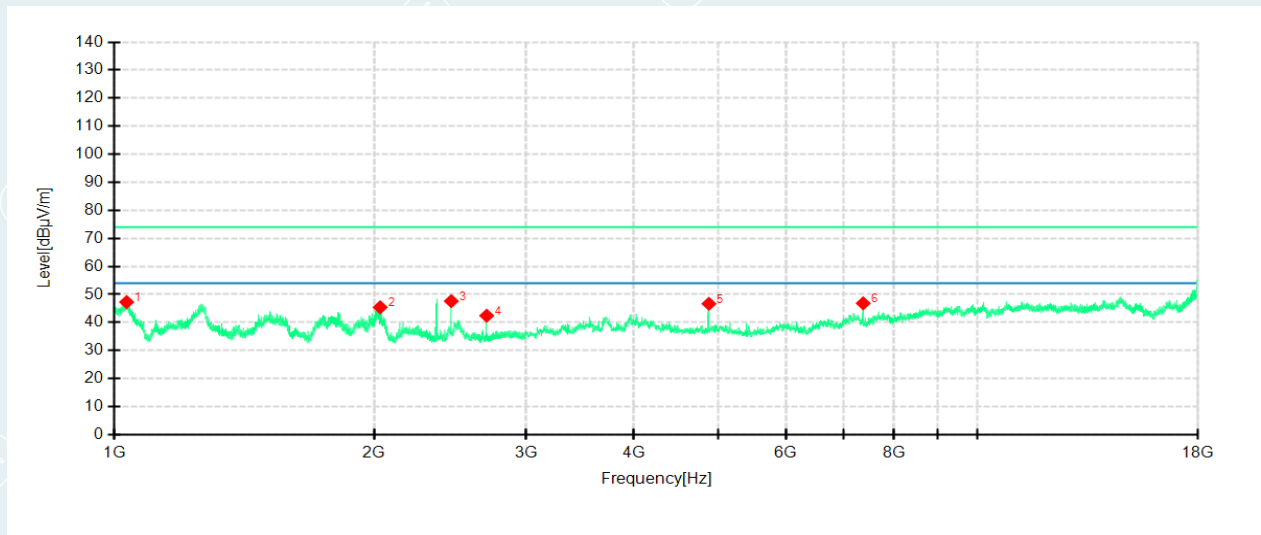

Suspected Data List									
NO.	Freq. [MHz]	Reading [dBµV/m]	Level [dBµV/m]	Factor [dB]	Limit [dBµV/m]	Margin [dB]	Height [cm]	Angle [°]	Polarity
1	1033.5042	71.77	47.30	-24.47	74.00	26.70	100	65	Horizontal
2	2032.3790	66.40	45.43	-20.97	74.00	28.57	100	228	Horizontal
3	2456.9321	63.30	47.61	-15.69	74.00	26.39	200	265	Horizontal
4	2700.2125	61.63	42.43	-19.20	74.00	31.57	100	209	Horizontal
5	4884.6106	58.72	46.67	-12.05	74.00	27.33	200	135	Horizontal
6	7371.1714	52.28	46.84	-5.44	74.00	27.16	200	245	Horizontal

EUT Name	Wireless Module	Model	VT-ANT-257
Environmental Conditions	25°C/60%RH	Test Mode	Mode 1
Power supply	DC 3V	Tested By	Lu Qiang
Test Date	2022-04-02	Sample No.	E202204024904-0001
Frequency	2457 MHz	/	/

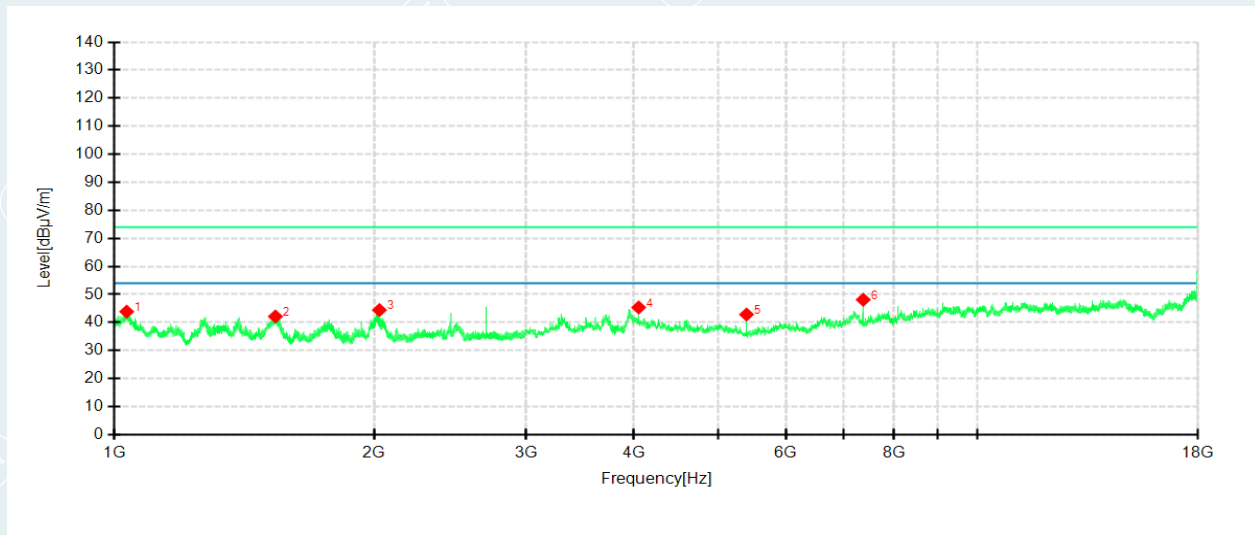

Suspected Data List									
NO.	Freq. [MHz]	Reading [dBμV/m]	Level [dBμV/m]	Factor [dB]	Limit [dBμV/m]	Margin [dB]	Height [cm]	Angle [°]	Polarity
1	1033.7542	67.62	43.88	-23.74	74.00	30.12	100	93	Vertical
2	1536.8171	65.62	42.14	-23.48	74.00	31.86	200	270	Vertical
3	2028.3785	64.46	44.42	-20.04	74.00	29.58	200	230	Vertical
4	4050.1313	59.93	45.37	-14.56	74.00	28.63	100	80	Vertical
5	5400.3000	53.51	42.85	-10.66	74.00	31.15	100	184	Vertical
6	7371.1714	54.00	48.12	-5.88	74.00	25.88	200	101	Vertical

Note:

1. Radiated emissions measured in frequency range from 1GHz – 18GHz were made with an instrument using Peak/AV detector mode.
2. According to C63.10, if the peak (or quasi-peak) measured value complies with the average limit, it's unnecessary to perform an average measurement.
3. The IF bandwidth of Receiver between above was 1MHz.
4. After the X/Y/Z axis test, it is found that the X axis result is the worst, so only the X axis test results were recorded in the report.

18-26.5GHz:

EUT Name	Wireless Module	Model	VT-ANT-257
Environmental Conditions	25°C/60%RH	Test Mode	Mode 1
Power supply	DC 3V	Tested By	Lu Qiang
Test Date	2022-04-02	Sample No.	E202204024904-0001
Frequency	2450 MHz	/	/

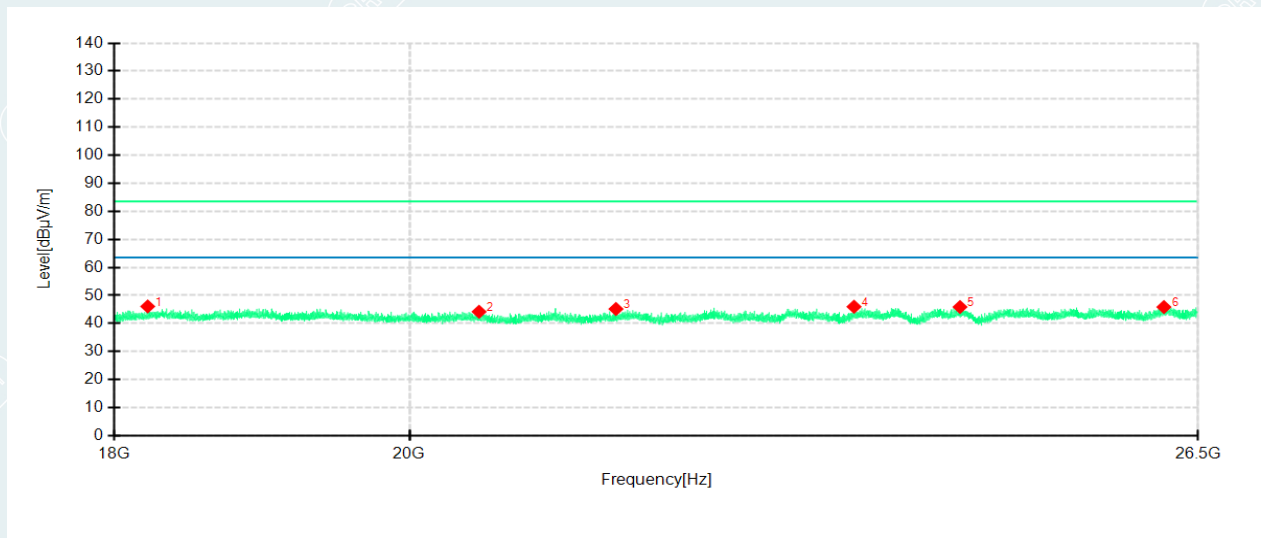

Suspected Data List									
NO.	Freq. [MHz]	Reading [dBµV/m]	Level [dBµV/m]	Factor [dB]	Limit [dBµV/m]	Margin [dB]	Height [cm]	Angle [°]	Polarity
1	18216.3250	57.67	46.08	-11.59	83.54	37.46	150	125	Horizontal
2	20503.2500	54.68	44.19	-10.49	83.54	39.35	150	180	Horizontal
3	21529.6250	55.15	45.17	-9.98	83.54	38.37	150	158	Horizontal
4	23438.7250	54.71	45.97	-8.74	83.54	37.57	150	243	Horizontal
5	24342.7000	54.05	45.88	-8.17	83.54	37.66	150	95	Horizontal
6	26179.9750	53.83	45.86	-7.97	83.54	37.68	150	147	Horizontal

EUT Name	Wireless Module	Model	VT-ANT-257
Environmental Conditions	25°C/60%RH	Test Mode	Mode 1
Power supply	DC 3V	Tested By	Lu Qiang
Test Date	2022-04-02	Sample No.	E202204024904-0001
Frequency	2450 MHz	/	/

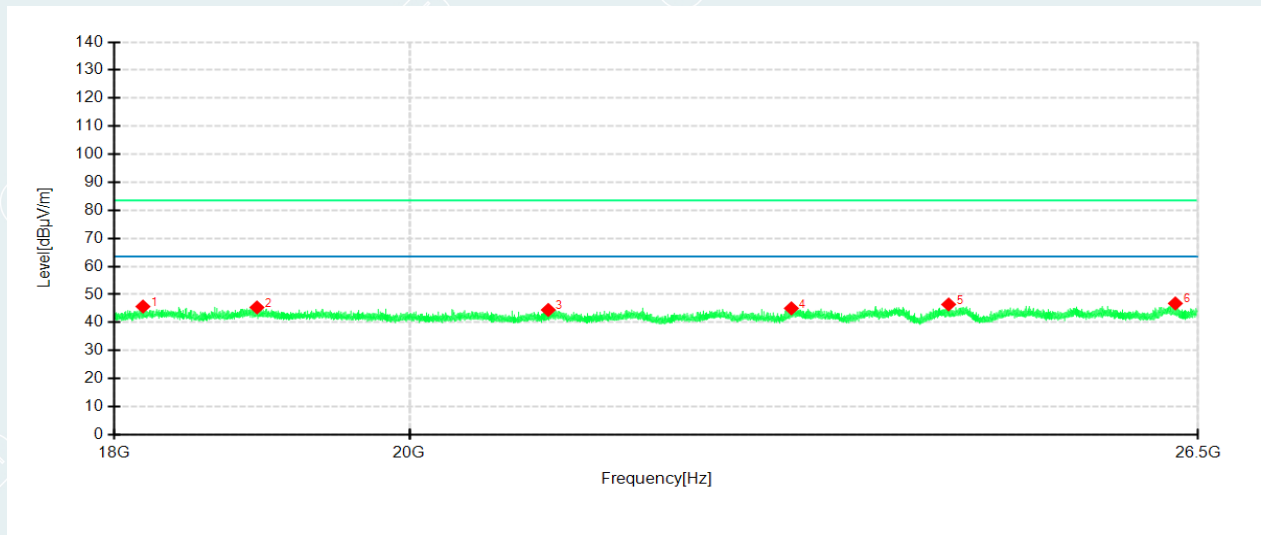

Suspected Data List									
NO.	Freq. [MHz]	Reading [dBµV/m]	Level [dBµV/m]	Factor [dB]	Limit [dBµV/m]	Margin [dB]	Height [cm]	Angle [°]	Polarity
1	18185.3000	57.28	45.68	-11.60	83.54	37.86	150	51	Vertical
2	18940.5250	56.53	45.38	-11.15	83.54	38.16	150	254	Vertical
3	21015.8000	54.78	44.48	-10.30	83.54	39.06	150	359	Vertical
4	22920.6500	54.02	45.03	-8.99	83.54	38.51	150	359	Vertical
5	24243.6750	54.64	46.44	-8.20	83.54	37.10	150	318	Vertical
6	26287.0750	54.52	46.80	-7.72	83.54	36.74	150	350	Vertical

EUT Name	Wireless Module	Model	VT-ANT-257
Environmental Conditions	25°C/60%RH	Test Mode	Mode 1
Power supply	DC 3V	Tested By	Lu Qiang
Test Date	2022-04-02	Sample No.	E202204024904-0001
Frequency	2457 MHz	/	/

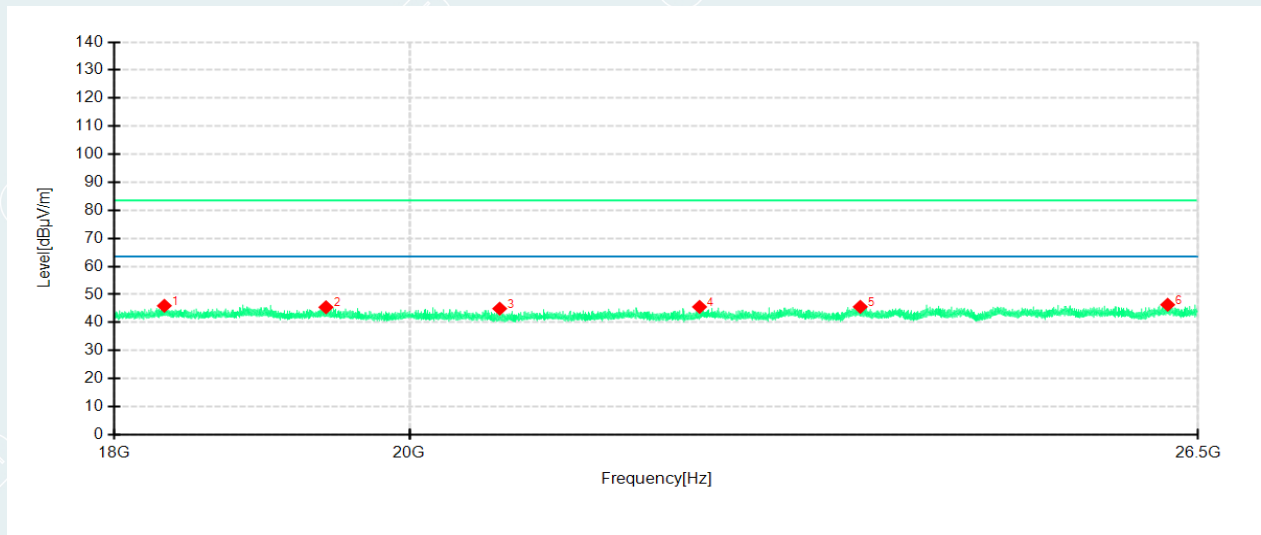

Suspected Data List									
NO.	Freq. [MHz]	Reading [dBµV/m]	Level [dBµV/m]	Factor [dB]	Limit [dBµV/m]	Margin [dB]	Height [cm]	Angle [°]	Polarity
1	18324.7000	57.51	45.96	-11.55	83.54	37.58	150	318	Horizontal
2	19413.1250	56.40	45.43	-10.97	83.54	38.11	150	211	Horizontal
3	20654.5500	55.33	44.93	-10.40	83.54	38.61	150	169	Horizontal
4	22181.5750	55.30	45.55	-9.75	83.54	37.99	150	9	Horizontal
5	23491.0000	54.30	45.58	-8.72	83.54	37.96	150	95	Horizontal
6	26215.2500	54.21	46.32	-7.89	83.54	37.22	150	190	Horizontal

EUT Name	Wireless Module	Model	VT-ANT-257
Environmental Conditions	25°C/60%RH	Test Mode	Mode 1
Power supply	DC 3V	Tested By	Lu Qiang
Test Date	2022-04-02	Sample No.	E202204024904-0001
Frequency	2457 MHz	/	/

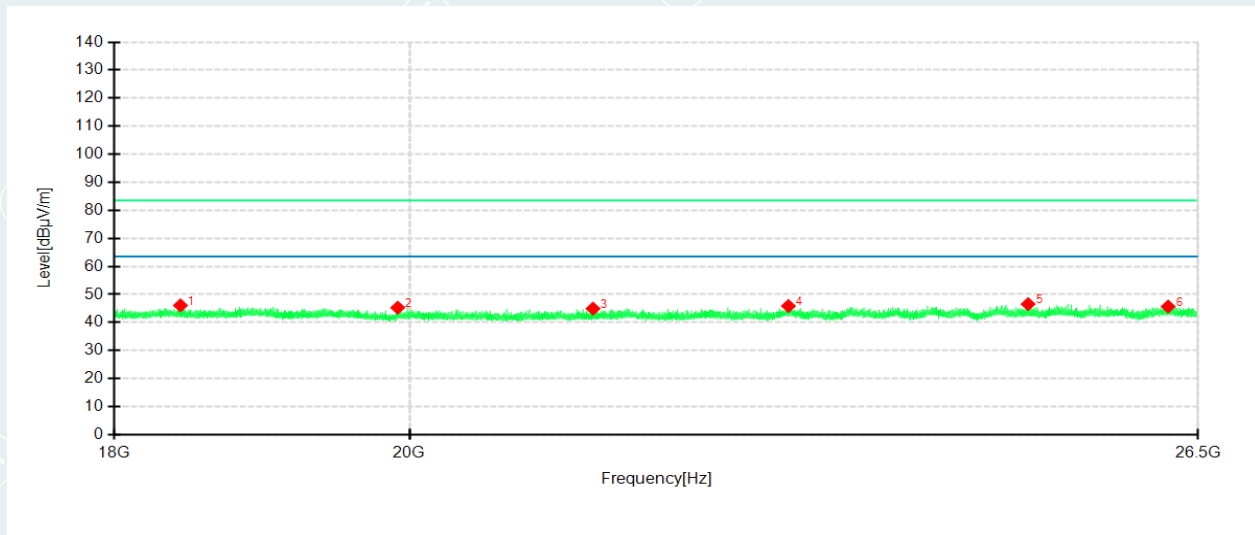

Suspected Data List									
NO.	Freq. [MHz]	Reading [dBμV/m]	Level [dBμV/m]	Factor [dB]	Limit [dBμV/m]	Margin [dB]	Height [cm]	Angle [°]	Polarity
1	18430.5250	57.59	46.08	-11.51	83.54	37.46	150	150	Vertical
2	19916.3250	56.15	45.29	-10.86	83.54	38.25	150	160	Vertical
3	21354.1000	55.07	44.93	-10.14	83.54	38.61	150	329	Vertical
4	22896.4250	54.87	45.87	-9.00	83.54	37.67	150	150	Vertical
5	24941.5250	54.50	46.55	-7.95	83.54	36.99	150	255	Vertical
6	26219.5000	53.56	45.68	-7.88	83.54	37.86	150	128	Vertical

Note:

- Radiated emissions measured in frequency range from 18GHz – 26.5GHz were made with an instrument using Peak/AV detector mode.
- According to C63.10, if the peak (or quasi-peak) measured value complies with the average limit, it's unnecessary to perform an average measurement.
- Above 18G test distance is 1m, so the Peak Limit= $74+20*\log(3/1)=83.54$ (dBμV/m), The limits are relaxed.
- The IF bandwidth of Receiver between above was 1MHz.
- After the X/Y/Z axis test, it is found that the X axis result is the worst, so only the X axis test results were recorded in the report.

6. Restricted bands

6.1 LIMITS

Radiated emissions which fall in the restricted bands, as defined in §15.205(a) of FCC part 15, must also comply with the radiated emission limits specified in §15.209(a).

MHz	MHz	MHz	GHz
0.090 - 0.110	16.42 - 16.423	1435 - 1626.5	4.5 - 5.15
0.495 - 0.505	16.69475 - 16.69525	1645.5 - 1646.5	5.35 - 5.46
2.1735 - 2.1905	16.80425 - 16.80475	1660 - 1710	7.25 - 7.75
4.125 - 4.128	25.5 - 25.67	1718.8 - 1722.2	8.025 - 8.5
4.17725 - 4.17775	37.5 - 38.25	2200 - 2300	9.0 - 9.2
4.20725 - 4.20775	73 - 74.6	2310 - 2390	9.3 - 9.5
6.215 - 6.218	74.8 - 75.2	2483.5 - 2500	10.6 - 12.7
6.26775 - 6.26825	108 - 121.94	2690 - 2900	13.25 - 13.4
6.31175 - 6.31225	123 - 138	3260 - 3267	14.47 - 14.5
8.291 - 8.294	149.9 - 150.05	3332 - 3339	15.35 - 16.2
8.362 - 8.366	156.52475 - 156.52525	3345.8 - 3358	17.7 - 21.4
8.37625 - 8.38675	156.7 - 156.9	3600 - 4400	22.01 - 23.12
8.41425 - 8.41475	162.0125 - 167.17		23.6 - 24.0
12.29 - 12.293	167.72 - 173.2		31.2 - 31.8
12.51975 - 12.52025	240 - 285		36.43 - 36.5
12.57675 - 12.57725	322 - 335.4		Above 38.6
13.36 - 13.41	399.9 - 410		
	608 - 614		
	960 - 1240		
	1300 - 1427		

All out of band emissions appearing in a restricted band as specified in Section 15.205 of the Title 47 CFR must exceed the limits shown in Table per Section 15.209.

FCC Part 15 Subpart C Paragraph 15.209		
Frequency (MHz)	Field strength (microvolt/meter)	Measurement distance (meters)
0.009-0.490	300/F(kHz)	300
0.490-1.705	24000/F(kHz)	30
1.705-30.0	30	30
30-88	100**	3
88-216	150**	3
216-900	200**	3
Above 960	500	3

6.2 TEST PROCEDURES

- 1) The EUT is placed on a turntable, which is 1.5m above the ground plane.
- 2) The turntable shall be rotated for 360 degrees to determine the position of maximum emission level.
- 3) EUT is set 3m away from the receiving antenna, which is varied from 1m to 4m to find out the highest emission.
- 4) Set the spectrum analyzer in the following setting in order to capture the lower and upper band-edges of the emission:
- 5) PEAK: RBW=1MHz / VBW=1MHz / Sweep=AUTO.
- 6) AVERAGE: RBW=1MHz / VBW=1/T / Sweep=AUTO.
- 7) If the EUT is configured to transmit with duty cycle $\geq 98\%$, set $VBW \leq RBW/100$ (i.e., 10kHz) but not less than 10 Hz.
- 8) If the EUT duty cycle is $< 98\%$, set $VBW \geq 1/T$, Where T is defined in section 5.4.
- 9) Repeat the procedures until all the PEAK and AVERAGE versus POLARIZATION are measured.

6.3 TEST SETUP

1GHz ~ 18GHz Test Setup.

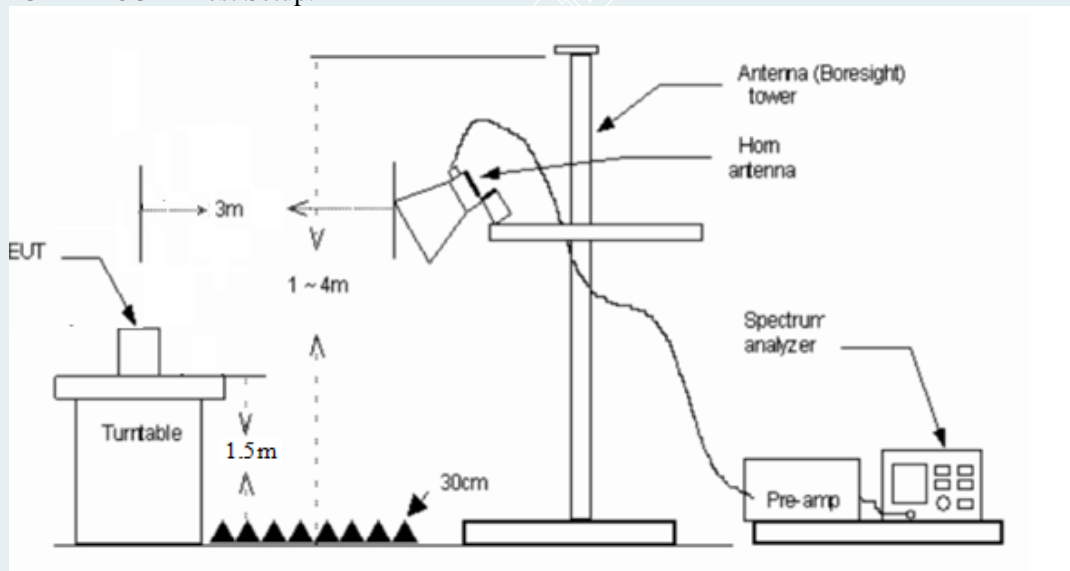

----- The following blanks -----

6.4 TEST RESULT

EUT Name	Wireless Module	Model	VT-ANT-257
Environmental Conditions	25°C/60%RH	Test Mode	Mode 1
Power supply	DC 3V	Tested By	Lu Qiang
Test Date	2022-04-02	Sample No.	E202204024904-0001
Frequency	2450 MHz	Detector mode	Peak

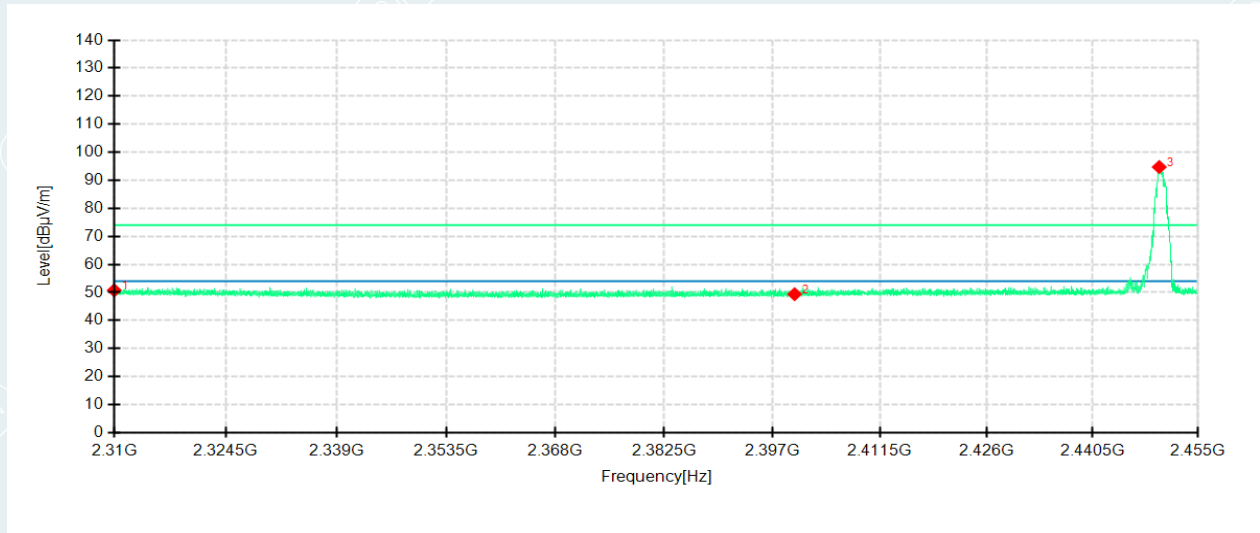

Suspected Data List

NO.	Freq. [MHz]	Reading [dBμV/m]	Level [dBμV/m]	Factor [dB]	Limit [dBμV/m]	Margin [dB]	Height [cm]	Angle [°]	Polarity
1	2310.0000	46.82	50.75	3.93	74.00	23.25	200	202	Horizontal
2	2400.0000	46.20	49.38	3.18	74.00	24.62	200	202	Horizontal
3	2449.6640	91.06	94.73	3.67	74.00	-20.73	100	254	Horizontal

Note:

1. The Peak test was carried out, and the Peak value met the AVG limit value, so there was no need to test AVG

EUT Name	Wireless Module	Model	VT-ANT-257
Environmental Conditions	25°C/60%RH	Test Mode	Mode 1
Power supply	DC 3V	Tested By	Lu Qiang
Test Date	2022-04-02	Sample No.	E202204024904-0001
Frequency	2450 MHz	Detector mode	Peak

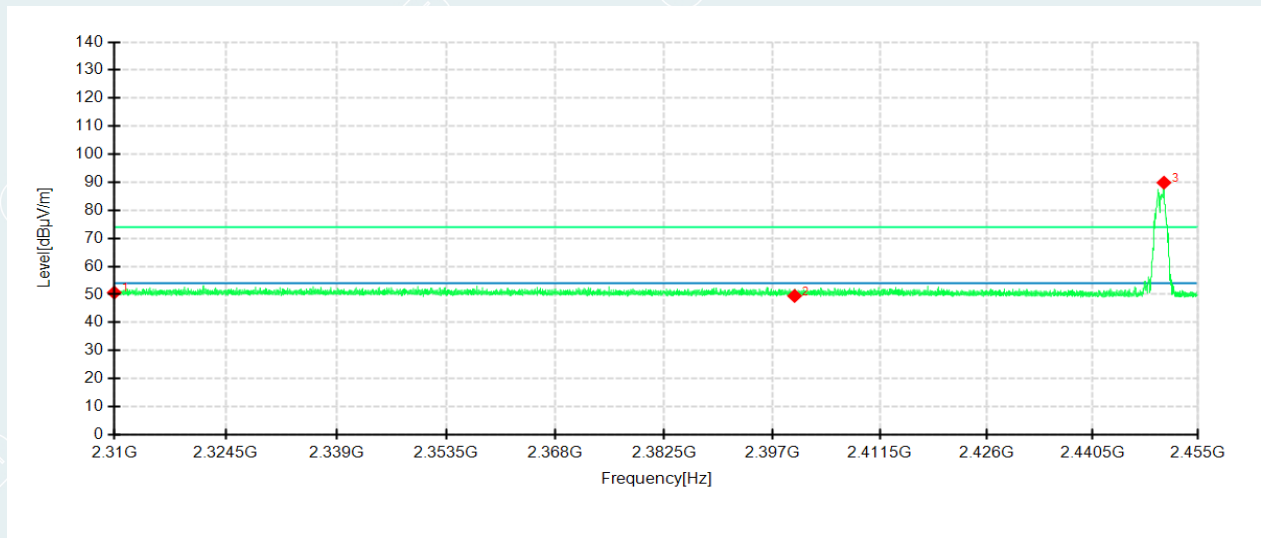

Suspected Data List									
NO.	Freq. [MHz]	Reading [dBµV/m]	Level [dBµV/m]	Factor [dB]	Limit [dBµV/m]	Margin [dB]	Height [cm]	Angle [°]	Polarity
1	2310.0000	46.14	50.65	4.51	74.00	23.35	100	202	Vertical
2	2400.0000	45.28	49.46	4.18	74.00	24.54	200	344	Vertical
3	2450.3165	86.29	89.86	3.57	74.00	-15.86	200	263	Vertical

Note:

1. The Peak test was carried out, and the Peak value met the AVG limit value, so there was no need to test AVG

EUT Name	Wireless Module	Model	VT-ANT-257
Environmental Conditions	25°C/60%RH	Test Mode	Mode 1
Power supply	DC 3V	Tested By	Lu Qiang
Test Date	2022-04-02	Sample No.	E202204024904-0001
Frequency	2457 MHz	Detector mode	Peak

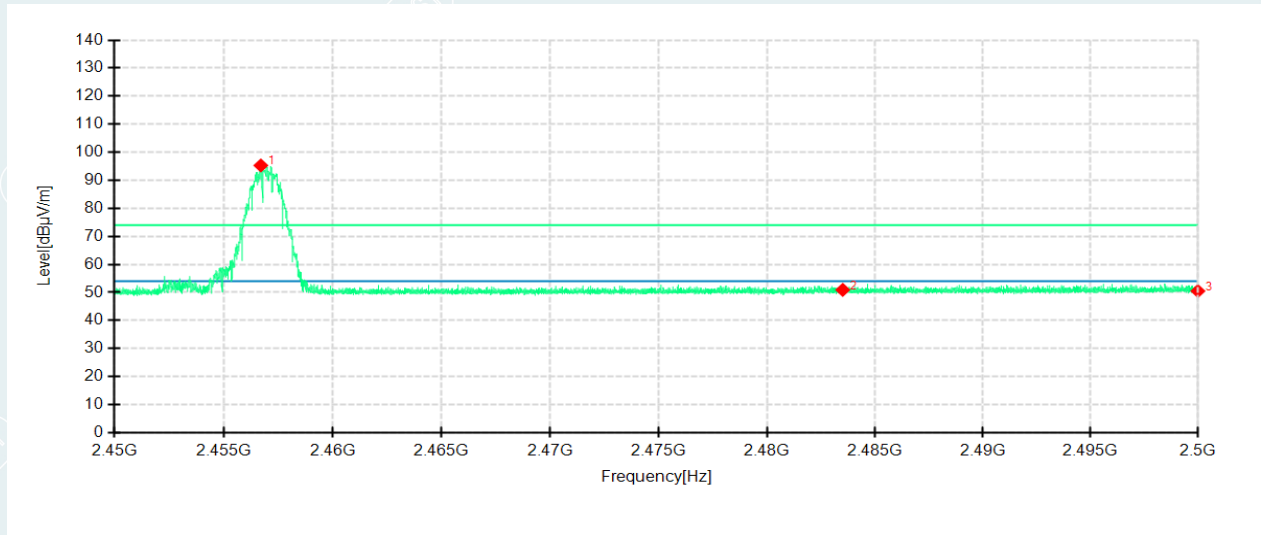

Suspected Data List									
NO.	Freq. [MHz]	Reading [dBµV/m]	Level [dBµV/m]	Factor [dB]	Limit [dBµV/m]	Margin [dB]	Height [cm]	Angle [°]	Polarity
1	2456.7050	91.49	95.29	3.80	74.00	-21.29	100	253	Horizontal
2	2483.5000	46.58	50.91	4.33	74.00	23.09	100	156	Horizontal
3	2500.0000	45.85	50.50	4.65	74.00	23.50	200	203	Horizontal

Note:

1. The Peak test was carried out, and the Peak value met the AVG limit value, so there was no need to test AVG

EUT Name	Wireless Module	Model	VT-ANT-257
Environmental Conditions	25°C/60%RH	Test Mode	Mode 1
Power supply	DC 3V	Tested By	Lu Qiang
Test Date	2022-04-02	Sample No.	E202204024904-0001
Frequency	2457 MHz	Detector mode	Peak

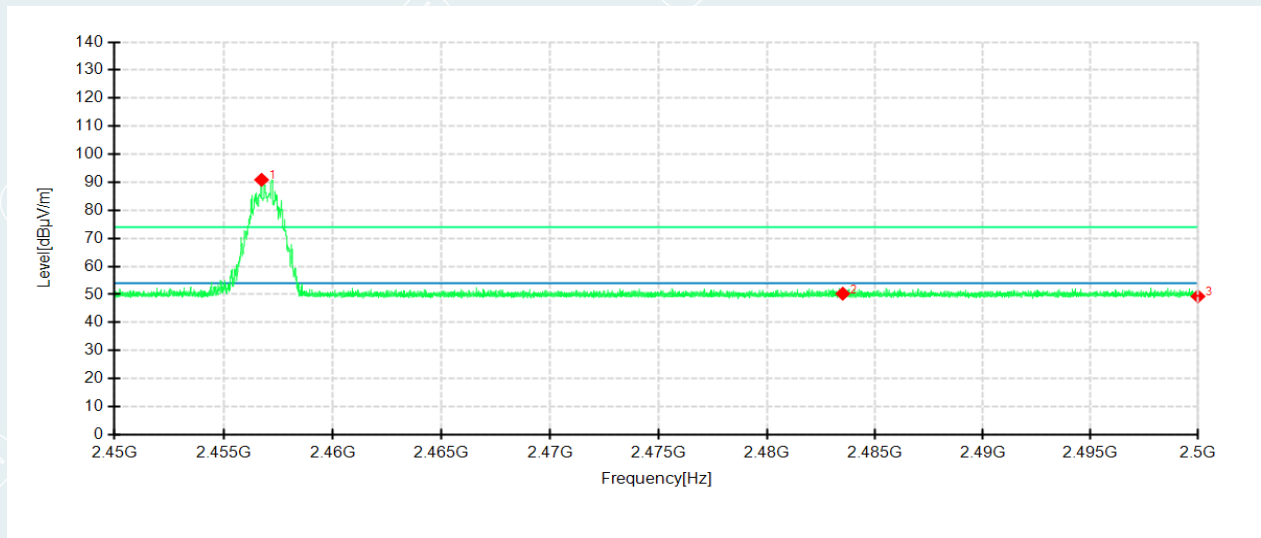

Suspected Data List									
NO.	Freq. [MHz]	Reading [dBµV/m]	Level [dBµV/m]	Factor [dB]	Limit [dBµV/m]	Margin [dB]	Height [cm]	Angle [°]	Polarity
1	2456.7400	87.28	90.87	3.59	74.00	-16.87	200	260	Vertical
2	2483.5000	46.57	50.26	3.69	74.00	23.74	100	69	Vertical
3	2500.0000	45.55	49.30	3.75	74.00	24.70	100	203	Vertical

Note:

1. The Peak test was carried out, and the Peak value met the AVG limit value, so there was no need to test AVG

7. 20dB BANDWIDTH

7.1 LIMITS

The test of the item was performed in accordance with the standards §15.215(c).

7.2 TEST PROCEDURES

- 1) Remove the antenna from the EUT, and then connect a low loss RF cable from antenna port to the spectrum analyzer.
- 2) Spectrum analyzer setup as per :The nominal IF filter bandwidth (3 dB RBW) shall be in the range of 1% to 5% of the OBW and video bandwidth (VBW) shall be approximately three times RBW.
- 3) Set the spectrum analyzer as Span>Declare bandwidth, Sweep = auto.
- 4) Record 20dB of the bandwidth value.
- 5) Repeat above procedures until all frequencies measured were complete.

7.3 TEST SETUP



7.4 TEST RESULTS

Channel	Frequency (MHz)	20dB Bandwidth (MHz)	Test Result
Low	2450	1.036	PASS
High	2457	1.036	PASS

----- The following blanks -----

EUT Name	Wireless Module	Model	VT-ANT-257
Environmental Conditions	25°C/60%RH	Test Mode	Mode 1
Power supply	DC 3V	Tested By	Lu Qiang
Test Date	2022-04-02	Sample No.	E202204024904-0002
Frequency	2450 MHz	/	/



EUT Name	Wireless Module	Model	VT-ANT-257
Environmental Conditions	25°C/60%RH	Test Mode	Mode 1
Power supply	DC 3V	Tested By	Lu Qiang
Test Date	2022-04-02	Sample No.	E202204024904-0002
Frequency	2457 MHz	/	/



8. APPENDIX A. PHOTOGRAPH OF THE TEST CONNECTION DIAGRAM

Please refer to the attached document E202204024904-5-Test setup photo.

----- **The following blanks** -----



9. APPENDIX B. PHOTOGRAPH OF THE EUT

Please refer to the attached document E202204024904-6-EUT Photo.

----- End of Report -----

