

Engine Fuel System and Power Rating

Fuel System

IMPORTANT: Modification or alteration of injection system or emission control devices will terminate warranty to purchaser.

Do not attempt to service injection system. Special training and special tools are required. See your John Deere™ dealer.

John Deere is a trademark of Deere & Company

Engine Certification/Power Rating

kW (hp) rating on engine emissions certification label specifies gross engine kW (hp), which is flywheel power without fan.

TO84419,00000BC -19-27NOV12-1/1

Battery Disconnect (If Equipped)

CAUTION: Never turn off power on the battery disconnect switch while the engine is running. This could result in serious damage to the tractor electrical components.

IMPORTANT: During a long storage period, always turn battery disconnect switch to OFF position. The battery could lose power if the battery disconnect switch is left ON.

(Final Tier 4 and Stage IV Engines only.) To determine which engine your tractor is equipped with, see Record Engine Serial Number in Identification Numbers section of this Operator's Manual. Do not disconnect battery until Selective Catalyst Reduction (SCR) system has had enough time to automatically purge system of Diesel Exhaust Fluid (DEF). If adequate time is not allowed for system to be purged, any DEF remaining can crystallize and plug system. At temperatures below -15°C (5°F), unpurged DEF will freeze and damage system components. If equipped with a battery disconnect system, a light next to disconnect system is illuminated while auto-purge is in progress. It shuts off when complete and safe to disconnect the battery. If tractor is not equipped with battery disconnect, wait at least 4 minutes after tractor stops before disconnecting battery.

IMPORTANT: Final Tier 4/Stage IV tractor battery disconnect system is equipped with a warning light. Do not move battery disconnect switch to "OFF" position until the light goes out. Illuminated light indicates SCR system is in process of draining DEF. Full DEF drain process can take up to 4 minutes.

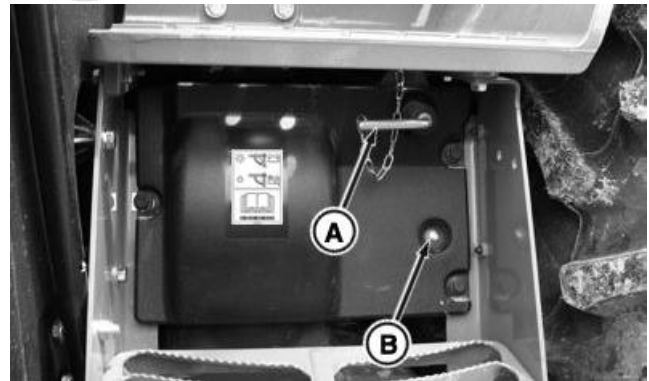

Battery Disconnect Switch "ON"

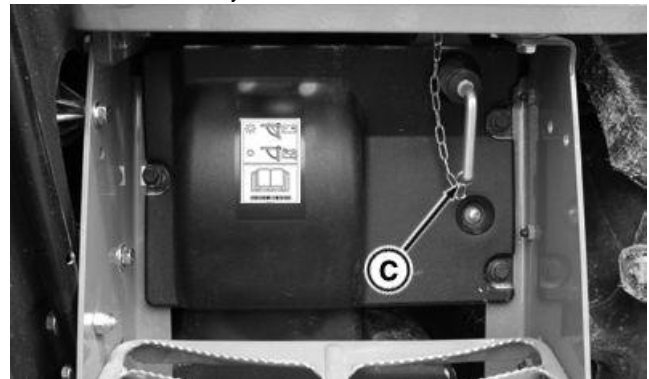

Battery Disconnect Switch "OFF"

- A—Battery Disconnect Switch Lever "ON"
- B—DEF Indicator Light (Final Tier IV Only)
- C—Battery Disconnect Switch Lever "OFF"

When battery disconnect switch lever is in "OFF" (A) position, batteries are electrically disconnected from tractor electrical and electronic systems. Moving switch to "ON" (B) position reconnects batteries into system.

RW29387,0000645 -19-03SEP13-1/1

RXA0133425—UN—28JUN13

RXA0133426—UN—28JUN13

Starting the Engine

⚠ CAUTION: Avoid possibility of personal injury or death. Engine starting with shift lever in gear indicates malfunction of starting circuit. Repairs should be made immediately by your John Deere™ dealer.

Do not start engine by shorting across starter terminals. Tractor will start in gear if normal circuitry is bypassed. Start engine **ONLY** from operator seat.

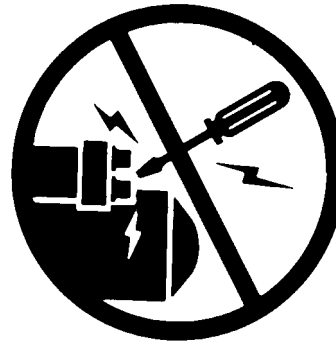

Before Starting Tractor

1. Move SCV levers to NEUTRAL position.
2. Disengage PTO.
3. Move hand throttle to slow idle position.
4. Move transmission shift lever to PARK position.

⚠ CAUTION: Avoid possibility of serious injury or death. Be sure tractor and attached equipment are clear of people and other objects.

5. Depress clutch and brake pedals.
6. Sound horn.
7. Turn key switch (A) to engage starter. Release key when engine starts.

IMPORTANT: Avoid starter damage. Do not operate starter more than 30 seconds. Wait at least two minutes before trying again.



If Engine Fails To Start:

Check quantity and quality of fuel.

Check electrical system.

In cold weather (at or below -6 °C (21 °F)), follow steps listed in appropriate Cold Weather Starting topic in this section of this Operator's Manual.

Engine speed is limited to 1500 rpm based on transmission type and transmission-hydraulic oil temperature:

*John Deere is a trademark of Deere & Company
 IVT is a trademark of Deere & Company
 AutoPowr is a trademark of Deere & Company
 PowrShift is a trademark of Deere & Company*

A—Key Switch

IVT™ /AutoPowr™ - temperature below -5 °C (23 °F).

PowrShift™ transmission- temperature below -18 °C (0 °F).

If engine fails to start after three attempts, it may be necessary to consult John Deere™ service technician.

TS177—UN—11JAN89

RXA0129144—UN—30OCT12

TO84419,00000BD -19-03SEP13-1/1

Running the Engine

Do not start engine with throttle pushed completely forward.

Avoid excessive engine idling (more than 5 minutes). Prolonged idling may cause engine coolant temperature to fall below normal range. Prolonged idling causes crankcase oil dilution, due to incomplete fuel combustion, and permits formation of gummy deposits on valves, pistons, and piston rings. It promotes rapid accumulation of engine sludge and unburned fuel in exhaust system.

Operate engine between 1500—2100 rpm. Do not operate engine constantly below 1500 rpm during heavy draft usage or when tractor is under full PTO load.

For maximum tractor performance:

- Ensure that tractor is correctly ballasted (see Performance Ballasting section of this Operator's Manual).
- For e23™ transmission, see e23™ Transmission section of this Operator's Manual.

- For IVT™/AutoPowr™ transmission, see IVT™/AutoPowr™ Transmission section of this Operator's Manual..

If engine stalls, start immediately to provide lubrication to critical engine parts.

Allow engine to idle for 20 seconds before turning ignition to off position.

Contact your John Deere™ dealer if any symptoms that may be early signs of engine problems are detected:

- Sudden drop in oil pressure
- Abnormal coolant temperatures
- Unusual noise or vibration
- Sudden loss of power
- Excessive fuel consumption
- Excessive oil consumption
- Fluid leaks

TO84419,00000BE -19-22JUL13-1/1

Stopping the Engine

IMPORTANT: Before stopping an engine that has been operating at working load, idle engine at least 2 minutes at 1000—1200 rpm to cool hot engine parts. If an Exhaust Filter Cleaning has just been performed, increase engine idle time to 4 minutes. If service work is going to be performed on Exhaust Filter, increase engine idle time to 10 minutes.

IMPORTANT: Final Tier 4 and Stage IV Engines only: To determine which engine your tractor is equipped with, see Record Engine Serial Number in Identification Numbers section of this Operator's Manual. Do not disconnect battery until Selective Catalyst Reduction (SCR) system has had enough time to automatically purge system of Diesel Exhaust Fluid (DEF). If adequate time is not allowed for system to be purged, any DEF remaining can crystallize and plug system. At temperatures below -15°C (5°F), unpurged DEF will freeze and damage system components. If equipped with a battery disconnect system, a light next to disconnect

system is illuminated while auto-purge is in progress. It shuts off when complete and safe to disconnect the battery. If tractor is not equipped with battery disconnect, wait at least 4 minutes after tractor stops before disconnecting battery.

1. Pull throttle back to slow idle position.
2. Depress clutch and brake pedals.
3. Put transmission in PARK position.
4. Lower all equipment to ground.
5. Make sure SCV levers are in NEUTRAL position.
6. Make sure PTO lever is disengaged.
 - Pull PTO clutch lever rearward to disengage clutch (if equipped).

CAUTION: Remove ignition switch key to help prevent accidents.

7. Turn ignition key to OFF position and remove key.

RX32825,000074E -19-03SEP13-1/1

Cold Weather Starting—Equipped With Glow Plug Starting Aid (6.8 L Engines)

IMPORTANT: To determine with which engine type tractor is equipped, see Record Engine Serial Number in Identification Numbers Section of this Operator's Manual.

IMPORTANT: DO NOT use starting fluid on tractors equipped with glow plugs.

Use of starting fluid on engines with glow plugs can cause pre-detonation when contacting heater components. Engine damage may result.

NOTE: All 6.8 L engines are equipped with glow plugs. Glow plugs are protected by 50 Amp harness in-line fuse.

Use of glow plugs is recommended when cold weather when temperature is at or below -6 °C (21 °F).

1. Turn key switch to RUN position.
2. Engine Preheat Indicator (A), on Corner Post, will illuminate when system is activated.
3. Display will start at 15 seconds or less, depending on temperature, and count down until to zero (see table below).
4. At 0, turn key switch to start engine.
5. If engine does not start, return key to OFF position and repeat steps 1-4.

If Engine Fails to Start:

Check quantity and quality of fuel.

Check electrical system.

If engine fails to start after three attempts, it may be necessary to consult your John Deere™ dealer.

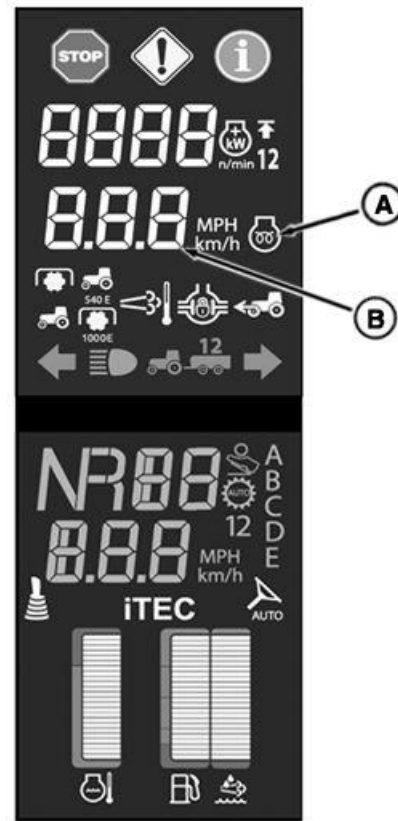

Corner Post Display

A—Engine Preheat Indicator B—Glow Plug Wait Time

Intercooler Outlet Temperature	Wait Time (Seconds)
-15 °C (5 °F)	15
-10 °C (14 °F)	10
-5 °C (23 °F)	5
0 °C (32 °F)	5
5 °C (41 °F)	2
8 °C (46 °F)	0

Wait Time Depending on Intercooler Outlet Temperature

RW29387,00006A3 -19-29AUG13-1/1

RXA0135050—JUN—14AUG13

Cold Weather Starting—Without Optional Starting Aid (9.0 L Engines)

⚠ CAUTION: Starting fluid is highly flammable. While using this product do not smoke and make sure to extinguish all flames. Turn off all pilot lights, stoves, heaters, electrical motors, and other sources of ignition while using this product and/or if vapors are still present. Avoid contact of aerosol with battery terminals, solenoid, or other electrical/electronic components. Do not overuse this product. Keep cap on container and store in cool location when not in use.

NOTE: Use of starter fluid is recommended when starting tractor at or below -6°C (21°F) (See *Cold Weather Starting—With Starting Aid* in this section of this Operator's Manual).

A cold weather starting kit is available from your John Deere dealer.

1. Spray starting fluid into air intake screen (A) once for two or three seconds.
2. Follow steps as outlined in Starting the Engine in this section of this Operator's Manual.

If Engine Fails to Start:

Check quantity and quality of fuel.

Check electrical system.

If engine fails to start after three attempts, it may be necessary to consult your John Deere™ dealer.



A—Air Intake Screen

TS1356 —UN—18MAR92

RXA0128561 —UN—18OCT12

TO84419,00000C0 -19-22JUL13-1/1

P
R
O
O
F

Cold Weather Starting—With Starting Aid (9.0 L Engines—If Equipped)

CAUTION: Avoid personal injury and damage to engine. Inject fluid only while engine is turning. Follow safety information on the container. Do not carry starting fluid cans inside cab.

Starting fluid is highly flammable. While using this product do not smoke and make sure to extinguish all flames. Turn off all pilot lights, stoves, heaters, electrical motors, and other sources of ignition while using this product and/or if vapors are still present. Avoid contact of aerosol with battery terminals, solenoid, or other electrical/electronic components. Do not overuse this product. Keep cap on container and store in cool location when not in use.

NOTE: Use of cold weather starting option is recommended when starting tractor at or below -6 °C (21 °F).

1. Start tractor as described in Starting the Engine in this section of this Operator's Manual.

IMPORTANT: Avoid starter damage. Do not operate starter more than 30 seconds. Wait at least two minutes before trying again.

When applying starter fluid, if pre-ignition knocking is detected, stop using starter fluid immediately.

2. Following are recommendations to follow if engine refuses to start. Make sure to turn ignition key and complete following steps while engine is cranking:
 - Apply starter fluid in series of quick taps rather than stream.

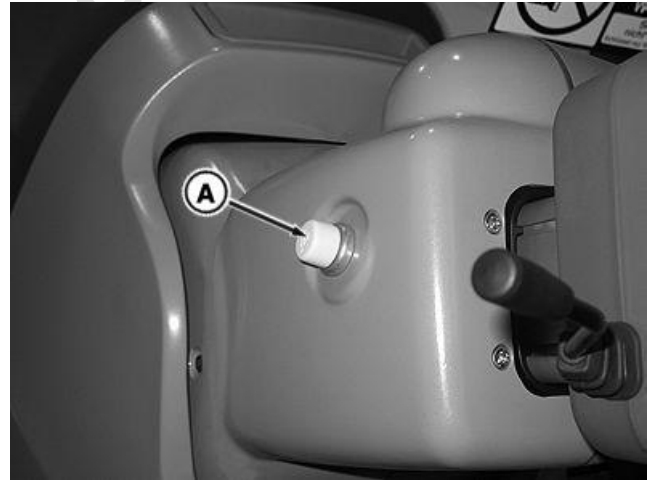

A—Starting Fluid Switch

- After series of taps (no more than three) on starter fluid button (A) release starter fluid button for three seconds.
- If engine attempts to start but falters, use tapping motion on starter fluid button sparingly and only until engine runs on its own.

IMPORTANT: Idle engine at approximately 1000 rpm with no load for one to two minutes to assure adequate lubrication. Do not operate under full load until engine has reached normal operating temperature.

RXA0129150—UN—05NOV12

KT81203,000000E -19-22JUL13-1/1

Changing Starting Fluid Can (If Equipped)

CAUTION: Do not use starting fluid near fire, sparks, or flames. Read caution information on container. Protect container against damage. Do not carry starting fluid canisters inside cab.

1. Pull hood release and raise hood to access canister (A).
2. Remove safety cap and plastic spray nozzle from new canister.
3. Loosen canister and remove old can.

IMPORTANT: To avoid drawing dust into engine, always keep starting fluid canister installed bottom side up, clean and in position.

4. Install new can and tighten canister.

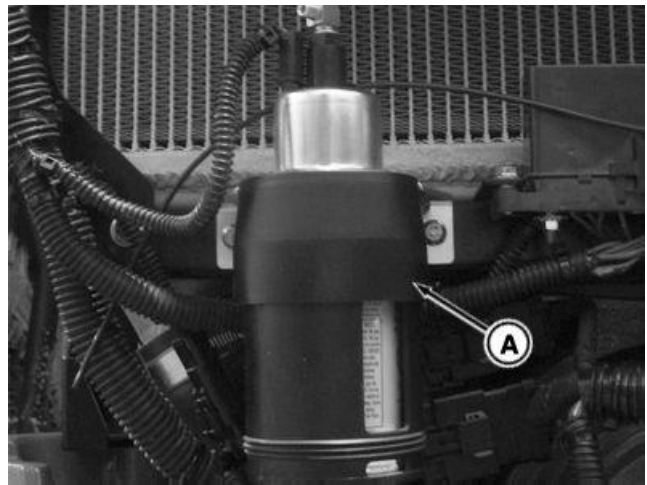

Right-Hand Side

A—Canister

RXA0135276 —UN—28AUG13

TO84419,00000C1 -19-27AUG13-1/1

Low Fuel or Low Diesel Exhaust Fluid (DEF) Warning

Fuel indicator light (A) will flash and alarm will sound when approximately 39 L (10 gal) of fuel remains.

DEF light (B) will flash and alarm will sound when fluid level is low.

NOTE: It is recommended that DEF tank be filled at each fuel tank fill.

A—Fuel Indicator Light

B—Diesel Exhaust Fluid (DEF) Light



Fuel Indicator Light

RXA0129257 —UN—31OCT12

TO84419,00000C2 -19-06SEP13-1/1

Restarting Engine That Has Run Out of Fuel

1. Fill fuel tank.
2. Turn key switch to RUN position to start electric fuel pump and bleed air from fuel system.
3. Allow pump to run for 30 seconds to 1 minute before attempting to restart engine.

Fuel pump will turn off after 1 minute. Key switch must be turned to OFF and back to RUN to turn pump back on.

NOTE: Steps two and three may need to be repeated as necessary if fuel tanks have been removed or drained.

TO84419,00000C3 -19-06SEP13-1/1

Reduce Fuel Consumption

Following are guidelines to reduce fuel consumption:

- Replace air cleaner, fuel, engine oil, and transmission-hydraulic filter elements at specified service intervals (see Maintenance and Service Intervals section) or when indicated by CommandCenter™ display messages.
- Use recommended oils and lubricants only (see Fuel, Lubricants, and Coolant section of this Operator's Manual).
- Adjust hitch function for most efficient operation (see TouchSet Depth Control section of this Operator's Manual).
- Check tires for correct pressure weekly (see Front or Rear Wheels, Tires, and Treads section of the Operator's Manual).
- Ballast tractor for conditions (see Performance Ballasting section of this Operator's Manual).

*CommandCenter is a trademark of Deere & Company
FieldCruise is a trademark of Deere & Company
IVT is a trademark of Deere & Company
AutoPowr is a trademark of Deere & Company*

- For gear transmissions, select correct gear. Always drive in highest possible gear with reduced engine speed. Choose gear so engine speed drops 150-250 rpm when tractor is operating and engine is under load (see appropriate transmission section of this Operator's Manual).

NOTE: For light work, reduce engine speed below 2000 rpm. Select gear so that engine speed drops 200—300 rpm when operating.

Using FieldCruise™ may improve fuel economy (see Using FieldCruise™ in Operating the Tractor section of this Operator's Manual).

- IVT™ /AutoPowr™ transmissions provide additional fuel saving advantages (see IVT/AutoPowr™ section of this Operator's Manual).

TO84419,00000C4 -19-06SEP13-1/1

Using Auxiliary Heaters

CAUTION: To avoid electrical shock or fire, use 3-wire, 14 AWG (14 gauge), heavy-duty electrical cord with 15 amp rating, suitable for outdoor use. Always plug electrical cord into outlet protected by GFI (Ground Fault Interrupter).

Before connecting heater to power source, be sure that element is immersed in coolant. NEVER energize heater in air. Doing so can cause element sheath to burst causing personal injury.

IMPORTANT: Ground fault circuit interrupter on tractor protects tractor only, not electrical wiring supplying power to tractor. Test all ground fault interrupters before each use.

Your John Deere™ dealer has ground fault interrupter-equipped heaters¹:

- Engine Coolant (1000 W)
- Transmission (200 W)
- Hydraulic Charge Pump (200 W)

Connect heaters and ground fault interrupter to ground fault protected 120-volt electrical outlet.

John Deere is a trademark of Deere & Company

¹Includes a ground fault interrupter

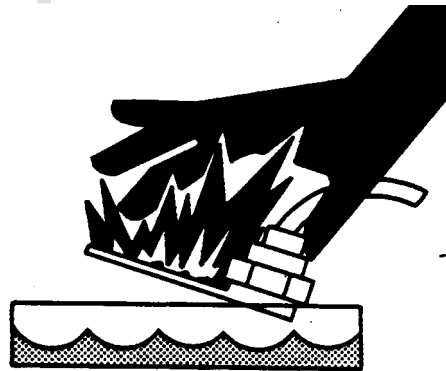

TS210 —UN—23AUG88

RXA0129146 —UN—30OCT12

TO84419,00000C5 -19-23JUL13-1/1

Using a Battery Booster or Charger

CAUTION: Gas given off by batteries is explosive. Keep sparks and flames away from batteries. Make last connection and first disconnection at point away from booster batteries.

CAUTION: Avoid possible injury or death from machinery runaway.

Do not start engine by shorting across starter terminals. Machine will start in gear if normal circuitry is bypassed.

NEVER start engine while standing on ground. Start engine only from operator's seat, with transmission in neutral or park.

IMPORTANT: Be sure that polarity is correct before making connections. Reversed polarity will damage electrical system or possibly cause battery to explode.

If two or more booster batteries are used, they must be connected in parallel ensuring that booster batteries are producing 12 volt charge.

Final Tier 4 and Stage IV Engines only: To determine which engine your tractor is equipped with, see Record Engine Serial Number in Identification Numbers section of this Operator's Manual. Do not disconnect battery until Selective Catalyst Reduction (SCR) system has had enough time to automatically purge system of Diesel Exhaust Fluid (DEF). If adequate time is not allowed for system to be purged, any DEF remaining can crystallize and plug system. At temperatures below -15°C (5°F), unpurged DEF will freeze and damage system components. If equipped with a battery disconnect system, a light next to disconnect system is illuminated while auto-purge is in progress. It shuts off when complete and safe to disconnect the battery. If tractor is not equipped with battery disconnect, wait at least 4 minutes after tractor stops before disconnecting battery.

Booster Battery

1. Attach red cable to remote positive terminal (A) of starter and positive terminal of booster battery.
2. Attach black cable to negative terminal of booster battery. Attach other end to ground (B) on tractor frame.

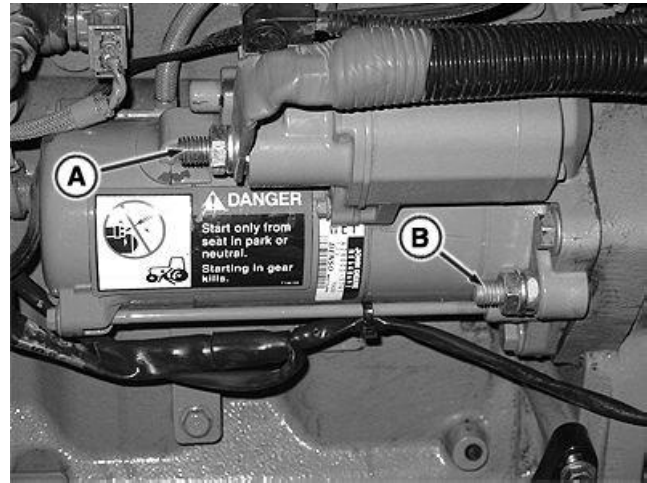
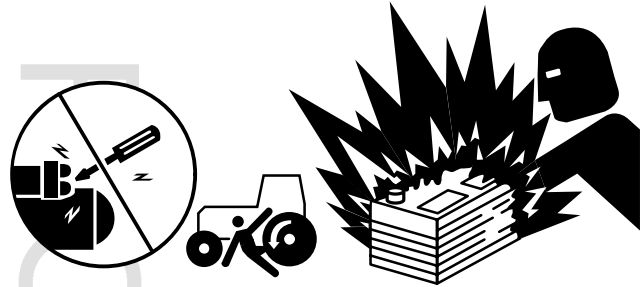

A—Positive Terminal

B—Ground

3. Remove ground cable first when disconnecting.

Battery Charger

IMPORTANT: Set battery charger at nominal 12 volt and no more than 16 volt maximum.

1. Attach positive charger lead to positive remote terminal with charger in OFF position. Attach negative charger lead to negative ground at tractor frame, away from batteries.
2. Switch charger to ON and charge battery according to charger manufacturer's instructions.
3. Switch charger to OFF. Remove negative charger lead first, then positive lead.

TO84419,00000C6 -19-03SEP13-1/1

RXA0086722—UN—10FEB06

RXA0129147—UN—30OCT12

Operating the Tractor

Avoid Contact with Agricultural Chemicals

⚠ CAUTION: This enclosed cab does not protect against inhaling vapor, aerosol or dust.

1. When operating in an environment where pesticides are present, wear a long-sleeved shirt, long-legged pants, shoes, and socks.
2. If pesticide use instructions require respiratory protection, wear an appropriate respirator inside the cab.
3. Wear personal protective equipment as required by the pesticide use instructions when leaving the enclosed cab:
 - into a treated area
 - to work with contaminated application equipment such as nozzles which must be cleaned, changed or redirected
 - to become involved with mixing and loading activities
4. Before re-entering the cab, remove protective equipment and store either outside the cab in a closed box or some other type of sealable container or inside the cab in a pesticide resistant container, such as a plastic bag.
5. Clean your shoes or boots to remove soil or other contaminated particles prior to entering the cab.

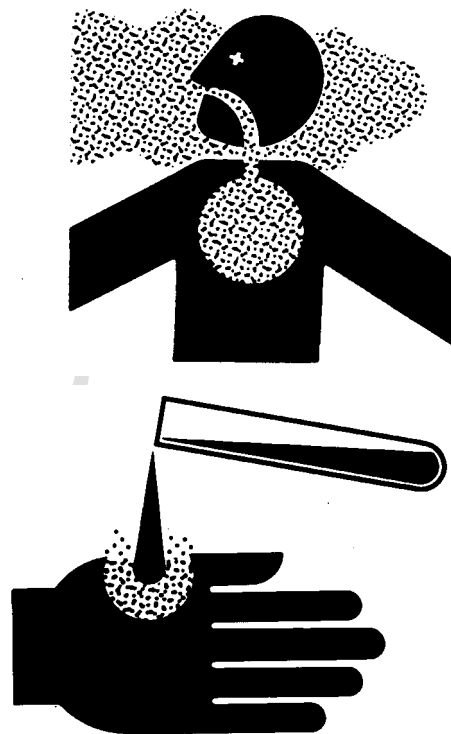

TS220 —UN—15APR13

TS272 —UN—23AUG88

DX,CABS1 -19-25MAR09-1/1

Clean Vehicle of Hazardous Pesticides

⚠ CAUTION: During application of hazardous pesticides, pesticide residue can build up on the inside or outside of the vehicle. Clean vehicle according to use instructions of hazardous pesticides.

When exposed to hazardous pesticides, clean exterior and interior of vehicle daily to keep free of the accumulation of visible dirt and contamination.

1. Sweep or vacuum the floor of cab.
2. Clean headliners and inside cowlings of cab.
3. Wash entire exterior of vehicle.
4. Dispose of any wash water with hazardous concentrations of active or non-active ingredients according to published regulations or directives.

DX,CABS2 -19-24JUL01-1/1

Keep Riders Off Machine

Only allow the operator on the machine. Keep riders off.

Riders on machine are subject to injury such as being struck by foreign objects and being thrown off of the machine. Riders also obstruct the operator's view resulting in the machine being operated in an unsafe manner.

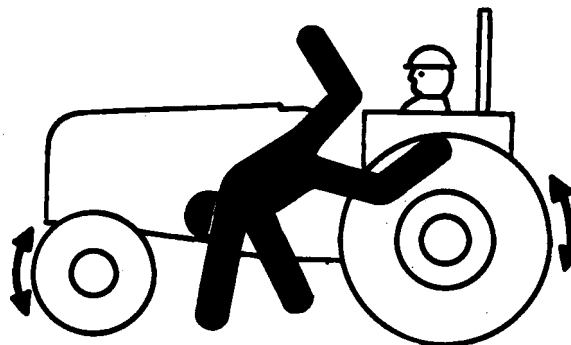

TS290 —UN—23AUG88

DX,RIDER -19-03MAR93-1/1

Keep Operator Station Window and Door Closed

CAUTION: Avoid undue exposure to noise and debris. Keep window and door closed during machine operation.

Make sure that window and door are properly closed and latched to prevent noise or debris from entering operator station.

RW29387,000004F -19-06SEP13-1/1

Using Seat Belts

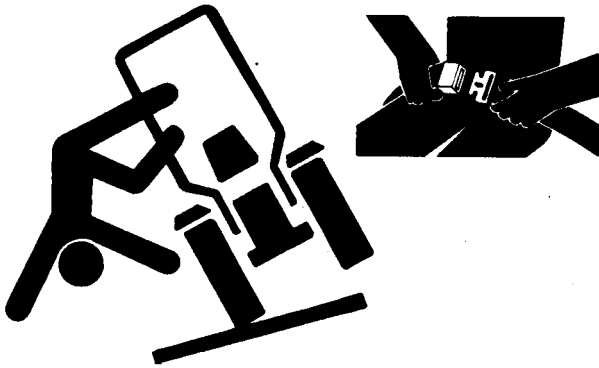

T5205—JUN—29AUG88



RXA0129149—JUN—30OCT12

Optional Instructional Seat Shown

A—Seat Belts

CAUTION: Minimize chance of possible injury from accident. Use seat belts (A) when operating tractor.

Instructional seat is provided only for training operators or diagnosing machine problems.

Keep all other riders off tractor and equipment. Always wear your seat belt.

Inspect seat belts and mounting hardware annually (see Annual Service section of this Operator's Manual).

TO84419,00000CA -19-23JUL13-1/1

Using Emergency Exit

Removable rear cab window provides large exit path if cab door is blocked in emergency situation.

To open window, lift lever (A) and push out glass.

A—Window Lever

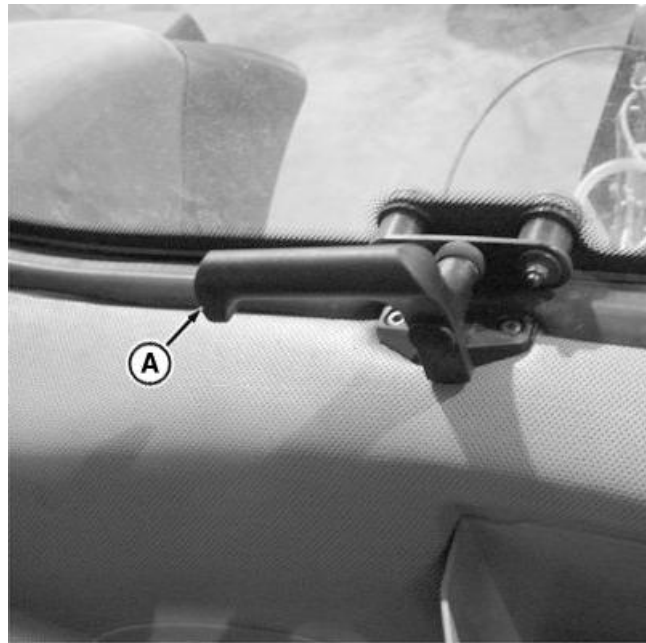

RXA0108246—UN—28JUN10

TO84419,00000CB -19-29NOV12-1/1

Disconnect Battery - Final Tier 4 and Stage IV Engines

IMPORTANT: To determine with which engine type tractor is equipped, see Record Engine Serial Number in Identification Numbers Section of this Operator's Manual.

IMPORTANT: Do not disconnect battery until Selective Catalyst Reduction (SCR) system has had enough time to automatically purge system of Diesel Exhaust Fluid (DEF). If adequate time is

not allowed for system to be purged, any DEF remaining can crystallize and plug system. At temperatures below -15°C (5°F), unpurged DEF will freeze and damage system components. If equipped with a battery disconnect system, a light next to disconnect system is illuminated while auto-purge is in progress. It shuts off when complete and safe to disconnect the battery. If tractor is not equipped with battery disconnect, wait at least 4 minutes after tractor stops before disconnecting battery.

RX32825,000074F -19-03SEP13-1/1

Paths to Important CommandCenter™ Pages

A—Sequence to SCV Page
B—Sequence to Engine Page

C—Sequence to Suspension Page

RXA0127861—UN—28AUG12



Menu → Tractor Settings Tab → SCV Icon

RXA0127862—UN—28AUG12



Menu → Tractor Settings Tab → Engine Icon

RXA0127863—UN—28AUG12



Menu → Tractor Settings Tab → Suspension Icon

TO84419,00000CD -19-26JUL13-1/1

Changing to a Different Size of Tire

IMPORTANT: Before changing size of tire, see Exchanging Tire Sizes in Front or Rear

Wheels, Tires, and Treads section of this Operator's Manual.

RW29387,0000629 -19-25JUL13-1/1

Transmission - Note on Top Speed

All three transmissions can be manually programmed to limit top speed through a dealer. Tractors programmed for 50 km/h (31 mph) top speed can be permanently downrated to 40 km/h (25mph) top speed. This may be advisable, if particular legal requirements for 50 km/h tractors cannot be met. Examples include a different class of driver's license, or similar restrictions. If top speed is changed, this must be recorded in the vehicle documents.

For more information, contact your John Deere™ dealer.

NOTE: It is only possible to uprate the tractor from 40 km/h (25 mph) to 50 km/h (31 mph) if tractor was equipped for 50 km/h before leaving the factory.

RW29387,000062A -19-29AUG13-1/1

Warm-Up Transmission-Hydraulic System

Set Detent Time

IMPORTANT: Avoid operating tractor under load until transmission-hydraulic system has warmed up. Tractor-hydraulic warm-up procedure is recommended at temperatures at or below $-5\text{ }^{\circ}\text{C}$ ($23\text{ }^{\circ}\text{F}$).

1. Install jumper hose (A) into SCV I couplers.
2. Ensure that transmission is in PARK position before starting tractor.
3. Select **Menu**.
4. Select **Tractor Settings** tab.
5. Select **SCV** icon.
6. Select SCV I display.
7. Select SCV I Time tab (B).
8. Select increase (+) button (C) to extend flow time to C (continuous) in input box (D). Adjustment dial (G) can also be used to increase or decrease desired detent time setting.

- | | |
|--------------------------|-------------------------|
| A— Jumper Hose | E— Decrease Time button |
| B— SCV I Detent Time Tab | F— SCV I Lever |
| C— Increase Time button | G— Adjustment Dial |
| D— Input Box | |

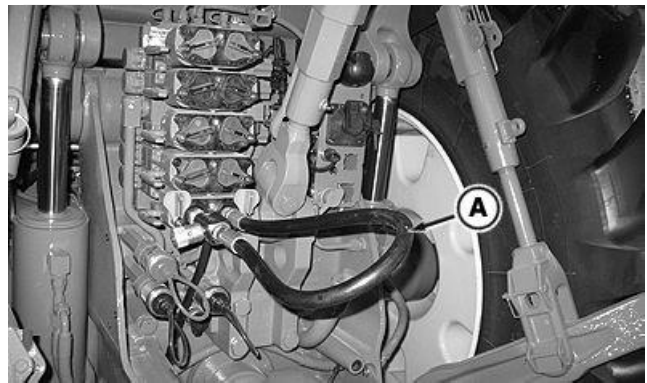

Install Jumper Hose Into SCV Coupler

RXA0127009 —UN—20JUL12



Menu → Tractor Settings Tab → SCV Icon

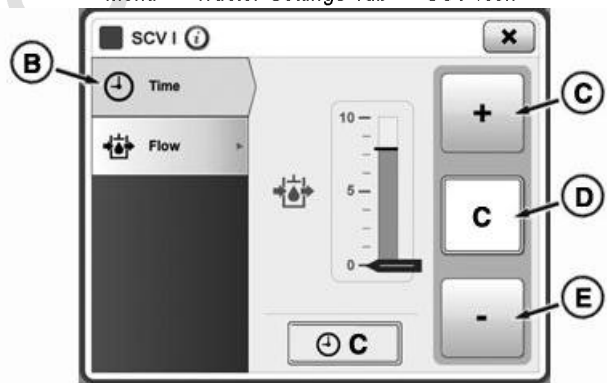

SCV Detent Time



CommandArm™

RXA0131231 —UN—09MAY13



Generation 4 Shortcut Bar

Continued on next page

RD47322,00000CE -19-06SEP13-1/3

RXA0131636 —UN—28MAR13

RXA0131886 —UN—09APR13

RXA0132429 —UN—10MAY13

Set Detent Flow

1. Select SCV I flow tab (A).

NOTE: Flow is displayed in increments of 0.04 beginning at 0.04 through 10 located in input box (C). Pushing (+) increases flow by 0.04, pushing (++) increases flow by 1.00, and by pushing (-) and (- -) decreases flow by same increments.

2. Set SCV I flow to 8.00 or above (C) by pressing buttons (B) to increase flow or buttons (D) to decrease flow setting. Adjustment dial (G) can be used to increase or decrease desired detent time setting.
3. Pull SCV I lever (E) to extend.
4. Set SCV II to C (Continuous) using steps 2 through 7 in Setting Time Flow.
5. Select SCV II button and pull SCV II lever (F) to flow oil.
6. Operate engine at 1400 rpm.

- | | |
|--------------------------|-------------------|
| A— SCV 1 Flow Tab | E— SCV I Lever |
| B— Increase Flow buttons | F— SCV II Lever |
| C— Flow Input Box | G— Adjusting Dial |
| D— Decrease Flow buttons | |

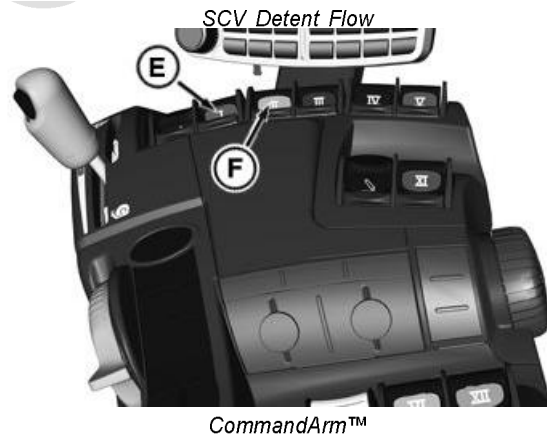
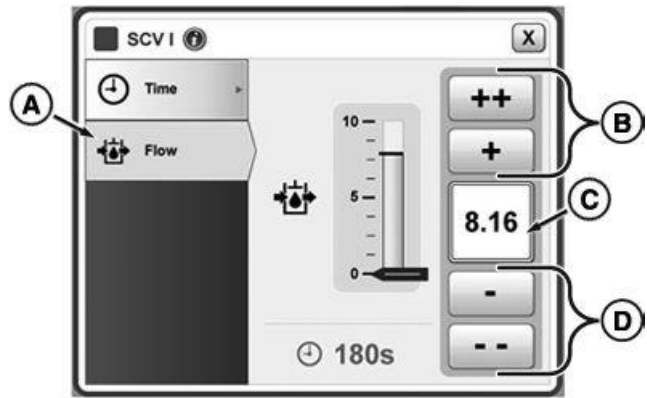

Generation 4 Shortcut Bar

Continued on next page

RD47322,00000CE -19-06SEP13-2/3

RXA0131683 —UN—28MAR13

RXA0131684 —UN—28MAR13

RXA0131233 —UN—09MAY13

RXA0126813 —UN—12JUN12

Monitoring Hydraulic Oil Temperature

1. Select **Menu**.
2. Select **Applications tab**.
3. Select **Machine Monitor icon**.
4. Select **Temperature tab**.
5. Monitor hydraulic temperature screen (A) until temperature reaches 38 °C (100 °F).
6. Return SCV I and SCV II lever to neutral position.
7. Disconnect jumper hose and return to normal operation..



Menu → Applications Tab → Machine Monitor Icon.

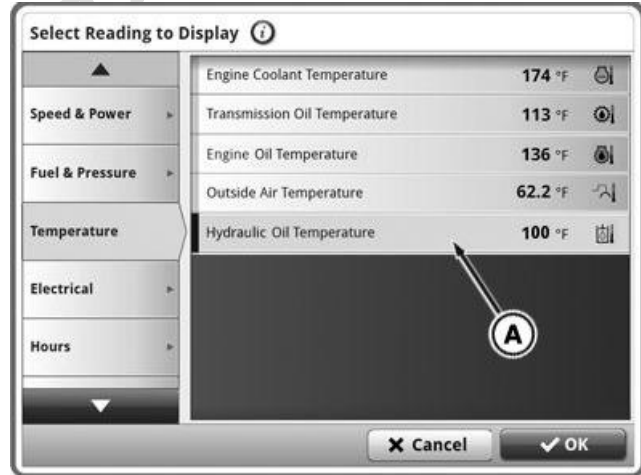

Temperature Display

RXA0131988 —UN—12APR13

RD47322.00000CE -19-06SEP13-3/3

P
R
O
O
F

Using FieldCruise™

Engine must be running for FieldCruise™ adjustment to operate.

FieldCruise™ utilizes a constant speed governor curve, providing instant response to varying loads.

Limiting engine speed in light load situations may improve fuel economy.

Engine speed can be adjusted from 1050 to 2100 rpm. Changes to rpm setting take place immediately.

NOTE: Selecting appropriate CommandCenter™ e23™ or IVT™ /AutoPowr™ setting is the preferred method of controlling engine rpm, but FieldCruise™ can be considered for certain applications such as PTO operation when baling.

Activate FieldCruise™

1. Select **Menu** .
2. Select **Tractor Settings** tab.
3. Select **Engine** Icon.
4. When engine page appears, select **FieldCruise™ Speed 1 (A) or 2 (B) On/Off toggle button** .

Adjust Engine RPM

1. Select **FieldCruise™ RPM button (C)**.
2. At RPM input box (E) select desired RPM, by pressing increase RPM buttons (F) or decrease RPM buttons (G). “++” and “--” buttons increase or decrease values at higher rate that “+” and “-” buttons.

- | | |
|---|-------------------------|
| A—FieldCruise™ Speed 1 On/Off Toggle button | E—RPM Setting input box |
| B—FieldCruise™ Speed 2 On/Off Toggle button | F—RPM Increase buttons |
| C—RPM Speed 1 Input module | G—RPM Decrease buttons |
| D—RPM Speed 2 Input module | |

FieldCruise is a trademark of Deere & Company
 CommandCenter is a trademark of Deere & Company
 e23 is a trademark of Deere & Company
 IVT is a trademark of Deere & Company
 AutoPowr is a trademark of Deere & Company

RXA0127004 —UN—20JUL12

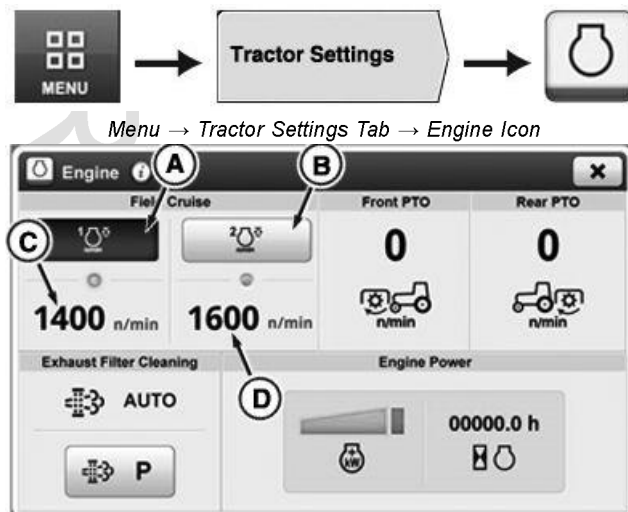

Engine Page

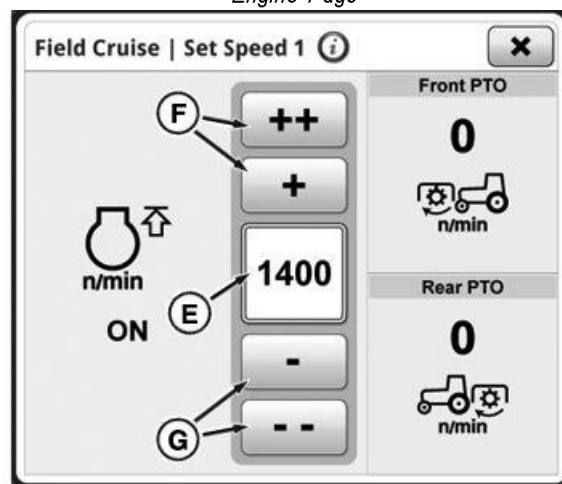

RPM Set Speed Display

RXA0132500 —UN—15MAY13

RXA0131032 —UN—18FEB13

TO84419,00000CF -19-06SEP13-1/1

Intelligent Power Management (If Equipped)

Intelligent Power Management (IPM) is available as factory or field installed option. IPM provides controlled power boost of up to 26kW (35hp) or tractor when:

- Accelerating at transport speeds, power boost occurs in steps through range of 23-28 km/h (14.3-17.4 mph).
- Decelerating at transport speeds, power boost ramps down in equal steps in range of 23-18 km/h (14.3-11.2 mph).
- PTO is under load and consuming moderate power and tractor is moving at 0.5 km/h (0.3 mph) or more.
- With tractor moving and rear PTO under load or in transport above 23 km/h (14.3 mph), power increase indicator will appear on display and IPM level is displayed on CommandCenter™

Power increase is not provided under draft applications or non-loaded rear PTO applications. Power increase is only provided when required.

1. Select **Menu** .
2. Select **Tractor Settings tab**.
3. Select **Engine Icon**.
4. Select IPM module (A) to activate IPM.
5. IPM On/Off toggle appears.
6. Toggle ON IPM (C).
7. IPM engaged icon (D) appears.

When IPM is engaged, IPM level is identified by solid portion displayed. Segments to right of solid portion indicate additional engine power above rated.

A—Intelligent Power Management Module
B—Power Management Off Toggle

C—Power Management On Toggle
D—Power Management Engaged Icon

RXA0127004 —UN—20JUL12



Menu → Tractor Settings Tab → Engine Icon



Intelligent Power Management

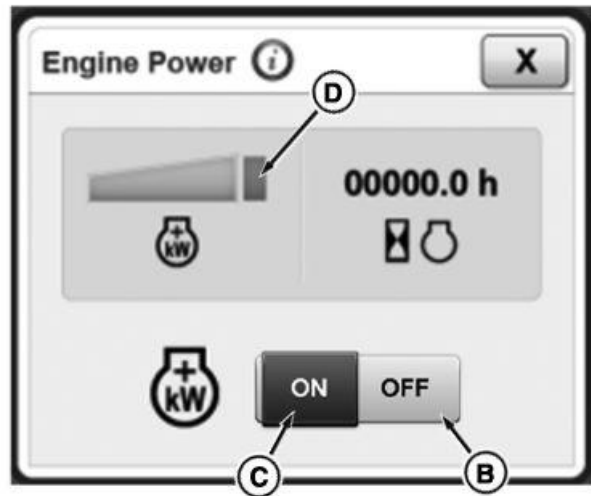

IPM On Display

CommandCenter is a trademark of Deere & Company

TO84419,00000D0 -19-08AUG13-1/1

RXA0130122 —UN—02JAN13

RXA0129722 —UN—30NOV12

Triple Link Suspension Plus (TLS™ Plus) (If Equipped)

Triple Link Suspension Plus (TLS™ Plus) provides suspension for tractor front end using hydro-pneumatic self leveling system. TLS™ Plus can operate simultaneously, yet independently from Load/Depth Control and Hitch Dampening.

Operating Characteristics

⚠ CAUTION: Avoid possible injury. Always make sure transmission is in Park position when working in area of TLS™ Plus MFWD.

IMPORTANT: Check for adequate clearance with TLS™ Plus system when attaching front mounted implement.

When tractor is stopped or moving faster than 0.5 km/h (0.3 mph), TLS™ Plus automatically levels when placing transmission in gear or from park position.

TLS™ Plus self levels with implement attached and hitch is raised or lowered.

Cold Weather Operation

Use normal cold weather procedures. TLS™ Plus system may require extra time to function correctly. TLS™ Plus system may not operate if system has not recentered during first 80 seconds of operation. Several restarts may be required. If it still doesn't start, contact your John Deere™ dealer.

Troubleshooting

If fault occurs in leveling control, Service Alert indicator (A) comes on, and a DTC message appears on

*TLS is a trademark of Deere & Company
John Deere is a trademark of Deere & Company
CommandCenter is a trademark of Deere & Company*



TLS™ Plus

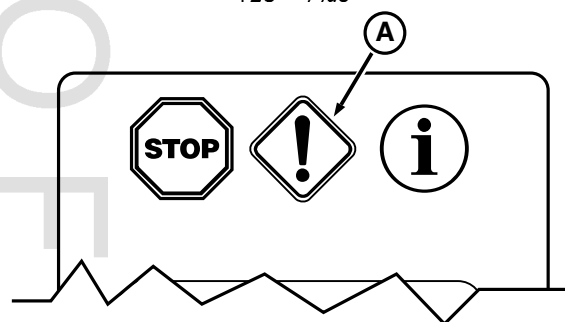

A—Service Alert Indicator

CommandCenter™ display. To clear fault, stop and restart engine; if fault reoccurs, contact your John Deere™ dealer.

RXA0110327 —UN—13SEP10

RXA0068147 —UN—22JUN03

TO84419,00000B6 -19-15AUG13-1/1

Operate TLS™ Plus and Cab Suspension (If Equipped)

IMPORTANT: Cab suspension should never hit end stops. If this occurs, select a stiffer setting.

1. Select **Menu** .
2. Select **Tractor Settings** tab.
3. Select **Suspension Icon**.
4. Select desired front axle and cab suspension setting.

TLS™ Plus Front Axle Suspension can be set for two different firmness levels and a manual positioning option: “AUTO” (A), “MAX” (B), and “Manual” (C).

Suspended front axle engages whenever tractor speed exceeds 0.5 km/h (0.3 mph). There is a delay in control after tractor begins moving. Suspension is active anytime transmission is not in PARK.

If “Auto” (A) is selected, suspension reacts in response to surrounding conditions and events. Provides best possible comfort by looking at inputs such as travel speed, surface characteristics, implement weight, implement usage and braking activity.

If “MAX” (B) is selected, suspension is set to maximum firmness (e.g. for operation with a front loader). When travel speed exceeds 30 km/h (18 mph), “MAX” setting is deactivated. When travel speed drops below 20 km/h (12 mph) again, “MAX” setting is reactivated.

When “Manual” (C) is selected, operator is able to adjust chassis height by pressing Raise button (G) or Lower button (H). Manual setting is overridden when travel speed exceeds 5 km/h (3 mph). When overridden, system returns to “Auto”.

Cab Suspension can be set for three different firmness levels: “Auto Soft” (D), “Auto Medium” (E), and “MAX” (F).

“Auto Soft” (D) enables cab suspension to operate from 0%—100% stiffness. Provides best suspension for transport situations. Cab suspension moves most with this setting. If less cab movement is desired, select a stiffer setting.

“Auto Medium” (E) enables cab suspension to operate from 50%—100% stiffness. Provides best suspension for field operation.

“MAX” (F) enables cab suspension to always operate at 100% stiffness. Most suitable for loader operations or operations that require frequent shuttle shifting.

TLS is a trademark of Deere & Company

RXA0127014 —UN—20JUL12



Menu → Tractor Settings Tab → Suspension Icon

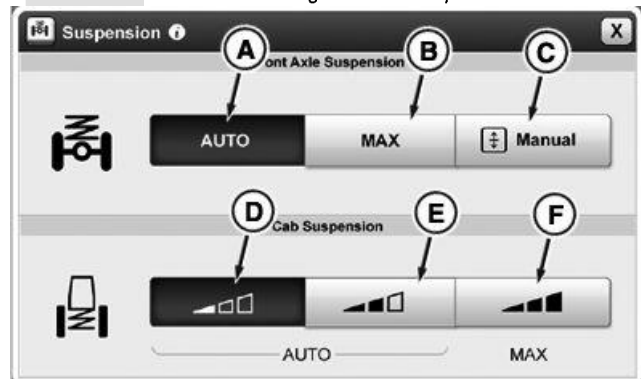

Suspension Page

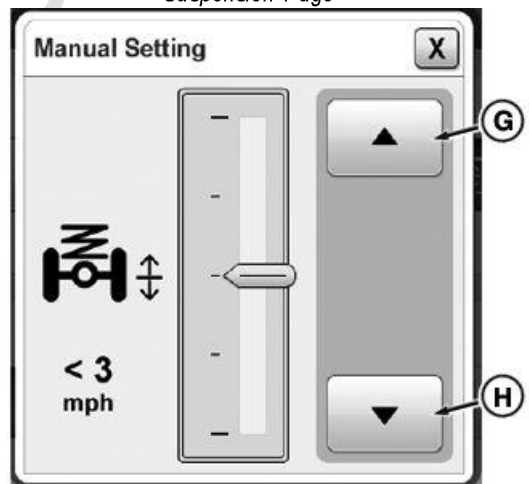

Manual Settings Page

- | | |
|---|---|
| A—Front Axle Suspension Auto Setting button | E—Cab Suspension Auto Medium Setting button |
| B—Front Axle Suspension MAX Setting button | F—Cab Suspension MAX Setting button |
| C—Manual Positioning Setting button | G—Raise button |
| D—Cab Suspension Auto Soft Setting button | H—Lower button |

RXA0131033 —UN—18FEB13

RXA0131034 —UN—18FEB13

T084419,00000D1 -19-04SEP13-1/1

Using Differential Lock

IMPORTANT: Engage differential lock before entering situation where wheel slippage may occur or when all wheels appear to be turning at same speed. If engaged after wheels begin to spin, damage to differential could result.

NOTE: On tractors with front and rear differential locks, front axle differential lock will engage when rear differential lock engages.

When one wheel begins to slip, differential lock can be engaged by selecting either of the two operating positions:

Auto Lock — Enter Auto mode by pressing Auto Lock switch (A) on armrest. When in auto mode, LED in Auto lock switch (A) illuminates. Differential lock indicator (C) illuminates when differential lock is engaged. Auto Lock:

- Disengages when wheel speed is more than 23 km/h (14 mph), one or both brake pedals are depressed, or turning at angle greater than 6 degrees.
- Engages when wheel speed falls below 19 km/h (12 mph), turning angle less than 6 degrees, and brakes are released.

NOTE: When Auto lock switch (A) is pressed, button is always lit until pressed again. Differential lock will remain in Auto mode until operator selects Manual Lock (B), Differential Lock switch (D) or press Auto Lock switch (A) again. Differential Lock indicator (C) turns on and off depending on the state of differential lock.

Manual Lock — Enter Manual mode by pressing either Manual Lock switch (B) on armrest or Differential Lock switch (D). When in Manual mode, LED in Manual Lock switch (B) and Differential lock indicator (C) will be illuminated. Press Manual Lock switch (B) a second time or depress one or both brake pedals to disengage Manual mode.

A—Auto Lock Switch
B—Manual Lock Switch

C—Differential Lock Indicator
D—Differential Lock Switch

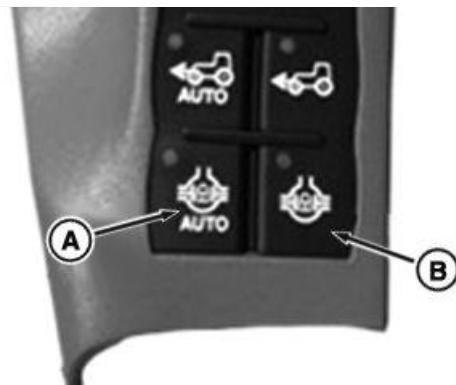

CommandARM™ Differential Lock Switch



Corner Post Display

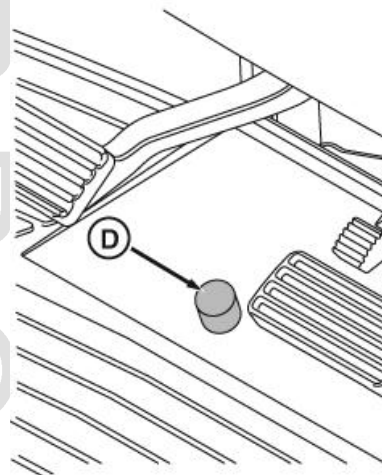

RXA0131622 —UN—01APR13

RXA0129258 —UN—31OCT12

RXA0131621 —UN—28MAR13

T084419,00000D2 -19-23JUL13-1/1

Mechanical Front-Wheel Drive (MFWD)

CAUTION: Avoid personal injury or death. Reduce speed when driving on icy, wet, or graveled surfaces.

Ballast tractor correctly to avoid skidding and loss of steering control. Engage front-wheel drive by using MFWD switch mode, rather than AUTO mode for four wheel braking.

IMPORTANT: Use AUTO MFWD or Brake Assist when transporting tractor.

MFWD can be engaged and disengaged in all gears (forward and reverse) during operation and under full load. Select one of three operating modes:

AUTO MFWD (A) — Enter Auto mode by pressing AUTO switch (A) on armrest. While in Auto mode, LED in AUTO switch (A) illuminates. MFWD indicator (C) illuminates when MFWD is engaged. Following is how MFWD operates in AUTO position:

- MFWD automatically *disengages* when either brake pedal is pressed, or at speeds above 23 km/h (14 mph).
- MFWD automatically *engages* when speed falls below 19 km/h (12 mph) or when BOTH brake pedals are depressed..

Manual MFWD (B) — Enter Manual mode by pressing Manual MFWD switch (B). While in Manual mode, LED in Manual MFWD switch (B) and MFWD indicator (C) illuminate until disengaged. To disengage Manual MFWD mode, press illuminated Manual MFWD switch (B). MFWD is engaged when transmission is in PARK.

Brake Assist — If neither Manual or Auto mode are selected, MFWD will be in Brake Assist mode. In Brake Assist mode, MFWD will be off unless both brake pedals are depressed at speeds above 5 km/h (3 mph).

A—AUTO Switch C—MFWD Indicator
B—Manual MFWD Switch

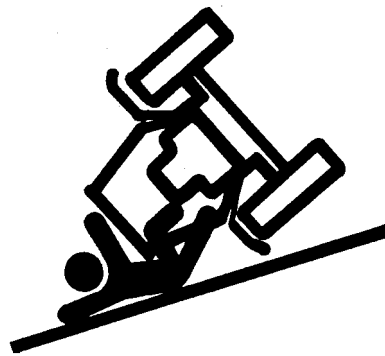

RW13089 —UN—07DEC88

RXA0130066 —UN—14DEC12

RXA0129259 —UN—31OCT12

TO84419,00000D3 -19-28AUG13-1/1

AutoTrac™ Assisted Steering System (If Equipped)

NOTE: Electro-hydraulic steering is required for AutoTrac™ to function. Refer to AutoTrac™ Operator's Manual for detailed instructions.

- AutoTrac™ system utilizes StarFire™ position receiver (A), and GreenStar™ display and mobile processor (B) to assist operator in steering tractor (see Installing GreenStar™ System Components in Operator Station section of this Operator's Manual).
- Operator must enter implement width minus overlap desired in GreenStar™ display, and drive first field pass in straight line, to enter starting and ending points of desired path.
- To activate AutoTrac™ initially, push Resume switch located on CommandARM™ after GreenStar™ display has been enabled. For each field pass after that, mark (C) on display should stay in middle of tractor hood, when AutoTrac™ is being used.
- AutoTrac™ is a straight-line guidance system. Operator must turn vehicle at end of each pass and to go around any field obstacles. Steering control is obtained by turning steering wheel.

A—Position Receiver
B—Mobile Processor

C—Mark

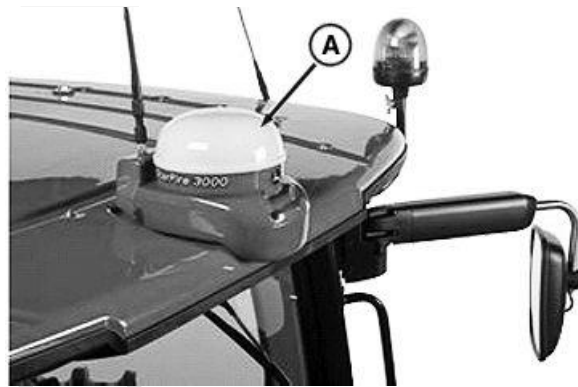

AutoTrac is a trademark of Deere & Company

TO84419,00000D4 -19-23JUL13-1/1

RXA0109998 —UN—20AUG10

RXA0110852 —UN—10SEP10

PROOF

Using Autoclutch (If Equipped)

Some transmissions are equipped with an AutoClutch feature. With AutoClutch when the operator presses the brake pedals, clutch is disengaged, pressing brake pedals further then applies the rear brakes (Front brakes as well - if equipped). Continued pressing of the pedals re-engages the clutch to allow the transmission to assist in slowing the tractor.

Adjusting AutoClutch Sensitivity

Press **Transmission Shortcut** button or follow **alternative path**:

1. Select **Menu**.
2. Select **Tractor Settings** tab.
3. Select **Transmission Icon**.
4. Select **Advanced Settings** icon.
5. Select **Settings** tab.
6. Select appropriate AutoClutch setting.
 - Low (A) is for heavy trailers (load).
 - Medium (B) is for medium trailers (load).
 - High (Factory Default) (C) is for light or no trailer (load).

NOTE: To keep AutoClutch from disengaging before trailer brakes are applied, AutoClutch Sensitivity options allow operator to adjust AutoClutch settings to load requirements. Larger trailers take lower AutoClutch Sensitivity settings. **AutoClutch Sensitivity factory default setting is set to High, which will support most operations.**

- | | |
|--|--------------------------------------|
| A—Low AutoClutch Sensitivity Toggle | C—High AutoClutch Sensitivity Toggle |
| B—Medium AutoClutch Sensitivity Toggle | |

RXA0133712 —UN—16JUL13



Transmission Shortcut Button on Navigation Bar

RXA0128094 —UN—14SEP12



Menu → Tractor Settings Tab → Transmission Icon

RXA0130326 —UN—11JAN13

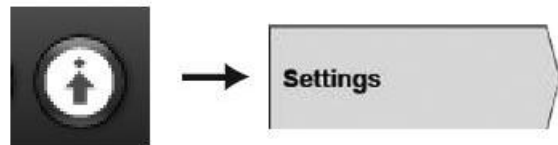

Advanced Settings Icon → Settings Tab

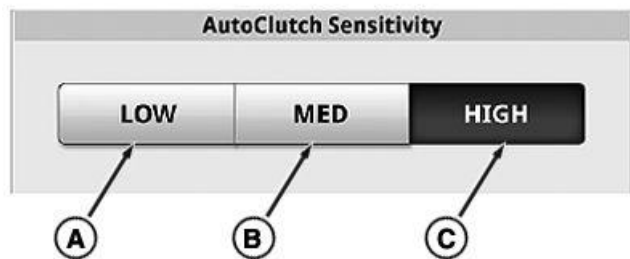

Autoclutch Sensitivity and Acceleration Aggressiveness Module

RXA0127888 —UN—07FEB13

RD47322,0000260 -19-13AUG13-1/1

Using the Brakes

⚠ CAUTION: Avoid possible injury from losing control of tractor:

- Lock brake pedals together with pedal lock tab (B) when operating on roads.
- Reduce speed if towed load weighs more than tractor or when transporting loads under adverse conditions. Avoid hard braking applications. (See Transporting Towed Equipment, in Transport Section of this Operator's Manual.)
- Tractor wheels may lock and skid on slippery downhill slopes. For IVT™/AutoPowr™ tractors, see Downhill Operation and Slippery Conditions, in the IVT™/AutoPowr™ Transmission section.

IMPORTANT: MFWD engages if MFWD Brake Assist mode is selected and both brake pedals are depressed at speeds above 5 km/h (3 mph) (see Mechanical Front-Wheel Drive (MFWD) in this section for more information).

IMPORTANT: Avoid unnecessary wear on brakes and increased fuel consumption. **DO NOT** rest feet on brake pedals during tractor operation.

Test brakes with engine stopped to be sure manual brake system is functioning (see 250 Hour Service section of this Operator's Manual).

Use individual brake pedals to assist in making sharp turns when working in field.

AutoPowr is a trademark of Deere & Company

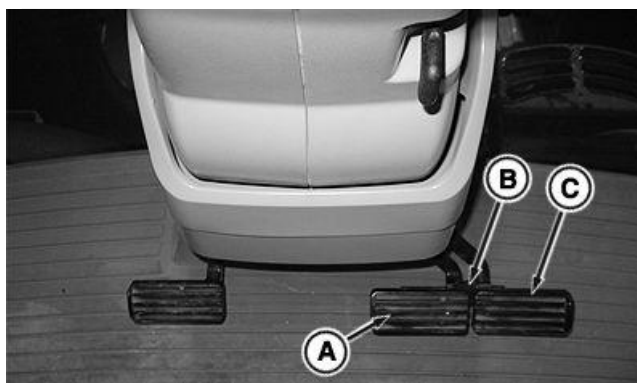

Lock Individual Brakes Together While Transporting

A—Left Brake Pedal
B—Pedal Lock Tab

C—Right Brake Pedal

Depress both brake pedals to stop tractor while disengaging clutch pedal.

Individual brake pedals can assist with slow speed off road turning, such as when hooking up implements.

For IVT™/AutoPowr™ Tractors Only

When operating at slow idle, individual brake pedals stop tractor without use of clutch pedal. To assist slow speed turning, depress either brake pedal while slowly increasing engine speed until desired turn is achieved. Returning engine speed to slow idle while continuing to depress one brake pedal will slow tractor to stop.

RXA0129148 —UN—30OCT12

TO84419,00000D5 -19-23JUL13-1/1

Hydraulic Trailer Brakes (If Equipped)

⚠ CAUTION: Avoid possible injury from losing control of tractor equipped with IVT™/AutoPowr™ transmission operating on downhill slopes. Tractor wheels may lock and skid on slippery downhill slopes (see Downhill Operation in Slippery Conditions in Operating IVT™/AutoPowr™ Transmission section of this Operator's Manual).

Remove dust cover from hydraulic trailer brake coupler (A). Connect pressure hose to brake coupler, making sure hose end and coupler are clean.

IMPORTANT: To reduce brake wear, make sure pressure hose is connected, select same gear for both downhill and uphill driving, and check hydraulic trailer brake regularly for correct functionality.

Depress brake pedals to operate hydraulic trailer brake. Braking effect depends on pressure applied to brake pedals.

Bring tractor-trailer to complete stop, shift transmission to PARK before dismounting tractor and disconnecting hydraulic lines from couplers. Seal connections with dust covers whenever hoses are disconnected.

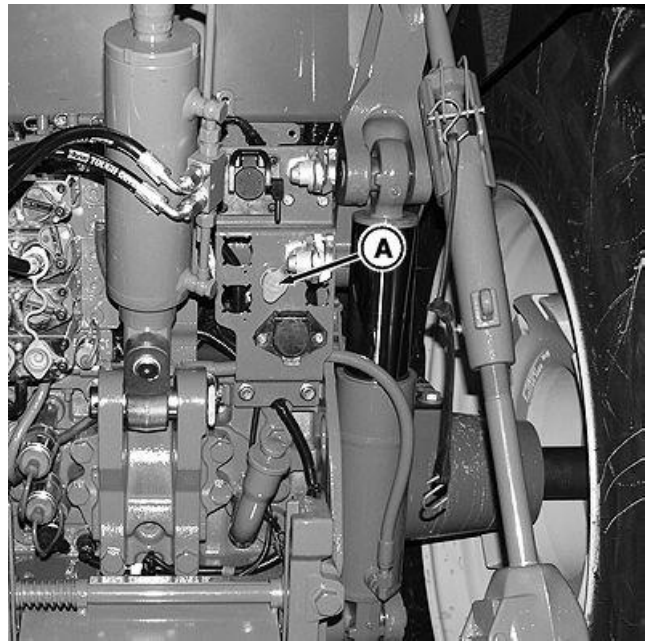

RXA0112902 —UN—14JAN11

A— Hydraulic Brake Coupler

TO84419,00000D6 -19-23JUL13-1/1

P
R
O
O
F

Trailer Air Brakes (If Equipped)

CAUTION: Avoid possible injury from losing control of tractor equipped with IVT™/AutoPowr™ transmission operating on downhill slopes. Tractor wheels may lock and skid on slippery downhill slopes (see Downhill Operation in Slippery Conditions in IVT™/AutoPowr™ Transmission section of this Operator's Manual).

Dual-line braking system employs yellow (A) and red (B) couplers.

Clean connections before attaching air hoses. Connect trailer line that goes to yellow air brake coupler (control line) first. Lift dust cover from trailer air brake coupler and connect trailer hose coupling. Seal connections with dust covers whenever hoses are disconnected.

Start engine and allow air system to reach working pressure. While air pressure builds, Diagnostic Trouble Code and an accompanying message comes on CommandCenter™ display. When operating pressure is reached, indicator light and warning display shut off automatically.

IMPORTANT: To reduce brake wear, make sure pressure hoses are connected, select same gear for both downhill and uphill driving, and check air brake on trailer regularly for correct functioning.

IMPORTANT: With trailer lines connected, do not drive tractor until operating pressure

*IVT is a trademark of Deere & Company
AutoPowr is a trademark of Deere & Company
CommandCenter is a trademark of Deere & Company*

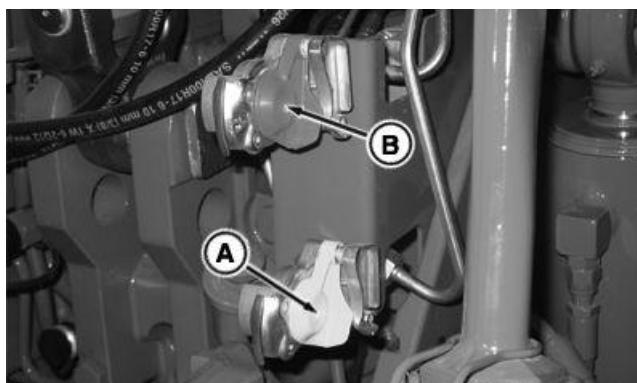

Brake Couplers

A—Yellow (Dual-line)

B—Red (Dual-line)

is reached and service alert indicator and warning display are off.

Depress brake pedals to stop tractor-trailer while disengaging clutch pedal. Depressing clutch pedal to stop tractor equipped with IVT™/AutoPowr™ transmission is not necessary (see Stopping and Parking Tractor in Operating IVT™/AutoPowr™ Transmission section).

Trailer air brakes are equipped with an automatic bleed valve which can be checked manually (see Bleed Trailer Air Brake in As Required section of this Operator's Manual).

RXA0128558 —UN—04OCT12

TO84419,00000D7 -19-24JUL13-1/1

Come Home Mode

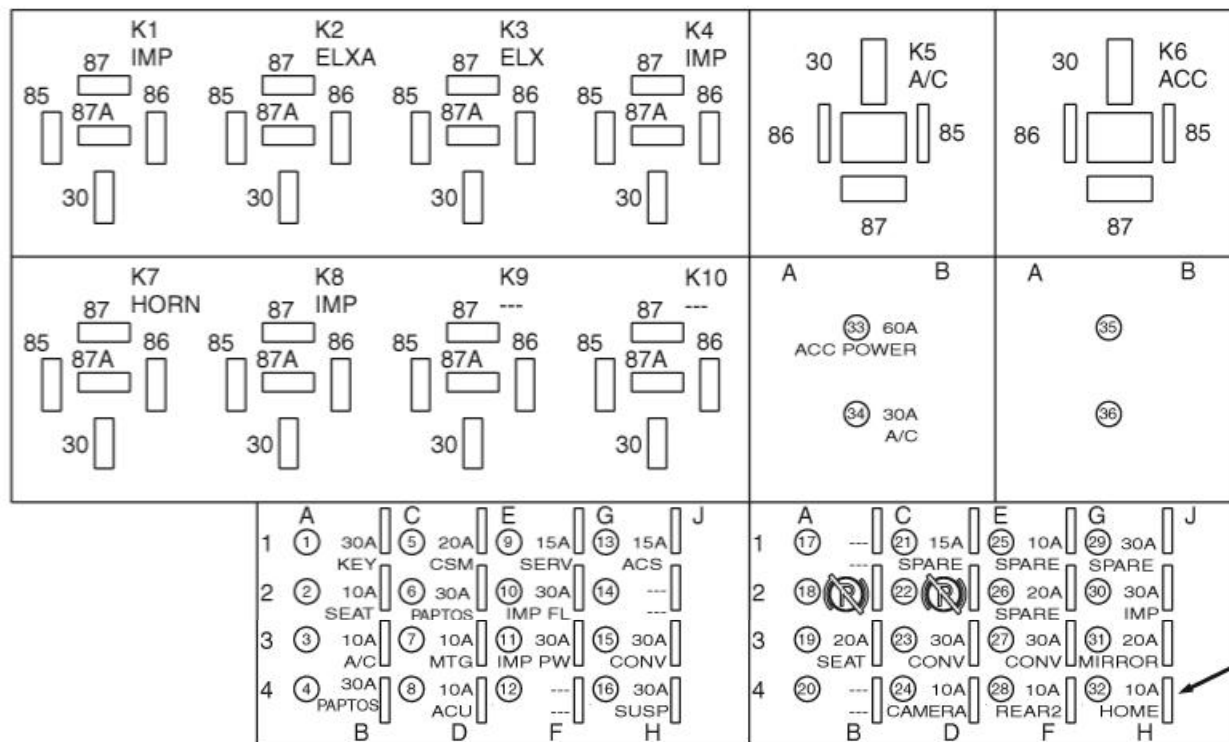

A—#32 Fuse

Come home mode is used when tractor becomes inoperable due to failures and must be moved.

For e23™ transmissions in come home mode, tractor engine speed is limited to 1500 rpm and Efficiency Manager™ is disabled.

For IVT/AutoPowr transmission in come home mode, maximum tractor speed is limited to 5 km/h (3.1 mph).

NOTE: Removing #32 fuse (A) diverts hydraulic oil through backup pump which supplies hydraulic oil to brakes and steering. Tractor can safely be moved short distances at lower speeds.

When tractor is placed in gear, backup pump will start. As long as tractor is in neutral any movement

of brake pedals or steering wheel will engage backup pump to supply hydraulic oil as needed.

When driving tractor in Come Home Mode, do not exceed tractor limited capability.

"Transmission come home active" will appear on CommandCenter™ display when come home mode is active.

1. Remove fuse #32 (A) and retain.
2. Start engine.
3. Step on brake pedal momentarily.
4. Depress clutch pedal.
5. Select Forward or Reverse direction.
6. Release clutch pedal to put tractor in motion.

CommandCenter is a trademark of Deere & Company

RW29387,00005E8 -19-24JUL13-1/1

RXA0129610—UN—25JAN13

Transmission Description and Controls

CommandQuad™ transmission has a hydraulically shifted range box which provides 20 forward and 20 reverse speeds (40 km/h ECO or 50 km/h ECO versions). Left hand reverser (H) provides fully modulated shift capability between forward and reverse. When shifting directions with left hand reverser (H) and changing ranges, direction must be established before ranges shift. Operator does not have to depress or release clutch pedal when shifting. When performing range shift, lights next to selected range button on CommandARM™ blink until shift is complete. In Auto Mode, engine speed, range, and gear are commanded automatically to achieve set speed and to manage heavy and light loads.

NOTE: During a range shift the clutch will be modulated.

Range Lock Mode: Range buttons (A, B, C) provide three shiftable ranges. Use Range Lock buttons when operating in conditions where range change is not needed or when operating with significant draft load. Changing ranges with significant draft load would result in interruption of ground speed.

Multi-Range Mode: Multi-Range button (D) provides automatic range shifting when in Auto Mode. There are four power shiftable gears in any range. Selected ranges can be shifted manually using shift lever (E) or automatically when shift lever (E) is set in AUTO position.

- | | |
|-----------------------|----------------------------|
| A— A Range Button | E— Shift Lever |
| B— B Range Button | F— Set Speed Adjuster Dial |
| C— C Range Button | G— Hand Throttle |
| D— Multi-Range Button | H— Left Hand Reverser |

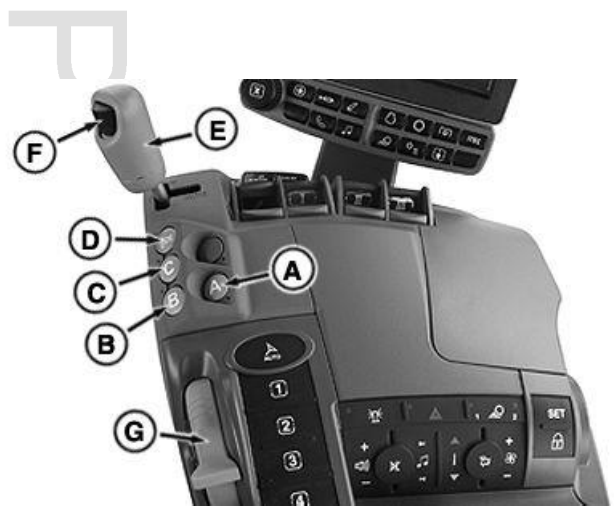

Left Hand Reverser

RXA0127844 —UN—22AUG13

RXA0130485 —UN—15JAN13

RD47322,0000244 -19-05SEP13-1/1

P
R
O
O
F

Operating Transmission

CAUTION: Avoid personal injury or damage to tractor. If engine starts with left-hand reverser lever in forward or reverse positions, there is a malfunction in starting circuit. Repairs should be made immediately by your John Deere™ dealer.

IMPORTANT: Prevent Transmission or Clutch Damage

- Never depress clutch pedal while tractor is rolling downhill or coasting, as serious transmission damage may result.
- Never attempt to start tractor by towing or pushing.
- Stop tractor completely before shifting to PARK position.
- Avoid excessive ballast.
- Clutch pedal must be fully depressed to disengage clutch. Never rest foot on clutch pedal while tractor is moving.

NOTE: The seat assembly contains an operator presence safety device to prevent initiation of movement of tractor without operator sitting in seat.

Shifting Transmission

Auto Mode—Place left-hand reverser (H) into desired directional slot. Slide transmission shift lever (E) right into AUTO slot. When in Auto Mode, operator may select Range Lock Mode by pressing single range button (A, B, or C). While transmission is in Range Lock Mode, it is only able to shift through gears in selected range. To put transmission in Multi-Range Mode, select Multi-Range button (D); transmission shifts through gears and ranges that are selected in Transmission page. When in Full AUTO mode, the minimum engine speed is 1200 rpm. Transmission shifts gears based on throttle position and set speed while in Auto Mode. When throttle is pulled back, transmission shifts to selected Start Gear (see Multi-Range Button Settings in this section). Wheel speed can be set by scrolling set speed adjuster (F) up or down. iTEC™ function can control set speeds while in Auto Mode.

Manual Mode—Place left-hand reverser (H) into desired directional slot. Slide shift lever (E) left. In Manual Mode, operator selects desired range by pressing range button (A, B, or C). In each range there are four gears. Use shift lever (E) to shift up (+) or down (-) through gears. While using Range Lock Mode, operator must select different ranges by pressing one of range buttons (A, B, or C). While using Multi-Range Mode (D) operator does not have to select different ranges, transmission shifts through gears and ranges when shift lever (E) is bumped forward or backward. iTEC™ function can control gears while in Manual Mode.

Additional Information

Following are when operator should use shift lever (E) to shift between ranges:

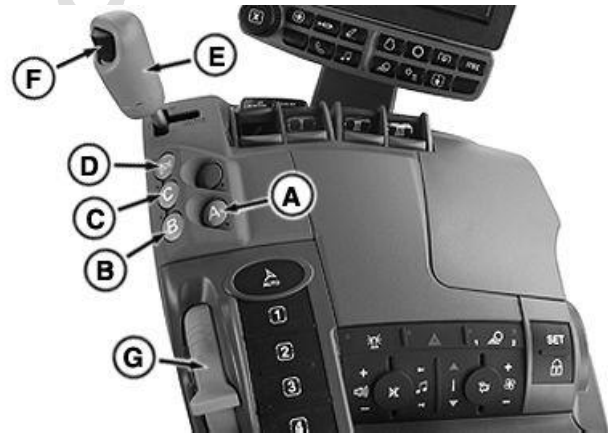

Left-Hand Reverser

- | | |
|----------------------|----------------------|
| A—A Range Button | E—Shift Lever |
| B—B Range Button | F—Set Speed Adjuster |
| C—C Range Button | G—Hand Throttle |
| D—Multi-Range Button | H—Left-Hand Reverser |

- When in highest gear in one range, single bumping shift lever (E) causes transmission to shift to appropriate gear in next range (D4 to E range).
- When in mid-gear in one range, double bumping shift lever (E) causes transmission to shift from one range directly to speed-matched gear in next range (D2 to E1).
- Pressing and holding shift lever (E) will cause transmission to shift up continuously based on engine speed, load, gears, and ranges if in Multi-Range Mode, or load and gears if in Range Lock Mode.

Corner post display shows transmission's current state (P, N, F, or R), selected gear (1-4), and range (A-E) (refer to Ground Speeds in Specifications section for range/gear settings).

NOTE: When engine shuts off, left hand reverser remains in its selected position but transmission shifts into neutral. To start engine, put left hand reverser in Park.

Continued on next page

RD47322,0000245 -19-22AUG13-1/2

RXA0127844 —UN—22AUG13

RXA0130485 —UN—15JAN13

Tractor cannot be put in gear unless operator is seated. Information indicator lights and corresponding message appears on CommandCenter™ display when Forward, Reverse, or Neutral positions are selected and operator is **not** in seat. To initiate motion, move lever from Park position to Forward or Reverse position with operator seated.

When clutch is disengaged, gear matching adjusts gear to allow for smooth clutch re-engagement. When engine speed of more than 1500 rpm is commanded, stall

threshold is 700 rpm. When stall threshold is reached, clutch may disengage. To engage transmission, move left hand reverser to PARK, reduce load, then shift back into desired operating direction.

Tractor protects against engine overspeed. If engine is running at full speed in current gear, transmission will automatically shift up to protect the engine from overspeeding. Transmission may shift up gears but not ranges if engine speed reaches 2800 rpm.

RD47322,0000245 -19-22AUG13-2/2

Adjusting Set Speeds

CAUTION: Avoid unexpected rapid acceleration. Check and adjust set speeds before putting tractor in motion.

1. Turn key switch to RUN position.
2. Move left-hand reverser out of Park position. Forward and reverse set speeds will scroll on corner post display pausing at each speed for 2 seconds.
3. Adjust each speed when it displays by rotating set speed adjuster on speed control lever forward to increase set speed value or rearward to decrease it.

NOTE: Set speed adjustments may affect corresponding set speed of opposite direction (see Adjusting Reverse/Forward Speed Ratio in this section).

On corner post display, set speed of selected speed band is displayed in orange and ground speed of tractor is displayed in white. Set speed can be adjusted while tractor is moving by rotating set speed adjuster dial (B). Increasing set speed value increases ground speed. Decreasing set speed value decreases ground speed. New set speed (A) is indicated on display.

4. Select set speed that is approximately 3.2 km/h (2 mph) higher than desired working speed in order to obtain maximum productivity in applications where precise forward speed is **not** critical, such as plowing. Tractor reaches higher set speed value during no load or light load condition.

A— Set Speed

B— Set Speed Adjuster Dial



Corner Post Display



Set Speed Adjuster Dial

Continued on next page

RD47322,0000246 -19-26AUG13-1/2

RXA0130015—UN—11DEC12

RXA0127845—UN—22AUG13

CommandQuad™ Ranges

- A—A Range
- B—B Range
- C—C Range
- D—BCDE Range
- E—CDE Range
- F—DE Range
- G—Set Speeds

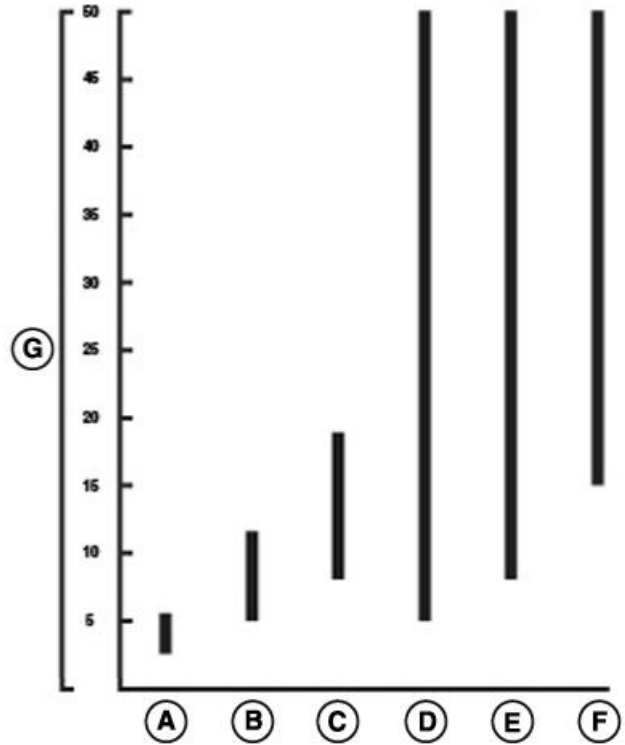

Set Speeds for Given Gears in km/h (Group 48 Tires)

Ranges	Min. Set Speed km/h (mph)	Max. Set Speed km/h (mph)
A Range	2.4 (1.5)	5.4 (3.4)
B Range	5.0 (3.1)	11.4 (7.0)
C Range	8.0 (5.0)	18.8 (11.7)
BCDE Range (As Selected)	5.0 (3.1)	40.0 or 50.0 (24.9 or 31.1) ^a
CDE Range (As Selected)	8.0 (5.0)	40.0 or 50.0 (24.9 or 31.1) ^a
DE Range (As Selected)	15.0 (9.3)	40.0 or 50.0 (24.9 or 31.1) ^a

Set Speeds For Given Gears (Group 48 Tires)

^aElectronically limited based on transmission specifications.

RXA0112769—UN—04JAN11

RD47322,0000246 -19-26AUG13-2/2

D
R
O
O
F

CommandCenter™ Transmission Main Page

RXA0133712 —UN—16JUL13

CommandQuad™ transmission offers two modes to get most fuel efficiency and load control from your tractor:

- **Full Auto**—Automatically adjusts minimum engine speed, allowing tractor to use most fuel efficient engine speed under light load. This mode automatically responds to loads created by use of hitch or SCVs (load anticipation). During PTO use, top engine speed is automatically limited to provide appropriate PTO speed.
- **Custom**—Operator can choose Auto Shift Engine Speed, ECO Engine Speed, or Load Anticipation reaction.

Press **Transmission Shortcut Button on Navigation Bar** or follow alternative path:

1. Select **Menu**.
2. Select **Tractor Settings** tab.
3. Select **Transmission** icon.

Forward maximum speed (E) or reverse maximum speed (F) displays maximum forward or reverse speed limits. To change maximum speed, select appropriate maximum speed module. Max Speed Forward or Max Speed Reverse page appears. Use increase (+) or decrease (-) buttons to set maximum speed. If operator changes maximum forward or reverse speed below current set speed, set speed decreases to maximum speed and vehicle speed decreases.



Transmission Shortcut Button on Navigation Bar

RXA0128094 —UN—14SEP12

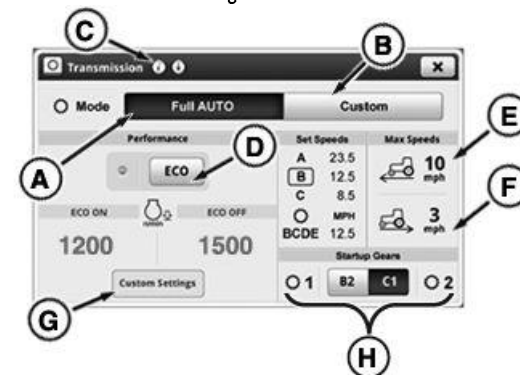

- A— Full Auto Mode
- B— Custom Mode
- C— Information and Settings Icon
- D— ECO ON/OFF Toggle

- E— Maximum Forward Speed
- F— Maximum Reverse Speed
- G— Custom Settings
- H— Startup Gear Toggle

RXA0130013 —UN—19MAR13

RD47322.0000247 -19-23AUG13-1/1

DRAFT

CommandQuad™ Custom Settings

NOTE: Settings discussed on this page are only applicable when CommandQuad™ transmission is in Custom Mode.

Press **Transmission Shortcut Button** on Navigation Bar.

1. Press **Custom Mode toggle**.

Under light loads, fuel can be saved by shifting up and throttling back. Auto mode does this automatically. While shifting in custom mode, however, system will not reduce engine speed below ECO Engine Speed (A, B) set by operator.

Auto Shift Engine Speed Droop (E, F) sets permissible drop in engine speed (under full load) before Custom Mode automatically downshifts. Lower percent means transmission downshifts earlier and higher percent means transmission downshifts later.

Load Anticipation (G, H and I) features allow CommandQuad™ transmission to predict loads when hitch, SCVs or PTO are in use. Load anticipation both shifts down transmission and increases engine speed to maintain wheel speed. This selection determines whether transmission increases engine rpm to get ECO Engine Speed above 1500 rpm when either hitch or SCVs are used. If hitch is lowered or raised, system increases engine rpm if engine speed is below 1500 rpm. If SCVs are set to extend or retract above 25% flow rate, engine increases rpm automatically. PTO load anticipation setting determines whether the engine speed should be raised to maximum engine speed determine by throttle and field cruise limit. If engine cannot keep minimum engine speed above 1500 rpm, transmission downshifts. SCV set to continuous flow also causes engine to increase rpm. Load Anticipation is enabled in "Full Auto" mode selected on Transmission page by default. In "Custom" mode, load anticipation for hitch is enabled when hitch toggle (G) is turned to ON. In "Custom" mode, load anticipation for SCVs is enabled when SCV toggle (F) is turned to ON. In "Custom" mode, load anticipation for PTO is enabled when PTO toggle (I) is turned to ON.

Set Auto Shift Engine Speed Droop PTO ON

NOTE: Auto Shift Engine Speed Droop PTO ON can be set from 6% —26 %

- From Transmission page, select Custom Settings button (D).
- Select Auto Shift Engine Speed Droop PTO ON module (E). Value adjustment page appears.
- Adjust percentage to desired value by using increase (+) and decrease (-) buttons.

Set Auto Shift Engine Speed Droop PTO OFF

NOTE: Auto Shift Engine Speed Droop PTO OFF can be set from 20% — 26 %.



Transmission Shortcut Button on Navigation Bar

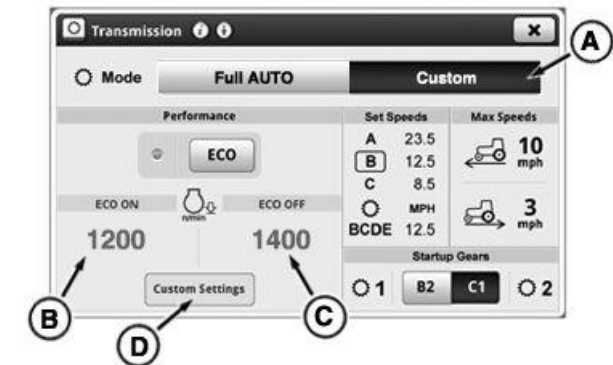

Transmission Home Page

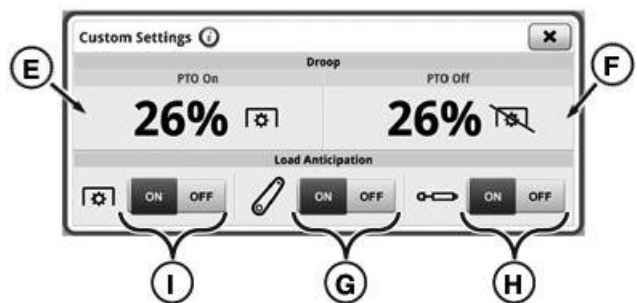

Transmission Custom Settings Page

- A— Custom Mode Toggle
- B— ECO Engine Speed ON
- C— ECO Engine Speed OFF
- D— Custom Settings button
- E— Auto Shift Engine Speed Droop PTO ON
- F— Auto Shift Engine Speed Droop PTO OFF
- G— Load Anticipation (Hitch)
- H— Load Anticipation (SCV)
- I— Load Anticipation (PTO)

- From Transmission page, select Custom Settings button (D).
- Select Auto Shift Engine Speed Droop PTO OFF module (F). Value adjustment page appears.
- Adjust percentage value to desired value by using increase (+) and decrease (-) buttons.

Set ECO ON Engine Speed

- From Transmission page, select ECO ON Engine Speed module (B). Value adjustment page appears.
- Adjust percentage to desired value by using increase (+) and decrease (-) buttons.

Set ECO OFF Engine Speed

- From Transmissions page, select ECO OFF Engine Speed module (C). Value adjustment page appears.
- Adjust percentage to desired value by using increase (+) and decrease (-) buttons.

Turn Load Anticipation ON

- From Transmission page, select Custom Settings button (D).
- Use Hitch Load Anticipation toggle (G), SCV Load Anticipation toggle (H) or PTO Load Anticipation toggle (I) to turn hitch, SCV or PTO load anticipation ON or OFF.

RD47322,0000248 -19-19AUG13-2/2

PROOF
PROOF
PROOF

RXA0133712 —UN—16JUL13

Advanced Settings Page

Press Transmission Shortcut Button on Navigation Bar.

1. Press **Advanced Settings Icon**.
2. Press **Settings Tab**.

- **A— Softshift Toggle Bar:** Use to change Softshift to AUTO, ON, or OFF.
- **B— Multi-Range Toggle Bar:** Use to change Multi Range button range to DE, CDE, or BCDE.
- **C— Start Gear button:** Select to access list of two different start gear options for selection.
- **D—Reverse/Forward Ratio button** Select to access list of reverse/forward ratio options.
- **E— Back Up Alarm ON/OFF Toggle:** If Equipped.

Multi-range Button Settings

Multi-range button can be set for applicable ranges (B) and start gear (C).

Ranges available for this button are DE, CDE, or BCDE. When Multi-Range button is selected, transmission is able to shift through these ranges when in both Manual Mode and AUTO Mode.

Start gears available for Multi-Range button vary from B1 to D4. In AUTO Mode, start gear is also used as low idle gear. In any Range Lock Mode, start gear is Gear 3.

Adjusting Reverse/Forward Speed Ratio

During shuttle shift, reverse gear can be selected to match forward gear.

Reverse/Forward ratio can be set to operate independent of each other, same as, between 1 to 3 gears slower, or 1 to 3 gears faster than selected forward gear.

In Manual Mode, transmission uses this setting to choose new gear in same range in opposite direction. In AUTO Mode, transmission uses this setting to adjust set speed in opposite direction.

NOTE: If +3 is selected and gear is currently C4 in forward, C4 is range/gear in reverse.

Independent setting allows tractor to remember last forward and reverse gear setting. Once gear is manually changed in reverse direction, gear automatically returns to last gear when changing directions. If gear is not manually changed when in reverse direction, then forward gear and reverse gear remains same when changing directions. In AUTO Mode, reverse and forward set speeds function independent of each other.

Enable/Disable Softshift

Softshift provides smoother shifting between gears by providing short intermediate engine rpm adjustments between each gear shift.

- During upshift, engine rpm momentarily decreases at beginning of shift and then returns to current throttle setting.
- During downshift, engine rpm momentarily increases at beginning of shift and then returns to current throttle setting.



Transmission Shortcut Button on Navigation Bar

RXA0130326 —UN—11JAN13

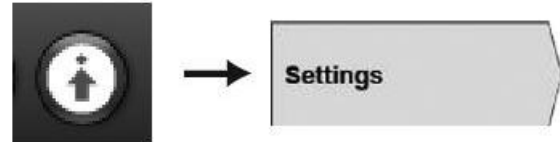

Advanced Settings Icon → Settings Tab

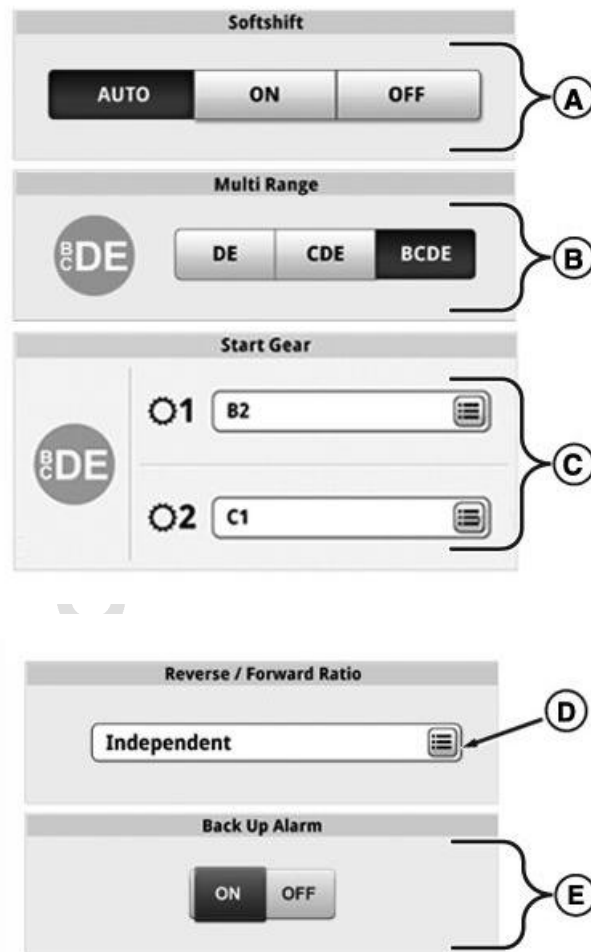

Transmission Settings Page 2

Continued on next page

RD47322,0000249 -19-22AUG13-1/2

RXA0130052 —UN—22AUG13

RXA0130847 —UN—19MAR13

Tractor Speed Displays on Corner Post Display and CommandCenter™

Set speed (A) is the maximum ground speed of selected range.

Ground Speed

Ground speed (B) value on tractors equipped with radar will always show a lower value than set speed selected if there is measurable wheel slip.

A— Set Speed

B— Ground Speed



RXA0130017—UN—11DEC12

RD47322,000024A -19-15JUL13-1/1

Downhill Operation in Slippery Conditions

CAUTION: Avoid possible injury from losing control of tractor while operating on a downhill slope. Tractor wheels may lock and skid on slippery downhill slopes. Observe the following precautions:

- Slide shift lever (A) to the left to select Manual Mode.
- Select an appropriate gear and range to reduce skidding.
- Turn MFWD on.

A— Shift Lever



RXA0125635—UN—23AUG13

RD47322,000024B -19-19AUG13-1/1

Operating e23™ Transmission with Right-Hand Reverser

⚠ CAUTION: Avoid personal injury or damage to tractor. If engine starts with shift lever in gear, there is malfunction of starting circuit. Repair should be made immediately by your John Deere™ Dealer.

IMPORTANT: Prevent transmission or clutch damage:

- Never depress clutch pedal while tractor is rolling downhill or coasting as transmission may over-speed and cause serious damage to the transmission.
- Never attempt to start tractor by towing or pushing.
- Operator can always move shift lever to PARK Position; however, park brake will not engage until ground speed is below 1.75 km/h (1.0 mph).
- Avoid excessive ballast.
- Avoid continuous operation under full throttle and full load conditions below 1800 rpm.

Shift transmission using lever (A) on CommandARM™.

Transmission can be shifted, without use of clutch pedal, into forward or reverse.

Clutch pedal allows operator maximum manual control of modulation for ease of connecting implements, operating in confined areas, or slow movement of tractor during precise maneuvers. Depress clutch pedal to preselect forward or reverse command gear from park.

When shift lever is moved from PARK to NEUTRAL position, park brake releases and corner post display (B) shows pre-selected forward or reverse gear and letter "N" for NEUTRAL. When lever is in forward or reverse, display shows "F" or an "R" along with commanded gear.

Engine only starts with shift lever (A) in PARK or NEUTRAL.

Shifts are made one at a time by "bumping" the shift lever. Multiple "bumps" or pushing and holding lever forward or pulling and holding lever rearward may result in skip shifts.

NOTE: The seat assembly contains an operator presence safety device to prevent initiation of movement of tractor without operator sitting in the seat.

NOTE: When the tractor is loaded to below low idle speed, the transmission may default to NEUTRAL for powertrain protection. The park brake engages once the wheel speed drops below 1.75 km/h (1.0 mph).

John Deere is a trademark of Deere & Company



Transmission Shift Lever with RH Reverser

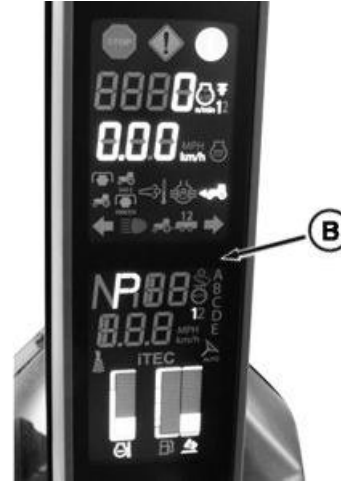

Corner Post Display

A— Transmission Shift Lever B— Corner Post Display

To re-engage transmission, move transmission lever to PARK, reduce load, and shift into desired operating gear.

A diagnostic trouble code is stored and displayed when this condition occurs.

RXA0130275—UN—19AUG13

RXA0135241—UN—21AUG13

RD47322.00000E1 -19-23AUG13-1/1

Shifting e23™ Transmission with Right-Hand Reverser

Shift Lever Positions

PARK — Rear slot (A) — The park brake is applied when lever is fully forward in the rear slot.

NEUTRAL — Right slot (B) — The park brake is released when lever is moved to the right slot.

Reverse — Center slot (C) — The tractor begins moving rearward when the lever enters this slot. Push lever forward for downshifts and pull rearward for upshifts.

Forward — Front slot (D) — The tractor begins moving forward when lever enters this slot. Push lever forward for upshifts and pull rearward for downshifts.

NOTE: Transmission is in **NEUTRAL** position whenever shift lever is not in **PARK**, forward, or reverse positions.

IMPORTANT: Operator can always move shift lever to **PARK** Position; however, park brake will not engage until ground speed is below 1.75 km/h (1.0 mph). Repeated engagement of the park brake, while the tractor is moving, may damage the park brake.

Command Gears

NOTE: Optimum engine speed is 1800 — 2200 rpm in full load conditions. Using higher gear and lower engine speed for light load operation saves fuel and reduces wear. Under full load conditions, use full throttle engine speed.

Each time transmission enters forward or reverse shift pattern, transmission starts in command gear, shown on corner post display.

Transmission starts out in F8 and R4 after engine is started. These are default command gears. Startup default command gears may be changed from F1 - F13 in forward and R1 - R6 in reverse (see Setting Start Gear in this section).

Command gear temporarily changes to the last gear used when shuttling between forward and reverse, or shifting from gear to neutral.

Forward Gear— Gears between F1 and F13 may be preselected by depressing clutch pedal, putting the shift lever in front (forward) slot, and bumping the shift lever up or down until the desired command gear is displayed.

Reverse Gear— Gears between R1 and R6 may be preselected by depressing clutch pedal, putting the shift lever in center (reverse) slot, and bumping the shift lever up or down until the desired command gear is displayed.

Transmission will start in the preselected forward or reverse gear when clutch pedal is released.

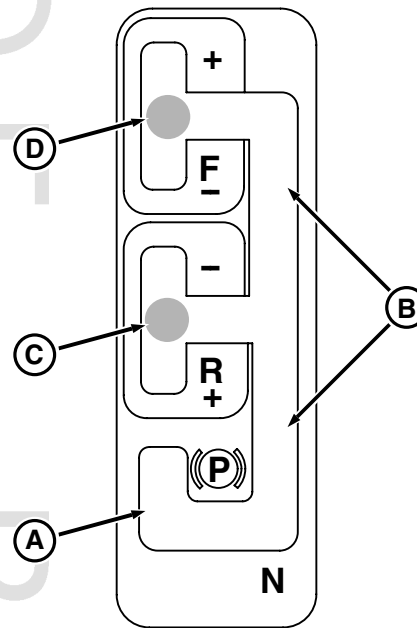
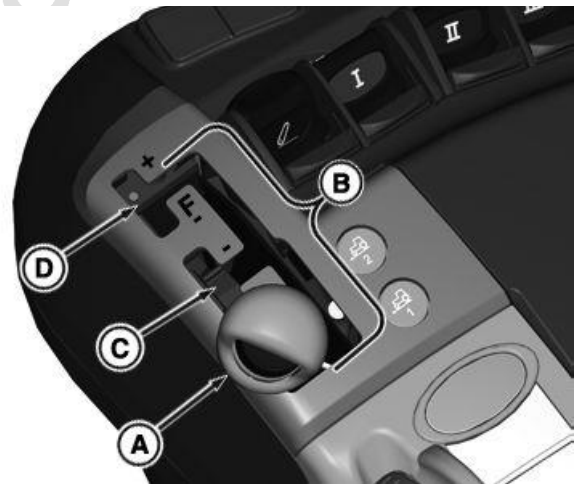

Lever Diagram

A— PARK
B— NEUTRAL
C— Reverse Gears
D— Forward Gears

Cold Weather Starting

When temperature is -10 °C (14°F) or lower, it may take one minute to the release park brake with operator in the seat and shift transmission lever in gear. Several shifts between **PARK** and **NEUTRAL** may be required to release park in extremely cold conditions.

When temperature is -10 °C (14°F) or above, it may take 3 seconds to release park brake with operator in the seat.

When shift lever is moved to NEUTRAL, corner post display shows “N” for three seconds. If park brake does not release, “N” changes back to “P”. Move shift lever back to PARK then back to NEUTRAL until “N” displays more than three seconds.

Delayed shifting, slow hydraulic operation, hard steering, and limited engine rpm may also be noticeable until operating temperature is obtained.

Shifting Without Using Clutch Pedal

Gear to Gear — Hold lever to shift up or down until desired gear is reached. Transmission shifts one gear at a time until lever is released.

Gear to Gear — Quickly “bump” lever to shift up or down to desired gear. Transmission may skip gears if lever is moved faster than transmission can shift.

Shifting Using Clutch Pedal

IMPORTANT: Clutch pedal must be fully depressed to completely disengage clutch for correct operation.

Gear to Gear — Depress clutch pedal and hold or “bump” lever to shift up or down until desired gear is displayed. Transmission goes into commanded gear when clutch pedal is released.

Transport Shifting

When tractor is in light load condition, the transmission can shift faster by rapidly “bumping” shift lever until the desired transport speed is reached. To reach transport speed quickly from a stop, depress the clutch and “bump” the shift lever to F13. Transmission will shift directly to

F13 when the clutch pedal is released to reach the desired gear. Such as transport, transmission can shift fast by rapidly “bumping” shift lever to reach transport speed.

Press and Hold Shifting

When operator holds the shifter in the up or down position, the transmission will shift through the gears one gear at a time.

Double Shift

The transmission may shift two gears at a time by double “bumping” shift lever to slow down or speed up. A double “bump” down shift is useful in field operations when hitting tough spots. Double “bumping” may also be useful in making headland turns.

Ground Speed Matching

CAUTION: Avoid possible accident and injury from loss of vehicle control. Never coast down hill.

The transmission will shift gears to match ground speed as clutch is released if the tractor is traveling above start up gear or F13 speed.

The transmission will not match ground speeds as clutch is released after the tractor slows when clutch pedal is depressed at gears F13 and below. The transmission will remain above start up gear or F13 even if the tractor comes to a complete stop.

In manual mode, the transmission will not up shift to match ground speed as clutch is released if tractor speeds up while clutch pedal is depressed.

RD47322,00000E2 -19-19AUG13-2/2

Operating e23™ Transmission with Left-Hand Reverser

⚠ CAUTION: Avoid personal injury or damage to tractor. If engine starts with shift lever in gear, there is malfunction of starting circuit. Repair should be made immediately by your John Deere™ Dealer.

IMPORTANT: Prevent transmission or clutch damage:

- Never depress the clutch pedal while tractor is rolling downhill or coasting as transmission may overspeed and cause serious damage to the transmission.
- Never attempt to start tractor by towing or pushing.
- Operator can always move shift lever to PARK Position; however, park brake will not engage until ground speed is below 1.75 km/h (1.0 mph).
- Avoid excessive ballast.
- Avoid continuous operation under full throttle and full load conditions below 1800 rpm.

Place left-hand reverser (A) into desired directional slot.

Shift transmission using lever (B) on CommandARM™.

The transmission can be shifted, without use of clutch pedal, into forward or reverse.

The clutch pedal allows operator maximum manual control of modulation for ease in connecting implements, operating in confined areas, or slow movement of tractor during precise maneuvers.

Depress clutch pedal to preselect forward or reverse direction from park.

When left-hand reverser (A) is moved from PARK to NEUTRAL position, park brake releases and corner post display (C) shows pre-selected forward or reverse gear and letter "N" for NEUTRAL. When lever is in forward or reverse, display shows "F" or an "R" along with commanded gear.

Engine only starts with left-hand reverser (A) is in PARK or NEUTRAL. Shifts are made one at a time by "bumping" lever (B). Multiple bumps or pushing and holding lever forward or pulling and holding lever rearward may result in skip shifts.

NOTE: The seat assembly contains an operator presence safety device to prevent initiation of movement of tractor without operator sitting in seat.

NOTE: When the tractor is loaded to very low engine speed, the transmission may default to NEUTRAL for powertrain protection. The park brake engages once the wheel speed drops below 1.75 km/h (1.0 mph).

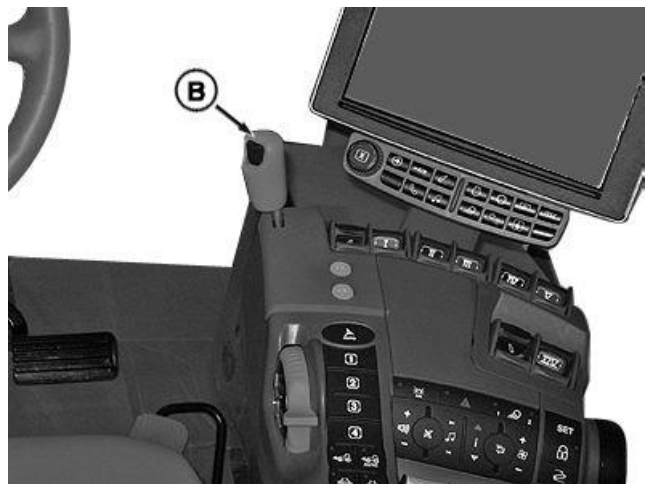

A— Left-Hand Reverser C— Corner Post Display
B— Transmission Shift Lever

To re-engage transmission, move shift lever to PARK, reduce load, and shift into desired operating gear.

A diagnostic trouble code is stored and displayed when this condition occurs.

RXA0130273 —UN—11JAN13

RXA0130274 —UN—26AUG13

RXA0133278 —UN—17JUN13

RD47322,00000B7 -19-24JUN13-1/1

Shifting e23™ Transmission with Left-Hand Reverser

Shift Lever Positions

PARK — Lower left slot (A) — The park brake is applied when lever is fully inward in slot.

NEUTRAL — Middle slot (before Park) (B) — The park brake is released when lever is moved to this slot.

Forward — Upper right slot (C) — The tractor begins moving forward when lever enters this slot. Push lever (E) forward for upshifts (+), pull rearward for downshifts (-).

Reverse — Lower right slot (D) — The tractor begins moving rearward when lever enters this slot. Push lever (E) forward for upshifts (+), pull rearward for downshifts (-).

IMPORTANT: Operator can always move shift lever to PARK Position; however, park brake will not engage until ground speed is below 1.75 km/h (1.0 mph).

Command Gears

NOTE: Optimum engine speed is 1800 — 2200 rpm in full load conditions. Using higher gear and lower engine speed for light load operation saves fuel and reduces wear. Under full load conditions, use full throttle engine speed.

Each time transmission enters forward or reverse shift pattern, transmission starts in command gear, shown on corner post display.

Transmission starts out in F8 and R4 after engine is started. These are default command gears. Startup default command gears may be changed from F1 - F13 in forward and R1 - R6 in reverse (see Setting Start Gear in this section).

Command gear temporarily changes to the last gear used when shuttling between forward and reverse, or shifting from gear to neutral.

Initial command gear can be changed before initiating motion to match operation.

Forward Gear—Gears between F1 and F13 may be preselected by depressing clutch pedal and pushing or pulling shift lever until desired command gear is displayed.

Reverse Gear—Gears between R1 and R6 may be preselected by depressing clutch pedal and pushing or pulling shift lever until desired command gear is displayed.

The transmission will start in the preselected forward or reverse gear when clutch pedal is released.

Cold Weather Starting

When temperature is -10 °C (14°F) or lower, it may take one minute to release park brake with operator in the seat and the transmission shifted into gear. Several shifts between PARK and NEUTRAL may be required to release park in extremely cold conditions.

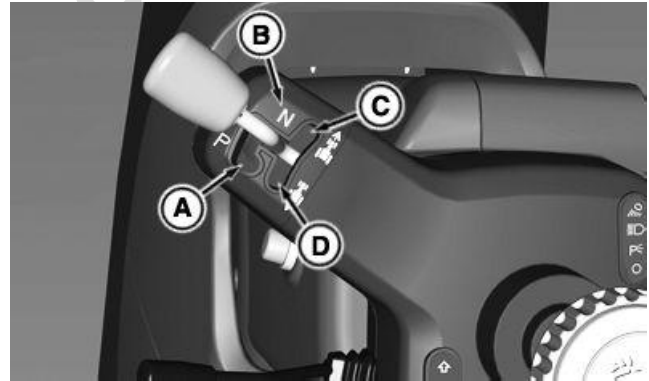

- A— PARK
- B— NEUTRAL
- C— Forward
- D— Reverse
- E— Shift Lever

When temperature is -10 °C (14°F) or above, it may take 3 seconds to release park brake with operator in the seat.

When left hand reverser is moved to NEUTRAL, corner post display shows “N” for three seconds. If park brake does not release, “N” changes back to “P”. Move left hand reverser back to PARK then back to NEUTRAL until “N” displays more than three seconds.

Delayed shifting, slow hydraulic operation, hard steering, and limited engine rpm may also be noticeable until operating temperature is obtained.

Shifting Without Using Clutch Pedal

Gear to Gear — Hold lever to shift up or down until desired gear is reached. The transmission shifts one gear at a time until lever is released.

Gear to Gear — Quickly “bump” lever to shift up or down to desired gear. The transmission may skip gears if lever is moved faster than transmission can shift.

Continued on next page

RD47322,00000B6 -19-19AUG13-1/2

RXA0130292 —UN—11JAN13

RXA0130293 —UN—26AUG13

Shifting Using Clutch Pedal

IMPORTANT: Clutch pedal must be fully depressed to completely disengage clutch for correct operation.

Gear to Gear — Depress clutch pedal and hold or “bump” lever to shift up or down until desired gear is displayed. Transmission goes into displayed gear when clutch pedal is released.

Transport Shifting

When the tractor is in a light load condition, the transmission can shift faster by rapidly “bumping” the shift lever until the desired transport speed is reached. To reach transport speed quickly from a stop, depress the clutch pedal and “bump” the shift lever to F13. The transmission will shift directly to F13 when the clutch pedal is released. Once the tractor is underway in F13, rapidly “bump” the shift lever to reach the desired gear.

Press and Hold Shifting

When operator holds the shifter in the up or down position, the transmission will shift through the gears one gear at a time.

Double Shift

The transmission may shift two gears at a time by double “bumping” shift lever to slow down or speed up. A double “bump” down shift is useful in field operations when hitting tough spots. Double “bumping” may also be useful in making headland turns.

Ground Speed Matching

CAUTION: Avoid possible accident and injury from loss of vehicle control. Never coast down hill.

Transmission will shift gears to match the ground speed as clutch is released if the tractor is traveling above start up gear or F13.

Transmission will not match ground speeds as clutch is released after tractor slows when clutch pedal is depressed at gears F13 and below. The transmission remains in above start up gear or F13 even if tractor comes to complete stop.

In manual mode, the transmission will not up shift to match ground speed as clutch is released if tractor speeds up while clutch pedal is depressed.

RD47322,00000B6 -19-19AUG13-2/2

Setting Startup Gears

RXA0133712 —UN—16JUL13

Press Transmission Shortcut Button on Navigation Bar.

1. Press **Advanced Settings** icon.
2. Press **Settings** tab.
3. Press Forward Startup Gear button (A). List of forward gears appears.
4. Select desired gear and press Done button to finish selection.
5. Press Reverse Startup Gear button (B). List of reverse gears appears.
6. Select desired gear and press Done button to finish selection.



Transmission Shortcut Button on Navigation Bar

RXA0130326 —UN—11JAN13

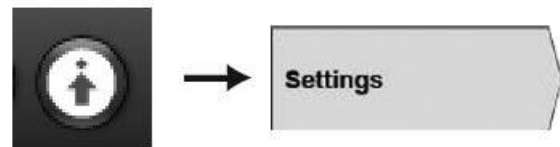

Advanced Settings Icon → Settings Tab

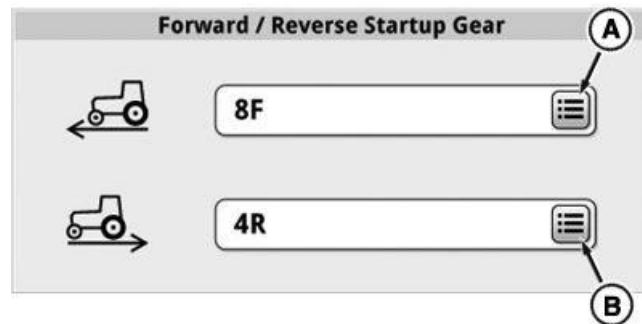

Forward and Reverse Startup Gears

RD47322,00000E3 -19-21AUG13-1/1

RXA0128274 —UN—17SEP12

CommandCenter™ Transmission Main Page

The e23™ transmission offers three modes of operation to optimize fuel efficiency and load control of the tractor. These modes are selected from the CommandCenter™ transmission main page.

- **Full AUTO (A)** — Automatically adjusts engine speed and gear selection to optimize fuel economy and performance. This mode automatically responds to loads created by the hitch or SCV's. During PTO use, engine speed is automatically controlled to provide appropriate PTO speed.
- **Custom (B)** — Similar to Full AUTO mode except the operator can modify some of the limits and parameters used in Full AUTO mode. See custom transmission settings in this section.
- **Manual (C)** — Operator selects engine throttle position and gear.

Maximum Ground Speed

The maximum tractor ground speed may be limited through the transmission main page. Forward maximum speed (D) and reverse maximum speed (E) displays maximum forward and reverse speed limits.

Changing Maximum Ground Speed

Press **Transmission Shortcut Button on Navigation Bar**.

1. Press appropriate speed limit on the Transmission Main page. The value adjustment page appears.
2. Adjust the ground speed to the desired value by using increase (+) and decrease (-) buttons. Also turning adjusting dial (K) can be used to increase or decrease ground speed settings.

NOTE: If operator changes maximum forward or reverse speed below current speed, the set speed (F) decreases to the maximum speed and the vehicle speed will decrease.

Efficiency Manager™ Set Speed

There are two programmable set speeds for each direction used in Efficiency Manager™. They are activated by pushing the set speed buttons on CommandArm™. Once activated, Efficiency Manager™ will shift gears and change engine speed so that the ground speed will match



Transmission Shortcut Button on Navigation Bar

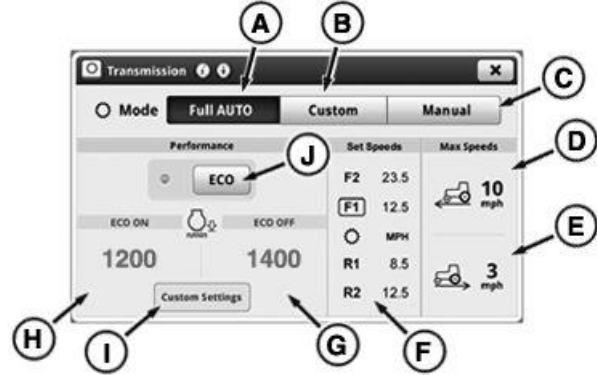

Transmission Main Page



Adjusting Dial

- | | |
|----------------------------------|---------------------------------|
| A— Full AUTO Mode | G— ECO Engine Speed Off Setting |
| B— Custom Mode | H— ECO Engine Speed On Setting |
| C— Manual Mode | I— Custom Settings button |
| D— Maximum Forward Speed Setting | J— ECO Level button |
| E— Maximum Reverse Speed Setting | K— Adjusting Dial |
| F— Set Speeds Module | |

the set speed. The set speeds are changed through the set speed adjusting wheel. (See Efficiency Manager™ in this section.)

Efficiency Manager™ on the e23™ Transmission

Efficiency Manager™ controls transmission gear shifting and engine speed to maintain the desired ground speed (set speed). Shift decisions are based on load conditions, throttle command, and operator settings.

- Efficiency Manager™ is always running in **Full AUTO** and **Custom** modes.
- Efficiency Manager™ runs in Manual Mode when the set speed buttons are active.

Using Efficiency Manager™

- The Efficiency Manager™ indicator light (C) is on the corner post display.
- The tractor will only reach the set speed if the engine throttle is set to maximum engine rpm.
- In high load applications, the throttle should be set to maximum rpm.
- The transmission may shift gears if either the hand throttle or foot throttle is changed.
- The operator has a choice of setting two separate set speeds.
- The set speed is adjusted on the active set speed button by using the set speed adjusting wheel (A) on the shift lever. Press either set speed button 1 or 2, then rotate set speed adjusting wheel clockwise to increase speed and counterclockwise to decrease set speed. Repeat process for setting the second set speed. The transmission may shift gears with changes in set speed.
- Bumping the shift lever when in **Full AUTO** and in **Custom** modes, temporarily makes a large change in the set speed. The transmission may shift gears and the engine speed may change. The speeds stored in the set speed buttons (B) do not change.
- Efficiency Manager™ will not shift gears if the clutch pedal is partially depressed.
- If the clutch pedal is fully depressed and the tractor is stationary, Efficiency Manager™ selects the start-up gear and may reduce the engine speed.
- Efficiency Manager will select the start-up gear when shifting from neutral or park to gear.
- If the clutch pedal is fully depressed and the tractor is moving above the start-up gear speed, Efficiency Manager™ selects a gear and engine speed to match the ground speed.
- If the clutch pedal is fully depressed and the tractor is moving below the start-up gear speed, Efficiency Manager™ selects the start-up gear speed.

NOTE: Efficiency Manager™ set speeds can be programmed into iTEC™,

A— Set Speed Adjusting Wheel **C**— Efficiency Manager Indicator Light
B— Set Speed Buttons



Set Speed Buttons with RH Reverser



Set Speed Buttons with LH Reverser



Efficiency Manager Indicator Light

Efficiency Manager is a trademark of Deere & Company
 iTEC is a trademark of Deere & Company

RXA0132341—UN—02MAY13

RXA0132342—UN—02MAY13

RXA0135363—UN—03SEP13

RD47322.00000E5 -19-14AUG13-1/1

Efficiency Manager™ on e23™ Transmission in Manual Mode

Efficiency Manager™ is activated in **Manual Mode** by pressing either of the set speed buttons (A) on the CommandArm™.

- Pressing the same set speed button a second time in **Manual Mode** will disengage Efficiency Manager™.
- Bumping the shift lever in **Manual Mode** when efficiency manager is active, disengages Efficiency Manager™, shifts gears and changes engine speed to match the engine throttle position.
- All other features and functions of Efficiency Manager™ are the same between Full AUTO Mode and Custom Mode.

IMPORTANT: When disabling Efficiency Manager™, the engine rpm changes to match throttle position, possibly resulting in tractor acceleration.

A— Set Speed Buttons



RXA0131632—UN—26MAR13

Speed Buttons with RH Reverser



RXA0131631—UN—26MAR13

Speed Buttons with LH Reverser

RD47322.00001CA -19-24JUN13-1/1

PROOF

Custom Transmission Settings

NOTE: Settings on this page can only be modified when Efficiency Manager is in Custom or Manual Mode.

Auto Shift Engine Speed Droop (D) and (E) limits the engine speed droop under full load before Efficiency Manager™ automatically downshifts. A lower percentage means less droop is allowed before downshifting.

NOTE: Auto Shift Engine Speed Droop can be set from 6% —26%. Different values may be entered for operation with or without the PTO.

Press **Transmission Shortcut Button on Navigation Bar**.

On Mode bar, select **Custom or Manual Mode**.

Setting Auto Shift Engine Droop

NOTE: Auto Shift Engine Speed Droop PTO ON can be set from 6% —26 %.

- Select Custom Settings button (A).
- Select Auto Shift Engine Speed Droop PTO ON module (D). Value adjustment page appears.
- Adjust percentage value to desired value by using increase (+) and decrease (-) buttons.

Minimum Engine speed (B) and (C) limits how much Efficiency Manager™ shifts up and throttles back to save fuel under light loads.

Minimum Engine Speed

NOTE: Auto Shift Engine Speed Droop PTO OFF can be set from 14% — 26 %.

- From Transmission page, select Custom Settings button (A).
- Select Auto Shift Engine Speed Droop PTO ON (D) or Auto Shift Engine Speed Droop PTO OFF (E). Value adjustment page will appear.
- Adjust percentage value to desired value by using increase (+) and decrease (-) buttons.

Turn Load Anticipation ON

- From Transmission page, select Custom Settings button (A).
- Use Hitch Load Anticipation toggle (F), SCV Load Anticipation toggle (G) or PTO Load Anticipation toggle (H) to turn hitch, SCV or PTO load anticipation ON or OFF.

RXA0133712 —UN—16JUL13



Transmission Shortcut Button on Navigation Bar

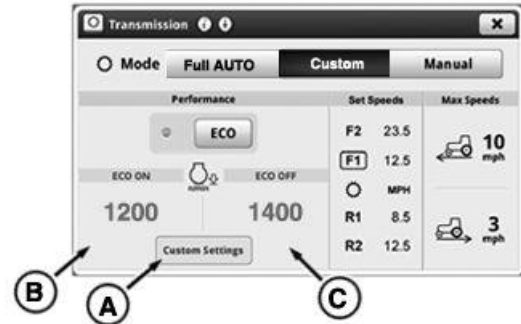

Transmission Home Page

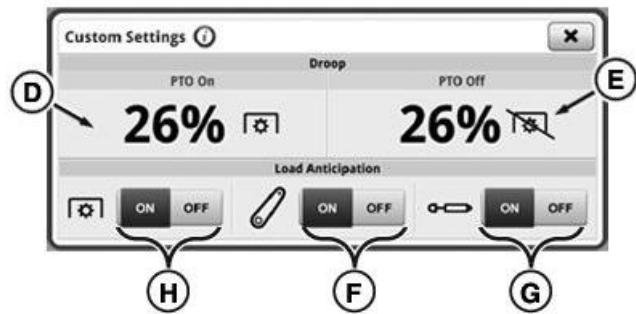

Custom Settings Page

- A— Custom Settings button
- B— ECO Engine Speed ON Setting
- C— ECO Engine Speed OFF Setting
- D— Engine Droop PTO ON Setting
- E— Engine Droop PTO OFF Setting
- F— Hitch Load Anticipation Toggle
- G— SCV Load Anticipation Toggle
- H— PTO Load Anticipation Toggle

RXA0130885 —UN—11FEB13

RXA0130327 —UN—11JAN13

RD47322.00000E6 -19-19AUG13-1/1

Operating IVT™/AutoPowr™ Transmission

Controls Identification

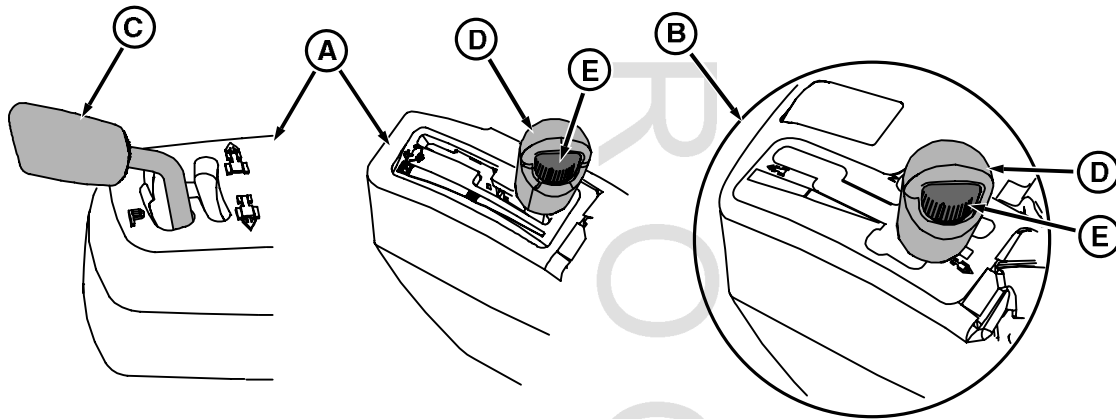

AutoPowr™ Controls

- A—Left-Hand Reverser Controls** **C—Left-Hand Reverser Lever** **E—Set Speed Adjusting Wheel**
B—Right-Hand Reverser **D—Speed Control Lever**

AutoPowr™ transmission provides infinite ground speeds in forward mode from 50 meters per hour (164 feet per hour) to 50 km/h (31 mph) depending on tractor specifications. Reverse mode provides infinite ground speeds from 50 meters per hour (164 feet per hour) to 20 km/h (12.4 mph). Maximum speeds may vary slightly due to tire size.

AutoPowr™ tractors are equipped with either left-hand reverser or right-hand reverser. Left-hand configuration requires two levers. Left-hand reverser lever (C) controls tractor direction, park and neutral. Speed control lever (D), is located on CommandARM™ and controls ground speed.

Right-hand reverser option consists of right-hand reverser lever (B) located on CommandARM™ and controls tractor direction, park, neutral, and ground speed.

AutoPowr is a trademark of Deere & Company

There are two variable speed bands in forward direction on all tractors. Tractors equipped with left-hand reverser have two-speed bands in reverse. Tractors equipped with right-hand reverser have single reverse band.

Set speeds are maximum ground speeds in each speed band. Speed control lever must be pushed to end of slot to achieve set speeds. Rotate set speed adjusting wheel (E) clockwise to increase speed and counterclockwise to decrease set speed.

RXA0127892 —UN—29AUG12

RD47322,00000E7 -19-24JUN13-1/1

Left-Hand and Right-Hand Reverser Shift Patterns

Park (A): Engages park brake to hold tractor stationary preventing tractor from rolling; "P" appears on corner post display.

Neutral (B): Disengages park brake, allowing tractor to roll, but does not transmit power to wheels; "N" appears on corner post display.

Reverse (C): Transmits power to wheels for rearward travel; "R" appears on corner post display.

Power Zero™ (D): Hand-held zero position temporarily holds tractor stationary on relatively flat surface.

Scroll Position (E): Scrolls through set speeds on corner post display continuously while tractor is not moving.

Forward Speed Band 1 (F): Transmits power to wheels for forward travel; "F1" appears on corner post display.

Forward Speed Band 2 (G): Transmits power to wheels for forward travel; "F2" appears on corner post display.

Forward (H): Transmits power to wheels for forward travel; "F" appears on corner post display.

Minimum Speed (I): Transmits power to wheels in direction selected.

- | | |
|-------------------|------------------------|
| A—Park | F—Forward Speed Band 1 |
| B—Neutral | G—Forward Speed Band 2 |
| C—Reverse | H—Forward |
| D—Power Zero™ | I—Minimum Speed |
| E—Scroll Position | |

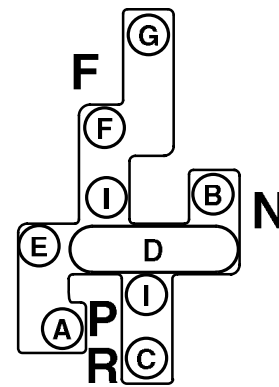

Right-Hand Reverser

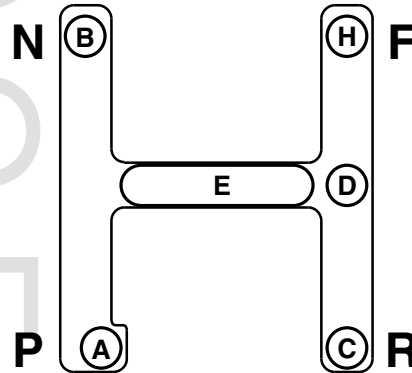

Left-Hand Reverser

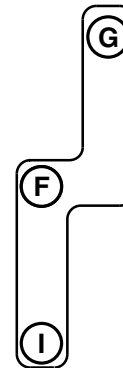

Left-Hand Reverser Speed Lever

RXA0133408—UN—13AUG13

RXA0100319—UN—26JAN09

RXA0077571—UN—10JUN05

RD47322,00000E8 -19-27JUN13-1/1

Operating the Transmission

⚠ CAUTION: Avoid personal injury or damage to tractor. If engine starts with lever not in PARK position, there is a malfunction in the starting circuit. Repairs should be made by John Deere™ dealers.

IMPORTANT: Prevent transmission or clutch damage:

- Never depress clutch pedal while tractor is rolling downhill or coasting, as serious transmission damage may result.
- Never attempt to start tractor by towing or pushing.
- Operator can always move shift lever to PARK Position; however, park brake will not engage until ground speed is below 1.75 km/h (1.0 mph).
- Avoid excessive ballast.
- Clutch pedal must be fully depressed to completely disengage clutch. Never rest foot on clutch pedal while tractor is moving.

NOTE: Operator presence safety device is built into seat to prevent movement of tractor while in gear without operator sitting in seat.

Starting Engine

John Deere is a trademark of Deere & Company

IMPORTANT: Tractor with left-hand reverser can start in neutral.

Tractors with right-hand reverser cannot start in neutral. If tractor does start in neutral, contact John Deere™ dealer for repair.

Ensure transmission is in PARK position; corner post monitor will display "P" for park. Start engine.

Stopping Engine

For tractors with left-hand reverser, reduce engine speed to low rpm, pull speed control lever back to slowest setting and depress brake pedals until travel stops. Move left-hand reverser lever to PARK position. Slowly release brakes and stop engine.

For tractors with right-hand reverser, reduce engine speed to low rpm, pull right-hand reverser lever back to slowest setting and depress brake pedals until travel stops. Move right-hand reverser lever to PARK position. Slowly release brakes and stop engine.

⚠ CAUTION: Always place reverser lever in PARK position before dismounting tractor.

P
R
O
O
F

RD47322.00000E9 -19-26AUG13-1/1