

## FCC Test Report

**Report No.:** RF171204D02

**FCC ID:** 2AAFMRGP0050

**Test Model:** RGP0050

**Received Date:** Dec. 4, 2017

**Test Date:** Dec. 6 ~ 12, 2017

**Issued Date:** Jan. 2, 2018

**Applicant:** Corsair Memory, Inc.

**Address:** 47100 Bayside Pkwy, Fremont, CA 94538, USA

**Issued By:** Bureau Veritas Consumer Products Services (H.K.) Ltd., Taoyuan Branch

**Lab Address:** No. 47-2, 14th Ling, Chia Pau Vil., Lin Kou Dist., New Taipei City, Taiwan (R.O.C.)

**FCC Registration /  
Designation Number:** 198487 / TW2021



This report is for your exclusive use. Any copying or replication of this report to or for any other person or entity, or use of our name or trademark, is permitted only with our prior written permission. This report sets forth our findings solely with respect to the test samples identified herein. The results set forth in this report are not indicative or representative of the quality or characteristics of the lot from which a test sample was taken or any similar or identical product unless specifically and expressly noted. Our report includes all of the tests requested by you and the results thereof based upon the information that you provided to us. You have 60 days from date of issuance of this report to notify us of any material error or omission caused by our negligence, provided, however, that such notice shall be in writing and shall specifically address the issue you wish to raise. A failure to raise such issue within the prescribed time shall constitute your unqualified acceptance of the completeness of this report, the tests conducted and the correctness of the report contents. Unless specific mention, the uncertainty of measurement has been explicitly taken into account to declare the compliance or non-compliance to the specification. The report must not be used by the client to claim product certification, approval, or endorsement by TAF or any government agencies.

## Table of Contents

<b>Release Control Record</b> .....	<b>3</b>
<b>1 Certificate of Conformity</b> .....	<b>4</b>
<b>2 Summary of Test Results</b> .....	<b>5</b>
2.1 Measurement Uncertainty .....	5
2.2 Modification Record .....	5
<b>3 General Information</b> .....	<b>6</b>
3.1 General Description of EUT .....	6
3.2 Description of Test Modes .....	7
3.2.1 Test Mode Applicability and Tested Channel Detail .....	8
3.3 Description of Support Units .....	9
3.3.1 Configuration of System under Test .....	9
3.4 General Description of Applied Standards .....	10
<b>4 Test Types and Results</b> .....	<b>11</b>
4.1 Radiated Emission and Bandedge Measurement.....	11
4.1.1 Limits of Radiated Emission and Bandedge Measurement .....	11
4.1.2 Test Instruments .....	12
4.1.3 Test Procedures.....	13
4.1.4 Deviation from Test Standard .....	13
4.1.5 Test Set Up .....	14
4.1.6 EUT Operating Conditions.....	14
4.1.7 Test Results .....	15
4.2 Conducted Emission Measurement .....	21
4.2.1 Limits of Conducted Emission Measurement .....	21
4.2.2 Test Instruments .....	21
4.2.3 Test Procedures.....	22
4.2.4 Deviation from Test Standard .....	22
4.2.5 Test Setup.....	22
4.2.6 EUT Operating Conditions.....	22
4.2.7 Test Results .....	23
4.3 Channel Bandwidth .....	27
4.3.1 Test Setup.....	27
4.3.2 Test Instruments .....	27
4.3.3 Test Procedure .....	27
4.3.4 Deviation from Test Standard .....	27
4.3.5 EUT Operating Condition .....	27
4.3.6 Test Results .....	28
4.4 Occupied Bandwidth Measurement .....	29
4.4.1 Test SetUp .....	29
4.4.2 Test Instruments .....	29
4.4.3 Test Procedure .....	29
4.4.4 Deviation from Test Standard .....	29
4.4.5 EUT Operating Conditions.....	29
4.4.6 Test Results .....	30
<b>5 Pictures of Test Arrangements</b> .....	<b>31</b>
<b>Appendix – Information on the Testing Laboratories</b> .....	<b>32</b>

### Release Control Record

Issue No.	Description	Date Issued
RF171204D02	Original release.	Jan. 2, 2018



## 2 Summary of Test Results

47 CFR FCC Part 15, Subpart C (SECTION 15.209)			
FCC Clause	Test Item	Result	Remarks
15.207	AC Power Conducted Emission	PASS	Meet the requirement of limit. Minimum passing margin is -11.85dB at 0.87266MHz.
15.209	Radiated Emission Test	PASS	Meet the requirement of limit. Minimum passing margin is -6.17dB at 51.340MHz.
15.215	Channel Bandwidth Measurement	PASS	Meet the requirement.
-	Occupied Bandwidth Measurement	PASS	Meet the requirement of limit.

### 2.1 Measurement Uncertainty

Where relevant, the following measurement uncertainty levels have been estimated for tests performed on the EUT as specified in CISPR 16-4-2:

Measurement	Frequency	Expanded Uncertainty (k=2) ( $\pm$ )
Conducted Emissions at mains ports	150kHz ~ 30MHz	2.77 dB
Radiated Emissions up to 1 GHz	9kHz ~ 30MHz	2.38 dB
	30MHz ~ 1000MHz	5.54 dB

### 2.2 Modification Record

There were no modifications required for compliance.

### 3 General Information

#### 3.1 General Description of EUT

Product	USB Device
Brand	Corsair
Test Model	RGP0050
Status of EUT	Engineering Sample
PTU Version	1.2.2
Power Supply Rating	5Vdc, 0.5A, 2.5W
Modulation Type	FSK Modulation
Operating Frequency	110-205kHz
Tested Frequency	114kHz, 139kHz, 150kHz
Antenna Type	Coil antenna
Antenna Connector	N/A
Accessory Device	N/A
Data Cable Supplied	N/A

Note:

1. EUT is a Wireless Charger with Qi charging function.
2. The above EUT information is declared by manufacturer and for more detailed features description, please refer to the manufacturer's specifications or user's manual.

### 3.2 Description of Test Modes

3 channels are provided to this EUT:

Channel	Frequency (kHz)	Load
1	139	10% Load
2	150	50% Load
3	114	90% Load

### 3.2.1 Test Mode Applicability and Tested Channel Detail

EUT CONFIGURE MODE	APPLICABLE TO			DESCRIPTION
	RE<1G	PLC	APCM	
A	√	√	√	Charging Mode (EUT + Notebook)
B	-	√	-	Charging Mode (EUT + Adapter)

Where **RE<1G**: Radiated Emission below 1GHz      **PLC**: Power Line Conducted Emission  
**APCM**: Antenna Port Conducted Measurement

#### **Radiated Emission Test (Below 1GHz):**

- Pre-Scan has been conducted to determine the worst-case mode from all possible combinations between available modulations, data rates and antenna ports (if EUT with antenna diversity architecture).
- Following channel(s) was (were) selected for the final test as listed below.

EUT CONFIGURE MODE	AVAILABLE CHANNEL	TESTED CHANNEL
A	1 to 3	1, 2, 3

#### **Power Line Conducted Emission Test:**

- Pre-Scan has been conducted to determine the worst-case mode from all possible combinations between available modulations, data rates and antenna ports (if EUT with antenna diversity architecture).
- Following channel(s) was (were) selected for the final test as listed below.

EUT CONFIGURE MODE	AVAILABLE CHANNEL	TESTED CHANNEL
A & B	1 to 3	3

#### **Antenna Port Conducted Measurement:**

- Pre-Scan has been conducted to determine the worst-case mode from all possible combinations between available modulations, data rates and antenna ports (if EUT with antenna diversity architecture).
- Following channel(s) was (were) selected for the final test as listed below.

EUT CONFIGURE MODE	AVAILABLE CHANNEL	TESTED CHANNEL
A & B	1 to 3	1, 2, 3

#### **Test Condition:**

APPLICABLE TO	EUT CONFIGURE MODE	ENVIRONMENTAL CONDITIONS	INPUT POWER	TESTED BY
PLC	A	17deg. C, 75% RH	120Vac, 60Hz (Notebook)	StarItaly Wu
	B	17deg. C, 75% RH	120Vac, 60Hz (Adapter)	StarItaly Wu
RE<1G	A	19deg. C, 77% RH	120Vac, 60Hz (Notebook)	James Wei
APCM	A	19deg. C, 77% RH	120Vac, 60Hz (Notebook)	James Wei



### 3.3 Description of Support Units

The EUT has been tested as an independent unit together with other necessary accessories or support units. The following support units or accessories were used to form a representative test configuration during the tests.

ID	Product	Brand	Model No.	Serial No.	FCC ID	Remarks
A.	Adapter	HTC	TC-E250	N/A	N/A	Provided by Lab
B.	Notebook PC	ASUS	PU401L	E9NXCBC002007 372	N/A	Provided by Lab
C.	Load	5W, 10ΩJ	N/A	N/A	N/A	Provided by Lab
D.	Load	5W, 15ΩJ, 5W, 10ΩJ	N/A	N/A	N/A	Provided by Lab
E.	Load	5W, 50ΩJ	N/A	N/A	N/A	Provided by Lab
F.	Wireless receiver	Corsair	RGP0069	N/A	2AAFMRGP0069	Supplied by client

Note: All power cords of the above support units are non-shielded (1.8m).

ID	Descriptions	Qty.	Length (m)	Shielding (Yes/No)	Cores (Qty.)	Remarks
1.	Y Type USB cable	1	1.5	Y	0	Supplied by client

Note: The core(s) is(are) originally attached to the cable(s).

#### 3.3.1 Configuration of System under Test

Mode A:

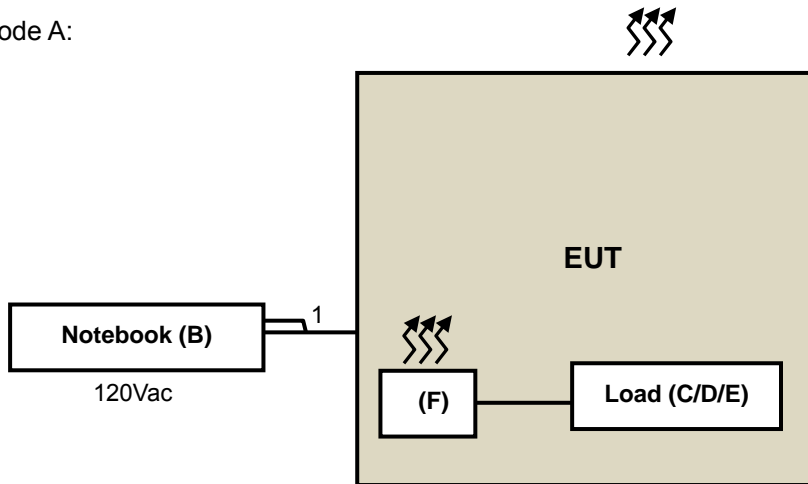

Mode B:

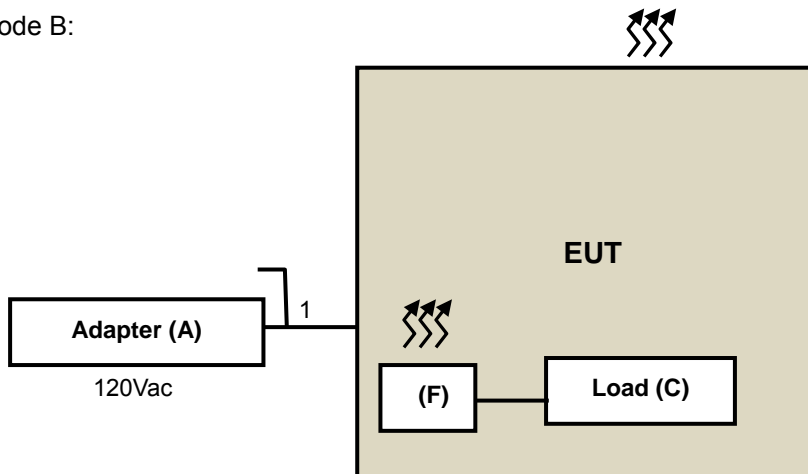

### 3.4 General Description of Applied Standards

The EUT is a RF Product. According to the specifications of the manufacturer, it must comply with the requirements of the following standards:

**FCC Part 15, Subpart C (15.209)**

ANSI C63.10-2013

All test items have been performed and recorded as per the above standards.

## 4 Test Types and Results

### 4.1 Radiated Emission and Bandedge Measurement

#### 4.1.1 Limits of Radiated Emission and Bandedge Measurement

##### FOR FREQUENCY BELOW 30MHz

FREQUENCY (MHz)	FIELD STRENGTH (dBuV/m)		MEASUREMENT DISTANCE (meters)
	uV/m	dBuV/m	
0.009 – 0.490	2400 / F (kHz)	48.52-13.80	300
0.490 – 1.705	24000 / F (kHz)	33.80-22.97	30
1.705 – 30.0	30	29.54	30

##### FOR FREQUENCY BETWEEN 30-1000MHz

FREQUENCY (MHz)	Class A (at 10m)		Class B (at 3m)	
	uV/m	dBuV/m	uV/m	dBuV/m
30-88	90	39.1	100	40.0
88-216	150	43.5	150	43.5
216-960	210	46.4	200	46.0
Above 960	300	49.5	500	54.0

## 4.1.2 Test Instruments

DESCRIPTION & MANUFACTURER	MODEL NO.	SERIAL NO.	CALIBRATED DATE	CALIBRATED UNTIL
HP Preamplifier	8447D	2432A03504	Feb. 21, 2017	Feb. 20, 2018
HP Preamplifier	8449B	3008A01201	Feb. 22, 2017	Feb. 21, 2018
MITEQ Preamplifier	AMF-6F-260400-33-8P	892164	Feb. 21, 2017	Feb. 20, 2018
Agilent TEST RECEIVER	N9038A	MY51210129	Feb. 8, 2017	Feb. 7, 2018
Schwarzbeck Antenna	VULB 9168	139	Dec. 13, 2016	Dec. 12, 2017
Schwarzbeck Antenna	VHBA 9123	480	May 19, 2017	May 18, 2019
Schwarzbeck Horn Antenna	BBHA-9170	212	Dec. 30, 2016	Dec. 29, 2017
Schwarzbeck Horn Antenna	BBHA 9120-D1	D130	Dec. 27, 2016	Dec. 26, 2017
ADT. Turn Table	TT100	0306	NA	NA
ADT. Tower	AT100	0306	NA	NA
Software	Radiated_V7.6.15.9.5	NA	NA	NA
SUHNER RF cable With 4dB PAD	SF104	CABLE-CH6	Aug. 14, 2017	Aug. 13, 2018
SUHNER RF cable With 3dB PAD	SF102	Cable-CH8-3.6m	Aug. 14, 2017	Aug. 13, 2018
KEYSIGHT MIMO Powermeasurement Test set	U2021XA	U2021XA-001	May 31, 2017	May 30, 2018
KEYSIGHT Spectrum Analyzer	N9030A	MY54490260	Jul. 26, 2017	Jul. 25, 2018
Loop Antenna EMCI	LPA600	270	Aug. 11, 2017	Aug. 10, 2019
ROHDE & SCHWARZ Spectrum Analyzer	FSV40	101042	Sep. 29, 2017	Sep. 28, 2018

- NOTE:**
1. The calibration interval of the above test instruments is 12/24 months. And the calibrations are traceable to NML/ROC and NIST/USA.
  2. The horn antenna and HP preamplifier (model: 8449B) are used only for the measurement of emission frequency above 1GHz if tested.
  3. The test was performed in Chamber No. 6.
  4. The Industry Canada Reference No. IC 7450E-6.
  5. The FCC Designation Number is TW2021.

#### 4.1.3 Test Procedures

##### For Frequency range 9kHz~30MHz

- a. The EUT was placed on the top of a rotating table 0.8 meters above the ground at a 3 meter chamber room. The table was rotated 360 degrees to determine the position of the highest radiation.
- b. The EUT was set 3 meters away from the interference-receiving antenna, which was mounted on the top of a variable-height antenna tower.
- c. Both X and Y axes of the antenna are set to make the measurement.
- d. For each suspected emission, the EUT was arranged to its worst case and the rotatable table was turned from 0 degrees to 360 degrees to find the maximum reading.
- e. The test-receiver system was set to Quasi-Peak Detect Function and Specified Bandwidth with Maximum Hold Mode.
- f. For the frequency bands 9–90kHz, 110–490kHz and above 1000 MHz. Radiated emission limits in these three bands are based on measurements employing an average detector.

**NOTE:** The resolution bandwidth and video bandwidth of test receiver/spectrum analyzer is 9kHz at frequency below 30MHz.

##### For Frequency range 30 ~ 1000MHz

- a. The EUT was placed on the top of a rotating table 0.8 meters (for below 1GHz) / 1.5 meters (for above 1GHz) above the ground at 3 meter chamber room for test. The table was rotated 360 degrees to determine the position of the highest radiation.
- b. The EUT was set 3 meters away from the interference-receiving antenna, which was mounted on the top of a variable-height antenna tower.
- c. The height of antenna is varied from one meter to four meters above the ground to determine the maximum value of the field strength. Both horizontal and vertical polarizations of the antenna are set to make the measurement.
- d. For each suspected emission, the EUT was arranged to its worst case and then the antenna was tuned to heights from 1 meter to 4 meters and the rotatable table was turned from 0 degrees to 360 degrees to find the maximum reading.
- e. The test-receiver system was set to quasi-peak detect function and specified bandwidth with maximum hold mode when the test frequency is below 1 GHz.
- f. The test-receiver system was set to peak and average detect function and specified bandwidth with maximum hold mode when the test frequency is above 1 GHz. If the peak reading value also meets average limit, measurement with the average detector is unnecessary.

**Note:**

1. The resolution bandwidth and video bandwidth of test receiver/spectrum analyzer is 120kHz for Quasi-peak detection (QP) at frequency below 1GHz.
2. All modes of operation were investigated and the worst-case emissions are reported.

#### 4.1.4 Deviation from Test Standard

No deviation.

#### 4.1.5 Test Set Up

##### For Frequency range 9kHz~30MHz

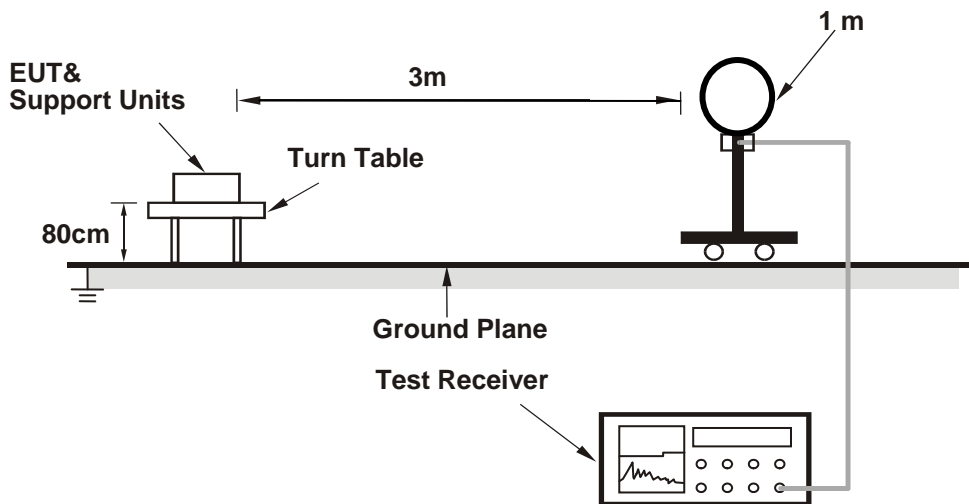

##### For Frequency range 30 ~ 1000MHz

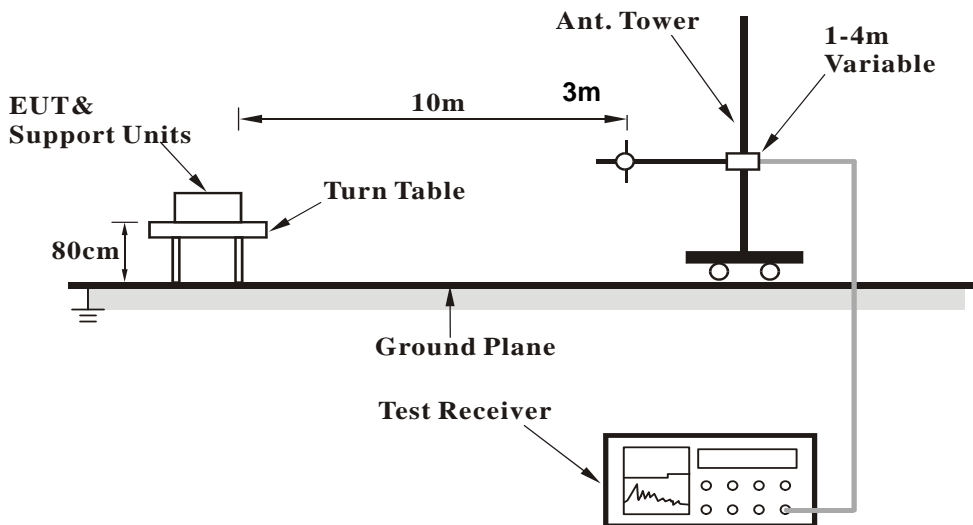

For the actual test configuration, please refer to the attached file (Test Setup Photo).

#### 4.1.6 EUT Operating Conditions

- a. Connected the Adapter or Notebook to EUT.
- b. EUT charged to Lode via Wireless receiver continuously.

#### 4.1.7 Test Results

##### Below 30MHz Data:

<b>CHANNEL</b>	TX Channel 1	<b>DETECTOR FUNCTION</b>	Quasi-Peak & Average
<b>FREQUENCY RANGE</b>	9kHz ~ 30MHz	<b>TEST MODE</b>	Mode A

ANTENNA POLARITY & TEST DISTANCE: LOOP ANTENNA OPEN AT 3 M								
NO.	FREQ. (MHz)	EMISSION LEVEL (dBuV/m)	LIMIT (dBuV/m)	MARGIN (dB)	ANTENNA HEIGHT (m)	TABLE ANGLE (Degree)	RAW VALUE (dBuV)	CORRECTION FACTOR (dB/m)
1	*0.139	76.11 AV	104.74	-28.63	1.00	105	61.78	14.33
2	0.278	48.58 AV	98.72	-50.14	1.00	153	40.25	8.33
3	0.417	51.84 AV	95.20	-43.36	1.00	301	46.53	5.31
4	0.556	37.32 QP	72.70	-35.38	1.00	39	33.74	3.58
5	9.126	25.86 QP	69.54	-43.68	1.00	177	29.69	-3.83
6	22.862	23.38 QP	69.54	-46.16	1.00	108	29.24	-5.86

ANTENNA POLARITY & TEST DISTANCE: LOOP ANTENNA CLOSE AT 3 M								
NO.	FREQ. (MHz)	EMISSION LEVEL (dBuV/m)	LIMIT (dBuV/m)	MARGIN (dB)	ANTENNA HEIGHT (m)	TABLE ANGLE (Degree)	RAW VALUE (dBuV)	CORRECTION FACTOR (dB/m)
1	*0.139	65.59 AV	104.74	-39.15	1.00	129	51.26	14.33
2	0.278	47.77 AV	98.72	-50.95	1.00	59	39.44	8.33
3	0.417	43.20 AV	95.20	-52.00	1.00	74	37.89	5.31
4	0.556	37.75 QP	72.70	-34.95	1.00	233	34.17	3.58
5	6.787	25.85 QP	69.54	-43.69	1.00	255	29.35	-3.50
6	19.803	26.03 QP	69.54	-43.51	1.00	109	31.08	-5.05

#### REMARKS:

- Emission Level(dBuV/m) = Raw Value(dBuV) + Correction Factor(dB/m)
- Correction Factor(dB/m) = Antenna Factor(dB/m) + Cable Factor(dB) – Pre-Amplifier Factor(dB)
- The other emission levels were very low against the limit.
- Margin value = Emission Level – Limit value
- " \* ": Fundamental frequency.
- Loop antenna was used for all radiated emission below 30MHz.
- Limit @3m=Limit@300m+40log(300 / 3)=Limit@300m+80
- Limit @3m=Limit@30m+40log(30 / 3)=Limit@30m+40

<b>CHANNEL</b>	TX Channel 2	<b>DETECTOR FUNCTION</b>	Quasi-Peak & Average
<b>FREQUENCY RANGE</b>	9kHz ~ 30MHz	<b>TEST MODE</b>	Mode A

ANTENNA POLARITY & TEST DISTANCE: LOOP ANTENNA OPEN AT 3 M								
NO.	FREQ. (MHz)	EMISSION LEVEL (dBuV/m)	LIMIT (dBuV/m)	MARGIN (dB)	ANTENNA HEIGHT (m)	TABLE ANGLE (Degree)	RAW VALUE (dBuV)	CORRECTION FACTOR (dB/m)
1	*0.150	74.44 AV	104.08	-29.64	1.00	211	60.75	13.69
2	0.300	52.65 AV	98.06	-45.41	1.00	44	45.03	7.62
3	0.450	52.54 AV	94.54	-42.00	1.00	318	47.65	4.89
4	0.600	41.48 QP	72.04	-30.56	1.00	281	38.43	3.05
5	10.086	26.58 QP	69.54	-42.96	1.00	101	30.44	-3.86
6	29.520	24.96 QP	69.54	-44.58	1.00	307	25.33	-0.37
ANTENNA POLARITY & TEST DISTANCE: LOOP ANTENNA CLOSE AT 3 M								
NO.	FREQ. (MHz)	EMISSION LEVEL (dBuV/m)	LIMIT (dBuV/m)	MARGIN (dB)	ANTENNA HEIGHT (m)	TABLE ANGLE (Degree)	RAW VALUE (dBuV)	CORRECTION FACTOR (dB/m)
1	*0.150	63.88 AV	104.08	-40.20	1.00	144	50.19	13.69
2	0.300	47.87 AV	98.06	-50.19	1.00	107	40.25	7.62
3	0.450	45.81 AV	94.54	-48.73	1.00	312	40.92	4.89
4	0.600	40.78 QP	72.04	-31.26	1.00	286	37.73	3.05
5	7.507	27.77 QP	69.54	-41.77	1.00	109	31.31	-3.54
6	19.683	26.82 QP	69.54	-42.72	1.00	277	31.88	-5.06

**REMARKS:**

1. Emission Level(dBuV/m) = Raw Value(dBuV) + Correction Factor(dB/m)
2. Correction Factor(dB/m) = Antenna Factor(dB/m) + Cable Factor(dB) – Pre-Amplifier Factor(dB)
3. The other emission levels were very low against the limit.
4. Margin value = Emission Level – Limit value
5. " \* ": Fundamental frequency.
6. Loop antenna was used for all radiated emission below 30MHz.
7. Limit @3m=Limit@300m+40log(300 / 3)=Limit@300m+80
8. Limit @3m=Limit@30m+40log(30 / 3)=Limit@30m+40



<b>CHANNEL</b>	TX Channel 3	<b>DETECTOR FUNCTION</b>	Quasi-Peak & Average
<b>FREQUENCY RANGE</b>	9kHz ~ 30MHz	<b>TEST MODE</b>	Mode A

ANTENNA POLARITY & TEST DISTANCE: LOOP ANTENNA OPEN AT 3 M								
NO.	FREQ. (MHz)	EMISSION LEVEL (dBuV/m)	LIMIT (dBuV/m)	MARGIN (dB)	ANTENNA HEIGHT (m)	TABLE ANGLE (Degree)	RAW VALUE (dBuV)	CORRECTION FACTOR (dB/m)
1	*0.114	79.35 AV	106.47	-27.12	1.00	144	63.58	15.77
2	0.228	52.01 AV	100.45	-48.44	1.00	294	42.10	9.91
3	0.342	57.05 AV	96.92	-39.87	1.00	139	50.31	6.74
4	0.456	42.93 AV	94.42	-51.49	1.00	260	38.12	4.81
5	8.346	26.09 QP	69.54	-43.45	1.00	177	29.77	-3.68
6	29.580	27.99 QP	69.54	-41.55	1.00	109	28.16	-0.17
ANTENNA POLARITY & TEST DISTANCE: LOOP ANTENNA CLOSE AT 3 M								
NO.	FREQ. (MHz)	EMISSION LEVEL (dBuV/m)	LIMIT (dBuV/m)	MARGIN (dB)	ANTENNA HEIGHT (m)	TABLE ANGLE (Degree)	RAW VALUE (dBuV)	CORRECTION FACTOR (dB/m)
1	*0.114	69.85 AV	106.47	-36.62	1.00	214	54.08	15.77
2	0.228	51.31 AV	100.45	-49.14	1.00	103	41.40	9.91
3	0.342	46.84 AV	96.92	-50.08	1.00	81	40.10	6.74
4	0.456	42.35 AV	94.42	-52.07	1.00	227	37.54	4.81
5	8.886	27.03 QP	69.54	-42.51	1.00	324	30.83	-3.80
6	20.403	26.08 QP	69.54	-43.46	1.00	311	31.13	-5.05

**REMARKS:**

1. Emission Level(dBuV/m) = Raw Value(dBuV) + Correction Factor(dB/m)
2. Correction Factor(dB/m) = Antenna Factor(dB/m) + Cable Factor(dB) – Pre-Amplifier Factor(dB)
3. The other emission levels were very low against the limit.
4. Margin value = Emission Level – Limit value
5. " \* ": Fundamental frequency.
6. Loop antenna was used for all radiated emission below 30MHz.
7. Limit @3m=Limit@300m+40log(300 / 3)=Limit@300m+80
8. Limit @3m=Limit@30m+40log(30 / 3)=Limit@30m+40

**Below 1GHz Data:**

<b>CHANNEL</b>	TX Channel 1	<b>DETECTOR FUNCTION</b>	Quasi-Peak (QP)
<b>FREQUENCY RANGE</b>	30MHz ~ 1GHz	<b>TEST MODE</b>	Mode A

**ANTENNA POLARITY & TEST DISTANCE: HORIZONTAL AT 3 M**

NO.	FREQ. (MHz)	EMISSION LEVEL (dBuV/m)	LIMIT (dBuV/m)	MARGIN (dB)	ANTENNA HEIGHT (m)	TABLE ANGLE (Degree)	RAW VALUE (dBuV)	CORRECTION FACTOR (dB/m)
1	39.894	27.05 QP	40.00	-12.95	3.00 H	188	36.75	-9.70
2	100.713	33.41 QP	43.50	-10.09	2.00 H	278	47.22	-13.81
3	229.286	23.54 QP	46.00	-22.46	2.00 H	92	34.90	-11.36
4	269.590	28.63 QP	46.00	-17.37	1.00 H	85	37.08	-8.45
5	478.237	27.73 QP	46.00	-18.27	1.00 H	141	31.18	-3.45
6	600.020	32.04 QP	46.00	-13.96	2.00 H	66	32.57	-0.53

**ANTENNA POLARITY & TEST DISTANCE: VERTICAL AT 3 M**

NO.	FREQ. (MHz)	EMISSION LEVEL (dBuV/m)	LIMIT (dBuV/m)	MARGIN (dB)	ANTENNA HEIGHT (m)	TABLE ANGLE (Degree)	RAW VALUE (dBuV)	CORRECTION FACTOR (dB/m)
1	50.612	33.50 QP	40.00	-6.50	1.00 V	204	42.34	-8.84
2	101.537	30.31 QP	43.50	-13.19	1.00 V	270	44.07	-13.76
3	229.286	23.19 QP	46.00	-22.81	2.00 V	360	34.55	-11.36
4	429.155	23.22 QP	46.00	-22.78	1.00 V	81	27.64	-4.42
5	600.020	32.24 QP	46.00	-13.76	1.00 V	0	32.77	-0.53
6	687.272	29.79 QP	46.00	-16.21	1.00 V	248	28.96	0.83

**REMARKS:**

1. Emission Level(dBuV/m) = Raw Value(dBuV) + Correction Factor(dB/m)
2. Correction Factor(dB/m) = Antenna Factor(dB/m) + Cable Factor(dB) – Pre-Amplifier Factor(dB)
3. The other emission levels were very low against the limit.
4. Margin value = Emission Level – Limit value

<b>CHANNEL</b>	TX Channel 2	<b>DETECTOR FUNCTION</b>	Quasi-Peak (QP)
<b>FREQUENCY RANGE</b>	30MHz ~ 1GHz	<b>TEST MODE</b>	Mode A

ANTENNA POLARITY & TEST DISTANCE: HORIZONTAL AT 3 M								
NO.	FREQ. (MHz)	EMISSION LEVEL (dBuV/m)	LIMIT (dBuV/m)	MARGIN (dB)	ANTENNA HEIGHT (m)	TABLE ANGLE (Degree)	RAW VALUE (dBuV)	CORRECTION FACTOR (dB/m)
1	39.850	26.84 QP	40.00	-13.16	3.00 H	159	36.55	-9.71
2	101.440	33.92 QP	43.50	-9.58	3.00 H	260	47.69	-13.77
3	154.980	27.56 QP	43.50	-15.94	2.00 H	186	36.43	-8.87
4	267.210	27.44 QP	46.00	-18.56	1.00 H	89	36.01	-8.57
5	478.090	28.98 QP	46.00	-17.02	1.00 H	133	32.45	-3.47
6	599.970	31.22 QP	46.00	-14.78	2.00 H	78	31.75	-0.53
ANTENNA POLARITY & TEST DISTANCE: VERTICAL AT 3 M								
NO.	FREQ. (MHz)	EMISSION LEVEL (dBuV/m)	LIMIT (dBuV/m)	MARGIN (dB)	ANTENNA HEIGHT (m)	TABLE ANGLE (Degree)	RAW VALUE (dBuV)	CORRECTION FACTOR (dB/m)
1	51.340	33.83 QP	40.00	-6.17	1.00 V	80	42.66	-8.83
2	101.780	31.81 QP	43.50	-11.69	1.00 V	260	45.56	-13.75
3	152.030	25.32 QP	43.50	-18.18	1.00 V	157	34.34	-9.02
4	229.290	24.34 QP	46.00	-21.66	2.00 V	360	35.70	-11.36
5	600.020	30.82 QP	46.00	-15.18	2.00 V	360	31.35	-0.53
6	687.270	31.92 QP	46.00	-14.08	1.00 V	135	31.09	0.83

**REMARKS:**

1. Emission Level(dBuV/m) = Raw Value(dBuV) + Correction Factor(dB/m)
2. Correction Factor(dB/m) = Antenna Factor(dB/m) + Cable Factor(dB) – Pre-Amplifier Factor(dB)
3. The other emission levels were very low against the limit.
4. Margin value = Emission Level – Limit value

<b>CHANNEL</b>	TX Channel 3	<b>DETECTOR FUNCTION</b>	Quasi-Peak (QP)
<b>FREQUENCY RANGE</b>	30MHz ~ 1GHz	<b>TEST MODE</b>	Mode A

ANTENNA POLARITY & TEST DISTANCE: HORIZONTAL AT 3 M								
NO.	FREQ. (MHz)	EMISSION LEVEL (dBuV/m)	LIMIT (dBuV/m)	MARGIN (dB)	ANTENNA HEIGHT (m)	TABLE ANGLE (Degree)	RAW VALUE (dBuV)	CORRECTION FACTOR (dB/m)
1	39.750	25.62 QP	40.00	-14.38	3.00 H	178	35.35	-9.73
2	100.860	32.50 QP	43.50	-11.00	3.00 H	285	46.30	-13.80
3	158.480	28.56 QP	43.50	-14.94	2.00 H	360	37.36	-8.80
4	229.340	25.54 QP	46.00	-20.46	1.00 H	266	36.90	-11.36
5	280.790	26.58 QP	46.00	-19.42	1.00 H	76	34.48	-7.90
6	370.620	24.05 QP	46.00	-21.95	1.00 H	43	30.00	-5.95
7	600.020	31.55 QP	46.00	-14.45	2.00 H	91	32.08	-0.53

ANTENNA POLARITY & TEST DISTANCE: VERTICAL AT 3 M								
NO.	FREQ. (MHz)	EMISSION LEVEL (dBuV/m)	LIMIT (dBuV/m)	MARGIN (dB)	ANTENNA HEIGHT (m)	TABLE ANGLE (Degree)	RAW VALUE (dBuV)	CORRECTION FACTOR (dB/m)
1	39.770	32.90 QP	40.00	-7.10	1.00 V	249	42.62	-9.72
2	51.540	32.94 QP	40.00	-7.06	1.00 V	94	41.77	-8.83
3	100.810	29.33 QP	43.50	-14.17	1.00 V	257	43.13	-13.80
4	158.910	28.21 QP	43.50	-15.29	1.00 V	15	37.00	-8.79
5	229.240	27.39 QP	46.00	-18.61	1.00 V	23	38.75	-11.36
6	284.960	26.19 QP	46.00	-19.81	2.00 V	205	33.98	-7.79
7	599.970	31.88 QP	46.00	-14.12	1.00 V	61	32.41	-0.53

**REMARKS:**

1. Emission Level(dBuV/m) = Raw Value(dBuV) + Correction Factor(dB/m)
2. Correction Factor(dB/m) = Antenna Factor(dB/m) + Cable Factor(dB) – Pre-Amplifier Factor(dB)
3. The other emission levels were very low against the limit.
4. Margin value = Emission Level – Limit value

## 4.2 Conducted Emission Measurement

### 4.2.1 Limits of Conducted Emission Measurement

Frequency (MHz)	Conducted Limit (dBuV)	
	Quasi-peak	Average
0.15 - 0.5	66 - 56	56 - 46
0.50 - 5.0	56	46
5.0 - 30.0	60	50

Note: 1. The lower limit shall apply at the transition frequencies.

2. The limit decreases in line with the logarithm of the frequency in the range of 0.15 to 0.50MHz.

### 4.2.2 Test Instruments

Description & Manufacturer	Model No.	Serial No.	Cal. Date	Cal. Due
ROHDE & SCHWARZ TEST RECEIVER	ESCS 30	838251/021	Nov. 1, 2017	Oct. 31, 2018
ROHDE & SCHWARZ Artificial Mains Network (For EUT)	ENV216	101195	May 2, 2017	May 1, 2018
LISN With Adapter (for EUT)	AD10	C03Ada-002	May 2, 2017	May 1, 2018
EMCO L.I.S.N. (For peripherals)	3825/2	9504-2359	Jul. 25, 2017	Jul. 24, 2018
SCHWARZBECK Artificial Mains Network (For EUT)	NNLK8129	8129229	May 9, 2017	May 8, 2018
Software	Cond_V7.3.7.4	NA	NA	NA
RF cable (JYEBAO) With 10dB PAD	5D-FB	Cable-C03-01	Sep. 19, 2017	Sep. 18, 2018
LYNICS Terminator (For EMCO LISN)	0900510	E1-01-300	Jan. 18, 2017	Jan. 17, 2018
LYNICS Terminator (For EMCO LISN)	0900510	E1-01-301	Jan. 18, 2017	Jan. 17, 2018
ROHDE & SCHWARZ Artificial Mains Network (For TV EUT)	ESH3-Z5	100220	Nov. 14, 2017	Nov. 13, 2018
LISN With Adapter (for TV EUT)	100220	N/A	Nov. 14, 2017	Nov. 13, 2018

Notes: 1. The calibration interval of the above test instruments is 12 months and the calibrations are traceable to NML/ROC and NIST/USA.

2. The test was performed in Shielded Room No. 3.

3. The VCCI Site Registration No. C-10274.

#### 4.2.3 Test Procedures

- The EUT was placed 0.4 meters from the conducting wall of the shielded room with EUT being connected to the power mains through a line impedance stabilization network (LISN). Other support units were connected to the power mains through another LISN. The two LISNs provide 50 ohm/ 50uH of coupling impedance for the measuring instrument.
- Both lines of the power mains connected to the EUT were checked for maximum conducted interference.
- The frequency range from 150kHz to 30MHz was searched. Emission levels under (Limit - 20dB) was not recorded.

**NOTE:** The resolution bandwidth and video bandwidth of test receiver is 9kHz for quasi-peak detection (QP) and average detection (AV) at frequency 0.15MHz-30MHz.

#### 4.2.4 Deviation from Test Standard

No deviation.

#### 4.2.5 Test Setup

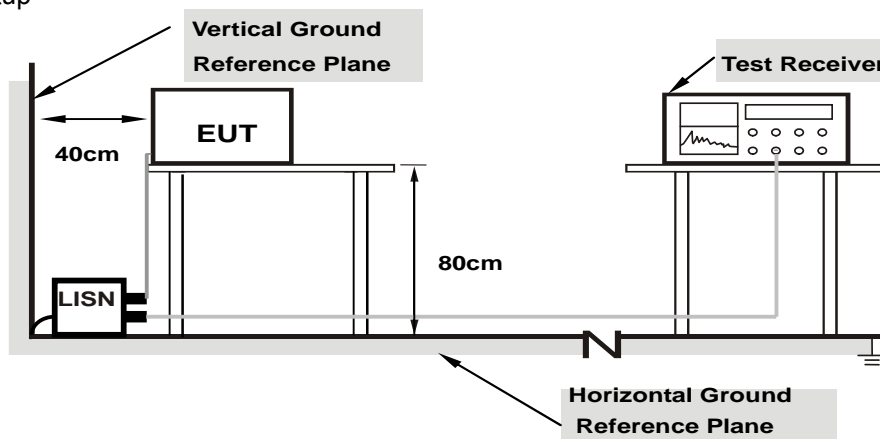

**Note: 1.Support units were connected to second LISN.**

For the actual test configuration, please refer to the attached file (Test Setup Photo).

#### 4.2.6 EUT Operating Conditions

Same as item 4.1.6.

#### 4.2.7 Test Results

<b>Frequency Range</b>	150kHz ~ 30MHz	<b>Detector Function &amp; Resolution Bandwidth</b>	Quasi-Peak (QP) / Average (AV), 9kHz
<b>Test Mode</b>	Mode A		

Phase Of Power : Line (L)										
No	Frequency (MHz)	Correction Factor (dB)	Reading Value (dBuV)		Emission Level (dBuV)		Limit (dBuV)		Margin (dB)	
			Q.P.	AV.	Q.P.	AV.	Q.P.	AV.	Q.P.	AV.
1	0.35703	9.58	30.63	24.32	40.21	33.90	58.80	48.80	-18.59	-14.90
2	1.16797	9.62	22.56	17.65	32.18	27.27	56.00	46.00	-23.82	-18.73
3	4.33984	9.73	25.30	15.74	35.03	25.47	56.00	46.00	-20.97	-20.53
4	7.35156	9.79	15.58	9.59	25.37	19.38	60.00	50.00	-34.63	-30.62
5	12.19141	9.85	20.13	12.25	29.98	22.10	60.00	50.00	-30.02	-27.90
6	15.88672	9.87	21.67	20.39	31.54	30.26	60.00	50.00	-28.46	-19.74

**Remarks:**

1. Q.P. and AV. are abbreviations of quasi-peak and average individually.
2. The emission levels of other frequencies were very low against the limit.
3. Margin value = Emission level – Limit value
4. Correction factor = Insertion loss + Cable loss
5. Emission Level = Correction Factor + Reading Value

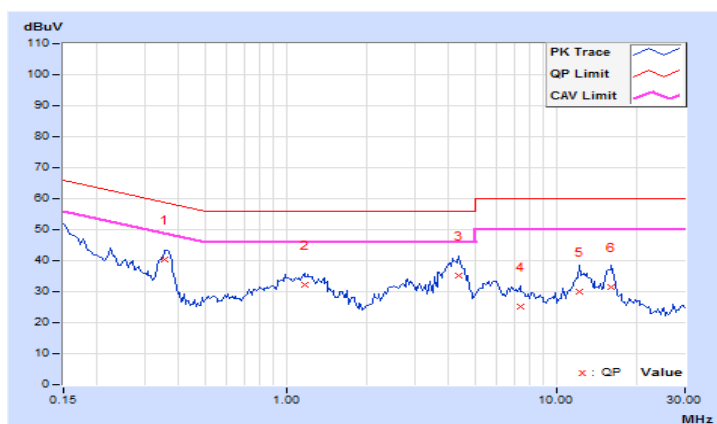

<b>Frequency Range</b>	150kHz ~ 30MHz	<b>Detector Function &amp; Resolution Bandwidth</b>	Quasi-Peak (QP) / Average (AV), 9kHz
<b>Test Mode</b>	Mode A		

Phase Of Power : Neutral (N)										
No	Frequency (MHz)	Correction Factor (dB)	Reading Value (dBuV)		Emission Level (dBuV)		Limit (dBuV)		Margin (dB)	
			Q.P.	AV.	Q.P.	AV.	Q.P.	AV.	Q.P.	AV.
1	0.34922	9.74	29.52	21.45	39.26	31.19	58.98	48.98	-19.72	-17.79
2	1.17188	9.79	24.33	18.26	34.12	28.05	56.00	46.00	-21.88	-17.95
3	2.76563	9.85	21.35	16.05	31.20	25.90	56.00	46.00	-24.80	-20.10
4	4.18359	9.89	27.02	18.87	36.91	28.76	56.00	46.00	-19.09	-17.24
5	10.55726	10.01	14.26	8.57	24.27	18.58	60.00	50.00	-35.73	-31.42
6	13.76563	10.05	28.31	25.06	38.36	35.11	60.00	50.00	-21.64	-14.89

**Remarks:**

1. Q.P. and AV. are abbreviations of quasi-peak and average individually.
2. The emission levels of other frequencies were very low against the limit.
3. Margin value = Emission level – Limit value
4. Correction factor = Insertion loss + Cable loss
5. Emission Level = Correction Factor + Reading Value

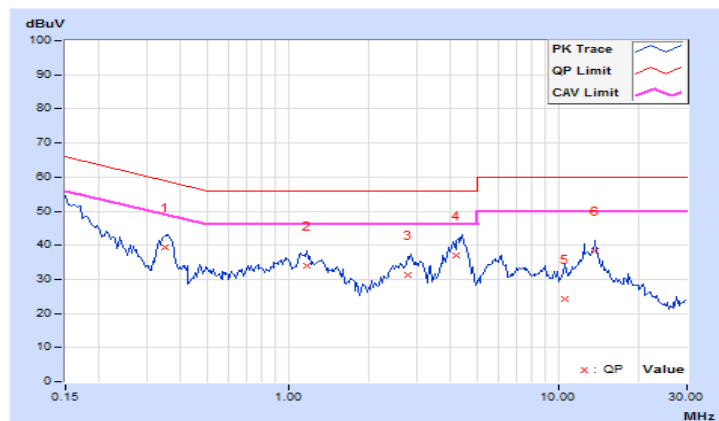



<b>Frequency Range</b>	150kHz ~ 30MHz	<b>Detector Function &amp; Resolution Bandwidth</b>	Quasi-Peak (QP) / Average (AV), 9kHz
<b>Test Mode</b>	Mode B		

Phase Of Power : Line (L)										
No	Frequency (MHz)	Correction Factor (dB)	Reading Value (dBuV)		Emission Level (dBuV)		Limit (dBuV)		Margin (dB)	
			Q.P.	AV.	Q.P.	AV.	Q.P.	AV.	Q.P.	AV.
1	0.53281	9.59	32.96	20.78	42.55	30.37	56.00	46.00	-13.45	-15.63
<b>2</b>	<b>0.87266</b>	<b>9.60</b>	<b>34.55</b>	<b>20.82</b>	<b>44.15</b>	<b>30.42</b>	<b>56.00</b>	<b>46.00</b>	<b>-11.85</b>	<b>-15.58</b>
3	1.39978	9.63	34.14	21.29	43.77	30.92	56.00	46.00	-12.23	-15.08
4	3.33594	9.70	28.24	17.12	37.94	26.82	56.00	46.00	-18.06	-19.18
5	5.75781	9.76	25.70	14.73	35.46	24.49	60.00	50.00	-24.54	-25.51
6	10.44922	9.84	23.00	10.55	32.84	20.39	60.00	50.00	-27.16	-29.61

**Remarks:**

1. Q.P. and AV. are abbreviations of quasi-peak and average individually.
2. The emission levels of other frequencies were very low against the limit.
3. Margin value = Emission level – Limit value
4. Correction factor = Insertion loss + Cable loss
5. Emission Level = Correction Factor + Reading Value

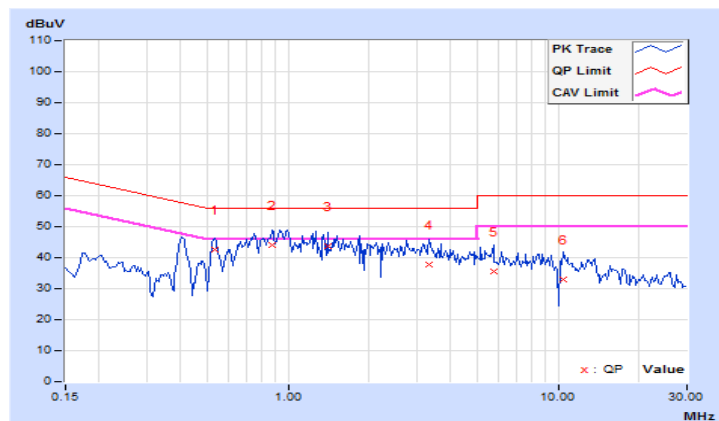

<b>Frequency Range</b>	150kHz ~ 30MHz	<b>Detector Function &amp; Resolution Bandwidth</b>	Quasi-Peak (QP) / Average (AV), 9kHz
<b>Test Mode</b>	Mode B		

Phase Of Power : Neutral (N)										
No	Frequency (MHz)	Correction Factor (dB)	Reading Value (dBuV)		Emission Level (dBuV)		Limit (dBuV)		Margin (dB)	
			Q.P.	AV.	Q.P.	AV.	Q.P.	AV.	Q.P.	AV.
1	0.17734	9.74	37.33	24.79	47.07	34.53	64.61	54.61	-17.54	-20.08
2	0.48984	9.75	29.84	17.46	39.59	27.21	56.17	46.17	-16.58	-18.96
3	0.98984	9.78	31.15	18.25	40.93	28.03	56.00	46.00	-15.07	-17.97
4	3.55469	9.88	26.83	18.12	36.71	28.00	56.00	46.00	-19.29	-18.00
5	10.57813	10.01	23.19	13.65	33.20	23.66	60.00	50.00	-26.80	-26.34
6	19.10156	10.12	20.81	9.47	30.93	19.59	60.00	50.00	-29.07	-30.41

**Remarks:**

1. Q.P. and AV. are abbreviations of quasi-peak and average individually.
2. The emission levels of other frequencies were very low against the limit.
3. Margin value = Emission level – Limit value
4. Correction factor = Insertion loss + Cable loss
5. Emission Level = Correction Factor + Reading Value

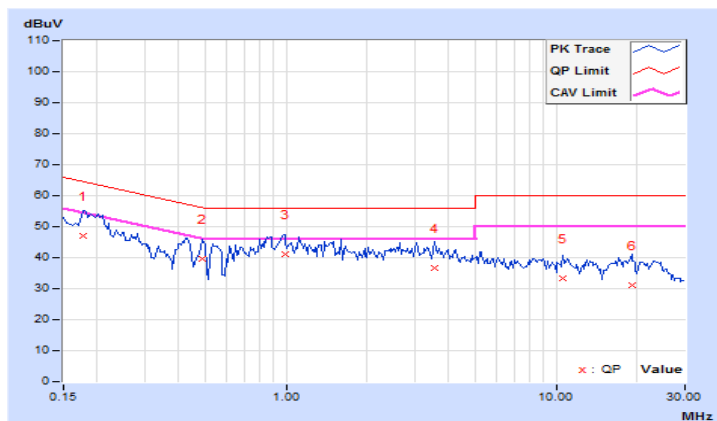

## 4.3 Channel Bandwidth

### 4.3.1 Test Setup

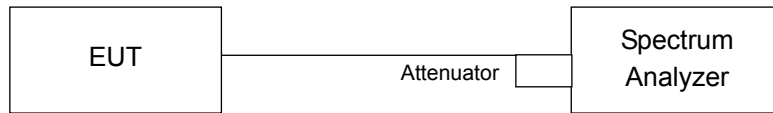

### 4.3.2 Test Instruments

Refer to section 4.1.2 to get information of above instrument.

### 4.3.3 Test Procedure

- a. Check the calibration of the measuring instrument using either an internal calibrator or a known signal from an external generator.
- b. Turn on the EUT and connect it to measurement instrument. Then set it to any one convenient frequency within its operating range. Set a reference level on the measuring instrument equal to the highest peak value.
- c. Measure the frequency difference of two frequencies that were attenuated 20dB from the reference level. Record the frequency difference as the emission bandwidth.
- d. Repeat above procedures until all frequencies measured were complete.

### 4.3.4 Deviation from Test Standard

No deviation.

### 4.3.5 EUT Operating Condition

The software provided by client enabled the EUT to transmit and receive data at lowest, middle and highest channel frequencies individually.

#### 4.3.6 Test Results

Channel	Frequency (kHz)	20dB BANDWIDTH (MHz)
1	139	0.137
2	150	0.148
3	114	0.112

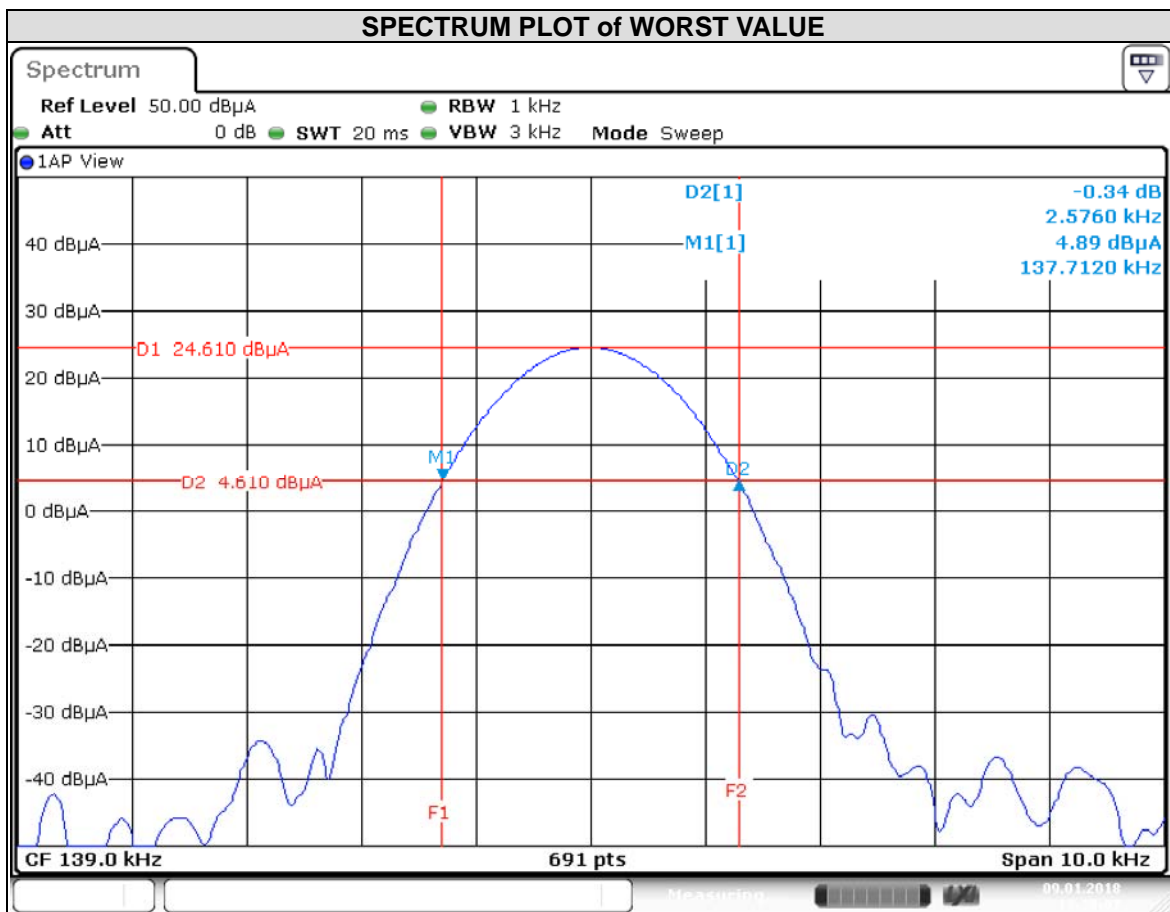

## 4.4 Occupied Bandwidth Measurement

### 4.4.1 Test SetUp

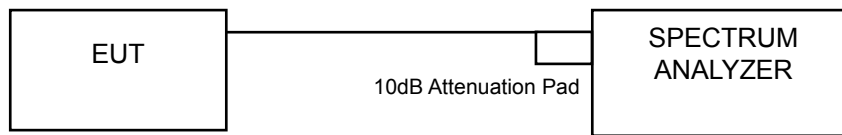

### 4.4.2 Test Instruments

Refer to section 4.1.2 to get information of above instrument.

### 4.4.3 Test Procedure

The transmitter output was connected to the spectrum analyzer through an attenuator. The bandwidth of the fundamental frequency was measured by spectrum analyzer with resolution bandwidth in the range of 1% to 5% of the anticipated emission bandwidth, and a video bandwidth at least 3x the resolution bandwidth. The width of a frequency band such that, below the lower and above the upper frequency limits, the mean powers emitted are each equal to a specified percentage 0.5 %of the total mean power of a given emission.

### 4.4.4 Deviation from Test Standard

No deviation.

### 4.4.5 EUT Operating Conditions

The software provided by client to enable the EUT under transmission condition continuously.

#### 4.4.6 Test Results

Channel	Frequency (kHz)	Occupied Bandwidth (kHz)
1	139	2.228
2	150	2.228
3	114	2.228

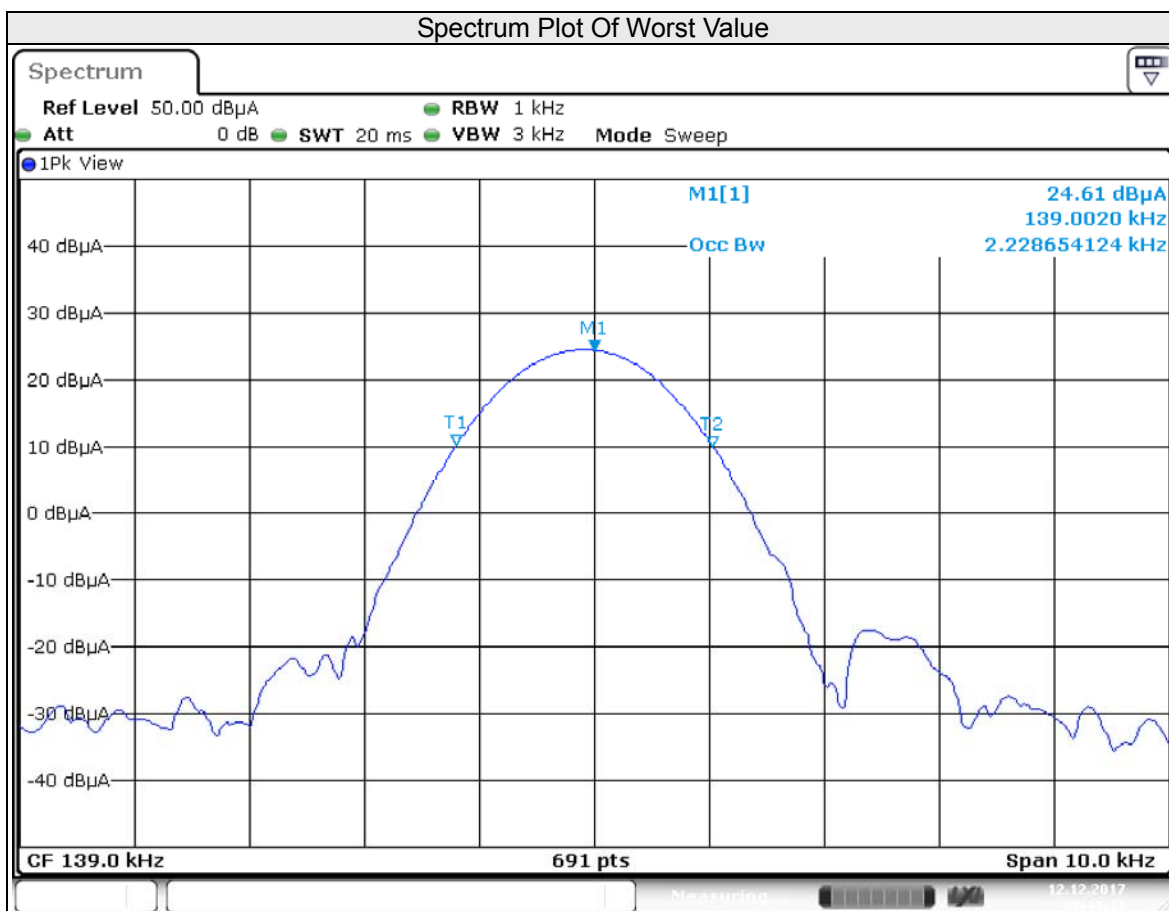

## 5 Pictures of Test Arrangements

Please refer to the attached file (Test Setup Photo).

## Appendix – Information on the Testing Laboratories

We, Bureau Veritas Consumer Products Services (H.K.) Ltd., Taoyuan Branch, were founded in 1988 to provide our best service in EMC, Radio, Telecom and Safety consultation. Our laboratories are accredited and approved according to ISO/IEC 17025.

If you have any comments, please feel free to contact us at the following:

**Linko EMC/RF Lab**

Tel: 886-2-26052180

Fax: 886-2-26051924

**Hsin Chu EMC/RF/Telecom Lab**

Tel: 886-3-6668565

Fax: 886-3-6668323

**Hwa Ya EMC/RF/Safety Lab**

Tel: 886-3-3183232

Fax: 886-3-3270892

**Email:** [service.adt@tw.bureauveritas.com](mailto:service.adt@tw.bureauveritas.com)

**Web Site:** [www.bureauveritas-adt.com](http://www.bureauveritas-adt.com)

The address and road map of all our labs can be found in our web site also.

--- END ---