



Prüfbericht-Nr.: <i>Test Report No.:</i>	50310420 001	Auftrags-Nr.: <i>Order No.:</i>	238111664	Seite 1 von 49 <i>Page 1 of 49</i>
Kunden-Referenz-Nr.: <i>Client Reference No.:</i>	N/A	Auftragsdatum: <i>Order date:</i>	30-Oct-2019	
Auftraggeber: <i>Client:</i>	Corsair Memory Inc.. 47100 Bayside Parkway 94538 Fremont, CA United States			
Prüfgegenstand: <i>Test item:</i>	Key Light Air			
Bezeichnung / Typ-Nr.: <i>Identification / Type No.:</i>	20LAB9901			
Auftrags-Inhalt: <i>Order content:</i>	FCC Part 15C / ISCED RSS-247 Test report(Wi-Fi 2.4GHz)			
Prüfgrundlage: <i>Test specification:</i>	FCC 47CFR Part 15: Subpart C Section 15.247(DTS) ISCED RSS-247 ISSUE 2 FEB 2017			
Wareneingangsdatum: <i>Date of receipt:</i>	30-Oct-2019			
Prüfmuster-Nr.: <i>Test sample No.:</i>	A0001016719-001 A0001016719-002			
Prüfzeitraum: <i>Testing period:</i>	31-Oct-2019 - 20-Nov-2019			
Ort der Prüfung: <i>Place of testing:</i>	EMC/RF Laboratory Taipei			
Prüflaboratorium: <i>Testing laboratory:</i>	TUV Rheinland Taiwan Ltd.			
Prüfergebnis*: <i>Test result*:</i>	Pass			
Report date / tested by:		kontrolliert von / reviewed by:		
				
2020-03-12 Mars Y.J. Lin / Project Engineer		2020-03-12 Ryan W.T. Chen / Project Manager		
Datum <i>Date</i>	Name / Stellung <i>Name / Position</i>	Unterschrift <i>Signature</i>	Datum <i>Date</i>	Name / Stellung <i>Name / Position</i>
				Unterschrift <i>Signature</i>
Sonstiges / Other:				
Zustand des Prüfgegenstandes bei Anlieferung: <i>Condition of the test item at delivery:</i>		Prüfmuster vollständig und unbeschädigt <i>Test item complete and undamaged</i>		
* Legende: 1 = sehr gut 2 = gut 3 = befriedigend 4 = ausreichend 5 = mangelhaft P(ass) = entspricht o.g. Prüfgrundlage(n) F(ail) = entspricht nicht o.g. Prüfgrundlage(n) N/A = nicht anwendbar N/T = nicht getestet				
Legend: 1 = very good 2 = good 3 = satisfactory 4 = sufficient 5 = poor P(ass) = passed a.m. test specification(s) F(ail) = failed a.m. test specification(s) N/A = not applicable N/T = not tested				
Dieser Prüfbericht bezieht sich nur auf das o.g. Prüfmuster und darf ohne Genehmigung der Prüfstelle nicht auszugsweise vervielfältigt werden. Dieser Bericht berechtigt nicht zur Verwendung eines Prüfzeichens. <i>This test report only relates to the a. m. test sample. Without permission of the test center this test report is not permitted to be duplicated in extracts. This test report does not entitle to carry any test mark.</i>				

TEST SUMMARY

5.1.1 ANTENNA REQUIREMENT

RESULT: *Passed*

5.1.2 PEAK OUTPUT POWER

RESULT: *Passed*

5.1.3 6dB BANDWIDTH AND 99% BANDWIDTH

RESULT: *Passed*

5.1.4 POWER DENSITY

RESULT: *Passed*

5.1.5 CONDUCTED SPURIOUS EMISSIONS AND FREQUENCY BAND EDGE MEASURED IN 100kHz BANDWIDTH

RESULT: *Passed*

5.1.6 SPURIOUS EMISSION

RESULT: *Passed*

5.2.1 MAINS CONDUCTED EMISSIONS

RESULT: *Passed*

6.1.1 ELECTROMAGNETIC FIELDS

RESULT: *Passed*

Contents

1.	GENERAL REMARKS	5
1.1	COMPLEMENTARY MATERIALS	5
2.	TEST SITES.....	6
2.1	TEST LABORATORY	6
2.2	TEST FACILITY	6
2.3	LIST OF TEST AND MEASUREMENT INSTRUMENTS	7
2.4	TRACEABILITY	8
2.5	CALIBRATION.....	8
2.6	MEASUREMENT UNCERTAINTY	8
3.	GENERAL PRODUCT INFORMATION	9
3.1	PRODUCT FUNCTION AND INTENDED USE.....	9
3.2	SYSTEM DETAILS AND RATINGS	9
3.3	INDEPENDENT OPERATION MODES.....	10
3.4	NOISE GENERATING AND NOISE SUPPRESSING PARTS.....	10
3.5	SUBMITTED DOCUMENTS	10
4.	TEST SET-UP AND OPERATION MODES	11
4.1	PRINCIPLE OF CONFIGURATION SELECTION.....	11
4.2	TEST OPERATION AND TEST SOFTWARE	12
4.3	SPECIAL ACCESSORIES AND AUXILIARY EQUIPMENT	13
4.4	COUNTERMEASURES TO ACHIEVE EMC COMPLIANCE	13
4.5	TEST SETUP DIAGRAM.....	13
5.	TEST RESULTS	15
5.1	TRANSMITTER REQUIREMENT & TEST SUITES	15
5.1.1	<i>Antenna Requirement</i>	<i>15</i>
5.1.2	<i>Peak Output Power.....</i>	<i>16</i>
5.1.3	<i>6dB Bandwidth and 99% Bandwidth.....</i>	<i>18</i>
5.1.4	<i>Power Density.....</i>	<i>31</i>
5.1.5	<i>Conducted spurious emissions and Frequency Band Edge measured in 100kHz Bandwidth</i>	<i>37</i>
5.1.6	<i>Spurious Emission.....</i>	<i>46</i>
5.2	MAINS EMISSIONS.....	47
5.2.1	<i>Mains Conducted Emissions</i>	<i>47</i>
6.	SAFETY HUMAN EXPOSURE.....	48

Prüfbericht- Nr.: 50310420 001
*Test Report No.***Seite 4 von 49**
Page 4 of 49

6.1	RADIO FREQUENCY EXPOSURE COMPLIANCE	48
6.1.1	<i>Electromagnetic Fields</i>	<i>48</i>
7.	LIST OF TABLES.....	49

1. General Remarks

1.1 Complementary Materials

The following attachments are integral parts of this test report:

Appendix P: Photo Documentation internal view
(File Name: 50310420 001 001 APPENDIX P)

Appendix D: Test Result of Radiated Emissions
(File Name: 50310420 001 001 APPENDIX D)

Appendix S: Photographs of the Test Set-Up
(File Name: 50310420 001 001 APPENDIX S)

Test Specification

The following standards were applied.

Table 1: Applied Standard and Test Levels

Radio
FCC CFR47 Part 15: Subpart C Section 15.247
FCC 47CFR Part 2: Subpart J Section 2.1091
ANSI C63.10:2013
KDB558074 D01 DTS Meas Guidance v05
RSS-247 Issue 2 Feb 2017
RSS-102 Issue 5 Mar 2015
RSS-Gen Issue 5 Apr 2018

2. Test Sites

2.1 Test Laboratory

TUV Rheinland Taiwan Ltd.

11F. No.758, Sec. 4, Bade Rd., Songshan Dist.
Taipei City 105
Taiwan (R.O.C.)

2.2 Test Facility

TUV Rheinland Taiwan Ltd.

AC Mains Conduction:
11F. No.758, Sec. 4, Bade Rd., Songshan Dist.
Taipei City 105
Taiwan (R.O.C.)
FCC Registration No.: 180491
IC Canada Registration No.: 9465A

Conducted Test / Radiated Test:
No. 458-18, Sec 2, Fenliao., Linkou Dist.
New Taipei City 244
Taiwan (R.O.C.)
FCC Registration No.: 226631
IC Canada Registration No.: 25563

TAF Accredited NCC Test Lab. No.:3567
TAF ISO17025 Certification effective period: 6th-May-2019 to 05th-May-2022



Testing Laboratory
3567

2.3 List of Test and Measurement Instruments

Table 2: List of Test and Measurement Equipment

Equipment	Manufacturer	Model No.	Serial No.	Cal. Date	Cal. Due Date
EMI Test Receiver	R&S	ESR7	102108	2019/2/06	2020/2/05
Spectrum Analyzer	R&S	FSV40	101508	2019/2/05	2020/2/04
Pre-Amplifier	Agilent	8447D	2944A10772	2019/2/22	2020/2/21
Pre-Amplifier	EMCI	EMC051845SE	980633	2019/2/25	2020/2/24
Pre-Amplifier	EMCI	EMC184045SE	980657	2019/2/23	2020/2/22
Bilog Antenna	SCHWARZBECK	VULB-9168	00951	2019/1/14	2020/1/13
Horn Antenna	ETS-Lindgren	3117	00218930	2018/12/27	2019/12/26
Horn Antenna	SCHWARZBECK	BBHA 9170	00887	2019/4/12	2020/4/11
Loop Antenna	EMCI	LPA600	287	2018/12/20	2019/12/19
Test Software	Audix	e3	Ver. 9	N/A	N/A
Test Cable	HUBER+SUHNER	SUCOFLEX 104EA_9k~18G	800056/4EA	2019/4/18	2020/4/17
Test Cable	HUBER+SUHNER	SUCOFLEX 104_9k~18G	804680/4	2019/4/18	2020/4/17
Test Cable	HUBER+SUHNER	SUCOFLEX 104_9k~18G	MY37202/4	2019/4/18	2020/4/17
Test Cable	HUBER+SUHNER	SUCOFLEX 102EA_1G~40G	800898/2EA	2019/4/18	2020/4/17
Test Cable	HUBER+SUHNER	SUCOFLEX 102EA_1G~40G	800901/2EA	2019/4/18	2020/4/17
Test Cable	HUBER+SUHNER	SUCOFLEX 102EA_1G~40G	801027/2EA	2019/4/18	2020/4/17
Power Meter	Anritsu	ML2495A	1901008	2019/4/29	2020/4/28
Spectrum Analyzer	R&S	FSV40	101513	2019/2/8	2020/2/8
EMI Test Receiver	Rohde & Schwarz	ESCI 7	100797	2019/01/16	2020/01/16
Two-Line V-Network (for EUT)	Rohde & Schwarz	ENV216	101243	2019/06/23	2020/06/23
Two-Line V-Network	Rohde & Schwarz	ENV216	101262	2019/07/16	2020/07/16
Telecom ISN 4 Line	Fischer Custom Communications	FFCC-TLISN- T4-02-09	101168	2019/01/02	2020/01/02
Impedance Stabilization Network	TESEQ	ISN T800	51949	2019/02/20	2020/02/20
Pulse Limiter	Rohde & Schwarz	ESH3-Z2	0357.8810.54- 102102-HN	2019/07/25	2020/07/25

2.4 Traceability

All measurement equipment calibrations are traceable to NML(Taiwan)/NIST(USA) or where calibration is performed outside Taiwan, to equivalent nationally recognized standards organizations.

2.5 Calibration

Equipment requiring calibration is calibrated periodically by the manufacturer or according to manufacturer's specifications. Additionally all equipment is verified for proper performance on a regular basis using in house standards or comparisons.

2.6 Measurement Uncertainty

The estimated combined standard uncertainty for radiated emissions and conducted emissions measurements are $\pm 3\text{dB}$.

Table 3: Emission Measurement Uncertainty

Parameter	Uncertainty
Radio Frequency	± 0.1 ppm
RF power/RF Exposure(MPE), conducted	± 1.5 dB
RF power density, conducted	± 3 dB
spurious emissions, conducted	± 3 dB
all emissions, radiated	± 6 dB
Temperature	± 1 °C
Humidity	± 5 %
DC and low frequency voltages	± 3 %

3. General Product Information

3.1 Product Function and Intended Use

The EUT is a Key Light Air. It contains a WiFi compatible module enabling the user to communicate data through a Wireless interface.
 For details refer to the User Guide, Data Sheet and Circuit Diagram.

3.2 System Details and Ratings

Table 4: Basic Information of EUT

Item	EUT information
Kind of Equipment	Key Light Air
Type Designation	20LAB9901
FCC ID	2AAFM-20LAB9901
IC ID	10954A-20LAB9901

Table 5: Technical Specification of EUT

Technical Specification	Value
Operating Frequencies	2412~2462 MHz
Channel Spacing	5 MHz
Channel number	802.11b/g/n20(only): 11 (2412 MHz ~ 2462 MHz)
Operation Voltage	120Vac
Modulation	802.11b: DSSS 802.11g/n: OFDM with BPSK, QPSK, QAM
Antenna gain	-1dBi

3.3 Independent Operation Modes

Basic operation modes are:

- A. Transmitting
 - 1. Low channel
 - 2. Middle channel
 - 3. High channel
- B. Receiving
- C. Normal Link
- D. Off

3.4 Noise Generating and Noise Suppressing Parts

Refer to the Circuit Diagram.

3.5 Submitted Documents

- Block Diagram
- PCB Layout
- Photo Document
- Technical Description
- Circuit Diagram
- Instruction Manual
- Rating Label

4. Test Set-up and Operation Modes

4.1 Principle of Configuration Selection

The test modes were adapted accordingly in reference to the instructions for use.

During testing, Channel and Power Controlling Software provided by the customer was used to control the operating channel as well as the output power level. The RF output power selection is for the setting of RF output power expected by the customer and is going to be fixed on the firmware of the final end product.

Table 6: Table for Parameters of Test Software Setting

Mode	Channel Frequency		
	2412 MHz	2437 MHz	2462 MHz
802.11b	32	38	48
802.11g	51	63	56
802.11n20	55	63	55

4.2 Test Operation and Test Software

Setup for testing: Test samples are provided with a USB interface which makes it possible to control them through a test software installed on a notebook computer.

This software UI_mptool.exe was running on the laptop computer connected to the EUT. It was used to enable the operation modes listed in section 3.3 as appropriate.

The samples were used as follows:

Conducted: A001016719-002

Radiation: A001016719-001

Full test was applied on all test modes, but only worst case was shown

IEEE 802.11b mode:

Channel Low (2412MHz), Channel Mid (2437MHz) and Channel High (2462MHz) with 1Mbps data rate were chosen for full testing.

IEEE 802.11g mode:

Channel Low (2412MHz), Channel Mid (2437MHz) and Channel High (2462MHz) with 6Mbps data rate were chosen for full testing.

IEEE 802.11n HT 20 mode:

Channel Low (2412MHz), Channel Mid (2437MHz) and Channel High (2462MHz) with 6.5Mbps data rate were chosen for full testing.

4.3 Special Accessories and Auxiliary Equipment

The product has been tested together with the following additional accessories:

Description	Manufacturer	Model No.	Serial No.
Notebook(EMC-06)	Lenovo	TP00048A	PB-0F8B2

4.4 Countermeasures to achieve EMC Compliance

The test sample which has been tested contained the noise suppression parts as described in the Constructional Data Form or the Technical Construction File. No additional measures were employed to achieve compliance.

4.5 Test Setup Diagram

Diagram of Measurement Configuration for Radiation Test

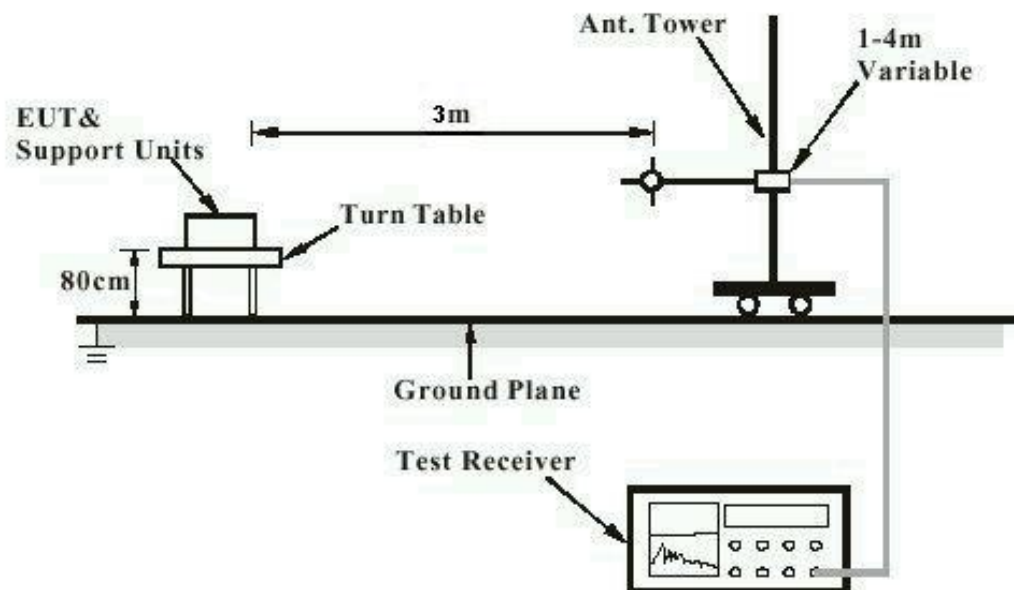

Note: Measurements above 1 GHz are done with a table height of 1.5m.

Diagram of Measurement Equipment Configuration for Mains Conduction Measurement (if applicable)

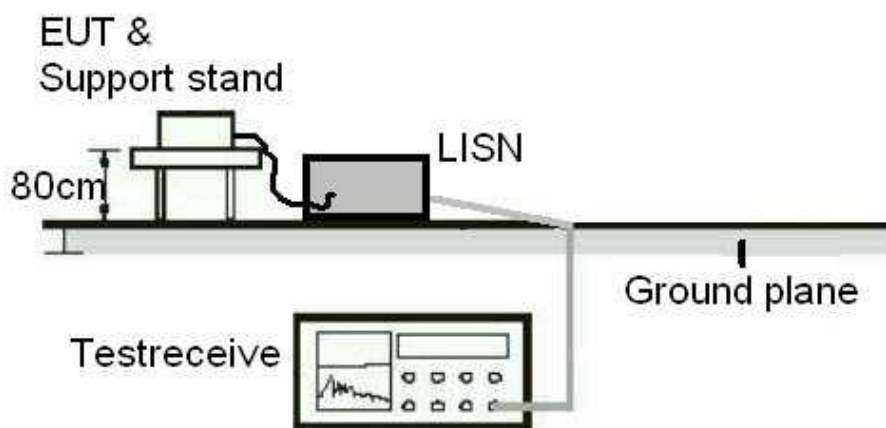
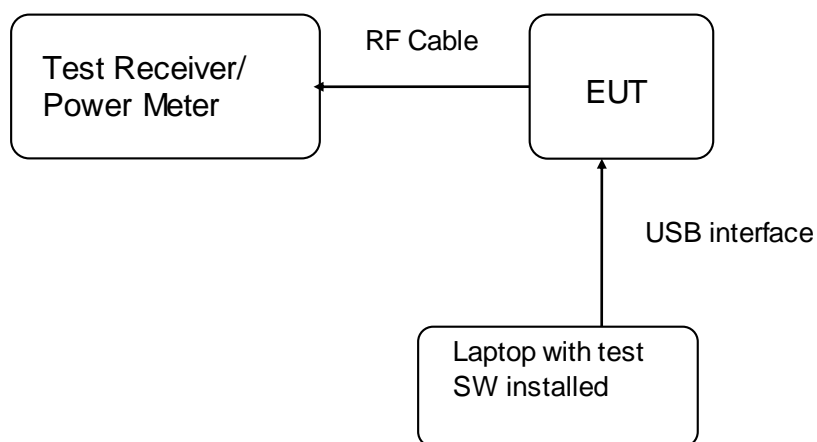

Diagram of Measurement Equipment Configuration for Conducted Transmitter Measurement



5. Test Results

5.1 Transmitter Requirement & Test Suites

5.1.1 Antenna Requirement

RESULT: **Passed**

Test standard : FCC Part 15.247(b)(4), Part 15.203 and RSS-Gen 6.8

Limit : the use of antennas with directional gains that do not exceed 6 dBi

According to the manufacturer declaration, the EUT has an antenna with a directional gain of -1dBi. The antenna is a Chip Antenna soldered to the PCB with no possibility of replacement with a non-approved antenna by the end-user. Therefore, the EUT is considered to comply with this provision.

Refer to EUT photo for details.

5.1.2 Peak Output Power

RESULT:
Passed

Test standard : FCC Part 15.247(b)(3), RSS-247 5.4(4)
 Basic standard : ANSI C63.10:2013, KDB558074
 Limit : 1 Watt
 Kind of test site : Shielded room

Test setup

Test Channel : Low/ Middle/ High
 Operation Mode : A
 Test Lab : Linkou

 Ambient temperature : 22-26 °C
 Relative humidity : 50-65 %
 Atmospheric pressure : 100-103 kPa

Table 7: Test result of Peak Output Power (802.11b)

Channel	Channel Frequency (MHz)	Output Power		Average power	Limit
		(dBm)	(W)	(dBm)	(W)
Low Channel	2412	16.31	0.04276	13.51	1
Middle Channel	2437	19.18	0.08279	16.43	1
High Channel	2462	22.43	0.17498	19.81	1

Table 8: Test result of Peak Output Power (802.11g)

Channel	Channel Frequency (MHz)	Output Power		Average power	Limit
		(dBm)	(W)	(dBm)	(W)
Low Channel	2412	24.66	0.29242	16.48	1
Middle Channel	2437	24.95	0.31261	20.71	1
High Channel	2462	24.9	0.30903	18.29	1

Table 9: Test result of Peak Output Power (802.11n HT20)

Channel	Channel Frequency (MHz)	Output Power		Average power	Limit
		(dBm)	(W)	(dBm)	(W)
Low Channel	2412	24.77	0.29992	17.95	1
Middle Channel	2437	24.98	0.31477	20.71	1
High Channel	2462	24.77	0.29992	17.86	1

Max Peak Power: 314.77 mW
Max Average Power: 117.76 mW

5.1.3 6dB Bandwidth and 99% Bandwidth

RESULT:**Passed**

Test standard : FCC Part 15.247(a)(2), RSS-247 5.2(1)
RSS-Gen (Issue 4)
Basic standard : ANSI C63.10:2013, KDB558074
Kind of test site : Shielded room

Test setup

Test Channel : Low/ Middle/ High
Operation Mode : A
Test Lab : Linkou

Ambient temperature : 22-26°C
Relative humidity : 50-65%
Atmospheric pressure : 100-103 kPa

Table 10: Test result of 6dB Bandwidth (802.11b)

Channel	Channel Frequency (MHz)	6dB Bandwidth (MHz)	Limit (MHz)	Result
Low Channel	2412	9.05	0.5	Pass
Mid Channel	2437	9.05	0.5	Pass
High Channel	2462	9.02	0.5	Pass

Table 11: Test result of 6dB Bandwidth (802.11g)

Channel	Channel Frequency (MHz)	6dB Bandwidth (MHz)	Limit (MHz)	Result
Low Channel	2412	16.54	0.5	Pass
Mid Channel	2437	16.45	0.5	Pass
High Channel	2462	16.51	0.5	Pass

Table 12: Test result of 6dB Bandwidth (802.11n HT20)

Channel	Channel Frequency (MHz)	6dB Bandwidth (MHz)	Limit (MHz)	Result
Low Channel	2412	17.74	0.5	Pass
Mid Channel	2437	17.8	0.5	Pass
High Channel	2462	17.71	0.5	Pass

Table 13: Test result of 99% Bandwidth (802.11b)

Channel	Channel Frequency (MHz)	99% Bandwidth (MHz)
Low Channel	2412	13.59
Mid Channel	2437	13.43
High Channel	2462	13.55

Table 14: Test result of 99% Bandwidth (802.11g)

Channel	Channel Frequency (MHz)	99% Bandwidth (MHz)
Low Channel	2412	17.02
Mid Channel	2437	23.53
High Channel	2462	17.26

Table 15: Test result of 99% Bandwidth (802.11n HT20)

Channel	Channel Frequency (MHz)	99% Bandwidth (MHz)
Low Channel	2412	18.30
Mid Channel	2437	25.97
High Channel	2462	18.14

Test Plot of 6dB Bandwidth (802.11b)

Low Channel

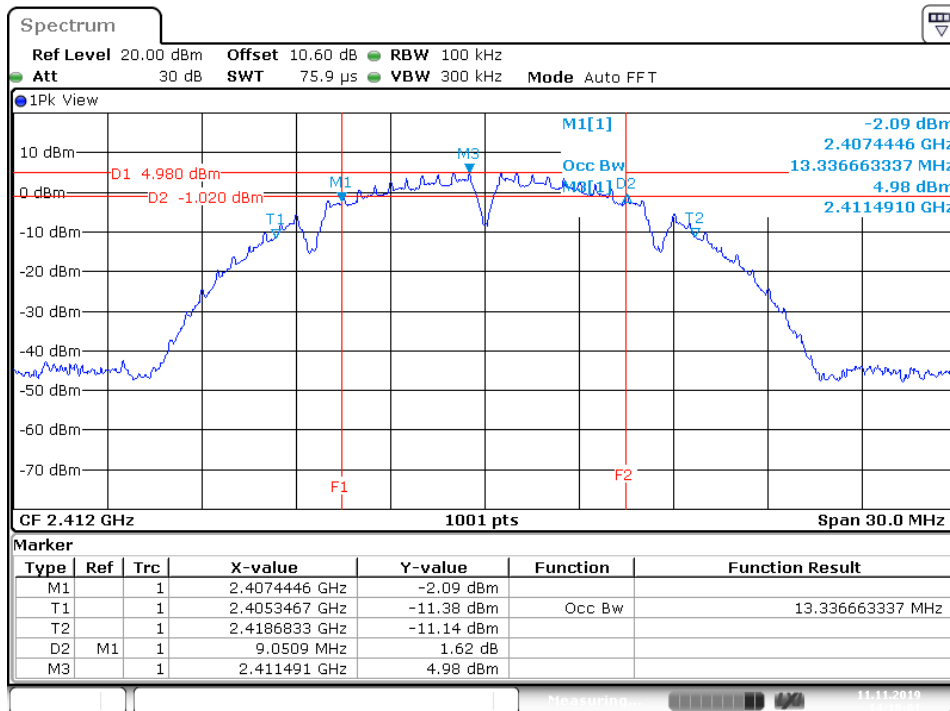

Date: 11.NOV.2019 14:18:01

Middle Channel

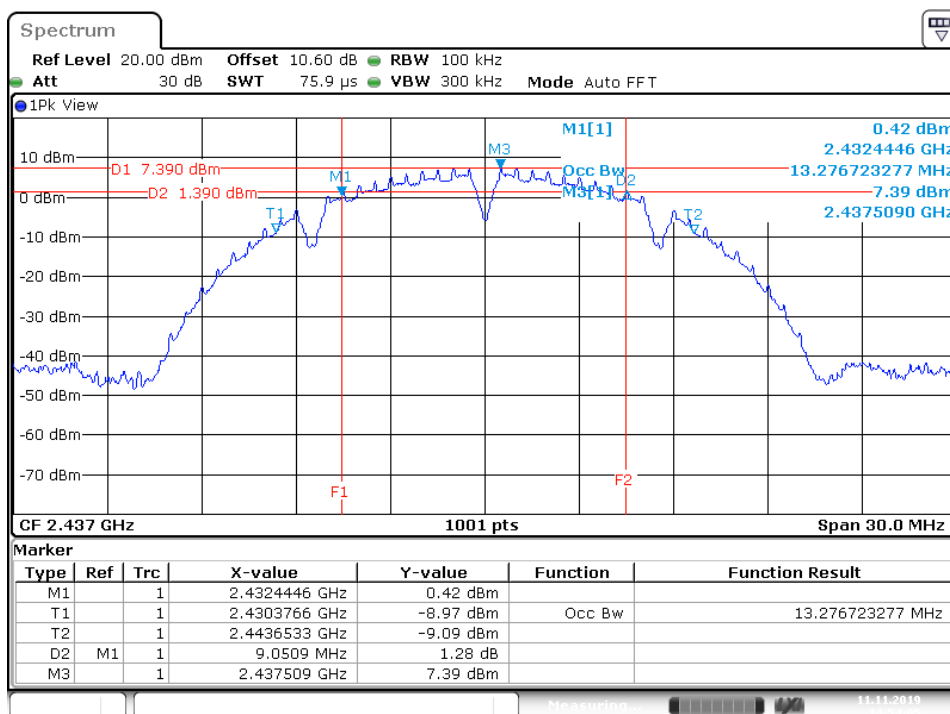

Date: 11.NOV.2019 14:54:05

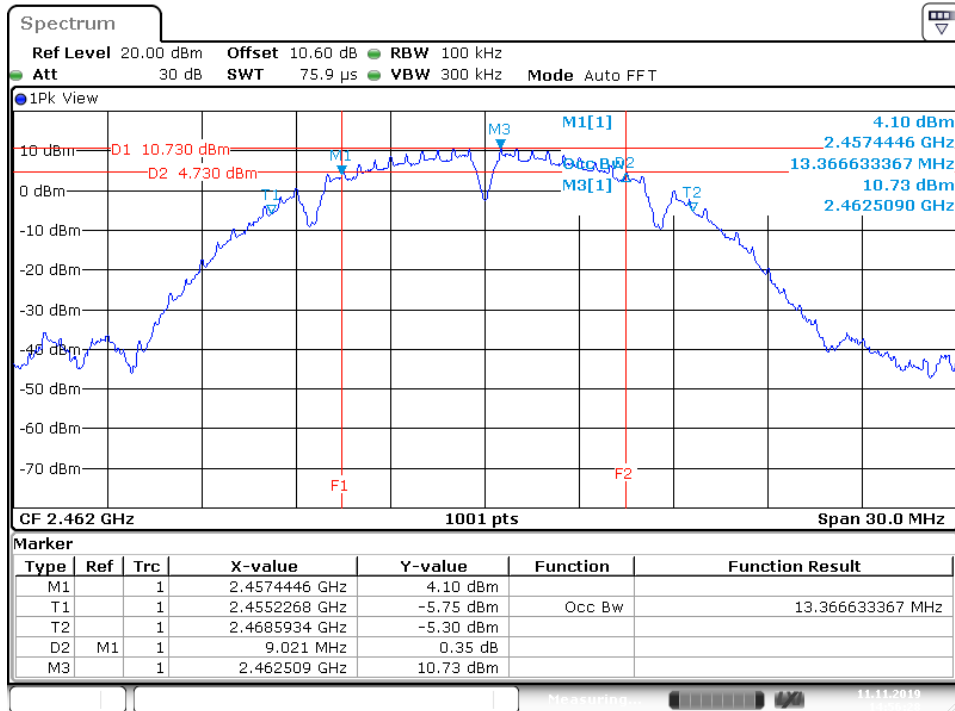
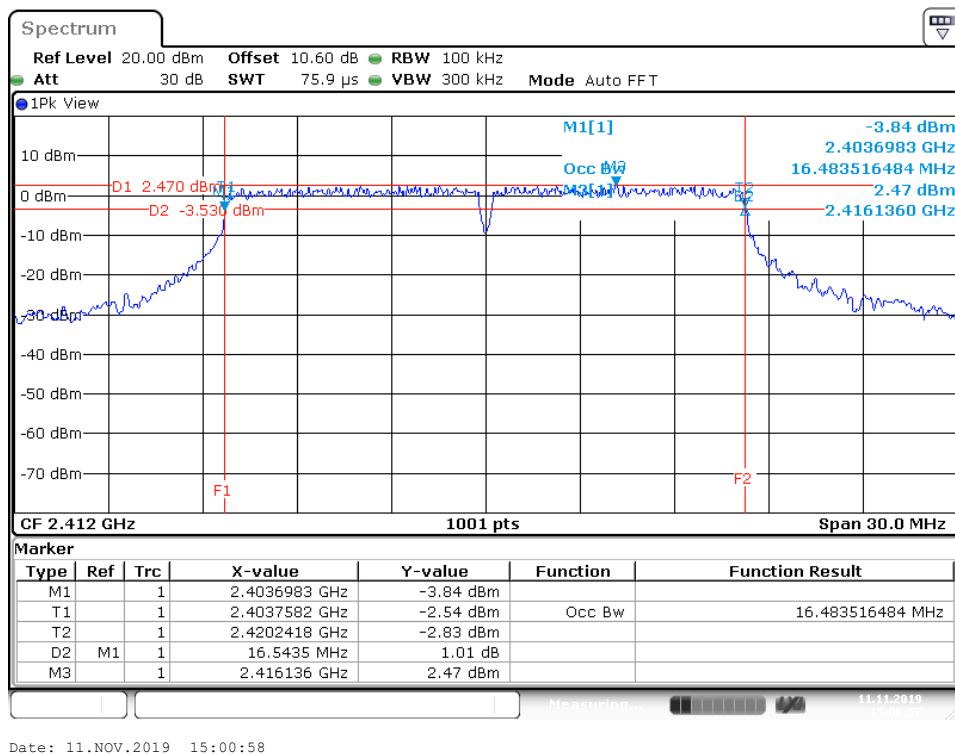
High Channel

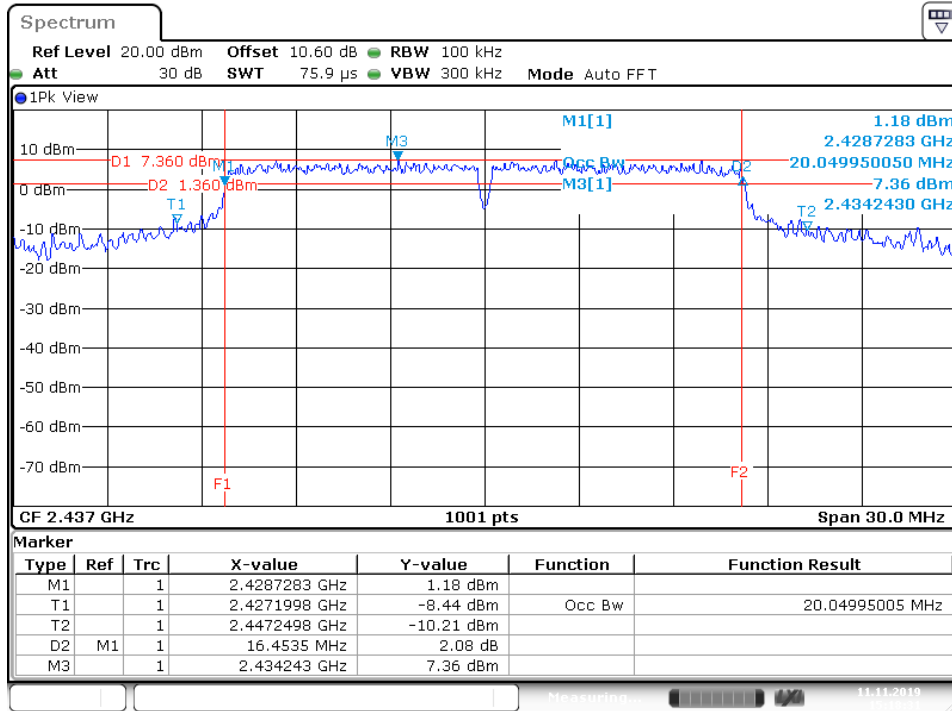
Test Plot of 6dB Bandwidth (802.11g)
Low Channel

Middle Channel

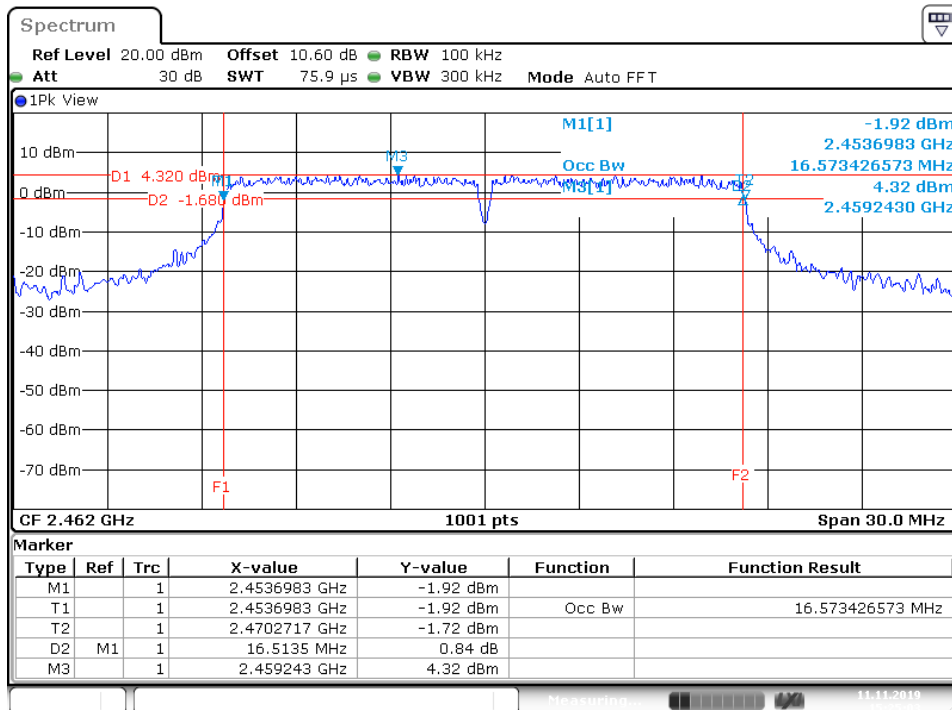
Date: 11.NOV.2019 15:18:31

High Channel

Date: 11.NOV.2019 15:25:04

Test Plot of 6dB Bandwidth (802.11n HT20)

Low Channel

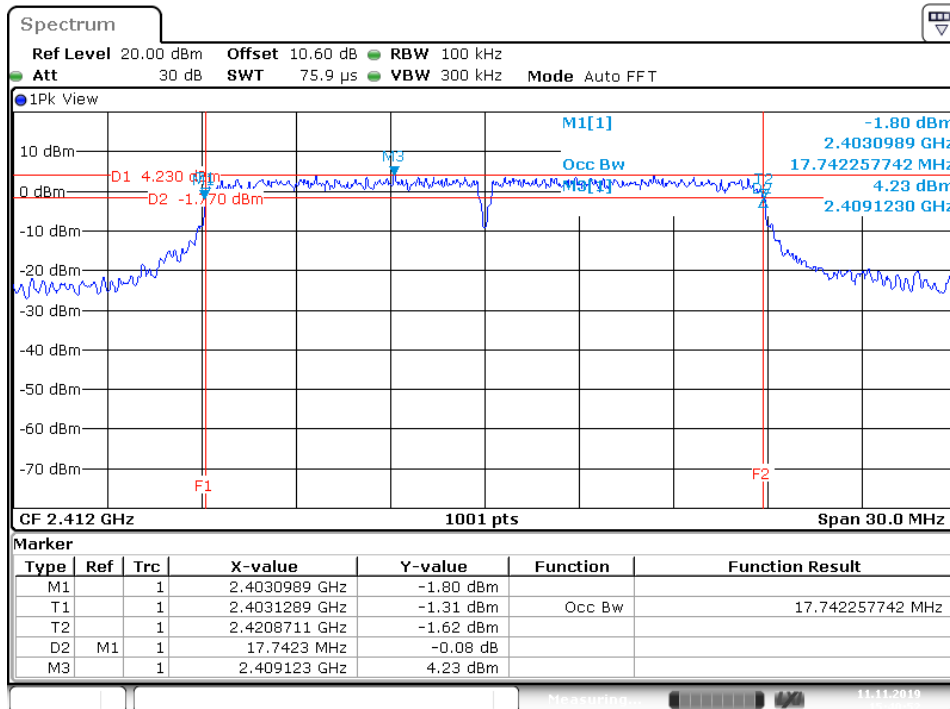

Date: 11.NOV.2019 15:40:53

Middle Channel

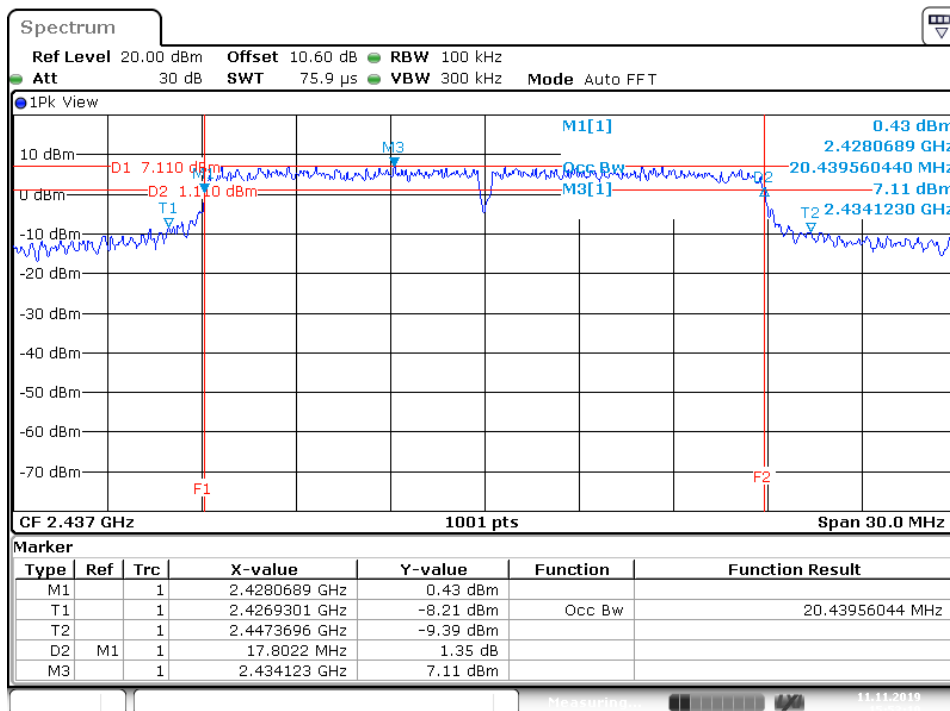

Date: 11.NOV.2019 15:53:10

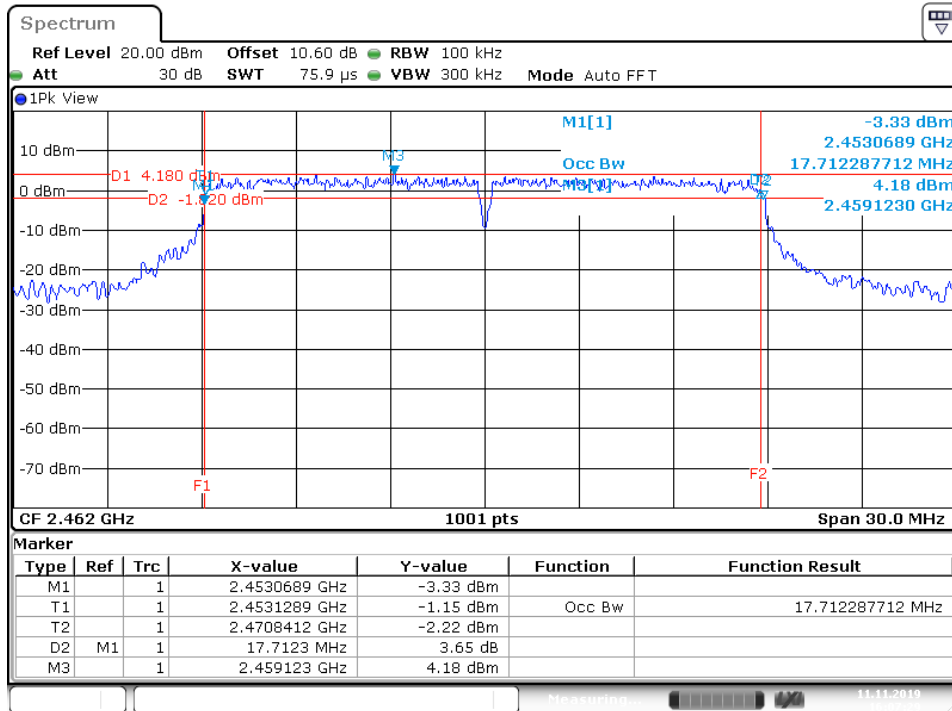
High Channel

Date: 11.NOV.2019 16:07:30

Test Plot of 99% Bandwidth (802.11b)

Low Channel

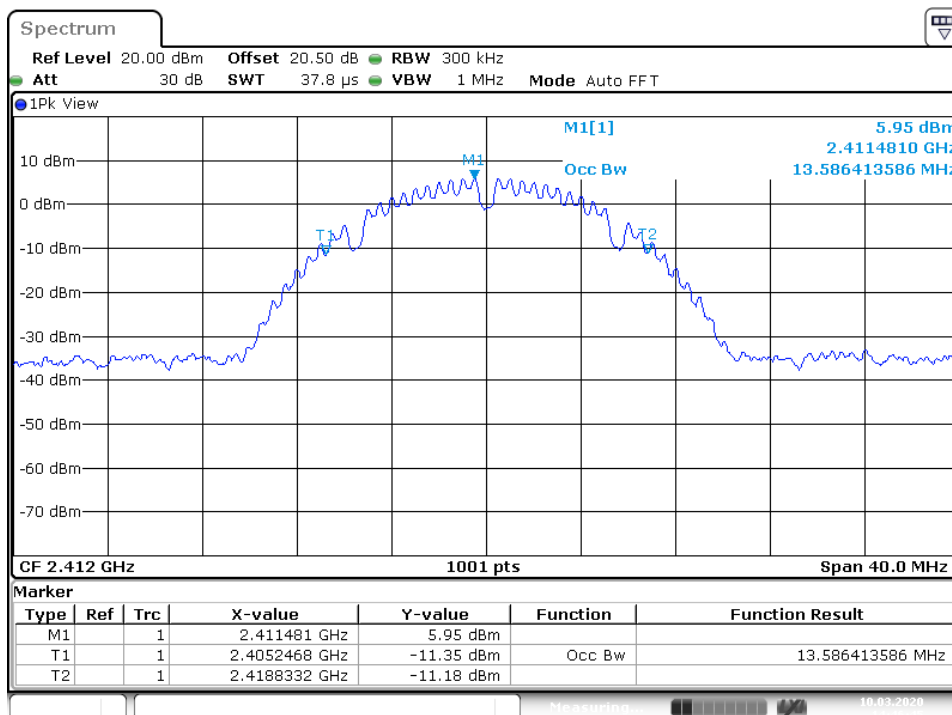

Date: 10.MAR.2020 14:46:45

Middle Channel

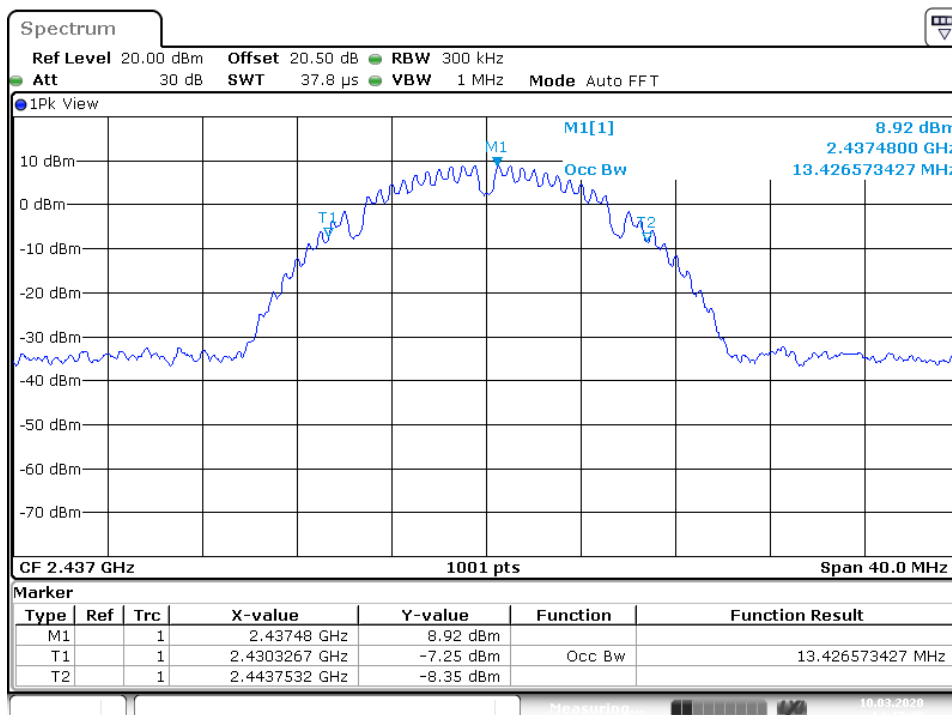

Date: 10.MAR.2020 14:47:25

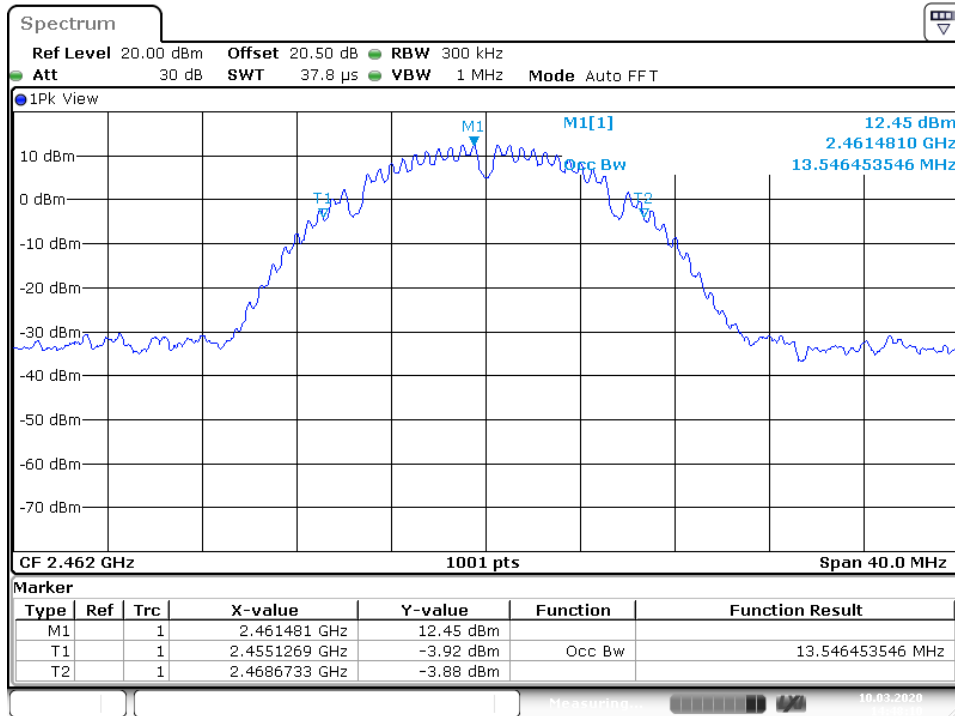
High Channel

Date: 10.MAR.2020 14:48:11

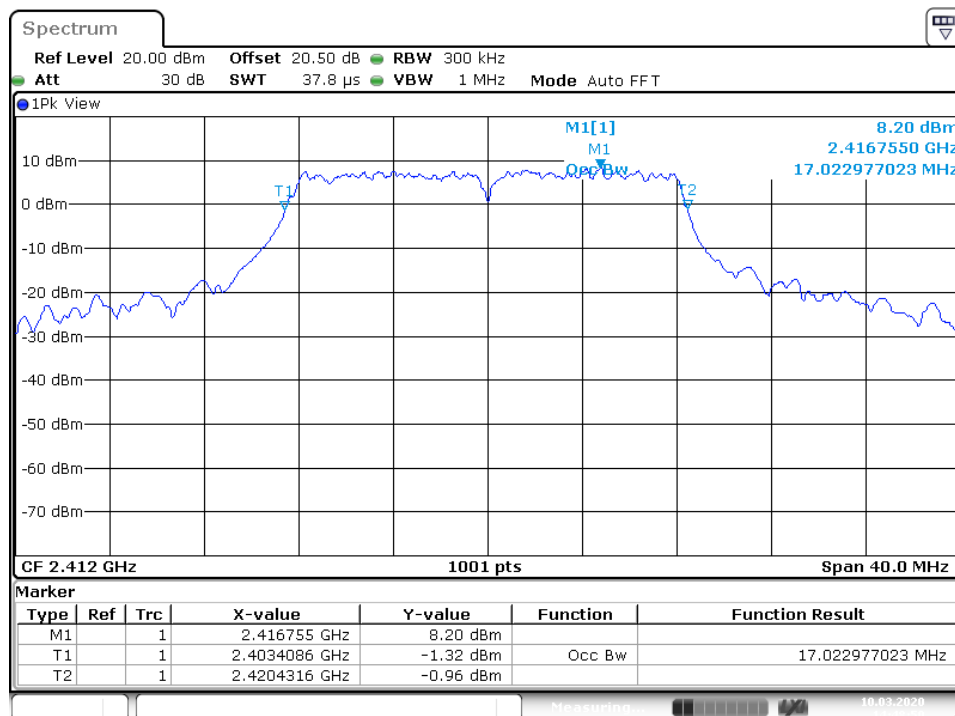
Test Plot of 99% Bandwidth (802.11g)
Low Channel

Date: 10.MAR.2020 14:48:50

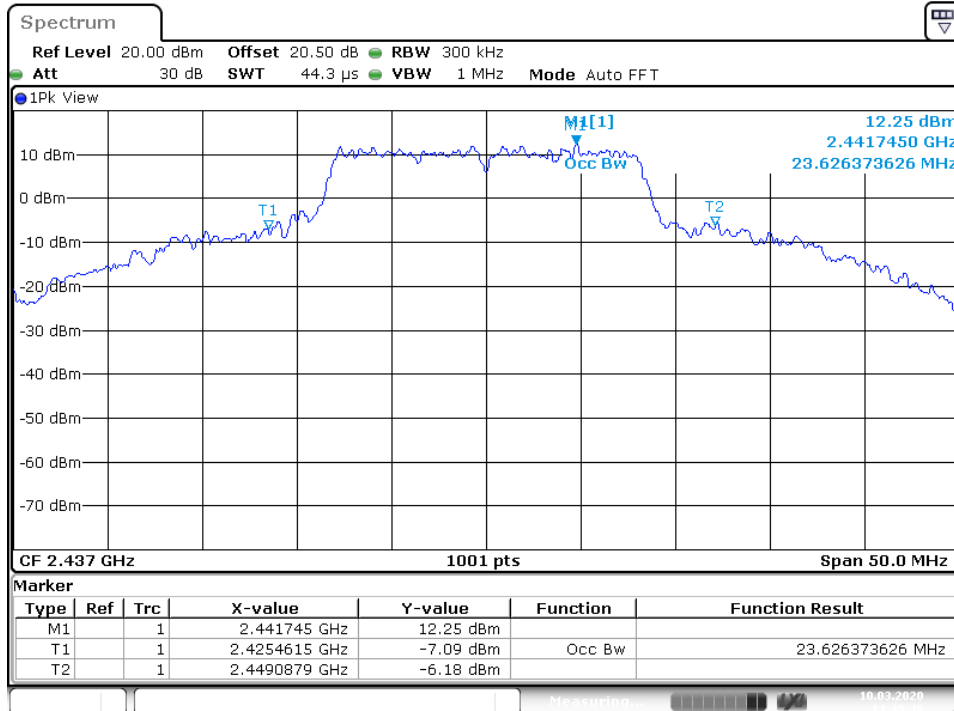
Middle Channel

Date: 10.MAR.2020 14:49:46

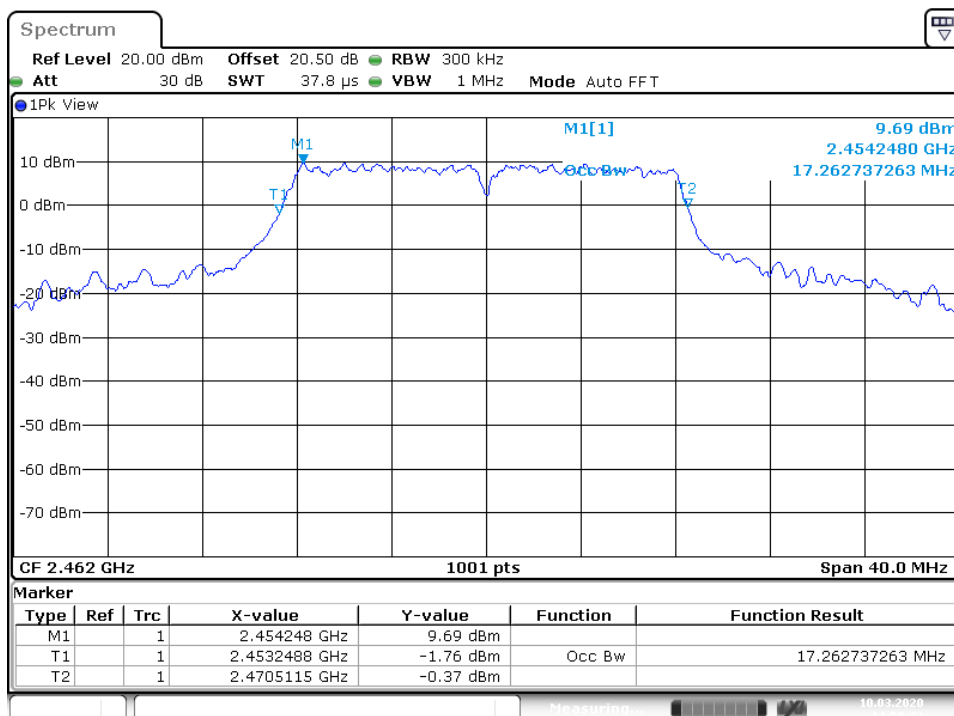
High Channel

Date: 10.MAR.2020 14:50:32

Test Plot of 99% Bandwidth (802.11n HT20)

Low Channel

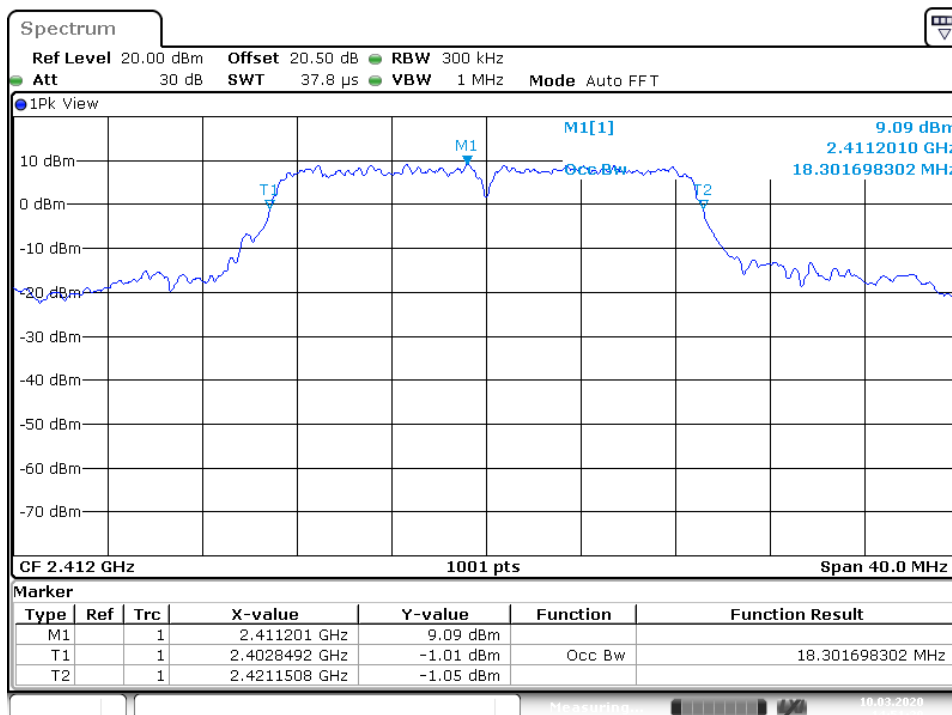

Date: 10.MAR.2020 14:51:29

Middle Channel

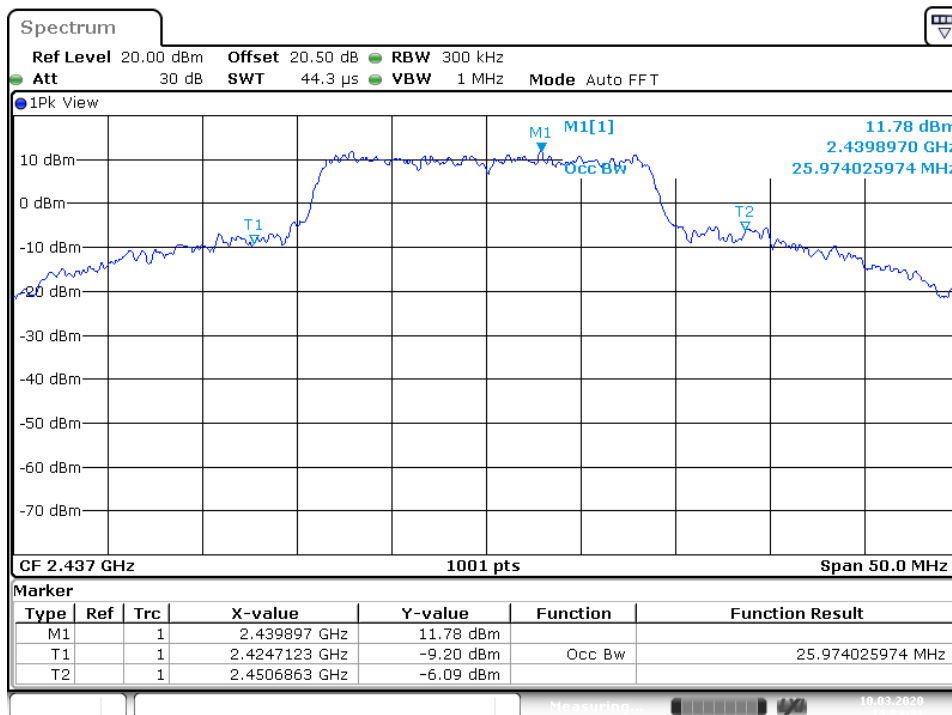

Date: 10.MAR.2020 14:52:31

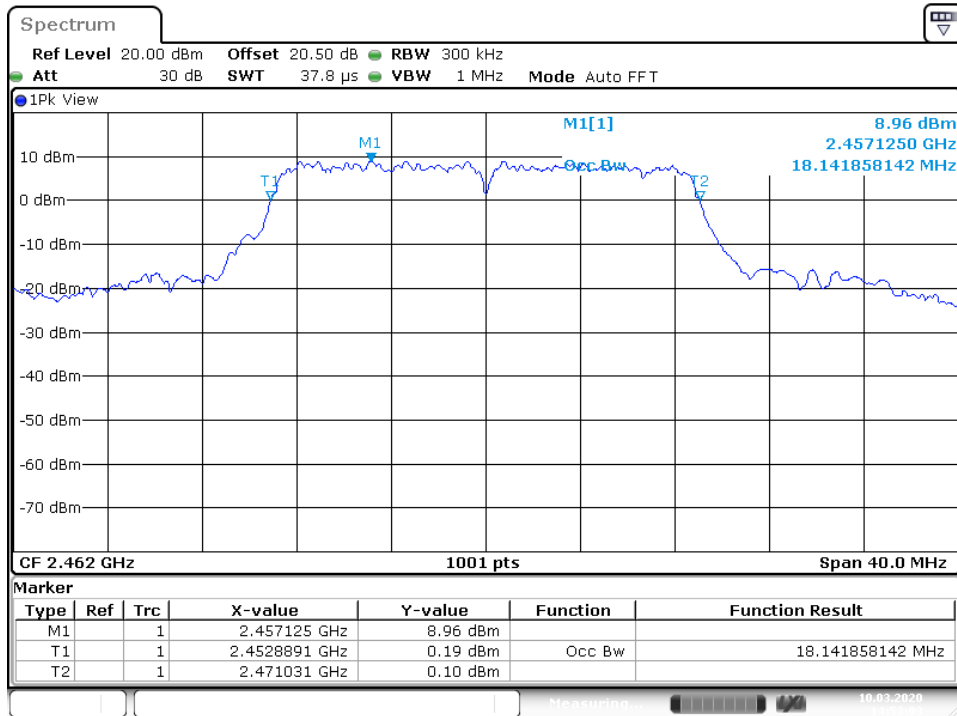
High Channel

Date: 10.MAR.2020 14:53:04

5.1.4 Power Density

RESULT:
Passed

Test standard : FCC Part 15.247(e) , RSS-247 5.2(2)
 Basic standard : ANSI C63.10:2013, KDB558074
 Kind of test site : Shielded room

Test setup

Test Channel : Low/ Middle/ High
 Operation Mode : A
 Test Lab : Linkou
 Ambient temperature : 22-26°C
 Relative humidity : 50-65%
 Atmospheric pressure : 100-103 kPa

Table 16: Test result of Power Density (802.11b)

Channel	Channel Frequency (MHz)	Power Density	Limit
		(dBm)	(dBm)
Low Channel	2412	-15.20	8
Middle Channel	2437	-13.38	8
High Channel	2462	-10.08	8

Table 17: Test result of Power Density (802.11g)

Channel	Channel Frequency (MHz)	Power Density	Limit
		(dBm)	(dBm)
Low Channel	2412	-12.13	8
Middle Channel	2437	-7.97	8
High Channel	2462	-10.11	8

Table 18: Test result of Power Density (802.11n HT20)

Channel	Channel Frequency (MHz)	Power Density	Limit
		(dBm)	(dBm)
Low Channel	2412	-9.99	8
Middle Channel	2437	-7.60	8
High Channel	2462	-9.72	8

Test Plot of Power Density (802.11b)

Low Channel

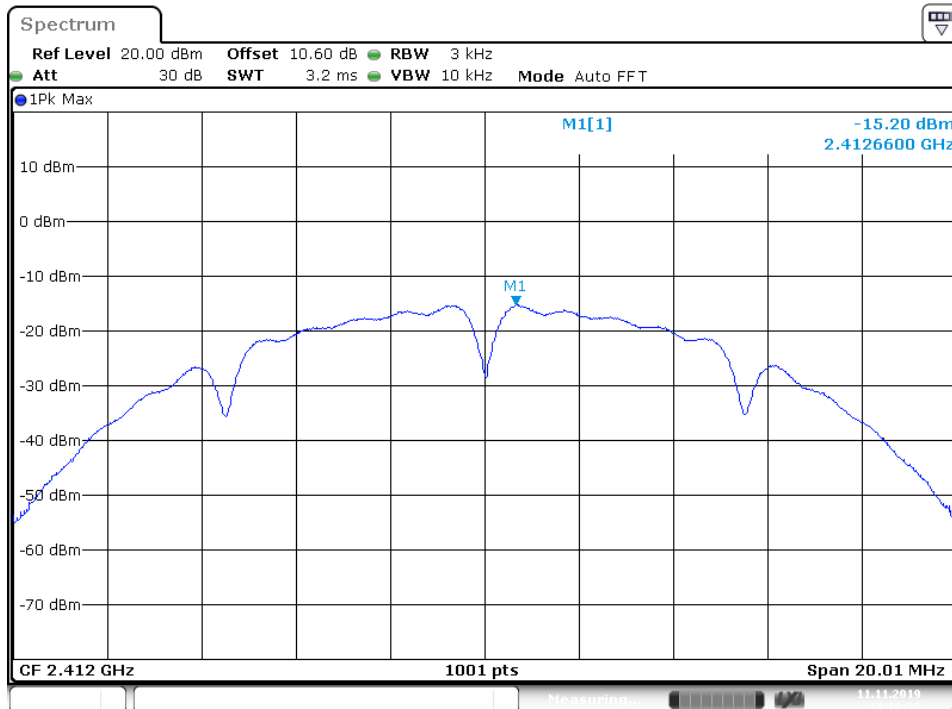

Middle Channel

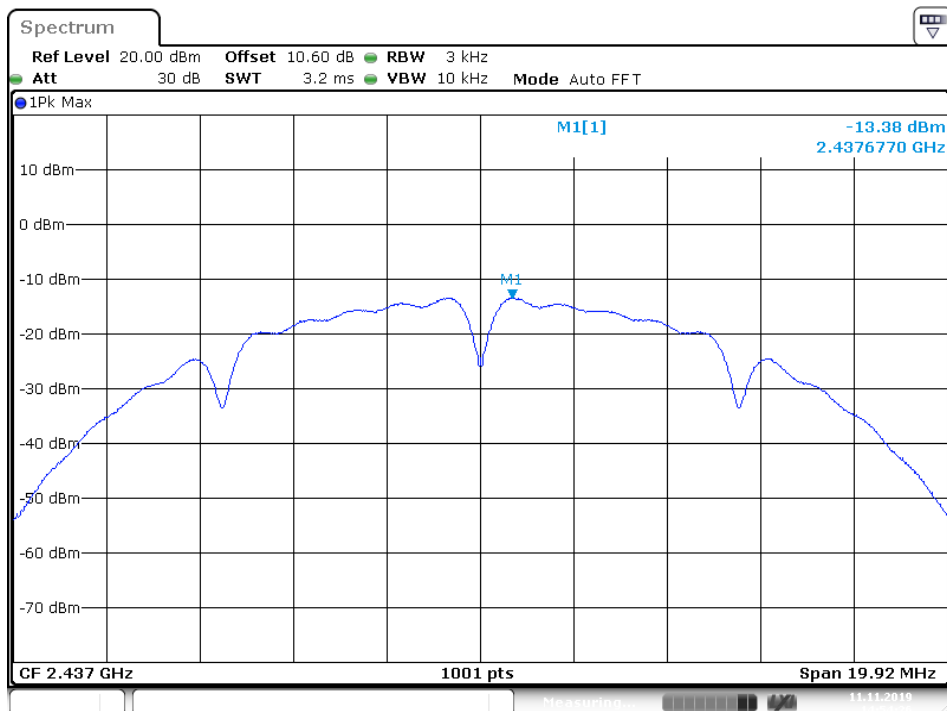

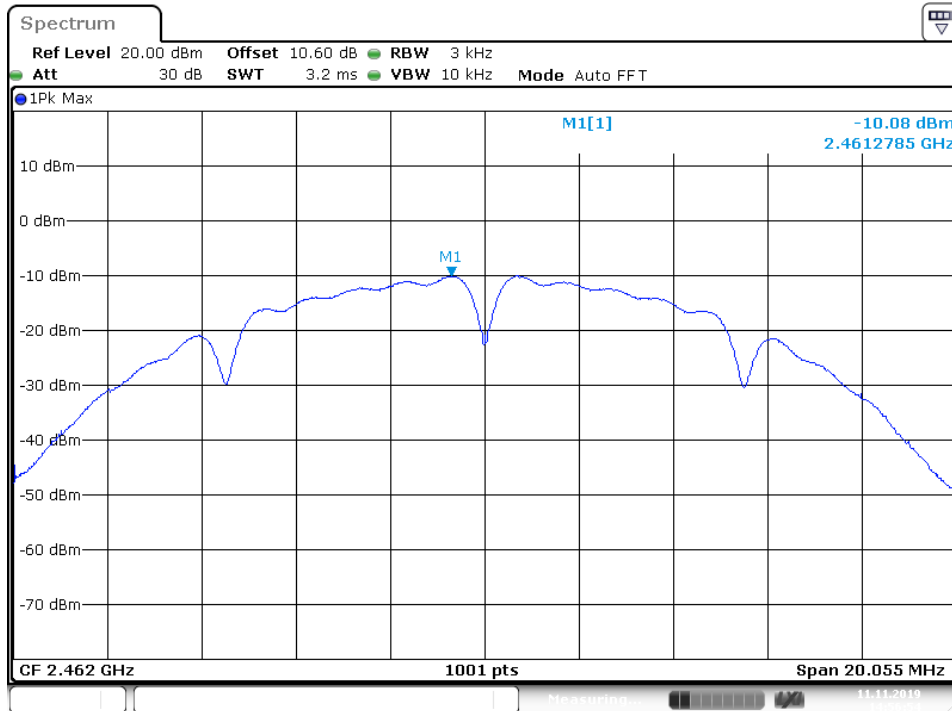
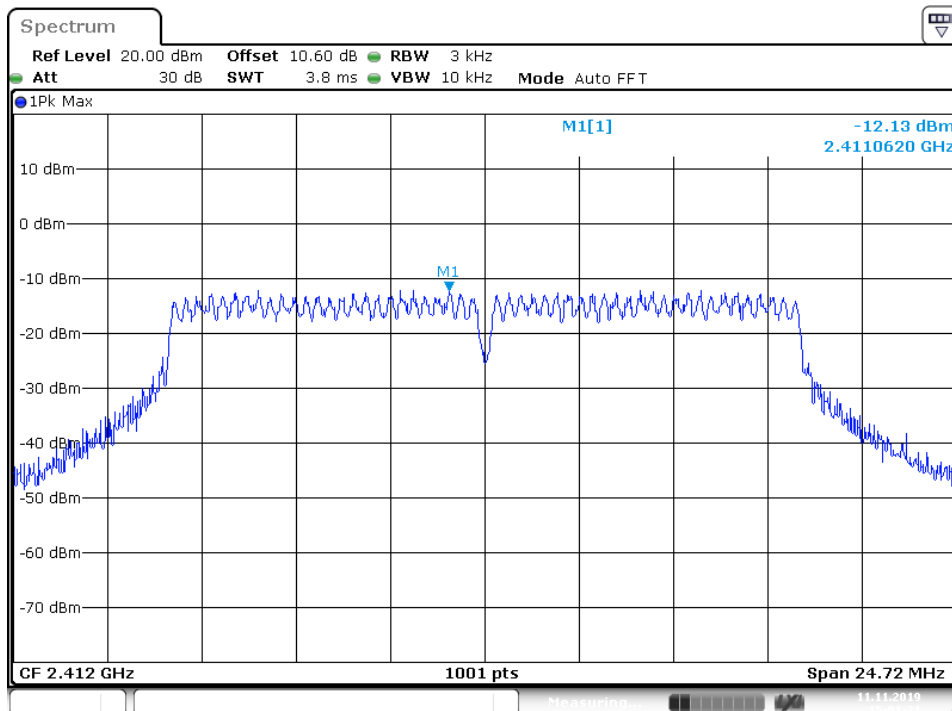
High Channel

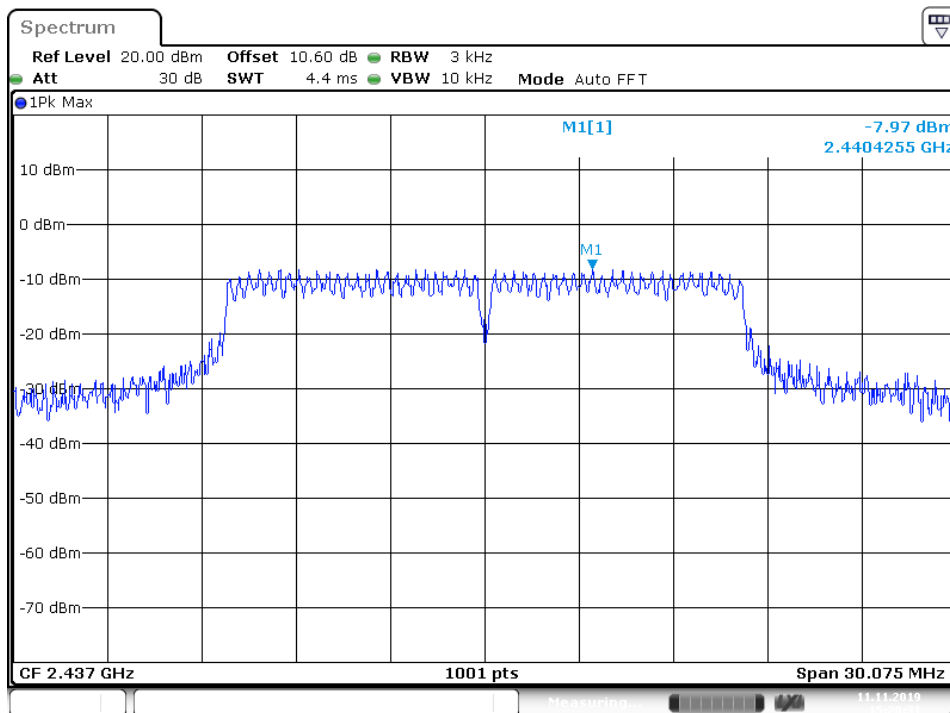
Test Plot of Power Density (802.11g)
Low Channel

Middle Channel

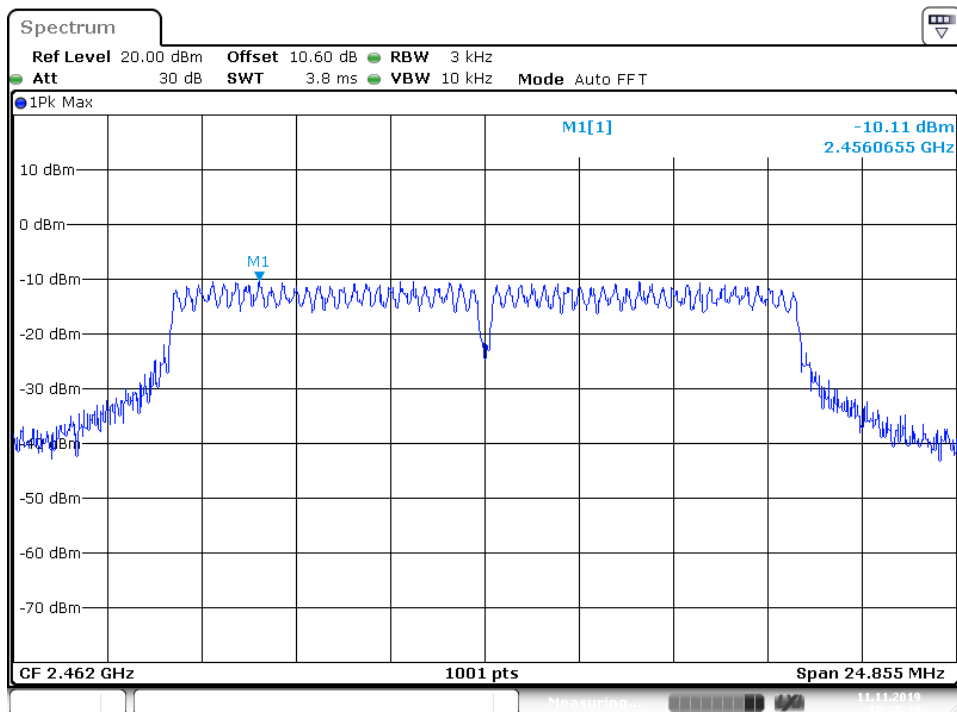
Date: 11.NOV.2019 15:20:31

High Channel

Date: 11.NOV.2019 15:25:39

Test Plot of Power Density (802.11n HT20)

Low Channel

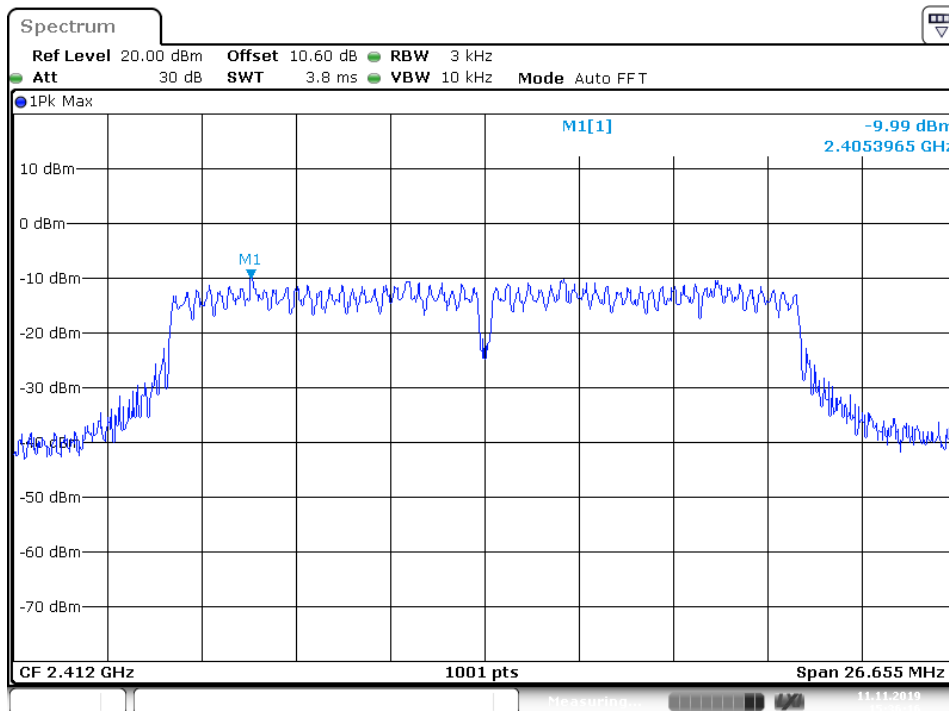

Middle Channel

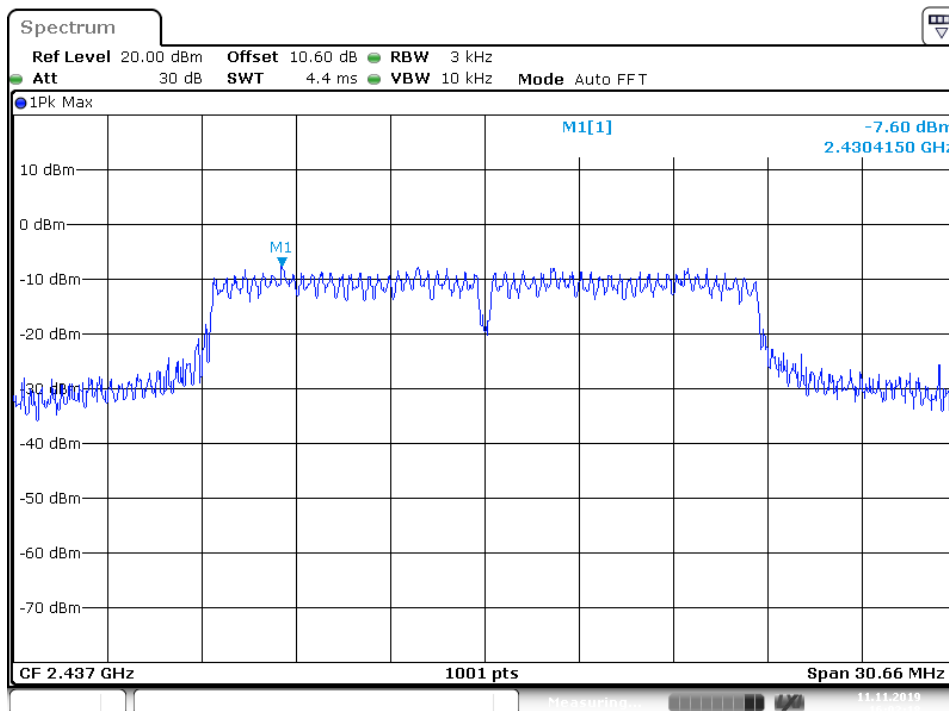

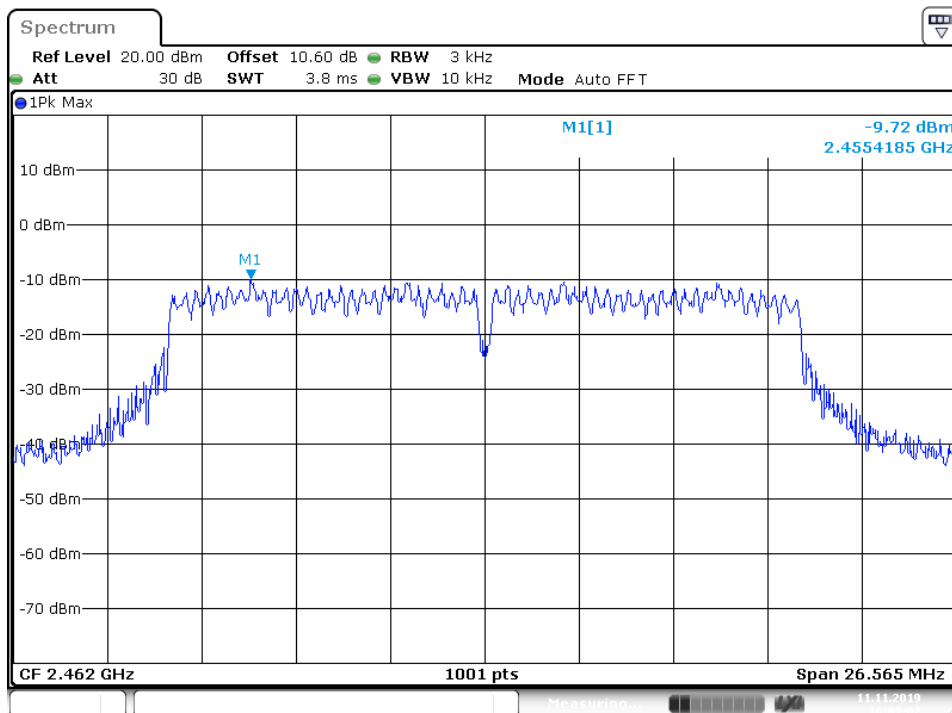
High Channel

Date: 11.NOV.2019 16:09:03

5.1.5 Conducted spurious emissions and Frequency Band Edge measured in 100kHz Bandwidth

RESULT:**Passed**

Test standard : FCC part 15.247(d), RSS-247 5.5
Basic standard : ANSI C63.10:2013, KDB558074
Limit : 20dB (below that in the 100kHz bandwidth within the band that contains the highest level of the desired power)
Kind of test site : Shielded room

Test setup

Test Channel : Low/ Middle/ High
Test Lab : Linkou
Ambient temperature : 22-26°C
Relative humidity : 50-65%
Atmospheric pressure : 100-103 kPa

All emissions are more than 20dB below fundamental, details refer to following test plot, and compliance is achieved as well.

Due to the small size of the product and that there are no inductive components of significant size connected to the antenna port, 9kHz to 30MHz frequency range is not tested based on technical judgment.

Test Plot 100kHz Conducted Emissions (802.11b)

Low Channel

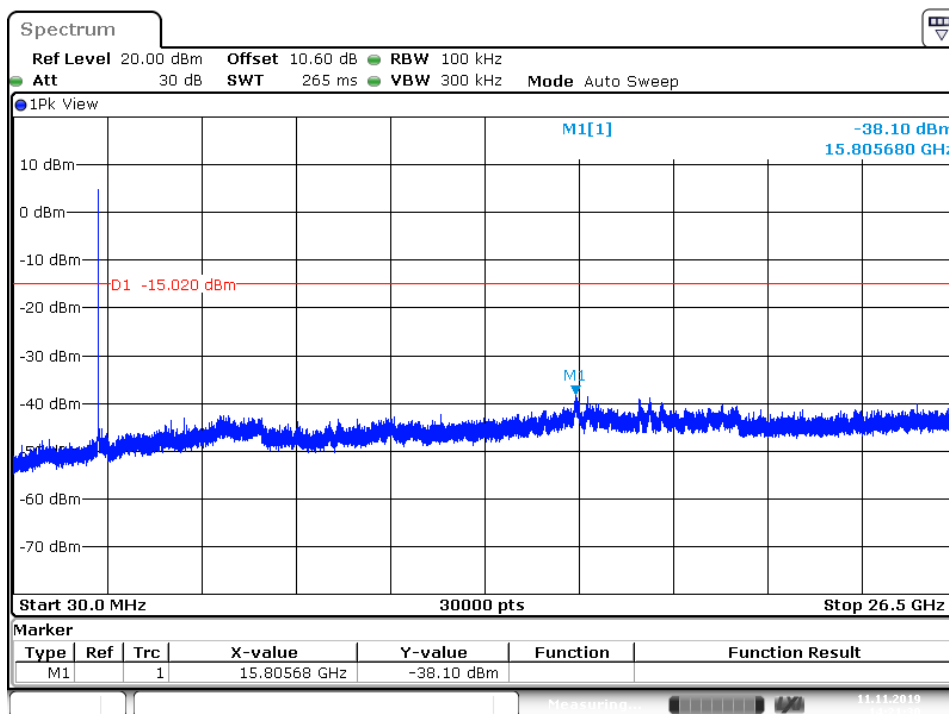

Middle Channel

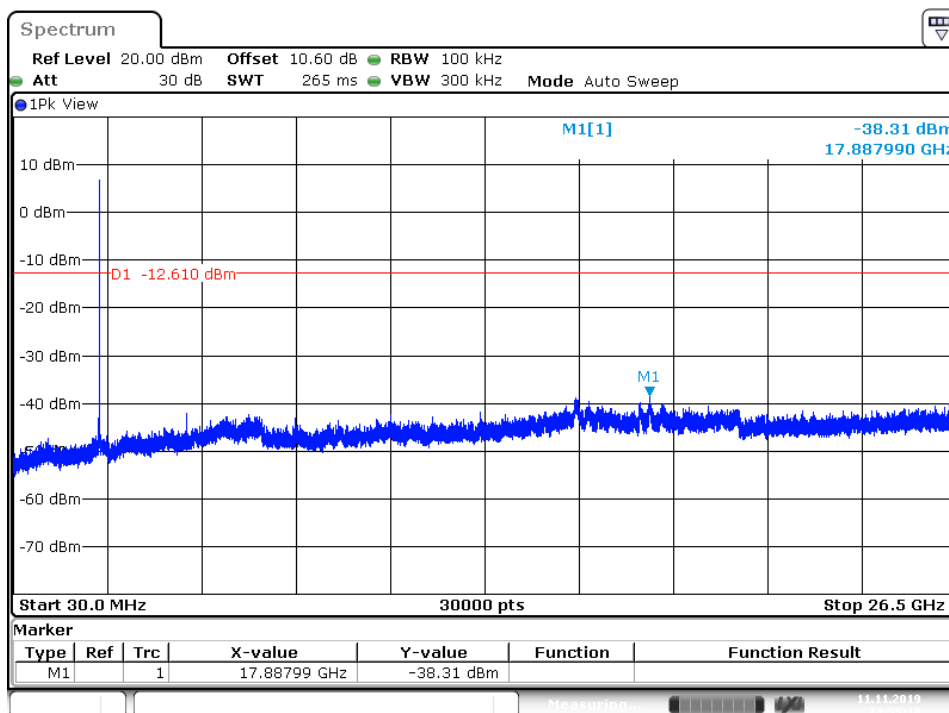

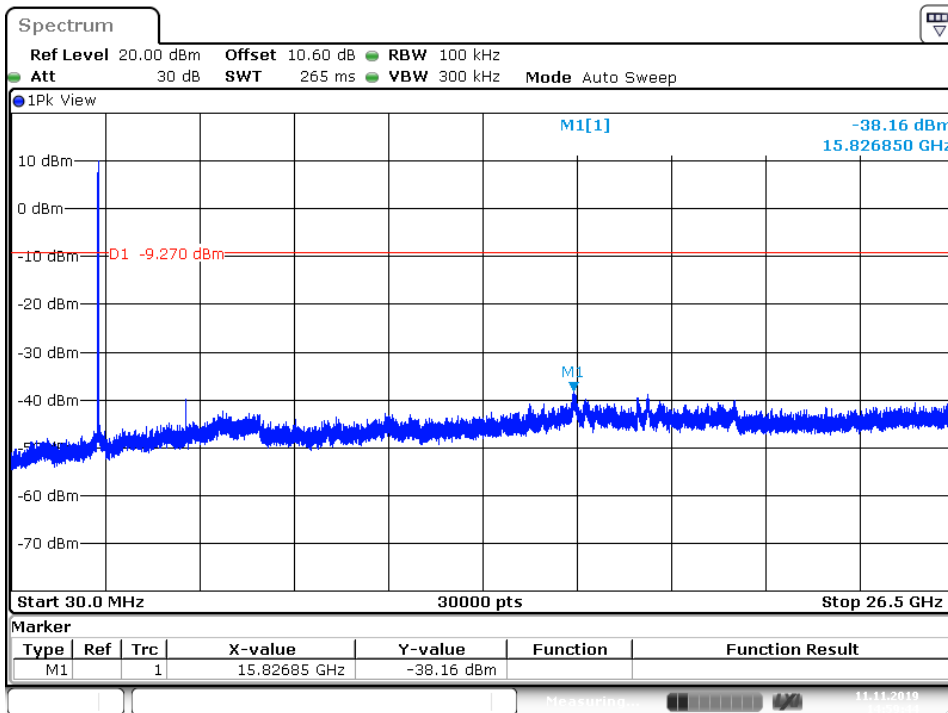
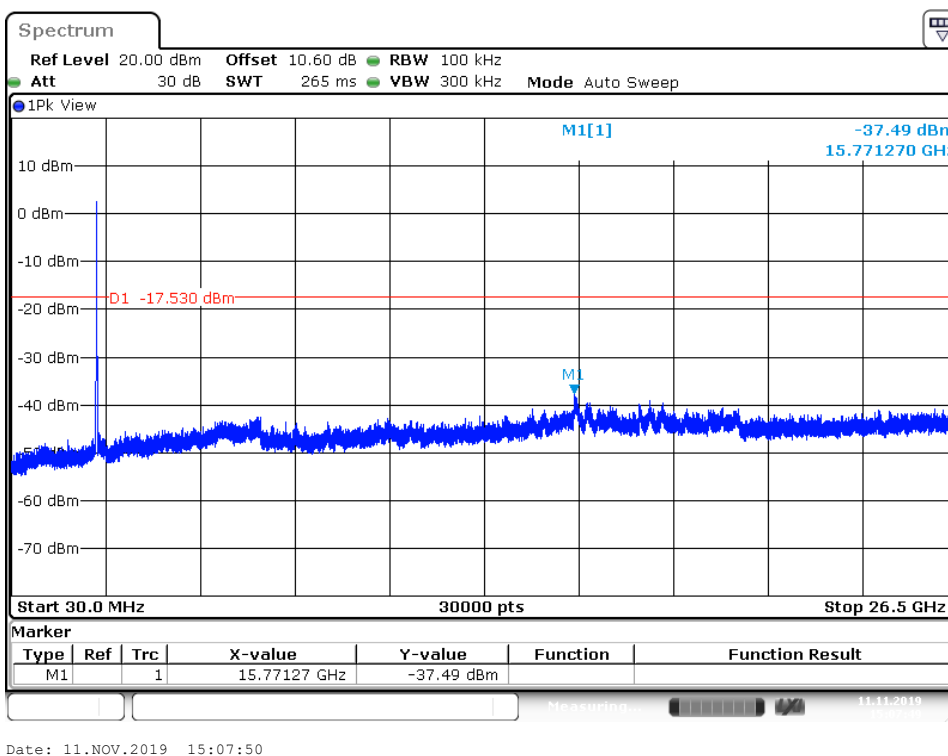
High Channel

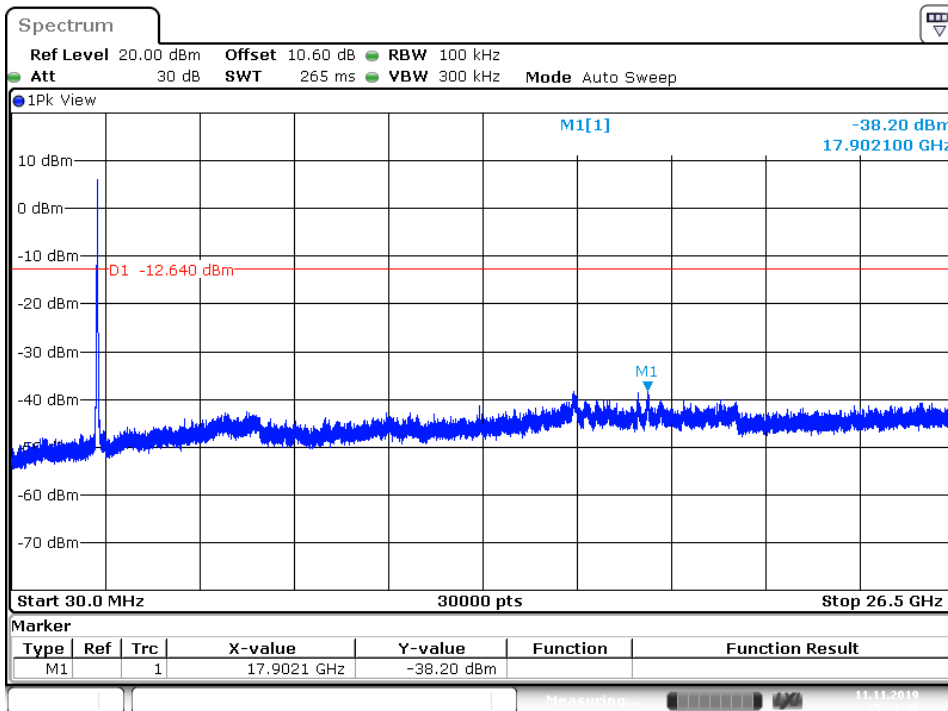
Test Plot 100kHz Conducted Emissions (802.11g)
Low Channel

Middle Channel

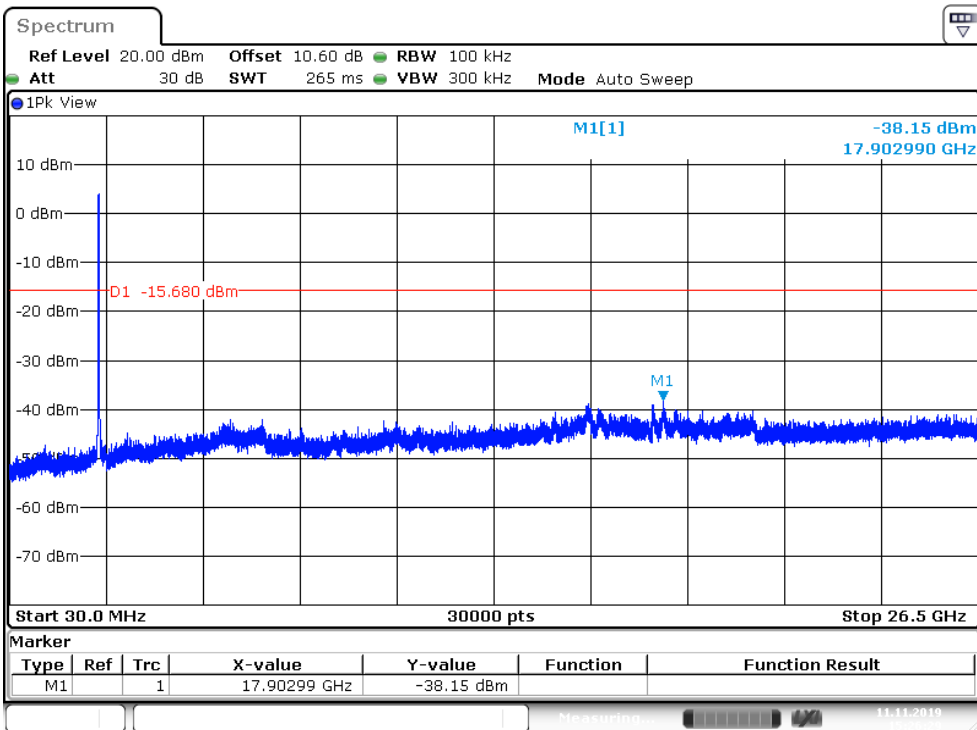
Date: 11.NOV.2019 15:21:40

High Channel

Date: 11.NOV.2019 15:26:29

Test Plot 100kHz Conducted Emissions (802.11n HT20)

Low Channel

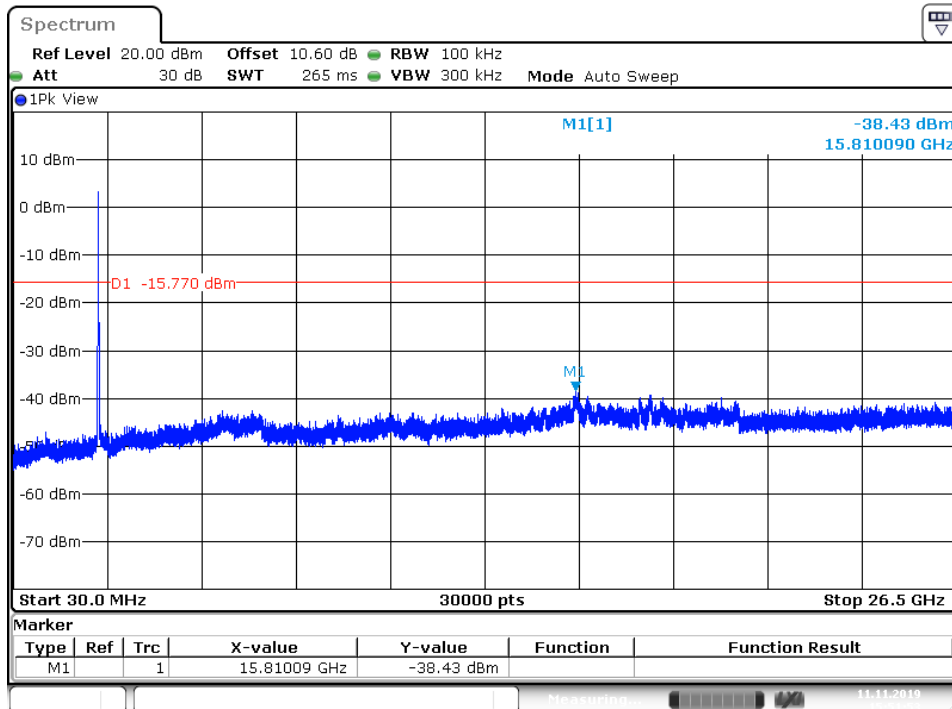

Date: 11.NOV.2019 15:51:54

Middle Channel

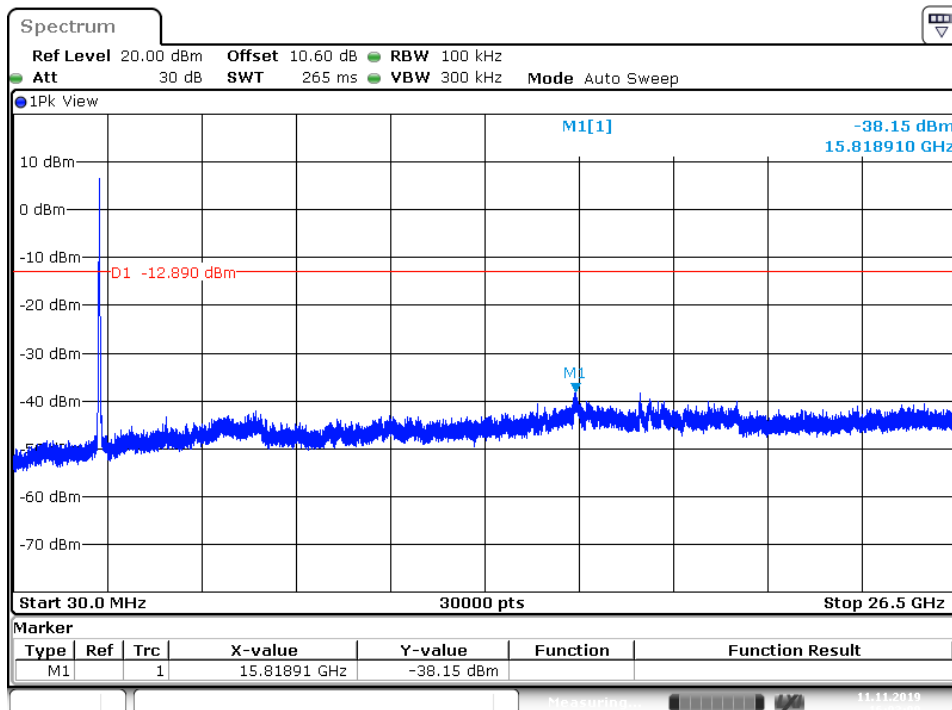

Date: 11.NOV.2019 16:03:01

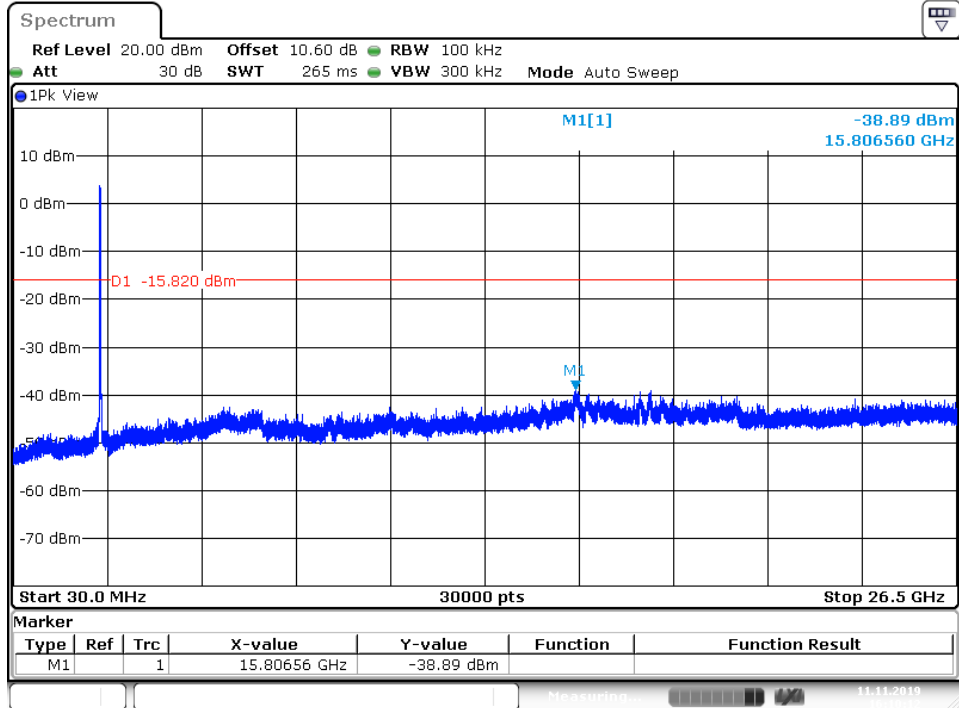
High Channel

Date: 11.NOV.2019 16:10:13

Test Plot 100kHz RBW of Band Edge (802.11b)

Low Channel

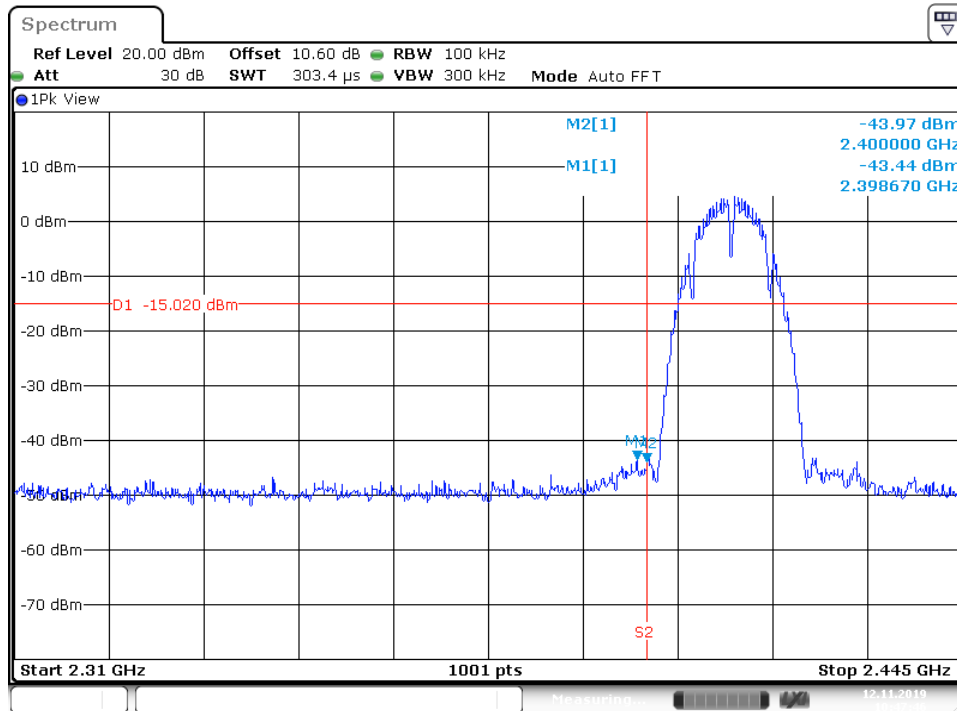

High Channel

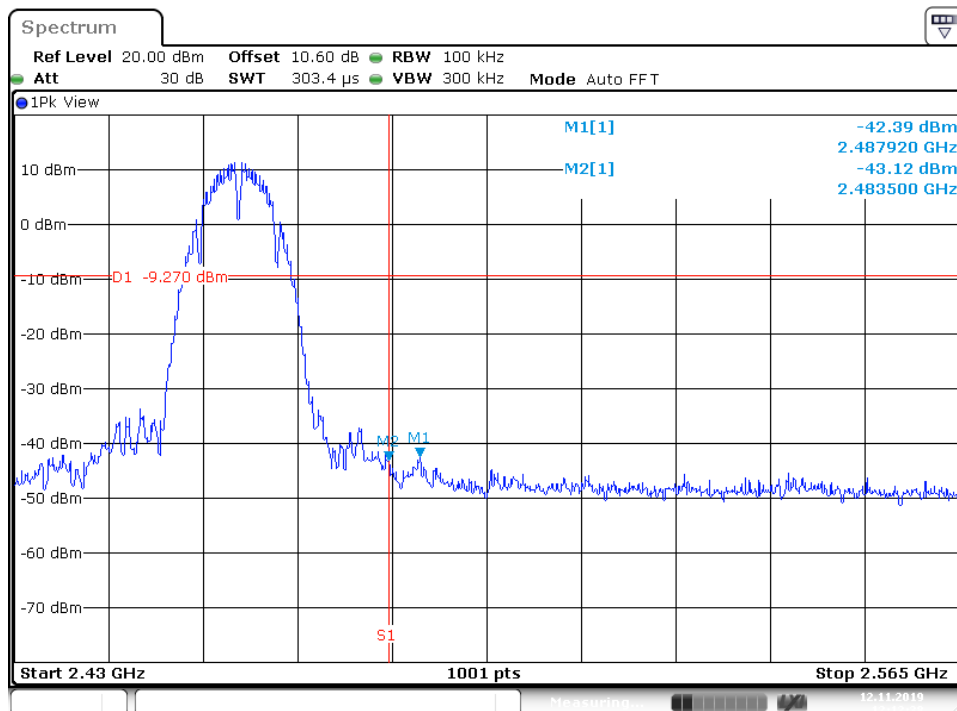

Test Plot 100kHz RBW of Band Edge (802.11g)

Low Channel

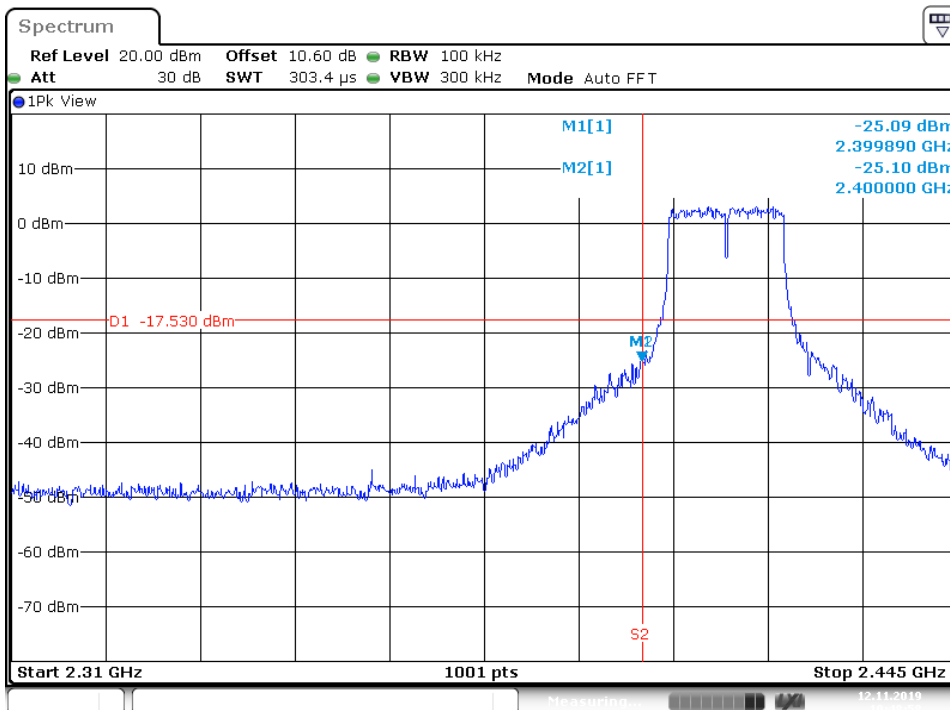

High Channel

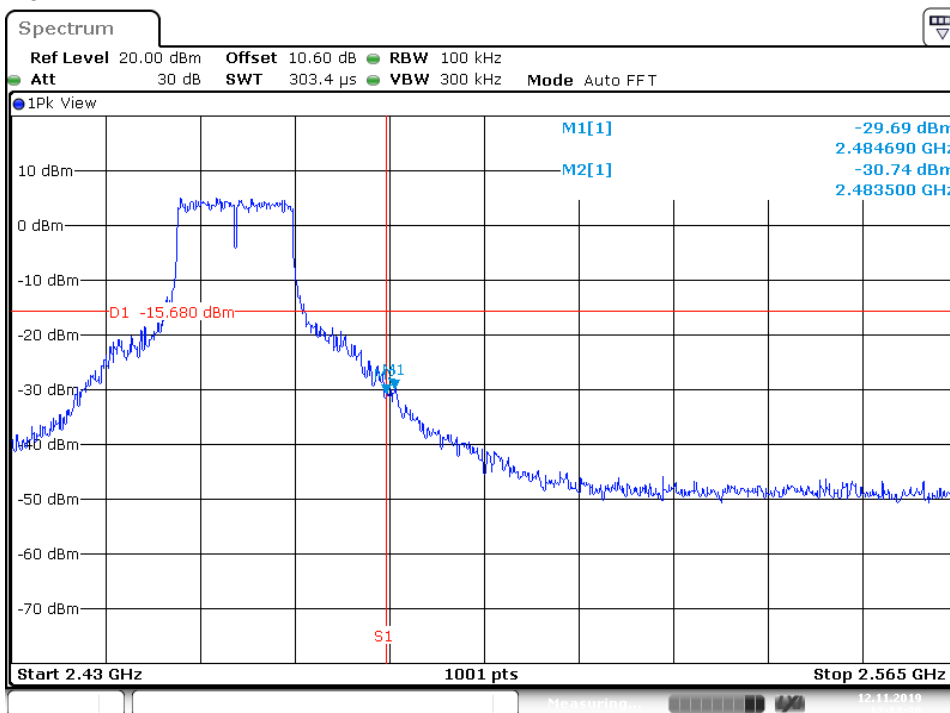

Test Plot 100kHz RBW of Band Edge (802.11n HT20)

Low Channel

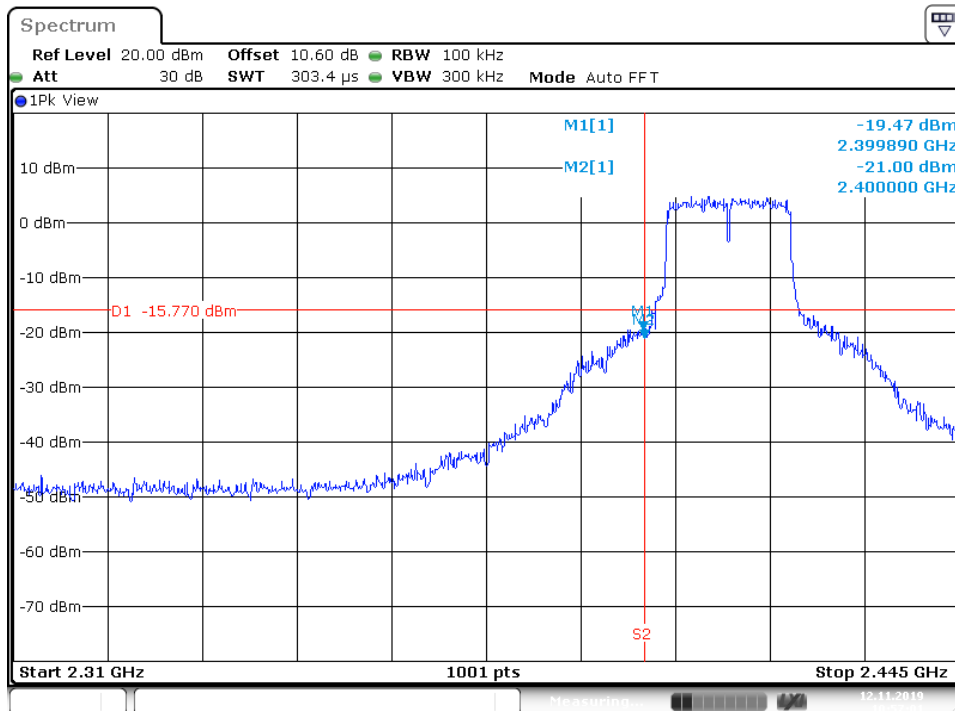

High Channel

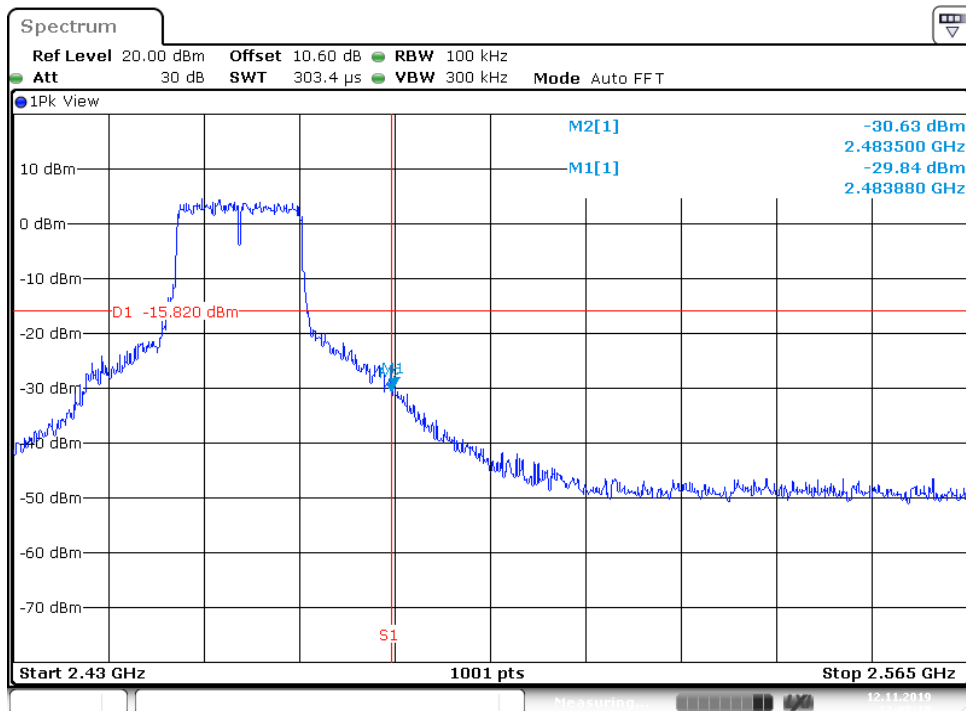

5.1.6 Spurious Emission

RESULT:**Passed**

Test standard : FCC part 15.247(d), FCC 15.205, FCC 15.209 and RSS-Gen 8.9

Basic standard : ANSI C63.10: 2013
Limits : Radiated emissions which fall in the restricted bands, as defined in FCC 15.205(a) and RSS-Gen i5, 8.10 (Table 7), must comply with the radiated emission limits specified in FCC 15.209(a) and RSS-Gen 5, 8.9 (Table 5 and 6).

Radiated emissions which fall in the restricted bands, as defined in LP0002(2018): 2.7, must comply with the radiated emission limits specified in LP0002(2018): 2.8

Emission radiated outside the restricted and authorized frequency bands must either comply with the radiated emission limits specified for the restricted bands or in FCC15.247(d) and RSS-247 i2, 5.5

Emission radiated outside the specified frequency bands must comply with the radiated emission limits specified in LP0002(2018): 2.8

Kind of test site : 3m Semi-Anechoic Chamber

Test setup

Test Channel : Low/ Middle/ High
Operation mode : A
Test Lab : Linkou

Remark: Testing was carried out within frequency range 9kHz to the tenth harmonic.

For details refer to Appendix D.

The Radiated Emissions testing was performed in the X, Y and Z axis orientation. The XAxis orientation is the worst-case and recorded in this test report.

5.2 Mains Emissions

5.2.1 Mains Conducted Emissions

RESULT:**Passed**

Test standard : FCC Part 15.207
FCC Part 15.107
RSS-Gen 8.8

Limits : Mains Conducted emissions as defined in
above standards

Kind of test site : Shielded Room

Test setup

Operation mode : C

Remark: For details refer to Appendix D.

6. Safety Human exposure

6.1 Radio Frequency Exposure Compliance

6.1.1 Electromagnetic Fields

RESULT: **Passed**

Test standard : FCC KDB Publication 447498 D01 v06
 RSS-102 Issue 5, 2.5.2

Separation distance is more than 20 cm, thus mobile device exposure limits can be applied:

FCC:

Maximum Exposure

802.11n HT20MHz

Frequency (MHz)	Antenna Gain (dBi)	Antenna Gain (numeric)	Output Power (dBm)	Output Power (mW)	Power Density (S)	Limit of Power Density (S)	Test Result
					(mW/cm ²)	(mW/cm ²)	
2437	-1.00	0.7943	20.7100	117.7606	0.018619	1	Complies

Power Density Limit for FCC:

1500-100,000 MHz 1.0 mW/cm²

ISED:

Exemption Limits for Routine Evaluation – RF Exposure Evaluation

At or above 300MHz and below 6 GHz and the source-based, time-averaged maximum e.i.r.p. of the device is equal to or less than $1.31 \times 10^{-2} f^{0.6834}$ W, where f is in MHz;

f= 2437MHz

$$1.31 \times 10^{-2} \times 2437^{0.6834} = 2.70W$$

After evaluation the 2437MHz e.i.r.p 19.71dBm calculated result is closer to its limit.

19.71dBm = 0.09354W, it is well below the limit of Exemption Limits for Routine Evaluation, so RF exposure assessment meets its standards.

---End---

7. List of Tables

Table 1: Applied Standard and Test Levels.....	5
Table 2: List of Test and Measurement Equipment.....	7
Table 3: Emission Measurement Uncertainty	8
Table 4: Basic Information of EUT.....	9
Table 5: Technical Specification of EUT.....	9
Table 6: Table for Parameters of Test Software Setting.....	11
Table 7: Test result of Peak Output Power (802.11b)	16
Table 8: Test result of Peak Output Power (802.11g)	16
Table 9: Test result of Peak Output Power (802.11n HT20).....	17
Table 10: Test result of 6dB Bandwidth (802.11b).....	19
Table 11: Test result of 6dB Bandwidth (802.11g).....	19
Table 12: Test result of 6dB Bandwidth (802.11n HT20)	19
Table 13: Test result of 99% Bandwidth (802.11b).....	20
Table 14: Test result of 99% Bandwidth (802.11g).....	20
Table 15: Test result of 99% Bandwidth (802.11n HT20).....	20
Table 16: Test result of Power Density (802.11b).....	31
Table 17: Test result of Power Density (802.11g).....	31
Table 18: Test result of Power Density (802.11n HT20)	31