

## INSTRUCTIONS OF REMOTE CONTROL

### REMOTE CONTROL

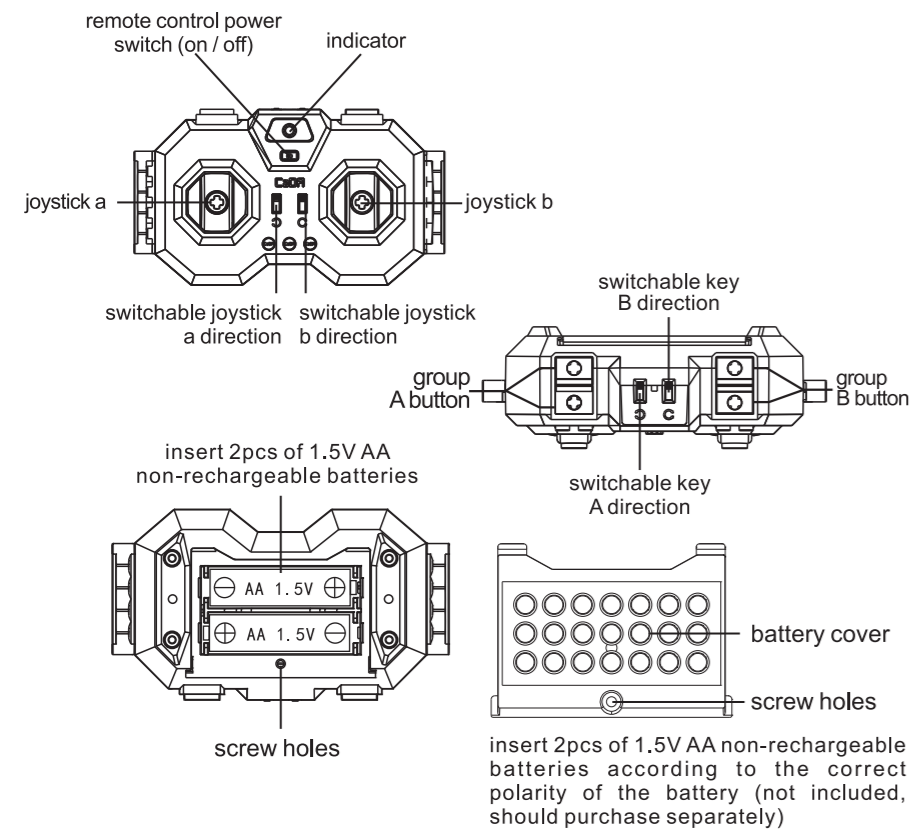

### CHARGER

charging output: 5V-2A (not recommended to use a higher power charger)



The main parts of the toy have overload protection function. When connected to overload or faulty components, it will automatically power-off (it can't work), need to charge it for more than 2 seconds to recover.

### BATTERY CASE

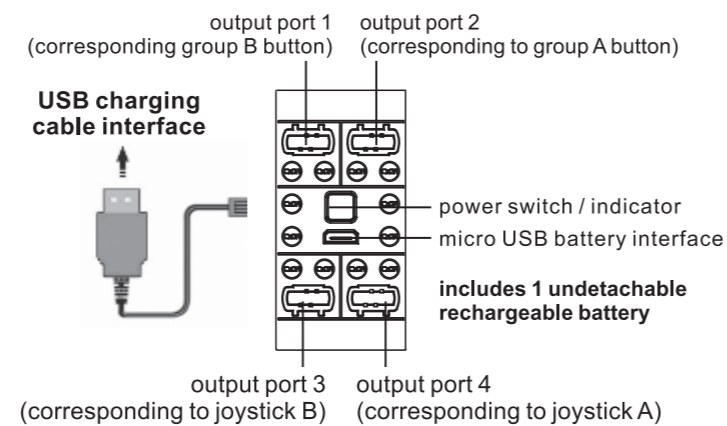

### ATTENTION

1. You must charge the product when using it for the first time. The charger output current and charging line have an effect on the charging time.
2. When charging, the green light flashes to indicate that the charging is normal; the green light does not flash when the charging has been completed; charge for more than 3 hours to play.
3. The output port can only be used with the matching plug the product.
4. The output port can not touch the metal (conductive) surface. Please pay attention when placing and avoid damaging the product.
5. This toy contains batteries that are non-replaceable.

### 2.4GHz AUTOMATICAL CODE DESCRIPTION

1. When the remote control is equipped with the battery, press the power switch of it, and the indicator light of the remote control flashes slowly and starts to match the code; Press the power switch of the battery box again, the indicator light of the battery box will change from flashing into long bright. In the meanwhile, the indicator light of the remote control will flash twice, and then goes out, indicating the success of the code.
2. Each remote control can only pair with one battery box. When the pairing code is successful, each battery box does not interfere with each other.
3. If the remote control or the battery box don't get the 2.4G signal from corresponding battery box or remote control after 2 minutes, or does not have any button operation after about 4 minutes in a successful code state, it will automatically shut down. Need to press its power switch again to continue to use.
4. Turn off the power to re-pair the code with the other remote control or battery box.

The instruction manual must be retained since it contains important information.

Frequency bands: 2405MHz to 2475MHz  
Maximum output power: <2dBm

Manufacturer: Doubleeagle Industry (China) Limited.  
Address: Xingda Industrial Park, Chenghai  
District, Shantou City, Guangdong Province, China.

Importer: Toy Planet  
Address: Parque Empresarial Tactica  
C/Velluters, 37  
46980 Paterna

CHOKING HAZARD-small parts, not for children under 3 years.  
Specifications colors and contents may vary from illustrations.

This equipment has been tested and found to comply with the limits for a Class B digital device, pursuant to part 15 of the FCC Rules. These limits are designed to provide reasonable protection against harmful interference in a residential installation. This equipment generates, uses and can radiate radio frequency energy and, if not installed and used in accordance with the instructions, may cause harmful interference to radio communications. However, there is no guarantee that interference will not occur in a particular installation. If this equipment does cause harmful interference to radio or television reception, which can be determined by turning the equipment off and on, the user is encouraged to try to correct the interference by one or more of the following measures:

--Reorient or relocate the receiving antenna.

--Increase the separation between the equipment and receiver.

--Connect the equipment into an outlet on a circuit different from that to which the receiver is connected.

--Consult the dealer or an experienced radio/TV technician for help.

MODIFICATION: Any changes or modifications not expressly approved by the grantee of this device could void the user's authority to operate the device.

This device complies with Part 15 of the FCC Rules. Operation is subject to the following two conditions: (1) this device may not cause harmful interference, and (2) this device must accept any interference received, including interference that may cause undesired operation.

### Battery Usage Notices

- Insert/change batteries as per the correct polarity.
- Non-rechargeable batteries are not rechargeable.
- Do not mix old and new batteries, nor mix different types of batteries.
- Take out the exhausted batteries from the toy.
- The toy is not to be connected to more than recommended number of power supplies.
- The toy is not intended for children under 3 years old.
- Regularly check the wire, shell and other components for any damage. Stop using when the damage is founded, the supply terminals are not to be short-circuited.
- Unscrew the battery cover with the screwdriver, and insert the batteries as per the correct polarity.
- Do not mix alkaline batteries, standard (carbon-zinc) or rechargeable batteries.