

FCC Test Report (DFS Band)

Report No.: RF170209C07A-1

FCC ID: 2AAEDWP2117

Test Model: WiCS-2100

Received Date: Feb. 09, 2017

Test Date: Mar. 03 to 16, 2017

Issued Date: May 06, 2017

Applicant: Barco NV

Address: President Kennedypark 35, 8500 Kortrijk, Belgium

Issued By: Bureau Veritas Consumer Products Services (H.K.) Ltd., Taoyuan Branch
Hsin Chu Laboratory

Lab Address: E-2, No.1, Li Hsin 1st Road, Hsinchu Science Park, Hsinchu City 300,
Taiwan R.O.C.

Test Location (1): E-2, No.1, Li Hsin 1st Road, Hsinchu Science Park, Hsinchu City 300,
Taiwan R.O.C.

Test Location (2): No. 49, Ln. 206, Wende Rd., Shangshan Tsuen, Chiung Lin Hsiang, Hsin
Chu Hsien 307, Taiwan R.O.C.



This report is for your exclusive use. Any copying or replication of this report to or for any other person or entity, or use of our name or trademark, is permitted only with our prior written permission. This report sets forth our findings solely with respect to the test samples identified herein. The results set forth in this report are not indicative or representative of the quality or characteristics of the lot from which a test sample was taken or any similar or identical product unless specifically and expressly noted. Our report includes all of the tests requested by you and the results thereof based upon the information that you provided to us. You have 60 days from date of issuance of this report to notify us of any material error or omission caused by our negligence, provided, however, that such notice shall be in writing and shall specifically address the issue you wish to raise. A failure to raise such issue within the prescribed time shall constitute your unqualified acceptance of the completeness of this report, the tests conducted and the correctness of the report contents. Unless specific mention, the uncertainty of measurement has been explicitly taken into account to declare the compliance or non-compliance to the specification. The report must not be used by the client to claim product certification, approval, or endorsement by TAF or any government agencies.

Table of Contents

Release Control Record	4
1 Certificate of Conformity	5
2 Summary of Test Results	6
2.1 Measurement Uncertainty	6
2.2 Modification Record	6
3 General Information	7
3.1 General Description of EUT	7
3.2 Description of Test Modes	9
3.2.1 Test Mode Applicability and Tested Channel Detail	10
3.3 Duty Cycle of Test Signal	12
3.4 Description of Support Units	13
3.4.1 Configuration of System under Test	14
3.5 General Description of Applied Standard	16
4 Test Types and Results	17
4.1 Radiated Emission and Bandedge Measurement	17
4.1.1 Limits of Radiated Emission and Bandedge Measurement	17
4.1.2 Test Instruments	18
4.1.3 Test Procedure	20
4.1.4 Deviation from Test Standard	20
4.1.5 Test Setup	21
4.1.6 EUT Operating Condition	22
4.1.7 Test Results	23
4.2 Conducted Emission Measurement	43
4.2.1 Limits of Conducted Emission Measurement	43
4.2.2 Test Instruments	43
4.2.3 Test Procedure	44
4.2.4 Deviation from Test Standard	44
4.2.5 Test Setup	44
4.2.6 EUT Operating Condition	44
4.2.7 Test Results (Mode 1)	45
4.2.8 Test Results (Mode 2)	47
4.3 Transmit Power Measurement	49
4.3.1 Limits of Transmit Power Measurement	49
4.3.2 Test Setup	49
4.3.3 Test Instruments	49
4.3.4 Test Procedure	50
4.3.5 Deviation from Test Standard	50
4.3.6 EUT Operating Condition	50
4.3.7 Test Result	51
4.4 Occupied Bandwidth Measurement	56
4.4.1 Test Setup	56
4.4.2 Test Instruments	56
4.4.3 Test Procedure	56
4.4.4 Test Results	57
4.5 Peak Power Spectral Density Measurement	63
4.5.1 Limits of Peak Power Spectral Density Measurement	63
4.5.2 Test Setup	63
4.5.3 Test Instruments	63
4.5.4 Test Procedure	63
4.5.5 Deviation from Test Standard	63
4.5.6 EUT Operating Condition	63
4.5.7 Test Results	64
4.6 Frequency Stability Measurement	67

4.6.1	Limits of Frequency Stability Measurement	67
4.6.2	Test Setup.....	67
4.6.3	Test Instruments	67
4.6.4	Test Procedure	67
4.6.5	Deviation from Test Standard	67
4.6.6	EUT Operating Condition	67
4.6.7	Test Results	68
5	Pictures of Test Arrangements.....	69
	Appendix – Information on the Testing Laboratories	70

Release Control Record

Issue No.	Description	Date Issued
RF170209C07A-1	Original release.	May 06, 2017

1 Certificate of Conformity

Product: WiCS-2100
Brand: wePresent
Test Model: WiCS-2100
Sample Status: ENGINEERING SAMPLE
Applicant: Barco NV
Test Date: Mar. 03 to 16, 2017
Standard: 47 CFR FCC Part 15, Subpart E (Section 15.407)
ANSI C63.10: 2013

The above equipment has been tested by **Bureau Veritas Consumer Products Services (H.K.) Ltd., Taoyuan Branch**, and found compliance with the requirement of the above standards. The test record, data evaluation & Equipment Under Test (EUT) configurations represented herein are true and accurate accounts of the measurements of the sample's EMC characteristics under the conditions specified in this report.

Prepared by : Wendy Wu , **Date:** May 06, 2017
Wendy Wu / Specialist

Approved by : May Chen , **Date:** May 06, 2017
May Chen / Manager

2 Summary of Test Results

47 CFR FCC Part 15, Subpart E (Section 15.407)			
FCC Clause	Test Item	Result	Remarks
15.407(b)(6)	AC Power Conducted Emissions	Pass	Meet the requirement of limit. Minimum passing margin is -6.37dB at 0.50391MHz.
15.407(b) (1/2/3/4(i/ii)/6)	Radiated Emissions & Band Edge Measurement*	Pass	Meet the requirement of limit. Minimum passing margin is -0.1dB at 5725.00MHz, 10520.00MHz, 10600.00MHz.
15.407(a)(1/2/3)	Max Average Transmit Power	Pass	Meet the requirement of limit.
---	Occupied Bandwidth Measurement	-	Reference only.
15.407(a)(1/2/3)	Peak Power Spectral Density	Pass	Meet the requirement of limit.
15.407(g)	Frequency Stability	Pass	Meet the requirement of limit.
15.203	Antenna Requirement	Pass	No antenna connector is used

2.1 Measurement Uncertainty

Where relevant, the following measurement uncertainty levels have been estimated for tests performed on the EUT as specified in CISPR 16-4-2:

Measurement	Frequency	Expanded Uncertainty (k=2) (\pm)
Conducted Emissions at mains ports	150kHz ~ 30MHz	1.84 dB
Radiated Emissions up to 1 GHz	30MHz ~ 1GHz	5.30 dB
Radiated Emissions above 1 GHz	1GHz ~ 6GHz	4.78 dB
	6GHz ~ 18GHz	4.52 dB
	18GHz ~ 40GHz	5.08 dB

2.2 Modification Record

There were no modifications required for compliance.

3 General Information

3.1 General Description of EUT

Product	WiCS-2100
Brand	wePresent
Test Model	WiCS-2100
Status of EUT	ENGINEERING SAMPLE
Power Supply Rating	12Vdc from power adapter or 48Vdc from POE
Modulation Type	64QAM, 16QAM, QPSK, BPSK for OFDM 256QAM for OFDM in 11ac mode only
Modulation Technology	OFDM
Transfer Rate	802.11a: up to 54Mbps 802.11n: up to 300Mbps 802.11ac: up to 866.7Mbps
Operating Frequency	5.26 ~ 5.32GHz, 5.50 ~ 5.58GHz & 5.66 ~ 5.70GHz
Number of Channel	802.11a, 802.11n (HT20), 802.11ac (VHT20): 12 802.11n (HT40), 802.11ac (VHT40): 5 802.11ac (VHT80): 2
Output Power	5.26 ~ 5.32GHz: 89.441mW 5.50 ~ 5.58GHz & 5.66 ~ 5.70GHz: 84.732mW
Antenna Type	Refer to Note
Antenna Connector	Refer to Note
Accessory Device	Adapter x 1, USB dongle x 1
Data Cable Supplied	NA

Note:

- This report is prepared for FCC class II permissive change. The difference compared with the Report No.: RF170209C07-1 as the following:
 - ◆ Add DFS band <5.26 ~ 5.32GHz, 5.50 ~ 5.58GHz & 5.66 ~ 5.70GHz>
- According to above condition, all test items need to be performed. And all data were verified to meet the requirements.
- Simultaneously transmission condition.

Condition	Technology	
1	WLAN 2.4GHz	Bluetooth
2	WLAN 5GHz	Bluetooth

Note: The emission of the simultaneous operation has been evaluated and no non-compliance was found.

- The EUT must be supplied with a power adapter or POE as following table:

Adapter		
Brand	Model No.	Spec.
APD	WA-24Q12R	Input: 100-240Vac, 0.7A, 50-60Hz Output: 12V, 2A DC output cable(unshielded, 1.5m)
POE (only for test, ont for sale)		
Brand	Model No.	Spec.
PowerDsine	PD-3501G/AC	48Vdc

Note: From the above adapter and POE, the worst radiated test was found in **Adapter**. Therefore only the test data of the modes were recorded in this report.

5. The USB dongle is provided for the EUT as following table:

Brand	Model No.
wePresent	MH301

6. The antennas provided to the EUT, please refer to the following table:

For 2.4GHz & BT					
Antenna No.	Brand	Model	Antenna Net. Gain(dBi)	Frequency range (GHz)	Antenna Type
1 (Main-WLAN+BT combo Ant)	Pegatron Corp.	Pegatron P/N: 1415- 05VU000 (Hong-Bo P/N: 290- 30536)	2.85	2.4~2.4835	PCB
2 (Aux-WLAN Ant)			1.76	2.4~2.4835	
For 5GHz					
Antenna No.	Brand	Model	Antenna Net. Gain(dBi)	Frequency range (GHz)	Antenna Type
1 (Main-WLAN Ant)	Pegatron Corp.	Pegatron P/N: 1415- 05VU000 (Hong-Bo P/N: 290- 30536)	2.58	5.15~5.25	PCB
			3.37	5.25~5.35	
			3.68	5.47~5.725	
			3.58	5.725~5850	
2 (Aux-WLAN Ant)	Pegatron Corp.	Pegatron P/N: 1415-05VT000 (Hong-Bo P/N: 290- 30535)	2.76	5.15~5.25	PCB
			3.4	5.25~5.35	
			3.26	5.47~5.725	
			2.07	5.725~5850	

7. The EUT incorporates a MIMO function.

2.4GHz Band		
MODULATION MODE	DATA RATE (MCS)	TX & RX CONFIGURATION
802.11b	1 ~ 11Mbps	2TX 2RX
802.11g	6 ~ 54Mbps	2TX 2RX
802.11n (HT20)	MCS 0~7	2TX 2RX
	MCS 8~15	2TX 2RX
802.11n (HT40)	MCS 0~7	2TX 2RX
	MCS 8~15	2TX 2RX
5GHz Band		
MODULATION MODE	DATA RATE (MCS)	TX & RX CONFIGURATION
802.11a	6 ~ 54Mbps	2TX 2RX
802.11n (HT20)	MCS 0~7	2TX 2RX
	MCS 8~15	2TX 2RX
802.11n (HT40)	MCS 0~7	2TX 2RX
	MCS 8~15	2TX 2RX
802.11ac (VHT20)	MCS0~8 Nss=1	2TX 2RX
	MCS0~8 Nss=2	2TX 2RX
802.11ac (VHT40)	MCS0~9 Nss=1	2TX 2RX
	MCS0~9 Nss=2	2TX 2RX
802.11ac (VHT80)	MCS0~9 Nss=1	2TX 2RX
	MCS0~9 Nss=2	2TX 2RX

Note: The modulation and bandwidth are similar for 802.11n mode for 20MHz (40MHz) and 802.11ac mode for 20MHz (40MHz), therefore investigated worst case to representative mode in test report. (Final test mode refer section 3.2.1)

8. The above EUT information is declared by manufacturer and for more detailed features description, please refer to the manufacturer's specifications or user's manual.

3.2 Description of Test Modes

FOR 5260 ~ 5320MHz

4 channels are provided for 802.11a, 802.11n (HT20), 802.11ac (VHT20):

Channel	Frequency	Channel	Frequency
52	5260 MHz	60	5300 MHz
56	5280 MHz	64	5320 MHz

2 channels are provided for 802.11n (HT40), 802.11ac (VHT40):

Channel	Frequency	Channel	Frequency
54	5270 MHz	62	5310 MHz

1 channel is provided for 802.11ac (VHT80):

Channel	Frequency
58	5290 MHz

FOR 5500 ~ 5580 & 5660 ~ 5700MHz

8 channels are provided for 802.11a, 802.11n (HT20), 802.11ac (VHT20):

Channel	Frequency	Channel	Frequency
100	5500 MHz	116	5580 MHz
104	5520 MHz	132	5660 MHz
108	5540 MHz	136	5680 MHz
112	5560 MHz	140	5700 MHz

3 channels are provided for 802.11n (HT40), 802.11ac (VHT40):

Channel	Frequency	Channel	Frequency
102	5510 MHz	134	5670 MHz
110	5550 MHz		

1 channel is provided for 802.11ac (VHT80):

Channel	Frequency
106	5530 MHz

3.2.1 Test Mode Applicability and Tested Channel Detail

EUT Configure Mode	Applicable To				Description
	RE \geq 1G	RE<1G	PLC	APCM	
1	√	√	√	√	With adapter
2	-	-	√	-	With POE

Where **RE \geq 1G**: Radiated Emission above 1GHz **RE<1G**: Radiated Emission below 1GHz
PLC: Power Line Conducted Emission **APCM**: Antenna Port Conducted Measurement

NOTE:

1. The EUT had been pre-tested on the positioned of each 2 axis. The worst case was found when positioned on **X-plane**
2. "-" means no effect.

Radiated Emission Test (Above 1GHz):

- Pre-Scan has been conducted to determine the worst-case mode from all possible combinations between available modulations, data rates and antenna ports (if EUT with antenna diversity architecture).
- Following channel(s) was (were) selected for the final test as listed below.

Mode	FREQ. Band (MHz)	Available Channel	Tested Channel	Modulation Technology	Modulation Type	Data Rate (Mbps)
802.11a	5260-5320	52 to 64	52, 60, 64	OFDM	BPSK	6
802.11ac (VHT20)		52 to 64	52, 60, 64	OFDM	BPSK	6.5
802.11ac (VHT40)		54 to 62	54, 62	OFDM	BPSK	13.5
802.11ac (VHT80)		58	58	OFDM	BPSK	29.3
802.11a	5500-5580 5660-5700	100 to 140	100, 116, 140	OFDM	BPSK	6
802.11ac (VHT20)		100 to 140	100, 116, 140	OFDM	BPSK	6.5
802.11ac (VHT40)		102 to 134	102, 110, 134	OFDM	BPSK	13.5
802.11ac (VHT80)		106	106	OFDM	BPSK	29.3

Radiated Emission Test (Below 1GHz):

- Pre-Scan has been conducted to determine the worst-case mode from all possible combinations between available modulations, data rates and antenna ports (if EUT with antenna diversity architecture).
- Following channel(s) was (were) selected for the final test as listed below.

Mode	FREQ. Band (MHz)	Available Channel	Tested Channel	Modulation Technology	Modulation Type	Data Rate (Mbps)
802.11ac (VHT20)	5260-5320 5500-5580 5660-5700	52 to 64 100 to 140	60	OFDM	BPSK	6.5

Power Line Conducted Emission Test:

- Pre-Scan has been conducted to determine the worst-case mode from all possible combinations between available modulations, data rates and antenna ports (if EUT with antenna diversity architecture).
- Following channel(s) was (were) selected for the final test as listed below.

Mode	FREQ. Band (MHz)	Available Channel	Tested Channel	Modulation Technology	Modulation Type	Data Rate (Mbps)
802.11ac (VHT20)	5260-5320 5500-5580 5660-5700	52 to 64 100 to 140	60	OFDM	BPSK	6.5

Antenna Port Conducted Measurement:

- This item includes all test value of each mode, but only includes spectrum plot of worst value of each mode.
- Pre-Scan has been conducted to determine the worst-case mode from all possible combinations between available modulations, data rates and antenna ports (if EUT with antenna diversity architecture).
- Following channel(s) was (were) selected for the final test as listed below.

Mode	FREQ. Band (MHz)	Available Channel	Tested Channel	Modulation Technology	Modulation Type	Data Rate (Mbps)
802.11a	5260-5320	52 to 64	52, 60, 64	OFDM	BPSK	6
802.11ac (VHT20)		52 to 64	52, 60, 64	OFDM	BPSK	6.5
802.11ac (VHT40)		54 to 62	54, 62	OFDM	BPSK	13.5
802.11ac (VHT80)		58	58	OFDM	BPSK	29.3
802.11a	5500-5580 5660-5700	100 to 140	100, 116, 140	OFDM	BPSK	6
802.11ac (VHT20)		100 to 140	100, 116, 140	OFDM	BPSK	6.5
802.11ac (VHT40)		102 to 134	102, 110, 134	OFDM	BPSK	13.5
802.11ac (VHT80)		106	106	OFDM	BPSK	29.3

Test Condition:

Applicable To	Environmental Conditions	Input Power	Tested By
RE \geq 1G	23deg. C, 66%RH	120Vac, 60Hz	Weiwei Lo
RE $<$ 1G	23deg. C, 66%RH	120Vac, 60Hz	Terry Huang
PLC	25deg. C, 75%RH	120Vac, 60Hz	Andy Ho
APCM	25deg. C, 60%RH	120Vac, 60Hz	Anderson Chen

3.3 Duty Cycle of Test Signal

If duty cycle of test signal is $\geq 98\%$, duty factor is not required.
 If duty cycle of test signal is $< 98\%$, duty factor shall be considered.

802.11a: Duty cycle = $21.412 \text{ ms} / 21.537 \text{ ms} = 0.994$

802.11ac (VHT20): Duty cycle = $19.875 \text{ ms} / 19.994 \text{ ms} = 0.994$

802.11ac (VHT40): Duty cycle = $9.575 \text{ ms} / 9.7 \text{ ms} = 0.987$

802.11ac (VHT80): Duty cycle = $4.425 \text{ ms} / 4.52 \text{ ms} = 0.979$, Duty factor = $10 * \log(1/0.979) = 0.09$

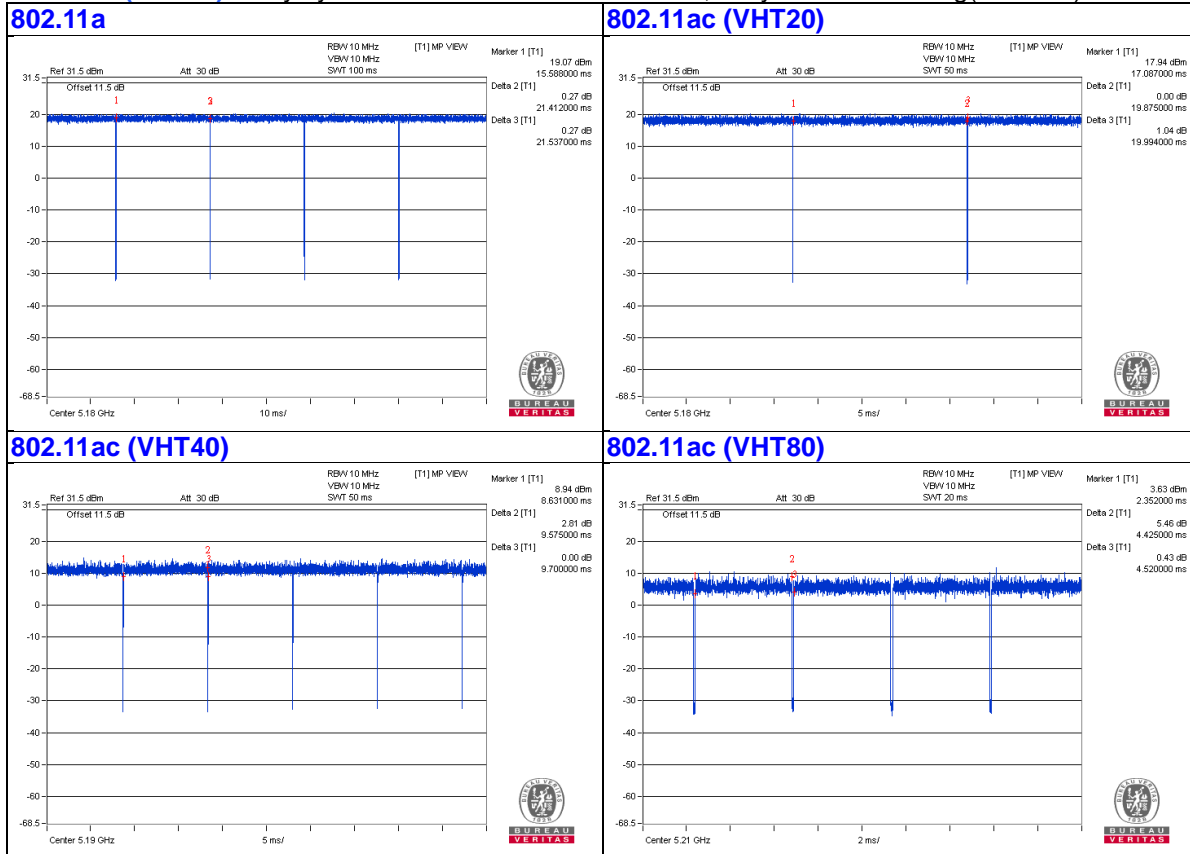

3.4 Description of Support Units

The EUT has been tested as an independent unit together with other necessary accessories or support units. The following support units or accessories were used to form a representative test configuration during the tests.

ID	Product	Brand	Model No.	Serial No.	FCC ID	Remarks
A.	Laptop	DELL	E5430	HYV4VY1	FCC DoC	Provided by Lab
B.	Monitor	ASUS	VS247	NA	NA	Provided by Lab
C.	PoE Adapter	PowerDsine	PD-3501G/AC	NA	NA	Provided by Lab
D.	Mouse	DELL	MS111-P	NA	NA	Provided by Lab

Note:

1. All power cords of the above support units are non-shielded (1.8m).

ID	Descriptions	Qty.	Length (m)	Shielding (Yes/No)	Cores (Qty.)	Remarks
1.	DC Cable	1	1.5	No	0	Supplied by client
2.	RJ-45 Cable	1	10	No	0	Provided by Lab
3.	Audio Cable	1	1.8	No	0	Provided by Lab
4.	HDMI Cable	1	3	Yes	0	Provided by Lab
5.	AC Cable	1	1.8	No	0	Provided by Lab
6.	RJ-45 Cable	1	3	No	0	Provided by Lab
7.	USB Cable	1	1.8	Yes	0	Provided by Lab

3.4.1 Configuration of System under Test

Mode 1:

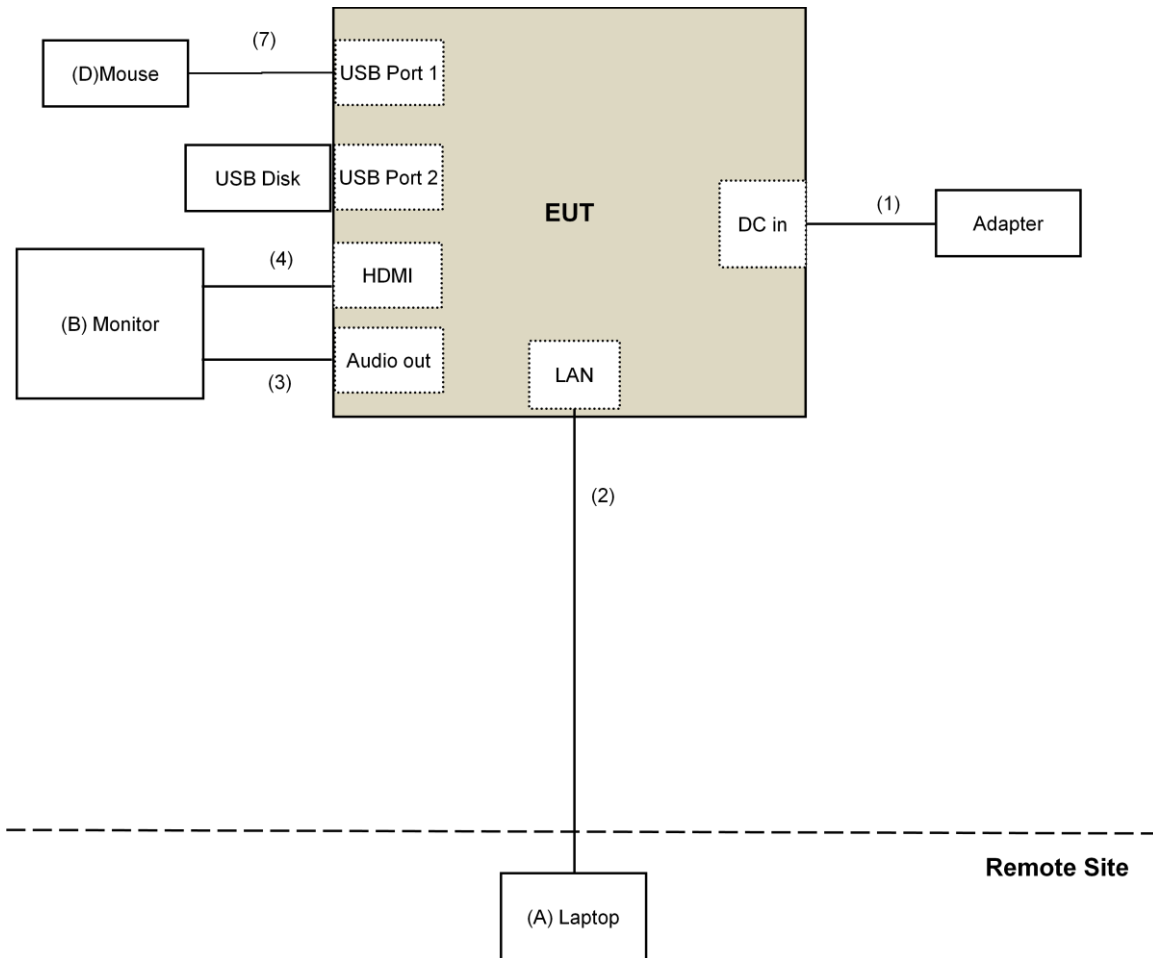

Mode 2:

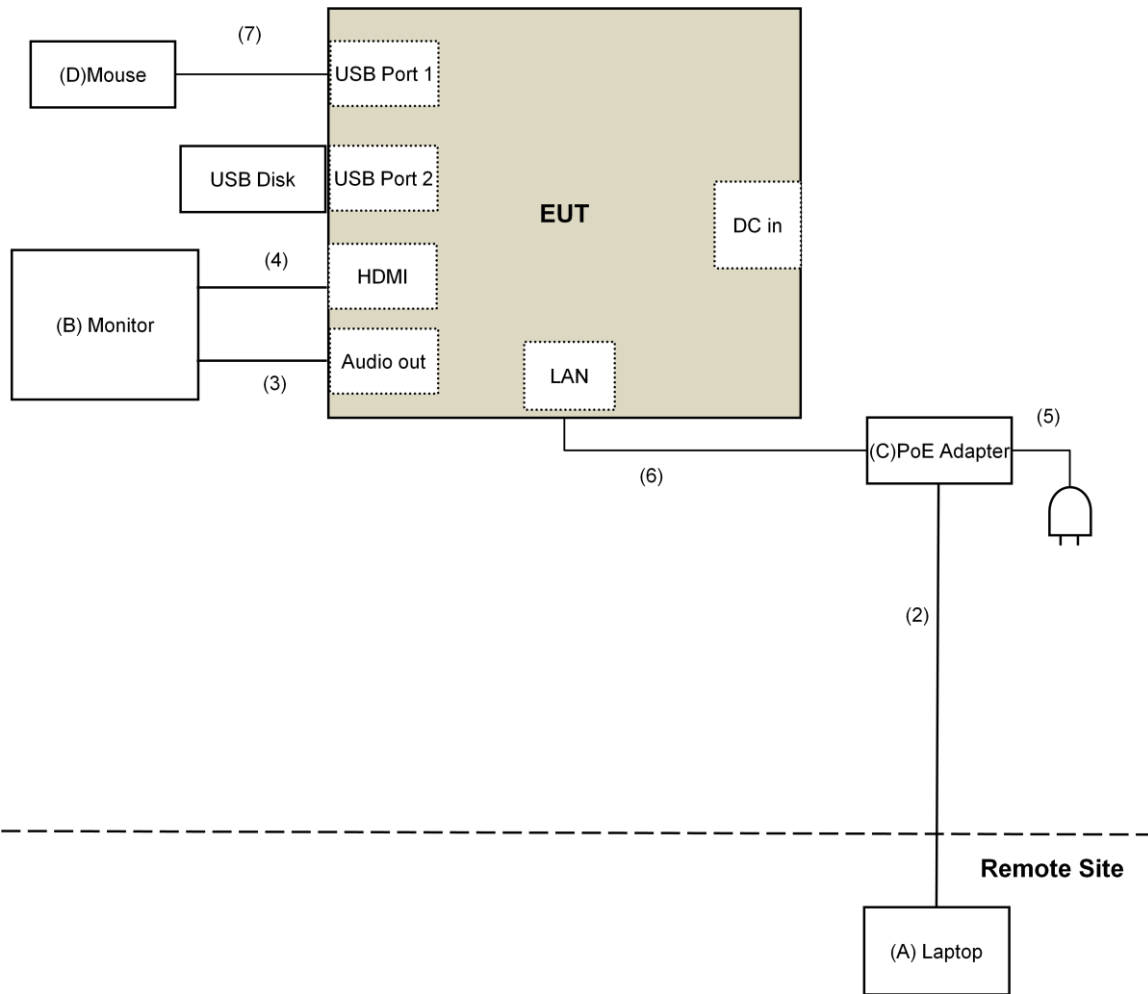

3.5 General Description of Applied Standard

The EUT is a RF Product. According to the specifications of the manufacturer, it must comply with the requirements of the following standards:

FCC Part 15, Subpart E (15.407)
KDB 789033 D02 General UNII Test Procedure New Rules v01r03
KDB 662911 D01 Multiple Transmitter Output v02r01
ANSI C63.10-2013

All test items have been performed and recorded as per the above standards.

NOTE: The EUT has been verified to comply with the requirements of FCC Part 15, Subpart B, Class B (DoC). The test report has been issued separately.

4 Test Types and Results

4.1 Radiated Emission and Bandedge Measurement

4.1.1 Limits of Radiated Emission and Bandedge Measurement

Radiated emissions which fall in the restricted bands must comply with the radiated emission limits specified as below table.

Frequencies (MHz)	Field Strength (microvolts/meter)	Measurement Distance (meters)
0.009 ~ 0.490	2400/F(kHz)	300
0.490 ~ 1.705	24000/F(kHz)	30
1.705 ~ 30.0	30	30
30 ~ 88	100	3
88 ~ 216	150	3
216 ~ 960	200	3
Above 960	500	3

NOTE:

1. The lower limit shall apply at the transition frequencies.
2. Emission level (dBuV/m) = 20 log Emission level (uV/m).
3. For frequencies above 1000MHz, the field strength limits are based on average detector, however, the peak field strength of any emission shall not exceed the maximum permitted average limits, specified above by more than 20dB under any condition of modulation.

Limits of unwanted emission out of the restricted bands

Applicable To		Limit	
789033 D02 General UNII Test Procedure New Rules v01r03		Field Strength at 3m	
		PK:74 (dBuV/m)	AV:54 (dBuV/m)
Frequency Band	Applicable To	EIRP Limit	Equivalent Field Strength at 3m
5150~5250 MHz	15.407(b)(1)	PK:-27 (dBm/MHz)	PK:68.2(dBuV/m)
5250~5350 MHz	15.407(b)(2)		
5470~5725 MHz	15.407(b)(3)		
5725~5850 MHz	<input type="checkbox"/> 15.407(b)(4)(i)	PK:-27 (dBm/MHz) ^{*1} PK:10 (dBm/MHz) ^{*2} PK:15.6 (dBm/MHz) ^{*3} PK:27 (dBm/MHz) ^{*4}	PK: 68.2(dBuV/m) ^{*1} PK:105.2 (dBuV/m) ^{*2} PK: 110.8(dBuV/m) ^{*3} PK:122.2 (dBuV/m) ^{*4}
	<input type="checkbox"/> 15.407(b)(4)(ii)	Emission limits in section 15.247(d)	
^{*1} beyond 75 MHz or more above of the band edge.		^{*2} below the band edge increasing linearly to 10 dBm/MHz at 25 MHz above.	
^{*3} below the band edge increasing linearly to a level of 15.6 dBm/MHz at 5 MHz above.		^{*4} from 5 MHz above or below the band edge increasing linearly to a level of 27 dBm/MHz at the band edge.	

Note:

The following formula is used to convert the equipment isotropic radiated power (eirp) to field strength:

$$E = \frac{1000000\sqrt{30P}}{3} \mu\text{V/m, where P is the eirp (Watts).}$$

4.1.2 Test Instruments

DESCRIPTION & MANUFACTURER	MODEL NO.	SERIAL NO.	CALIBRATED DATE	CALIBRATED UNTIL
Test Receiver Keysight	N9038A	MY54450088	July 20, 2016	July 19, 2017
Pre-Amplifier ^(*) EMCI	EMC001340	980142	Jan. 20, 2016	Jan. 19, 2018
Loop Antenna ^(*) Electro-Metrics	EM-6879	264	Dec. 16, 2016	Dec. 15, 2018
RF Cable	NA	LOOPCAB-001 LOOPCAB-002	Jan. 17, 2017	Jan. 16, 2018
Pre-Amplifier Mini-Circuits	ZFL-1000VH2B	AMP-ZFL-01	Nov. 10, 2016	Nov. 09, 2017
Trilog Broadband Antenna SCHWARZBECK	VULB 9168	9168-406	Dec. 13, 2016	Dec. 12, 2017
RF Cable	8D	966-4-1 966-4-2 966-4-3	Apr. 02, 2016	Apr. 01, 2017
Fixed attenuator Mini-Circuits	UNAT-5+	PAD-3m-4-01	Oct. 05, 2016	Oct. 04, 2017
Horn_Antenna SCHWARZBECK	BBHA 9120D	9120D-783	Dec. 27, 2016	Dec. 26, 2017
Pre-Amplifier EMCI	EMC12630SE	980385	Feb. 02, 2017	Feb. 01, 2018
RF Cable	EMC104-SM-SM-2000 EMC104-SM-SM-5000 EMC104-SM-SM-5000	160923 150318 150323	Feb. 02, 2017 Mar. 30, 2016 Mar. 30, 2016	Feb. 01, 2018 Mar. 29, 2017 Mar. 29, 2017
Pre-Amplifier EMCI	EMC184045SE	980387	Feb. 02, 2017	Feb. 01, 2018
Horn_Antenna SCHWARZBECK	BBHA 9170	BBHA9170608	Dec. 15, 2016	Dec. 14, 2017
RF Cable	SUCOFLEX 102	36432/2 36433/2	Jan. 15, 2017	Jan. 14, 2018
Software	ADT_Radiated_V8.7.08	NA	NA	NA
Antenna Tower & Turn Table Max-Full	MF-7802	MF780208410	NA	NA
Boresight Antenna Fixture	FBA-01	FBA-SIP02	NA	NA
Spectrum Analyzer R&S	FSV40	100964	June 28, 2016	June 27, 2017
Power meter Anritsu	ML2495A	1014008	May 5, 2016	May 4, 2017
Power sensor Anritsu	MA2411B	0917122	May 5, 2016	May 4, 2017
AC Power Source Extech Electronics	6205	1440452	NA	NA
Temperature & Humidity Chamber Giant Force	GTH-150-40-SP-AR	MAA0812-008	Jan. 11, 2017	Jan. 10, 2018
Digital Multimeter FLUKE	87III	73680266	Nov. 10, 2016	Nov. 09, 2017

Note:

1. The calibration interval of the above test instruments is 12 months and the calibrations are traceable to NML/ROC and NIST/USA.
2. *The calibration interval of the above test instruments is 24 months and the calibrations are traceable to NML/ROC and NIST/USA.
3. The test was performed in 966 Chamber No. 4.
4. The FCC Site Registration No. is 292998
5. The CANADA Site Registration No. is 20331-2
- 6 Loop antenna was used for all emissions below 30 MHz.
7. Tested Date: Mar. 08 to 09, 2017

4.1.3 Test Procedure

For Radiated emission below 30MHz

- a. The EUT was placed on the top of a rotating table 0.8 meters above the ground at a 3 meter chamber room. The table was rotated 360 degrees to determine the position of the highest radiation.
- b. The EUT was set 3 meters away from the interference-receiving antenna, which was mounted on the top of a variable-height antenna tower.
- c. Both X and Y axes of the antenna are set to make the measurement.
- d. For each suspected emission, the EUT was arranged to its worst case and the rotatable table was turned from 0 degrees to 360 degrees to find the maximum reading.
- e. The test-receiver system was set to Quasi-Peak Detect Function and Specified Bandwidth with Maximum Hold Mode.

NOTE:

1. The resolution bandwidth and video bandwidth of test receiver/spectrum analyzer is 9kHz at frequency below 30MHz.

For Radiated emission above 30MHz

- a. The EUT was placed on the top of a rotating table 0.8 meters (for 30MHz ~ 1GHz) / 1.5 meters (for above 1GHz) above the ground at 3 meter chamber room for test. The table was rotated 360 degrees to determine the position of the highest radiation.
- b. The EUT was set 3 meters away from the interference-receiving antenna, which was mounted on the top of a variable-height antenna tower.
- c. The height of antenna is varied from one meter to four meters above the ground to determine the maximum value of the field strength. Both horizontal and vertical polarizations of the antenna are set to make the measurement.
- d. For each suspected emission, the EUT was arranged to its worst case and then the antenna was tuned to heights from 1 meter to 4 meters and the rotatable table was turned from 0 degrees to 360 degrees to find the maximum reading.
- e. The test-receiver system was set to quasi-peak detect function and specified bandwidth with maximum hold mode when the test frequency is below 1 GHz.
- f. The test-receiver system was set to peak and average detect function and specified bandwidth with maximum hold mode when the test frequency is above 1 GHz. If the peak reading value also meets average limit, measurement with the average detector is unnecessary.

Note:

1. The resolution bandwidth and video bandwidth of test receiver/spectrum analyzer is 120kHz for Quasi-peak detection (QP) at frequency below 1GHz.
2. The resolution bandwidth of test receiver/spectrum analyzer is 1 MHz and the video bandwidth is 3 MHz for Peak detection (PK) at frequency above 1GHz.
3. The resolution bandwidth of test receiver/spectrum analyzer is 1MHz and the video bandwidth is $\geq 1/T$ (Duty cycle < 98%) or 10Hz (Duty cycle $\geq 98\%$) for Average detection (AV) at frequency above 1GHz.
4. All modes of operation were investigated and the worst-case emissions are reported.

4.1.4 Deviation from Test Standard

No deviation.

4.1.5 Test Setup

For Radiated emission below 30MHz

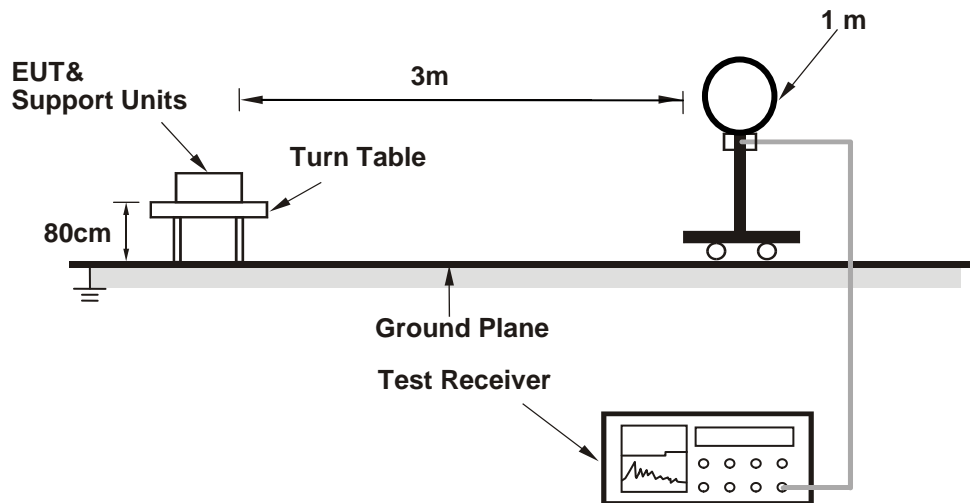

For Radiated emission 30MHz to 1GHz

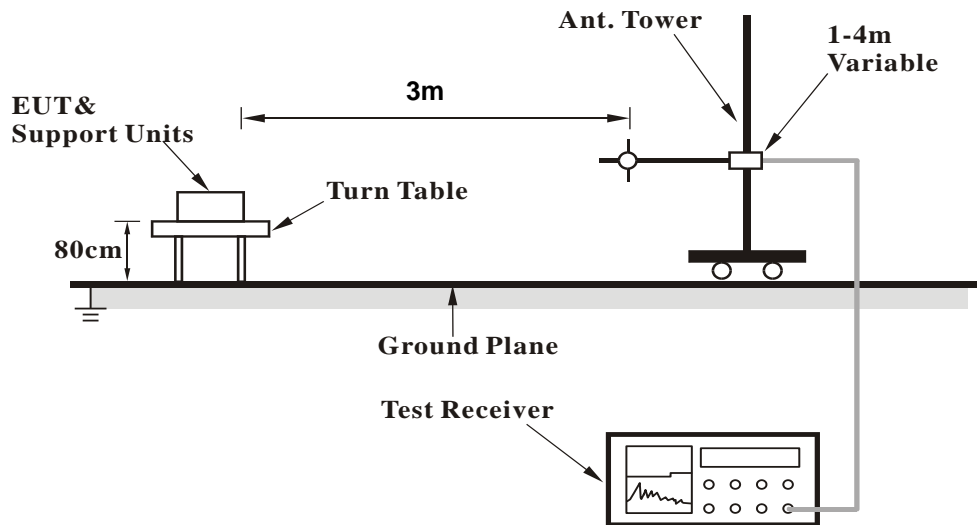

For Radiated emission above 1GHz

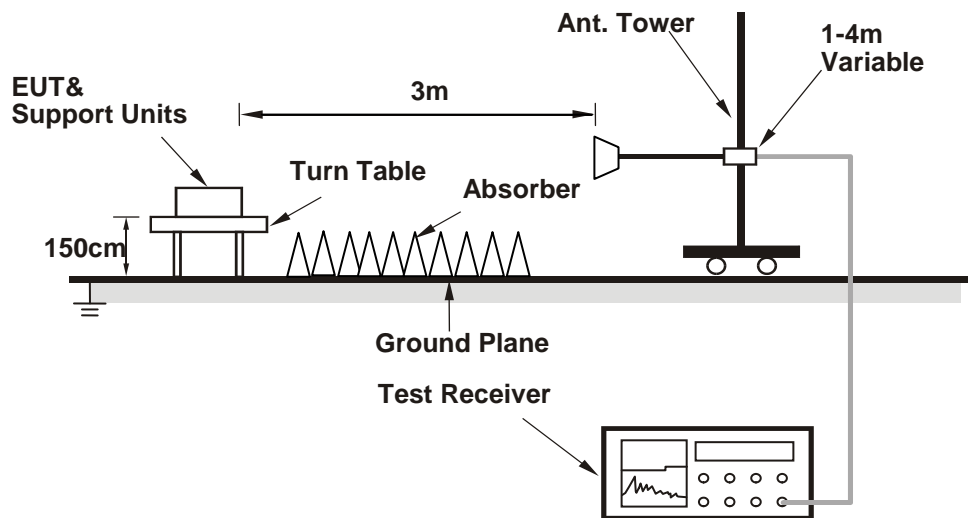

For the actual test configuration, please refer to the attached file (Test Setup Photo).

4.1.6 EUT Operating Condition

- a. Connected the EUT with the Laptop which is placed on remote site.
- b. Controlling software (QRCT.EXE v3.0.197.0) has been activated to set the EUT on specific status.

4.1.7 Test Results

Above 1GHz Data:

802.11a

CHANNEL	TX Channel 52	DETECTOR FUNCTION	Peak (PK)
FREQUENCY RANGE	1GHz ~ 40GHz		Average (AV)

ANTENNA POLARITY & TEST DISTANCE: HORIZONTAL AT 3 M

NO.	FREQ. (MHz)	EMISSION LEVEL (dBuV/m)	LIMIT (dBuV/m)	MARGIN (dB)	ANTENNA HEIGHT (m)	TABLE ANGLE (Degree)	RAW VALUE (dBuV)	CORRECTION FACTOR (dB/m)
1	5150.00	49.7 PK	74.0	-24.3	1.53 H	300	46.8	2.9
2	5150.00	37.0 AV	54.0	-17.0	1.53 H	300	34.1	2.9
3	*5260.00	110.9 PK			1.53 H	300	107.7	3.2
4	*5260.00	100.1 AV			1.53 H	300	96.9	3.2
5	5350.00	61.0 PK	74.0	-13.0	1.53 H	300	57.6	3.4
6	5350.00	38.8 AV	54.0	-15.2	1.53 H	300	35.4	3.4
7	#10520.00	58.7 PK	74.0	-15.3	1.34 H	137	46.4	12.3
8	#10520.00	47.9 AV	54.0	-6.1	1.34 H	137	35.6	12.3
9	15780.00	51.1 PK	74.0	-22.9	1.06 H	83	38.1	13.0
10	15780.00	39.8 AV	54.0	-14.2	1.06 H	83	26.8	13.0

ANTENNA POLARITY & TEST DISTANCE: VERTICAL AT 3 M

NO.	FREQ. (MHz)	EMISSION LEVEL (dBuV/m)	LIMIT (dBuV/m)	MARGIN (dB)	ANTENNA HEIGHT (m)	TABLE ANGLE (Degree)	RAW VALUE (dBuV)	CORRECTION FACTOR (dB/m)
1	5150.00	52.5 PK	74.0	-21.5	1.15 V	305	49.6	2.9
2	5150.00	39.6 AV	54.0	-14.4	1.15 V	305	36.7	2.9
3	*5260.00	114.7 PK			1.15 V	305	111.5	3.2
4	*5260.00	104.3 AV			1.15 V	305	101.1	3.2
5	5350.00	64.0 PK	74.0	-10.0	1.15 V	305	60.6	3.4
6	5350.00	40.6 AV	54.0	-13.4	1.15 V	305	37.2	3.4
7	#10520.00	67.7 PK	74.0	-6.3	1.00 V	172	55.4	12.3
8	#10520.00	53.9 AV	54.0	-0.1	1.00 V	172	41.6	12.3
9	15780.00	53.1 PK	74.0	-20.9	1.36 V	109	40.1	13.0
10	15780.00	41.3 AV	54.0	-12.7	1.36 V	109	28.3	13.0

REMARKS:

1. Emission Level(dBuV/m) = Raw Value(dBuV) + Correction Factor(dB/m)
2. Correction Factor(dB/m) = Antenna Factor(dB/m) + Cable Factor(dB) – Pre-Amplifier Factor(dB)
3. The other emission levels were very low against the limit.
4. Margin value = Emission Level – Limit value
5. " * ": Fundamental frequency.
6. " # ": The radiated frequency is out of the restricted band.

CHANNEL	TX Channel 60	DETECTOR FUNCTION	Peak (PK)
FREQUENCY RANGE	1GHz ~ 40GHz		Average (AV)

ANTENNA POLARITY & TEST DISTANCE: HORIZONTAL AT 3 M

NO.	FREQ. (MHz)	EMISSION LEVEL (dBuV/m)	LIMIT (dBuV/m)	MARGIN (dB)	ANTENNA HEIGHT (m)	TABLE ANGLE (Degree)	RAW VALUE (dBuV)	CORRECTION FACTOR (dB/m)
1	*5300.00	108.2 PK			1.55 H	301	105.0	3.2
2	*5300.00	98.3 AV			1.55 H	301	95.1	3.2
3	5350.00	57.1 PK	74.0	-16.9	1.55 H	301	53.7	3.4
4	5350.00	42.8 AV	54.0	-11.2	1.55 H	301	39.4	3.4
5	10600.00	58.2 PK	74.0	-15.8	1.34 H	152	45.7	12.5
6	10600.00	47.4 AV	54.0	-6.6	1.34 H	152	34.9	12.5
7	15900.00	51.0 PK	74.0	-23.0	1.04 H	76	38.6	12.4
8	15900.00	39.3 AV	54.0	-14.7	1.04 H	76	26.9	12.4

ANTENNA POLARITY & TEST DISTANCE: VERTICAL AT 3 M

NO.	FREQ. (MHz)	EMISSION LEVEL (dBuV/m)	LIMIT (dBuV/m)	MARGIN (dB)	ANTENNA HEIGHT (m)	TABLE ANGLE (Degree)	RAW VALUE (dBuV)	CORRECTION FACTOR (dB/m)
1	*5300.00	112.1 PK			1.13 V	304	108.9	3.2
2	*5300.00	102.4 AV			1.13 V	304	99.2	3.2
3	5350.00	60.2 PK	74.0	-13.8	1.13 V	304	56.8	3.4
4	5350.00	44.6 AV	54.0	-9.4	1.13 V	304	41.2	3.4
5	10600.00	67.1 PK	74.0	-6.9	1.00 V	173	54.6	12.5
6	10600.00	53.9 AV	54.0	-0.1	1.00 V	173	41.4	12.5
7	15900.00	53.0 PK	74.0	-21.0	1.33 V	97	40.6	12.4
8	15900.00	41.5 AV	54.0	-12.5	1.33 V	97	29.1	12.4

REMARKS:

1. Emission Level(dBuV/m) = Raw Value(dBuV) + Correction Factor(dB/m)
2. Correction Factor(dB/m) = Antenna Factor(dB/m) + Cable Factor(dB) – Pre-Amplifier Factor(dB)
3. The other emission levels were very low against the limit.
4. Margin value = Emission Level – Limit value
5. " * ": Fundamental frequency.

CHANNEL	TX Channel 64	DETECTOR FUNCTION	Peak (PK)
FREQUENCY RANGE	1GHz ~ 40GHz		Average (AV)

ANTENNA POLARITY & TEST DISTANCE: HORIZONTAL AT 3 M

NO.	FREQ. (MHz)	EMISSION LEVEL (dBuV/m)	LIMIT (dBuV/m)	MARGIN (dB)	ANTENNA HEIGHT (m)	TABLE ANGLE (Degree)	RAW VALUE (dBuV)	CORRECTION FACTOR (dB/m)
1	*5320.00	104.9 PK			1.00 H	299	101.7	3.2
2	*5320.00	95.3 AV			1.00 H	299	92.1	3.2
3	5350.00	61.0 PK	74.0	-13.0	1.00 H	299	57.6	3.4
4	5350.00	48.3 AV	54.0	-5.7	1.00 H	299	44.9	3.4
5	10640.00	58.7 PK	74.0	-15.3	1.35 H	153	46.1	12.6
6	10640.00	47.8 AV	54.0	-6.2	1.35 H	153	35.2	12.6
7	15960.00	51.3 PK	74.0	-22.7	1.00 H	91	38.9	12.4
8	15960.00	39.5 AV	54.0	-14.5	1.00 H	91	27.1	12.4

ANTENNA POLARITY & TEST DISTANCE: VERTICAL AT 3 M

NO.	FREQ. (MHz)	EMISSION LEVEL (dBuV/m)	LIMIT (dBuV/m)	MARGIN (dB)	ANTENNA HEIGHT (m)	TABLE ANGLE (Degree)	RAW VALUE (dBuV)	CORRECTION FACTOR (dB/m)
1	*5320.00	112.0 PK			1.12 V	301	108.8	3.2
2	*5320.00	102.5 AV			1.12 V	301	99.3	3.2
3	5350.00	65.1 PK	74.0	-8.9	1.12 V	301	61.7	3.4
4	5350.00	53.8 AV	54.0	-0.2	1.12 V	301	50.4	3.4
5	10640.00	67.5 PK	74.0	-6.5	1.00 V	173	54.9	12.6
6	10640.00	53.6 AV	54.0	-0.4	1.00 V	173	41.0	12.6
7	15960.00	53.3 PK	74.0	-20.7	1.31 V	104	40.9	12.4
8	15960.00	41.6 AV	54.0	-12.4	1.31 V	104	29.2	12.4

REMARKS:

1. Emission Level(dBuV/m) = Raw Value(dBuV) + Correction Factor(dB/m)
2. Correction Factor(dB/m) = Antenna Factor(dB/m) + Cable Factor(dB) – Pre-Amplifier Factor(dB)
3. The other emission levels were very low against the limit.
4. Margin value = Emission Level – Limit value
5. " * ": Fundamental frequency.

CHANNEL	TX Channel 100	DETECTOR FUNCTION	Peak (PK)
FREQUENCY RANGE	1GHz ~ 40GHz		Average (AV)

ANTENNA POLARITY & TEST DISTANCE: HORIZONTAL AT 3 M

NO.	FREQ. (MHz)	EMISSION LEVEL (dBuV/m)	LIMIT (dBuV/m)	MARGIN (dB)	ANTENNA HEIGHT (m)	TABLE ANGLE (Degree)	RAW VALUE (dBuV)	CORRECTION FACTOR (dB/m)
1	#5470.00	63.6 PK	74.0	-10.4	1.05 H	285	60.1	3.5
2	#5470.00	48.4 AV	54.0	-5.6	1.05 H	285	44.9	3.5
3	*5500.00	102.5 PK			1.05 H	285	99.0	3.5
4	*5500.00	92.7 AV			1.05 H	285	89.2	3.5
5	11000.00	58.4 PK	74.0	-15.6	1.36 H	152	45.0	13.4
6	11000.00	47.4 AV	54.0	-6.6	1.36 H	152	34.0	13.4
7	#16500.00	48.6 PK	74.0	-25.4	1.00 H	76	34.1	14.5
8	#16500.00	37.0 AV	54.0	-17.0	1.00 H	76	22.5	14.5

ANTENNA POLARITY & TEST DISTANCE: VERTICAL AT 3 M

NO.	FREQ. (MHz)	EMISSION LEVEL (dBuV/m)	LIMIT (dBuV/m)	MARGIN (dB)	ANTENNA HEIGHT (m)	TABLE ANGLE (Degree)	RAW VALUE (dBuV)	CORRECTION FACTOR (dB/m)
1	#5470.00	67.8 PK	74.0	-6.2	1.00 V	308	64.3	3.5
2	#5470.00	53.7 AV	54.0	-0.3	1.00 V	308	50.2	3.5
3	*5500.00	109.3 PK			1.00 V	308	105.8	3.5
4	*5500.00	99.8 AV			1.00 V	308	96.3	3.5
5	11000.00	67.3 PK	74.0	-6.7	1.00 V	182	53.9	13.4
6	11000.00	52.4 AV	54.0	-1.6	1.00 V	182	39.0	13.4
7	#16500.00	49.3 PK	74.0	-24.7	1.40 V	87	34.8	14.5
8	#16500.00	37.8 AV	54.0	-16.2	1.40 V	87	23.3	14.5

REMARKS:

1. Emission Level(dBuV/m) = Raw Value(dBuV) + Correction Factor(dB/m)
2. Correction Factor(dB/m) = Antenna Factor(dB/m) + Cable Factor(dB) – Pre-Amplifier Factor(dB)
3. The other emission levels were very low against the limit.
4. Margin value = Emission Level – Limit value
5. " * ": Fundamental frequency.
6. " # ": The radiated frequency is out of the restricted band.

CHANNEL	TX Channel 116	DETECTOR FUNCTION	Peak (PK)
FREQUENCY RANGE	1GHz ~ 40GHz		Average (AV)

ANTENNA POLARITY & TEST DISTANCE: HORIZONTAL AT 3 M

NO.	FREQ. (MHz)	EMISSION LEVEL (dBuV/m)	LIMIT (dBuV/m)	MARGIN (dB)	ANTENNA HEIGHT (m)	TABLE ANGLE (Degree)	RAW VALUE (dBuV)	CORRECTION FACTOR (dB/m)
1	*5580.00	106.2 PK			1.07 H	289	102.6	3.6
2	*5580.00	95.2 AV			1.07 H	289	91.6	3.6
3	11160.00	59.1 PK	74.0	-14.9	1.30 H	148	46.2	12.9
4	11160.00	47.8 AV	54.0	-6.2	1.30 H	148	34.9	12.9
5	#16740.00	48.1 PK	74.0	-25.9	1.00 H	63	32.5	15.6
6	#16740.00	36.8 AV	54.0	-17.2	1.00 H	63	21.2	15.6

ANTENNA POLARITY & TEST DISTANCE: VERTICAL AT 3 M

NO.	FREQ. (MHz)	EMISSION LEVEL (dBuV/m)	LIMIT (dBuV/m)	MARGIN (dB)	ANTENNA HEIGHT (m)	TABLE ANGLE (Degree)	RAW VALUE (dBuV)	CORRECTION FACTOR (dB/m)
1	*5580.00	113.4 PK			1.00 V	305	109.8	3.6
2	*5580.00	102.5 AV			1.00 V	305	98.9	3.6
3	11160.00	67.3 PK	74.0	-6.7	1.00 V	185	54.4	12.9
4	11160.00	53.3 AV	54.0	-0.7	1.00 V	185	40.4	12.9
5	#16740.00	49.4 PK	74.0	-24.6	1.40 V	77	33.8	15.6
6	#16740.00	37.8 AV	54.0	-16.2	1.40 V	77	22.2	15.6

REMARKS:

1. Emission Level(dBuV/m) = Raw Value(dBuV) + Correction Factor(dB/m)
2. Correction Factor(dB/m) = Antenna Factor(dB/m) + Cable Factor(dB) – Pre-Amplifier Factor(dB)
3. The other emission levels were very low against the limit.
4. Margin value = Emission Level – Limit value
5. " * ": Fundamental frequency.
6. " # ": The radiated frequency is out of the restricted band.

CHANNEL	TX Channel 140	DETECTOR FUNCTION	Peak (PK)
FREQUENCY RANGE	1GHz ~ 40GHz		Average (AV)

ANTENNA POLARITY & TEST DISTANCE: HORIZONTAL AT 3 M

NO.	FREQ. (MHz)	EMISSION LEVEL (dBuV/m)	LIMIT (dBuV/m)	MARGIN (dB)	ANTENNA HEIGHT (m)	TABLE ANGLE (Degree)	RAW VALUE (dBuV)	CORRECTION FACTOR (dB/m)
1	*5700.00	102.4 PK			1.02 H	286	98.5	3.9
2	*5700.00	92.9 AV			1.02 H	286	89.0	3.9
3	#5725.00	63.9 PK	74.0	-10.1	1.02 H	286	59.9	4.0
4	#5725.00	48.4 AV	54.0	-5.6	1.02 H	286	44.4	4.0
5	11400.00	59.6 PK	74.0	-14.4	1.25 H	147	46.6	13.0
6	11400.00	48.1 AV	54.0	-5.9	1.25 H	147	35.1	13.0
7	#17100.00	48.4 PK	74.0	-25.6	1.00 H	58	31.0	17.4
8	#17100.00	37.0 AV	54.0	-17.0	1.00 H	58	19.6	17.4

ANTENNA POLARITY & TEST DISTANCE: VERTICAL AT 3 M

NO.	FREQ. (MHz)	EMISSION LEVEL (dBuV/m)	LIMIT (dBuV/m)	MARGIN (dB)	ANTENNA HEIGHT (m)	TABLE ANGLE (Degree)	RAW VALUE (dBuV)	CORRECTION FACTOR (dB/m)
1	*5700.00	109.6 PK			1.15 V	306	105.7	3.9
2	*5700.00	99.8 AV			1.15 V	306	95.9	3.9
3	#5725.00	71.3 PK	74.0	-2.7	1.15 V	306	67.3	4.0
4	#5725.00	53.6 AV	54.0	-0.4	1.15 V	306	49.6	4.0
5	11400.00	67.0 PK	74.0	-7.0	1.00 V	213	54.0	13.0
6	11400.00	51.4 AV	54.0	-2.6	1.00 V	213	38.4	13.0
7	#17100.00	50.0 PK	74.0	-24.0	1.42 V	84	32.6	17.4
8	#17100.00	38.2 AV	54.0	-15.8	1.42 V	84	20.8	17.4

REMARKS:

1. Emission Level(dBuV/m) = Raw Value(dBuV) + Correction Factor(dB/m)
2. Correction Factor(dB/m) = Antenna Factor(dB/m) + Cable Factor(dB) – Pre-Amplifier Factor(dB)
3. The other emission levels were very low against the limit.
4. Margin value = Emission Level – Limit value
5. " * ": Fundamental frequency.
6. " # ": The radiated frequency is out of the restricted band.

802.11ac (VHT20)

CHANNEL	TX Channel 52	DETECTOR FUNCTION	Peak (PK)
FREQUENCY RANGE	1GHz ~ 40GHz		Average (AV)

ANTENNA POLARITY & TEST DISTANCE: HORIZONTAL AT 3 M

NO.	FREQ. (MHz)	EMISSION LEVEL (dBuV/m)	LIMIT (dBuV/m)	MARGIN (dB)	ANTENNA HEIGHT (m)	TABLE ANGLE (Degree)	RAW VALUE (dBuV)	CORRECTION FACTOR (dB/m)
1	5150.00	48.0 PK	74.0	-26.0	1.59 H	303	45.1	2.9
2	5150.00	36.1 AV	54.0	-17.9	1.59 H	303	33.2	2.9
3	*5260.00	113.5 PK			1.59 H	303	110.3	3.2
4	*5260.00	102.3 AV			1.59 H	303	99.1	3.2
5	5350.00	51.4 PK	74.0	-22.6	1.59 H	303	48.0	3.4
6	5350.00	41.2 AV	54.0	-12.8	1.59 H	303	37.8	3.4
7	#10520.00	59.0 PK	74.0	-15.0	1.35 H	163	46.7	12.3
8	#10520.00	47.5 AV	54.0	-6.5	1.35 H	163	35.2	12.3
9	15780.00	48.4 PK	74.0	-25.6	1.00 H	70	35.4	13.0
10	15780.00	36.8 AV	54.0	-17.2	1.00 H	70	23.8	13.0

ANTENNA POLARITY & TEST DISTANCE: VERTICAL AT 3 M

NO.	FREQ. (MHz)	EMISSION LEVEL (dBuV/m)	LIMIT (dBuV/m)	MARGIN (dB)	ANTENNA HEIGHT (m)	TABLE ANGLE (Degree)	RAW VALUE (dBuV)	CORRECTION FACTOR (dB/m)
1	5150.00	51.0 PK	74.0	-23.0	1.18 V	303	48.1	2.9
2	5150.00	38.7 AV	54.0	-15.3	1.18 V	303	35.8	2.9
3	*5260.00	117.4 PK			1.18 V	303	114.2	3.2
4	*5260.00	106.9 AV			1.18 V	303	103.7	3.2
5	5350.00	54.3 PK	74.0	-19.7	1.18 V	303	50.9	3.4
6	5350.00	43.0 AV	54.0	-11.0	1.18 V	303	39.6	3.4
7	#10520.00	67.8 PK	74.0	-6.2	1.03 V	171	55.5	12.3
8	#10520.00	53.3 AV	54.0	-0.7	1.03 V	171	41.0	12.3
9	15780.00	50.3 PK	74.0	-23.7	1.36 V	93	37.3	13.0
10	15780.00	39.2 AV	54.0	-14.8	1.36 V	93	26.2	13.0

REMARKS:

- Emission Level(dBuV/m) = Raw Value(dBuV) + Correction Factor(dB/m)
- Correction Factor(dB/m) = Antenna Factor(dB/m) + Cable Factor(dB) – Pre-Amplifier Factor(dB)
- The other emission levels were very low against the limit.
- Margin value = Emission Level – Limit value
- " * ": Fundamental frequency.
- " # ": The radiated frequency is out of the restricted band.

CHANNEL	TX Channel 60	DETECTOR FUNCTION	Peak (PK)
FREQUENCY RANGE	1GHz ~ 40GHz		Average (AV)

ANTENNA POLARITY & TEST DISTANCE: HORIZONTAL AT 3 M

NO.	FREQ. (MHz)	EMISSION LEVEL (dBuV/m)	LIMIT (dBuV/m)	MARGIN (dB)	ANTENNA HEIGHT (m)	TABLE ANGLE (Degree)	RAW VALUE (dBuV)	CORRECTION FACTOR (dB/m)
1	*5300.00	111.2 PK			1.54 H	299	108.0	3.2
2	*5300.00	100.2 AV			1.54 H	299	97.0	3.2
3	5350.00	61.5 PK	74.0	-12.5	1.54 H	299	58.1	3.4
4	5350.00	51.1 AV	54.0	-2.9	1.54 H	299	47.7	3.4
5	10600.00	58.6 PK	74.0	-15.4	1.33 H	146	46.1	12.5
6	10600.00	47.4 AV	54.0	-6.6	1.33 H	146	34.9	12.5
7	15900.00	48.1 PK	74.0	-25.9	1.00 H	69	35.7	12.4
8	15900.00	36.6 AV	54.0	-17.4	1.00 H	69	24.2	12.4

ANTENNA POLARITY & TEST DISTANCE: VERTICAL AT 3 M

NO.	FREQ. (MHz)	EMISSION LEVEL (dBuV/m)	LIMIT (dBuV/m)	MARGIN (dB)	ANTENNA HEIGHT (m)	TABLE ANGLE (Degree)	RAW VALUE (dBuV)	CORRECTION FACTOR (dB/m)
1	*5300.00	115.0 PK			1.00 V	304	111.8	3.2
2	*5300.00	104.5 AV			1.00 V	304	101.3	3.2
3	5350.00	64.4 PK	74.0	-9.6	1.00 V	304	61.0	3.4
4	5350.00	53.0 AV	54.0	-1.0	1.00 V	304	49.6	3.4
5	10600.00	67.6 PK	74.0	-6.4	1.16 V	171	55.1	12.5
6	10600.00	53.9 AV	54.0	-0.1	1.16 V	171	41.4	12.5
7	15900.00	53.2 PK	74.0	-20.8	1.29 V	90	40.8	12.4
8	15900.00	41.7 AV	54.0	-12.3	1.29 V	90	29.3	12.4

REMARKS:

1. Emission Level(dBuV/m) = Raw Value(dBuV) + Correction Factor(dB/m)
2. Correction Factor(dB/m) = Antenna Factor(dB/m) + Cable Factor(dB) – Pre-Amplifier Factor(dB)
3. The other emission levels were very low against the limit.
4. Margin value = Emission Level – Limit value
5. " * ": Fundamental frequency.

CHANNEL	TX Channel 64	DETECTOR FUNCTION	Peak (PK)
FREQUENCY RANGE	1GHz ~ 40GHz		Average (AV)

ANTENNA POLARITY & TEST DISTANCE: HORIZONTAL AT 3 M

NO.	FREQ. (MHz)	EMISSION LEVEL (dBuV/m)	LIMIT (dBuV/m)	MARGIN (dB)	ANTENNA HEIGHT (m)	TABLE ANGLE (Degree)	RAW VALUE (dBuV)	CORRECTION FACTOR (dB/m)
1	*5320.00	107.3 PK			1.49 H	302	104.1	3.2
2	*5320.00	98.1 AV			1.49 H	302	94.9	3.2
3	5350.00	63.5 PK	74.0	-10.5	1.49 H	302	60.1	3.4
4	5350.00	51.4 AV	54.0	-2.6	1.49 H	302	48.0	3.4
5	10640.00	58.8 PK	74.0	-15.2	1.36 H	151	46.2	12.6
6	10640.00	47.5 AV	54.0	-6.5	1.36 H	151	34.9	12.6
7	15960.00	48.0 PK	74.0	-26.0	1.00 H	54	35.6	12.4
8	15960.00	36.5 AV	54.0	-17.5	1.00 H	54	24.1	12.4

ANTENNA POLARITY & TEST DISTANCE: VERTICAL AT 3 M

NO.	FREQ. (MHz)	EMISSION LEVEL (dBuV/m)	LIMIT (dBuV/m)	MARGIN (dB)	ANTENNA HEIGHT (m)	TABLE ANGLE (Degree)	RAW VALUE (dBuV)	CORRECTION FACTOR (dB/m)
1	*5320.00	111.2 PK			1.04 V	302	108.0	3.2
2	*5320.00	102.2 AV			1.04 V	302	99.0	3.2
3	5350.00	66.7 PK	74.0	-7.3	1.04 V	302	63.3	3.4
4	5350.00	53.8 AV	54.0	-0.2	1.04 V	302	50.4	3.4
5	10640.00	67.3 PK	74.0	-6.7	1.04 V	172	54.7	12.6
6	10640.00	53.6 AV	54.0	-0.4	1.04 V	172	41.0	12.6
7	15960.00	53.3 PK	74.0	-20.7	1.30 V	100	40.9	12.4
8	15960.00	41.8 AV	54.0	-12.2	1.30 V	100	29.4	12.4

REMARKS:

1. Emission Level(dBuV/m) = Raw Value(dBuV) + Correction Factor(dB/m)
2. Correction Factor(dB/m) = Antenna Factor(dB/m) + Cable Factor(dB) – Pre-Amplifier Factor(dB)
3. The other emission levels were very low against the limit.
4. Margin value = Emission Level – Limit value
5. " * ": Fundamental frequency.

CHANNEL	TX Channel 100	DETECTOR FUNCTION	Peak (PK)
FREQUENCY RANGE	1GHz ~ 40GHz		Average (AV)

ANTENNA POLARITY & TEST DISTANCE: HORIZONTAL AT 3 M

NO.	FREQ. (MHz)	EMISSION LEVEL (dBuV/m)	LIMIT (dBuV/m)	MARGIN (dB)	ANTENNA HEIGHT (m)	TABLE ANGLE (Degree)	RAW VALUE (dBuV)	CORRECTION FACTOR (dB/m)
1	#5470.00	64.0 PK	74.0	-10.0	1.54 H	304	60.5	3.5
2	#5470.00	51.1 AV	54.0	-2.9	1.54 H	304	47.6	3.5
3	*5500.00	105.9 PK			1.54 H	304	102.4	3.5
4	*5500.00	96.2 AV			1.54 H	304	92.7	3.5
5	11000.00	58.4 PK	74.0	-15.6	1.24 H	161	45.0	13.4
6	11000.00	47.3 AV	54.0	-6.7	1.24 H	161	33.9	13.4
7	#16500.00	48.1 PK	74.0	-25.9	1.00 H	75	33.6	14.5
8	#16500.00	36.9 AV	54.0	-17.1	1.00 H	75	22.4	14.5

ANTENNA POLARITY & TEST DISTANCE: VERTICAL AT 3 M

NO.	FREQ. (MHz)	EMISSION LEVEL (dBuV/m)	LIMIT (dBuV/m)	MARGIN (dB)	ANTENNA HEIGHT (m)	TABLE ANGLE (Degree)	RAW VALUE (dBuV)	CORRECTION FACTOR (dB/m)
1	#5470.00	68.0 PK	74.0	-6.0	1.25 V	306	64.5	3.5
2	#5470.00	53.6 AV	54.0	-0.4	1.25 V	306	50.1	3.5
3	*5500.00	109.5 PK			1.25 V	306	106.0	3.5
4	*5500.00	100.3 AV			1.25 V	306	96.8	3.5
5	11000.00	67.8 PK	74.0	-6.2	1.03 V	172	54.4	13.4
6	11000.00	53.0 AV	54.0	-1.0	1.03 V	172	39.6	13.4
7	#16500.00	52.1 PK	74.0	-21.9	1.33 V	101	37.6	14.5
8	#16500.00	40.9 AV	54.0	-13.1	1.33 V	101	26.4	14.5

REMARKS:

1. Emission Level(dBuV/m) = Raw Value(dBuV) + Correction Factor(dB/m)
2. Correction Factor(dB/m) = Antenna Factor(dB/m) + Cable Factor(dB) – Pre-Amplifier Factor(dB)
3. The other emission levels were very low against the limit.
4. Margin value = Emission Level – Limit value
5. " * ": Fundamental frequency.
6. " # ": The radiated frequency is out of the restricted band.

CHANNEL	TX Channel 116	DETECTOR FUNCTION	Peak (PK)
FREQUENCY RANGE	1GHz ~ 40GHz		Average (AV)

ANTENNA POLARITY & TEST DISTANCE: HORIZONTAL AT 3 M

NO.	FREQ. (MHz)	EMISSION LEVEL (dBuV/m)	LIMIT (dBuV/m)	MARGIN (dB)	ANTENNA HEIGHT (m)	TABLE ANGLE (Degree)	RAW VALUE (dBuV)	CORRECTION FACTOR (dB/m)
1	*5580.00	110.0 PK			1.45 H	279	106.4	3.6
2	*5580.00	100.4 AV			1.45 H	279	96.8	3.6
3	11160.00	59.3 PK	74.0	-14.7	1.29 H	158	46.4	12.9
4	11160.00	47.7 AV	54.0	-6.3	1.29 H	158	34.8	12.9
5	#16740.00	47.9 PK	74.0	-26.1	1.00 H	78	32.3	15.6
6	#16740.00	36.7 AV	54.0	-17.3	1.00 H	78	21.1	15.6

ANTENNA POLARITY & TEST DISTANCE: VERTICAL AT 3 M

NO.	FREQ. (MHz)	EMISSION LEVEL (dBuV/m)	LIMIT (dBuV/m)	MARGIN (dB)	ANTENNA HEIGHT (m)	TABLE ANGLE (Degree)	RAW VALUE (dBuV)	CORRECTION FACTOR (dB/m)
1	*5580.00	113.9 PK			1.08 V	306	110.3	3.6
2	*5580.00	104.3 AV			1.08 V	306	100.7	3.6
3	11160.00	67.2 PK	74.0	-6.8	1.50 V	181	54.3	12.9
4	11160.00	52.8 AV	54.0	-1.2	1.50 V	181	39.9	12.9
5	#16740.00	52.1 PK	74.0	-21.9	1.33 V	109	36.5	15.6
6	#16740.00	40.9 AV	54.0	-13.1	1.33 V	109	25.3	15.6

REMARKS:

1. Emission Level(dBuV/m) = Raw Value(dBuV) + Correction Factor(dB/m)
2. Correction Factor(dB/m) = Antenna Factor(dB/m) + Cable Factor(dB) – Pre-Amplifier Factor(dB)
3. The other emission levels were very low against the limit.
4. Margin value = Emission Level – Limit value
5. " * ": Fundamental frequency.
6. " # ": The radiated frequency is out of the restricted band.

CHANNEL	TX Channel 140	DETECTOR FUNCTION	Peak (PK)
FREQUENCY RANGE	1GHz ~ 40GHz		Average (AV)

ANTENNA POLARITY & TEST DISTANCE: HORIZONTAL AT 3 M

NO.	FREQ. (MHz)	EMISSION LEVEL (dBuV/m)	LIMIT (dBuV/m)	MARGIN (dB)	ANTENNA HEIGHT (m)	TABLE ANGLE (Degree)	RAW VALUE (dBuV)	CORRECTION FACTOR (dB/m)
1	*5700.00	106.1 PK			1.58 H	300	102.2	3.9
2	*5700.00	96.4 AV			1.58 H	300	92.5	3.9
3	#5725.00	65.1 PK	74.0	-8.9	1.58 H	300	61.1	4.0
4	#5725.00	51.3 AV	54.0	-2.7	1.58 H	300	47.3	4.0
5	11400.00	59.9 PK	74.0	-14.1	1.32 H	160	46.9	13.0
6	11400.00	48.1 AV	54.0	-5.9	1.32 H	160	35.1	13.0
7	#17100.00	48.2 PK	74.0	-25.8	1.00 H	86	30.8	17.4
8	#17100.00	37.0 AV	54.0	-17.0	1.00 H	86	19.6	17.4

ANTENNA POLARITY & TEST DISTANCE: VERTICAL AT 3 M

NO.	FREQ. (MHz)	EMISSION LEVEL (dBuV/m)	LIMIT (dBuV/m)	MARGIN (dB)	ANTENNA HEIGHT (m)	TABLE ANGLE (Degree)	RAW VALUE (dBuV)	CORRECTION FACTOR (dB/m)
1	*5700.00	110.1 PK			1.16 V	305	106.2	3.9
2	*5700.00	100.8 AV			1.16 V	305	96.9	3.9
3	#5725.00	67.9 PK	74.0	-6.1	1.16 V	305	63.9	4.0
4	#5725.00	53.9 AV	54.0	-0.1	1.16 V	305	49.9	4.0
5	11400.00	67.9 PK	74.0	-6.1	1.08 V	163	54.9	13.0
6	11400.00	53.2 AV	54.0	-0.8	1.08 V	163	40.2	13.0
7	#17100.00	51.5 PK	74.0	-22.5	1.30 V	105	34.1	17.4
8	#17100.00	40.5 AV	54.0	-13.5	1.30 V	105	23.1	17.4

REMARKS:

1. Emission Level(dBuV/m) = Raw Value(dBuV) + Correction Factor(dB/m)
2. Correction Factor(dB/m) = Antenna Factor(dB/m) + Cable Factor(dB) – Pre-Amplifier Factor(dB)
3. The other emission levels were very low against the limit.
4. Margin value = Emission Level – Limit value
5. " * ": Fundamental frequency.
6. " # ": The radiated frequency is out of the restricted band.

802.11ac (VHT40)

CHANNEL	TX Channel 54	DETECTOR FUNCTION	Peak (PK)
FREQUENCY RANGE	1GHz ~ 40GHz		Average (AV)

ANTENNA POLARITY & TEST DISTANCE: HORIZONTAL AT 3 M

NO.	FREQ. (MHz)	EMISSION LEVEL (dBuV/m)	LIMIT (dBuV/m)	MARGIN (dB)	ANTENNA HEIGHT (m)	TABLE ANGLE (Degree)	RAW VALUE (dBuV)	CORRECTION FACTOR (dB/m)
1	*5270.00	109.1 PK			1.58 H	279	105.9	3.2
2	*5270.00	98.5 AV			1.58 H	279	95.3	3.2
3	5350.00	63.5 PK	74.0	-10.5	1.58 H	279	60.1	3.4
4	5350.00	51.0 AV	54.0	-3.0	1.58 H	279	47.6	3.4
5	#10540.00	55.1 PK	74.0	-18.9	1.31 H	98	42.8	12.3
6	#10540.00	45.1 AV	54.0	-8.9	1.31 H	98	32.8	12.3
7	15810.00	47.8 PK	74.0	-26.2	1.01 H	45	34.9	12.9
8	15810.00	37.2 AV	54.0	-16.8	1.01 H	45	24.3	12.9

ANTENNA POLARITY & TEST DISTANCE: VERTICAL AT 3 M

NO.	FREQ. (MHz)	EMISSION LEVEL (dBuV/m)	LIMIT (dBuV/m)	MARGIN (dB)	ANTENNA HEIGHT (m)	TABLE ANGLE (Degree)	RAW VALUE (dBuV)	CORRECTION FACTOR (dB/m)
1	*5270.00	113.1 PK			1.16 V	297	109.9	3.2
2	*5270.00	102.9 AV			1.16 V	297	99.7	3.2
3	5350.00	66.7 PK	74.0	-7.3	1.16 V	297	63.3	3.4
4	5350.00	53.6 AV	54.0	-0.4	1.16 V	297	50.2	3.4
5	#10540.00	57.2 PK	74.0	-16.8	2.92 V	224	44.9	12.3
6	#10540.00	49.9 AV	54.0	-4.1	2.92 V	224	37.6	12.3
7	15810.00	49.2 PK	74.0	-24.8	1.49 V	89	36.3	12.9
8	15810.00	42.3 AV	54.0	-11.7	1.49 V	89	29.4	12.9

REMARKS:

- Emission Level(dBuV/m) = Raw Value(dBuV) + Correction Factor(dB/m)
- Correction Factor(dB/m) = Antenna Factor(dB/m) + Cable Factor(dB) – Pre-Amplifier Factor(dB)
- The other emission levels were very low against the limit.
- Margin value = Emission Level – Limit value
- " * ": Fundamental frequency.
- " # ": The radiated frequency is out of the restricted band.

CHANNEL	TX Channel 62	DETECTOR FUNCTION	Peak (PK)
FREQUENCY RANGE	1GHz ~ 40GHz		Average (AV)

ANTENNA POLARITY & TEST DISTANCE: HORIZONTAL AT 3 M

NO.	FREQ. (MHz)	EMISSION LEVEL (dBuV/m)	LIMIT (dBuV/m)	MARGIN (dB)	ANTENNA HEIGHT (m)	TABLE ANGLE (Degree)	RAW VALUE (dBuV)	CORRECTION FACTOR (dB/m)
1	*5310.00	104.4 PK			1.49 H	288	101.2	3.2
2	*5310.00	93.8 AV			1.49 H	288	90.6	3.2
3	5350.00	65.2 PK	74.0	-8.8	1.49 H	288	61.8	3.4
4	5350.00	51.1 AV	54.0	-2.9	1.49 H	288	47.7	3.4
5	10620.00	51.1 PK	74.0	-22.9	1.27 H	123	38.6	12.5
6	10620.00	40.8 AV	54.0	-13.2	1.27 H	123	28.3	12.5
7	15930.00	45.1 PK	74.0	-28.9	1.00 H	44	32.8	12.3
8	15930.00	34.9 AV	54.0	-19.1	1.00 H	44	22.6	12.3

ANTENNA POLARITY & TEST DISTANCE: VERTICAL AT 3 M

NO.	FREQ. (MHz)	EMISSION LEVEL (dBuV/m)	LIMIT (dBuV/m)	MARGIN (dB)	ANTENNA HEIGHT (m)	TABLE ANGLE (Degree)	RAW VALUE (dBuV)	CORRECTION FACTOR (dB/m)
1	*5310.00	107.1 PK			1.20 V	294	103.9	3.2
2	*5310.00	98.0 AV			1.20 V	294	94.8	3.2
3	5350.00	68.0 PK	74.0	-6.0	1.20 V	294	64.6	3.4
4	5350.00	53.6 AV	54.0	-0.4	1.20 V	294	50.2	3.4
5	10620.00	54.0 PK	74.0	-20.0	2.96 V	211	41.5	12.5
6	10620.00	44.1 AV	54.0	-9.9	2.96 V	211	31.6	12.5
7	15930.00	46.1 PK	74.0	-27.9	1.45 V	77	33.8	12.3
8	15930.00	35.6 AV	54.0	-18.4	1.45 V	77	23.3	12.3

REMARKS:

1. Emission Level(dBuV/m) = Raw Value(dBuV) + Correction Factor(dB/m)
2. Correction Factor(dB/m) = Antenna Factor(dB/m) + Cable Factor(dB) – Pre-Amplifier Factor(dB)
3. The other emission levels were very low against the limit.
4. Margin value = Emission Level – Limit value
5. " * ": Fundamental frequency.

CHANNEL	TX Channel 102	DETECTOR FUNCTION	Peak (PK)
FREQUENCY RANGE	1GHz ~ 40GHz		Average (AV)

ANTENNA POLARITY & TEST DISTANCE: HORIZONTAL AT 3 M

NO.	FREQ. (MHz)	EMISSION LEVEL (dBuV/m)	LIMIT (dBuV/m)	MARGIN (dB)	ANTENNA HEIGHT (m)	TABLE ANGLE (Degree)	RAW VALUE (dBuV)	CORRECTION FACTOR (dB/m)
1	#5470.00	65.4 PK	74.0	-8.6	1.56 H	281	61.9	3.5
2	#5470.00	51.4 AV	54.0	-2.6	1.56 H	281	47.9	3.5
3	*5510.00	99.8 PK			1.56 H	281	96.2	3.6
4	*5510.00	90.6 AV			1.56 H	281	87.0	3.6
5	11020.00	51.0 PK	74.0	-23.0	1.35 H	119	37.6	13.4
6	11020.00	40.0 AV	54.0	-14.0	1.35 H	119	26.6	13.4
7	#16530.00	44.0 PK	74.0	-30.0	1.05 H	43	29.3	14.7
8	#16530.00	32.9 AV	54.0	-21.1	1.05 H	43	18.2	14.7

ANTENNA POLARITY & TEST DISTANCE: VERTICAL AT 3 M

NO.	FREQ. (MHz)	EMISSION LEVEL (dBuV/m)	LIMIT (dBuV/m)	MARGIN (dB)	ANTENNA HEIGHT (m)	TABLE ANGLE (Degree)	RAW VALUE (dBuV)	CORRECTION FACTOR (dB/m)
1	#5470.00	68.0 PK	74.0	-6.0	1.02 V	288	64.5	3.5
2	#5470.00	53.8 AV	54.0	-0.2	1.02 V	288	50.3	3.5
3	*5510.00	104.1 PK			1.02 V	288	100.5	3.6
4	*5510.00	94.9 AV			1.02 V	288	91.3	3.6
5	11020.00	53.8 PK	74.0	-20.2	2.92 V	216	40.4	13.4
6	11020.00	43.3 AV	54.0	-10.7	2.92 V	216	29.9	13.4
7	#16530.00	45.4 PK	74.0	-28.6	1.42 V	66	30.7	14.7
8	#16530.00	35.5 AV	54.0	-18.5	1.42 V	66	20.8	14.7

REMARKS:

1. Emission Level(dBuV/m) = Raw Value(dBuV) + Correction Factor(dB/m)
2. Correction Factor(dB/m) = Antenna Factor(dB/m) + Cable Factor(dB) – Pre-Amplifier Factor(dB)
3. The other emission levels were very low against the limit.
4. Margin value = Emission Level – Limit value
5. " * ": Fundamental frequency.
6. " # ": The radiated frequency is out of the restricted band.

CHANNEL	TX Channel 110	DETECTOR FUNCTION	Peak (PK)
FREQUENCY RANGE	1GHz ~ 40GHz		Average (AV)

ANTENNA POLARITY & TEST DISTANCE: HORIZONTAL AT 3 M

NO.	FREQ. (MHz)	EMISSION LEVEL (dBuV/m)	LIMIT (dBuV/m)	MARGIN (dB)	ANTENNA HEIGHT (m)	TABLE ANGLE (Degree)	RAW VALUE (dBuV)	CORRECTION FACTOR (dB/m)
1	#5470.00	65.9 PK	74.0	-8.1	1.51 H	283	62.4	3.5
2	#5470.00	51.3 AV	54.0	-2.7	1.51 H	283	47.8	3.5
3	*5550.00	107.5 PK			1.51 H	283	104.0	3.5
4	*5550.00	98.1 AV			1.51 H	283	94.6	3.5
5	11100.00	54.5 PK	74.0	-19.5	1.26 H	94	41.5	13.0
6	11100.00	44.6 AV	54.0	-9.4	1.26 H	94	31.6	13.0
7	#16650.00	47.0 PK	74.0	-27.0	1.05 H	58	31.5	15.5
8	#16650.00	36.8 AV	54.0	-17.2	1.05 H	58	21.3	15.5

ANTENNA POLARITY & TEST DISTANCE: VERTICAL AT 3 M

NO.	FREQ. (MHz)	EMISSION LEVEL (dBuV/m)	LIMIT (dBuV/m)	MARGIN (dB)	ANTENNA HEIGHT (m)	TABLE ANGLE (Degree)	RAW VALUE (dBuV)	CORRECTION FACTOR (dB/m)
1	#5470.00	68.6 PK	74.0	-5.4	1.09 V	301	65.1	3.5
2	#5470.00	53.8 AV	54.0	-0.2	1.09 V	301	50.3	3.5
3	*5550.00	111.9 PK			1.09 V	301	108.4	3.5
4	*5550.00	102.4 AV			1.09 V	301	98.9	3.5
5	11100.00	56.7 PK	74.0	-17.3	2.88 V	226	43.7	13.0
6	11100.00	49.3 AV	54.0	-4.7	2.88 V	226	36.3	13.0
7	#16650.00	48.2 PK	74.0	-25.8	1.53 V	74	32.7	15.5
8	#16650.00	41.6 AV	54.0	-12.4	1.53 V	74	26.1	15.5

REMARKS:

1. Emission Level(dBuV/m) = Raw Value(dBuV) + Correction Factor(dB/m)
2. Correction Factor(dB/m) = Antenna Factor(dB/m) + Cable Factor(dB) – Pre-Amplifier Factor(dB)
3. The other emission levels were very low against the limit.
4. Margin value = Emission Level – Limit value
5. " * ": Fundamental frequency.
6. " # ": The radiated frequency is out of the restricted band.

CHANNEL	TX Channel 134	DETECTOR FUNCTION	Peak (PK)
FREQUENCY RANGE	1GHz ~ 40GHz		Average (AV)

ANTENNA POLARITY & TEST DISTANCE: HORIZONTAL AT 3 M

NO.	FREQ. (MHz)	EMISSION LEVEL (dBuV/m)	LIMIT (dBuV/m)	MARGIN (dB)	ANTENNA HEIGHT (m)	TABLE ANGLE (Degree)	RAW VALUE (dBuV)	CORRECTION FACTOR (dB/m)
1	*5670.00	106.9 PK			1.44 H	290	103.1	3.8
2	*5670.00	96.6 AV			1.44 H	290	92.8	3.8
3	#5725.00	61.2 PK	74.0	-12.8	1.44 H	290	57.2	4.0
4	#5725.00	51.0 AV	54.0	-3.0	1.44 H	290	47.0	4.0
5	11340.00	54.7 PK	74.0	-19.3	1.27 H	97	41.6	13.1
6	11340.00	45.0 AV	54.0	-9.0	1.27 H	97	31.9	13.1
7	#17010.00	46.4 PK	74.0	-27.6	1.02 H	59	28.9	17.5
8	#17010.00	36.5 AV	54.0	-17.5	1.02 H	59	19.0	17.5

ANTENNA POLARITY & TEST DISTANCE: VERTICAL AT 3 M

NO.	FREQ. (MHz)	EMISSION LEVEL (dBuV/m)	LIMIT (dBuV/m)	MARGIN (dB)	ANTENNA HEIGHT (m)	TABLE ANGLE (Degree)	RAW VALUE (dBuV)	CORRECTION FACTOR (dB/m)
1	*5670.00	110.7 PK			1.10 V	301	106.9	3.8
2	*5670.00	100.8 AV			1.10 V	301	97.0	3.8
3	#5725.00	64.6 PK	74.0	-9.4	1.10 V	301	60.6	4.0
4	#5725.00	53.8 AV	54.0	-0.2	1.10 V	301	49.8	4.0
5	11340.00	56.5 PK	74.0	-17.5	2.93 V	217	43.4	13.1
6	11340.00	49.3 AV	54.0	-4.7	2.93 V	217	36.2	13.1
7	#17010.00	48.1 PK	74.0	-25.9	1.48 V	84	30.6	17.5
8	#17010.00	41.2 AV	54.0	-12.8	1.48 V	84	23.7	17.5

REMARKS:

1. Emission Level(dBuV/m) = Raw Value(dBuV) + Correction Factor(dB/m)
2. Correction Factor(dB/m) = Antenna Factor(dB/m) + Cable Factor(dB) – Pre-Amplifier Factor(dB)
3. The other emission levels were very low against the limit.
4. Margin value = Emission Level – Limit value
5. " * ": Fundamental frequency.
6. " # ": The radiated frequency is out of the restricted band.

802.11ac (VHT80)

CHANNEL	TX Channel 58	DETECTOR FUNCTION	Peak (PK)
FREQUENCY RANGE	1GHz ~ 40GHz		Average (AV)

ANTENNA POLARITY & TEST DISTANCE: HORIZONTAL AT 3 M

NO.	FREQ. (MHz)	EMISSION LEVEL (dBuV/m)	LIMIT (dBuV/m)	MARGIN (dB)	ANTENNA HEIGHT (m)	TABLE ANGLE (Degree)	RAW VALUE (dBuV)	CORRECTION FACTOR (dB/m)
1	5150.00	50.1 PK	74.0	-23.9	1.52 H	306	47.2	2.9
2	5150.00	38.5 AV	54.0	-15.5	1.52 H	306	35.6	2.9
3	*5290.00	98.3 PK			1.52 H	306	95.1	3.2
4	*5290.00	87.2 AV			1.52 H	306	84.0	3.2
5	5350.00	62.1 PK	74.0	-11.9	1.52 H	306	58.7	3.4
6	5350.00	51.8 AV	54.0	-2.2	1.52 H	306	48.4	3.4
7	#10580.00	51.3 PK	74.0	-22.7	1.37 H	104	38.8	12.5
8	#10580.00	40.4 AV	54.0	-13.6	1.37 H	104	27.9	12.5
9	15870.00	44.2 PK	74.0	-29.8	1.03 H	42	31.7	12.5
10	15870.00	33.3 AV	54.0	-20.7	1.03 H	42	20.8	12.5

ANTENNA POLARITY & TEST DISTANCE: VERTICAL AT 3 M

NO.	FREQ. (MHz)	EMISSION LEVEL (dBuV/m)	LIMIT (dBuV/m)	MARGIN (dB)	ANTENNA HEIGHT (m)	TABLE ANGLE (Degree)	RAW VALUE (dBuV)	CORRECTION FACTOR (dB/m)
1	5150.00	53.7 PK	74.0	-20.3	1.06 V	296	50.8	2.9
2	5150.00	41.0 AV	54.0	-13.0	1.06 V	296	38.1	2.9
3	*5290.00	101.9 PK			1.06 V	296	98.7	3.2
4	*5290.00	91.5 AV			1.06 V	296	88.3	3.2
5	5350.00	66.6 PK	74.0	-7.4	1.06 V	296	63.2	3.4
6	5350.00	53.6 AV	54.0	-0.4	1.06 V	296	50.2	3.4
7	#10580.00	53.4 PK	74.0	-20.6	2.90 V	228	40.9	12.5
8	#10580.00	43.1 AV	54.0	-10.9	2.90 V	228	30.6	12.5
9	15870.00	44.9 PK	74.0	-29.1	1.39 V	81	32.4	12.5
10	15870.00	35.0 AV	54.0	-19.0	1.39 V	81	22.5	12.5

REMARKS:

- Emission Level(dBuV/m) = Raw Value(dBuV) + Correction Factor(dB/m)
- Correction Factor(dB/m) = Antenna Factor(dB/m) + Cable Factor(dB) – Pre-Amplifier Factor(dB)
- The other emission levels were very low against the limit.
- Margin value = Emission Level – Limit value
- " * ": Fundamental frequency.
- " # ": The radiated frequency is out of the restricted band.

CHANNEL	TX Channel 106	DETECTOR FUNCTION	Peak (PK)
FREQUENCY RANGE	1GHz ~ 40GHz		Average (AV)

ANTENNA POLARITY & TEST DISTANCE: HORIZONTAL AT 3 M

NO.	FREQ. (MHz)	EMISSION LEVEL (dBuV/m)	LIMIT (dBuV/m)	MARGIN (dB)	ANTENNA HEIGHT (m)	TABLE ANGLE (Degree)	RAW VALUE (dBuV)	CORRECTION FACTOR (dB/m)
1	#5470.00	62.0 PK	74.0	-12.0	1.37 H	279	58.5	3.5
2	#5470.00	51.5 AV	54.0	-2.5	1.37 H	279	48.0	3.5
3	*5530.00	96.8 PK			1.37 H	279	93.3	3.5
4	*5530.00	86.1 AV			1.37 H	279	82.6	3.5
5	#5725.00	47.1 PK	74.0	-26.9	1.37 H	279	43.1	4.0
6	#5725.00	34.5 AV	54.0	-19.5	1.37 H	279	30.5	4.0
7	11060.00	49.5 PK	74.0	-24.5	1.39 H	107	36.3	13.2
8	11060.00	38.4 AV	54.0	-15.6	1.39 H	107	25.2	13.2
9	#16590.00	43.1 PK	74.0	-30.9	1.05 H	54	27.7	15.4
10	#16590.00	31.6 AV	54.0	-22.4	1.05 H	54	16.2	15.4

ANTENNA POLARITY & TEST DISTANCE: VERTICAL AT 3 M

NO.	FREQ. (MHz)	EMISSION LEVEL (dBuV/m)	LIMIT (dBuV/m)	MARGIN (dB)	ANTENNA HEIGHT (m)	TABLE ANGLE (Degree)	RAW VALUE (dBuV)	CORRECTION FACTOR (dB/m)
1	#5470.00	68.2 PK	74.0	-5.8	1.04 V	289	64.7	3.5
2	#5470.00	53.6 AV	54.0	-0.4	1.04 V	289	50.1	3.5
3	*5530.00	100.9 PK			1.04 V	289	97.4	3.5
4	*5530.00	90.4 AV			1.04 V	289	86.9	3.5
5	#5725.00	50.0 PK	74.0	-24.0	1.04 V	289	46.0	4.0
6	#5725.00	38.1 AV	54.0	-15.9	1.04 V	289	34.1	4.0
7	11060.00	52.1 PK	74.0	-21.9	2.93 V	209	38.9	13.2
8	11060.00	41.9 AV	54.0	-12.1	2.93 V	209	28.7	13.2
9	#16590.00	44.1 PK	74.0	-29.9	1.37 V	66	28.7	15.4
10	#16590.00	34.3 AV	54.0	-19.7	1.37 V	66	18.9	15.4

REMARKS:

1. Emission Level(dBuV/m) = Raw Value(dBuV) + Correction Factor(dB/m)
2. Correction Factor(dB/m) = Antenna Factor(dB/m) + Cable Factor(dB) – Pre-Amplifier Factor(dB)
3. The other emission levels were very low against the limit.
4. Margin value = Emission Level – Limit value
5. " * ": Fundamental frequency.
6. " # ": The radiated frequency is out of the restricted band.

Below 1GHz Data:

802.11ac (VHT20)

CHANNEL	TX Channel 60	DETECTOR FUNCTION	Quasi-Peak (QP)
FREQUENCY RANGE	9kHz ~ 1GHz		

ANTENNA POLARITY & TEST DISTANCE: HORIZONTAL AT 3 M								
NO.	FREQ. (MHz)	EMISSION LEVEL (dBuV/m)	LIMIT (dBuV/m)	MARGIN (dB)	ANTENNA HEIGHT (m)	TABLE ANGLE (Degree)	RAW VALUE (dBuV)	CORRECTION FACTOR (dB/m)
1	41.66	21.6 QP	40.0	-18.4	2.00 H	268	35.1	-13.5
2	155.59	23.6 QP	43.5	-19.9	2.00 H	68	36.8	-13.2
3	304.51	25.4 QP	46.0	-20.6	1.00 H	45	38.0	-12.6
4	391.52	30.5 QP	46.0	-15.5	1.00 H	304	41.3	-10.8
5	478.50	30.1 QP	46.0	-15.9	2.00 H	30	38.4	-8.3
6	792.03	35.9 QP	46.0	-10.1	2.00 H	294	38.8	-2.9
ANTENNA POLARITY & TEST DISTANCE: VERTICAL AT 3 M								
NO.	FREQ. (MHz)	EMISSION LEVEL (dBuV/m)	LIMIT (dBuV/m)	MARGIN (dB)	ANTENNA HEIGHT (m)	TABLE ANGLE (Degree)	RAW VALUE (dBuV)	CORRECTION FACTOR (dB/m)
1	42.95	36.7 QP	40.0	-3.3	1.00 V	103	49.8	-13.1
2	98.46	25.1 QP	43.5	-18.4	1.00 V	360	43.2	-18.1
3	155.54	24.4 QP	43.5	-19.1	1.00 V	360	37.6	-13.2
4	478.53	27.1 QP	46.0	-18.9	1.00 V	150	35.4	-8.3
5	565.51	26.6 QP	46.0	-19.4	1.00 V	33	33.4	-6.8
6	792.03	34.4 QP	46.0	-11.6	1.00 V	360	37.3	-2.9

REMARKS:

1. Emission Level(dBuV/m) = Raw Value(dBuV) + Correction Factor(dB/m)
2. Correction Factor(dB/m) = Antenna Factor(dB/m) + Cable Factor(dB) – Pre-Amplifier Factor(dB)
3. The other emission levels were very low against the limit.
4. Margin value = Emission Level – Limit value

4.2 Conducted Emission Measurement

4.2.1 Limits of Conducted Emission Measurement

Frequency (MHz)	Conducted Limit (dBuV)	
	Quasi-peak	Average
0.15 - 0.5	66 - 56	56 - 46
0.50 - 5.0	56	46
5.0 - 30.0	60	50

Note: 1. The lower limit shall apply at the transition frequencies.

2. The limit decreases in line with the logarithm of the frequency in the range of 0.15 to 0.50MHz.

4.2.2 Test Instruments

DESCRIPTION & MANUFACTURER	MODEL NO.	SERIAL NO.	CALIBRATED DATE	CALIBRATED UNTIL
Test Receiver R&S	ESCS 30	847124/029	Oct. 24, 2016	Oct. 23, 2017
Line-Impedance Stabilization Network (for EUT) R&S	ESH3-Z5	848773/004	Oct. 26, 2016	Oct. 25, 2017
Line-Impedance Stabilization Network (for Peripheral) R&S	ENV216	100072	June 13, 2016	June 12, 2017
50 ohms Terminator	N/A	EMC-02	Sep. 29, 2016	Sep. 28, 2017
RF Cable	5D-FB	COCCAB-001	Sep. 30, 2016	Sep. 29, 2017
10 dB PAD Mini-Circuits	HAT-10+	CONATT-004	June 20, 2016	June 19, 2017
Software BVADT	BVADT_Cond_ V7.3.7.4	NA	NA	NA

Note:

1. The calibration interval of the above test instruments are 12 months and the calibrations are traceable to NML/ROC and NIST/USA.
2. The test was performed in Shielded Room No. 1.
3. Tested Date: Mar. 03 to 16, 2017

4.2.3 Test Procedure

- The EUT was placed 0.4 meters from the conducting wall of the shielded room with EUT being connected to the power mains through a line impedance stabilization network (LISN). Other support units were connected to the power mains through another LISN. The two LISNs provide 50 ohm/ 50uH of coupling impedance for the measuring instrument.
- Both lines of the power mains connected to the EUT were checked for maximum conducted interference.
- The frequency range from 150kHz to 30MHz was searched. Emission levels under (Limit - 20dB) was not recorded.

NOTE: All modes of operation were investigated and the worst-case emissions are reported.

4.2.4 Deviation from Test Standard

No deviation.

4.2.5 Test Setup

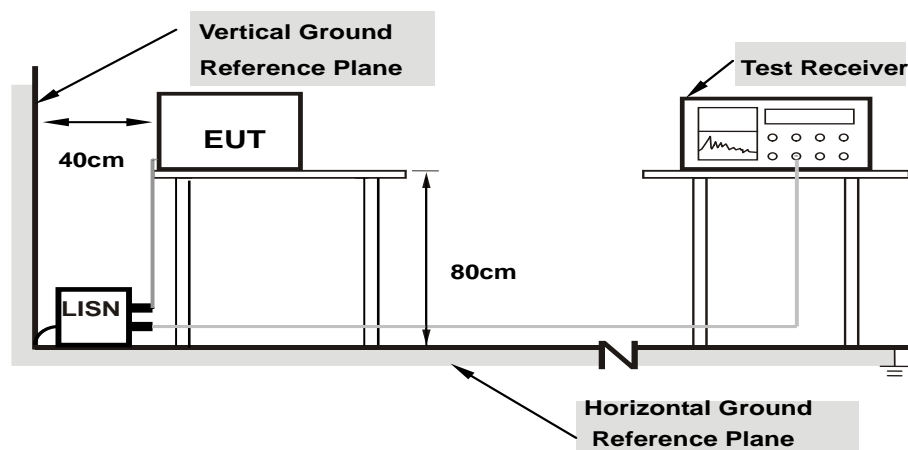

Note: 1.Support units were connected to second LISN.

For the actual test configuration, please refer to the attached file (Test Setup Photo).

4.2.6 EUT Operating Condition

Same as 4.1.6.

4.2.7 Test Results (Mode 1)

Phase	Line (L)	Detector Function	Quasi-Peak (QP) / Average (AV)
-------	----------	-------------------	--------------------------------

No	Freq. [MHz]	Corr.	Reading Value		Emission Level		Limit		Margin	
		Factor (dB)	[dB (uV)]		[dB (uV)]		[dB (uV)]		(dB)	
		Q.P.	AV.	Q.P.	AV.	Q.P.	AV.	Q.P.	AV.	
1	0.15000	10.20	36.16	25.95	46.36	36.15	66.00	56.00	-19.64	-19.85
2	0.38047	10.24	32.38	29.48	42.62	39.72	58.27	48.27	-15.65	-8.55
3	7.31250	10.54	25.90	23.78	36.44	34.32	60.00	50.00	-23.56	-15.68
4	12.00391	10.96	27.68	26.87	38.64	37.83	60.00	50.00	-21.36	-12.17
5	16.73438	11.44	25.04	19.59	36.48	31.03	60.00	50.00	-23.52	-18.97
6	24.00137	11.76	26.88	25.92	38.64	37.68	60.00	50.00	-21.36	-12.32

REMARKS:

1. Q.P. and AV. are abbreviations of quasi-peak and average individually.
2. The emission levels of other frequencies were very low against the limit.
3. Margin value = Emission level - Limit value
4. Correction factor = Insertion loss + Cable loss
5. Emission Level = Correction Factor + Reading Value.

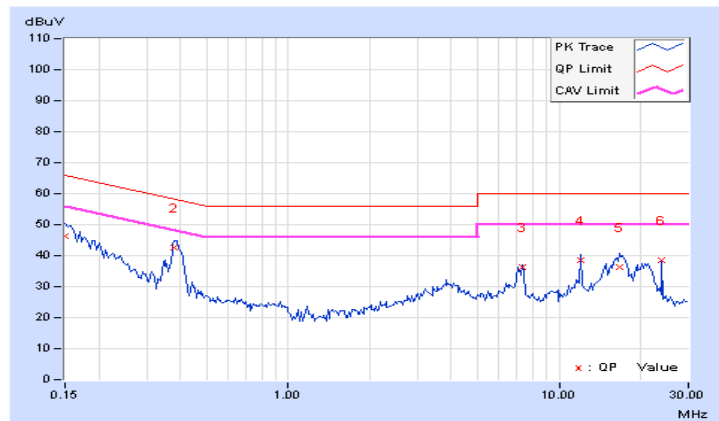

Phase	Neutral (N)	Detector Function	Quasi-Peak (QP) / Average (AV)
-------	-------------	-------------------	--------------------------------

No	Freq. [MHz]	Corr.	Reading Value		Emission Level		Limit		Margin	
		Factor (dB)	[dB (uV)]		[dB (uV)]		[dB (uV)]		(dB)	
			Q.P.	AV.	Q.P.	AV.	Q.P.	AV.	Q.P.	AV.
1	0.15000	10.19	36.02	25.08	46.21	35.27	66.00	56.00	-19.79	-20.73
2	0.38828	10.24	28.30	24.26	38.54	34.50	58.10	48.10	-19.56	-13.60
3	12.00000	10.81	28.89	28.06	39.70	38.87	60.00	50.00	-20.30	-11.13
4	16.89063	11.20	24.98	19.69	36.18	30.89	60.00	50.00	-23.82	-19.11
5	21.48047	11.38	19.73	14.75	31.11	26.13	60.00	50.00	-28.89	-23.87
6	24.00391	11.39	26.60	25.74	37.99	37.13	60.00	50.00	-22.01	-12.87

REMARKS:

1. Q.P. and AV. are abbreviations of quasi-peak and average individually.
2. The emission levels of other frequencies were very low against the limit.
3. Margin value = Emission level - Limit value
4. Correction factor = Insertion loss + Cable loss
5. Emission Level = Correction Factor + Reading Value.

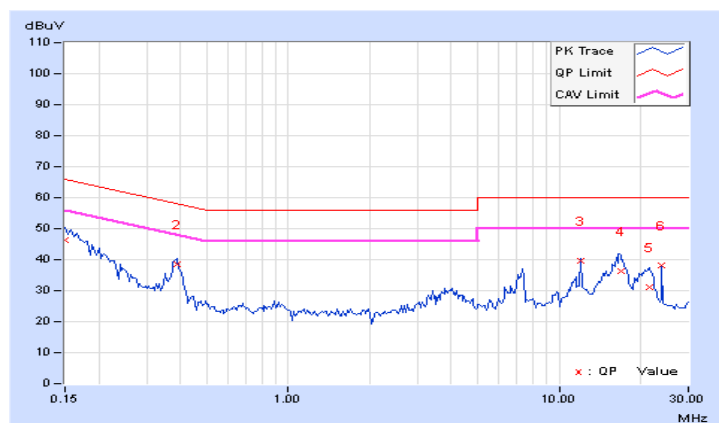

4.2.8 Test Results (Mode 2)

Phase	Line (L)	Detector Function	Quasi-Peak (QP) / Average (AV)
-------	----------	-------------------	--------------------------------

No	Freq. [MHz]	Corr.	Reading Value		Emission Level		Limit		Margin	
		Factor	[dB (uV)]		[dB (uV)]		[dB (uV)]		(dB)	
	(dB)	Q.P.	AV.	Q.P.	AV.	Q.P.	AV.	Q.P.	AV.	
1	0.17025	10.19	34.97	26.16	45.16	36.35	64.95	54.95	-19.79	-18.60
2	0.20469	10.19	30.01	20.64	40.20	30.83	63.42	53.42	-23.22	-22.59
3	0.50300	10.23	30.48	29.12	40.71	39.35	56.00	46.00	-15.29	-6.65
4	5.48438	10.32	23.69	14.52	34.01	24.84	60.00	50.00	-25.99	-25.16
5	15.35156	11.07	30.18	24.62	41.25	35.69	60.00	50.00	-18.75	-14.31
6	24.42969	11.42	31.27	25.36	42.69	36.78	60.00	50.00	-17.31	-13.22

REMARKS:

1. Q.P. and AV. are abbreviations of quasi-peak and average individually.
2. The emission levels of other frequencies were very low against the limit.
3. Margin value = Emission level - Limit value
4. Correction factor = Insertion loss + Cable loss
5. Emission Level = Correction Factor + Reading Value.

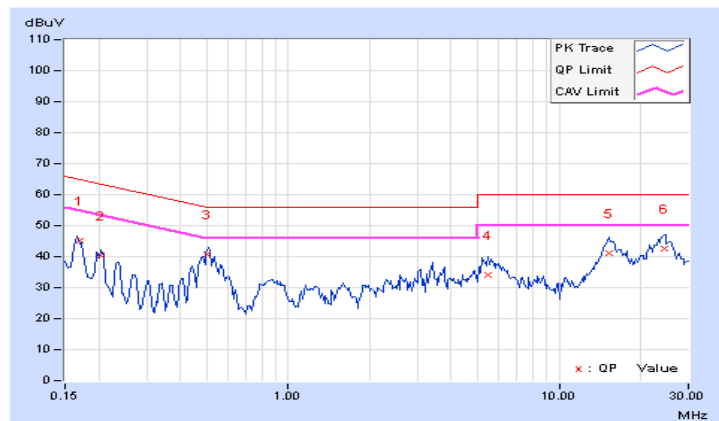

Phase	Neutral (N)	Detector Function	Quasi-Peak (QP) / Average (AV)
-------	-------------	-------------------	--------------------------------

No	Freq. [MHz]	Corr. Factor	Reading Value [dB (uV)]		Emission Level [dB (uV)]		Limit [dB (uV)]		Margin (dB)	
		(dB)	Q.P.	AV.	Q.P.	AV.	Q.P.	AV.	Q.P.	AV.
	1	0.16953	10.17	34.69	25.66	44.86	35.83	64.98	54.98	-20.12
2	0.20078	10.16	30.17	20.76	40.33	30.92	63.58	53.58	-23.25	-22.66
3	0.50391	10.21	30.64	29.42	40.85	39.63	56.00	46.00	-15.15	-6.37
4	5.27734	10.23	26.10	14.25	36.33	24.48	60.00	50.00	-23.67	-25.52
5	15.35547	10.90	30.45	24.89	41.35	35.79	60.00	50.00	-18.65	-14.21
6	23.89453	11.08	31.46	25.67	42.54	36.75	60.00	50.00	-17.46	-13.25

REMARKS:

1. Q.P. and AV. are abbreviations of quasi-peak and average individually.
2. The emission levels of other frequencies were very low against the limit.
3. Margin value = Emission level - Limit value
4. Correction factor = Insertion loss + Cable loss
5. Emission Level = Correction Factor + Reading Value.

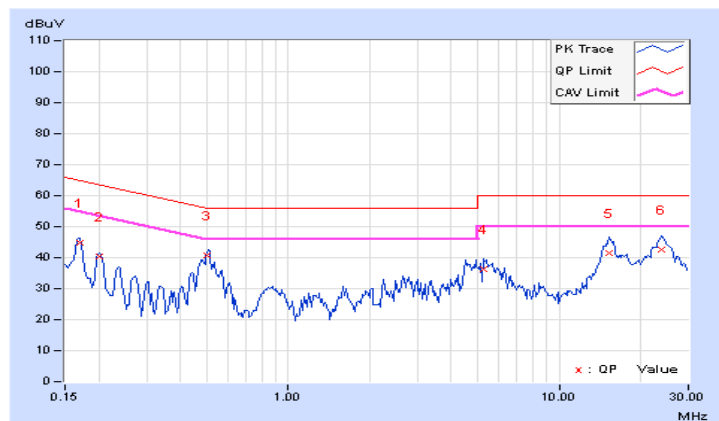

4.3 Transmit Power Measurement

4.3.1 Limits of Transmit Power Measurement

Operation Band	EUT Category		Limit
U-NII-1		Outdoor Access Point	1 Watt (30 dBm) (Max. e.i.r.p \leq 125mW(21 dBm) at any elevation angle above 30 degrees as measured from the horizon)
		Fixed point-to-point Access Point	1 Watt (30 dBm)
		Indoor Access Point	1 Watt (30 dBm)
		Mobile and Portable client device	250mW (24 dBm)
U-NII-2A		√	250mW (24 dBm) or 11 dBm+10 log B*
U-NII-2C		√	250mW (24 dBm) or 11 dBm+10 log B*
U-NII-3			1 Watt (30 dBm)

*B is the 26 dB emission bandwidth in megahertz

Per KDB 662911 Method of conducted output power measurement on IEEE 802.11 devices,

Array Gain = 0 dB (i.e., no array gain) for $N_{ANT} \leq 4$;

Array Gain = 0 dB (i.e., no array gain) for channel widths ≥ 40 MHz for any N_{ANT} ;

Array Gain = $5 \log(N_{ANT}/N_{SS})$ dB or 3 dB, whichever is less for 20-MHz channel widths with $N_{ANT} \geq 5$.

For power measurements on all other devices: Array Gain = $10 \log(N_{ANT}/N_{SS})$ dB.

4.3.2 Test Setup

FOR POWER OUTPUT MEASUREMENT

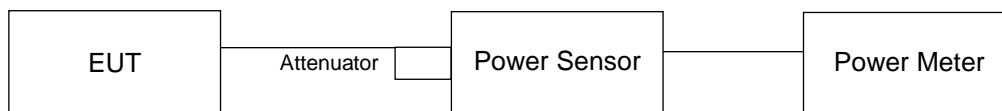

FOR 26dB OCCUPIED BANDWIDTH

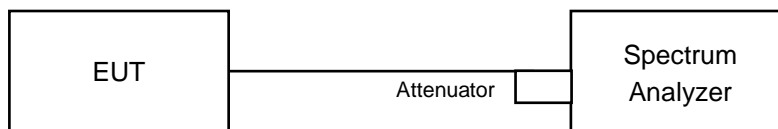

4.3.3 Test Instruments

Refer to section 4.1.2 to get information of above instrument.

4.3.4 Test Procedure

For Average Power Measurement

Method PM is used to perform output power measurement, trigger and gating function of wide band power meter is enabled to measure max output power of TX on burst. Duty factor is not added to measured value.

FOR 26dB OCCUPIED BANDWIDTH

1. Set RBW = approximately 1% of the emission bandwidth.
2. Set the VBW > RBW.
3. Detector = Peak.
4. Trace mode = max hold.
5. Measure the maximum width of the emission that is 26 dB down from the peak of the emission. Compare this with the RBW setting of the analyzer. Readjust RBW and repeat measurement as needed until the RBW/EBW ratio is approximately 1%.

4.3.5 Deviation from Test Standard

No deviation.

4.3.6 EUT Operating Condition

The software provided by client to enable the EUT under transmission condition continuously at lowest, middle and highest channel frequencies individually.

4.3.7 Test Result

802.11a

Power Output:

Chan.	Chan. Freq. (MHz)	Maximum Conducted Power (dBm)		Total Power (mW)	Total Power (dBm)	Limit (dBm)	Pass / Fail
		Chain 0	Chain 1				
52	5260	16.72	16.22	88.868	19.49	24.00	Pass
60	5300	16.32	16.54	87.937	19.44	24.00	Pass
64	5320	16.22	16.19	83.47	19.22	24.00	Pass
100	5500	15.58	15.28	69.87	18.44	24.00	Pass
116	5580	16.31	16.23	84.732	19.28	24.00	Pass
140	5700	15.52	15.30	69.529	18.42	24.00	Pass

26dB OCCUPIED BANDWIDTH

Channel	Frequency (MHz)	26dBc Bandwidth (MHz)	
		Chain 0	Chain 1
52	5260	34.24	35.85
60	5300	35.31	31.87
64	5320	36.86	34.62
100	5500	32.21	20.17
116	5580	34.18	29.73
140	5700	29.42	24.75

Note: For U-NII-2A, U-NII-2C Band output power limitation is determined based on 26dBc bandwidth

Power Limit = 11dBm + 10logB < U-NII-2A, U-NII-2C >			
Channel Number	Freq.(MHz)	Min. B(MHz)	Determined Conducted Limit (dBm)
52	5260	34.24	26.34 > 24
60	5300	31.87	26.03 > 24
64	5320	34.62	26.39 > 24
100	5500	20.17	24.04 > 24
116	5580	29.73	25.73 > 24
140	5700	24.75	24.93 > 24

802.11ac (VHT20)

Power Output:

Chan.	Chan. Freq. (MHz)	Maximum Conducted Power (dBm)		Total Power (mW)	Total Power (dBm)	Limit (dBm)	Pass / Fail
		Chain 0	Chain 1				
52	5260	16.61	16.31	88.57	19.47	24.00	Pass
60	5300	16.52	16.49	89.441	19.52	24.00	Pass
64	5320	16.00	16.02	79.805	19.02	24.00	Pass
100	5500	15.41	15.01	66.45	18.22	24.00	Pass
116	5580	16.38	16.12	84.377	19.26	24.00	Pass
140	5700	16.02	15.64	76.638	18.84	24.00	Pass

26dB OCCUPIED BANDWIDTH

Channel	Frequency (MHz)	26dBc Bandwidth (MHz)	
		Chain 0	Chain 1
52	5260	36.40	33.52
60	5300	37.57	34.42
64	5320	34.72	31.76
100	5500	23.81	20.99
116	5580	33.43	29.64
140	5700	32.35	27.16

Note: For U-NII-2A, U-NII-2C Band output power limitation is determined based on 26dBc bandwidth

Power Limit = 11dBm + 10logB < U-NII-2A, U-NII-2C >			
Channel Number	Freq.(MHz)	Min. B(MHz)	Determined Conducted Limit (dBm)
52	5260	33.52	26.25 > 24
60	5300	34.42	26.36 > 24
64	5320	31.76	26.01 > 24
100	5500	20.99	24.22 > 24
116	5580	29.64	25.71 > 24
140	5700	27.16	25.33 > 24

802.11ac (VHT40)

Power Output:

Chan.	Chan. Freq. (MHz)	Maximum Conducted Power (dBm)		Total Power (mW)	Total Power (dBm)	Limit (dBm)	Pass / Fail
		Chain 0	Chain 1				
54	5270	16.87	15.99	88.36	19.46	24.00	Pass
62	5310	13.10	13.04	40.554	16.08	24.00	Pass
102	5510	10.52	9.61	20.413	13.10	24.00	Pass
110	5550	16.40	15.94	82.916	19.19	24.00	Pass
134	5670	15.73	15.30	71.295	18.53	24.00	Pass

26dB OCCUPIED BANDWIDTH

Channel	Frequency (MHz)	26dBc Bandwidth (MHz)	
		Chain 0	Chain 1
54	5270	79.34	68.72
62	5310	42.41	41.63
102	5510	42.23	42.51
110	5550	68.02	50.78
134	5670	74.66	56.04

Note: For U-NII-2A, U-NII-2C Band output power limitation is determined based on 26dBc bandwidth

Power Limit = 11dBm + 10logB < U-NII-2A, U-NII-2C >			
Channel Number	Freq.(MHz)	Min. B(MHz)	Determined Conducted Limit (dBm)
54	5270	68.72	29.37 > 24
62	5310	41.63	27.19 > 24
102	5510	42.23	27.25 > 24
110	5550	50.78	28.05 > 24
134	5670	56.04	28.48 > 24

802.11ac (VHT80)

Power Output:

Chan.	Chan. Freq. (MHz)	Maximum Conducted Power (dBm)		Total Power (mW)	Total Power (dBm)	Limit (dBm)	Pass / Fail
		Chain 0	Chain 1				
58	5290	10.77	10.56	23.316	13.68	24.00	Pass
106	5530	9.60	8.58	16.331	12.13	24.00	Pass

26dB OCCUPIED BANDWIDTH

Channel	Frequency (MHz)	26dBc Bandwidth (MHz)	
		Chain 0	Chain 1
58	5290	83.97	85.00
106	5530	85.93	84.50

Note: For U-NII-2A, U-NII-2C Band output power limitation is determined based on 26dBc bandwidth

Power Limit = 11dBm + 10logB < U-NII-2A, U-NII-2C >			
Channel Number	Freq.(MHz)	Min. B(MHz)	Determined Conducted Limit (dBm)
58	5290	83.97	30.24 > 24
106	5530	84.50	30.26 > 24

Spectrum Plot of Worst Value

802.11a_Chain 1 / CH100

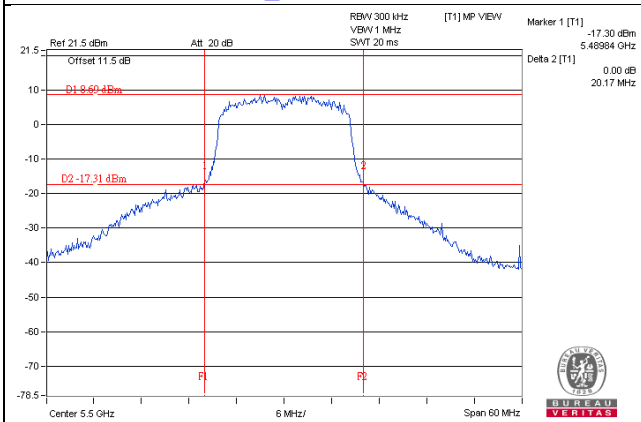

802.11ac (VHT20)_Chain 1 / CH100

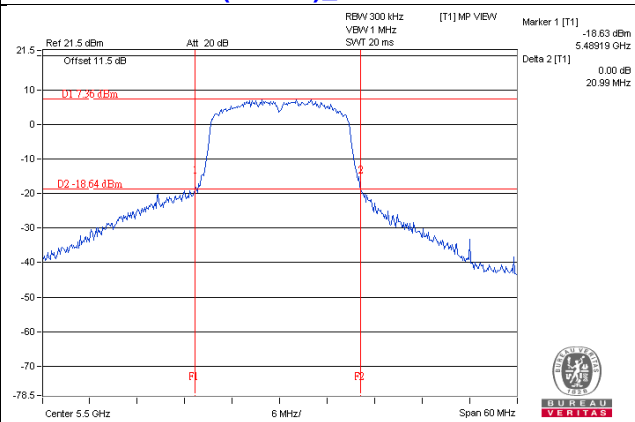

802.11ac (VHT40)_Chain 1 / CH62

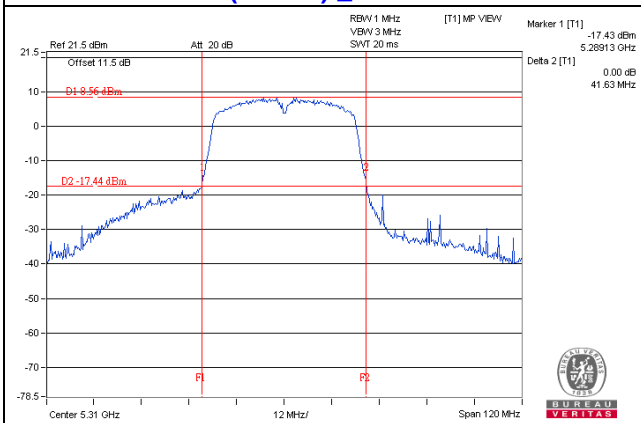

802.11ac (VHT80)_Chain 0 / CH58

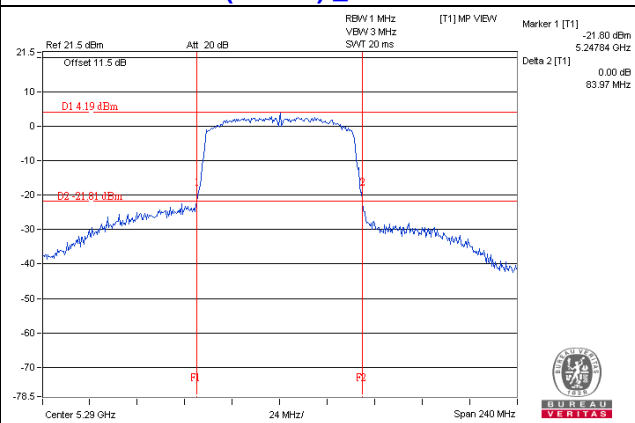

4.4 Occupied Bandwidth Measurement

4.4.1 Test Setup

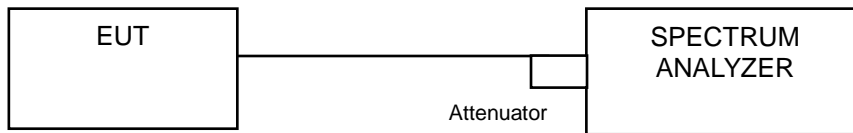

4.4.2 Test Instruments

Refer to section 4.1.2 to get information of above instrument.

4.4.3 Test Procedure

The transmitter output was connected to the spectrum analyzer through an attenuator. The bandwidth of the fundamental frequency was measured by spectrum analyzer with resolution bandwidth in the range of 1% to 5% of the anticipated emission bandwidth, and a video bandwidth at least 3x the resolution bandwidth and set the detector to SAMPLE. The width of a frequency band such that, below the lower and above the upper frequency limits, the mean powers emitted are each equal to a specified percentage 0.5 %of the total mean power of a given emission.

4.4.4 Test Results

802.11a

Channel	Channel Frequency (MHz)	Occupied Bandwidth (MHz)	
		CHAIN 0	CHAIN 1
52	5260	17.04	17.76
60	5300	17.28	16.80
64	5320	18.96	17.28
100	5500	16.68	16.44
116	5580	18.36	17.04
140	5700	16.68	16.56

802.11ac (VHT20)

Channel	Channel Frequency (MHz)	Occupied Bandwidth (MHz)	
		CHAIN 0	CHAIN 1
52	5260	18.36	17.76
60	5300	18.60	17.76
64	5320	18.12	17.76
100	5500	17.64	17.64
116	5580	17.88	17.76
140	5700	17.88	17.64

802.11ac (VHT40)

Channel	Channel Frequency (MHz)	Occupied Bandwidth (MHz)	
		CHAIN 0	CHAIN 1
54	5270	37.68	36.72
62	5310	36.00	36.24
102	5510	36.24	36.24
110	5550	36.48	36.24
134	5670	36.48	36.48

802.11ac (VHT80)

Channel	Channel Frequency (MHz)	Occupied Bandwidth (MHz)	
		CHAIN 0	CHAIN 1
58	5290	75.36	75.36
106	5530	75.36	74.88

Spectrum Plot of Worst Value

802.11a_Chain0 / CH64

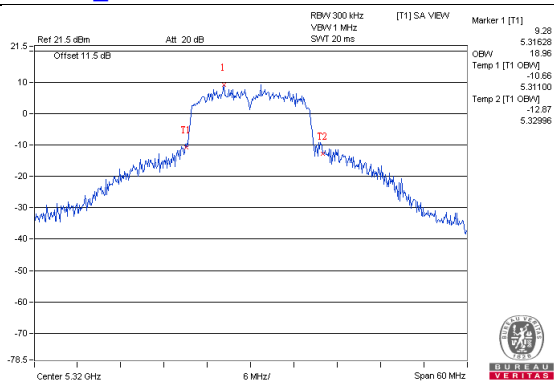

802.11ac (VHT20)_Chain0 / CH60

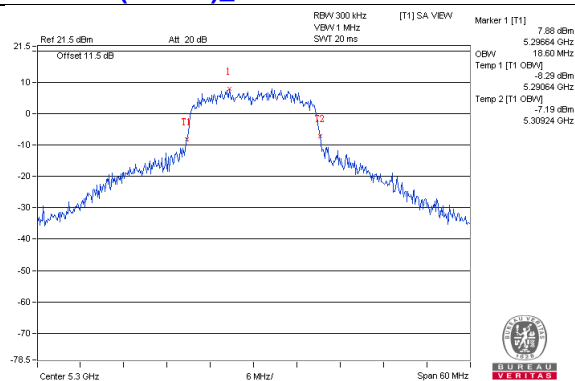

802.11ac (VHT40)_Chain0 / CH54

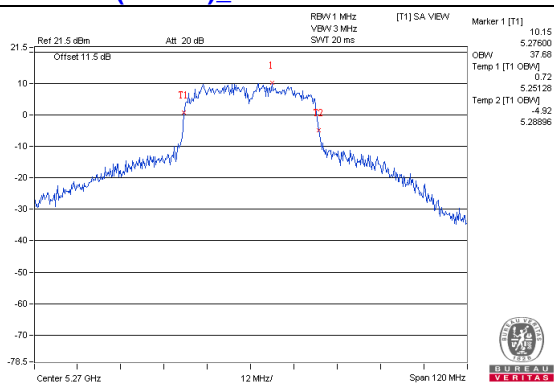

802.11ac (VHT80)_Chain0 / CH58

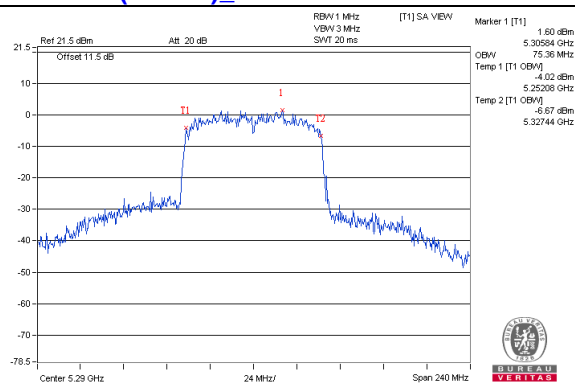

Verify that the 5600 – 5650 MHz band is notched.
 Test results demonstrating last channel shall not exceed the band edge on 5600-5650MHz

802.11a / Chain 0 – CH116

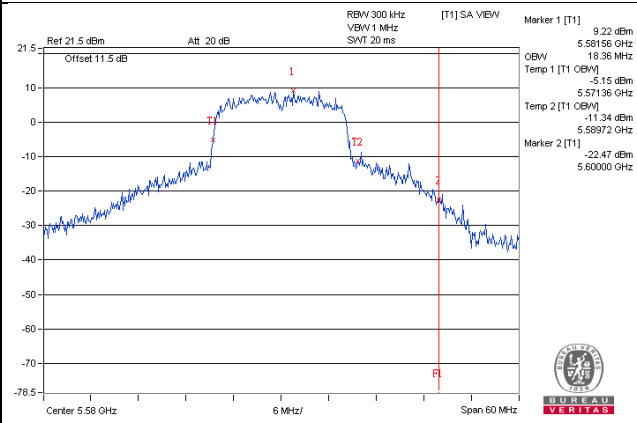

802.11a / Chain 1 – CH116

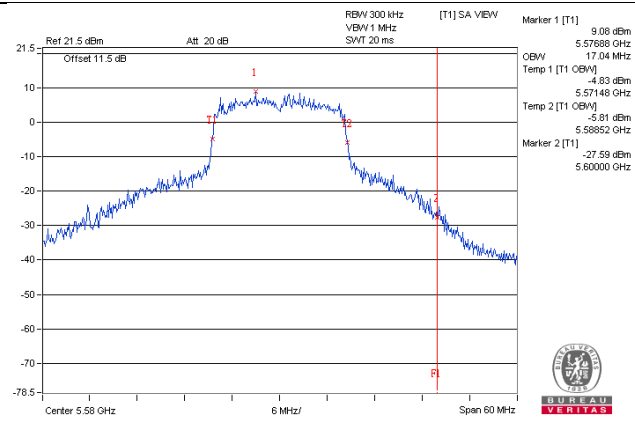

802.11a / Chain 0 – CH132

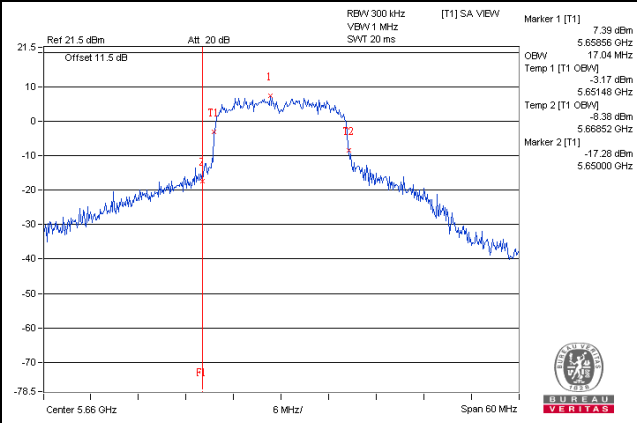

802.11a / Chain 1 – CH132

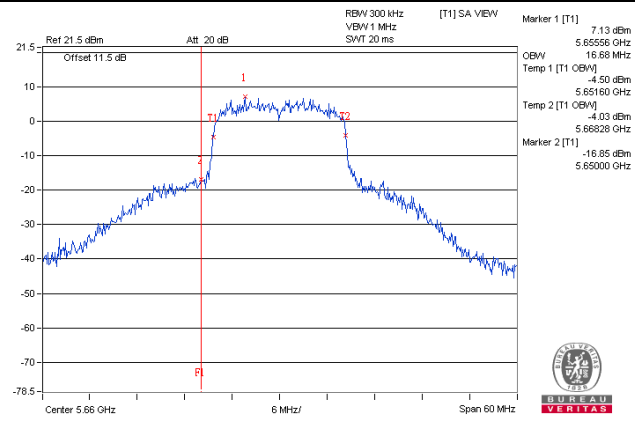

Verify that the 5600 – 5650 MHz band is notched.
Test results demonstrating last channel shall not exceed the band edge on 5600-5650MHz

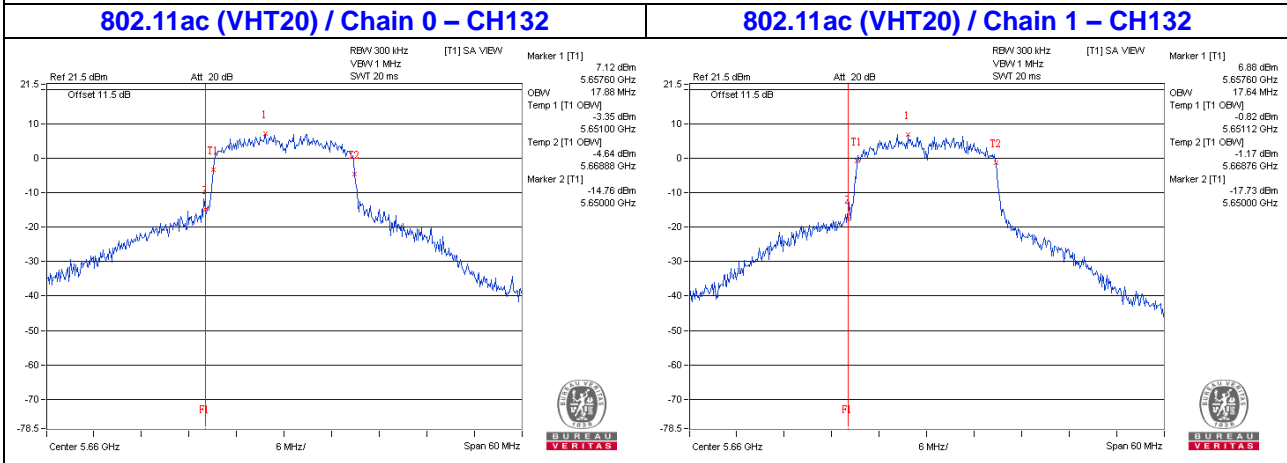
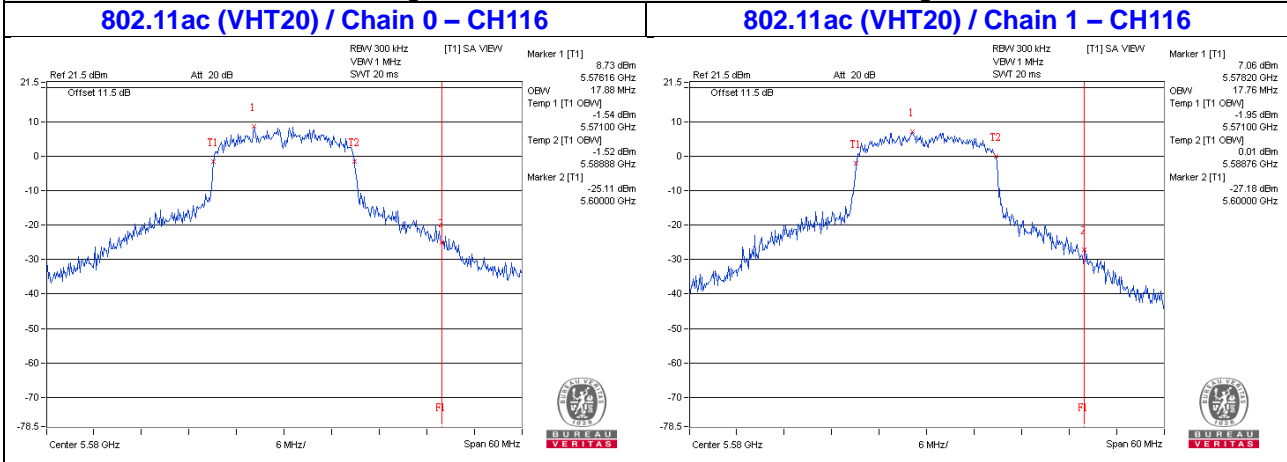

Verify that the 5600 – 5650 MHz band is notched.
Test results demonstrating last channel shall not exceed the band edge on 5600-5650MHz

802.11ac (VHT40) / Chain 0 – CH110

802.11ac (VHT40) / Chain 1 – CH110

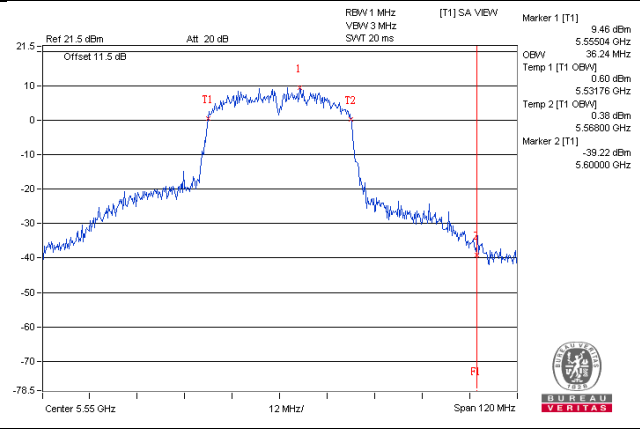
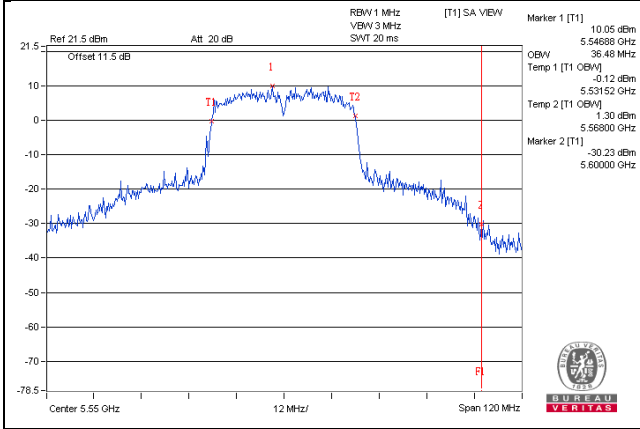

802.11ac (VHT40) / Chain 0 – CH134

802.11ac (VHT40) / Chain 1 – CH134

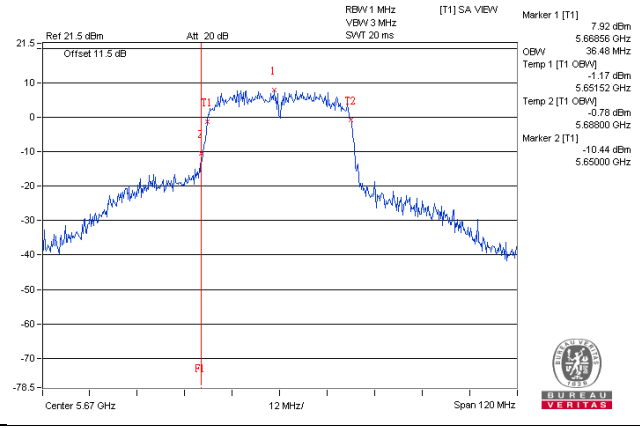
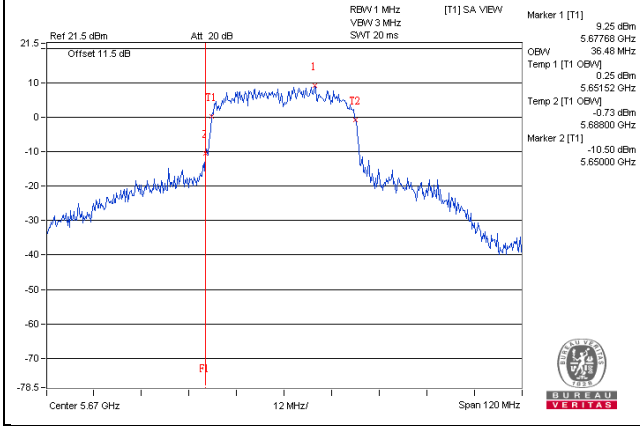

Verify that the 5600 – 5650 MHz band is notched.
Test results demonstrating last channel shall not exceed the band edge on 5600-5650MHz

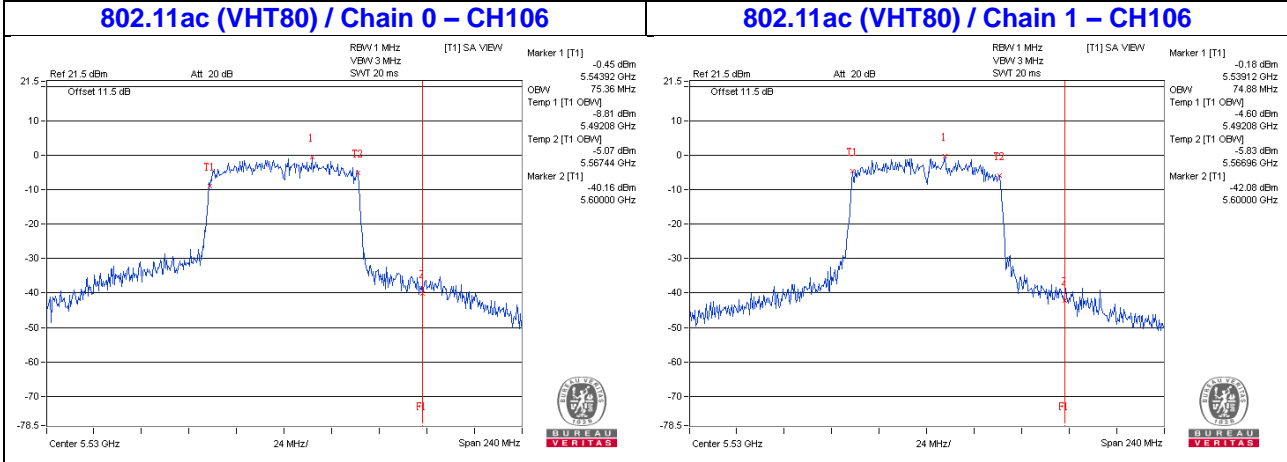

4.5 Peak Power Spectral Density Measurement

4.5.1 Limits of Peak Power Spectral Density Measurement

Operation Band	EUT Category		Limit
U-NII-1		Outdoor Access Point	17dBm/ MHz
		Fixed point-to-point Access Point	
		Indoor Access Point	
		Mobile and Portable client device	11dBm/ MHz
U-NII-2A	√		11dBm/ MHz
U-NII-2C	√		11dBm/ MHz
U-NII-3			30dBm/ 500kHz

4.5.2 Test Setup

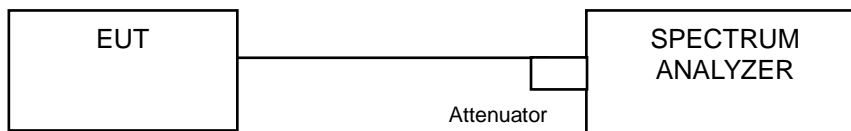

4.5.3 Test Instruments

Refer to section 4.1.2 to get information of above instrument.

4.5.4 Test Procedure

802.11a, 802.11ac (VHT20), 802.11ac (VHT40)

Using method SA-1

1. Set span to encompass the entire emission bandwidth (EBW) of the signal.
2. Set RBW = 1 MHz, Set VBW ≥ 3 MHz, Detector = RMS
3. Sweep time = auto, trigger set to “free run”.
4. Trace average at least 100 traces in power averaging mode.
5. Record the max value

802.11ac (VHT80)

Using method SA-2

1. Set span to encompass the entire emission bandwidth (EBW) of the signal.
2. Set RBW = 1 MHz, Set VBW ≥ 3 MHz, Detector = RMS
3. Sweep time = auto, trigger set to “free run”.
4. Trace average at least 100 traces in power averaging mode.
5. Record the max value and add 10 log (1/duty cycle)

4.5.5 Deviation from Test Standard

No deviation.

4.5.6 EUT Operating Condition

Same as Item 4.3.6.

4.5.7 Test Results

802.11a

Chan.	Chan. Freq. (MHz)	PSD (dBm/MHz)		Total Power Density (dBm/MHz)	MAX. Limit (dBm/MHz)	Pass / Fail
		Chain 0	Chain 1			
52	5260	3.97	3.41	6.71	10.60	Pass
60	5300	3.33	3.23	6.29	10.60	Pass
64	5320	4.10	3.79	6.96	10.60	Pass
100	5500	3.39	2.72	6.08	10.52	Pass
116	5580	4.76	4.05	7.43	10.52	Pass
140	5700	2.70	1.95	5.35	10.52	Pass

- Note:** 1. Method a) of power density measurement of KDB 662911 is using for calculating total power density. Total power density is summing entire spectra across corresponding frequency bins on the various outputs by computer.
2. For UNII-2A: Directional gain = $10 \log[(10^{G1/20} + 10^{G2/20})^2 / 2] = 6.4\text{dBi} > 6\text{dBi}$, so the power density limit shall be reduced to $11-(6.4-6) = 10.60\text{dBm}$.
3. For UNII-2C: Directional gain = $10 \log[(10^{G1/20} + 10^{G2/20})^2 / 2] = 6.48\text{dBi} > 6\text{dBi}$, so the power density limit shall be reduced to $11-(6.48-6) = 10.52\text{dBm}$.

802.11ac (VHT20)

Chan.	Chan. Freq. (MHz)	PSD (dBm/MHz)		Total Power Density (dBm/MHz)	MAX. Limit (dBm/MHz)	Pass / Fail
		Chain 0	Chain 1			
52	5260	3.62	3.02	6.34	10.60	Pass
60	5300	3.76	3.36	6.57	10.60	Pass
64	5320	3.48	3.05	6.28	10.60	Pass
100	5500	2.19	1.91	5.06	10.52	Pass
116	5580	3.83	3.43	6.64	10.52	Pass
140	5700	2.75	1.90	5.36	10.52	Pass

- Note:** 1. Method a) of power density measurement of KDB 662911 is using for calculating total power density. Total power density is summing entire spectra across corresponding frequency bins on the various outputs by computer.
2. For UNII-2A: Directional gain = $10 \log[(10^{G1/20} + 10^{G2/20})^2 / 2] = 6.4\text{dBi} > 6\text{dBi}$, so the power density limit shall be reduced to $11-(6.4-6) = 10.60\text{dBm}$.
3. For UNII-2C: Directional gain = $10 \log[(10^{G1/20} + 10^{G2/20})^2 / 2] = 6.48\text{dBi} > 6\text{dBi}$, so the power density limit shall be reduced to $11-(6.48-6) = 10.52\text{dBm}$.

802.11ac (VHT40)

Chan.	Chan. Freq. (MHz)	PSD (dBm/MHz)		Total Power Density (dBm/MHz)	MAX. Limit (dBm/MHz)	Pass / Fail
		Chain 0	Chain 1			
54	5270	0.52	-0.41	3.09	10.60	Pass
62	5310	-2.97	-3.42	-0.18	10.60	Pass
102	5510	-6.05	-7.38	-3.65	10.52	Pass
110	5550	-0.17	-1.15	2.38	10.52	Pass
134	5670	-0.80	-1.66	1.80	10.52	Pass

- Note:** 1. Method a) of power density measurement of KDB 662911 is using for calculating total power density. Total power density is summing entire spectra across corresponding frequency bins on the various outputs by computer.
2. For UNII-2A: Directional gain = $10 \log[(10^{G1/20} + 10^{G2/20})^2 / 2] = 6.4\text{dBi} > 6\text{dBi}$, so the power density limit shall be reduced to $11-(6.4-6) = 10.60\text{dBm}$.
3. For UNII-2C: Directional gain = $10 \log[(10^{G1/20} + 10^{G2/20})^2 / 2] = 6.48\text{dBi} > 6\text{dBi}$, so the power density limit shall be reduced to $11-(6.48-6) = 10.52\text{dBm}$.

802.11ac (VHT80)

Chan.	Chan. Freq. (MHz)	PSD W/O Duty Factor (dBm/MHz)		Duty Factor (dB)	Total PSD With Duty Factor (dBm/MHz)	MAX. Limit (dBm/MHz)	Pass / Fail
		Chain 0	Chain 1				
58	5290	-8.45	-9.07	0.09	-5.64	10.60	Pass
106	5530	-10.18	-10.49	0.09	-7.23	10.52	Pass

- Note:** 1. Method a) of power density measurement of KDB 662911 is using for calculating total power density. Total power density is summing entire spectra across corresponding frequency bins on the various outputs by computer.
2. For UNII-2A: Directional gain = $10 \log[(10^{G1/20} + 10^{G2/20})^2 / 2] = 6.4\text{dBi} > 6\text{dBi}$, so the power density limit shall be reduced to $11-(6.4-6) = 10.60\text{dBm}$.
3. For UNII-2C: Directional gain = $10 \log[(10^{G1/20} + 10^{G2/20})^2 / 2] = 6.48\text{dBi} > 6\text{dBi}$, so the power density limit shall be reduced to $11-(6.48-6) = 10.52\text{dBm}$.
4. Refer to section 3.3 for duty cycle spectrum plot.

Spectrum Plot of Worst Value

802.11a_Chain 0 / CH116

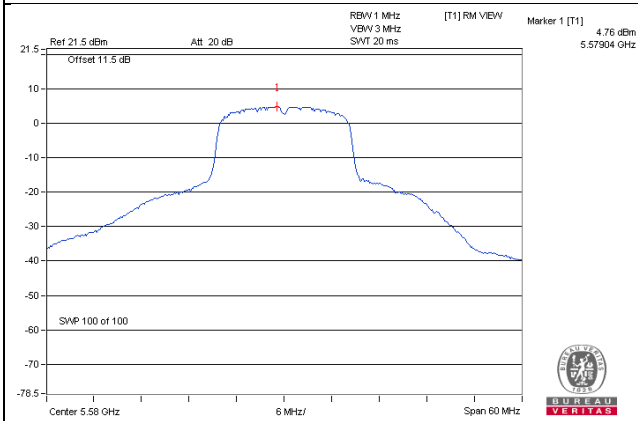

802.11ac (VHT20)_Chain 0 / CH116

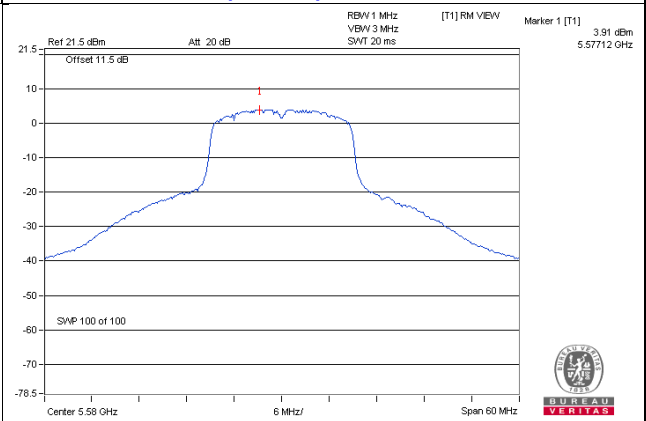

802.11ac (VHT40)_Chain 0 / CH54

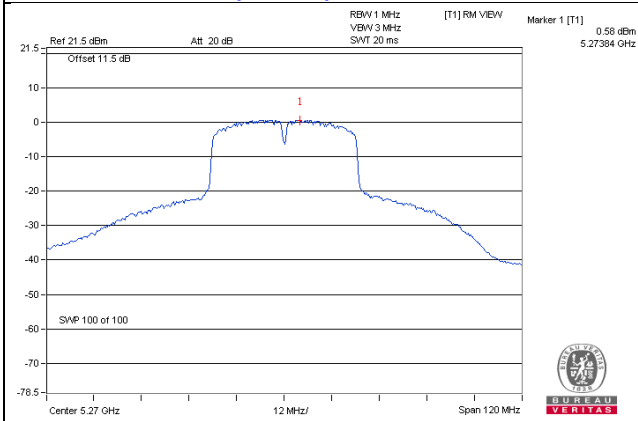

802.11ac (VHT80)_Chain 0 / CH58

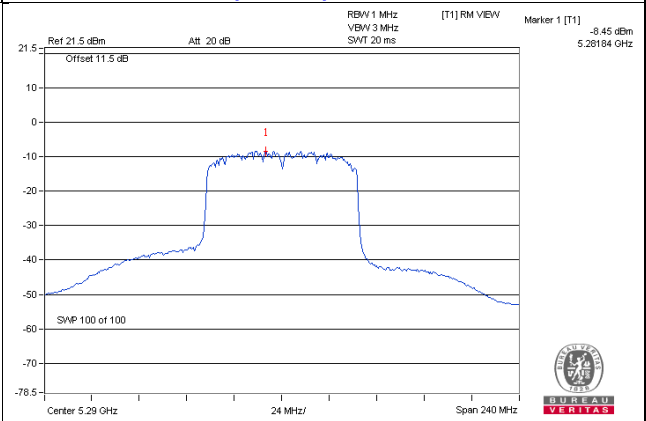

4.6 Frequency Stability Measurement

4.6.1 Limits of Frequency Stability Measurement

The frequency of the carrier signal shall be maintained within band of operation

4.6.2 Test Setup

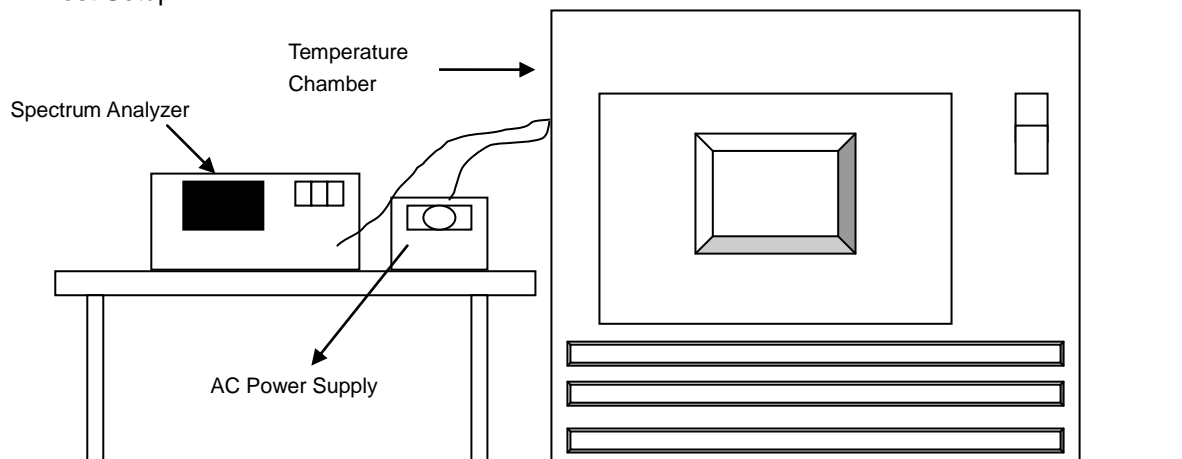

4.6.3 Test Instruments

Refer to section 4.1.2 to get information of above instrument.

4.6.4 Test Procedure

- The EUT was placed inside the environmental test chamber and powered by nominal AC voltage.
- Turn the EUT on and couple its output to a spectrum analyzer.
- Turn the EUT off and set the chamber to the highest temperature specified.
- Allow sufficient time (approximately 30 min) for the temperature of the chamber to stabilize, turn the EUT on and measure the operating frequency after 2, 5, and 10 Minutes.
- Repeat step 2 and 3 with the temperature chamber set to the lowest temperature.
- The test chamber was allowed to stabilize at +20 degree C for a minimum of 30 Minutes. The supply voltage was then adjusted on the EUT from 85% to 115% and the frequency record.

4.6.5 Deviation from Test Standard

No deviation.

4.6.6 EUT Operating Condition

Set the EUT transmit at un-modulation mode to test frequency stability.

4.6.7 Test Results

Frequency Stability Versus Temp.									
Operating Frequency: 5260 MHz									
TEMP. (°C)	Power Supply (Vac)	0 Minute		2 Minute		5 Minute		10 Minute	
		Measured Frequency (MHz)	Pass/Fail	Measured Frequency (MHz)	Pass/Fail	Measured Frequency (MHz)	Pass/Fail	Measured Frequency (MHz)	Pass/Fail
50	120	5259.9893	PASS	5259.9884	PASS	5259.9894	PASS	5259.985	PASS
40	120	5259.9905	PASS	5259.9918	PASS	5259.9924	PASS	5259.9925	PASS
30	120	5259.9972	PASS	5259.9953	PASS	5259.999	PASS	5259.9954	PASS
20	120	5259.9949	PASS	5259.9962	PASS	5259.995	PASS	5259.9981	PASS
10	120	5260.0204	PASS	5260.0184	PASS	5260.0201	PASS	5260.0207	PASS
0	120	5260.018	PASS	5260.0162	PASS	5260.0177	PASS	5260.0192	PASS
-10	120	5260.0062	PASS	5260.008	PASS	5260.008	PASS	5260.0036	PASS
-20	120	5260.0005	PASS	5260.0013	PASS	5260.0001	PASS	5260.0031	PASS
-30	120	5260.0197	PASS	5260.0199	PASS	5260.0202	PASS	5260.0202	PASS

Frequency Stability Versus Voltage									
Operating Frequency: 5260 MHz									
TEMP. (°C)	Power Supply (Vac)	0 Minute		2 Minute		5 Minute		10 Minute	
		Measured Frequency (MHz)	Pass/Fail	Measured Frequency (MHz)	Pass/Fail	Measured Frequency (MHz)	Pass/Fail	Measured Frequency (MHz)	Pass/Fail
20	138	5259.9952	PASS	5259.9953	PASS	5259.9947	PASS	5259.9988	PASS
	120	5259.9949	PASS	5259.9962	PASS	5259.995	PASS	5259.9981	PASS
	102	5259.9954	PASS	5259.9955	PASS	5259.9948	PASS	5259.9977	PASS

5 Pictures of Test Arrangements

Please refer to the attached file (Test Setup Photo).

Appendix – Information on the Testing Laboratories

We, Bureau Veritas Consumer Products Services (H.K.) Ltd., Taoyuan Branch, were founded in 1988 to provide our best service in EMC, Radio, Telecom and Safety consultation. Our laboratories are accredited and approved according to ISO/IEC 17025.

If you have any comments, please feel free to contact us at the following:

Linko EMC/RF Lab

Tel: 886-2-26052180

Fax: 886-2-26051924

Hsin Chu EMC/RF/Telecom Lab

Tel: 886-3-6668565

Fax: 886-3-6668323

Hwa Ya EMC/RF/Safety Lab

Tel: 886-3-3183232

Fax: 886-3-3270892

Email: service.adt@tw.bureauveritas.com

Web Site: www.bureauveritas-adt.com

The address and road map of all our labs can be found in our web site also.

--- END ---