

FCC Test Report (WLAN)

Report No.: RF170209C07-1

FCC ID: 2AAEDWP2117

Test Model: WiCS-2100

Received Date: Feb. 09, 2017

Test Date: Mar. 03 to 16, 2017

Issued Date: Mar. 29, 2016

Applicant: Barco NV

Address: President Kennedypark 35, 8500 Kortrijk, Belgium

Issued By: Bureau Veritas Consumer Products Services (H.K.) Ltd., Taoyuan Branch
Hsin Chu Laboratory

Lab Address: E-2, No.1, Li Hsin 1st Road, Hsinchu Science Park, Hsinchu City 300,
Taiwan R.O.C.

Test Location (1): E-2, No.1, Li Hsin 1st Road, Hsinchu Science Park, Hsinchu City 300,
Taiwan R.O.C.

Test Location (2): No. 49, Ln. 206, Wende Rd., Shangshan Tsuen, Chiung Lin Hsiang, Hsin
Chu Hsien 307, Taiwan R.O.C.



This report is for your exclusive use. Any copying or replication of this report to or for any other person or entity, or use of our name or trademark, is permitted only with our prior written permission. This report sets forth our findings solely with respect to the test samples identified herein. The results set forth in this report are not indicative or representative of the quality or characteristics of the lot from which a test sample was taken or any similar or identical product unless specifically and expressly noted. Our report includes all of the tests requested by you and the results thereof based upon the information that you provided to us. You have 60 days from date of issuance of this report to notify us of any material error or omission caused by our negligence, provided, however, that such notice shall be in writing and shall specifically address the issue you wish to raise. A failure to raise such issue within the prescribed time shall constitute your unqualified acceptance of the completeness of this report, the tests conducted and the correctness of the report contents. Unless specific mention, the uncertainty of measurement has been explicitly taken into account to declare the compliance or non-compliance to the specification. The report must not be used by the client to claim product certification, approval, or endorsement by TAF or any government agencies.

Table of Contents

Release Control Record	4
1 Certificate of Conformity	5
2 Summary of Test Results	6
2.1 Measurement Uncertainty	6
2.2 Modification Record	6
3 General Information	7
3.1 General Description of EUT	7
3.2 Description of Test Modes	9
3.2.1 Test Mode Applicability and Tested Channel Detail	10
3.3 Duty Cycle of Test Signal	12
3.4 Description of Support Units	13
3.4.1 Configuration of System under Test	14
3.5 General Description of Applied Standard	16
4 Test Types and Results	17
4.1 Radiated Emission and Bandedge Measurement	17
4.1.1 Limits of Radiated Emission and Bandedge Measurement	17
4.1.2 Test Instruments	18
4.1.3 Test Procedure	20
4.1.4 Deviation from Test Standard	20
4.1.5 Test Setup	21
4.1.6 EUT Operating Condition	22
4.1.7 Test Results	23
4.2 Conducted Emission Measurement	42
4.2.1 Limits of Conducted Emission Measurement	42
4.2.2 Test Instruments	42
4.2.3 Test Procedure	43
4.2.4 Deviation from Test Standard	43
4.2.5 Test Setup	43
4.2.6 EUT Operating Condition	43
4.2.7 Test Results (Mode 1)	44
4.2.8 Test Results (Mode 2)	46
4.3 Transmit Power Measurement	48
4.3.1 Limits of Transmit Power Measurement	48
4.3.2 Test Setup	48
4.3.3 Test Instruments	48
4.3.4 Test Procedure	48
4.3.5 Deviation from Test Standard	48
4.3.6 EUT Operating Condition	48
4.3.7 Test Result	49
4.4 Occupied Bandwidth Measurement	50
4.4.1 Test Setup	50
4.4.2 Test Instruments	50
4.4.3 Test Procedure	50
4.4.4 Test Results	51
4.5 Peak Power Spectral Density Measurement	55
4.5.1 Limits of Peak Power Spectral Density Measurement	55
4.5.2 Test Setup	55
4.5.3 Test Instruments	55
4.5.4 Test Procedure	56
4.5.5 Deviation from Test Standard	56
4.5.6 EUT Operating Condition	56
4.5.7 Test Results	57
4.6 Frequency Stability Measurement	63

4.6.1	Limits of Frequency Stability Measurement	63
4.6.2	Test Setup.....	63
4.6.3	Test Instruments	63
4.6.4	Test Procedure	63
4.6.5	Deviation from Test Standard	63
4.6.6	EUT Operating Condition	63
4.6.7	Test Results	64
4.7	6dB Bandwidth Measurement	65
4.7.1	Limits of 6dB Bandwidth Measurement.....	65
4.7.2	Test Setup.....	65
4.7.3	Test Instruments	65
4.7.4	Test Procedure	65
4.7.5	Deviation from Test Standard	65
4.7.6	EUT Operating Condition	65
4.7.7	Test Results	66
5	Pictures of Test Arrangements.....	68
	Annex A- Radiated Out of Band Emission (OOBE) Measurement (For U-NII-3 band)	69
	Appendix – Information on the Testing Laboratories	72

Release Control Record

Issue No.	Description	Date Issued
RF170209C07-1	Original release.	Mar. 29, 2016

1 Certificate of Conformity

Product: WiCS-2100

Brand: wePresent

Test Model: WiCS-2100

Sample Status: ENGINEERING SAMPLE

Applicant: Barco NV

Test Date: Mar. 03 to 16, 2017

Standard: 47 CFR FCC Part 15, Subpart E (Section 15.407)
ANSI C63.10: 2013

The above equipment has been tested by **Bureau Veritas Consumer Products Services (H.K.) Ltd., Taoyuan Branch**, and found compliance with the requirement of the above standards. The test record, data evaluation & Equipment Under Test (EUT) configurations represented herein are true and accurate accounts of the measurements of the sample's EMC characteristics under the conditions specified in this report.

Prepared by : Wendy Wu , **Date:** Mar. 29, 2016
Wendy Wu / Specialist

Approved by : May Chen , **Date:** Mar. 29, 2016
May Chen / Manager

2 Summary of Test Results

47 CFR FCC Part 15, Subpart E (Section 15.407)			
FCC Clause	Test Item	Result	Remarks
15.407(b)(6)	AC Power Conducted Emissions	Pass	Meet the requirement of limit. Minimum passing margin is -5.60dB at 0.38438MHz.
15.407(b) (1/2/3/4(i/ii)/6)	Radiated Emissions & Band Edge Measurement*	Pass	Meet the requirement of limit. Minimum passing margin is -0.1dB at 5150.00MHz.
15.407(a)(1/2/3)	Max Average Transmit Power	Pass	Meet the requirement of limit.
---	Occupied Bandwidth Measurement	-	Reference only.
15.407(a)(1/2/3)	Peak Power Spectral Density	Pass	Meet the requirement of limit.
15.407(e)	6dB bandwidth	Pass	Meet the requirement of limit. (U-NII-3 Band only)
15.407(g)	Frequency Stability	Pass	Meet the requirement of limit.
15.203	Antenna Requirement	Pass	No antenna connector is used

*For U-NII-3 band compliance with rule part 15.407(b)(4)(i), the OOB test plots were recorded in Annex A.

2.1 Measurement Uncertainty

Where relevant, the following measurement uncertainty levels have been estimated for tests performed on the EUT as specified in CISPR 16-4-2:

Measurement	Frequency	Expanded Uncertainty (k=2) (\pm)
Conducted Emissions at mains ports	150kHz ~ 30MHz	1.84 dB
Radiated Emissions up to 1 GHz	30MHz ~ 1GHz	5.34 dB
Radiated Emissions above 1 GHz	1GHz ~ 6GHz	3.41 dB
	6GHz ~ 18GHz	3.49 dB
	18GHz ~ 40GHz	3.30 dB

2.2 Modification Record

There were no modifications required for compliance.

3 General Information

3.1 General Description of EUT

Product	WiCS-2100
Brand	wePresent
Test Model	WiCS-2100
Status of EUT	ENGINEERING SAMPLE
Power Supply Rating	12Vdc from power adapter or 48Vdc from POE
Modulation Type	CCK, DQPSK, DBPSK for DSSS 64QAM, 16QAM, QPSK, BPSK for OFDM 256QAM for OFDM in 11ac mode only
Modulation Technology	DSSS, OFDM
Transfer Rate	802.11b: up to 11Mbps 802.11a/g: up to 54Mbps 802.11n: up to 300Mbps 802.11ac: up to 866.7Mbps
Operating Frequency	2.4GHz: 2.412 ~ 2.462GHz 5GHz: 5.18 ~ 5.24GHz, 5.745 ~ 5.825GHz
Number of Channel	2.4GHz: 802.11b, 802.11g, 802.11n (HT20): 11 802.11n (HT40): 7 5GHz: 802.11a, 802.11n (HT20), 802.11ac (VHT20): 9 802.11n (HT40), 802.11ac (VHT40): 4 802.11ac (VHT80): 2
Output Power	2.4GHz: 793.232mW 5.18 ~ 5.24GHz: 123.749mW 5.745 ~ 5.825GHz: 149.142mW
Antenna Type	Refer to Note
Antenna Connector	Refer to Note
Accessory Device	Adapter x 1, USB dongle x 1
Data Cable Supplied	NA

Note:

1. Simultaneously transmission condition.

Condition	Technology	
1	WLAN 2.4GHz	Bluetooth
2	WLAN 5GHz	Bluetooth

Note: The emission of the simultaneous operation has been evaluated and no non-compliance was found.

2. The EUT must be supplied with a power adapter or POE as following table:

Adapter		
Brand	Model No.	Spec.
APD	WA-24Q12R	Input: 100-240Vac, 0.7A, 50-60Hz Output: 12V, 2A DC output cable(unshielded, 1.5m)
POE (only for test, ont for sale)		
Brand	Model No.	Spec.
PowerDsine	PD-3501G/AC	48Vdc

Note: From the above adapter and POE, the worst radiated test was found in **Adapter**. Therefore only the test data of the modes were recorded in this report.

3. The USB dongle is provided for the EUT as following table:

Brand	Model No.
wePresent	MH301

4. The antennas provided to the EUT, please refer to the following table:

For 2.4GHz & BT					
Antenna No.	Brand	Model	Antenna Net. Gain(dBi)	Frequency range (GHz)	Antenna Type
1 (Main-WLAN+BT combo Ant)	Pegatron Corp.	Pegatron P/N: 1415- 05VU000 (Hong-Bo P/N: 290- 30536)	2.85	2.4~2.4835	PCB
2 (Aux-WLAN Ant)			1.76	2.4~2.4835	
For 5GHz					
Antenna No.	Brand	Model	Antenna Net. Gain(dBi)	Frequency range (GHz)	Antenna Type
1 (Main-WLAN Ant)	Pegatron Corp.	Pegatron P/N: 1415- 05VU000 (Hong-Bo P/N: 290- 30536)	2.58	5.15~5.25	PCB
			3.37	5.25~5.35	
			3.68	5.47~5.725	
			3.58	5.725~5850	
2 (Aux-WLAN Ant)	Pegatron Corp.	Pegatron P/N: 1415-05VT000 (Hong-Bo P/N: 290- 30535)	2.76	5.15~5.25	PCB
			3.4	5.25~5.35	
			3.26	5.47~5.725	
			2.07	5.725~5850	

5. The EUT incorporates a MIMO function.

2.4GHz Band		
MODULATION MODE	DATA RATE (MCS)	TX & RX CONFIGURATION
802.11b	1 ~ 11Mbps	2TX 2RX
802.11g	6 ~ 54Mbps	2TX 2RX
802.11n (HT20)	MCS 0~7	2TX 2RX
	MCS 8~15	2TX 2RX
802.11n (HT40)	MCS 0~7	2TX 2RX
	MCS 8~15	2TX 2RX
5GHz Band		
MODULATION MODE	DATA RATE (MCS)	TX & RX CONFIGURATION
802.11a	6 ~ 54Mbps	2TX 2RX
802.11n (HT20)	MCS 0~7	2TX 2RX
	MCS 8~15	2TX 2RX
802.11n (HT40)	MCS 0~7	2TX 2RX
	MCS 8~15	2TX 2RX
802.11ac (VHT20)	MCS0~8 Nss=1	2TX 2RX
	MCS0~8 Nss=2	2TX 2RX
802.11ac (VHT40)	MCS0~9 Nss=1	2TX 2RX
	MCS0~9 Nss=2	2TX 2RX
802.11ac (VHT80)	MCS0~9 Nss=1	2TX 2RX
	MCS0~9 Nss=2	2TX 2RX

Note: The modulation and bandwidth are similar for 802.11n mode for 20MHz (40MHz) and 802.11ac mode for 20MHz (40MHz), therefore investigated worst case to representative mode in test report. (Final test mode refer section 3.2.1)

6. The above EUT information is declared by manufacturer and for more detailed features description, please refer to the manufacturer's specifications or user's manual.

3.2 Description of Test Modes

FOR 5180 ~ 5240MHz

4 channels are provided for 802.11a, 802.11n (HT20), 802.11ac (VHT20):

Channel	Frequency	Channel	Frequency
36	5180 MHz	44	5220 MHz
40	5200 MHz	48	5240 MHz

2 channels are provided for 802.11n (HT40), 802.11ac (VHT40):

Channel	Frequency	Channel	Frequency
38	5190 MHz	46	5230 MHz

1 channel is provided for 802.11ac (VHT80):

Channel	Frequency
42	5210MHz

FOR 5745 ~ 5825MHz:

5 channels are provided for 802.11a, 802.11n (HT20), 802.11ac (VHT20):

Channel	Frequency	Channel	Frequency
149	5745MHz	161	5805MHz
153	5765MHz	165	5825MHz
157	5785MHz		

2 channels are provided for 802.11n (HT40), 802.11ac (VHT40):

Channel	Frequency	Channel	Frequency
151	5755MHz	159	5795MHz

1 channel is provided for 802.11ac (VHT80):

Channel	Frequency
155	5775MHz

3.2.1 Test Mode Applicability and Tested Channel Detail

EUT Configure Mode	Applicable To				Description
	RE \geq 1G	RE<1G	PLC	APCM	
1	√	√	√	√	With adapter
2	-	-	√	-	With POE

Where **RE \geq 1G**: Radiated Emission above 1GHz **RE<1G**: Radiated Emission below 1GHz
PLC: Power Line Conducted Emission **APCM**: Antenna Port Conducted Measurement

NOTE:

1. The EUT had been pre-tested on the positioned of each 2 axis. The worst case was found when positioned on **X-plane**.

Radiated Emission Test (Above 1GHz):

- Pre-Scan has been conducted to determine the worst-case mode from all possible combinations between available modulations, data rates and antenna ports (if EUT with antenna diversity architecture).
- Following channel(s) was (were) selected for the final test as listed below.

Mode	FREQ. Band (MHz)	Available Channel	Tested Channel	Modulation Technology	Modulation Type	Data Rate (Mbps)
802.11a	5180-5240	36 to 48	36, 40, 48	OFDM	BPSK	6
802.11ac (VHT20)		36 to 48	36, 40, 48	OFDM	BPSK	6.5
802.11ac (VHT40)		38 to 46	38, 46	OFDM	BPSK	13.5
802.11ac (VHT80)		42	42	OFDM	BPSK	29.3
802.11a	5745-5825	149 to 165	149, 157, 165	OFDM	BPSK	6
802.11ac (VHT20)		149 to 165	149, 157, 165	OFDM	BPSK	6.5
802.11ac (VHT40)		151 to 159	151, 159	OFDM	BPSK	13.5
802.11ac (VHT80)		155	155	OFDM	BPSK	29.3

Radiated Emission Test (Below 1GHz):

- Pre-Scan has been conducted to determine the worst-case mode from all possible combinations between available modulations, data rates and antenna ports (if EUT with antenna diversity architecture).
- Following channel(s) was (were) selected for the final test as listed below.

Mode	FREQ. Band (MHz)	Available Channel	Tested Channel	Modulation Technology	Modulation Type	Data Rate (Mbps)
802.11ac (VHT20)	5180-5240 5745-5825	36 to 48 149 to 165	157	OFDM	BPSK	6.5

Power Line Conducted Emission Test:

- Pre-Scan has been conducted to determine the worst-case mode from all possible combinations between available modulations, data rates and antenna ports (if EUT with antenna diversity architecture).
- Following channel(s) was (were) selected for the final test as listed below.

Mode	FREQ. Band (MHz)	Available Channel	Tested Channel	Modulation Technology	Modulation Type	Data Rate (Mbps)
802.11ac (VHT20)	5180-5240 5745-5825	36 to 48 149 to 165	157	OFDM	BPSK	6.5

Antenna Port Conducted Measurement:

- This item includes all test value of each mode, but only includes spectrum plot of worst value of each mode.
- Pre-Scan has been conducted to determine the worst-case mode from all possible combinations between available modulations, data rates and antenna ports (if EUT with antenna diversity architecture).
- Following channel(s) was (were) selected for the final test as listed below.

Mode	FREQ. Band (MHz)	Available Channel	Tested Channel	Modulation Technology	Modulation Type	Data Rate (Mbps)
802.11a	5180-5240	36 to 48	36, 40, 48	OFDM	BPSK	6
802.11ac (VHT20)		36 to 48	36, 40, 48	OFDM	BPSK	6.5
802.11ac (VHT40)		38 to 46	38, 46	OFDM	BPSK	13.5
802.11ac (VHT80)		42	42	OFDM	BPSK	29.3
802.11a	5745-5825	149 to 165	149, 157, 165	OFDM	BPSK	6
802.11ac (VHT20)		149 to 165	149, 157, 165	OFDM	BPSK	6.5
802.11ac (VHT40)		151 to 159	151, 159	OFDM	BPSK	13.5
802.11ac (VHT80)		155	155	OFDM	BPSK	29.3

Test Condition:

Applicable To	Environmental Conditions	Input Power	Tested By
RE \geq 1G	23deg. C, 66%RH	120Vac, 60Hz	Weiwei Lo
RE $<$ 1G	23deg. C, 66%RH	120Vac, 60Hz	Terry Huang
PLC	25deg. C, 75%RH	120Vac, 60Hz	Andy Ho
APCM	25deg. C, 60%RH	120Vac, 60Hz	Anderson Chen

3.3 Duty Cycle of Test Signal

If duty cycle of test signal is $\geq 98\%$, duty factor is not required.

If duty cycle of test signal is $< 98\%$, duty factor shall be considered.

802.11a: Duty cycle = $21.412 \text{ ms} / 21.537 \text{ ms} = 0.994$

802.11ac (VHT20): Duty cycle = $19.875 \text{ ms} / 19.994 \text{ ms} = 0.994$

802.11ac (VHT40): Duty cycle = $9.575 \text{ ms} / 9.7 \text{ ms} = 0.987$

802.11ac (VHT80): Duty cycle = $4.425 \text{ ms} / 4.52 \text{ ms} = 0.979$, Duty factor = $10 * \log(1/0.979) = 0.09$

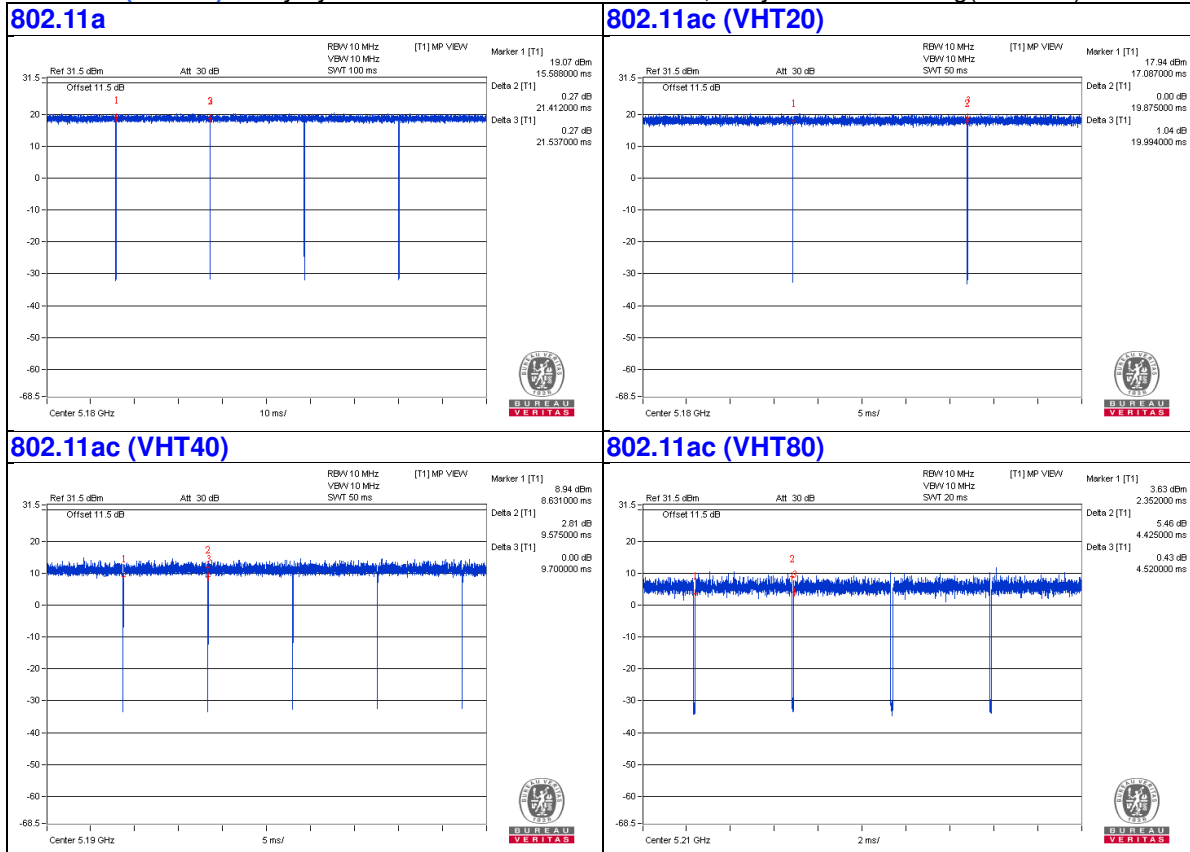

3.4 Description of Support Units

The EUT has been tested as an independent unit together with other necessary accessories or support units. The following support units or accessories were used to form a representative test configuration during the tests.

ID	Product	Brand	Model No.	Serial No.	FCC ID	Remarks
A.	Laptop	DELL	E5430	HYV4VY1	FCC DoC	Provided by Lab
B.	Monitor	ASUS	VS247	NA	NA	Provided by Lab
C.	PoE Adapter	PowerDsine	PD-3501G/AC	NA	NA	Provided by Lab
D.	Mouse	DELL	MS111-P	NA	NA	Provided by Lab

Note:

1. All power cords of the above support units are non-shielded (1.8m).

ID	Descriptions	Qty.	Length (m)	Shielding (Yes/No)	Cores (Qty.)	Remarks
1.	DC Cable	1	1.5	No	0	Supplied by client
2.	RJ-45 Cable	1	10	No	0	Provided by Lab
3.	Audio Cable	1	1.8	No	0	Provided by Lab
4.	HDMI Cable	1	3	Yes	0	Provided by Lab
5.	AC Cable	1	1.8	No	0	Provided by Lab
6.	RJ-45 Cable	1	3	No	0	Provided by Lab
7.	USB Cable	1	1.8	Yes	0	Provided by Lab

3.4.1 Configuration of System under Test

Mode 1:

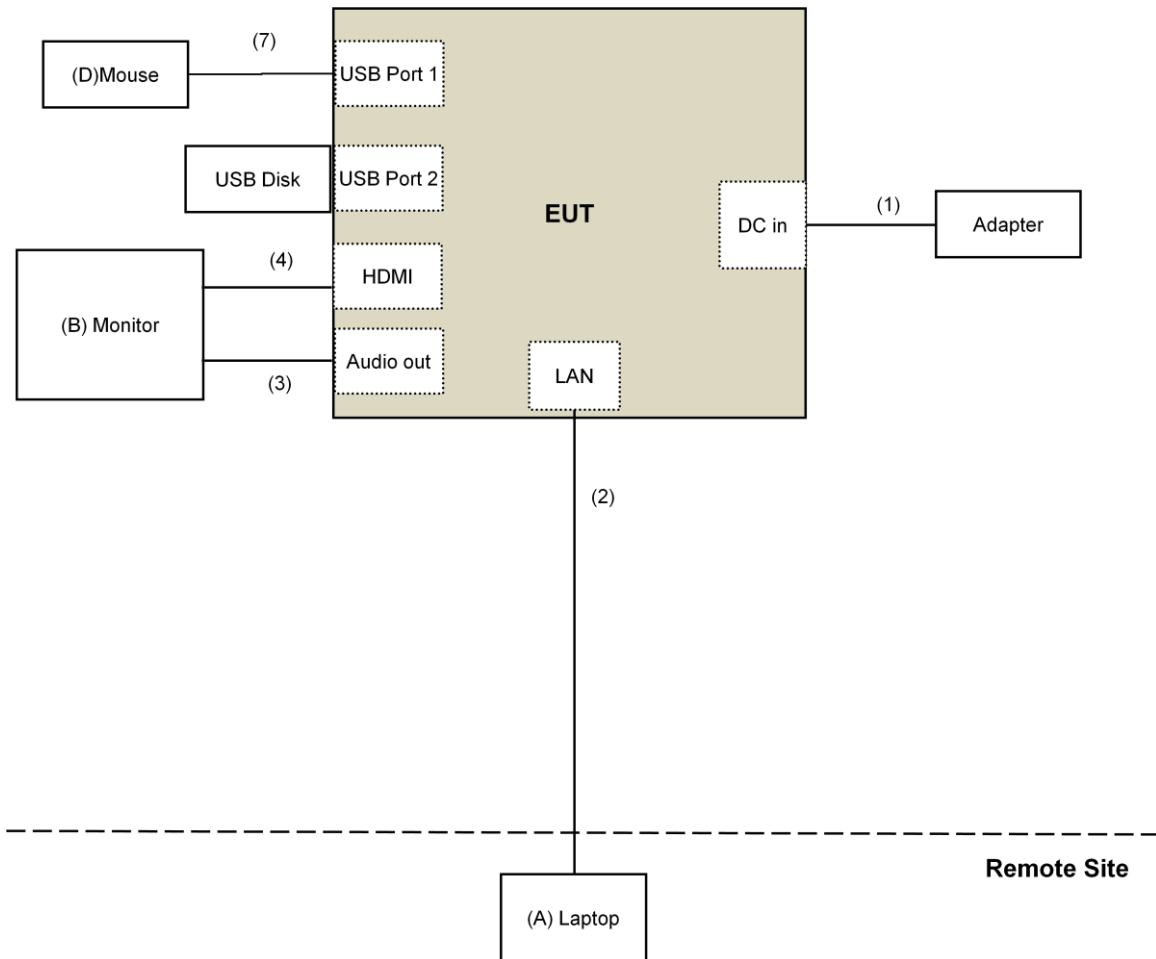

Mode 2:

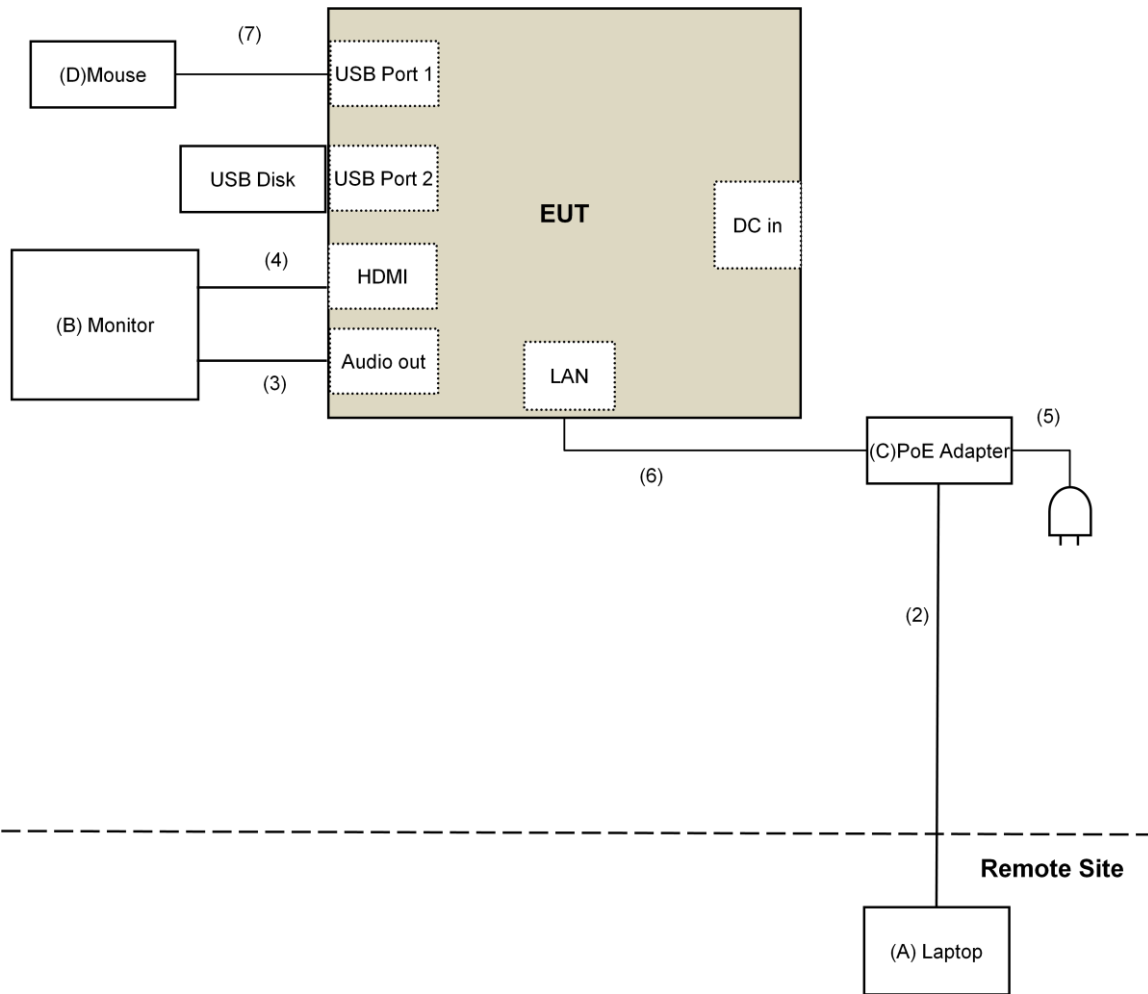

3.5 General Description of Applied Standard

The EUT is a RF Product. According to the specifications of the manufacturer, it must comply with the requirements of the following standards:

FCC Part 15, Subpart E (15.407)
KDB 789033 D02 General UNII Test Procedure New Rules v01r03
KDB 662911 D01 Multiple Transmitter Output v02r01
ANSI C63.10-2013

All test items have been performed and recorded as per the above standards.

NOTE: The EUT has been verified to comply with the requirements of FCC Part 15, Subpart B, Class B (DoC). The test report has been issued separately.

4 Test Types and Results

4.1 Radiated Emission and Bandedge Measurement

4.1.1 Limits of Radiated Emission and Bandedge Measurement

Radiated emissions which fall in the restricted bands must comply with the radiated emission limits specified as below table.

Frequencies (MHz)	Field Strength (microvolts/meter)	Measurement Distance (meters)
0.009 ~ 0.490	2400/F(kHz)	300
0.490 ~ 1.705	24000/F(kHz)	30
1.705 ~ 30.0	30	30
30 ~ 88	100	3
88 ~ 216	150	3
216 ~ 960	200	3
Above 960	500	3

NOTE:

1. The lower limit shall apply at the transition frequencies.
2. Emission level (dBuV/m) = 20 log Emission level (uV/m).
3. For frequencies above 1000MHz, the field strength limits are based on average detector, however, the peak field strength of any emission shall not exceed the maximum permitted average limits, specified above by more than 20dB under any condition of modulation.

Limits of unwanted emission out of the restricted bands

Applicable To		Limit	
789033 D02 General UNII Test Procedure New Rules v01r03		Field Strength at 3m	
		PK:74 (dBμV/m)	AV:54 (dBμV/m)
Frequency Band	Applicable To	EIRP Limit	Equivalent Field Strength at 3m
5150~5250 MHz	15.407(b)(1)	PK:-27 (dBm/MHz)	PK:68.2(dBμV/m)
5250~5350 MHz	15.407(b)(2)		
5470~5725 MHz	15.407(b)(3)		
5725~5850 MHz	<input checked="" type="checkbox"/> 15.407(b)(4)(i)	PK:-27 (dBm/MHz) ^{*1} PK:10 (dBm/MHz) ^{*2} PK:15.6 (dBm/MHz) ^{*3} PK:27 (dBm/MHz) ^{*4}	PK: 68.2(dBμV/m) ^{*1} PK:105.2 (dBμV/m) ^{*2} PK: 110.8(dBμV/m) ^{*3} PK:122.2 (dBμV/m) ^{*4}
	<input type="checkbox"/> 15.407(b)(4)(ii)	Emission limits in section 15.247(d)	
^{*1} beyond 75 MHz or more above of the band edge.		^{*2} below the band edge increasing linearly to 10 dBm/MHz at 25 MHz above.	
^{*3} below the band edge increasing linearly to a level of 15.6 dBm/MHz at 5 MHz above.		^{*4} from 5 MHz above or below the band edge increasing linearly to a level of 27 dBm/MHz at the band edge.	

Note:

The following formula is used to convert the equipment isotropic radiated power (eirp) to field strength:

$$E = \frac{1000000\sqrt{30P}}{3} \mu\text{V/m, where P is the eirp (Watts).}$$

4.1.2 Test Instruments

DESCRIPTION & MANUFACTURER	MODEL NO.	SERIAL NO.	CALIBRATED DATE	CALIBRATED UNTIL
Test Receiver Keysight	N9038A	MY54450088	July 20, 2016	July 19, 2017
Pre-Amplifier ^(*) EMCI	EMC001340	980142	Jan. 20, 2016	Jan. 19, 2018
Loop Antenna ^(*) Electro-Metrics	EM-6879	264	Dec. 16, 2016	Dec. 15, 2018
RF Cable	NA	LOOPCAB-001 LOOPCAB-002	Jan. 17, 2017	Jan. 16, 2018
Pre-Amplifier Mini-Circuits	ZFL-1000VH2B	AMP-ZFL-01	Nov. 10, 2016	Nov. 09, 2017
Trilog Broadband Antenna SCHWARZBECK	VULB 9168	9168-406	Dec. 13, 2016	Dec. 12, 2017
RF Cable	8D	966-4-1 966-4-2 966-4-3	Apr. 02, 2016	Apr. 01, 2017
Fixed attenuator Mini-Circuits	UNAT-5+	PAD-3m-4-01	Oct. 05, 2016	Oct. 04, 2017
Horn_Antenna SCHWARZBECK	BBHA 9120D	9120D-783	Dec. 27, 2016	Dec. 26, 2017
Pre-Amplifier EMCI	EMC12630SE	980385	Feb. 02, 2017	Feb. 01, 2018
RF Cable	EMC104-SM-SM-2000 EMC104-SM-SM-5000 EMC104-SM-SM-5000	160923 150318 150323	Feb. 02, 2017 Mar. 30, 2016 Mar. 30, 2016	Feb. 01, 2018 Mar. 29, 2017 Mar. 29, 2017
Pre-Amplifier EMCI	EMC184045SE	980387	Feb. 02, 2017	Feb. 01, 2018
Horn_Antenna SCHWARZBECK	BBHA 9170	BBHA9170608	Dec. 15, 2016	Dec. 14, 2017
RF Cable	SUCOFLEX 102	36432/2 36433/2	Jan. 15, 2017	Jan. 14, 2018
Software	ADT_Radiated_V8.7.08	NA	NA	NA
Antenna Tower & Turn Table Max-Full	MF-7802	MF780208410	NA	NA
Boresight Antenna Fixture	FBA-01	FBA-SIP02	NA	NA
Spectrum Analyzer R&S	FSV40	100964	June 28, 2016	June 27, 2017
Power meter Anritsu	ML2495A	1014008	May 5, 2016	May 4, 2017
Power sensor Anritsu	MA2411B	0917122	May 5, 2016	May 4, 2017
AC Power Source Extech Electronics	6205	1440452	NA	NA
Temperature & Humidity Chamber Giant Force	GTH-150-40-SP-AR	MAA0812-008	Jan. 11, 2017	Jan. 10, 2018
Digital Multimeter FLUKE	87III	73680266	Nov. 10, 2016	Nov. 09, 2017

Note:

1. The calibration interval of the above test instruments is 12 months and the calibrations are traceable to NML/ROC and NIST/USA.
2. *The calibration interval of the above test instruments is 24 months and the calibrations are traceable to NML/ROC and NIST/USA.
3. The test was performed in 966 Chamber No. 4.
4. The FCC Site Registration No. is 292998
5. The CANADA Site Registration No. is 20331-2
- 6 Loop antenna was used for all emissions below 30 MHz.
7. Tested Date: Mar. 08 to 09, 2017

4.1.3 Test Procedure

For Radiated emission below 30MHz

- a. The EUT was placed on the top of a rotating table 0.8 meters above the ground at a 3 meter chamber room. The table was rotated 360 degrees to determine the position of the highest radiation.
- b. The EUT was set 3 meters away from the interference-receiving antenna, which was mounted on the top of a variable-height antenna tower.
- c. Both X and Y axes of the antenna are set to make the measurement.
- d. For each suspected emission, the EUT was arranged to its worst case and the rotatable table was turned from 0 degrees to 360 degrees to find the maximum reading.
- e. The test-receiver system was set to Quasi-Peak Detect Function and Specified Bandwidth with Maximum Hold Mode.

NOTE:

1. The resolution bandwidth and video bandwidth of test receiver/spectrum analyzer is 9kHz at frequency below 30MHz.

For Radiated emission above 30MHz

- a. The EUT was placed on the top of a rotating table 0.8 meters (for 30MHz ~ 1GHz) / 1.5 meters (for above 1GHz) above the ground at 3 meter chamber room for test. The table was rotated 360 degrees to determine the position of the highest radiation.
- b. The EUT was set 3 meters away from the interference-receiving antenna, which was mounted on the top of a variable-height antenna tower.
- c. The height of antenna is varied from one meter to four meters above the ground to determine the maximum value of the field strength. Both horizontal and vertical polarizations of the antenna are set to make the measurement.
- d. For each suspected emission, the EUT was arranged to its worst case and then the antenna was tuned to heights from 1 meter to 4 meters and the rotatable table was turned from 0 degrees to 360 degrees to find the maximum reading.
- e. The test-receiver system was set to quasi-peak detect function and specified bandwidth with maximum hold mode when the test frequency is below 1 GHz.
- f. The test-receiver system was set to peak and average detect function and specified bandwidth with maximum hold mode when the test frequency is above 1 GHz. If the peak reading value also meets average limit, measurement with the average detector is unnecessary.

Note:

1. The resolution bandwidth and video bandwidth of test receiver/spectrum analyzer is 120kHz for Quasi-peak detection (QP) at frequency below 1GHz.
2. The resolution bandwidth of test receiver/spectrum analyzer is 1 MHz and the video bandwidth is 3 MHz for Peak detection (PK) at frequency above 1GHz.
3. The resolution bandwidth of test receiver/spectrum analyzer is 1MHz and the video bandwidth is $\geq 1/T$ (Duty cycle < 98%) or 10Hz (Duty cycle $\geq 98\%$) for Average detection (AV) at frequency above 1GHz.
4. All modes of operation were investigated and the worst-case emissions are reported.

4.1.4 Deviation from Test Standard

No deviation.

4.1.5 Test Setup

For Radiated emission below 30MHz

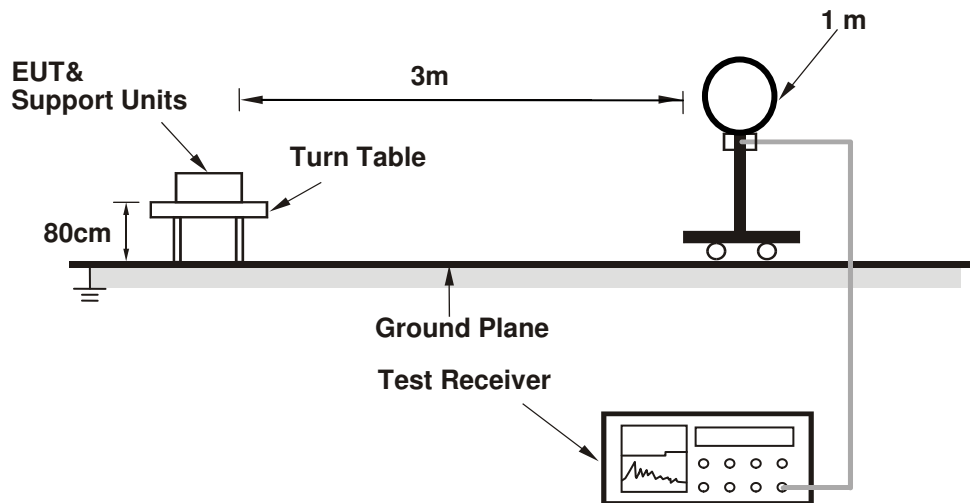

For Radiated emission 30MHz to 1GHz

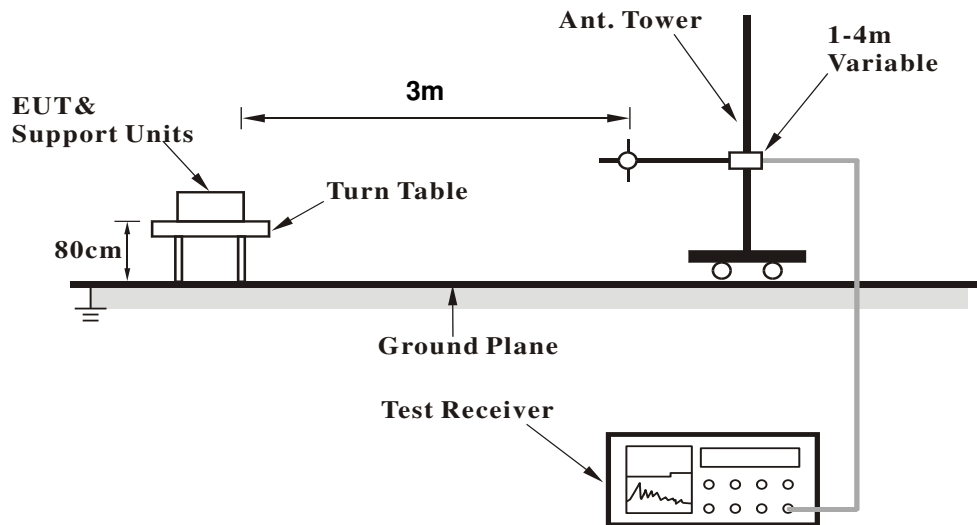

For Radiated emission above 1GHz

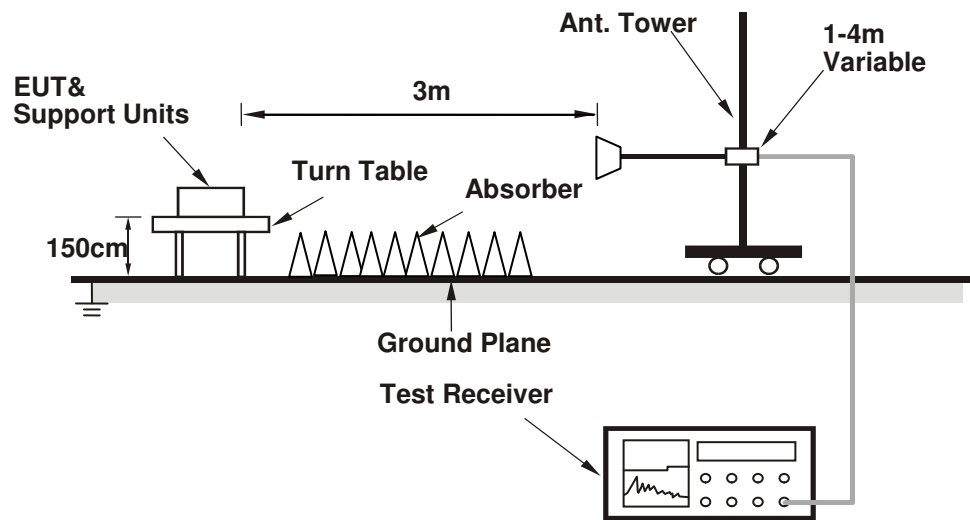

For the actual test configuration, please refer to the attached file (Test Setup Photo).

4.1.6 EUT Operating Condition

- a. Connected the EUT with the Laptop which is placed on remote site.
- b. Controlling software (QRCT.EXE v3.0.197.0) has been activated to set the EUT on specific status.

4.1.7 Test Results

Above 1GHz Data:

802.11a

CHANNEL	TX Channel 36	DETECTOR FUNCTION	Peak (PK)
FREQUENCY RANGE	1GHz ~ 40GHz		Average (AV)

ANTENNA POLARITY & TEST DISTANCE: HORIZONTAL AT 3 M

NO.	FREQ. (MHz)	EMISSION LEVEL (dBuV/m)	LIMIT (dBuV/m)	MARGIN (dB)	ANTENNA HEIGHT (m)	TABLE ANGLE (Degree)	RAW VALUE (dBuV)	CORRECTION FACTOR (dB/m)
1	5150.00	61.5 PK	74.0	-12.5	1.50 H	300	58.6	2.9
2	5150.00	51.3 AV	54.0	-2.7	1.50 H	300	48.4	2.9
3	*5180.00	107.3 PK			1.50 H	300	104.3	3.0
4	*5180.00	97.3 AV			1.50 H	300	94.3	3.0
5	#10360.00	58.3 PK	74.0	-15.7	1.39 H	139	46.2	12.1
6	#10360.00	47.4 AV	54.0	-6.6	1.39 H	139	35.3	12.1
7	15540.00	49.5 PK	74.0	-24.5	1.00 H	96	37.6	11.9
8	15540.00	37.4 AV	54.0	-16.6	1.00 H	96	25.5	11.9

ANTENNA POLARITY & TEST DISTANCE: VERTICAL AT 3 M

NO.	FREQ. (MHz)	EMISSION LEVEL (dBuV/m)	LIMIT (dBuV/m)	MARGIN (dB)	ANTENNA HEIGHT (m)	TABLE ANGLE (Degree)	RAW VALUE (dBuV)	CORRECTION FACTOR (dB/m)
1	5150.00	64.4 PK	74.0	-9.6	1.05 V	300	61.5	2.9
2	5150.00	53.9 AV	54.0	-0.1	1.05 V	300	51.0	2.9
3	*5180.00	111.1 PK			1.05 V	300	108.1	3.0
4	*5180.00	101.7 AV			1.05 V	300	98.7	3.0
5	#10360.00	67.7 PK	74.0	-6.3	1.00 V	204	55.6	12.1
6	#10360.00	53.2 AV	54.0	-0.8	1.00 V	204	41.1	12.1
7	15540.00	53.1 PK	74.0	-20.9	1.34 V	118	41.2	11.9
8	15540.00	41.1 AV	54.0	-12.9	1.34 V	118	29.2	11.9

REMARKS:

1. Emission Level(dBuV/m) = Raw Value(dBuV) + Correction Factor(dB/m)
2. Correction Factor(dB/m) = Antenna Factor(dB/m) + Cable Factor(dB) – Pre-Amplifier Factor(dB)
3. The other emission levels were very low against the limit.
4. Margin value = Emission Level – Limit value
5. " * ": Fundamental frequency.
6. " # ": The radiated frequency is out of the restricted band.

CHANNEL	TX Channel 40	DETECTOR FUNCTION	Peak (PK)
FREQUENCY RANGE	1GHz ~ 40GHz		Average (AV)

ANTENNA POLARITY & TEST DISTANCE: HORIZONTAL AT 3 M

NO.	FREQ. (MHz)	EMISSION LEVEL (dBuV/m)	LIMIT (dBuV/m)	MARGIN (dB)	ANTENNA HEIGHT (m)	TABLE ANGLE (Degree)	RAW VALUE (dBuV)	CORRECTION FACTOR (dB/m)
1	5150.00	64.7 PK	74.0	-9.3	1.50 H	294	61.8	2.9
2	5150.00	50.1 AV	54.0	-3.9	1.50 H	294	47.2	2.9
3	*5200.00	109.7 PK			1.50 H	294	106.7	3.0
4	*5200.00	99.5 AV			1.50 H	294	96.5	3.0
5	#10400.00	58.7 PK	74.0	-15.3	1.37 H	152	46.7	12.0
6	#10400.00	47.8 AV	54.0	-6.2	1.37 H	152	35.8	12.0
7	15600.00	48.2 PK	74.0	-25.8	1.00 H	88	36.1	12.1
8	15600.00	36.3 AV	54.0	-17.7	1.00 H	88	24.2	12.1

ANTENNA POLARITY & TEST DISTANCE: VERTICAL AT 3 M

NO.	FREQ. (MHz)	EMISSION LEVEL (dBuV/m)	LIMIT (dBuV/m)	MARGIN (dB)	ANTENNA HEIGHT (m)	TABLE ANGLE (Degree)	RAW VALUE (dBuV)	CORRECTION FACTOR (dB/m)
1	5150.00	67.8 PK	74.0	-6.2	1.23 V	301	64.9	2.9
2	5150.00	52.9 AV	54.0	-1.1	1.23 V	301	50.0	2.9
3	*5200.00	113.7 PK			1.23 V	301	110.7	3.0
4	*5200.00	103.8 AV			1.23 V	301	100.8	3.0
5	#10400.00	68.1 PK	74.0	-5.9	1.13 V	205	56.1	12.0
6	#10400.00	53.5 AV	54.0	-0.5	1.13 V	205	41.5	12.0
7	15600.00	49.1 PK	74.0	-24.9	1.00 V	255	37.0	12.1
8	15600.00	37.7 AV	54.0	-16.3	1.00 V	255	25.6	12.1

REMARKS:

1. Emission Level(dBuV/m) = Raw Value(dBuV) + Correction Factor(dB/m)
2. Correction Factor(dB/m) = Antenna Factor(dB/m) + Cable Factor(dB) – Pre-Amplifier Factor(dB)
3. The other emission levels were very low against the limit.
4. Margin value = Emission Level – Limit value
5. " * ": Fundamental frequency.
6. " # ": The radiated frequency is out of the restricted band.

CHANNEL	TX Channel 48	DETECTOR FUNCTION	Peak (PK)
FREQUENCY RANGE	1GHz ~ 40GHz		Average (AV)

ANTENNA POLARITY & TEST DISTANCE: HORIZONTAL AT 3 M

NO.	FREQ. (MHz)	EMISSION LEVEL (dBuV/m)	LIMIT (dBuV/m)	MARGIN (dB)	ANTENNA HEIGHT (m)	TABLE ANGLE (Degree)	RAW VALUE (dBuV)	CORRECTION FACTOR (dB/m)
1	*5240.00	108.6 PK			1.48 H	287	105.4	3.2
2	*5240.00	98.3 AV			1.48 H	287	95.1	3.2
3	5350.00	46.4 PK	74.0	-27.6	1.48 H	287	43.0	3.4
4	5350.00	34.8 AV	54.0	-19.2	1.48 H	287	31.4	3.4
5	#10480.00	58.5 PK	74.0	-15.5	1.39 H	151	46.3	12.2
6	#10480.00	47.8 AV	54.0	-6.2	1.39 H	151	35.6	12.2
7	15720.00	51.3 PK	74.0	-22.7	1.00 H	86	38.4	12.9
8	15720.00	39.8 AV	54.0	-14.2	1.00 H	86	26.9	12.9

ANTENNA POLARITY & TEST DISTANCE: VERTICAL AT 3 M

NO.	FREQ. (MHz)	EMISSION LEVEL (dBuV/m)	LIMIT (dBuV/m)	MARGIN (dB)	ANTENNA HEIGHT (m)	TABLE ANGLE (Degree)	RAW VALUE (dBuV)	CORRECTION FACTOR (dB/m)
1	*5240.00	112.0 PK			1.02 V	252	108.8	3.2
2	*5240.00	102.5 AV			1.02 V	252	99.3	3.2
3	5350.00	49.1 PK	74.0	-24.9	1.02 V	252	45.7	3.4
4	5350.00	37.5 AV	54.0	-16.5	1.02 V	252	34.1	3.4
5	#10480.00	67.6 PK	74.0	-6.4	1.00 V	171	55.4	12.2
6	#10480.00	53.8 AV	54.0	-0.2	1.00 V	171	41.6	12.2
7	15720.00	53.4 PK	74.0	-20.6	1.35 V	110	40.5	12.9
8	15720.00	41.7 AV	54.0	-12.3	1.35 V	110	28.8	12.9

REMARKS:

1. Emission Level(dBuV/m) = Raw Value(dBuV) + Correction Factor(dB/m)
2. Correction Factor(dB/m) = Antenna Factor(dB/m) + Cable Factor(dB) – Pre-Amplifier Factor(dB)
3. The other emission levels were very low against the limit.
4. Margin value = Emission Level – Limit value
5. " * ": Fundamental frequency.
6. " # ": The radiated frequency is out of the restricted band.

CHANNEL	TX Channel 149	DETECTOR FUNCTION	Peak (PK)
FREQUENCY RANGE	1GHz ~ 40GHz		Average (AV)

ANTENNA POLARITY & TEST DISTANCE: HORIZONTAL AT 3 M

NO.	FREQ. (MHz)	EMISSION LEVEL (dBuV/m)	LIMIT (dBuV/m)	MARGIN (dB)	ANTENNA HEIGHT (m)	TABLE ANGLE (Degree)	RAW VALUE (dBuV)	CORRECTION FACTOR (dB/m)
1	#5611.70	58.3 PK	68.2	-9.9	1.26 H	274	54.6	3.7
2	*5745.00	110.0 PK			1.26 H	274	106.0	4.0
3	*5745.00	99.6 AV			1.26 H	274	95.6	4.0
4	#5968.83	57.9 PK	68.2	-10.3	1.26 H	274	53.4	4.5
5	7660.00	50.3 PK	74.0	-23.7	1.26 H	274	40.8	9.5
6	7660.00	47.8 AV	54.0	-6.2	1.26 H	274	38.3	9.5
7	11490.00	59.4 PK	74.0	-14.6	1.34 H	147	46.6	12.8
8	11490.00	47.9 AV	54.0	-6.1	1.34 H	147	35.1	12.8
9	#17235.00	48.1 PK	74.0	-25.9	1.00 H	58	30.7	17.4
10	#17235.00	36.5 AV	54.0	-17.5	1.00 H	58	19.1	17.4

ANTENNA POLARITY & TEST DISTANCE: VERTICAL AT 3 M

NO.	FREQ. (MHz)	EMISSION LEVEL (dBuV/m)	LIMIT (dBuV/m)	MARGIN (dB)	ANTENNA HEIGHT (m)	TABLE ANGLE (Degree)	RAW VALUE (dBuV)	CORRECTION FACTOR (dB/m)
1	#5560.12	58.2 PK	68.2	-10.0	1.00 V	277	54.6	3.6
2	*5745.00	113.4 PK			1.00 V	277	109.4	4.0
3	*5745.00	103.2 AV			1.00 V	277	99.2	4.0
4	#5929.75	58.0 PK	68.2	-10.2	1.00 V	277	53.7	4.3
5	7660.00	54.4 PK	74.0	-19.6	1.00 V	224	44.9	9.5
6	7660.00	52.5 AV	54.0	-1.5	1.00 V	224	43.0	9.5
7	11490.00	67.6 PK	74.0	-6.4	1.30 V	243	54.8	12.8
8	11490.00	51.2 AV	54.0	-2.8	1.30 V	243	38.4	12.8
9	#17235.00	53.3 PK	74.0	-20.7	1.35 V	112	35.9	17.4
10	#17235.00	41.8 AV	54.0	-12.2	1.35 V	112	24.4	17.4

REMARKS:

1. Emission Level(dBuV/m) = Raw Value(dBuV) + Correction Factor(dB/m)
2. Correction Factor(dB/m) = Antenna Factor(dB/m) + Cable Factor(dB) – Pre-Amplifier Factor(dB)
3. The other emission levels were very low against the limit.
4. Margin value = Emission Level – Limit value
5. " * ": Fundamental frequency.
6. " # ": The radiated frequency is out of the restricted band.

CHANNEL	TX Channel 157	DETECTOR FUNCTION	Peak (PK)
FREQUENCY RANGE	1GHz ~ 40GHz		Average (AV)

ANTENNA POLARITY & TEST DISTANCE: HORIZONTAL AT 3 M

NO.	FREQ. (MHz)	EMISSION LEVEL (dBuV/m)	LIMIT (dBuV/m)	MARGIN (dB)	ANTENNA HEIGHT (m)	TABLE ANGLE (Degree)	RAW VALUE (dBuV)	CORRECTION FACTOR (dB/m)
1	#5580.47	58.5 PK	68.2	-9.7	1.26 H	290	54.9	3.6
2	*5785.00	109.4 PK			1.26 H	290	105.4	4.0
3	*5785.00	99.2 AV			1.26 H	290	95.2	4.0
4	#5974.41	57.5 PK	68.2	-10.7	1.26 H	290	53.0	4.5
5	7713.00	51.1 PK	74.0	-22.9	1.26 H	290	41.5	9.6
6	7713.00	48.2 AV	54.0	-5.8	1.26 H	290	38.6	9.6
7	11570.00	58.3 PK	74.0	-15.7	1.30 H	141	45.7	12.6
8	11570.00	47.3 AV	54.0	-6.7	1.30 H	141	34.7	12.6
9	#17355.00	48.2 PK	74.0	-25.8	1.00 H	59	30.1	18.1
10	#17355.00	37.0 AV	54.0	-17.0	1.00 H	59	18.9	18.1

ANTENNA POLARITY & TEST DISTANCE: VERTICAL AT 3 M

NO.	FREQ. (MHz)	EMISSION LEVEL (dBuV/m)	LIMIT (dBuV/m)	MARGIN (dB)	ANTENNA HEIGHT (m)	TABLE ANGLE (Degree)	RAW VALUE (dBuV)	CORRECTION FACTOR (dB/m)
1	#5615.25	58.7 PK	68.2	-9.5	1.00 V	277	55.0	3.7
2	*5785.00	113.3 PK			1.00 V	277	109.3	4.0
3	*5785.00	103.4 AV			1.00 V	277	99.4	4.0
4	#5970.23	58.1 PK	68.2	-10.1	1.00 V	277	53.6	4.5
5	7713.00	55.7 PK	74.0	-18.3	1.00 V	226	46.1	9.6
6	7713.00	53.1 AV	54.0	-0.9	1.00 V	226	43.5	9.6
7	11570.00	67.8 PK	74.0	-6.2	1.28 V	229	55.2	12.6
8	11570.00	51.5 AV	54.0	-2.5	1.28 V	229	38.9	12.6
9	#17355.00	53.5 PK	74.0	-20.5	1.30 V	102	35.4	18.1
10	#17355.00	42.2 AV	54.0	-11.8	1.30 V	102	24.1	18.1

REMARKS:

1. Emission Level(dBuV/m) = Raw Value(dBuV) + Correction Factor(dB/m)
2. Correction Factor(dB/m) = Antenna Factor(dB/m) + Cable Factor(dB) – Pre-Amplifier Factor(dB)
3. The other emission levels were very low against the limit.
4. Margin value = Emission Level – Limit value
5. " * ": Fundamental frequency.
6. " # ": The radiated frequency is out of the restricted band.

CHANNEL	TX Channel 165	DETECTOR FUNCTION	Peak (PK)
FREQUENCY RANGE	1GHz ~ 40GHz		Average (AV)

ANTENNA POLARITY & TEST DISTANCE: HORIZONTAL AT 3 M

NO.	FREQ. (MHz)	EMISSION LEVEL (dBuV/m)	LIMIT (dBuV/m)	MARGIN (dB)	ANTENNA HEIGHT (m)	TABLE ANGLE (Degree)	RAW VALUE (dBuV)	CORRECTION FACTOR (dB/m)
1	#5641.84	59.1 PK	68.2	-9.1	1.24 H	281	55.3	3.8
2	*5825.00	110.6 PK			1.24 H	281	106.5	4.1
3	*5825.00	100.0 AV			1.24 H	281	95.9	4.1
4	#5968.63	58.1 PK	68.2	-10.1	1.24 H	281	53.6	4.5
5	11650.00	58.9 PK	74.0	-15.1	1.35 H	140	46.1	12.8
6	11650.00	47.7 AV	54.0	-6.3	1.35 H	140	34.9	12.8
7	#17475.00	48.7 PK	74.0	-25.3	1.00 H	62	29.9	18.8
8	#17475.00	37.2 AV	54.0	-16.8	1.00 H	62	18.4	18.8

ANTENNA POLARITY & TEST DISTANCE: VERTICAL AT 3 M

NO.	FREQ. (MHz)	EMISSION LEVEL (dBuV/m)	LIMIT (dBuV/m)	MARGIN (dB)	ANTENNA HEIGHT (m)	TABLE ANGLE (Degree)	RAW VALUE (dBuV)	CORRECTION FACTOR (dB/m)
1	#5552.94	57.7 PK	68.2	-10.5	1.00 V	280	54.2	3.5
2	*5825.00	113.2 PK			1.00 V	280	109.1	4.1
3	*5825.00	103.1 AV			1.00 V	280	99.0	4.1
4	#5958.44	58.3 PK	68.2	-9.9	1.00 V	280	53.9	4.4
5	11650.00	67.6 PK	74.0	-6.4	1.22 V	244	54.8	12.8
6	11650.00	50.2 AV	54.0	-3.8	1.22 V	244	37.4	12.8
7	#17475.00	52.8 PK	74.0	-21.2	1.37 V	113	34.0	18.8
8	#17475.00	41.6 AV	54.0	-12.4	1.37 V	113	22.8	18.8

REMARKS:

1. Emission Level(dBuV/m) = Raw Value(dBuV) + Correction Factor(dB/m)
2. Correction Factor(dB/m) = Antenna Factor(dB/m) + Cable Factor(dB) – Pre-Amplifier Factor(dB)
3. The other emission levels were very low against the limit.
4. Margin value = Emission Level – Limit value
5. " * ": Fundamental frequency.
6. " # ": The radiated frequency is out of the restricted band.

802.11ac (VHT20)

CHANNEL	TX Channel 36	DETECTOR FUNCTION	Peak (PK)
FREQUENCY RANGE	1GHz ~ 40GHz		Average (AV)

ANTENNA POLARITY & TEST DISTANCE: HORIZONTAL AT 3 M

NO.	FREQ. (MHz)	EMISSION LEVEL (dBuV/m)	LIMIT (dBuV/m)	MARGIN (dB)	ANTENNA HEIGHT (m)	TABLE ANGLE (Degree)	RAW VALUE (dBuV)	CORRECTION FACTOR (dB/m)
1	5150.00	63.5 PK	74.0	-10.5	1.50 H	300	60.6	2.9
2	5150.00	51.2 AV	54.0	-2.8	1.50 H	300	48.3	2.9
3	*5180.00	107.5 PK			1.50 H	300	104.5	3.0
4	*5180.00	97.3 AV			1.50 H	300	94.3	3.0
5	#10360.00	58.1 PK	74.0	-15.9	1.34 H	126	46.0	12.1
6	#10360.00	47.1 AV	54.0	-6.9	1.34 H	126	35.0	12.1
7	15540.00	47.5 PK	74.0	-26.5	1.00 H	52	35.6	11.9
8	15540.00	36.2 AV	54.0	-17.8	1.00 H	52	24.3	11.9

ANTENNA POLARITY & TEST DISTANCE: VERTICAL AT 3 M

NO.	FREQ. (MHz)	EMISSION LEVEL (dBuV/m)	LIMIT (dBuV/m)	MARGIN (dB)	ANTENNA HEIGHT (m)	TABLE ANGLE (Degree)	RAW VALUE (dBuV)	CORRECTION FACTOR (dB/m)
1	5150.00	66.1 PK	74.0	-7.9	1.08 V	300	63.2	2.9
2	5150.00	53.0 AV	54.0	-1.0	1.08 V	300	50.1	2.9
3	*5180.00	111.4 PK			1.08 V	300	108.4	3.0
4	*5180.00	101.5 AV			1.08 V	300	98.5	3.0
5	#10360.00	67.8 PK	74.0	-6.2	1.30 V	227	55.7	12.1
6	#10360.00	51.2 AV	54.0	-2.8	1.30 V	227	39.1	12.1
7	15540.00	50.0 PK	74.0	-24.0	1.42 V	84	38.1	11.9
8	15540.00	38.2 AV	54.0	-15.8	1.42 V	84	26.3	11.9

REMARKS:

- Emission Level(dBuV/m) = Raw Value(dBuV) + Correction Factor(dB/m)
- Correction Factor(dB/m) = Antenna Factor(dB/m) + Cable Factor(dB) – Pre-Amplifier Factor(dB)
- The other emission levels were very low against the limit.
- Margin value = Emission Level – Limit value
- " * ": Fundamental frequency.
- " # ": The radiated frequency is out of the restricted band.

CHANNEL	TX Channel 40	DETECTOR FUNCTION	Peak (PK)
FREQUENCY RANGE	1GHz ~ 40GHz		Average (AV)

ANTENNA POLARITY & TEST DISTANCE: HORIZONTAL AT 3 M

NO.	FREQ. (MHz)	EMISSION LEVEL (dBuV/m)	LIMIT (dBuV/m)	MARGIN (dB)	ANTENNA HEIGHT (m)	TABLE ANGLE (Degree)	RAW VALUE (dBuV)	CORRECTION FACTOR (dB/m)
1	5150.00	63.3 PK	74.0	-10.7	1.53 H	289	60.4	2.9
2	5150.00	51.1 AV	54.0	-2.9	1.53 H	289	48.2	2.9
3	*5200.00	112.5 PK			1.53 H	289	109.5	3.0
4	*5200.00	101.3 AV			1.53 H	289	98.3	3.0
5	#10400.00	58.7 PK	74.0	-15.3	1.25 H	161	46.7	12.0
6	#10400.00	47.6 AV	54.0	-6.4	1.25 H	161	35.6	12.0
7	15600.00	47.4 PK	74.0	-26.6	1.00 H	54	35.3	12.1
8	15600.00	36.4 AV	54.0	-17.6	1.00 H	54	24.3	12.1

ANTENNA POLARITY & TEST DISTANCE: VERTICAL AT 3 M

NO.	FREQ. (MHz)	EMISSION LEVEL (dBuV/m)	LIMIT (dBuV/m)	MARGIN (dB)	ANTENNA HEIGHT (m)	TABLE ANGLE (Degree)	RAW VALUE (dBuV)	CORRECTION FACTOR (dB/m)
1	5150.00	65.7 PK	74.0	-8.3	1.00 V	301	62.8	2.9
2	5150.00	53.0 AV	54.0	-1.0	1.00 V	301	50.1	2.9
3	*5200.00	116.5 PK			1.00 V	301	113.5	3.0
4	*5200.00	106.0 AV			1.00 V	301	103.0	3.0
5	#10400.00	67.2 PK	74.0	-6.8	1.15 V	203	55.2	12.0
6	#10400.00	53.1 AV	54.0	-0.9	1.15 V	203	41.1	12.0
7	15600.00	49.3 PK	74.0	-24.7	1.40 V	81	37.2	12.1
8	15600.00	38.0 AV	54.0	-16.0	1.40 V	81	25.9	12.1

REMARKS:

1. Emission Level(dBuV/m) = Raw Value(dBuV) + Correction Factor(dB/m)
2. Correction Factor(dB/m) = Antenna Factor(dB/m) + Cable Factor(dB) – Pre-Amplifier Factor(dB)
3. The other emission levels were very low against the limit.
4. Margin value = Emission Level – Limit value
5. " * ": Fundamental frequency.
6. " # ": The radiated frequency is out of the restricted band.

CHANNEL	TX Channel 48	DETECTOR FUNCTION	Peak (PK)
FREQUENCY RANGE	1GHz ~ 40GHz		Average (AV)

ANTENNA POLARITY & TEST DISTANCE: HORIZONTAL AT 3 M

NO.	FREQ. (MHz)	EMISSION LEVEL (dBuV/m)	LIMIT (dBuV/m)	MARGIN (dB)	ANTENNA HEIGHT (m)	TABLE ANGLE (Degree)	RAW VALUE (dBuV)	CORRECTION FACTOR (dB/m)
1	*5240.00	109.6 PK			1.55 H	291	106.4	3.2
2	*5240.00	99.7 AV			1.55 H	291	96.5	3.2
3	5350.00	46.1 PK	74.0	-27.9	1.55 H	291	42.7	3.4
4	5350.00	34.3 AV	54.0	-19.7	1.55 H	291	30.9	3.4
5	#10480.00	59.5 PK	74.0	-14.5	1.34 H	117	47.3	12.2
6	#10480.00	47.9 AV	54.0	-6.1	1.34 H	117	35.7	12.2
7	15720.00	48.5 PK	74.0	-25.5	1.00 H	46	35.6	12.9
8	15720.00	36.3 AV	54.0	-17.7	1.00 H	46	23.4	12.9

ANTENNA POLARITY & TEST DISTANCE: VERTICAL AT 3 M

NO.	FREQ. (MHz)	EMISSION LEVEL (dBuV/m)	LIMIT (dBuV/m)	MARGIN (dB)	ANTENNA HEIGHT (m)	TABLE ANGLE (Degree)	RAW VALUE (dBuV)	CORRECTION FACTOR (dB/m)
1	*5240.00	113.2 PK			1.12 V	301	110.0	3.2
2	*5240.00	103.3 AV			1.12 V	301	100.1	3.2
3	5350.00	49.2 PK	74.0	-24.8	1.12 V	301	45.8	3.4
4	5350.00	36.7 AV	54.0	-17.3	1.12 V	301	33.3	3.4
5	#10480.00	66.4 PK	74.0	-7.6	1.11 V	218	54.2	12.2
6	#10480.00	52.4 AV	54.0	-1.6	1.11 V	218	40.2	12.2
7	15720.00	51.1 PK	74.0	-22.9	1.45 V	85	38.2	12.9
8	15720.00	39.1 AV	54.0	-14.9	1.45 V	85	26.2	12.9

REMARKS:

1. Emission Level(dBuV/m) = Raw Value(dBuV) + Correction Factor(dB/m)
2. Correction Factor(dB/m) = Antenna Factor(dB/m) + Cable Factor(dB) – Pre-Amplifier Factor(dB)
3. The other emission levels were very low against the limit.
4. Margin value = Emission Level – Limit value
5. " * ": Fundamental frequency.
6. " # ": The radiated frequency is out of the restricted band.

CHANNEL	TX Channel 149	DETECTOR FUNCTION	Peak (PK)
FREQUENCY RANGE	1GHz ~ 40GHz		Average (AV)

ANTENNA POLARITY & TEST DISTANCE: HORIZONTAL AT 3 M

NO.	FREQ. (MHz)	EMISSION LEVEL (dBuV/m)	LIMIT (dBuV/m)	MARGIN (dB)	ANTENNA HEIGHT (m)	TABLE ANGLE (Degree)	RAW VALUE (dBuV)	CORRECTION FACTOR (dB/m)
1	#5590.85	58.0 PK	68.2	-10.2	1.50 H	275	54.4	3.6
2	*5745.00	110.5 PK			1.50 H	275	106.5	4.0
3	*5745.00	102.9 AV			1.50 H	275	98.9	4.0
4	#6007.90	57.1 PK	68.2	-11.1	1.50 H	275	52.5	4.6
5	11490.00	65.8 PK	74.0	-8.2	1.04 H	217	53.0	12.8
6	11490.00	48.9 AV	54.0	-5.1	1.04 H	217	36.1	12.8
7	#17235.00	50.5 PK	74.0	-23.5	1.46 H	324	33.1	17.4
8	#17235.00	40.4 AV	54.0	-13.6	1.46 H	324	23.0	17.4

ANTENNA POLARITY & TEST DISTANCE: VERTICAL AT 3 M

NO.	FREQ. (MHz)	EMISSION LEVEL (dBuV/m)	LIMIT (dBuV/m)	MARGIN (dB)	ANTENNA HEIGHT (m)	TABLE ANGLE (Degree)	RAW VALUE (dBuV)	CORRECTION FACTOR (dB/m)
1	#5622.48	56.1 PK	68.2	-12.1	1.21 V	287	52.3	3.8
2	*5745.00	113.5 PK			1.21 V	287	109.5	4.0
3	*5745.00	103.6 AV			1.21 V	287	99.6	4.0
4	#5984.66	55.7 PK	68.2	-12.5	1.21 V	287	51.2	4.5
5	11490.00	66.7 PK	74.0	-7.3	1.16 V	242	53.9	12.8
6	11490.00	50.7 AV	54.0	-3.3	1.16 V	242	37.9	12.8
7	#17235.00	55.4 PK	74.0	-18.6	1.16 V	234	38.0	17.4
8	#17235.00	44.7 AV	54.0	-9.3	1.16 V	234	27.3	17.4

REMARKS:

1. Emission Level(dBuV/m) = Raw Value(dBuV) + Correction Factor(dB/m)
2. Correction Factor(dB/m) = Antenna Factor(dB/m) + Cable Factor(dB) – Pre-Amplifier Factor(dB)
3. The other emission levels were very low against the limit.
4. Margin value = Emission Level – Limit value
5. " * ": Fundamental frequency.
6. " # ": The radiated frequency is out of the restricted band.

CHANNEL	TX Channel 157	DETECTOR FUNCTION	Peak (PK)
FREQUENCY RANGE	1GHz ~ 40GHz		Average (AV)

ANTENNA POLARITY & TEST DISTANCE: HORIZONTAL AT 3 M

NO.	FREQ. (MHz)	EMISSION LEVEL (dBuV/m)	LIMIT (dBuV/m)	MARGIN (dB)	ANTENNA HEIGHT (m)	TABLE ANGLE (Degree)	RAW VALUE (dBuV)	CORRECTION FACTOR (dB/m)
1	#5586.10	56.5 PK	68.2	-11.7	1.44 H	274	52.9	3.6
2	*5785.00	110.2 PK			1.44 H	274	106.2	4.0
3	*5785.00	102.8 AV			1.44 H	274	98.8	4.0
4	#5956.60	56.9 PK	68.2	-11.3	1.44 H	274	52.5	4.4
5	11570.00	66.1 PK	74.0	-7.9	1.00 H	235	53.5	12.6
6	11570.00	49.3 AV	54.0	-4.7	1.00 H	235	36.7	12.6
7	#17355.00	50.1 PK	74.0	-23.9	1.55 H	336	32.0	18.1
8	#17355.00	39.9 AV	54.0	-14.1	1.55 H	336	21.8	18.1

ANTENNA POLARITY & TEST DISTANCE: VERTICAL AT 3 M

NO.	FREQ. (MHz)	EMISSION LEVEL (dBuV/m)	LIMIT (dBuV/m)	MARGIN (dB)	ANTENNA HEIGHT (m)	TABLE ANGLE (Degree)	RAW VALUE (dBuV)	CORRECTION FACTOR (dB/m)
1	#5612.63	57.8 PK	68.2	-10.4	1.19 V	273	54.1	3.7
2	*5785.00	113.9 PK			1.19 V	273	109.9	4.0
3	*5785.00	103.7 AV			1.19 V	273	99.7	4.0
4	#5965.99	57.2 PK	68.2	-11.0	1.19 V	273	52.7	4.5
5	11570.00	67.6 PK	74.0	-6.4	1.12 V	226	55.0	12.6
6	11570.00	50.5 AV	54.0	-3.5	1.12 V	226	37.9	12.6
7	#17355.00	55.6 PK	74.0	-18.4	1.11 V	222	37.5	18.1
8	#17355.00	44.9 AV	54.0	-9.1	1.11 V	222	26.8	18.1

REMARKS:

1. Emission Level(dBuV/m) = Raw Value(dBuV) + Correction Factor(dB/m)
2. Correction Factor(dB/m) = Antenna Factor(dB/m) + Cable Factor(dB) – Pre-Amplifier Factor(dB)
3. The other emission levels were very low against the limit.
4. Margin value = Emission Level – Limit value
5. " * ": Fundamental frequency.
6. " # ": The radiated frequency is out of the restricted band.

CHANNEL	TX Channel 165	DETECTOR FUNCTION	Peak (PK)
FREQUENCY RANGE	1GHz ~ 40GHz		Average (AV)

ANTENNA POLARITY & TEST DISTANCE: HORIZONTAL AT 3 M

NO.	FREQ. (MHz)	EMISSION LEVEL (dBuV/m)	LIMIT (dBuV/m)	MARGIN (dB)	ANTENNA HEIGHT (m)	TABLE ANGLE (Degree)	RAW VALUE (dBuV)	CORRECTION FACTOR (dB/m)
1	#5599.40	57.4 PK	68.2	-10.8	1.46 H	271	53.8	3.6
2	*5825.00	110.3 PK			1.46 H	271	106.2	4.1
3	*5825.00	102.7 AV			1.46 H	271	98.6	4.1
4	#5972.75	58.6 PK	68.2	-9.6	1.46 H	271	54.1	4.5
5	11650.00	65.7 PK	74.0	-8.3	1.00 H	223	52.9	12.8
6	11650.00	48.8 AV	54.0	-5.2	1.00 H	223	36.0	12.8
7	#17475.00	50.6 PK	74.0	-23.4	1.50 H	320	31.8	18.8
8	#17475.00	40.3 AV	54.0	-13.7	1.50 H	320	21.5	18.8

ANTENNA POLARITY & TEST DISTANCE: VERTICAL AT 3 M

NO.	FREQ. (MHz)	EMISSION LEVEL (dBuV/m)	LIMIT (dBuV/m)	MARGIN (dB)	ANTENNA HEIGHT (m)	TABLE ANGLE (Degree)	RAW VALUE (dBuV)	CORRECTION FACTOR (dB/m)
1	#5622.05	56.0 PK	68.2	-12.2	1.18 V	272	52.2	3.8
2	*5825.00	113.7 PK			1.18 V	272	109.6	4.1
3	*5825.00	103.5 AV			1.18 V	272	99.4	4.1
4	#5982.18	56.3 PK	68.2	-11.9	1.18 V	272	51.8	4.5
5	11650.00	67.0 PK	74.0	-7.0	1.11 V	215	54.2	12.8
6	11650.00	50.8 AV	54.0	-3.2	1.11 V	215	38.0	12.8
7	#17475.00	55.7 PK	74.0	-18.3	1.16 V	224	36.9	18.8
8	#17475.00	44.9 AV	54.0	-9.1	1.16 V	224	26.1	18.8

REMARKS:

1. Emission Level(dBuV/m) = Raw Value(dBuV) + Correction Factor(dB/m)
2. Correction Factor(dB/m) = Antenna Factor(dB/m) + Cable Factor(dB) – Pre-Amplifier Factor(dB)
3. The other emission levels were very low against the limit.
4. Margin value = Emission Level – Limit value
5. " * ": Fundamental frequency.
6. " # ": The radiated frequency is out of the restricted band.

802.11ac (VHT40)

CHANNEL	TX Channel 38	DETECTOR FUNCTION	Peak (PK)
FREQUENCY RANGE	1GHz ~ 40GHz		Average (AV)

ANTENNA POLARITY & TEST DISTANCE: HORIZONTAL AT 3 M

NO.	FREQ. (MHz)	EMISSION LEVEL (dBuV/m)	LIMIT (dBuV/m)	MARGIN (dB)	ANTENNA HEIGHT (m)	TABLE ANGLE (Degree)	RAW VALUE (dBuV)	CORRECTION FACTOR (dB/m)
1	5150.00	58.9 PK	74.0	-15.1	1.37 H	290	56.0	2.9
2	5150.00	47.3 AV	54.0	-6.7	1.37 H	290	44.4	2.9
3	*5190.00	97.7 PK			1.37 H	290	94.7	3.0
4	*5190.00	88.8 AV			1.37 H	290	85.8	3.0
5	5350.00	50.0 PK	74.0	-24.0	1.37 H	290	46.6	3.4
6	5350.00	38.2 AV	54.0	-15.8	1.37 H	290	34.8	3.4
7	#10380.00	50.6 PK	74.0	-23.4	1.30 H	114	38.5	12.1
8	#10380.00	39.5 AV	54.0	-14.5	1.30 H	114	27.4	12.1
9	15570.00	44.5 PK	74.0	-29.5	1.00 H	49	32.4	12.1
10	15570.00	33.3 AV	54.0	-20.7	1.00 H	49	21.2	12.1

ANTENNA POLARITY & TEST DISTANCE: VERTICAL AT 3 M

NO.	FREQ. (MHz)	EMISSION LEVEL (dBuV/m)	LIMIT (dBuV/m)	MARGIN (dB)	ANTENNA HEIGHT (m)	TABLE ANGLE (Degree)	RAW VALUE (dBuV)	CORRECTION FACTOR (dB/m)
1	5150.00	63.5 PK	74.0	-10.5	1.02 V	301	60.6	2.9
2	5150.00	53.4 AV	54.0	-0.6	1.02 V	301	50.5	2.9
3	*5190.00	106.6 PK			1.02 V	301	103.6	3.0
4	*5190.00	96.4 AV			1.02 V	301	93.4	3.0
5	5350.00	51.5 PK	74.0	-22.5	1.02 V	301	48.1	3.4
6	5350.00	38.4 AV	54.0	-15.6	1.02 V	301	35.0	3.4
7	#10380.00	54.0 PK	74.0	-20.0	2.90 V	225	41.9	12.1
8	#10380.00	43.6 AV	54.0	-10.4	2.90 V	225	31.5	12.1
9	15570.00	45.5 PK	74.0	-28.5	1.47 V	77	33.4	12.1
10	15570.00	35.4 AV	54.0	-18.6	1.47 V	77	23.3	12.1

REMARKS:

1. Emission Level(dBuV/m) = Raw Value(dBuV) + Correction Factor(dB/m)
2. Correction Factor(dB/m) = Antenna Factor(dB/m) + Cable Factor(dB) – Pre-Amplifier Factor(dB)
3. The other emission levels were very low against the limit.
4. Margin value = Emission Level – Limit value
5. " * ": Fundamental frequency.
6. " # ": The radiated frequency is out of the restricted band.

CHANNEL	TX Channel 46	DETECTOR FUNCTION	Peak (PK)
FREQUENCY RANGE	1GHz ~ 40GHz		Average (AV)

ANTENNA POLARITY & TEST DISTANCE: HORIZONTAL AT 3 M

NO.	FREQ. (MHz)	EMISSION LEVEL (dBuV/m)	LIMIT (dBuV/m)	MARGIN (dB)	ANTENNA HEIGHT (m)	TABLE ANGLE (Degree)	RAW VALUE (dBuV)	CORRECTION FACTOR (dB/m)
1	5150.00	61.3 PK	74.0	-12.7	1.41 H	277	58.4	2.9
2	5150.00	51.1 AV	54.0	-2.9	1.41 H	277	48.2	2.9
3	*5230.00	108.6 PK			1.41 H	277	105.5	3.1
4	*5230.00	98.2 AV			1.41 H	277	95.1	3.1
5	#10460.00	54.3 PK	74.0	-19.7	1.31 H	98	42.1	12.2
6	#10460.00	44.2 AV	54.0	-9.8	1.31 H	98	32.0	12.2
7	15690.00	46.4 PK	74.0	-27.6	1.01 H	45	33.5	12.9
8	15690.00	36.3 AV	54.0	-17.7	1.01 H	45	23.4	12.9

ANTENNA POLARITY & TEST DISTANCE: VERTICAL AT 3 M

NO.	FREQ. (MHz)	EMISSION LEVEL (dBuV/m)	LIMIT (dBuV/m)	MARGIN (dB)	ANTENNA HEIGHT (m)	TABLE ANGLE (Degree)	RAW VALUE (dBuV)	CORRECTION FACTOR (dB/m)
1	5150.00	64.2 PK	74.0	-9.8	1.06 V	303	61.3	2.9
2	5150.00	53.8 AV	54.0	-0.2	1.06 V	303	50.9	2.9
3	*5230.00	112.4 PK			1.06 V	303	109.3	3.1
4	*5230.00	102.5 AV			1.06 V	303	99.4	3.1
5	#10460.00	56.7 PK	74.0	-17.3	2.92 V	224	44.5	12.2
6	#10460.00	49.1 AV	54.0	-4.9	2.92 V	224	36.9	12.2
7	15690.00	48.7 PK	74.0	-25.3	1.49 V	89	35.8	12.9
8	15690.00	41.9 AV	54.0	-12.1	1.49 V	89	29.0	12.9

REMARKS:

1. Emission Level(dBuV/m) = Raw Value(dBuV) + Correction Factor(dB/m)
2. Correction Factor(dB/m) = Antenna Factor(dB/m) + Cable Factor(dB) – Pre-Amplifier Factor(dB)
3. The other emission levels were very low against the limit.
4. Margin value = Emission Level – Limit value
5. " * ": Fundamental frequency.
6. " # ": The radiated frequency is out of the restricted band.

CHANNEL	TX Channel 151	DETECTOR FUNCTION	Peak (PK)
FREQUENCY RANGE	1GHz ~ 40GHz		Average (AV)

ANTENNA POLARITY & TEST DISTANCE: HORIZONTAL AT 3 M

NO.	FREQ. (MHz)	EMISSION LEVEL (dBuV/m)	LIMIT (dBuV/m)	MARGIN (dB)	ANTENNA HEIGHT (m)	TABLE ANGLE (Degree)	RAW VALUE (dBuV)	CORRECTION FACTOR (dB/m)
1	#5650.23	57.9 PK	68.4	-10.5	1.36 H	276	54.2	3.7
2	*5755.00	108.5 PK			1.36 H	276	104.5	4.0
3	*5755.00	98.2 AV			1.36 H	276	94.2	4.0
4	#5971.80	51.3 PK	68.2	-16.9	1.36 H	276	46.8	4.5
5	11510.00	55.1 PK	74.0	-18.9	1.27 H	97	42.3	12.8
6	11510.00	45.2 AV	54.0	-8.8	1.27 H	97	32.4	12.8
7	#17265.00	47.7 PK	74.0	-26.3	1.01 H	46	30.1	17.6
8	#17265.00	36.9 AV	54.0	-17.1	1.01 H	46	19.3	17.6

ANTENNA POLARITY & TEST DISTANCE: VERTICAL AT 3 M

NO.	FREQ. (MHz)	EMISSION LEVEL (dBuV/m)	LIMIT (dBuV/m)	MARGIN (dB)	ANTENNA HEIGHT (m)	TABLE ANGLE (Degree)	RAW VALUE (dBuV)	CORRECTION FACTOR (dB/m)
1	#5642.62	66.9 PK	68.2	-1.3	1.16 V	299	63.1	3.8
2	*5755.00	112.6 PK			1.16 V	299	108.6	4.0
3	*5755.00	102.9 AV			1.16 V	299	98.9	4.0
4	#5937.60	59.7 PK	68.2	-8.5	1.16 V	299	55.4	4.3
5	11510.00	57.7 PK	74.0	-16.3	2.94 V	229	44.9	12.8
6	11510.00	50.3 AV	54.0	-3.7	2.94 V	229	37.5	12.8
7	#17265.00	49.6 PK	74.0	-24.4	1.54 V	95	32.0	17.6
8	#17265.00	42.6 AV	54.0	-11.4	1.54 V	95	25.0	17.6

REMARKS:

1. Emission Level(dBuV/m) = Raw Value(dBuV) + Correction Factor(dB/m)
2. Correction Factor(dB/m) = Antenna Factor(dB/m) + Cable Factor(dB) – Pre-Amplifier Factor(dB)
3. The other emission levels were very low against the limit.
4. Margin value = Emission Level – Limit value
5. " * ": Fundamental frequency.
6. " # ": The radiated frequency is out of the restricted band.

CHANNEL	TX Channel 159	DETECTOR FUNCTION	Peak (PK)
FREQUENCY RANGE	1GHz ~ 40GHz		Average (AV)

ANTENNA POLARITY & TEST DISTANCE: HORIZONTAL AT 3 M

NO.	FREQ. (MHz)	EMISSION LEVEL (dBuV/m)	LIMIT (dBuV/m)	MARGIN (dB)	ANTENNA HEIGHT (m)	TABLE ANGLE (Degree)	RAW VALUE (dBuV)	CORRECTION FACTOR (dB/m)
1	#5645.00	58.4 PK	68.2	-9.8	1.29 H	278	54.6	3.8
2	*5795.00	109.2 PK			1.29 H	278	105.1	4.1
3	*5795.00	98.7 AV			1.29 H	278	94.6	4.1
4	#5927.15	58.2 PK	68.2	-10.0	1.29 H	278	53.9	4.3
5	11590.00	55.6 PK	74.0	-18.4	1.26 H	98	43.0	12.6
6	11590.00	45.6 AV	54.0	-8.4	1.26 H	98	33.0	12.6
7	#17385.00	47.8 PK	74.0	-26.2	1.01 H	34	29.4	18.4
8	#17385.00	37.1 AV	54.0	-16.9	1.01 H	34	18.7	18.4

ANTENNA POLARITY & TEST DISTANCE: VERTICAL AT 3 M

NO.	FREQ. (MHz)	EMISSION LEVEL (dBuV/m)	LIMIT (dBuV/m)	MARGIN (dB)	ANTENNA HEIGHT (m)	TABLE ANGLE (Degree)	RAW VALUE (dBuV)	CORRECTION FACTOR (dB/m)
1	#5639.77	65.9 PK	68.2	-2.3	1.11 V	302	62.1	3.8
2	*5795.00	113.9 PK			1.11 V	302	109.8	4.1
3	*5795.00	103.3 AV			1.11 V	302	99.2	4.1
4	#5933.80	61.2 PK	68.2	-7.0	1.11 V	302	56.9	4.3
5	11590.00	58.5 PK	74.0	-15.5	2.91 V	245	45.9	12.6
6	11590.00	50.9 AV	54.0	-3.1	2.91 V	245	38.3	12.6
7	#17385.00	50.5 PK	74.0	-23.5	1.50 V	95	32.1	18.4
8	#17385.00	43.2 AV	54.0	-10.8	1.50 V	95	24.8	18.4

REMARKS:

1. Emission Level(dBuV/m) = Raw Value(dBuV) + Correction Factor(dB/m)
2. Correction Factor(dB/m) = Antenna Factor(dB/m) + Cable Factor(dB) – Pre-Amplifier Factor(dB)
3. The other emission levels were very low against the limit.
4. Margin value = Emission Level – Limit value
5. " * ": Fundamental frequency.
6. " # ": The radiated frequency is out of the restricted band.

802.11ac (VHT80)

CHANNEL	TX Channel 42	DETECTOR FUNCTION	Peak (PK)
FREQUENCY RANGE	1GHz ~ 40GHz		Average (AV)

ANTENNA POLARITY & TEST DISTANCE: HORIZONTAL AT 3 M

NO.	FREQ. (MHz)	EMISSION LEVEL (dBuV/m)	LIMIT (dBuV/m)	MARGIN (dB)	ANTENNA HEIGHT (m)	TABLE ANGLE (Degree)	RAW VALUE (dBuV)	CORRECTION FACTOR (dB/m)
1	5150.00	61.4 PK	74.0	-12.6	1.41 H	283	58.5	2.9
2	5150.00	51.3 AV	54.0	-2.7	1.41 H	283	48.4	2.9
3	*5210.00	98.1 PK			1.41 H	283	95.1	3.0
4	*5210.00	88.5 AV			1.41 H	283	85.5	3.0
5	#10420.00	51.4 PK	74.0	-22.6	1.35 H	123	39.4	12.0
6	#10420.00	40.1 AV	54.0	-13.9	1.35 H	123	28.1	12.0
7	15630.00	44.4 PK	74.0	-29.6	1.07 H	46	32.0	12.4
8	15630.00	33.4 AV	54.0	-20.6	1.07 H	46	21.0	12.4

ANTENNA POLARITY & TEST DISTANCE: VERTICAL AT 3 M

NO.	FREQ. (MHz)	EMISSION LEVEL (dBuV/m)	LIMIT (dBuV/m)	MARGIN (dB)	ANTENNA HEIGHT (m)	TABLE ANGLE (Degree)	RAW VALUE (dBuV)	CORRECTION FACTOR (dB/m)
1	5150.00	66.8 PK	74.0	-7.2	1.08 V	300	63.9	2.9
2	5150.00	53.5 AV	54.0	-0.5	1.08 V	300	50.6	2.9
3	*5210.00	102.8 PK			1.08 V	300	99.8	3.0
4	*5210.00	92.7 AV			1.08 V	300	89.7	3.0
5	#10420.00	53.5 PK	74.0	-20.5	2.89 V	217	41.5	12.0
6	#10420.00	43.3 AV	54.0	-10.7	2.89 V	217	31.3	12.0
7	15630.00	45.6 PK	74.0	-28.4	1.46 V	72	33.2	12.4
8	15630.00	35.6 AV	54.0	-18.4	1.46 V	72	23.2	12.4

REMARKS:

- Emission Level(dBuV/m) = Raw Value(dBuV) + Correction Factor(dB/m)
- Correction Factor(dB/m) = Antenna Factor(dB/m) + Cable Factor(dB) – Pre-Amplifier Factor(dB)
- The other emission levels were very low against the limit.
- Margin value = Emission Level – Limit value
- " * ": Fundamental frequency.
- " # ": The radiated frequency is out of the restricted band.

CHANNEL	TX Channel 155	DETECTOR FUNCTION	Peak (PK)
FREQUENCY RANGE	1GHz ~ 40GHz		Average (AV)

ANTENNA POLARITY & TEST DISTANCE: HORIZONTAL AT 3 M

NO.	FREQ. (MHz)	EMISSION LEVEL (dBuV/m)	LIMIT (dBuV/m)	MARGIN (dB)	ANTENNA HEIGHT (m)	TABLE ANGLE (Degree)	RAW VALUE (dBuV)	CORRECTION FACTOR (dB/m)
1	#5646.43	62.3 PK	68.2	-5.9	1.30 H	278	58.5	3.8
2	*5775.00	101.4 PK			1.30 H	278	97.4	4.0
3	*5775.00	90.0 AV			1.30 H	278	86.0	4.0
4	#5953.75	57.9 PK	68.2	-10.3	1.30 H	278	53.6	4.3
5	11550.00	53.4 PK	74.0	-20.6	1.32 H	85	40.7	12.7
6	11550.00	44.3 AV	54.0	-9.7	1.32 H	85	31.6	12.7
7	#17325.00	45.6 PK	74.0	-28.4	1.02 H	63	27.8	17.8
8	#17325.00	35.9 AV	54.0	-18.1	1.02 H	63	18.1	17.8

ANTENNA POLARITY & TEST DISTANCE: VERTICAL AT 3 M

NO.	FREQ. (MHz)	EMISSION LEVEL (dBuV/m)	LIMIT (dBuV/m)	MARGIN (dB)	ANTENNA HEIGHT (m)	TABLE ANGLE (Degree)	RAW VALUE (dBuV)	CORRECTION FACTOR (dB/m)
1	#5649.27	67.0 PK	68.2	-1.2	1.12 V	298	63.2	3.8
2	*5775.00	106.2 PK			1.12 V	298	102.2	4.0
3	*5775.00	95.3 AV			1.12 V	298	91.3	4.0
4	#5925.25	59.2 PK	68.2	-9.0	1.12 V	298	54.9	4.3
5	11550.00	56.2 PK	74.0	-17.8	2.94 V	232	43.5	12.7
6	11550.00	48.7 AV	54.0	-5.3	2.94 V	232	36.0	12.7
7	#17325.00	47.5 PK	74.0	-26.5	1.53 V	91	29.7	17.8
8	#17325.00	40.9 AV	54.0	-13.1	1.53 V	91	23.1	17.8

REMARKS:

1. Emission Level(dBuV/m) = Raw Value(dBuV) + Correction Factor(dB/m)
2. Correction Factor(dB/m) = Antenna Factor(dB/m) + Cable Factor(dB) – Pre-Amplifier Factor(dB)
3. The other emission levels were very low against the limit.
4. Margin value = Emission Level – Limit value
5. " * ": Fundamental frequency.
6. " # ": The radiated frequency is out of the restricted band.

Below 1GHz Data:

802.11ac (VHT20)

CHANNEL	TX Channel 157	DETECTOR FUNCTION	Quasi-Peak (QP)
FREQUENCY RANGE	9kHz ~ 1GHz		

ANTENNA POLARITY & TEST DISTANCE: HORIZONTAL AT 3 M

NO.	FREQ. (MHz)	EMISSION LEVEL (dBuV/m)	LIMIT (dBuV/m)	MARGIN (dB)	ANTENNA HEIGHT (m)	TABLE ANGLE (Degree)	RAW VALUE (dBuV)	CORRECTION FACTOR (dB/m)
1	36.16	24.8 QP	40.0	-15.2	1.00 H	196	39.2	-14.4
2	109.90	22.9 QP	43.5	-20.6	2.00 H	269	39.2	-16.3
3	155.57	22.5 QP	43.5	-21.0	2.00 H	56	35.7	-13.2
4	195.87	20.9 QP	43.5	-22.6	1.50 H	266	37.5	-16.6
5	565.54	28.0 QP	46.0	-18.0	1.50 H	323	34.8	-6.8
6	652.52	31.5 QP	46.0	-14.5	1.00 H	360	36.4	-4.9

ANTENNA POLARITY & TEST DISTANCE: VERTICAL AT 3 M

NO.	FREQ. (MHz)	EMISSION LEVEL (dBuV/m)	LIMIT (dBuV/m)	MARGIN (dB)	ANTENNA HEIGHT (m)	TABLE ANGLE (Degree)	RAW VALUE (dBuV)	CORRECTION FACTOR (dB/m)
1	42.95	36.2 QP	40.0	-3.8	1.00 V	326	49.3	-13.1
2	58.66	31.2 QP	40.0	-8.8	1.00 V	292	44.7	-13.5
3	102.41	25.2 QP	43.5	-18.3	1.00 V	25	42.4	-17.2
4	565.54	25.9 QP	46.0	-20.1	1.50 V	340	32.7	-6.8
5	652.52	26.9 QP	46.0	-19.1	1.50 V	293	31.8	-4.9
6	792.03	27.0 QP	46.0	-19.0	1.50 V	23	29.9	-2.9

REMARKS:

1. Emission Level(dBuV/m) = Raw Value(dBuV) + Correction Factor(dB/m)
2. Correction Factor(dB/m) = Antenna Factor(dB/m) + Cable Factor(dB) – Pre-Amplifier Factor(dB)
3. The other emission levels were very low against the limit.
4. Margin value = Emission Level – Limit value

4.2 Conducted Emission Measurement

4.2.1 Limits of Conducted Emission Measurement

Frequency (MHz)	Conducted Limit (dBuV)	
	Quasi-peak	Average
0.15 - 0.5	66 - 56	56 - 46
0.50 - 5.0	56	46
5.0 - 30.0	60	50

Note: 1. The lower limit shall apply at the transition frequencies.

2. The limit decreases in line with the logarithm of the frequency in the range of 0.15 to 0.50MHz.

4.2.2 Test Instruments

DESCRIPTION & MANUFACTURER	MODEL NO.	SERIAL NO.	CALIBRATED DATE	CALIBRATED UNTIL
Test Receiver R&S	ESCS 30	847124/029	Oct. 24, 2016	Oct. 23, 2017
Line-Impedance Stabilization Network (for EUT) R&S	ESH3-Z5	848773/004	Oct. 26, 2016	Oct. 25, 2017
Line-Impedance Stabilization Network (for Peripheral) R&S	ENV216	100072	June 13, 2016	June 12, 2017
50 ohms Terminator	N/A	EMC-02	Sep. 29, 2016	Sep. 28, 2017
RF Cable	5D-FB	COCCAB-001	Sep. 30, 2016	Sep. 29, 2017
10 dB PAD Mini-Circuits	HAT-10+	CONATT-004	June 20, 2016	June 19, 2017
Software BVADT	BVADT_Cond_ V7.3.7.4	NA	NA	NA

Note:

1. The calibration interval of the above test instruments are 12 months and the calibrations are traceable to NML/ROC and NIST/USA.
2. The test was performed in Shielded Room No. 1.
3. Tested Date: Mar. 03 to 16, 2017

4.2.3 Test Procedure

- The EUT was placed 0.4 meters from the conducting wall of the shielded room with EUT being connected to the power mains through a line impedance stabilization network (LISN). Other support units were connected to the power mains through another LISN. The two LISNs provide 50 ohm/ 50uH of coupling impedance for the measuring instrument.
- Both lines of the power mains connected to the EUT were checked for maximum conducted interference.
- The frequency range from 150kHz to 30MHz was searched. Emission levels under (Limit - 20dB) was not recorded.

NOTE: All modes of operation were investigated and the worst-case emissions are reported.

4.2.4 Deviation from Test Standard

No deviation.

4.2.5 Test Setup

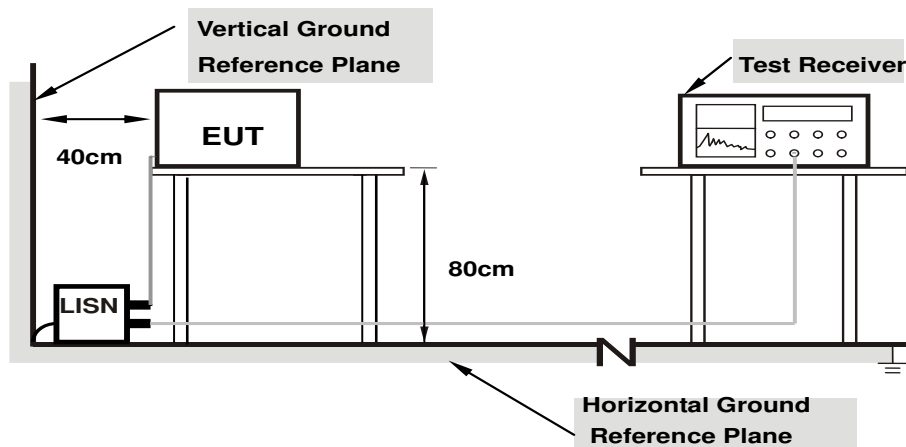

Note: 1.Support units were connected to second LISN.

For the actual test configuration, please refer to the attached file (Test Setup Photo).

4.2.6 EUT Operating Condition

Same as 4.1.6.

4.2.7 Test Results (Mode 1)

Phase	Line (L)	Detector Function	Quasi-Peak (QP) / Average (AV)
-------	----------	-------------------	--------------------------------

No	Freq. [MHz]	Corr. Factor	Reading Value [dB (uV)]		Emission Level [dB (uV)]		Limit [dB (uV)]		Margin (dB)	
		(dB)	Q.P.	AV.	Q.P.	AV.	Q.P.	AV.	Q.P.	AV.
	1	0.15781	10.20	35.70	24.58	45.90	34.78	65.58	55.58	-19.68
2	0.38438	10.24	33.47	32.34	43.71	42.58	58.18	48.18	-14.47	-5.60
3	7.36328	10.55	23.67	21.22	34.22	31.77	60.00	50.00	-25.78	-18.23
4	12.00000	10.96	28.79	28.04	39.75	39.00	60.00	50.00	-20.25	-11.00
5	16.87109	11.45	25.39	20.05	36.84	31.50	60.00	50.00	-23.16	-18.50
6	24.00000	11.76	24.95	24.93	36.71	36.69	60.00	50.00	-23.29	-13.31

REMARKS:

1. Q.P. and AV. are abbreviations of quasi-peak and average individually.
2. The emission levels of other frequencies were very low against the limit.
3. Margin value = Emission level - Limit value
4. Correction factor = Insertion loss + Cable loss
5. Emission Level = Correction Factor + Reading Value.

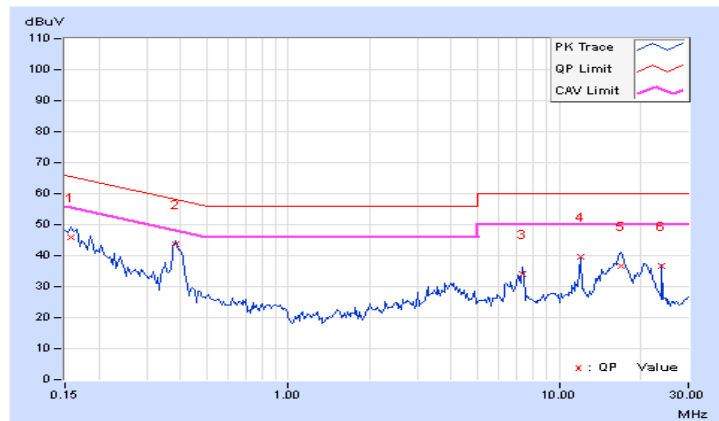

Phase	Neutral (N)	Detector Function	Quasi-Peak (QP) / Average (AV)
-------	-------------	-------------------	--------------------------------

No	Freq. [MHz]	Corr.	Reading Value		Emission Level		Limit		Margin	
		Factor	[dB (uV)]		[dB (uV)]		[dB (uV)]		(dB)	
		(dB)	Q.P.	AV.	Q.P.	AV.	Q.P.	AV.	Q.P.	AV.
1	0.15000	10.19	36.08	25.22	46.27	35.41	66.00	56.00	-19.73	-20.59
2	0.38828	10.24	28.34	24.81	38.58	35.05	58.10	48.10	-19.52	-13.05
3	12.00000	10.81	28.74	28.09	39.55	38.90	60.00	50.00	-20.45	-11.10
4	16.74219	11.19	24.52	19.19	35.71	30.38	60.00	50.00	-24.29	-19.62
5	21.08984	11.38	20.99	15.45	32.37	26.83	60.00	50.00	-27.63	-23.17
6	24.00391	11.39	26.45	25.60	37.84	36.99	60.00	50.00	-22.16	-13.01

REMARKS:

1. Q.P. and AV. are abbreviations of quasi-peak and average individually.
2. The emission levels of other frequencies were very low against the limit.
3. Margin value = Emission level - Limit value
4. Correction factor = Insertion loss + Cable loss
5. Emission Level = Correction Factor + Reading Value.

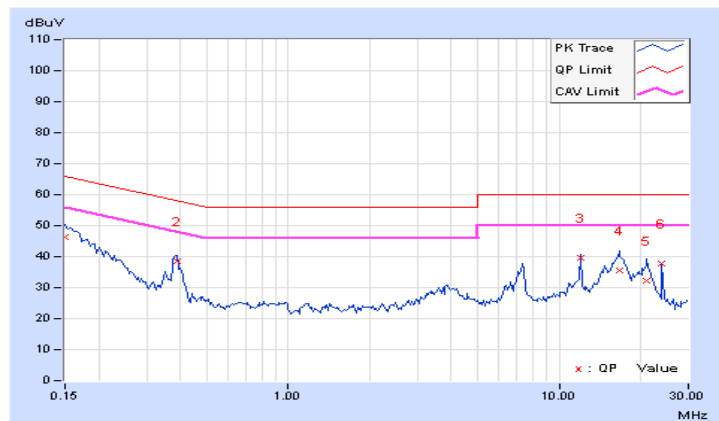

4.2.8 Test Results (Mode 2)

Phase	Line (L)	Detector Function	Quasi-Peak (QP) / Average (AV)
-------	----------	-------------------	--------------------------------

No	Freq. [MHz]	Corr. Factor	Reading Value [dB (uV)]		Emission Level [dB (uV)]		Limit [dB (uV)]		Margin (dB)	
		(dB)	Q.P.	AV.	Q.P.	AV.	Q.P.	AV.	Q.P.	AV.
	1	0.16628	10.19	35.46	26.81	45.65	37.00	65.14	55.14	-19.49
2	0.20344	10.19	30.77	22.21	40.96	32.40	63.47	53.47	-22.51	-21.07
3	0.50300	10.23	30.48	29.12	40.71	39.35	56.00	46.00	-15.29	-6.65
4	4.80859	10.28	24.28	14.76	34.56	25.04	56.00	46.00	-21.44	-20.96
5	15.28516	11.07	32.21	27.09	43.28	38.16	60.00	50.00	-16.72	-11.84
6	24.23438	11.42	31.63	25.53	43.05	36.95	60.00	50.00	-16.95	-13.05

REMARKS:

1. Q.P. and AV. are abbreviations of quasi-peak and average individually.
2. The emission levels of other frequencies were very low against the limit.
3. Margin value = Emission level - Limit value
4. Correction factor = Insertion loss + Cable loss
5. Emission Level = Correction Factor + Reading Value.

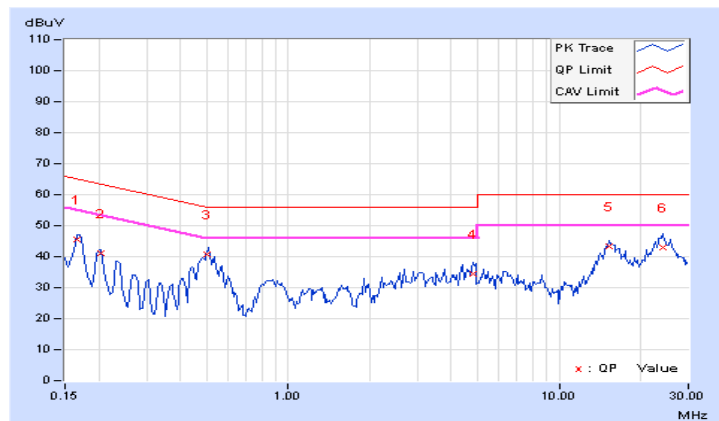

Phase	Neutral (N)	Detector Function	Quasi-Peak (QP) / Average (AV)
-------	-------------	-------------------	--------------------------------

No	Freq. [MHz]	Corr.	Reading Value		Emission Level		Limit		Margin	
		Factor	[dB (uV)]		[dB (uV)]		[dB (uV)]		(dB)	
		(dB)	Q.P.	AV.	Q.P.	AV.	Q.P.	AV.	Q.P.	AV.
1	0.16953	10.17	35.05	25.76	45.22	35.93	64.98	54.98	-19.76	-19.05
2	0.20469	10.16	29.72	19.60	39.88	29.76	63.42	53.42	-23.54	-23.66
3	0.50547	10.21	30.54	28.55	40.75	38.76	56.00	46.00	-15.25	-7.24
4	4.80859	10.20	23.96	13.96	34.16	24.16	56.00	46.00	-21.84	-21.84
5	14.94922	10.88	30.26	24.36	41.14	35.24	60.00	50.00	-18.86	-14.76
6	23.87109	11.08	31.56	25.67	42.64	36.75	60.00	50.00	-17.36	-13.25

REMARKS:

1. Q.P. and AV. are abbreviations of quasi-peak and average individually.
2. The emission levels of other frequencies were very low against the limit.
3. Margin value = Emission level - Limit value
4. Correction factor = Insertion loss + Cable loss
5. Emission Level = Correction Factor + Reading Value.

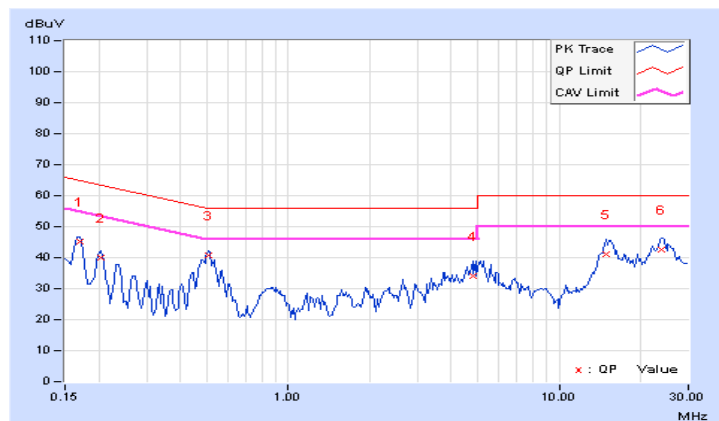

4.3 Transmit Power Measurement

4.3.1 Limits of Transmit Power Measurement

Operation Band	EUT Category		Limit
U-NII-1		Outdoor Access Point	1 Watt (30 dBm) (Max. e.i.r.p \leq 125mW(21 dBm) at any elevation angle above 30 degrees as measured from the horizon)
		Fixed point-to-point Access Point	1 Watt (30 dBm)
	√	Indoor Access Point	1 Watt (30 dBm)
		Mobile and Portable client device	250mW (24 dBm)
U-NII-2A			250mW (24 dBm) or 11 dBm+10 log B*
U-NII-2C			250mW (24 dBm) or 11 dBm+10 log B*
U-NII-3		√	1 Watt (30 dBm)

*B is the 26 dB emission bandwidth in megahertz

Per KDB 662911 Method of conducted output power measurement on IEEE 802.11 devices,

Array Gain = 0 dB (i.e., no array gain) for $N_{ANT} \leq 4$;

Array Gain = 0 dB (i.e., no array gain) for channel widths ≥ 40 MHz for any N_{ANT} ;

Array Gain = $5 \log(N_{ANT}/N_{SS})$ dB or 3 dB, whichever is less for 20-MHz channel widths with $N_{ANT} \geq 5$.

For power measurements on all other devices: Array Gain = $10 \log(N_{ANT}/N_{SS})$ dB.

4.3.2 Test Setup

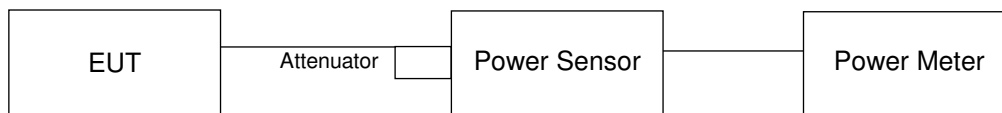

4.3.3 Test Instruments

Refer to section 4.1.2 to get information of above instrument.

4.3.4 Test Procedure

Method PM is used to perform output power measurement, trigger and gating function of wide band power meter is enabled to measure max output power of TX on burst. Duty factor is not added to measured value.

4.3.5 Deviation from Test Standard

No deviation.

4.3.6 EUT Operating Condition

The software provided by client to enable the EUT under transmission condition continuously at lowest, middle and highest channel frequencies individually.

4.3.7 Test Result

802.11a

Chan.	Chan. Freq. (MHz)	Maximum Conducted Power (dBm)		Total Power (mW)	Total Power (dBm)	Limit (dBm)	Pass / Fail
		Chain 0	Chain 1				
36	5180	15.45	15.48	70.393	18.48	30.00	Pass
40	5200	17.58	17.39	112.108	20.50	30.00	Pass
48	5240	16.53	16.53	89.956	19.54	30.00	Pass
149	5745	18.05	19.26	148.159	21.71	30.00	Pass
157	5785	17.88	19.06	141.914	21.52	30.00	Pass
165	5825	17.58	18.85	134.016	21.27	30.00	Pass

802.11ac (VHT20)

Chan.	Chan. Freq. (MHz)	Maximum Conducted Power (dBm)		Total Power (mW)	Total Power (dBm)	Limit (dBm)	Pass / Fail
		Chain 0	Chain 1				
36	5180	14.73	14.93	60.834	17.84	30.00	Pass
40	5200	17.88	17.95	123.749	20.93	30.00	Pass
48	5240	16.31	16.45	86.913	19.39	30.00	Pass
149	5745	17.73	19.52	148.829	21.73	30.00	Pass
157	5785	18.01	19.34	149.142	21.74	30.00	Pass
165	5825	17.62	18.87	134.9	21.30	30.00	Pass

802.11ac (VHT40)

Chan.	Chan. Freq. (MHz)	Maximum Conducted Power (dBm)		Total Power (mW)	Total Power (dBm)	Limit (dBm)	Pass / Fail
		Chain 0	Chain 1				
38	5190	10.06	10.44	21.205	13.26	30.00	Pass
46	5230	16.41	16.79	91.505	19.61	30.00	Pass
151	5755	16.65	16.61	92.052	19.64	30.00	Pass
159	5795	17.42	17.54	111.962	20.49	30.00	Pass

802.11ac (VHT80)

Chan.	Chan. Freq. (MHz)	Maximum Conducted Power (dBm)		Total Power (mW)	Total Power (dBm)	Limit (dBm)	Pass / Fail
		Chain 0	Chain 1				
42	5210	9.85	9.91	19.456	12.89	30.00	Pass
155	5775	13.05	12.90	39.682	15.99	30.00	Pass

4.4 Occupied Bandwidth Measurement

4.4.1 Test Setup

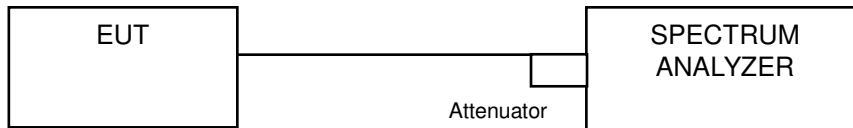

4.4.2 Test Instruments

Refer to section 4.1.2 to get information of above instrument.

4.4.3 Test Procedure

The transmitter output was connected to the spectrum analyzer through an attenuator. The bandwidth of the fundamental frequency was measured by spectrum analyzer with resolution bandwidth in the range of 1% to 5% of the anticipated emission bandwidth, and a video bandwidth at least 3x the resolution bandwidth and set the detector to SAMPLE. The width of a frequency band such that, below the lower and above the upper frequency limits, the mean powers emitted are each equal to a specified percentage 0.5 %of the total mean power of a given emission.

4.4.4 Test Results

802.11a

Channel	Channel Frequency (MHz)	Occupied Bandwidth (MHz)	
		CHAIN 0	CHAIN 1
36	5180	16.80	16.44
40	5200	28.92	24.60
48	5240	17.76	17.52
149	5745	26.40	36.36
157	5785	25.56	37.08
165	5825	29.16	27.12

802.11ac (VHT20)

Channel	Channel Frequency (MHz)	Occupied Bandwidth (MHz)	
		CHAIN 0	CHAIN 1
36	5180	17.64	17.64
40	5200	30.72	31.20
48	5240	17.88	18.24
149	5745	27.24	33.48
157	5785	26.52	42.36
165	5825	29.76	27.48

802.11ac (VHT40)

Channel	Channel Frequency (MHz)	Occupied Bandwidth (MHz)	
		CHAIN 0	CHAIN 1
38	5190	36.24	36.24
46	5230	37.44	36.72
151	5755	37.68	37.44
159	5795	58.80	66.24

802.11ac (VHT80)

Channel	Channel Frequency (MHz)	Occupied Bandwidth (MHz)	
		CHAIN 0	CHAIN 1
42	5210	75.36	74.88
155	5775	75.84	75.36

Spectrum Plot of Worst Value

802.11a_Chain1 / CH157

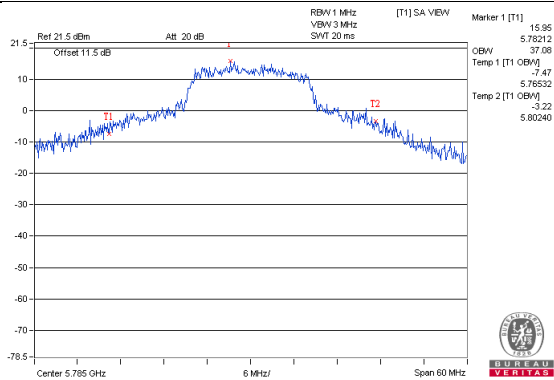

802.11a (VHT20)_Chain1 / CH157

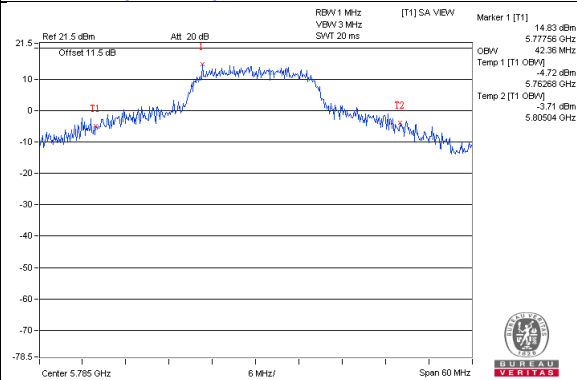

802.11ac (VHT40)_Chain1 / CH159

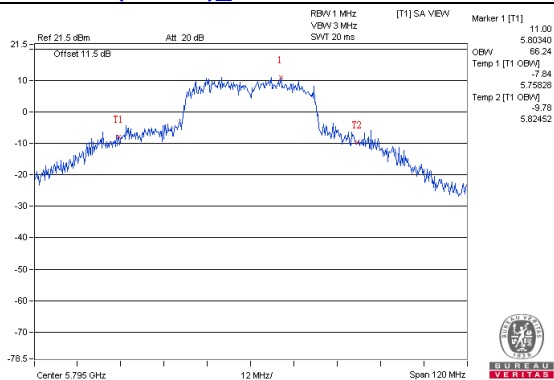

802.11ac (VHT80)_Chain0 / CH155

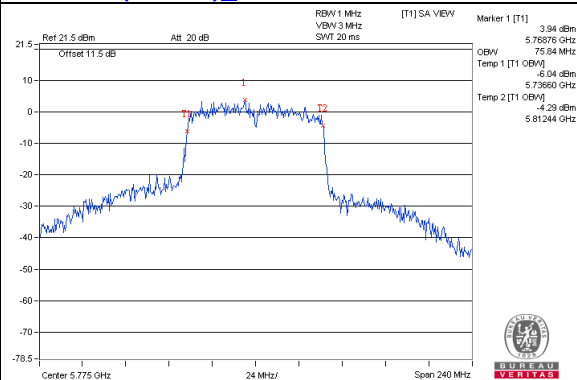

Spectrum Plot for near by DFS band (DFS is required, if 99% OCP straddle into U-NII-2A band)

802.11a_Chain0 / CH48

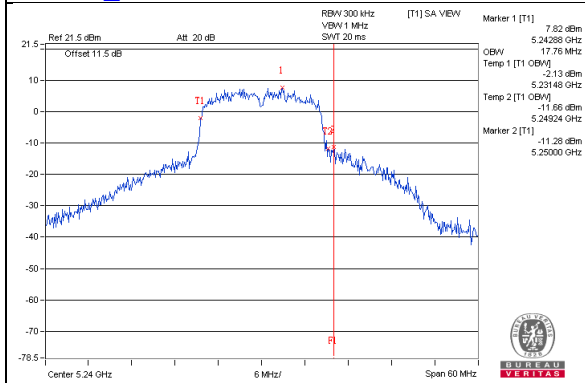

802.11a_Chain1 / CH48

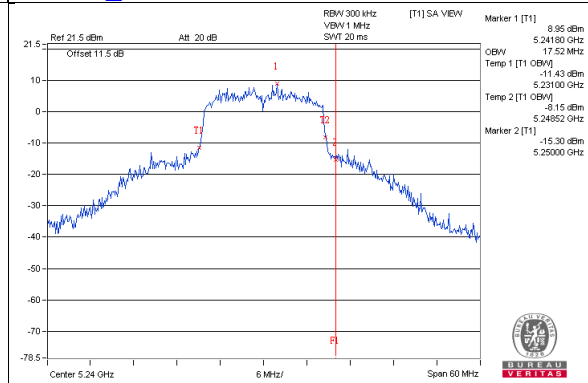

802.11ac(VHT20)_Chain0 / CH48

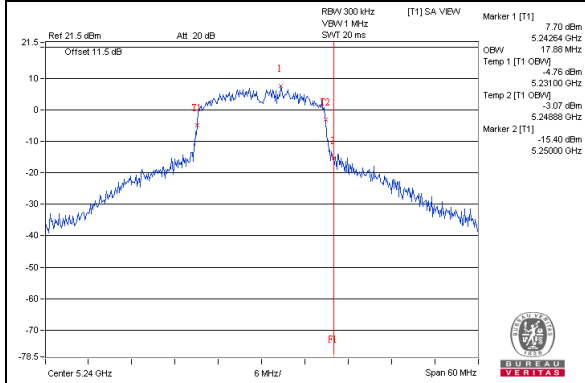

802.11ac(VHT20)_Chain1 / CH48

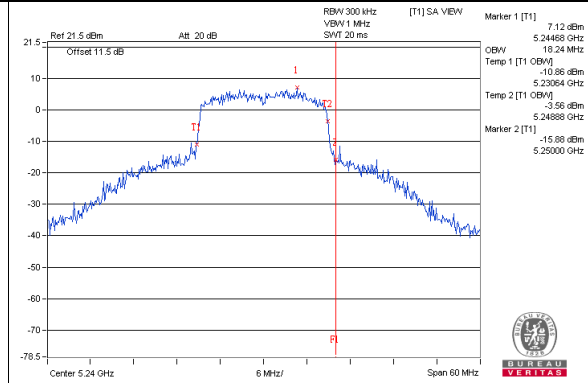

802.11ac(VHT40)_Chain0 / CH46

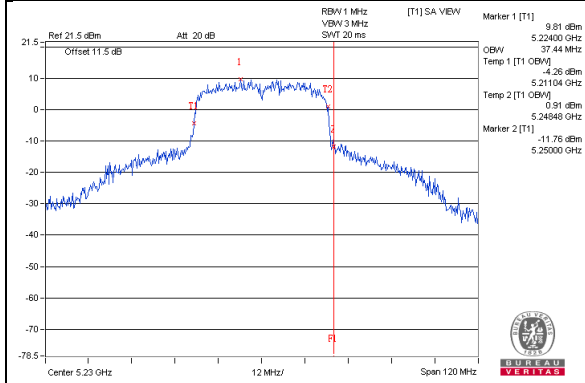

802.11ac(VHT40)_Chain1 / CH46

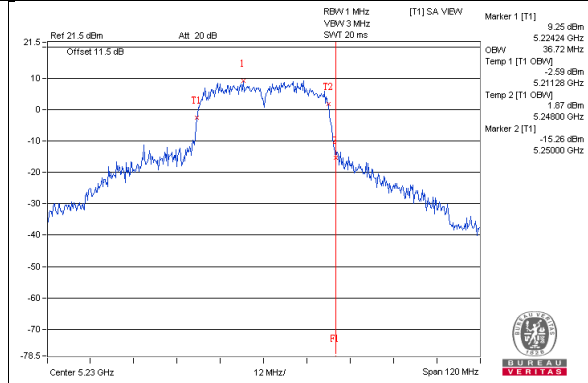

802.11ac(VHT80)_Chain0 / CH42

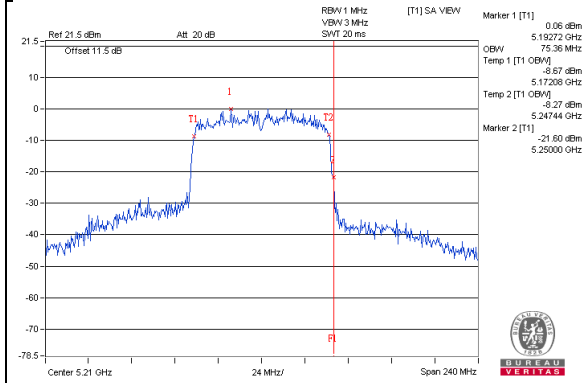

802.11ac(VHT80)_Chain1 / CH42

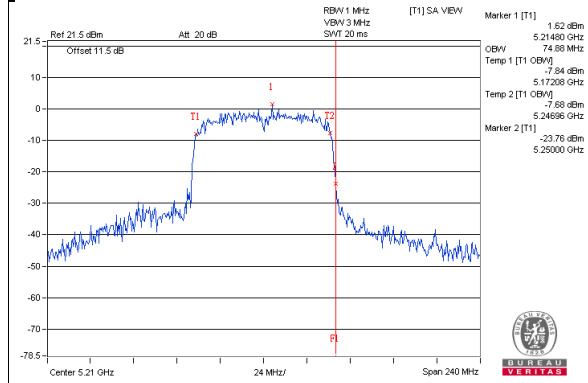

Spectrum Plot for near by DFS band (DFS is required, if 99% OCP straddle into U-NII-2C band)

802.11a_Chain0 / CH149

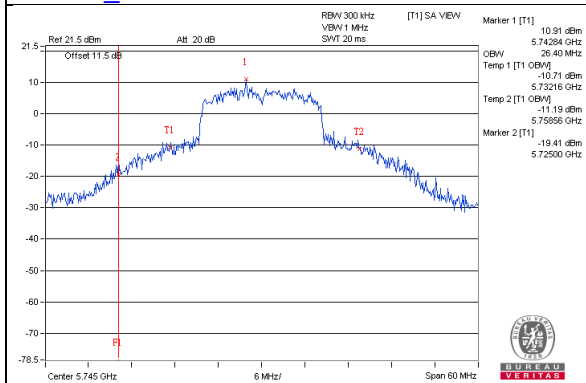

802.11a_Chain1 / CH149

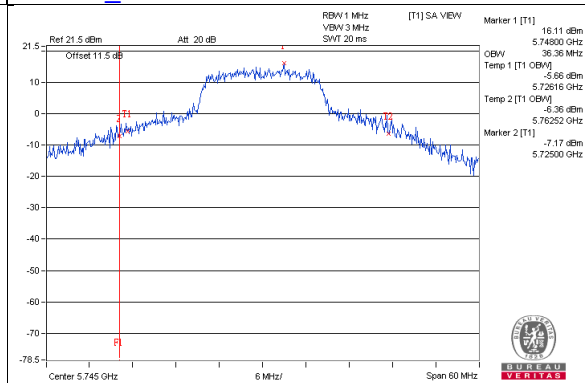

802.11ac(VHT20)_Chain0 / CH149

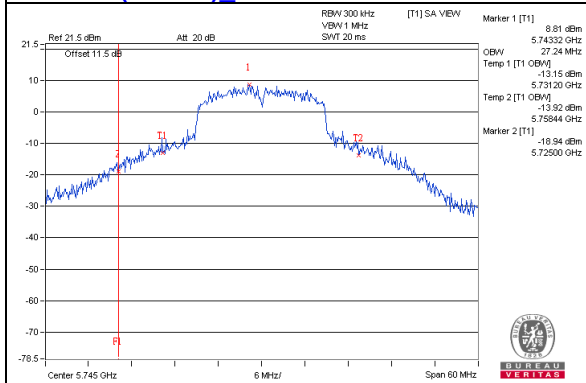

802.11ac(VHT20)_Chain1 / CH149

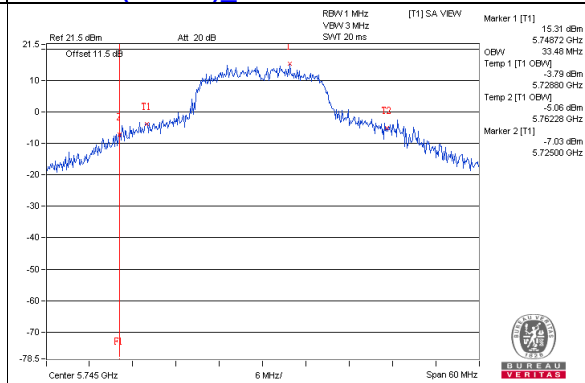

802.11ac(VHT40)_Chain0 / CH151

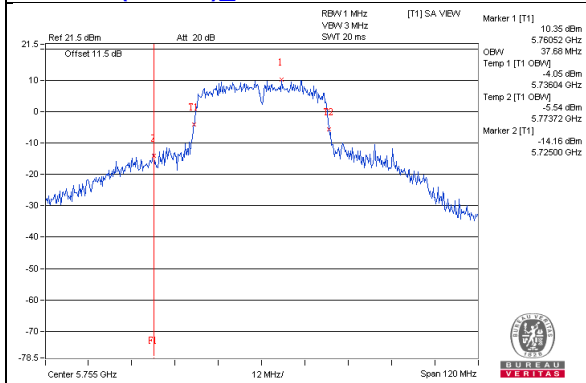

802.11ac(VHT40)_Chain1 / CH151

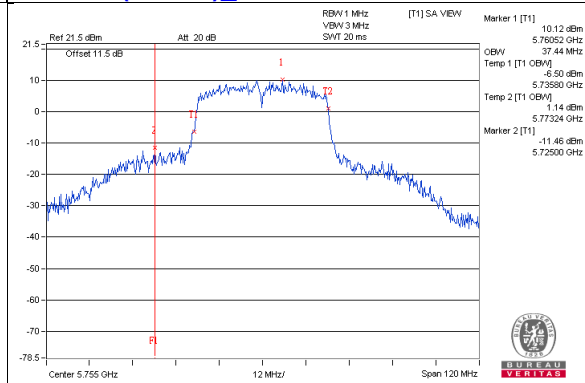

802.11ac(VHT80)_Chain0 / CH155

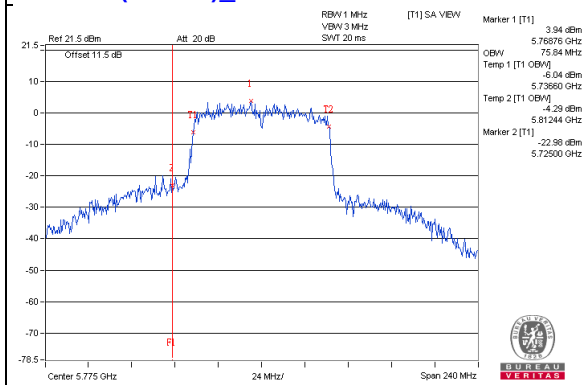

802.11ac(VHT80)_Chain1 / CH155

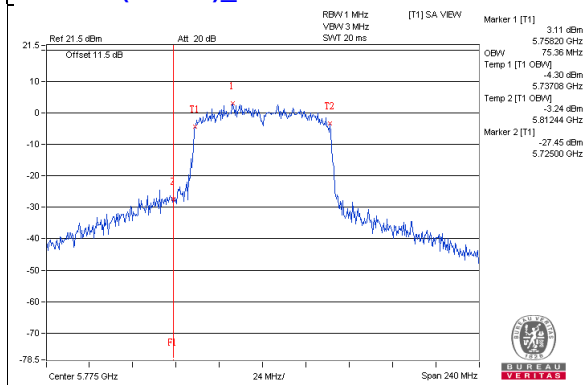

4.5 Peak Power Spectral Density Measurement

4.5.1 Limits of Peak Power Spectral Density Measurement

Operation Band	EUT Category		Limit
U-NII-1		Outdoor Access Point	17dBm/ MHz
		Fixed point-to-point Access Point	
	√	Indoor Access Point	
		Mobile and Portable client device	11dBm/ MHz
U-NII-2A			11dBm/ MHz
U-NII-2C			11dBm/ MHz
U-NII-3	√		30dBm/ 500kHz

4.5.2 Test Setup



4.5.3 Test Instruments

Refer to section 4.1.2 to get information of above instrument.

4.5.4 Test Procedure

802.11a, 802.11ac (VHT20), 802.11ac (VHT40)

For U-NII-1 band:

Using method SA-1

1. Set span to encompass the entire emission bandwidth (EBW) of the signal.
2. Set RBW = 1 MHz, Set VBW \geq 3 MHz, Detector = RMS
3. Sweep time = auto, trigger set to "free run".
4. Trace average at least 100 traces in power averaging mode.
5. Record the max value

For U-NII-3:

1. Set span to encompass the entire emission bandwidth (EBW) of the signal.
2. Set RBW = 300 kHz, Set VBW \geq 1 MHz, Detector = RMS
3. Use the peak marker function to determine the maximum power level in any 300 kHz band segment within the fundamental EBW.
4. Scale the observed power level to an equivalent value in 500 kHz by adjusting (reducing) the measured power by a bandwidth correction factor (BWCF) where $BWCF = 10\log(500 \text{ kHz}/300\text{kHz})$
5. Sweep time = auto, trigger set to "free run".
6. Trace average at least 100 traces in power averaging mode.
7. Record the max value

802.11ac (VHT80)

For U-NII-1 band:

Using method SA-2

1. Set span to encompass the entire emission bandwidth (EBW) of the signal.
2. Set RBW = 1 MHz, Set VBW \geq 3 MHz, Detector = RMS
3. Sweep time = auto, trigger set to "free run".
4. Trace average at least 100 traces in power averaging mode.
5. Record the max value and add $10 \log (1/\text{duty cycle})$

For U-NII-3:

1. Set span to encompass the entire emission bandwidth (EBW) of the signal.
2. Set RBW = 300 kHz, Set VBW \geq 1 MHz, Detector = RMS
3. Use the peak marker function to determine the maximum power level in any 300 kHz band segment within the fundamental EBW.
4. Scale the observed power level to an equivalent value in 500 kHz by adjusting (reducing) the measured power by a bandwidth correction factor (BWCF) where $BWCF = 10\log(500 \text{ kHz}/300\text{kHz})$
5. Sweep time = auto, trigger set to "free run".
6. Trace average at least 100 traces in power averaging mode.
7. Record the max value and add $10 \log (1/\text{duty cycle})$

4.5.5 Deviation from Test Standard

No deviation.

4.5.6 EUT Operating Condition

Same as Item 4.3.6.

4.5.7 Test Results

For U-NII-1:

802.11a

Chan.	Chan. Freq. (MHz)	PSD (dBm/MHz)		Total Power Density (dBm/MHz)	MAX. Limit (dBm/MHz)	Pass / Fail
		Chain 0	Chain 1			
36	5180	2.20	2.17	5.20	17.00	Pass
40	5200	4.47	4.07	7.28	17.00	Pass
48	5240	3.41	3.41	6.42	17.00	Pass

- Note:** 1. Method a) of power density measurement of KDB 662911 is using for calculating total power density. Total power density is summing entire spectra across corresponding frequency bins on the various outputs by computer.
2. Directional gain = $10 \log[(10^{G1/20} + 10^{G2/20})^2 / 2] = 5.68\text{dBi} < 6\text{dBi}$, so the power density limit shall not be reduced.

802.11ac (VHT20)

Chan.	Chan. Freq. (MHz)	PSD (dBm/MHz)		Total Power Density (dBm/MHz)	MAX. Limit (dBm/MHz)	Pass / Fail
		Chain 0	Chain 1			
36	5180	1.80	1.30	4.57	17.00	Pass
40	5200	4.19	4.37	7.29	17.00	Pass
48	5240	2.85	2.91	5.89	17.00	Pass

- Note:** 1. Method a) of power density measurement of KDB 662911 is using for calculating total power density. Total power density is summing entire spectra across corresponding frequency bins on the various outputs by computer.
2. Directional gain = $10 \log[(10^{G1/20} + 10^{G2/20})^2 / 2] = 5.68\text{dBi} < 6\text{dBi}$, so the power density limit shall not be reduced.

802.11ac (VHT40)

Chan.	Chan. Freq. (MHz)	PSD (dBm/MHz)		Total Power Density (dBm/MHz)	MAX. Limit (dBm/MHz)	Pass / Fail
		Chain 0	Chain 1			
38	5190	-5.63	-6.24	-2.91	17.00	Pass
46	5230	-0.13	-0.59	2.66	17.00	Pass

- Note:** 1. Method a) of power density measurement of KDB 662911 is using for calculating total power density. Total power density is summing entire spectra across corresponding frequency bins on the various outputs by computer.
2. Directional gain = $10 \log[(10^{G1/20} + 10^{G2/20})^2 / 2] = 5.68\text{dBi} < 6\text{dBi}$, so the power density limit shall not be reduced.

802.11ac (VHT80)

Chan.	Chan. Freq. (MHz)	PSD W/O Duty Factor (dBm/MHz)		Duty Factor (dB)	Total PSD With Duty Factor (dBm/MHz)	MAX. Limit (dBm/MHz)	Pass / Fail
		Chain 0	Chain 1				
42	5210	-10.61	-10.41	0.09	-7.41	17.00	Pass

- Note:**
- Method a) of power density measurement of KDB 662911 is using for calculating total power density. Total power density is summing entire spectra across corresponding frequency bins on the various outputs by computer.
 - Directional gain = $10 \log[(10^{G1/20} + 10^{G2/20})^2 / 2] = 5.68\text{dBi} < 6\text{dBi}$, so the power density limit shall not be reduced.
 - Refer to section 3.3 for duty cycle spectrum plot.

Spectrum Plot of Worst Value

802.11a_Chain 0 / CH40

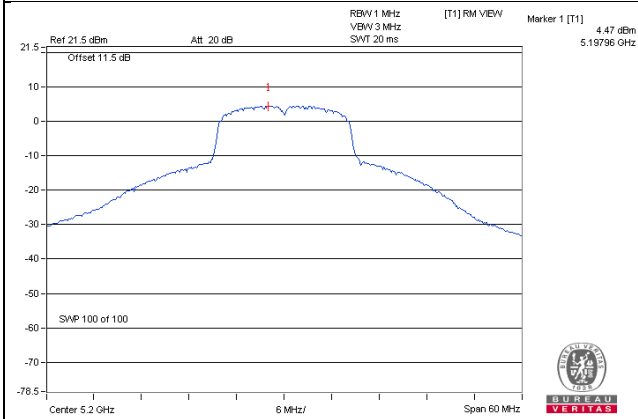

802.11ac (VHT20)_Chain 1 / CH40

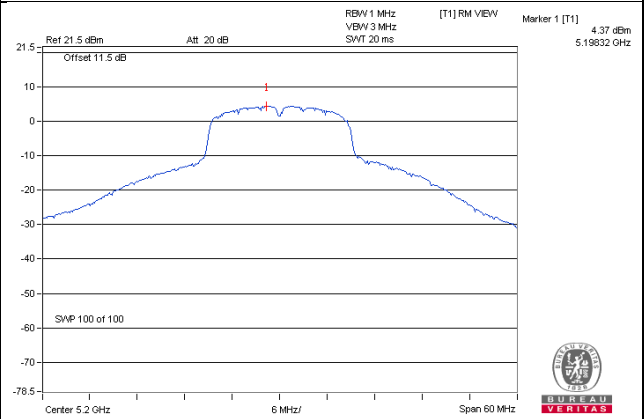

802.11ac (VHT40)_Chain 0 / CH46

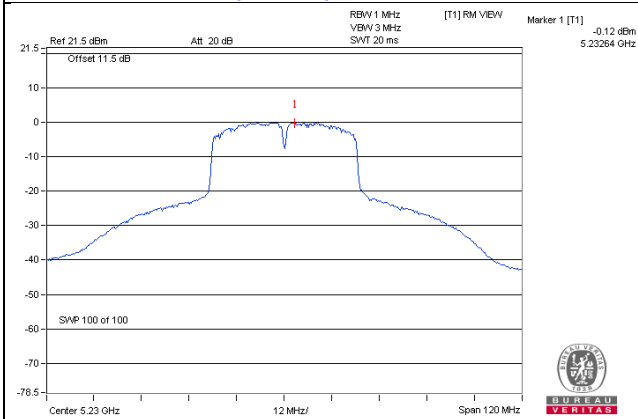

802.11ac (VHT80)_Chain 1 / CH42

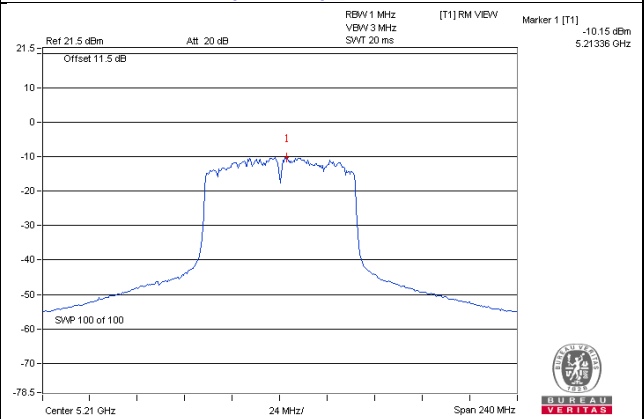

For U-NII-3:
802.11a

TX chain	Channel	Freq. (MHz)	PSD (dBm/300kHz)	PSD (dBm/500kHz)	10 log (N=2) dB	Total PSD (dBm/500kHz)	Limit (dBm/500kHz)	Pass /Fail
0	149	5745	-3.82	-1.60	3.01	1.41	30.00	Pass
	157	5785	-3.92	-1.70	3.01	1.31	30.00	Pass
	165	5825	-4.03	-1.81	3.01	1.20	30.00	Pass
1	149	5745	-2.77	-0.55	3.01	2.46	30.00	Pass
	157	5785	-3.10	-0.88	3.01	2.13	30.00	Pass
	165	5825	-3.23	-1.01	3.01	2.00	30.00	Pass

Note: 1. Directional gain = $10 \log[(10^{G1/20} + 10^{G2/20})^2 / 2] = 5.87\text{dBi} < 6\text{dBi}$, so the power density limit shall not be reduced.

802.11ac (VHT20)

TX chain	Channel	Freq. (MHz)	PSD (dBm/300kHz)	PSD (dBm/500kHz)	10 log (N=2) dB	Total PSD (dBm/500kHz)	Limit (dBm/500kHz)	Pass /Fail
0	149	5745	-3.98	-1.76	3.01	1.25	30.00	Pass
	157	5785	-4.00	-1.78	3.01	1.23	30.00	Pass
	165	5825	-4.07	-1.85	3.01	1.16	30.00	Pass
1	149	5745	-3.30	-1.08	3.01	1.93	30.00	Pass
	157	5785	-3.12	-0.90	3.01	2.11	30.00	Pass
	165	5825	-4.13	-1.91	3.01	1.10	30.00	Pass

Note: 1. Directional gain = $10 \log[(10^{G1/20} + 10^{G2/20})^2 / 2] = 5.87\text{dBi} < 6\text{dBi}$, so the power density limit shall not be reduced.

802.11ac (VHT40)

TX chain	Channel	Freq. (MHz)	PSD (dBm/300kHz)	PSD (dBm/500kHz)	10 log (N=2) dB	Total PSD (dBm/500kHz)	Limit (dBm/500kHz)	Pass /Fail
0	151	5755	-8.40	-6.18	3.01	-3.17	30.00	Pass
	159	5795	-7.67	-5.45	3.01	-2.44	30.00	Pass
1	151	5755	-8.51	-6.29	3.01	-3.28	30.00	Pass
	159	5795	-7.37	-5.15	3.01	-2.14	30.00	Pass

Note: 1. Directional gain = $10 \log[(10^{G1/20} + 10^{G2/20})^2 / 2] = 5.87\text{dBi} < 6\text{dBi}$, so the power density limit shall not be reduced.

802.11ac (VHT80)

TX chain	Chan.	Chan. Freq. (MHz)	PSD W/O Duty Factor		10 log (N=2) dB	Duty Factor (dB)	Total PSD With Duty Factor (dBm/500kHz)	Limit (dBm/500kHz)	Pass /Fail
			(dBm/300kHz)	(dBm/500kHz)					
0	155	5775	-14.96	-12.74	3.01	0.09	-9.64	30.00	Pass
1	155	5775	-15.47	-13.25	3.01	0.09	-10.15	30.00	Pass

Note: 1. Directional gain = $10 \log[(10^{G1/20} + 10^{G2/20})^2 / 2]$ = 5.87dBi < 6dBi , so the power density limit shall not be reduced.

Spectrum Plot of Worst Value

802.11a – Chain 1: CH 149

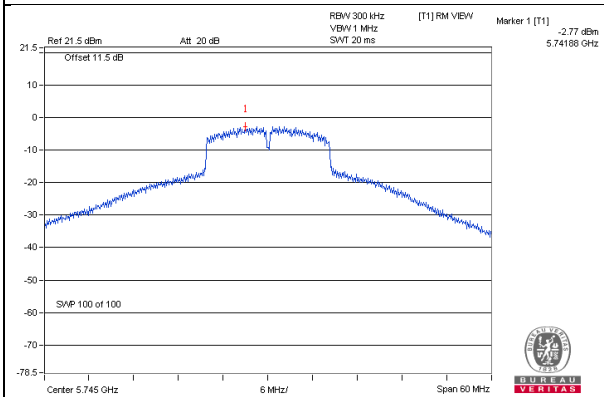

802.11ac (VHT20) – Chain 1: CH 157

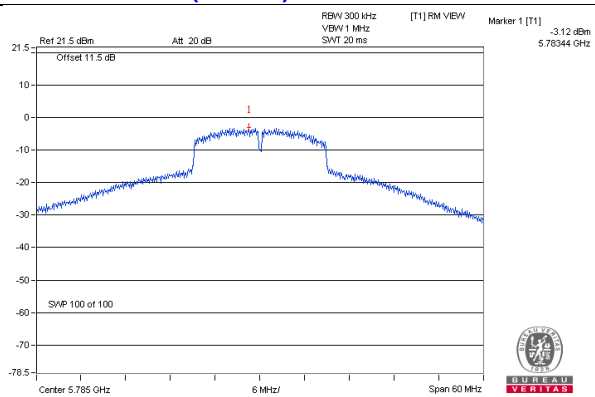

802.11ac (VHT40) – Chain 1: CH 159

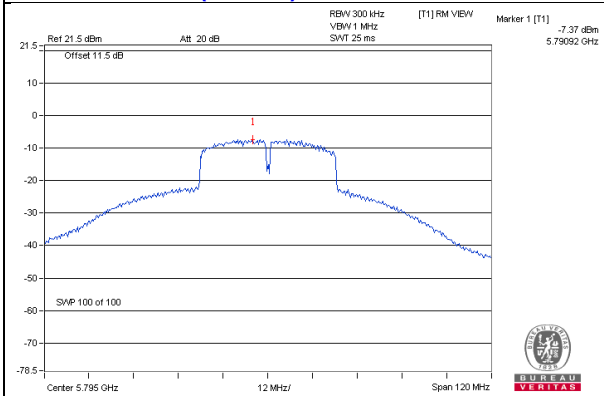

802.11ac (VHT80) – Chain 0: CH 155

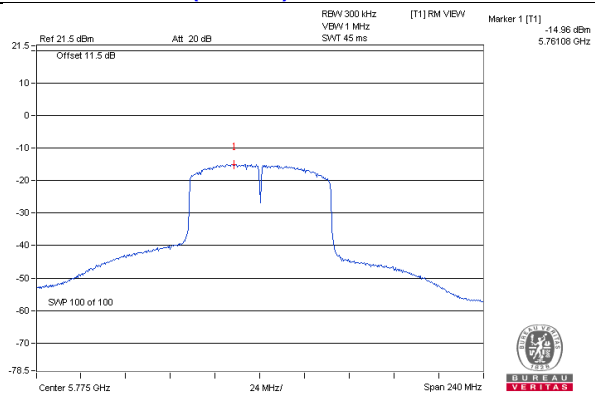

4.6 Frequency Stability Measurement

4.6.1 Limits of Frequency Stability Measurement

The frequency of the carrier signal shall be maintained within band of operation

4.6.2 Test Setup

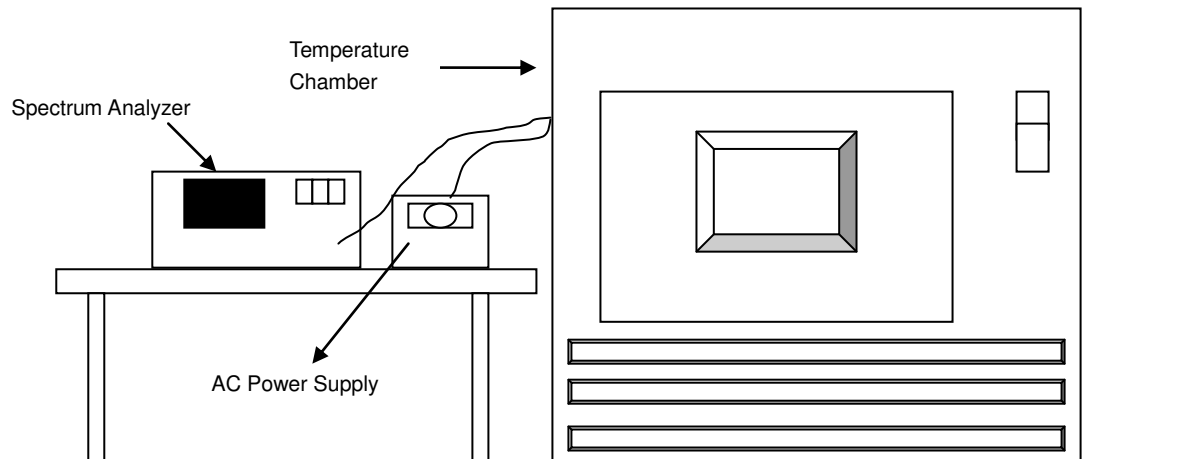

4.6.3 Test Instruments

Refer to section 4.1.2 to get information of above instrument.

4.6.4 Test Procedure

- The EUT was placed inside the environmental test chamber and powered by nominal AC voltage.
- Turn the EUT on and couple its output to a spectrum analyzer.
- Turn the EUT off and set the chamber to the highest temperature specified.
- Allow sufficient time (approximately 30 min) for the temperature of the chamber to stabilize, turn the EUT on and measure the operating frequency after 2, 5, and 10 Minutes.
- Repeat step 2 and 3 with the temperature chamber set to the lowest temperature.
- The test chamber was allowed to stabilize at +20 degree C for a minimum of 30 Minutes. The supply voltage was then adjusted on the EUT from 85% to 115% and the frequency record.

4.6.5 Deviation from Test Standard

No deviation.

4.6.6 EUT Operating Condition

Set the EUT transmit at un-modulation mode to test frequency stability.

4.6.7 Test Results

Frequency Stability Versus Temp.									
Operating Frequency: 5180 MHz									
TEMP. (°C)	Power Supply (Vac)	0 Minute		2 Minute		5 Minute		10 Minute	
		Measured Frequency (MHz)	Pass/Fail	Measured Frequency (MHz)	Pass/Fail	Measured Frequency (MHz)	Pass/Fail	Measured Frequency (MHz)	Pass/Fail
50	120	5179.9839	PASS	5179.9827	PASS	5179.9818	PASS	5179.9812	PASS
40	120	5179.9806	PASS	5179.98	PASS	5179.9794	PASS	5179.9778	PASS
30	120	5179.9918	PASS	5179.9945	PASS	5179.9943	PASS	5179.9928	PASS
20	120	5179.9801	PASS	5179.9776	PASS	5179.9782	PASS	5179.9782	PASS
10	120	5180.0258	PASS	5180.0228	PASS	5180.0248	PASS	5180.0226	PASS
0	120	5179.9871	PASS	5179.9855	PASS	5179.9898	PASS	5179.9879	PASS
-10	120	5180.003	PASS	5180.0019	PASS	5180.0049	PASS	5180.0031	PASS
-20	120	5180.0257	PASS	5180.026	PASS	5180.0269	PASS	5180.026	PASS
-30	120	5180.0167	PASS	5180.0195	PASS	5180.0194	PASS	5180.0189	PASS

Frequency Stability Versus Voltage									
Operating Frequency: 5180 MHz									
TEMP. (°C)	Power Supply (Vac)	0 Minute		2 Minute		5 Minute		10 Minute	
		Measured Frequency (MHz)	Pass/Fail	Measured Frequency (MHz)	Pass/Fail	Measured Frequency (MHz)	Pass/Fail	Measured Frequency (MHz)	Pass/Fail
20	138	5179.9798	PASS	5179.9786	PASS	5179.9785	PASS	5179.9787	PASS
	120	5179.9801	PASS	5179.9776	PASS	5179.9782	PASS	5179.9782	PASS
	102	5179.9791	PASS	5179.9784	PASS	5179.9775	PASS	5179.9781	PASS

4.7 6dB Bandwidth Measurement

4.7.1 Limits of 6dB Bandwidth Measurement

The minimum of 6dB Bandwidth Measurement is 0.5MHz.

4.7.2 Test Setup

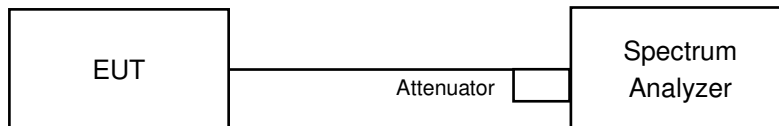

4.7.3 Test Instruments

Refer to section 4.1.2 to get information of above instrument.

4.7.4 Test Procedure

MEASUREMENT PROCEDURE REF

- Set resolution bandwidth (RBW) = 100kHz
- Set the video bandwidth (VBW) $\geq 3 \times$ RBW, Detector = Peak.
- Trace mode = max hold.
- Sweep = auto couple.
- Measure the maximum width of the emission that is constrained by the frequencies associated with the two amplitude points (upper and lower) that are attenuated by 6 dB relative to the maximum level measured in the fundamental emission

4.7.5 Deviation from Test Standard

No deviation.

4.7.6 EUT Operating Condition

The software provided by client to enable the EUT under transmission condition continuously at lowest, middle and highest channel frequencies individually.

4.7.7 Test Results

802.11a

Channel	Frequency (MHz)	6dB Bandwidth (MHz)		Minimum Limit (MHz)	Pass / Fail
		Chain 0	Chain 1		
149	5745	15.94	15.96	0.5	PASS
157	5785	16.34	16.05	0.5	PASS
165	5825	15.59	15.34	0.5	PASS

802.11ac (VHT20)

Channel	Frequency (MHz)	6dB Bandwidth (MHz)		Minimum Limit (MHz)	Pass / Fail
		Chain 0	Chain 1		
149	5745	16.31	17.52	0.5	PASS
157	5785	16.02	15.42	0.5	PASS
165	5825	17.52	15.35	0.5	PASS

802.11ac (VHT40)

Channel	Frequency (MHz)	6dB Bandwidth (MHz)		Minimum Limit (MHz)	Pass / Fail
		Chain 0	Chain 1		
151	5755	34.17	33.47	0.5	PASS
159	5795	33.91	32.12	0.5	PASS

802.11ac (VHT80)

Channel	Frequency (MHz)	6dB Bandwidth (MHz)		Minimum Limit (MHz)	Pass / Fail
		Chain 0	Chain 1		
155	5775	72.74	71.53	0.5	PASS

Spectrum Plot of Worst Value

802.11a_Chain 1 / CH165

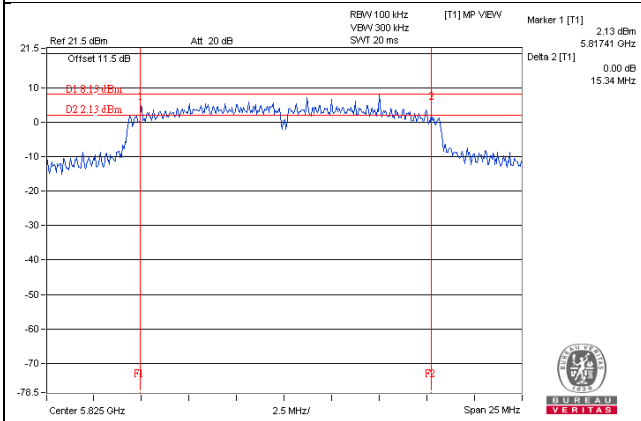

802.11ac (VHT20)_Chain 1 / CH165

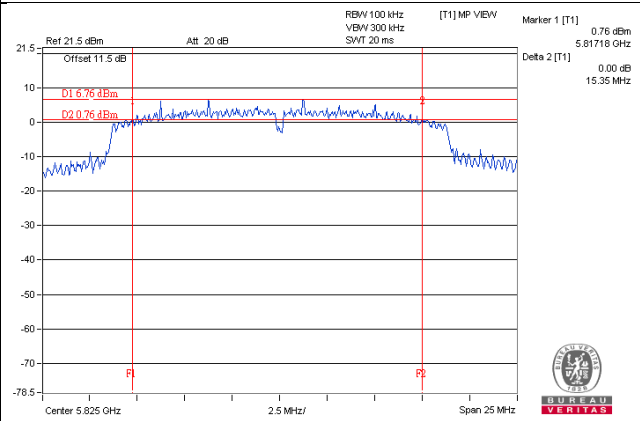

802.11ac (VHT40)_Chain 1 / CH159

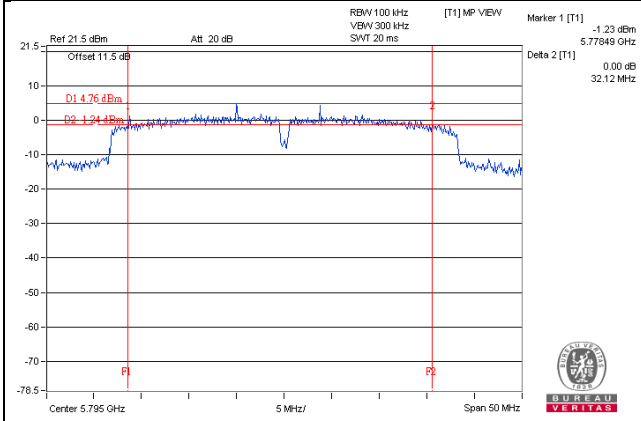

802.11ac (VHT80)_Chain 1 / CH155

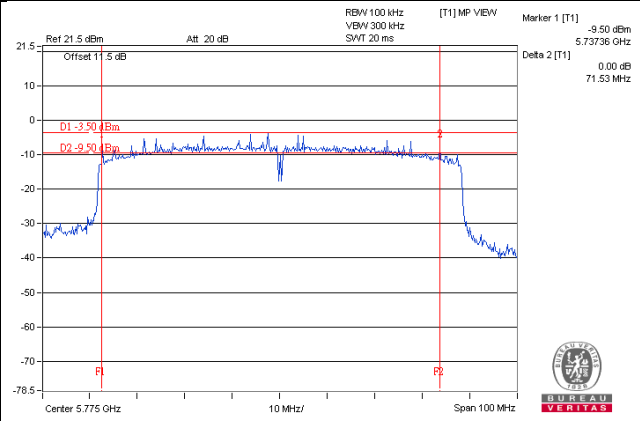

5 Pictures of Test Arrangements

Please refer to the attached file (Test Setup Photo).

Annex A- Radiated Out of Band Emission (OOBE) Measurement (For U-NII-3 band)

802.11a

CH 149 5745 MHz

Horizontal

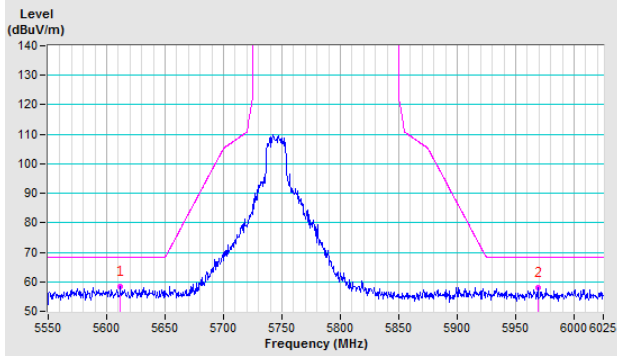

Vertical

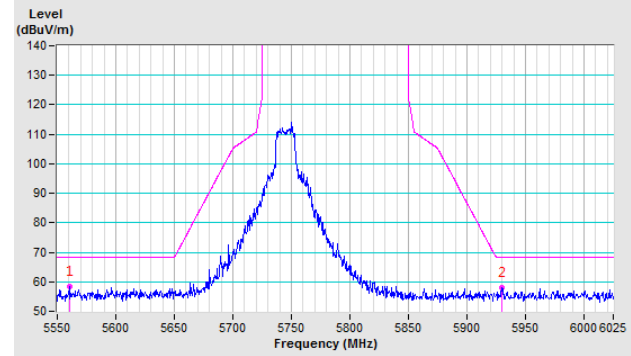

CH 157 5785 MHz

Horizontal

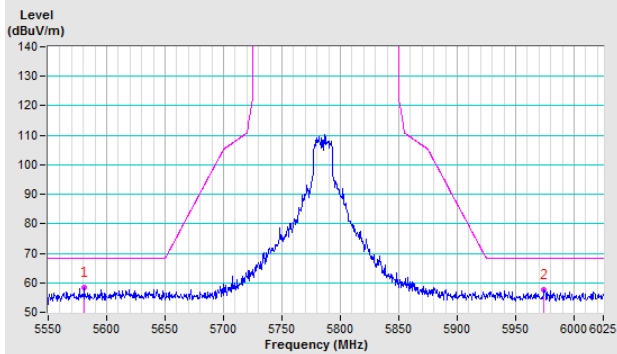

Vertical

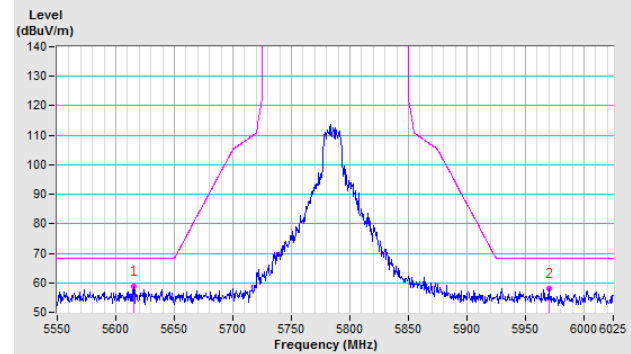

CH 165 5825 MHz

Horizontal

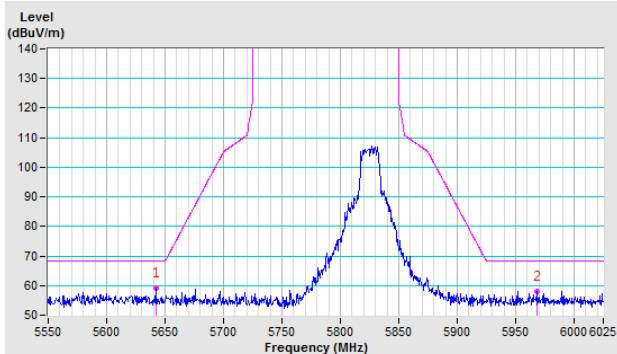

Vertical

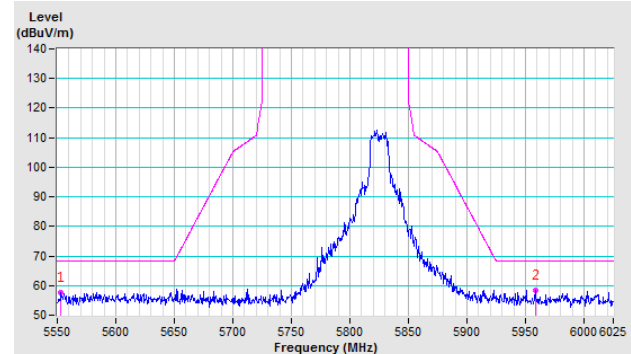

802.11ac (VHT20)

CH 149 5745 MHz

Horizontal

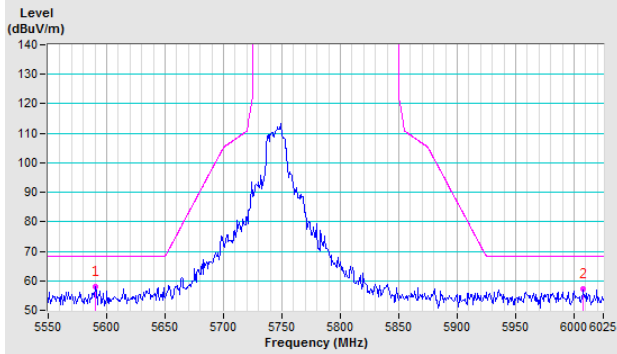

Vertical

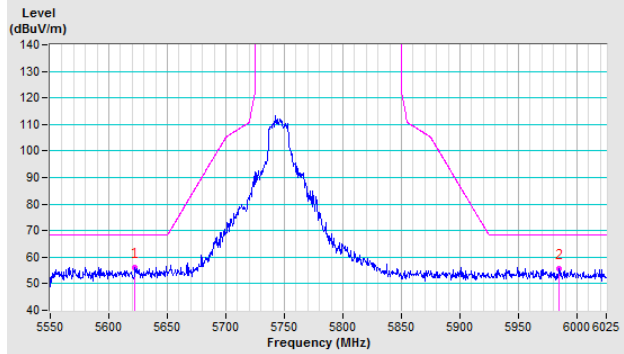

CH 157 5785 MHz

Horizontal

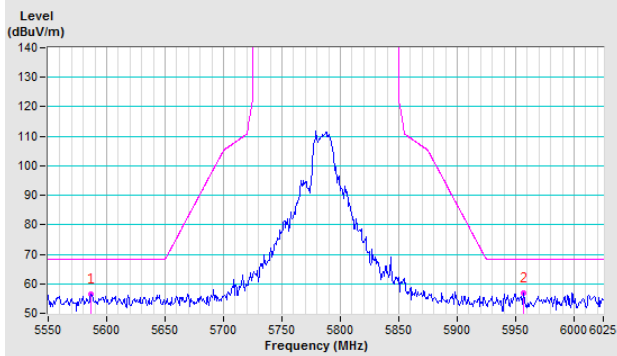

Vertical

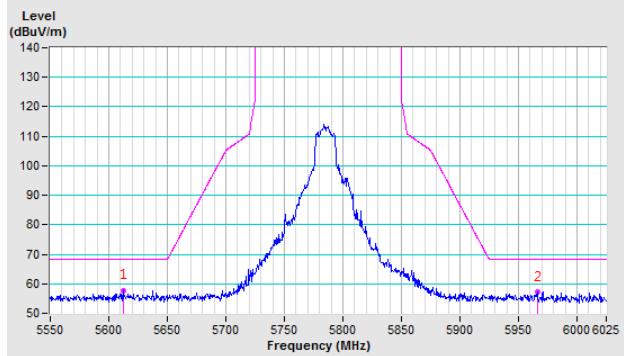

CH 165 5825 MHz

Horizontal

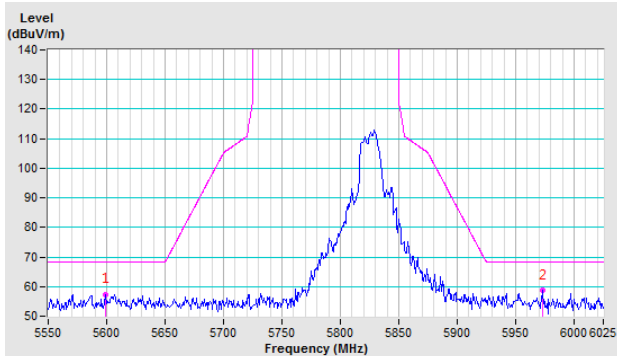

Vertical

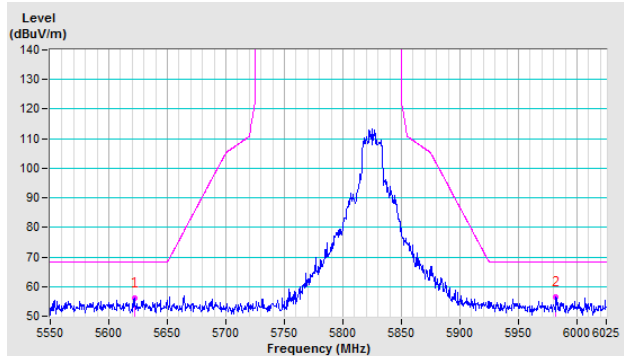

802.11ac (VHT40)

CH 151 5755 MHz

Horizontal

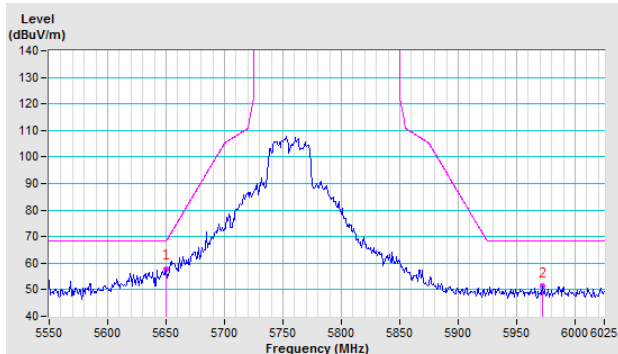

Vertical

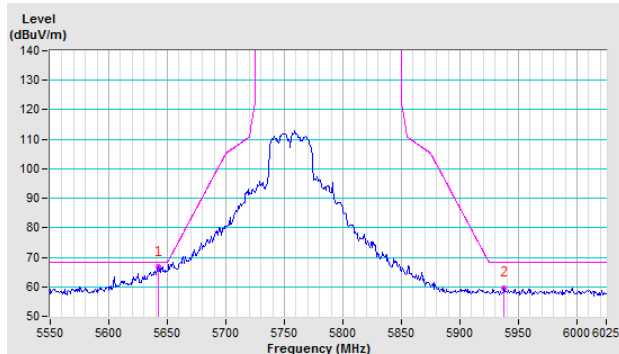

CH 159 5795 MHz

Horizontal

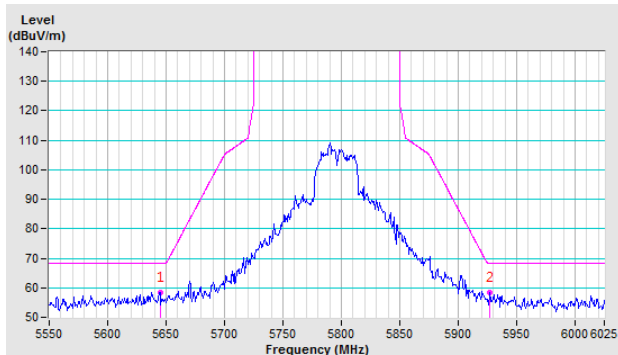

Vertical

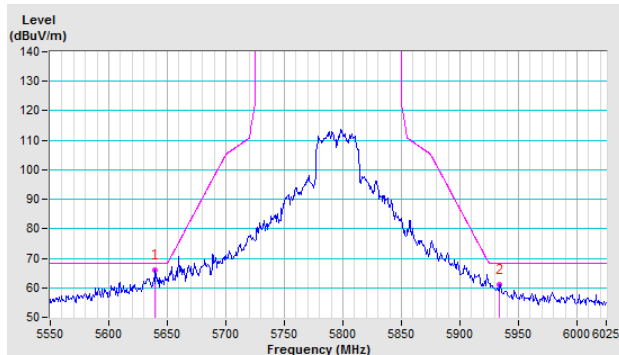

802.11ac (VHT80)

CH 155 5775 MHz

Horizontal

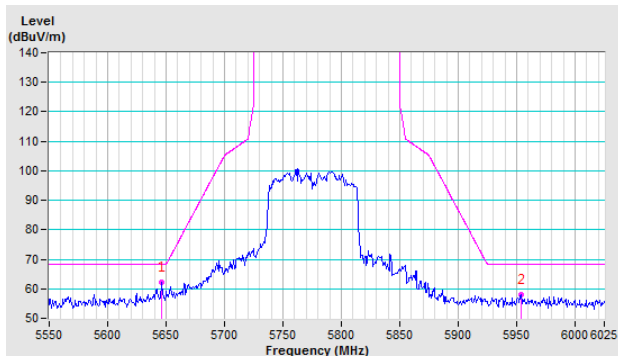

Vertical

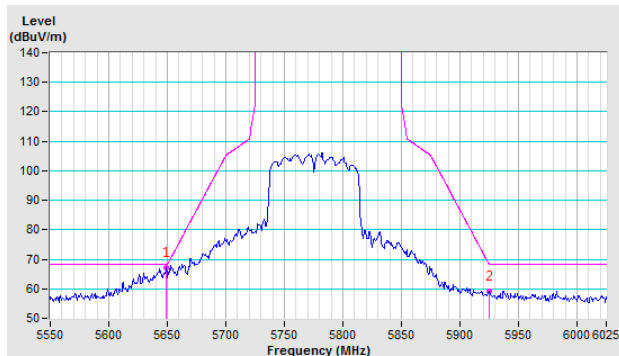

Appendix – Information on the Testing Laboratories

We, Bureau Veritas Consumer Products Services (H.K.) Ltd., Taoyuan Branch, were founded in 1988 to provide our best service in EMC, Radio, Telecom and Safety consultation. Our laboratories are accredited and approved according to ISO/IEC 17025.

If you have any comments, please feel free to contact us at the following:

Linko EMC/RF Lab

Tel: 886-2-26052180

Fax: 886-2-26051924

Hsin Chu EMC/RF/Telecom Lab

Tel: 886-3-6668565

Fax: 886-3-6668323

Hwa Ya EMC/RF/Safety Lab

Tel: 886-3-3183232

Fax: 886-3-3270892

Email: service.adt@tw.bureauveritas.com

Web Site: www.bureauveritas-adt.com

The address and road map of all our labs can be found in our web site also.

--- END ---