

FCC Test Report (WLAN)

Report No.: RF170209C07

FCC ID: 2AAEDWP2117

Test Model: WiCS-2100

Received Date: Feb. 09, 2017

Test Date: Mar. 03 to 16, 2017

Issued Date: Mar. 29, 2016

Applicant: Barco NV

Address: President Kennedypark 35, 8500 Kortrijk, Belgium

Issued By: Bureau Veritas Consumer Products Services (H.K.) Ltd., Taoyuan Branch
Hsin Chu Laboratory

Lab Address: E-2, No.1, Li Hsin 1st Road, Hsinchu Science Park, Hsinchu City 300,
Taiwan R.O.C.

Test Location (1): E-2, No.1, Li Hsin 1st Road, Hsinchu Science Park, Hsinchu City 300,
Taiwan R.O.C.

Test Location (2): No. 49, Ln. 206, Wende Rd., Shangshan Tsuen, Chiung Lin Hsiang, Hsin
Chu Hsien 307, Taiwan R.O.C.



This report is for your exclusive use. Any copying or replication of this report to or for any other person or entity, or use of our name or trademark, is permitted only with our prior written permission. This report sets forth our findings solely with respect to the test samples identified herein. The results set forth in this report are not indicative or representative of the quality or characteristics of the lot from which a test sample was taken or any similar or identical product unless specifically and expressly noted. Our report includes all of the tests requested by you and the results thereof based upon the information that you provided to us. You have 60 days from date of issuance of this report to notify us of any material error or omission caused by our negligence, provided, however, that such notice shall be in writing and shall specifically address the issue you wish to raise. A failure to raise such issue within the prescribed time shall constitute your unqualified acceptance of the completeness of this report, the tests conducted and the correctness of the report contents. Unless specific mention, the uncertainty of measurement has been explicitly taken into account to declare the compliance or non-compliance to the specification. The report must not be used by the client to claim product certification, approval, or endorsement by TAF or any government agencies.

Table of Contents

Release Control Record	4
1 Certificate of Conformity	5
2 Summary of Test Results	6
2.1 Measurement Uncertainty	6
2.2 Modification Record	6
3 General Information	7
3.1 General Description of EUT	7
3.2 Description of Test Modes	9
3.2.1 Test Mode Applicability and Tested Channel Detail	10
3.3 Duty Cycle of Test Signal	12
3.4 Description of Support Units	13
3.4.1 Configuration of System under Test	14
3.5 General Description of Applied Standards	16
4 Test Types and Results	17
4.1 Radiated Emission and Bandedge Measurement	17
4.1.1 Limits of Radiated Emission and Bandedge Measurement	17
4.1.2 Test Instruments	18
4.1.3 Test Procedures	19
4.1.4 Deviation from Test Standard	19
4.1.5 Test Setup	20
4.1.6 EUT Operating Conditions	21
4.1.7 Test Results	22
4.2 Conducted Emission Measurement	35
4.2.1 Limits of Conducted Emission Measurement	35
4.2.2 Test Instruments	35
4.2.3 Test Procedures	36
4.2.4 Deviation from Test Standard	36
4.2.5 Test Setup	36
4.2.6 EUT Operating Conditions	36
4.2.7 Test Results (Mode 1)	37
4.2.8 Test Results (Mode 2)	39
4.3 6dB Bandwidth Measurement	41
4.3.1 Limits of 6dB Bandwidth Measurement	41
4.3.2 Test Setup	41
4.3.3 Test Instruments	41
4.3.4 Test Procedure	41
4.3.5 Deviation from Test Standard	41
4.3.6 EUT Operating Conditions	41
4.3.7 Test Result	42
4.4 Conducted Output Power Measurement	44
4.4.1 Limits of Conducted Output Power Measurement	44
4.4.2 Test Setup	44
4.4.3 Test Instruments	44
4.4.4 Test Procedures	44
4.4.5 Deviation from Test Standard	44
4.4.6 EUT Operating Conditions	44
4.4.7 Test Results	45
4.5 Power Spectral Density Measurement	47
4.5.1 Limits of Power Spectral Density Measurement	47
4.5.2 Test Setup	47
4.5.3 Test Instruments	47
4.5.4 Test Procedure	47
4.5.5 Deviation from Test Standard	47

4.5.6 EUT Operating Condition	47
4.5.7 Test Results	48
4.6 Conducted Out of Band Emission Measurement	51
4.6.1 Limits of Conducted Out of Band Emission Measurement.....	51
4.6.2 Test Setup.....	51
4.6.3 Test Instruments	51
4.6.4 Test Procedure	51
4.6.5 Deviation from Test Standard	51
4.6.6 EUT Operating Condition	51
4.6.7 Test Results	51
5 Pictures of Test Arrangements.....	60
Appendix – Information on the Testing Laboratories	61

Release Control Record

Issue No.	Description	Date Issued
RF170209C07	Original release.	Mar. 29, 2016

1 Certificate of Conformity

Product: WiCS-2100

Brand: wePresent

Test Model: WiCS-2100

Sample Status: ENGINEERING SAMPLE

Applicant: Barco NV

Test Date: Mar. 03 to 16, 2017

Standards: 47 CFR FCC Part 15, Subpart C (Section 15.247)
ANSI C63.10: 2013

The above equipment has been tested by **Bureau Veritas Consumer Products Services (H.K.) Ltd., Taoyuan Branch**, and found compliance with the requirement of the above standards. The test record, data evaluation & Equipment Under Test (EUT) configurations represented herein are true and accurate accounts of the measurements of the sample's EMC characteristics under the conditions specified in this report.

Prepared by : Wendy Wu , **Date:** Mar. 29, 2016
Wendy Wu / Specialist

Approved by : May Chen , **Date:** Mar. 29, 2016
May Chen / Manager

2 Summary of Test Results

47 CFR FCC Part 15, Subpart C (SECTION 15.247)			
FCC Clause	Test Item	Result	Remarks
15.207	AC Power Conducted Emission	PASS	Meet the requirement of limit. Minimum passing margin is -5.78dB at 0.38828MHz.
15.205 / 15.209 / 15.247(d)	Radiated Emissions and Band Edge Measurement	PASS	Meet the requirement of limit. Minimum passing margin is -0.1dB at 2390.00MHz, 2483.50MHz, 4924.00MHz.
15.247(d)	Antenna Port Emission	PASS	Meet the requirement of limit.
15.247(a)(2)	6dB bandwidth	PASS	Meet the requirement of limit.
15.247(b)	Conducted power	PASS	Meet the requirement of limit.
15.247(e)	Power Spectral Density	PASS	Meet the requirement of limit.
15.203	Antenna Requirement	PASS	No antenna connector is used.

2.1 Measurement Uncertainty

Where relevant, the following measurement uncertainty levels have been estimated for tests performed on the EUT as specified in CISPR 16-4-2:

Measurement	Frequency	Expanded Uncertainty (k=2) (\pm)
Conducted Emissions at mains ports	150kHz ~ 30MHz	1.84 dB
Radiated Emissions up to 1 GHz	30MHz ~ 1GHz	5.34 dB
Radiated Emissions above 1 GHz	1GHz ~ 6GHz	3.41 dB
	6GHz ~ 18GHz	3.49 dB
	18GHz ~ 40GHz	3.30 dB

2.2 Modification Record

There were no modifications required for compliance.

3 General Information

3.1 General Description of EUT

Product	WiCS-2100
Brand	wePresent
Test Model	WiCS-2100
Status of EUT	ENGINEERING SAMPLE
Power Supply Rating	12Vdc from power adapter or 48Vdc from POE
Modulation Type	CCK, DQPSK, DBPSK for DSSS 64QAM, 16QAM, QPSK, BPSK for OFDM 256QAM for OFDM in 11ac mode only
Modulation Technology	DSSS, OFDM
Transfer Rate	802.11b: up to 11Mbps 802.11a/g: up to 54Mbps 802.11n: up to 300Mbps 802.11ac: up to 866.7Mbps
Operating Frequency	2.4GHz: 2.412 ~ 2.462GHz 5GHz: 5.18 ~ 5.24GHz, 5.745 ~ 5.825GHz
Number of Channel	2.4GHz: 802.11b, 802.11g, 802.11n (HT20): 11 802.11n (HT40): 7 5GHz: 802.11a, 802.11n (HT20), 802.11ac (VHT20): 9 802.11n (HT40), 802.11ac (VHT40): 4 802.11ac (VHT80): 2
Output Power	2.4GHz: 793.232mW 5.18 ~ 5.24GHz: 123.749mW 5.745 ~ 5.825GHz: 149.142mW
Antenna Type	Refer to Note
Antenna Connector	Refer to Note
Accessory Device	Adapter x 1, USB dongle x 1
Data Cable Supplied	NA

Note:

1. Simultaneously transmission condition.

Condition	Technology	
1	WLAN 2.4GHz	Bluetooth
2	WLAN 5GHz	Bluetooth

Note: The emission of the simultaneous operation has been evaluated and no non-compliance was found.

2. The EUT must be supplied with a power adapter or POE as following table:

Adapter		
Brand	Model No.	Spec.
APD	WA-24Q12R	Input: 100-240Vac, 0.7A, 50-60Hz Output: 12V, 2A DC output cable(unshielded, 1.5m)

POE (only for test, ont for sale)

Brand	Model No.	Spec.
PowerDsine	PD-3501G/AC	48Vdc

Note: From the above adapter and POE, the worst radiated test was found in **Adapter**. Therefore only the test data of the modes were recorded in this report.

3. The USB dongle is provided for the EUT as following table:

Brand	Model No.
wePresent	MH301

4. The antennas provided to the EUT, please refer to the following table:

For 2.4GHz & BT					
Antenna No.	Brand	Model	Antenna Net. Gain(dBi)	Frequency range (GHz)	Antenna Type
1 (Main-WLAN+BT combo Ant)	Pegatron Corp.	Pegatron P/N: 1415- 05VU000 (Hong-Bo P/N: 290- 30536)	2.85	2.4~2.4835	PCB
2 (Aux-WLAN Ant)			1.76	2.4~2.4835	
For 5GHz					
Antenna No.	Brand	Model	Antenna Net. Gain(dBi)	Frequency range (GHz)	Antenna Type
1 (Main-WLAN Ant)	Pegatron Corp.	Pegatron P/N: 1415- 05VU000 (Hong-Bo P/N: 290- 30536)	2.58	5.15~5.25	PCB
			3.37	5.25~5.35	
			3.68	5.47~5.725	
			3.58	5.725~5850	
2 (Aux-WLAN Ant)	Pegatron Corp.	Pegatron P/N: 1415-05VT000 (Hong-Bo P/N: 290- 30535)	2.76	5.15~5.25	PCB
			3.4	5.25~5.35	
			3.26	5.47~5.725	
			2.07	5.725~5850	

5. The EUT incorporates a MIMO function.

2.4GHz Band		
MODULATION MODE	DATA RATE (MCS)	TX & RX CONFIGURATION
802.11b	1 ~ 11Mbps	2TX 2RX
802.11g	6 ~ 54Mbps	2TX 2RX
802.11n (HT20)	MCS 0~7	2TX 2RX
	MCS 8~15	2TX 2RX
802.11n (HT40)	MCS 0~7	2TX 2RX
	MCS 8~15	2TX 2RX
5GHz Band		
MODULATION MODE	DATA RATE (MCS)	TX & RX CONFIGURATION
802.11a	6 ~ 54Mbps	2TX 2RX
802.11n (HT20)	MCS 0~7	2TX 2RX
	MCS 8~15	2TX 2RX
802.11n (HT40)	MCS 0~7	2TX 2RX
	MCS 8~15	2TX 2RX
802.11ac (VHT20)	MCS0~8 Nss=1	2TX 2RX
	MCS0~8 Nss=2	2TX 2RX
802.11ac (VHT40)	MCS0~9 Nss=1	2TX 2RX
	MCS0~9 Nss=2	2TX 2RX
802.11ac (VHT80)	MCS0~9 Nss=1	2TX 2RX
	MCS0~9 Nss=2	2TX 2RX

6. The above EUT information is declared by manufacturer and for more detailed features description, please refer to the manufacturer's specifications or user's manual.

3.2 Description of Test Modes

11 channels are provided for 802.11b, 802.11g and 802.11n (HT20):

Channel	Frequency	Channel	Frequency
1	2412MHz	7	2442MHz
2	2417MHz	8	2447MHz
3	2422MHz	9	2452MHz
4	2427MHz	10	2457MHz
5	2432MHz	11	2462MHz
6	2437MHz		

7 channels are provided for 802.11n (HT40):

Channel	Frequency	Channel	Frequency
3	2422MHz	7	2442MHz
4	2427MHz	8	2447MHz
5	2432MHz	9	2452MHz
6	2437MHz		

3.2.1 Test Mode Applicability and Tested Channel Detail

EUT CONFIGURE MODE	APPLICABLE TO				DESCRIPTION
	RE \geq 1G	RE $<$ 1G	PLC	APCM	
1	√	√	√	√	With adapter
2	-	-	√	-	With POE

Where RE \geq 1G: Radiated Emission above 1GHz & Bandedge Measurement
 RE $<$ 1G: Radiated Emission below 1GHz
 PLC: Power Line Conducted Emission
 APCM: Antenna Port Conducted Measurement

NOTE: The EUT had been pre-tested on the positioned of each 2 axis. The worst case was found when positioned on **X-plane**.

Radiated Emission Test (Above 1GHz):

- Pre-Scan has been conducted to determine the worst-case mode from all possible combinations between available modulations, data rates and antenna ports (if EUT with antenna diversity architecture).
- Following channel(s) was (were) selected for the final test as listed below.

MODE	AVAILABLE CHANNEL	TESTED CHANNEL	MODULATION TECHNOLOGY	MODULATION TYPE	DATA RATE (Mbps)
802.11b	1 to 11	1, 6, 11	DSSS	DBPSK	1
802.11g	1 to 11	1, 6, 11	OFDM	BPSK	6
802.11n (HT20)	1 to 11	1, 6, 11	OFDM	BPSK	6.5
802.11n (HT40)	3 to 9	3, 6, 9	OFDM	BPSK	13.5

Radiated Emission Test (Below 1GHz):

- Pre-Scan has been conducted to determine the worst-case mode from all possible combinations between available modulations, data rates and antenna ports (if EUT with antenna diversity architecture).
- Following channel(s) was (were) selected for the final test as listed below.

MODE	AVAILABLE CHANNEL	TESTED CHANNEL	MODULATION TECHNOLOGY	MODULATION TYPE	DATA RATE (Mbps)
802.11g	1 to 11	6	OFDM	BPSK	6

Power Line Conducted Emission Test:

- Pre-Scan has been conducted to determine the worst-case mode from all possible combinations between available modulations, data rates and antenna ports (if EUT with antenna diversity architecture).
- Following channel(s) was (were) selected for the final test as listed below.

MODE	AVAILABLE CHANNEL	TESTED CHANNEL	MODULATION TECHNOLOGY	MODULATION TYPE	DATA RATE (Mbps)
802.11g	1 to 11	6	OFDM	BPSK	6

Antenna Port Conducted Measurement:

- This item includes all test value of each mode, but only includes spectrum plot of worst value of each mode.
- Pre-Scan has been conducted to determine the worst-case mode from all possible combinations between available modulations, data rates and antenna ports (if EUT with antenna diversity architecture).
- Following channel(s) was (were) selected for the final test as listed below.

MODE	AVAILABLE CHANNEL	TESTED CHANNEL	MODULATION TECHNOLOGY	MODULATION TYPE	DATA RATE (Mbps)
802.11b	1 to 11	1, 6, 11	DSSS	DBPSK	1
802.11g	1 to 11	1, 6, 11	OFDM	BPSK	6
802.11n (HT20)	1 to 11	1, 6, 11	OFDM	BPSK	6.5
802.11n (HT40)	3 to 9	3, 6, 9	OFDM	BPSK	13.5

Test Condition:

APPLICABLE TO	ENVIRONMENTAL CONDITIONS	INPUT POWER	TESTED BY
RE \geq 1G	23deg. C, 66%RH	120Vac, 60Hz	Weiwei Lo
RE $<$ 1G	23deg. C, 66%RH	120Vac, 60Hz	Terry Huang
PLC	25deg. C, 75%RH	120Vac, 60Hz	Andy Ho
APCM	25deg. C, 60%RH	120Vac, 60Hz	Anderson Chen

3.3 Duty Cycle of Test Signal

If duty cycle of test signal is $\geq 98\%$, duty factor is not required.

802.11b: Duty cycle = $128.4/128.65 = 0.998$

802.11g: Duty cycle = $21.494/21.619 = 0.994$

802.11n (HT20): Duty cycle = $19.863/19.994 = 0.993$

802.11n (HT40): Duty cycle = $9.533/9.635 = 0.989$

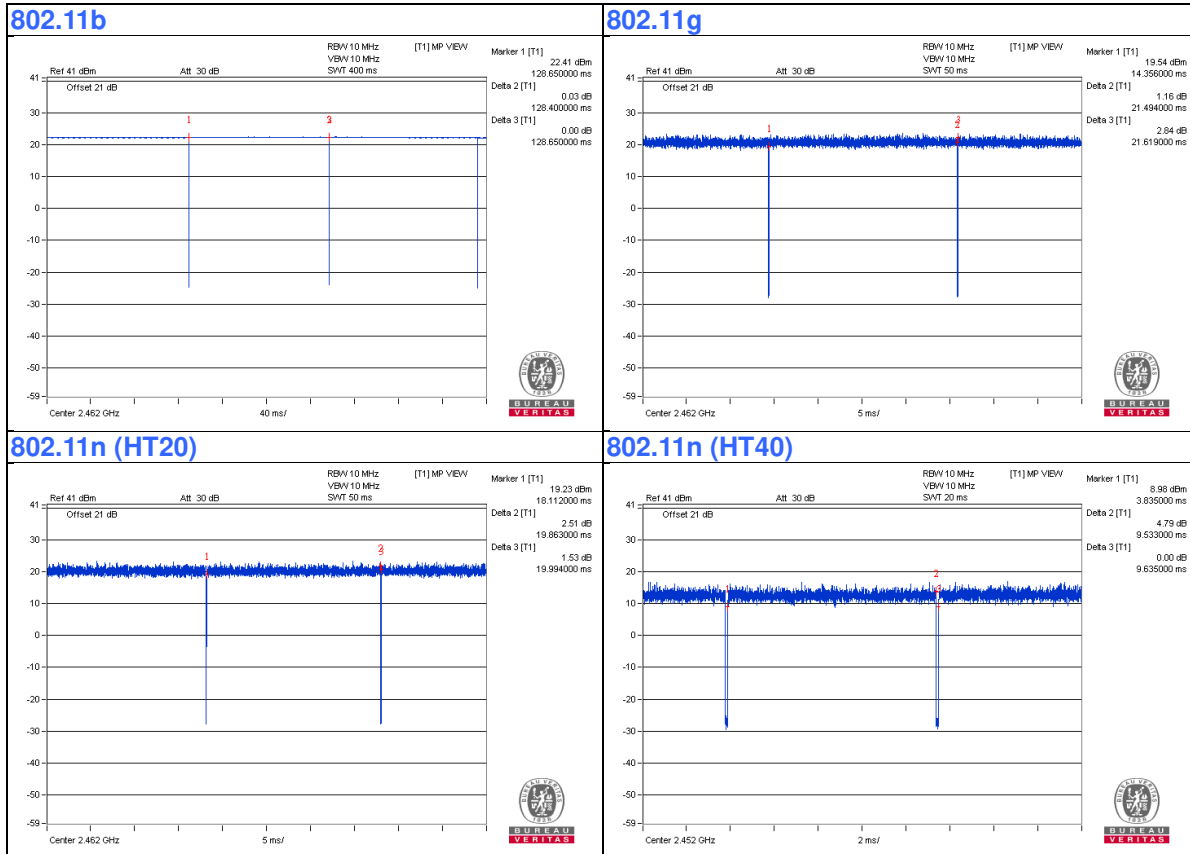

3.4 Description of Support Units

The EUT has been tested as an independent unit together with other necessary accessories or support units. The following support units or accessories were used to form a representative test configuration during the tests.

ID	Product	Brand	Model No.	Serial No.	FCC ID	Remarks
A.	Laptop	DELL	E5430	HYV4VY1	FCC DoC	Provided by Lab
B.	Monitor	ASUS	VS247	NA	NA	Provided by Lab
C.	PoE Adapter	PowerDsine	PD-3501G/AC	NA	NA	Provided by Lab
D.	Mouse	DELL	MS111-P	NA	NA	Provided by Lab

Note:

1. All power cords of the above support units are non-shielded (1.8m).

ID	Descriptions	Qty.	Length (m)	Shielding (Yes/No)	Cores (Qty.)	Remarks
1.	DC Cable	1	1.5	No	0	Supplied by client
2.	RJ-45 Cable	1	10	No	0	Provided by Lab
3.	Audio Cable	1	1.8	No	0	Provided by Lab
4.	HDMI Cable	1	3	Yes	0	Provided by Lab
5.	AC Cable	1	1.8	No	0	Provided by Lab
6.	RJ-45 Cable	1	3	No	0	Provided by Lab
7.	USB Cable	1	1.8	Yes	0	Provided by Lab

3.4.1 Configuration of System under Test

Mode 1:

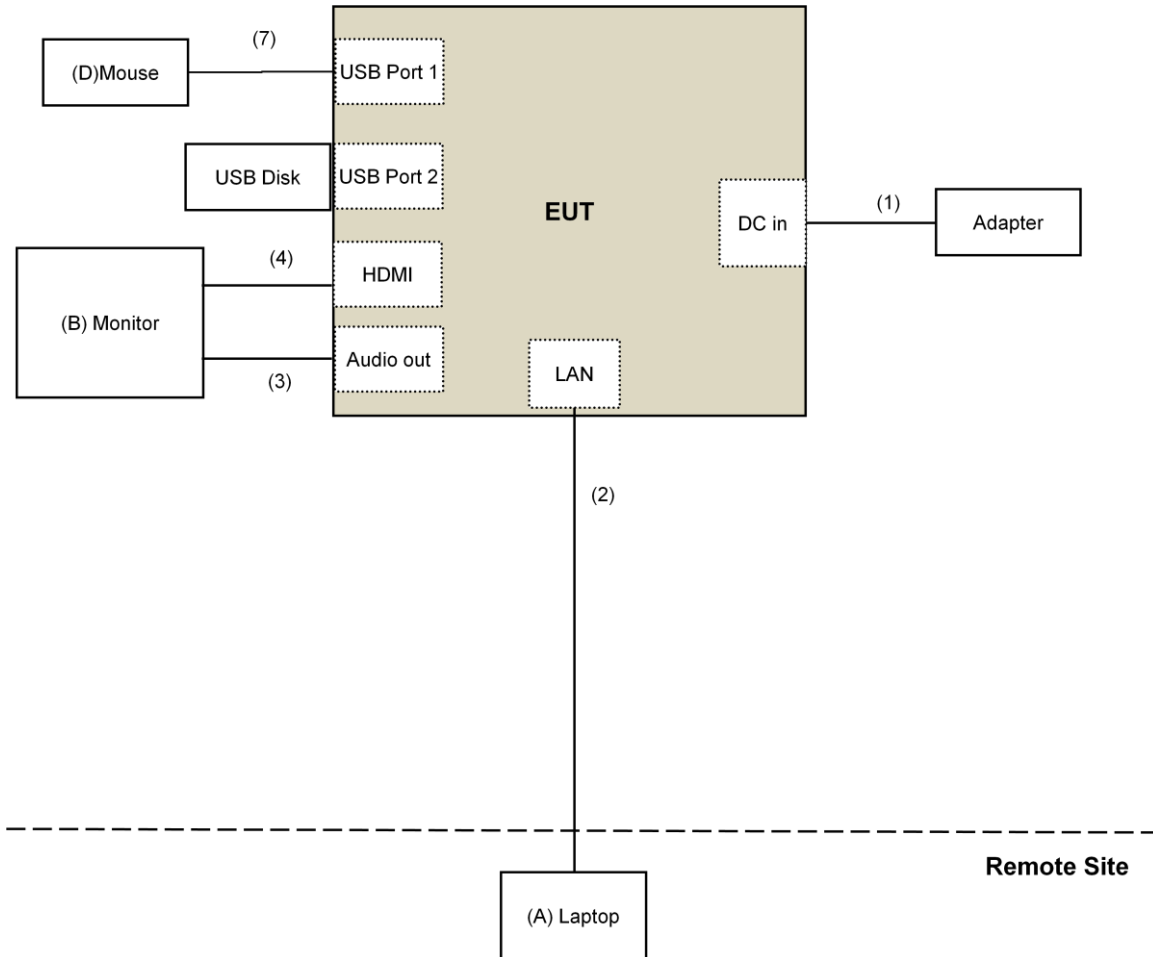

Mode 2:

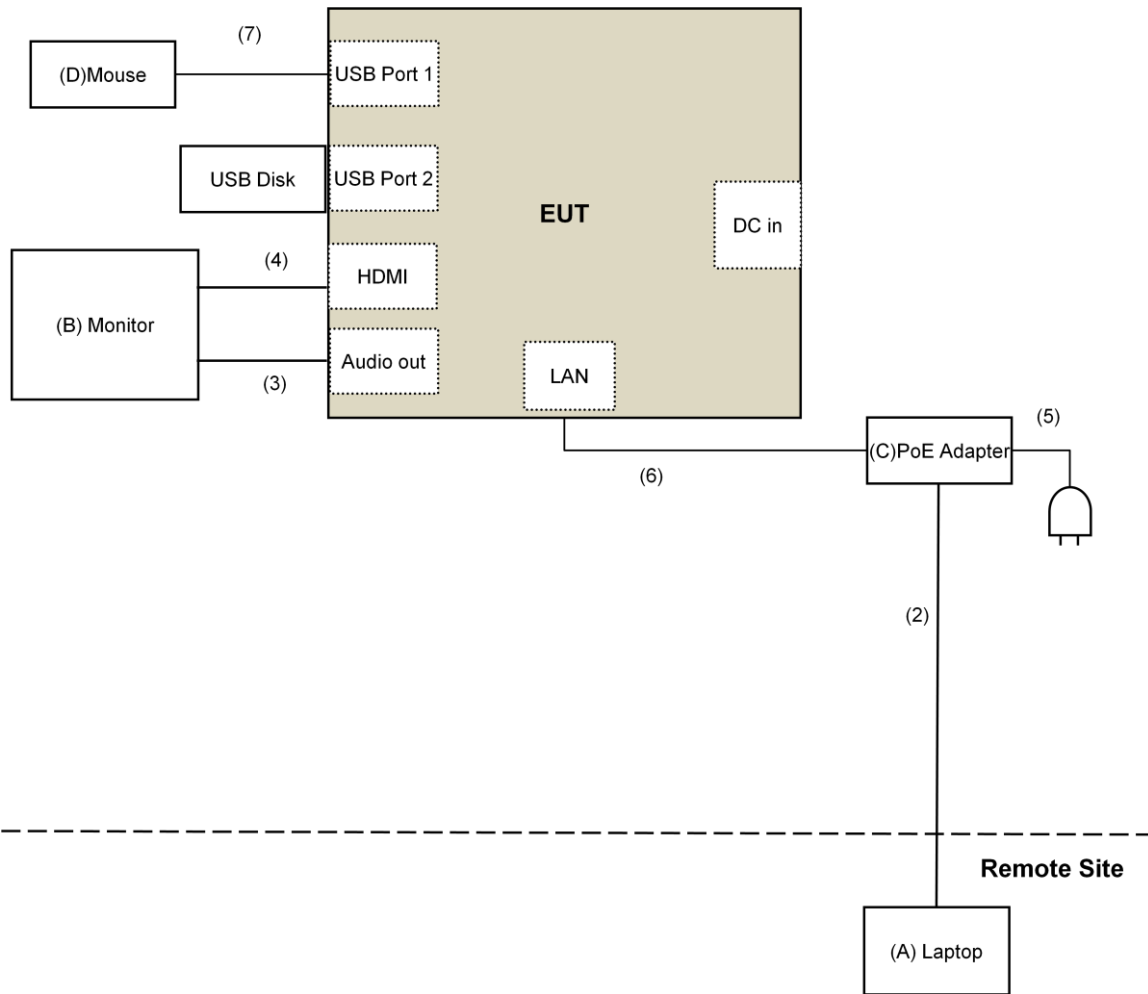

3.5 General Description of Applied Standards

The EUT is a RF Product. According to the specifications of the manufacturer, it must comply with the requirements of the following standards:

FCC Part 15, Subpart C (15.247)
KDB 558074 D01 DTS Meas Guidance v03r05
KDB 662911 D01 Multiple Transmitter Output v02r01
ANSI C63.10-2013

All test items have been performed and recorded as per the above standards.

NOTE: The EUT has been verified to comply with the requirements of FCC Part 15, Subpart B, Class B (DoC). The test report has been issued separately.

4 Test Types and Results

4.1 Radiated Emission and Bandedge Measurement

4.1.1 Limits of Radiated Emission and Bandedge Measurement

Radiated emissions which fall in the restricted bands must comply with the radiated emission limits specified as below table. Other emissions shall be at least 20dB below the highest level of the desired power:

Frequencies (MHz)	Field Strength (microvolts/meter)	Measurement Distance (meters)
0.009 ~ 0.490	2400/F(kHz)	300
0.490 ~ 1.705	24000/F(kHz)	30
1.705 ~ 30.0	30	30
30 ~ 88	100	3
88 ~ 216	150	3
216 ~ 960	200	3
Above 960	500	3

NOTE:

1. The lower limit shall apply at the transition frequencies.
2. Emission level (dBuV/m) = 20 log Emission level (uV/m).
3. For frequencies above 1000MHz, the field strength limits are based on average detector, however, the peak field strength of any emission shall not exceed the maximum permitted average limits, specified above by more than 20dB under any condition of modulation.

4.1.2 Test Instruments

DESCRIPTION & MANUFACTURER	MODEL NO.	SERIAL NO.	CALIBRATED DATE	CALIBRATED UNTIL
Test Receiver Keysight	N9038A	MY54450088	July 20, 2016	July 19, 2017
Pre-Amplifier ^(*) EMCI	EMC001340	980142	Jan. 20, 2016	Jan. 19, 2018
Loop Antenna ^(*) Electro-Metrics	EM-6879	264	Dec. 16, 2016	Dec. 15, 2018
RF Cable	NA	LOOPCAB-001 LOOPCAB-002	Jan. 17, 2017	Jan. 16, 2018
Pre-Amplifier Mini-Circuits	ZFL-1000VH2B	AMP-ZFL-01	Nov. 10, 2016	Nov. 09, 2017
Trilog Broadband Antenna SCHWARZBECK	VULB 9168	9168-406	Dec. 13, 2016	Dec. 12, 2017
RF Cable	8D	966-4-1 966-4-2 966-4-3	Apr. 02, 2016	Apr. 01, 2017
Fixed attenuator Mini-Circuits	UNAT-5+	PAD-3m-4-01	Oct. 05, 2016	Oct. 04, 2017
Horn_Antenna SCHWARZBECK	BBHA 9120D	9120D-783	Dec. 27, 2016	Dec. 26, 2017
Pre-Amplifier EMCI	EMC12630SE	980385	Feb. 02, 2017	Feb. 01, 2018
RF Cable	EMC104-SM-SM-2000 EMC104-SM-SM-5000 EMC104-SM-SM-5000	160923 150318 150323	Feb. 02, 2017 Mar. 30, 2016 Mar. 30, 2016	Feb. 01, 2018 Mar. 29, 2017 Mar. 29, 2017
Pre-Amplifier EMCI	EMC184045SE	980387	Feb. 02, 2017	Feb. 01, 2018
Horn_Antenna SCHWARZBECK	BBHA 9170	BBHA9170608	Dec. 15, 2016	Dec. 14, 2017
RF Cable	SUCOFLEX 102	36432/2 36433/2	Jan. 15, 2017	Jan. 14, 2018
Software	ADT_Radiated_V8.7.08	NA	NA	NA
Antenna Tower & Turn Table Max-Full	MF-7802	MF780208410	NA	NA
Boresight Antenna Fixture	FBA-01	FBA-SIP02	NA	NA
Spectrum Analyzer R&S	FSV40	100964	June 28, 2016	June 27, 2017
Power meter Anritsu	ML2495A	1014008	May 5, 2016	May 4, 2017
Power sensor Anritsu	MA2411B	0917122	May 5, 2016	May 4, 2017

Note:

1. The calibration interval of the above test instruments is 12 months and the calibrations are traceable to NML/ROC and NIST/USA.
2. *The calibration interval of the above test instruments is 24 months and the calibrations are traceable to NML/ROC and NIST/USA.
3. The test was performed in 966 Chamber No. 4.
4. The FCC Site Registration No. is 292998
5. The CANADA Site Registration No. is 20331-2
- 6 Loop antenna was used for all emissions below 30 MHz.
7. Tested Date: Mar. 08 to 09, 2017

4.1.3 Test Procedures

For Radiated emission below 30MHz

- a. The EUT was placed on the top of a rotating table 0.8 meters above the ground at a 3 meter chamber room. The table was rotated 360 degrees to determine the position of the highest radiation.
- b. The EUT was set 3 meters away from the interference-receiving antenna, which was mounted on the top of a variable-height antenna tower.
- c. Both X and Y axes of the antenna are set to make the measurement.
- d. For each suspected emission, the EUT was arranged to its worst case and the rotatable table was turned from 0 degrees to 360 degrees to find the maximum reading.
- e. The test-receiver system was set to Quasi-Peak Detect Function and Specified Bandwidth with Maximum Hold Mode.

NOTE:

1. The resolution bandwidth and video bandwidth of test receiver/spectrum analyzer is 9kHz at frequency below 30MHz.

For Radiated emission above 30MHz

- a. The EUT was placed on the top of a rotating table 0.8 meters (for 30MHz ~ 1GHz) / 1.5 meters (for above 1GHz) above the ground at 3 meter chamber room for test. The table was rotated 360 degrees to determine the position of the highest radiation.
- b. The EUT was set 3 meters away from the interference-receiving antenna, which was mounted on the top of a variable-height antenna tower.
- c. The height of antenna is varied from one meter to four meters above the ground to determine the maximum value of the field strength. Both horizontal and vertical polarizations of the antenna are set to make the measurement.
- d. For each suspected emission, the EUT was arranged to its worst case and then the antenna was tuned to heights from 1 meter to 4 meters and the rotatable table was turned from 0 degrees to 360 degrees to find the maximum reading.
- e. The test-receiver system was set to quasi-peak detect function and specified bandwidth with maximum hold mode when the test frequency is below 1 GHz.
- f. The test-receiver system was set to peak and average detect function and specified bandwidth with maximum hold mode when the test frequency is above 1 GHz. If the peak reading value also meets average limit, measurement with the average detector is unnecessary.

Note:

1. The resolution bandwidth and video bandwidth of test receiver/spectrum analyzer is 120kHz for Quasi-peak detection (QP) at frequency below 1GHz.
2. The resolution bandwidth of test receiver/spectrum analyzer is 1 MHz and the video bandwidth is 3 MHz for Peak detection (PK) at frequency above 1GHz.
3. The resolution bandwidth of test receiver/spectrum analyzer is 1MHz and the video bandwidth is $\geq 1/T$ (Duty cycle < 98%) or 10Hz (Duty cycle $\geq 98\%$) for Average detection (AV) at frequency above 1GHz.
4. All modes of operation were investigated and the worst-case emissions are reported.

4.1.4 Deviation from Test Standard

No deviation.

4.1.5 Test Setup

For Radiated emission below 30MHz

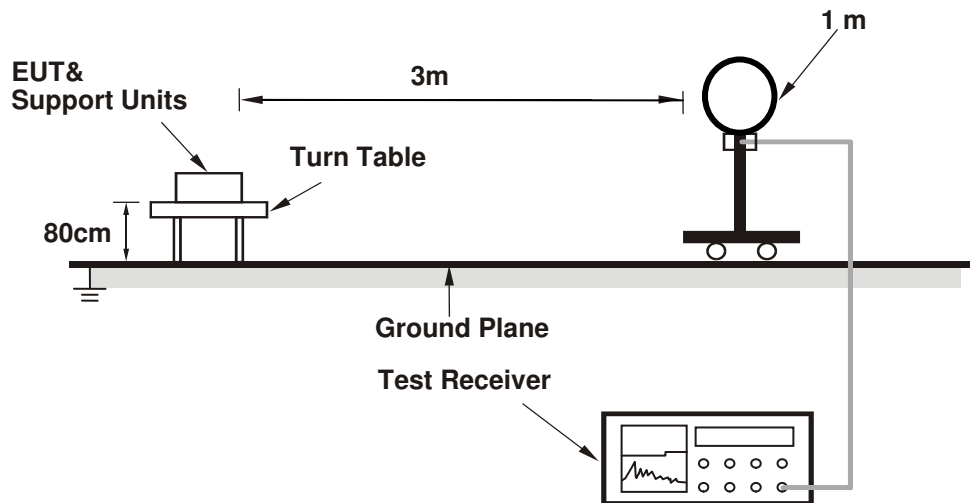

For Radiated emission 30MHz to 1GHz

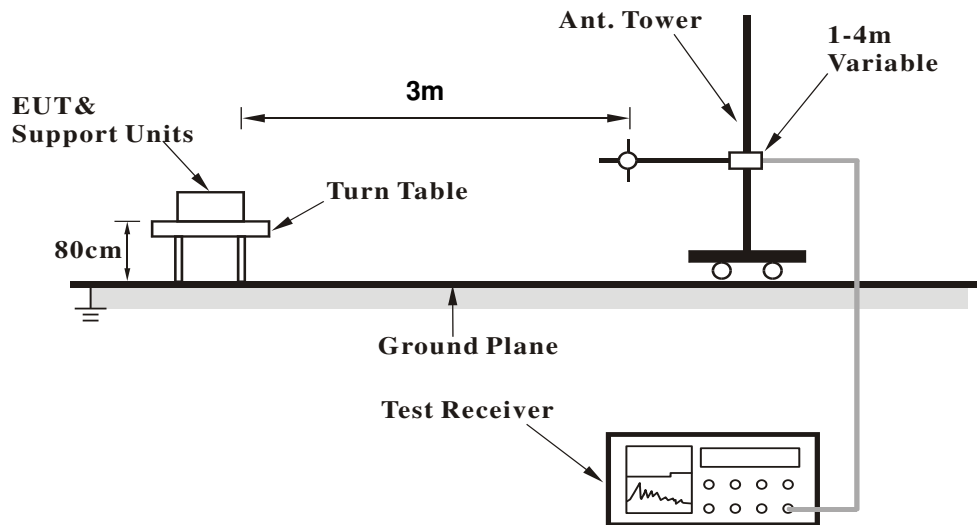

For Radiated emission above 1GHz

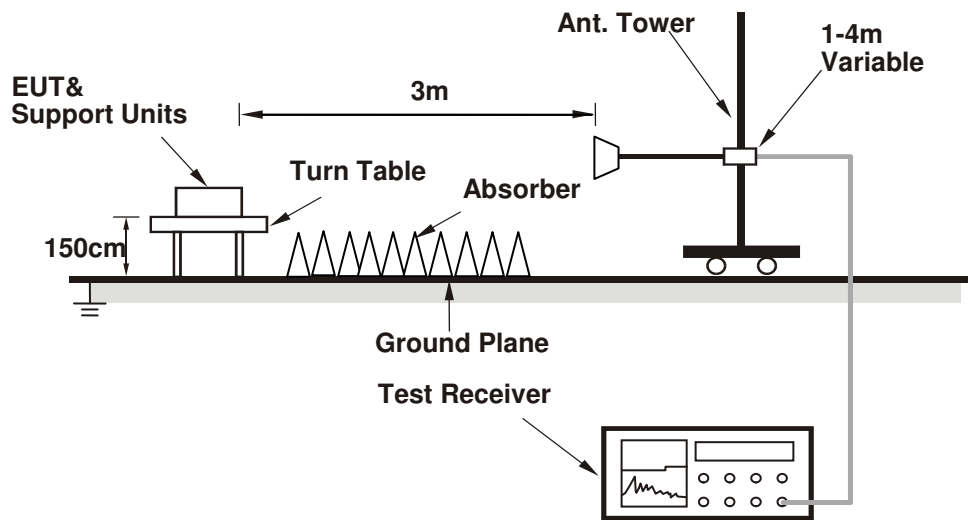

For the actual test configuration, please refer to the attached file (Test Setup Photo).

4.1.6 EUT Operating Conditions

- a. Connected the EUT with the Laptop which is placed on remote site.
- b. Controlling software (QRCT.EXE v3.0.197.0) has been activated to set the EUT on specific status.

4.1.7 Test Results

Above 1GHz Data:

802.11b

CHANNEL	TX Channel 1	DETECTOR FUNCTION	Peak (PK)
FREQUENCY RANGE	1GHz ~ 25GHz		Average (AV)

ANTENNA POLARITY & TEST DISTANCE: HORIZONTAL AT 3 M

NO.	FREQ. (MHz)	EMISSION LEVEL (dBuV/m)	LIMIT (dBuV/m)	MARGIN (dB)	ANTENNA HEIGHT (m)	TABLE ANGLE (Degree)	RAW VALUE (dBuV)	CORRECTION FACTOR (dB/m)
1	2390.00	52.8 PK	74.0	-21.2	1.12 H	231	54.9	-2.1
2	2390.00	42.2 AV	54.0	-11.8	1.12 H	231	44.3	-2.1
3	*2412.00	109.5 PK			1.12 H	231	111.5	-2.0
4	*2412.00	108.4 AV			1.12 H	231	110.4	-2.0
5	4824.00	53.6 PK	74.0	-20.4	1.49 H	276	51.4	2.2
6	4824.00	50.6 AV	54.0	-3.4	1.49 H	276	48.4	2.2

ANTENNA POLARITY & TEST DISTANCE: VERTICAL AT 3 M

NO.	FREQ. (MHz)	EMISSION LEVEL (dBuV/m)	LIMIT (dBuV/m)	MARGIN (dB)	ANTENNA HEIGHT (m)	TABLE ANGLE (Degree)	RAW VALUE (dBuV)	CORRECTION FACTOR (dB/m)
1	2390.00	54.9 PK	74.0	-19.1	2.63 V	211	57.0	-2.1
2	2390.00	43.9 AV	54.0	-10.1	2.63 V	211	46.0	-2.1
3	*2412.00	112.2 PK			2.63 V	211	114.2	-2.0
4	*2412.00	110.2 AV			2.63 V	211	112.2	-2.0
5	4824.00	54.5 PK	74.0	-19.5	1.25 V	118	52.3	2.2
6	4824.00	53.7 AV	54.0	-0.3	1.25 V	118	51.5	2.2

REMARKS:

1. Emission Level(dBuV/m) = Raw Value(dBuV) + Correction Factor(dB/m)
2. Correction Factor(dB/m) = Antenna Factor(dB/m) + Cable Factor(dB) – Pre-Amplifier Factor(dB)
3. The other emission levels were very low against the limit.
4. Margin value = Emission Level – Limit value
5. " * ": Fundamental frequency.

CHANNEL	TX Channel 6	DETECTOR FUNCTION	Peak (PK)
FREQUENCY RANGE	1GHz ~ 25GHz		Average (AV)

ANTENNA POLARITY & TEST DISTANCE: HORIZONTAL AT 3 M

NO.	FREQ. (MHz)	EMISSION LEVEL (dBuV/m)	LIMIT (dBuV/m)	MARGIN (dB)	ANTENNA HEIGHT (m)	TABLE ANGLE (Degree)	RAW VALUE (dBuV)	CORRECTION FACTOR (dB/m)
1	2390.00	51.6 PK	74.0	-22.4	1.09 H	248	53.7	-2.1
2	2390.00	40.8 AV	54.0	-13.2	1.09 H	248	42.9	-2.1
3	*2437.00	110.1 PK			1.09 H	248	112.1	-2.0
4	*2437.00	108.9 AV			1.09 H	248	110.9	-2.0
5	2483.50	55.1 PK	74.0	-18.9	1.09 H	248	56.9	-1.8
6	2483.50	47.5 AV	54.0	-6.5	1.09 H	248	49.3	-1.8
7	4874.00	54.1 PK	74.0	-19.9	1.50 H	268	51.8	2.3
8	4874.00	51.3 AV	54.0	-2.7	1.50 H	268	49.0	2.3
9	7311.00	44.3 PK	74.0	-29.7	1.63 H	351	35.7	8.6
10	7311.00	35.9 AV	54.0	-18.1	1.63 H	351	27.3	8.6

ANTENNA POLARITY & TEST DISTANCE: VERTICAL AT 3 M

NO.	FREQ. (MHz)	EMISSION LEVEL (dBuV/m)	LIMIT (dBuV/m)	MARGIN (dB)	ANTENNA HEIGHT (m)	TABLE ANGLE (Degree)	RAW VALUE (dBuV)	CORRECTION FACTOR (dB/m)
1	2390.00	53.3 PK	74.0	-20.7	2.49 V	209	55.4	-2.1
2	2390.00	42.3 AV	54.0	-11.7	2.49 V	209	44.4	-2.1
3	*2437.00	112.7 PK			2.49 V	209	114.7	-2.0
4	*2437.00	110.7 AV			2.49 V	209	112.7	-2.0
5	2483.50	57.7 PK	74.0	-16.3	2.49 V	209	59.5	-1.8
6	2483.50	48.5 AV	54.0	-5.5	2.49 V	209	50.3	-1.8
7	4874.00	55.2 PK	74.0	-18.8	1.16 V	144	52.9	2.3
8	4874.00	53.6 AV	54.0	-0.4	1.16 V	144	51.3	2.3
9	7311.00	46.5 PK	74.0	-27.5	1.82 V	230	37.9	8.6
10	7311.00	38.9 AV	54.0	-15.1	1.82 V	230	30.3	8.6

REMARKS:

1. Emission Level(dBuV/m) = Raw Value(dBuV) + Correction Factor(dB/m)
2. Correction Factor(dB/m) = Antenna Factor(dB/m) + Cable Factor(dB) – Pre-Amplifier Factor(dB)
3. The other emission levels were very low against the limit.
4. Margin value = Emission Level – Limit value
5. " * ": Fundamental frequency.

CHANNEL	TX Channel 11	DETECTOR FUNCTION	Peak (PK)
FREQUENCY RANGE	1GHz ~ 25GHz		Average (AV)

ANTENNA POLARITY & TEST DISTANCE: HORIZONTAL AT 3 M

NO.	FREQ. (MHz)	EMISSION LEVEL (dBuV/m)	LIMIT (dBuV/m)	MARGIN (dB)	ANTENNA HEIGHT (m)	TABLE ANGLE (Degree)	RAW VALUE (dBuV)	CORRECTION FACTOR (dB/m)
1	*2462.00	110.8 PK			1.00 H	205	112.7	-1.9
2	*2462.00	108.9 AV			1.00 H	205	110.8	-1.9
3	2483.50	58.7 PK	74.0	-15.3	1.00 H	205	60.5	-1.8
4	2483.50	50.1 AV	54.0	-3.9	1.00 H	205	51.9	-1.8
5	4924.00	54.5 PK	74.0	-19.5	1.47 H	260	52.0	2.5
6	4924.00	50.2 AV	54.0	-3.8	1.47 H	260	47.7	2.5
7	7386.00	43.7 PK	74.0	-30.3	1.60 H	354	35.1	8.6
8	7386.00	35.4 AV	54.0	-18.6	1.60 H	354	26.8	8.6

ANTENNA POLARITY & TEST DISTANCE: VERTICAL AT 3 M

NO.	FREQ. (MHz)	EMISSION LEVEL (dBuV/m)	LIMIT (dBuV/m)	MARGIN (dB)	ANTENNA HEIGHT (m)	TABLE ANGLE (Degree)	RAW VALUE (dBuV)	CORRECTION FACTOR (dB/m)
1	*2462.00	113.1 PK			2.36 V	210	115.0	-1.9
2	*2462.00	110.5 AV			2.36 V	210	112.4	-1.9
3	2483.50	60.2 PK	74.0	-13.8	2.36 V	210	62.0	-1.8
4	2483.50	50.2 AV	54.0	-3.8	2.36 V	210	52.0	-1.8
5	4924.00	55.1 PK	74.0	-18.9	1.32 V	136	52.6	2.5
6	4924.00	53.9 AV	54.0	-0.1	1.32 V	136	51.4	2.5
7	7386.00	46.7 PK	74.0	-27.3	1.80 V	223	38.1	8.6
8	7386.00	39.1 AV	54.0	-14.9	1.80 V	223	30.5	8.6

REMARKS:

1. Emission Level(dBuV/m) = Raw Value(dBuV) + Correction Factor(dB/m)
2. Correction Factor(dB/m) = Antenna Factor(dB/m) + Cable Factor(dB) – Pre-Amplifier Factor(dB)
3. The other emission levels were very low against the limit.
4. Margin value = Emission Level – Limit value
5. " * ": Fundamental frequency.

802.11g

CHANNEL	TX Channel 1	DETECTOR FUNCTION	Peak (PK)
FREQUENCY RANGE	1GHz ~ 25GHz		Average (AV)

ANTENNA POLARITY & TEST DISTANCE: HORIZONTAL AT 3 M

NO.	FREQ. (MHz)	EMISSION LEVEL (dBuV/m)	LIMIT (dBuV/m)	MARGIN (dB)	ANTENNA HEIGHT (m)	TABLE ANGLE (Degree)	RAW VALUE (dBuV)	CORRECTION FACTOR (dB/m)
1	2390.00	64.2 PK	74.0	-9.8	1.82 H	215	66.3	-2.1
2	2390.00	52.9 AV	54.0	-1.1	1.82 H	215	55.0	-2.1
3	*2412.00	111.5 PK			1.82 H	215	113.5	-2.0
4	*2412.00	102.3 AV			1.82 H	215	104.3	-2.0
5	4824.00	48.9 PK	74.0	-25.1	1.56 H	288	46.7	2.2
6	4824.00	44.4 AV	54.0	-9.6	1.56 H	288	42.2	2.2

ANTENNA POLARITY & TEST DISTANCE: VERTICAL AT 3 M

NO.	FREQ. (MHz)	EMISSION LEVEL (dBuV/m)	LIMIT (dBuV/m)	MARGIN (dB)	ANTENNA HEIGHT (m)	TABLE ANGLE (Degree)	RAW VALUE (dBuV)	CORRECTION FACTOR (dB/m)
1	2390.00	67.6 PK	74.0	-6.4	2.48 V	211	69.7	-2.1
2	2390.00	53.6 AV	54.0	-0.4	2.48 V	211	55.7	-2.1
3	*2412.00	112.5 PK			2.48 V	211	114.5	-2.0
4	*2412.00	103.2 AV			2.48 V	211	105.2	-2.0
5	4824.00	55.2 PK	74.0	-18.8	1.10 V	120	53.0	2.2
6	4824.00	45.5 AV	54.0	-8.5	1.10 V	120	43.3	2.2

REMARKS:

1. Emission Level(dBuV/m) = Raw Value(dBuV) + Correction Factor(dB/m)
2. Correction Factor(dB/m) = Antenna Factor(dB/m) + Cable Factor(dB) – Pre-Amplifier Factor(dB)
3. The other emission levels were very low against the limit.
4. Margin value = Emission Level – Limit value
5. " * ": Fundamental frequency.

CHANNEL	TX Channel 6	DETECTOR FUNCTION	Peak (PK)
FREQUENCY RANGE	1GHz ~ 25GHz		Average (AV)

ANTENNA POLARITY & TEST DISTANCE: HORIZONTAL AT 3 M

NO.	FREQ. (MHz)	EMISSION LEVEL (dBuV/m)	LIMIT (dBuV/m)	MARGIN (dB)	ANTENNA HEIGHT (m)	TABLE ANGLE (Degree)	RAW VALUE (dBuV)	CORRECTION FACTOR (dB/m)
1	2390.00	61.8 PK	74.0	-12.2	1.77 H	211	63.9	-2.1
2	2390.00	45.8 AV	54.0	-8.2	1.77 H	211	47.9	-2.1
3	*2437.00	115.8 PK			1.77 H	211	117.8	-2.0
4	*2437.00	106.8 AV			1.77 H	211	108.8	-2.0
5	2483.50	68.0 PK	74.0	-6.0	1.77 H	211	69.8	-1.8
6	2483.50	53.1 AV	54.0	-0.9	1.77 H	211	54.9	-1.8
7	4874.00	54.4 PK	74.0	-19.6	1.46 H	273	52.1	2.3
8	4874.00	49.9 AV	54.0	-4.1	1.46 H	273	47.6	2.3
9	7311.00	43.0 PK	74.0	-31.0	1.54 H	360	34.4	8.6
10	7311.00	35.0 AV	54.0	-19.0	1.54 H	360	26.4	8.6

ANTENNA POLARITY & TEST DISTANCE: VERTICAL AT 3 M

NO.	FREQ. (MHz)	EMISSION LEVEL (dBuV/m)	LIMIT (dBuV/m)	MARGIN (dB)	ANTENNA HEIGHT (m)	TABLE ANGLE (Degree)	RAW VALUE (dBuV)	CORRECTION FACTOR (dB/m)
1	2390.00	65.1 PK	74.0	-8.9	2.51 V	205	67.2	-2.1
2	2390.00	52.1 AV	54.0	-1.9	2.51 V	205	54.2	-2.1
3	*2437.00	117.5 PK			2.51 V	205	119.5	-2.0
4	*2437.00	108.1 AV			2.51 V	205	110.1	-2.0
5	2483.50	68.2 PK	74.0	-5.8	2.51 V	205	70.0	-1.8
6	2483.50	53.6 AV	54.0	-0.4	2.51 V	205	55.4	-1.8
7	4874.00	61.0 PK	74.0	-13.0	1.00 V	106	58.7	2.3
8	4874.00	51.1 AV	54.0	-2.9	1.00 V	106	48.8	2.3
9	7311.00	47.0 PK	74.0	-27.0	1.85 V	211	38.4	8.6
10	7311.00	39.5 AV	54.0	-14.5	1.85 V	211	30.9	8.6

REMARKS:

1. Emission Level(dBuV/m) = Raw Value(dBuV) + Correction Factor(dB/m)
2. Correction Factor(dB/m) = Antenna Factor(dB/m) + Cable Factor(dB) – Pre-Amplifier Factor(dB)
3. The other emission levels were very low against the limit.
4. Margin value = Emission Level – Limit value
5. " * ": Fundamental frequency.

CHANNEL	TX Channel 11	DETECTOR FUNCTION	Peak (PK)
FREQUENCY RANGE	1GHz ~ 25GHz		Average (AV)

ANTENNA POLARITY & TEST DISTANCE: HORIZONTAL AT 3 M

NO.	FREQ. (MHz)	EMISSION LEVEL (dBuV/m)	LIMIT (dBuV/m)	MARGIN (dB)	ANTENNA HEIGHT (m)	TABLE ANGLE (Degree)	RAW VALUE (dBuV)	CORRECTION FACTOR (dB/m)
1	*2462.00	110.8 PK			1.78 H	211	112.7	-1.9
2	*2462.00	101.3 AV			1.78 H	211	103.2	-1.9
3	2483.50	66.1 PK	74.0	-7.9	1.78 H	211	67.9	-1.8
4	2483.50	53.2 AV	54.0	-0.8	1.78 H	211	55.0	-1.8
5	4924.00	48.3 PK	74.0	-25.7	1.55 H	200	45.8	2.5
6	4924.00	43.8 AV	54.0	-10.2	1.55 H	200	41.3	2.5
7	7386.00	43.9 PK	74.0	-30.1	1.65 H	354	35.3	8.6
8	7386.00	35.5 AV	54.0	-18.5	1.65 H	354	26.9	8.6

ANTENNA POLARITY & TEST DISTANCE: VERTICAL AT 3 M

NO.	FREQ. (MHz)	EMISSION LEVEL (dBuV/m)	LIMIT (dBuV/m)	MARGIN (dB)	ANTENNA HEIGHT (m)	TABLE ANGLE (Degree)	RAW VALUE (dBuV)	CORRECTION FACTOR (dB/m)
1	*2462.00	112.4 PK			2.48 V	211	114.3	-1.9
2	*2462.00	102.7 AV			2.48 V	211	104.6	-1.9
3	2483.50	69.0 PK	74.0	-5.0	2.48 V	211	70.8	-1.8
4	2483.50	53.7 AV	54.0	-0.3	2.48 V	211	55.5	-1.8
5	4924.00	55.6 PK	74.0	-18.4	1.01 V	115	53.1	2.5
6	4924.00	45.5 AV	54.0	-8.5	1.01 V	115	43.0	2.5
7	7386.00	47.2 PK	74.0	-26.8	1.82 V	213	38.6	8.6
8	7386.00	39.4 AV	54.0	-14.6	1.82 V	213	30.8	8.6

REMARKS:

1. Emission Level(dBuV/m) = Raw Value(dBuV) + Correction Factor(dB/m)
2. Correction Factor(dB/m) = Antenna Factor(dB/m) + Cable Factor(dB) – Pre-Amplifier Factor(dB)
3. The other emission levels were very low against the limit.
4. Margin value = Emission Level – Limit value
5. " * ": Fundamental frequency.

802.11n (HT20)

CHANNEL	TX Channel 1	DETECTOR FUNCTION	Peak (PK)
FREQUENCY RANGE	1GHz ~ 25GHz		Average (AV)

ANTENNA POLARITY & TEST DISTANCE: HORIZONTAL AT 3 M

NO.	FREQ. (MHz)	EMISSION LEVEL (dBuV/m)	LIMIT (dBuV/m)	MARGIN (dB)	ANTENNA HEIGHT (m)	TABLE ANGLE (Degree)	RAW VALUE (dBuV)	CORRECTION FACTOR (dB/m)
1	2390.00	64.3 PK	74.0	-9.7	1.75 H	184	66.4	-2.1
2	2390.00	53.3 AV	54.0	-0.7	1.75 H	184	55.4	-2.1
3	*2412.00	110.2 PK			1.75 H	184	112.2	-2.0
4	*2412.00	101.5 AV			1.75 H	184	103.5	-2.0
5	4824.00	49.7 PK	74.0	-24.3	1.49 H	289	47.5	2.2
6	4824.00	45.1 AV	54.0	-8.9	1.49 H	289	42.9	2.2

ANTENNA POLARITY & TEST DISTANCE: VERTICAL AT 3 M

NO.	FREQ. (MHz)	EMISSION LEVEL (dBuV/m)	LIMIT (dBuV/m)	MARGIN (dB)	ANTENNA HEIGHT (m)	TABLE ANGLE (Degree)	RAW VALUE (dBuV)	CORRECTION FACTOR (dB/m)
1	2390.00	66.0 PK	74.0	-8.0	1.50 V	193	68.1	-2.1
2	2390.00	53.7 AV	54.0	-0.3	1.50 V	193	55.8	-2.1
3	*2412.00	111.9 PK			1.50 V	193	113.9	-2.0
4	*2412.00	103.1 AV			1.50 V	193	105.1	-2.0
5	4824.00	56.6 PK	74.0	-17.4	1.13 V	77	54.4	2.2
6	4824.00	46.8 AV	54.0	-7.2	1.13 V	77	44.6	2.2

REMARKS:

1. Emission Level(dBuV/m) = Raw Value(dBuV) + Correction Factor(dB/m)
2. Correction Factor(dB/m) = Antenna Factor(dB/m) + Cable Factor(dB) – Pre-Amplifier Factor(dB)
3. The other emission levels were very low against the limit.
4. Margin value = Emission Level – Limit value
5. " * ": Fundamental frequency.

CHANNEL	TX Channel 6	DETECTOR FUNCTION	Peak (PK)
FREQUENCY RANGE	1GHz ~ 25GHz		Average (AV)

ANTENNA POLARITY & TEST DISTANCE: HORIZONTAL AT 3 M

NO.	FREQ. (MHz)	EMISSION LEVEL (dBuV/m)	LIMIT (dBuV/m)	MARGIN (dB)	ANTENNA HEIGHT (m)	TABLE ANGLE (Degree)	RAW VALUE (dBuV)	CORRECTION FACTOR (dB/m)
1	2390.00	62.5 PK	74.0	-11.5	1.81 H	209	64.6	-2.1
2	2390.00	46.3 AV	54.0	-7.7	1.81 H	209	48.4	-2.1
3	*2437.00	113.8 PK			1.81 H	209	115.8	-2.0
4	*2437.00	104.6 AV			1.81 H	209	106.6	-2.0
5	2483.50	68.1 PK	74.0	-5.9	1.81 H	209	69.9	-1.8
6	2483.50	53.1 AV	54.0	-0.9	1.81 H	209	54.9	-1.8
7	4874.00	54.2 PK	74.0	-19.8	1.47 H	275	51.9	2.3
8	4874.00	49.6 AV	54.0	-4.4	1.47 H	275	47.3	2.3
9	7311.00	42.3 PK	74.0	-31.7	1.54 H	349	33.7	8.6
10	7311.00	34.6 AV	54.0	-19.4	1.54 H	349	26.0	8.6

ANTENNA POLARITY & TEST DISTANCE: VERTICAL AT 3 M

NO.	FREQ. (MHz)	EMISSION LEVEL (dBuV/m)	LIMIT (dBuV/m)	MARGIN (dB)	ANTENNA HEIGHT (m)	TABLE ANGLE (Degree)	RAW VALUE (dBuV)	CORRECTION FACTOR (dB/m)
1	2390.00	64.3 PK	74.0	-9.7	1.43 V	214	66.4	-2.1
2	2390.00	49.2 AV	54.0	-4.8	1.43 V	214	51.3	-2.1
3	*2437.00	115.5 PK			1.43 V	214	117.5	-2.0
4	*2437.00	106.1 AV			1.43 V	214	108.1	-2.0
5	2483.50	69.8 PK	74.0	-4.2	1.43 V	214	71.6	-1.8
6	2483.50	53.7 AV	54.0	-0.3	1.43 V	214	55.5	-1.8
7	4874.00	61.0 PK	74.0	-13.0	1.20 V	95	58.7	2.3
8	4874.00	51.0 AV	54.0	-3.0	1.20 V	95	48.7	2.3
9	7311.00	46.4 PK	74.0	-27.6	1.85 V	199	37.8	8.6
10	7311.00	39.0 AV	54.0	-15.0	1.85 V	199	30.4	8.6

REMARKS:

1. Emission Level(dBuV/m) = Raw Value(dBuV) + Correction Factor(dB/m)
2. Correction Factor(dB/m) = Antenna Factor(dB/m) + Cable Factor(dB) – Pre-Amplifier Factor(dB)
3. The other emission levels were very low against the limit.
4. Margin value = Emission Level – Limit value
5. " * ": Fundamental frequency.

CHANNEL	TX Channel 11	DETECTOR FUNCTION	Peak (PK)
FREQUENCY RANGE	1GHz ~ 25GHz		Average (AV)

ANTENNA POLARITY & TEST DISTANCE: HORIZONTAL AT 3 M

NO.	FREQ. (MHz)	EMISSION LEVEL (dBuV/m)	LIMIT (dBuV/m)	MARGIN (dB)	ANTENNA HEIGHT (m)	TABLE ANGLE (Degree)	RAW VALUE (dBuV)	CORRECTION FACTOR (dB/m)
1	*2462.00	110.1 PK			1.83 H	204	112.0	-1.9
2	*2462.00	101.3 AV			1.83 H	204	103.2	-1.9
3	2483.50	66.4 PK	74.0	-7.6	1.83 H	204	68.2	-1.8
4	2483.50	53.2 AV	54.0	-0.8	1.83 H	204	55.0	-1.8
5	4924.00	48.7 PK	74.0	-25.3	1.50 H	259	46.2	2.5
6	4924.00	44.2 AV	54.0	-9.8	1.50 H	259	41.7	2.5
7	7386.00	40.6 PK	74.0	-33.4	1.60 H	353	32.0	8.6
8	7386.00	31.8 AV	54.0	-22.2	1.60 H	353	23.2	8.6

ANTENNA POLARITY & TEST DISTANCE: VERTICAL AT 3 M

NO.	FREQ. (MHz)	EMISSION LEVEL (dBuV/m)	LIMIT (dBuV/m)	MARGIN (dB)	ANTENNA HEIGHT (m)	TABLE ANGLE (Degree)	RAW VALUE (dBuV)	CORRECTION FACTOR (dB/m)
1	*2462.00	111.8 PK			1.53 V	220	113.7	-1.9
2	*2462.00	102.6 AV			1.53 V	220	104.5	-1.9
3	2483.50	67.6 PK	74.0	-6.4	1.53 V	220	69.4	-1.8
4	2483.50	53.9 AV	54.0	-0.1	1.53 V	220	55.7	-1.8
5	4924.00	55.9 PK	74.0	-18.1	1.10 V	108	53.4	2.5
6	4924.00	45.7 AV	54.0	-8.3	1.10 V	108	43.2	2.5
7	7386.00	41.2 PK	74.0	-32.8	1.78 V	189	32.6	8.6
8	7386.00	33.7 AV	54.0	-20.3	1.78 V	189	25.1	8.6

REMARKS:

1. Emission Level(dBuV/m) = Raw Value(dBuV) + Correction Factor(dB/m)
2. Correction Factor(dB/m) = Antenna Factor(dB/m) + Cable Factor(dB) – Pre-Amplifier Factor(dB)
3. The other emission levels were very low against the limit.
4. Margin value = Emission Level – Limit value
5. " * ": Fundamental frequency.

802.11n (HT40)

CHANNEL	TX Channel 3	DETECTOR FUNCTION	Peak (PK)
FREQUENCY RANGE	1GHz ~ 25GHz		Average (AV)

ANTENNA POLARITY & TEST DISTANCE: HORIZONTAL AT 3 M

NO.	FREQ. (MHz)	EMISSION LEVEL (dBuV/m)	LIMIT (dBuV/m)	MARGIN (dB)	ANTENNA HEIGHT (m)	TABLE ANGLE (Degree)	RAW VALUE (dBuV)	CORRECTION FACTOR (dB/m)
1	2390.00	66.1 PK	74.0	-7.9	1.01 H	197	68.2	-2.1
2	2390.00	53.5 AV	54.0	-0.5	1.01 H	197	55.6	-2.1
3	*2422.00	104.6 PK			1.01 H	197	106.7	-2.1
4	*2422.00	96.2 AV			1.01 H	197	98.3	-2.1
5	4844.00	48.3 PK	74.0	-25.7	1.44 H	271	46.0	2.3
6	4844.00	44.2 AV	54.0	-9.8	1.44 H	271	41.9	2.3
7	7266.00	40.3 PK	74.0	-33.7	1.61 H	360	31.7	8.6
8	7266.00	31.7 AV	54.0	-22.3	1.61 H	360	23.1	8.6

ANTENNA POLARITY & TEST DISTANCE: VERTICAL AT 3 M

NO.	FREQ. (MHz)	EMISSION LEVEL (dBuV/m)	LIMIT (dBuV/m)	MARGIN (dB)	ANTENNA HEIGHT (m)	TABLE ANGLE (Degree)	RAW VALUE (dBuV)	CORRECTION FACTOR (dB/m)
1	2390.00	67.1 PK	74.0	-6.9	2.19 V	214	69.2	-2.1
2	2390.00	53.9 AV	54.0	-0.1	2.19 V	214	56.0	-2.1
3	*2422.00	106.1 PK			2.19 V	214	108.2	-2.1
4	*2422.00	97.3 AV			2.19 V	214	99.4	-2.1
5	4844.00	55.6 PK	74.0	-18.4	1.12 V	95	53.3	2.3
6	4844.00	45.4 AV	54.0	-8.6	1.12 V	95	43.1	2.3
7	7266.00	41.0 PK	74.0	-33.0	1.79 V	192	32.4	8.6
8	7266.00	33.3 AV	54.0	-20.7	1.79 V	192	24.7	8.6

REMARKS:

- Emission Level(dBuV/m) = Raw Value(dBuV) + Correction Factor(dB/m)
- Correction Factor(dB/m) = Antenna Factor(dB/m) + Cable Factor(dB) – Pre-Amplifier Factor(dB)
- The other emission levels were very low against the limit.
- Margin value = Emission Level – Limit value
- " * ": Fundamental frequency.

CHANNEL	TX Channel 6	DETECTOR FUNCTION	Peak (PK)
FREQUENCY RANGE	1GHz ~ 25GHz		Average (AV)

ANTENNA POLARITY & TEST DISTANCE: HORIZONTAL AT 3 M

NO.	FREQ. (MHz)	EMISSION LEVEL (dBuV/m)	LIMIT (dBuV/m)	MARGIN (dB)	ANTENNA HEIGHT (m)	TABLE ANGLE (Degree)	RAW VALUE (dBuV)	CORRECTION FACTOR (dB/m)
1	2390.00	60.4 PK	74.0	-13.6	1.04 H	205	62.5	-2.1
2	2390.00	48.0 AV	54.0	-6.0	1.04 H	205	50.1	-2.1
3	*2437.00	108.0 PK			1.04 H	205	110.0	-2.0
4	*2437.00	98.9 AV			1.04 H	205	100.9	-2.0
5	2483.50	68.1 PK	74.0	-5.9	1.04 H	205	69.9	-1.8
6	2483.50	53.6 AV	54.0	-0.4	1.04 H	205	55.4	-1.8
7	4874.00	48.5 PK	74.0	-25.5	1.53 H	274	46.2	2.3
8	4874.00	44.3 AV	54.0	-9.7	1.53 H	274	42.0	2.3
9	7311.00	40.6 PK	74.0	-33.4	1.55 H	349	32.0	8.6
10	7311.00	31.9 AV	54.0	-22.1	1.55 H	349	23.3	8.6

ANTENNA POLARITY & TEST DISTANCE: VERTICAL AT 3 M

NO.	FREQ. (MHz)	EMISSION LEVEL (dBuV/m)	LIMIT (dBuV/m)	MARGIN (dB)	ANTENNA HEIGHT (m)	TABLE ANGLE (Degree)	RAW VALUE (dBuV)	CORRECTION FACTOR (dB/m)
1	2390.00	61.7 PK	74.0	-12.3	2.38 V	209	63.8	-2.1
2	2390.00	50.1 AV	54.0	-3.9	2.38 V	209	52.2	-2.1
3	*2437.00	109.5 PK			2.38 V	209	111.5	-2.0
4	*2437.00	100.0 AV			2.38 V	209	102.0	-2.0
5	2483.50	69.3 PK	74.0	-4.7	2.38 V	209	71.1	-1.8
6	2483.50	53.9 AV	54.0	-0.1	2.38 V	209	55.7	-1.8
7	4874.00	55.9 PK	74.0	-18.1	1.11 V	103	53.6	2.3
8	4874.00	45.7 AV	54.0	-8.3	1.11 V	103	43.4	2.3
9	7311.00	40.6 PK	74.0	-33.4	1.78 V	186	32.0	8.6
10	7311.00	33.2 AV	54.0	-20.8	1.78 V	186	24.6	8.6

REMARKS:

1. Emission Level(dBuV/m) = Raw Value(dBuV) + Correction Factor(dB/m)
2. Correction Factor(dB/m) = Antenna Factor(dB/m) + Cable Factor(dB) – Pre-Amplifier Factor(dB)
3. The other emission levels were very low against the limit.
4. Margin value = Emission Level – Limit value
5. " * ": Fundamental frequency.

CHANNEL	TX Channel 9	DETECTOR FUNCTION	Peak (PK)
FREQUENCY RANGE	1GHz ~ 25GHz		Average (AV)

ANTENNA POLARITY & TEST DISTANCE: HORIZONTAL AT 3 M

NO.	FREQ. (MHz)	EMISSION LEVEL (dBuV/m)	LIMIT (dBuV/m)	MARGIN (dB)	ANTENNA HEIGHT (m)	TABLE ANGLE (Degree)	RAW VALUE (dBuV)	CORRECTION FACTOR (dB/m)
1	*2452.00	105.3 PK			1.08 H	204	107.2	-1.9
2	*2452.00	96.6 AV			1.08 H	204	98.5	-1.9
3	2483.50	68.2 PK	74.0	-5.8	1.08 H	204	70.0	-1.8
4	2483.50	53.5 AV	54.0	-0.5	1.08 H	204	55.3	-1.8
5	4904.00	48.2 PK	74.0	-25.8	1.45 H	272	45.8	2.4
6	4904.00	44.1 AV	54.0	-9.9	1.45 H	272	41.7	2.4
7	7356.00	40.2 PK	74.0	-33.8	1.59 H	338	31.6	8.6
8	7356.00	31.4 AV	54.0	-22.6	1.59 H	338	22.8	8.6

ANTENNA POLARITY & TEST DISTANCE: VERTICAL AT 3 M

NO.	FREQ. (MHz)	EMISSION LEVEL (dBuV/m)	LIMIT (dBuV/m)	MARGIN (dB)	ANTENNA HEIGHT (m)	TABLE ANGLE (Degree)	RAW VALUE (dBuV)	CORRECTION FACTOR (dB/m)
1	*2452.00	106.8 PK			2.32 V	210	108.7	-1.9
2	*2452.00	97.7 AV			2.32 V	210	99.6	-1.9
3	2483.50	69.7 PK	74.0	-4.3	2.32 V	210	71.5	-1.8
4	2483.50	53.8 AV	54.0	-0.2	2.32 V	210	55.6	-1.8
5	4904.00	55.9 PK	74.0	-18.1	1.07 V	123	53.5	2.4
6	4904.00	45.7 AV	54.0	-8.3	1.07 V	123	43.3	2.4
7	7356.00	41.5 PK	74.0	-32.5	1.76 V	183	32.9	8.6
8	7356.00	34.1 AV	54.0	-19.9	1.76 V	183	25.5	8.6

REMARKS:

1. Emission Level(dBuV/m) = Raw Value(dBuV) + Correction Factor(dB/m)
2. Correction Factor(dB/m) = Antenna Factor(dB/m) + Cable Factor(dB) – Pre-Amplifier Factor(dB)
3. The other emission levels were very low against the limit.
4. Margin value = Emission Level – Limit value
5. " * ": Fundamental frequency.

Below 1GHz Data:

802.11g

CHANNEL	TX Channel 6	DETECTOR FUNCTION	Quasi-Peak (QP)
FREQUENCY RANGE	9kHz ~ 1GHz		

ANTENNA POLARITY & TEST DISTANCE: HORIZONTAL AT 3 M

NO.	FREQ. (MHz)	EMISSION LEVEL (dBuV/m)	LIMIT (dBuV/m)	MARGIN (dB)	ANTENNA HEIGHT (m)	TABLE ANGLE (Degree)	RAW VALUE (dBuV)	CORRECTION FACTOR (dB/m)
1	43.80	23.1 QP	40.0	-16.9	2.00 H	262	36.0	-12.9
2	155.59	22.4 QP	43.5	-21.1	2.00 H	62	35.6	-13.2
3	304.51	29.0 QP	46.0	-17.0	1.00 H	174	41.6	-12.6
4	739.51	31.9 QP	46.0	-14.1	1.00 H	25	35.1	-3.2
5	792.01	37.8 QP	46.0	-8.2	2.00 H	238	40.7	-2.9
6	913.52	34.7 QP	46.0	-11.3	1.50 H	0	35.5	-0.8

ANTENNA POLARITY & TEST DISTANCE: VERTICAL AT 3 M

NO.	FREQ. (MHz)	EMISSION LEVEL (dBuV/m)	LIMIT (dBuV/m)	MARGIN (dB)	ANTENNA HEIGHT (m)	TABLE ANGLE (Degree)	RAW VALUE (dBuV)	CORRECTION FACTOR (dB/m)
1	41.45	36.0 QP	40.0	-4.0	1.50 V	360	49.5	-13.5
2	101.93	26.2 QP	43.5	-17.3	1.00 V	56	43.5	-17.3
3	156.71	24.2 QP	43.5	-19.3	1.00 V	357	37.4	-13.2
4	304.51	29.8 QP	46.0	-16.2	1.00 V	10	42.4	-12.6
5	792.01	37.7 QP	46.0	-8.3	1.50 V	360	40.6	-2.9
6	913.52	32.0 QP	46.0	-14.0	1.00 V	17	32.8	-0.8

REMARKS:

1. Emission Level(dBuV/m) = Raw Value(dBuV) + Correction Factor(dB/m)
2. Correction Factor(dB/m) = Antenna Factor(dB/m) + Cable Factor(dB) – Pre-Amplifier Factor(dB)
3. The other emission levels were very low against the limit.
4. Margin value = Emission Level – Limit value

4.2 Conducted Emission Measurement

4.2.1 Limits of Conducted Emission Measurement

Frequency (MHz)	Conducted Limit (dBuV)	
	Quasi-peak	Average
0.15 - 0.5	66 - 56	56 - 46
0.50 - 5.0	56	46
5.0 - 30.0	60	50

Note: 1. The lower limit shall apply at the transition frequencies.

2. The limit decreases in line with the logarithm of the frequency in the range of 0.15 to 0.50MHz.

4.2.2 Test Instruments

DESCRIPTION & MANUFACTURER	MODEL NO.	SERIAL NO.	CALIBRATED DATE	CALIBRATED UNTIL
Test Receiver R&S	ESCS 30	847124/029	Oct. 24, 2016	Oct. 23, 2017
Line-Impedance Stabilization Network (for EUT) R&S	ESH3-Z5	848773/004	Oct. 26, 2016	Oct. 25, 2017
Line-Impedance Stabilization Network (for Peripheral) R&S	ENV216	100072	June 13, 2016	June 12, 2017
50 ohms Terminator	N/A	EMC-02	Sep. 29, 2016	Sep. 28, 2017
RF Cable	5D-FB	COCCAB-001	Sep. 30, 2016	Sep. 29, 2017
10 dB PAD Mini-Circuits	HAT-10+	CONATT-004	June 20, 2016	June 19, 2017
Software BVADT	BVADT_Cond_ V7.3.7.4	NA	NA	NA

Note:

1. The calibration interval of the above test instruments are 12 months and the calibrations are traceable to NML/ROC and NIST/USA.
2. The test was performed in Shielded Room No. 1.
3. Tested Date: Mar. 03 to 16, 2017

4.2.3 Test Procedures

- The EUT was placed 0.4 meters from the conducting wall of the shielded room with EUT being connected to the power mains through a line impedance stabilization network (LISN). Other support units were connected to the power mains through another LISN. The two LISNs provide 50 ohm/ 50uH of coupling impedance for the measuring instrument.
- Both lines of the power mains connected to the EUT were checked for maximum conducted interference.
- The frequency range from 150kHz to 30MHz was searched. Emission levels under (Limit - 20dB) was not recorded.

NOTE: The resolution bandwidth and video bandwidth of test receiver is 9kHz for quasi-peak detection (QP) and average detection (AV) at frequency 0.15MHz-30MHz.

4.2.4 Deviation from Test Standard

No deviation.

4.2.5 Test Setup

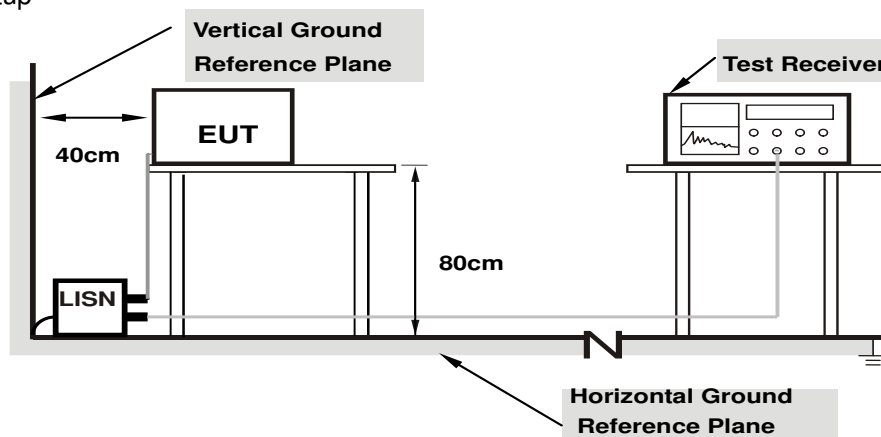

Note: 1.Support units were connected to second LISN.

For the actual test configuration, please refer to the attached file (Test Setup Photo).

4.2.6 EUT Operating Conditions

Same as 4.1.6.

4.2.7 Test Results (Mode 1)

Phase	Line (L)	Detector Function	Quasi-Peak (QP) / Average (AV)
-------	----------	-------------------	--------------------------------

No	Freq. [MHz]	Corr.	Reading Value		Emission Level		Limit		Margin	
		Factor (dB)	[dB (uV)]		[dB (uV)]		[dB (uV)]		(dB)	
		Q.P.	AV.	Q.P.	AV.	Q.P.	AV.	Q.P.	AV.	
1	0.15000	10.20	37.31	26.43	47.51	36.63	66.00	56.00	-18.49	-19.37
2	0.38828	10.24	33.53	32.08	43.77	42.32	58.10	48.10	-14.33	-5.78
3	12.00000	10.96	28.79	27.98	39.75	38.94	60.00	50.00	-20.25	-11.06
4	16.94141	11.46	25.59	20.43	37.05	31.89	60.00	50.00	-22.95	-18.11
5	24.00391	11.76	26.19	25.27	37.95	37.03	60.00	50.00	-22.05	-12.97

REMARKS:

1. Q.P. and AV. are abbreviations of quasi-peak and average individually.
2. The emission levels of other frequencies were very low against the limit.
3. Margin value = Emission level - Limit value
4. Correction factor = Insertion loss + Cable loss
5. Emission Level = Correction Factor + Reading Value.

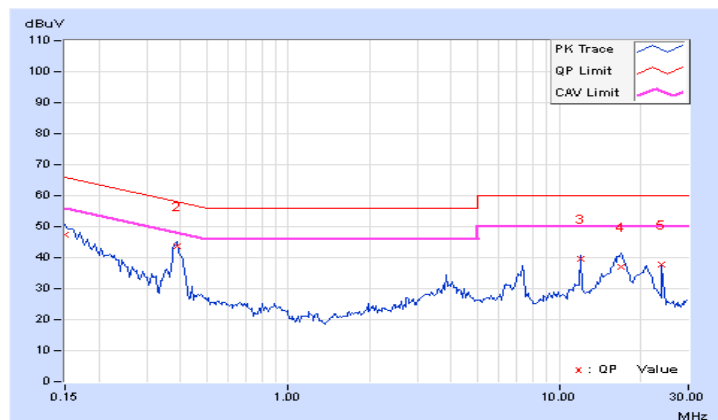

Phase	Neutral (N)	Detector Function	Quasi-Peak (QP) / Average (AV)
-------	-------------	-------------------	--------------------------------

No	Freq. [MHz]	Corr.	Reading Value		Emission Level		Limit		Margin	
		Factor	[dB (uV)]		[dB (uV)]		[dB (uV)]		(dB)	
		(dB)	Q.P.	AV.	Q.P.	AV.	Q.P.	AV.	Q.P.	AV.
1	0.15000	10.19	36.50	25.30	46.69	35.49	66.00	56.00	-19.31	-20.51
2	0.38438	10.23	28.42	26.18	38.65	36.41	58.18	48.18	-19.53	-11.77
3	12.00000	10.81	28.89	28.10	39.70	38.91	60.00	50.00	-20.30	-11.09
4	17.17578	11.22	24.40	19.55	35.62	30.77	60.00	50.00	-24.38	-19.23
5	24.00391	11.39	26.44	25.57	37.83	36.96	60.00	50.00	-22.17	-13.04

REMARKS:

1. Q.P. and AV. are abbreviations of quasi-peak and average individually.
2. The emission levels of other frequencies were very low against the limit.
3. Margin value = Emission level - Limit value
4. Correction factor = Insertion loss + Cable loss
5. Emission Level = Correction Factor + Reading Value.

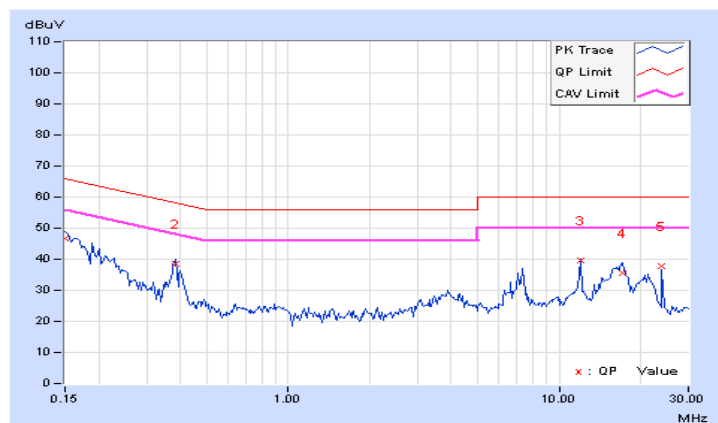

4.2.8 Test Results (Mode 2)

Phase	Line (L)	Detector Function	Quasi-Peak (QP) / Average (AV)
-------	----------	-------------------	--------------------------------

No	Freq. [MHz]	Corr. Factor	Reading Value [dB (uV)]		Emission Level [dB (uV)]		Limit [dB (uV)]		Margin (dB)	
		(dB)	Q.P.	AV.	Q.P.	AV.	Q.P.	AV.	Q.P.	AV.
	1	0.16928	10.19	35.78	27.07	45.97	37.26	65.00	55.00	-19.03
2	0.50547	10.23	30.42	27.80	40.65	38.03	56.00	46.00	-15.35	-7.97
3	4.52344	10.27	24.30	14.94	34.57	25.21	56.00	46.00	-21.43	-20.79
4	5.51172	10.32	24.96	16.47	35.28	26.79	60.00	50.00	-24.72	-23.21
5	15.25000	11.07	30.28	24.54	41.35	35.61	60.00	50.00	-18.65	-14.39
6	24.10156	11.42	31.90	25.83	43.32	37.25	60.00	50.00	-16.68	-12.75

REMARKS:

1. Q.P. and AV. are abbreviations of quasi-peak and average individually.
2. The emission levels of other frequencies were very low against the limit.
3. Margin value = Emission level - Limit value
4. Correction factor = Insertion loss + Cable loss
5. Emission Level = Correction Factor + Reading Value.

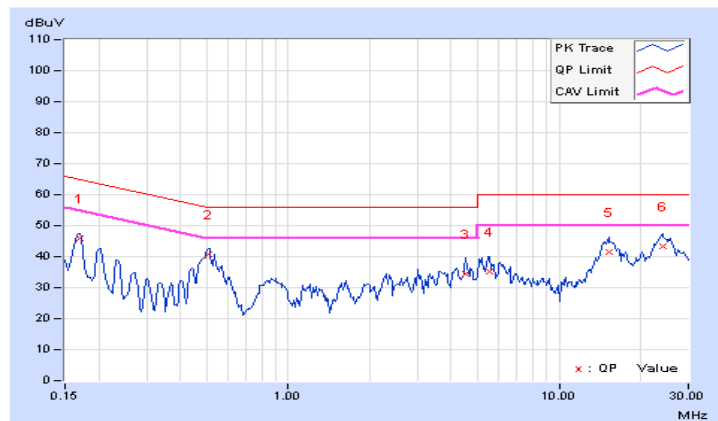

Phase	Neutral (N)	Detector Function	Quasi-Peak (QP) / Average (AV)
-------	-------------	-------------------	--------------------------------

No	Freq. [MHz]	Corr.	Reading Value		Emission Level		Limit		Margin	
		Factor	[dB (uV)]		[dB (uV)]		[dB (uV)]		(dB)	
		(dB)	Q.P.	AV.	Q.P.	AV.	Q.P.	AV.	Q.P.	AV.
1	0.16953	10.17	35.66	26.28	45.83	36.45	64.98	54.98	-19.15	-18.53
2	0.50547	10.21	30.38	27.31	40.59	37.52	56.00	46.00	-15.41	-8.48
3	5.54297	10.24	25.89	14.19	36.13	24.43	60.00	50.00	-23.87	-25.57
4	15.79688	10.92	32.55	27.86	43.47	38.78	60.00	50.00	-16.53	-11.22
5	18.16406	11.02	31.19	25.54	42.21	36.56	60.00	50.00	-17.79	-13.44
6	24.21094	11.08	31.77	25.96	42.85	37.04	60.00	50.00	-17.15	-12.96

REMARKS:

1. Q.P. and AV. are abbreviations of quasi-peak and average individually.
2. The emission levels of other frequencies were very low against the limit.
3. Margin value = Emission level - Limit value
4. Correction factor = Insertion loss + Cable loss
5. Emission Level = Correction Factor + Reading Value.

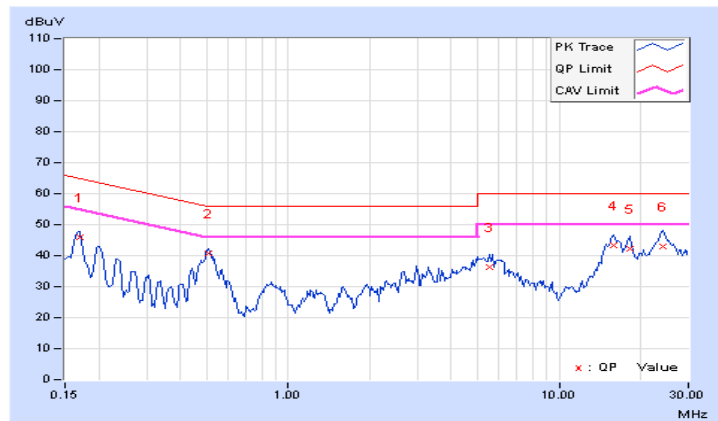

4.3 6dB Bandwidth Measurement

4.3.1 Limits of 6dB Bandwidth Measurement

The minimum of 6dB Bandwidth Measurement is 0.5 MHz.

4.3.2 Test Setup

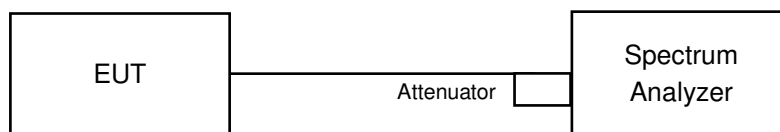

4.3.3 Test Instruments

Refer to section 4.1.2 to get information of above instrument.

4.3.4 Test Procedure

- a. Set resolution bandwidth (RBW) = 100kHz
- b. Set the video bandwidth (VBW) $\geq 3 \times$ RBW, Detector = Peak.
- c. Trace mode = max hold.
- d. Sweep = auto couple.
- e. Measure the maximum width of the emission that is constrained by the frequencies associated with the two amplitude points (upper and lower) that are attenuated by 6 dB relative to the maximum level measured in the fundamental emission

4.3.5 Deviation from Test Standard

No deviation.

4.3.6 EUT Operating Conditions

The software provided by client to enable the EUT under transmission condition continuously at lowest, middle and highest channel frequencies individually.

4.3.7 Test Result

802.11b

Channel	Frequency (MHz)	6dB Bandwidth (MHz)		Minimum Limit (MHz)	Pass / Fail
		Chain 0	Chain 1		
1	2412	9.02	8.10	0.5	PASS
6	2437	8.09	8.56	0.5	PASS
11	2462	8.56	8.58	0.5	PASS

802.11g

Channel	Frequency (MHz)	6dB Bandwidth (MHz)		Minimum Limit (MHz)	Pass / Fail
		Chain 0	Chain 1		
1	2412	16.37	16.43	0.5	PASS
6	2437	16.36	16.34	0.5	PASS
11	2462	16.35	16.34	0.5	PASS

802.11n (HT20)

Channel	Frequency (MHz)	6dB Bandwidth (MHz)		Minimum Limit (MHz)	Pass / Fail
		Chain 0	Chain 1		
1	2412	17.59	16.95	0.5	Pass
6	2437	16.96	17.61	0.5	Pass
11	2462	17.60	17.59	0.5	Pass

802.11n (HT40)

Channel	Frequency (MHz)	6dB Bandwidth (MHz)		Minimum Limit (MHz)	Pass / Fail
		Chain 0	Chain 1		
3	2422	36.10	36.08	0.5	Pass
6	2437	36.47	36.01	0.5	Pass
9	2452	36.15	36.40	0.5	Pass

Spectrum Plot of Worst Value

802.11b / Chain 0 : CH6

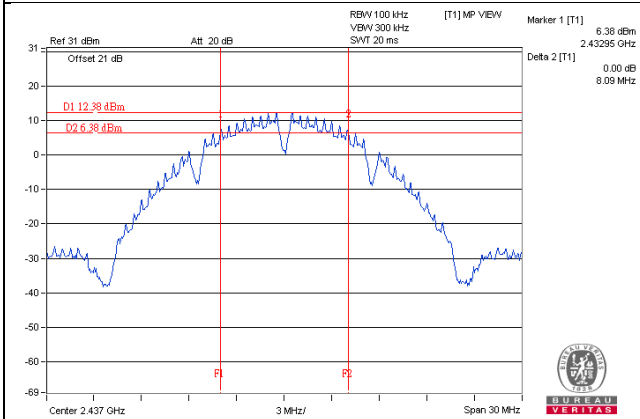

802.11g / Chain 1 : CH6

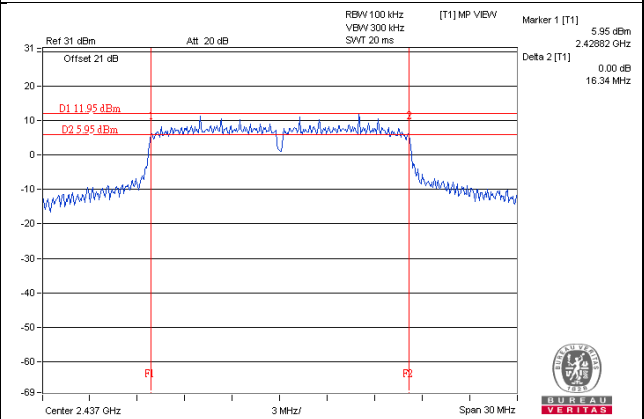

802.11n (HT20) / Chain 1 : CH1

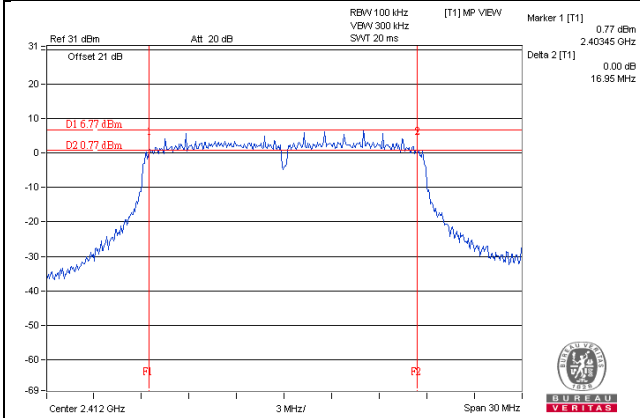

802.11n (HT40) / Chain 1 : CH6

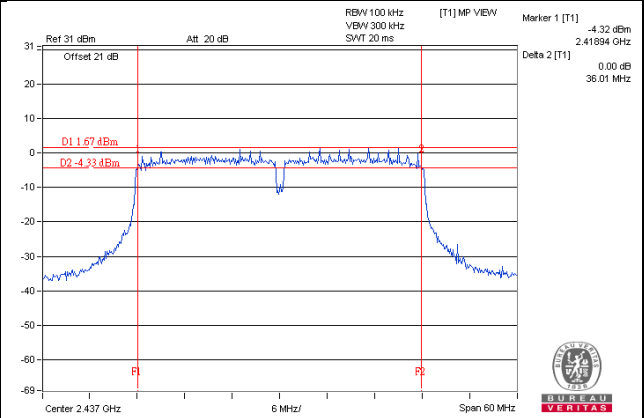

4.4 Conducted Output Power Measurement

4.4.1 Limits of Conducted Output Power Measurement

For systems using digital modulation in the 2400–2483.5 MHz bands: 1 Watt (30dBm)

Per KDB 662911 D01 Multiple Transmitter Output Method of conducted output power measurement on IEEE 802.11 devices,

Array Gain = 0 dB (i.e., no array gain) for $N_{ANT} \leq 4$;

Array Gain = 0 dB (i.e., no array gain) for channel widths ≥ 40 MHz for any N_{ANT} ;

Array Gain = $5 \log(N_{ANT}/N_{SS})$ dB or 3 dB, whichever is less for 20-MHz channel widths with $N_{ANT} \geq 5$.

For power measurements on all other devices: Array Gain = $10 \log(N_{ANT}/N_{SS})$ dB.

4.4.2 Test Setup

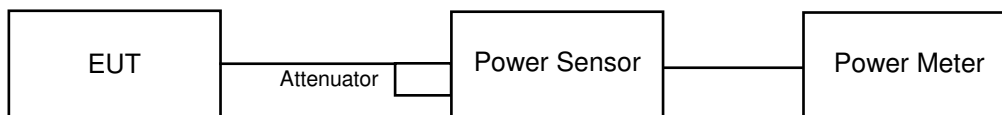

4.4.3 Test Instruments

Refer to section 4.1.2 to get information of above instrument.

4.4.4 Test Procedures

A peak / average power sensor was used on the output port of the EUT. A power meter was used to read the response of the peak / average power sensor. Record the power level.

4.4.5 Deviation from Test Standard

No deviation.

4.4.6 EUT Operating Conditions

Same as Item 4.3.6.

4.4.7 Test Results

FOR PEAK POWER
802.11b

Chan.	Freq. (MHz)	Peak Power (dBm)		Total Power (mW)	Total Power (dBm)	Limit (dBm)	Pass / Fail
		Chain 0	Chain 1				
1	2412	21.72	21.14	278.611	24.45	30	Pass
6	2437	22.42	21.46	314.541	24.98	30	Pass
11	2462	21.62	20.47	256.64	24.09	30	Pass

802.11g

Chan.	Freq. (MHz)	Peak Power (dBm)		Total Power (mW)	Total Power (dBm)	Limit (dBm)	Pass / Fail
		Chain 0	Chain 1				
1	2412	23.96	23.36	465.656	26.68	30	Pass
6	2437	26.25	25.70	793.232	28.99	30	Pass
11	2462	23.75	22.57	417.854	26.21	30	Pass

802.11n (HT20)

Chan.	Freq. (MHz)	Peak Power (dBm)		Total Power (mW)	Total Power (dBm)	Limit (dBm)	Pass / Fail
		Chain 0	Chain 1				
1	2412	24.20	23.46	484.847	26.86	30	Pass
6	2437	26.30	25.37	770.93	28.87	30	Pass
11	2462	23.60	22.09	390.895	25.92	30	Pass

802.11n (HT40)

Chan.	Freq. (MHz)	Peak Power (dBm)		Total Power (mW)	Total Power (dBm)	Limit (dBm)	Pass / Fail
		Chain 0	Chain 1				
3	2422	21.35	20.58	250.746	23.99	30	Pass
6	2437	23.31	22.45	390.081	25.91	30	Pass
9	2452	20.19	19.35	190.571	22.80	30	Pass

FOR AVERAGE POWER
802.11b

Chan.	Frequency (MHz)	Avg. Power (dBm)		Total Power (mW)	Total Power (dBm)
		Chain 0	Chain 1		
1	2412	19.40	18.79	162.779	22.12
6	2437	20.08	19.11	183.329	22.63
11	2462	19.22	18.10	148.125	21.71

802.11g

Chan.	Frequency (MHz)	Avg. Power (dBm)		Total Power (mW)	Total Power (dBm)
		Chain 0	Chain 1		
1	2412	17.67	17.04	109.061	20.38
6	2437	22.48	21.92	332.608	25.22
11	2462	17.52	16.37	99.845	19.99

802.11n (HT20)

Chan.	Frequency (MHz)	Avg. Power (dBm)		Total Power (mW)	Total Power (dBm)
		Chain 0	Chain 1		
1	2412	18.05	17.34	118.026	20.72
6	2437	22.15	21.33	299.89	24.77
11	2462	17.33	16.15	95.285	19.79

802.11n (HT40)

Chan.	Frequency (MHz)	Avg. Power (dBm)		Total Power (mW)	Total Power (dBm)
		Chain 0	Chain 1		
3	2422	14.67	13.85	53.575	17.29
6	2437	16.73	15.77	84.855	19.29
9	2452	13.77	12.88	43.232	16.36

4.5 Power Spectral Density Measurement

4.5.1 Limits of Power Spectral Density Measurement

The Maximum of Power Spectral Density Measurement is 8dBm.

4.5.2 Test Setup

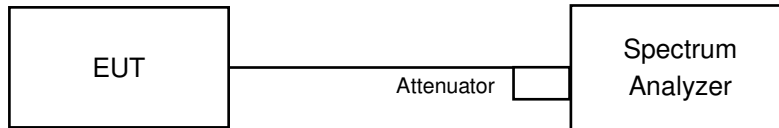

4.5.3 Test Instruments

Refer to section 4.1.2 to get information of above instrument.

4.5.4 Test Procedure

- a. Set analyzer center frequency to DTS channel center frequency.
- b. Set the span to 1.5 times the DTS bandwidth.
- c. Set the RBW to: $3 \text{ kHz} \leq \text{RBW} \leq 100 \text{ kHz}$.
- d. Set the VBW $\geq 3 \times \text{RBW}$.
- e. Detector = peak.
- f. Sweep time = auto couple.
- g. Trace mode = max hold.
- h. Allow trace to fully stabilize.
- i. Use the peak marker function to determine the maximum amplitude level within the RBW.

4.5.5 Deviation from Test Standard

No deviation.

4.5.6 EUT Operating Condition

Same as Item 4.3.6

4.5.7 Test Results

802.11b

TX chain	Channel	Freq. (MHz)	PSD (dBm/3kHz)	10 log (N=2) dB	Total PSD (dBm/3kHz)	Limit (dBm/3kHz)	Pass /Fail
0	1	2412	-3.38	3.01	-0.37	8.00	Pass
	6	2437	-2.80	3.01	0.21	8.00	Pass
	11	2462	-3.79	3.01	-0.78	8.00	Pass
1	1	2412	-4.84	3.01	-1.83	8.00	Pass
	6	2437	-3.78	3.01	-0.77	8.00	Pass
	11	2462	-3.47	3.01	-0.46	8.00	Pass

Note: Directional gain = $10 \log[(10^{G1/20} + 10^{G2/20})^2 / 2] = 5.33\text{dBi} < 6\text{dBi}$, so the power density limit shall not be reduced.

802.11g

TX chain	Channel	Freq. (MHz)	PSD (dBm/3kHz)	10 log (N=2) dB	Total PSD (dBm/3kHz)	Limit (dBm/3kHz)	Pass /Fail
0	1	2412	-7.25	3.01	-4.24	8.00	Pass
	6	2437	-3.31	3.01	-0.30	8.00	Pass
	11	2462	-7.00	3.01	-3.99	8.00	Pass
1	1	2412	-8.08	3.01	-5.07	8.00	Pass
	6	2437	-3.63	3.01	-0.62	8.00	Pass
	11	2462	-8.90	3.01	-5.89	8.00	Pass

Note: Directional gain = $10 \log[(10^{G1/20} + 10^{G2/20})^2 / 2] = 5.33\text{dBi} < 6\text{dBi}$, so the power density limit shall not be reduced.

802.11n (HT20)

TX chain	Channel	Freq. (MHz)	PSD (dBm/3kHz)	10 log (N=2) dB	Total PSD (dBm/3kHz)	Limit (dBm/3kHz)	Pass /Fail
0	1	2412	-7.53	3.01	-4.52	8.00	Pass
	6	2437	-2.90	3.01	0.11	8.00	Pass
	11	2462	-8.28	3.01	-5.27	8.00	Pass
1	1	2412	-8.69	3.01	-5.68	8.00	Pass
	6	2437	-4.48	3.01	-1.47	8.00	Pass
	11	2462	-8.52	3.01	-5.51	8.00	Pass

Note: Directional gain = $10 \log[(10^{G1/20} + 10^{G2/20})^2 / 2] = 5.33\text{dBi} < 6\text{dBi}$, so the power density limit shall not be reduced.

802.11n (HT40)

TX chain	Channel	Freq. (MHz)	PSD (dBm/3kHz)	10 log (N=2) dB	Total PSD (dBm/3kHz)	Limit (dBm/3kHz)	Pass /Fail
0	3	2422	-13.84	3.01	-10.83	8.00	Pass
	6	2437	-12.12	3.01	-9.11	8.00	Pass
	9	2452	-15.09	3.01	-12.08	8.00	Pass
1	3	2422	-13.52	3.01	-10.51	8.00	Pass
	6	2437	-13.51	3.01	-10.50	8.00	Pass
	9	2452	-16.43	3.01	-13.42	8.00	Pass

Note: Directional gain = $10 \log[(10^{G1/20} + 10^{G2/20})^2 / 2]$ = 5.33dBi < 6dBi , so the power density limit shall not be reduced.

Spectrum Plot of Worst Value

802.11b / Chain 0 : CH6

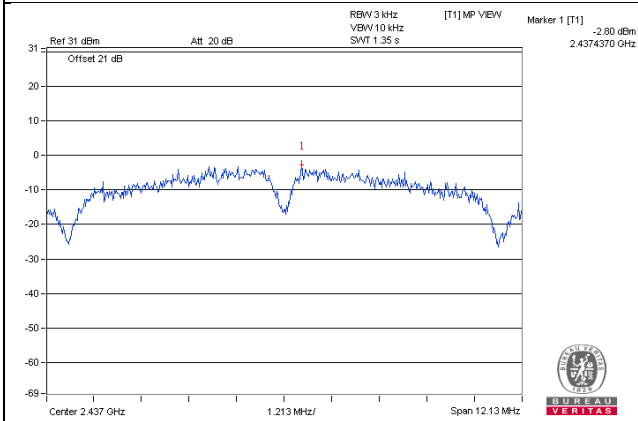

802.11g / Chain 0 : CH6

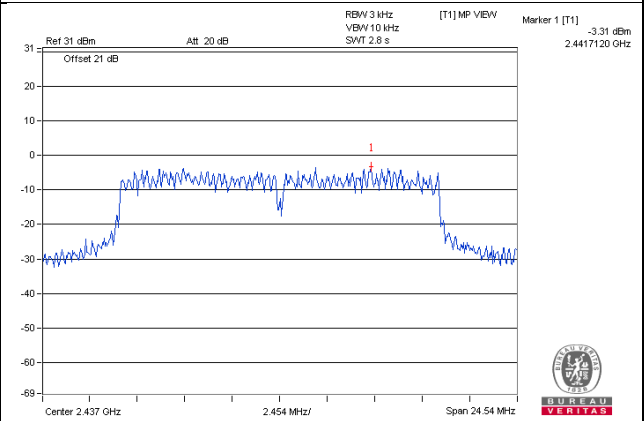

802.11n (HT20) / Chain 0 : CH6

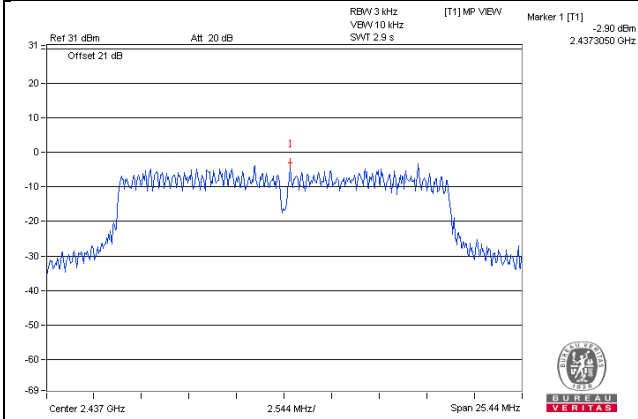

802.11n (HT40) / Chain 0 : CH6

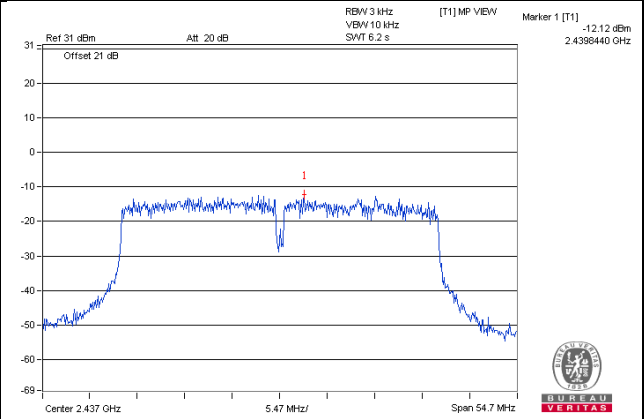

4.6 Conducted Out of Band Emission Measurement

4.6.1 Limits of Conducted Out of Band Emission Measurement

Below 20dBc of the highest emission level of operating band (in 100kHz Resolution Bandwidth).

4.6.2 Test Setup

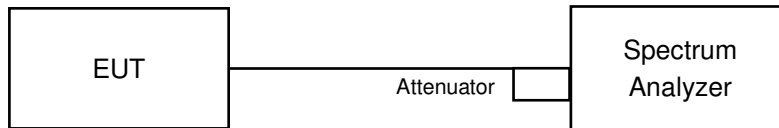

4.6.3 Test Instruments

Refer to section 4.1.2 to get information of above instrument.

4.6.4 Test Procedure

MEASUREMENT PROCEDURE REF

1. Set the RBW = 100 kHz.
2. Set the VBW \geq 300 kHz.
3. Detector = peak.
4. Sweep time = auto couple.
5. Trace mode = max hold.
6. Allow trace to fully stabilize.
7. Use the peak marker function to determine the maximum power level in any 100 kHz band segment within the fundamental EBW.

MEASUREMENT PROCEDURE OOB

1. Set RBW = 100 kHz.
2. Set VBW \geq 300 kHz.
3. Detector = peak.
4. Sweep = auto couple.
5. Trace Mode = max hold.
6. Allow trace to fully stabilize.
7. Use the peak marker function to determine the maximum amplitude level.

4.6.5 Deviation from Test Standard

No deviation.

4.6.6 EUT Operating Condition

Same as Item 4.3.6

4.6.7 Test Results

The spectrum plots are attached on the following pages. D1 line indicates the highest level, and D2 line indicates the 20dBc offset below D1. It shows compliance with the requirement.

802.11b - CHAIN 0

CH 1

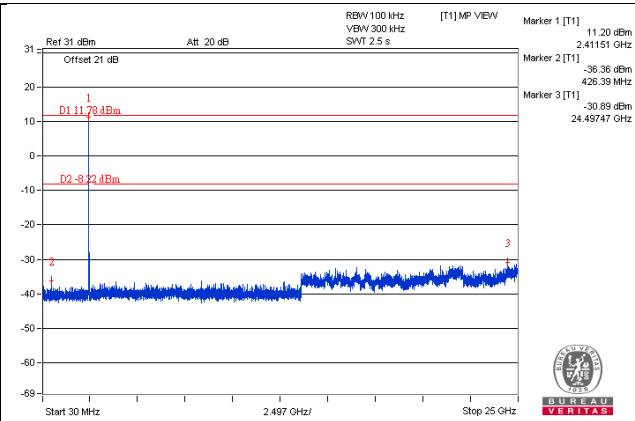
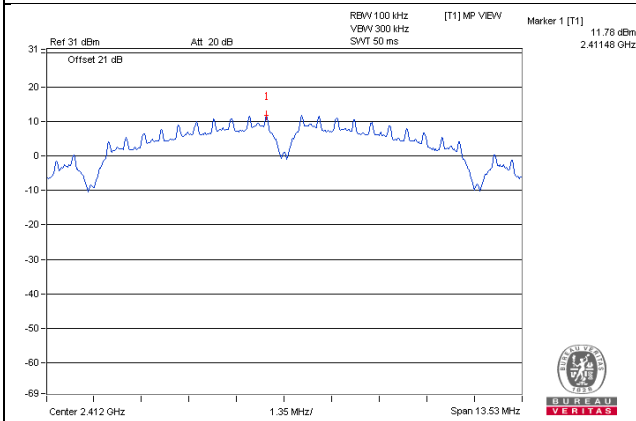

CH 6

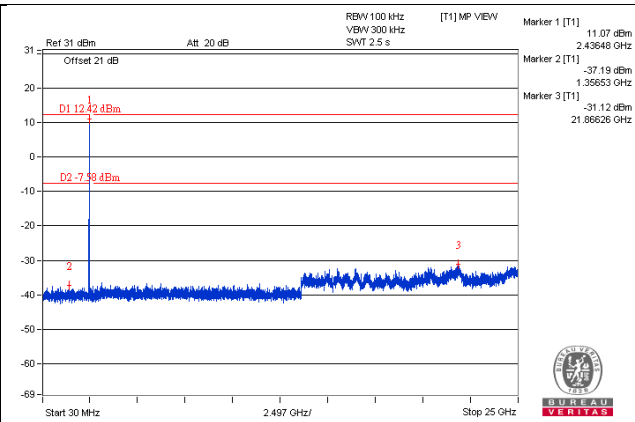
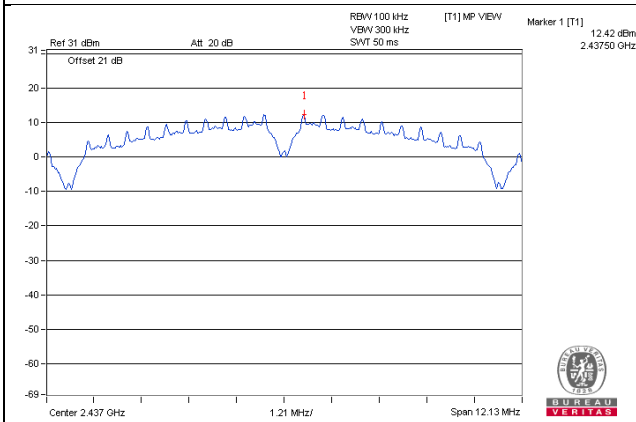

CH 11

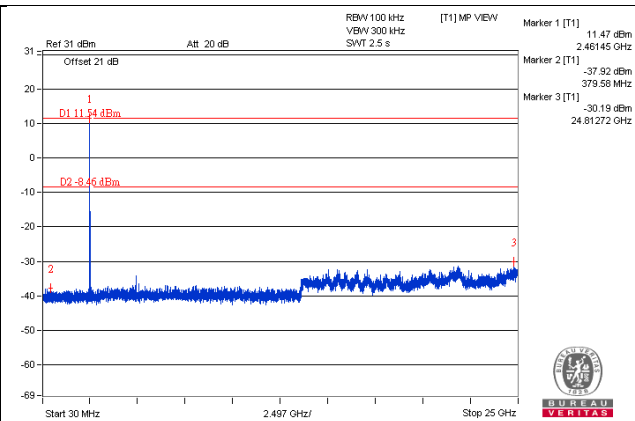
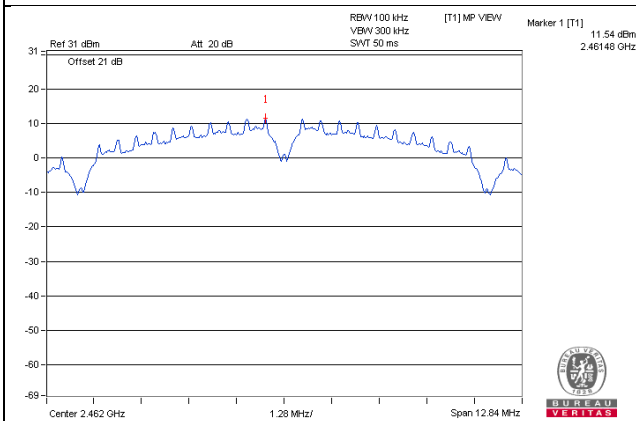

CH 1 Band edge

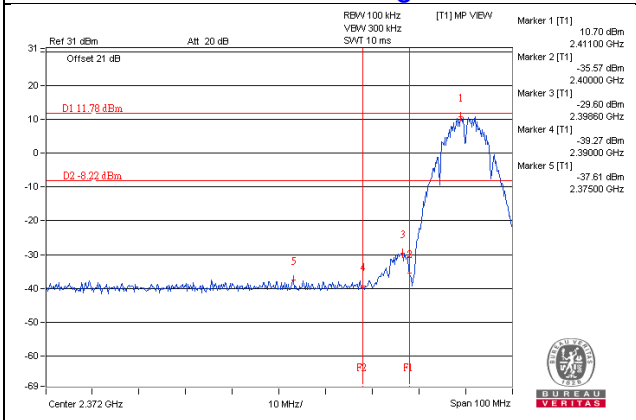

CH 11 Band edge

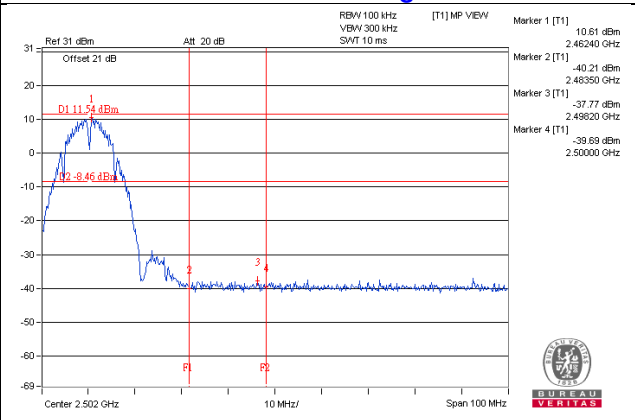

CHAIN 1

CH 1

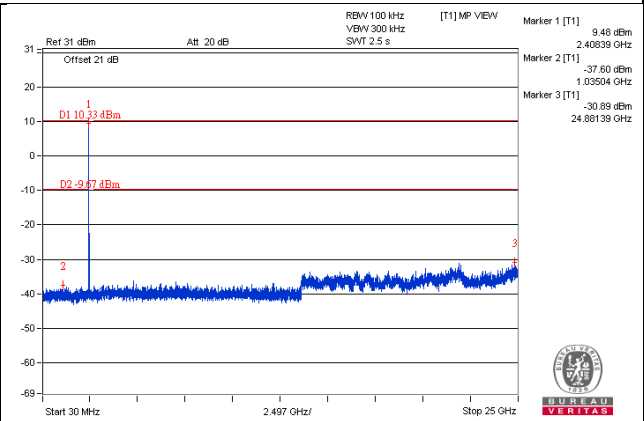
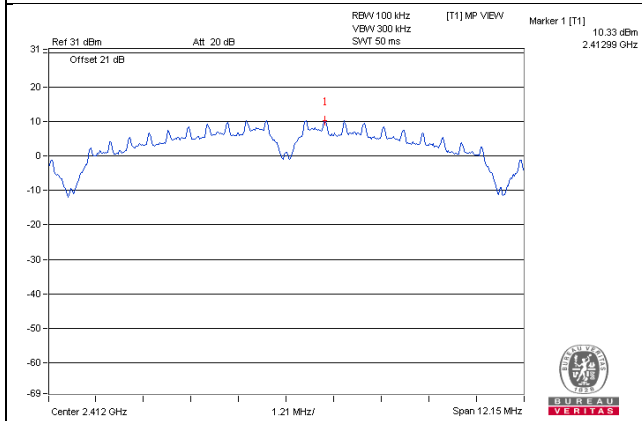

CH 6

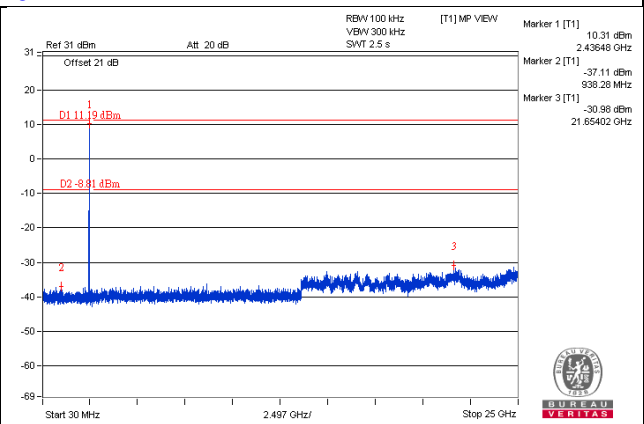
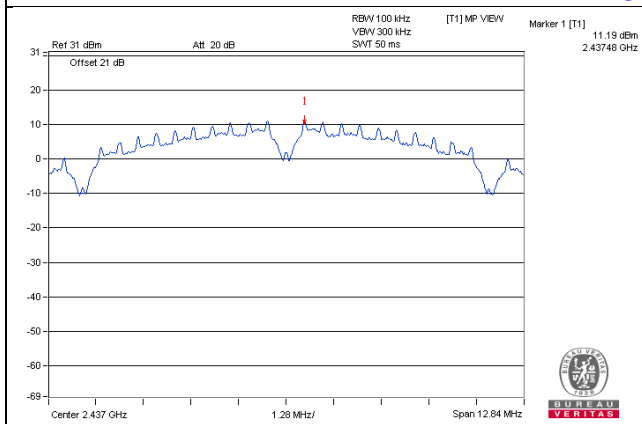

CH 11

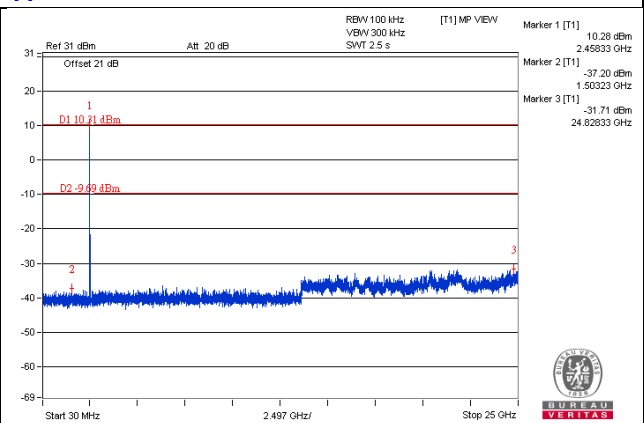
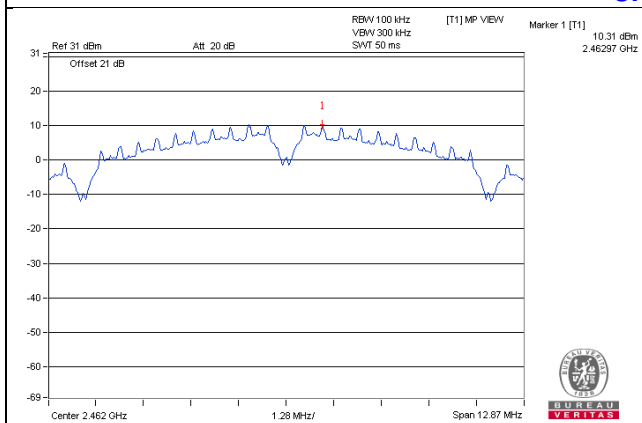

CH 1 Band edge

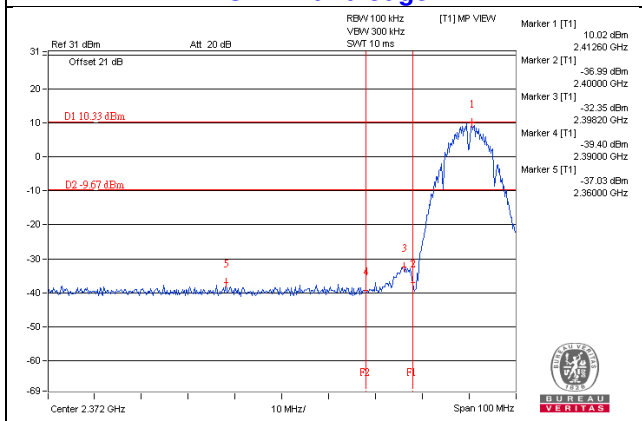

CH 11 Band edge

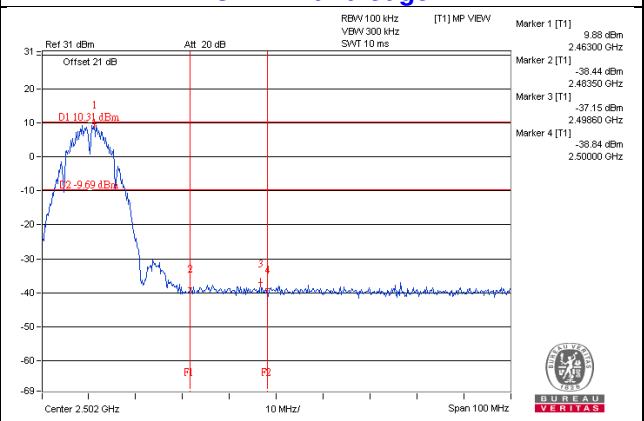

802.11g - CHAIN 0

CH 1

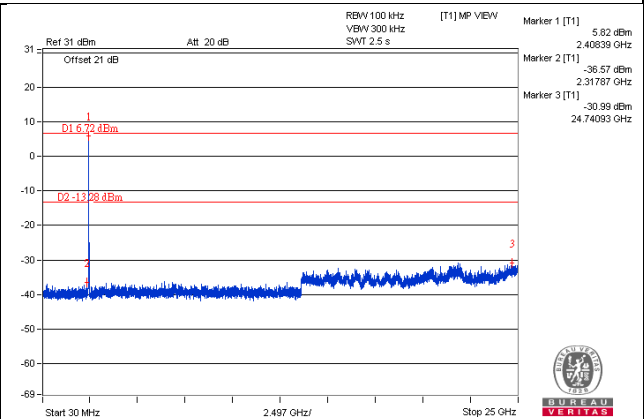
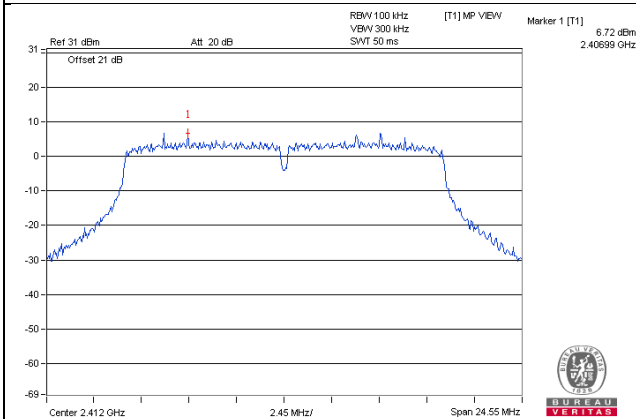

CH 6

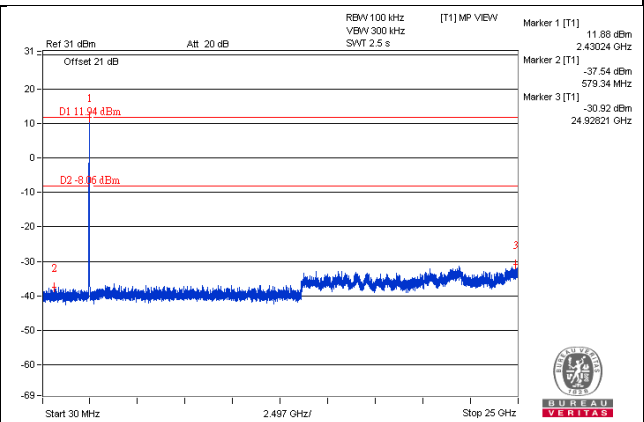
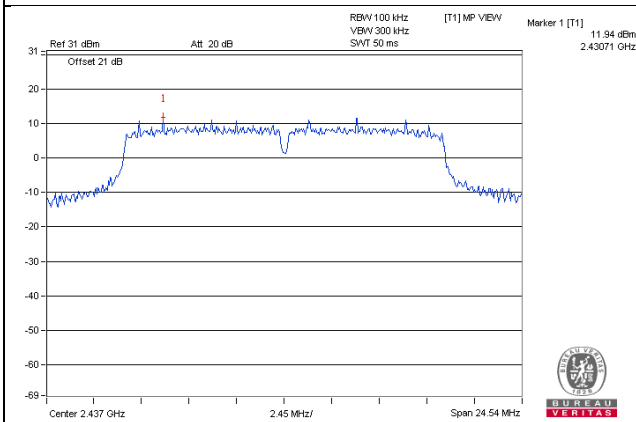

CH 11

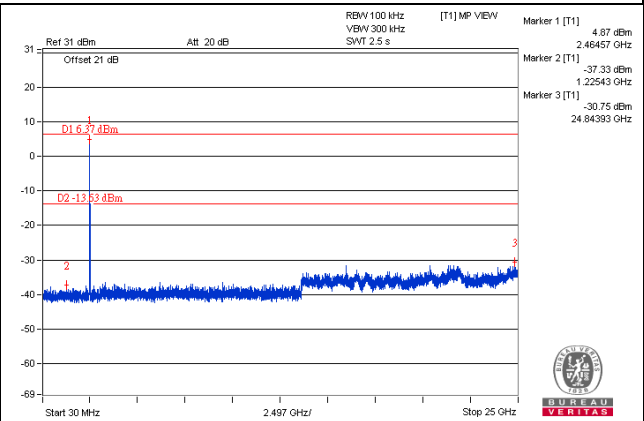
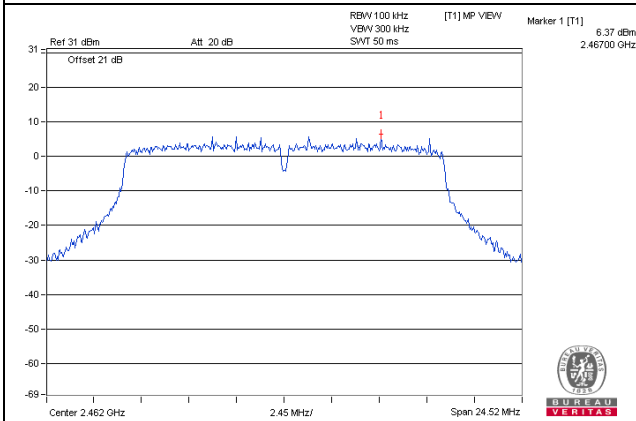

CH 1 Band edge

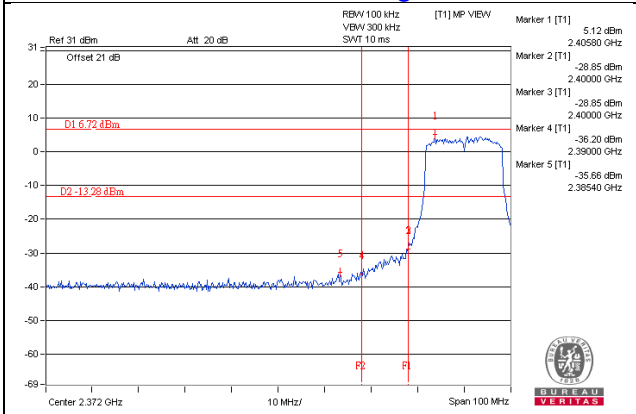

CH 11 Band edge

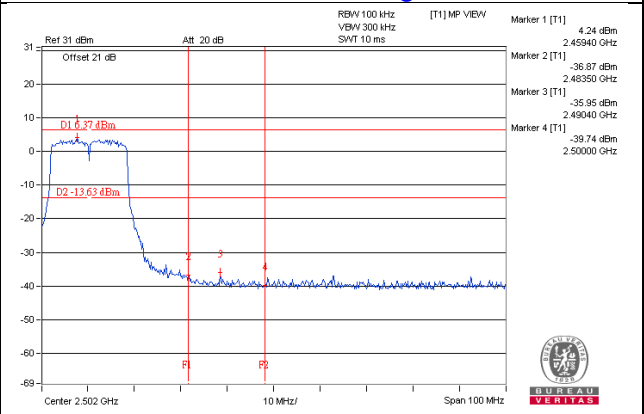

CHAIN 1

CH 1

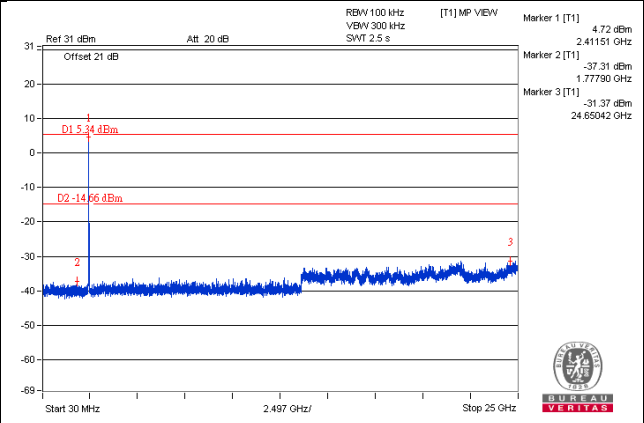
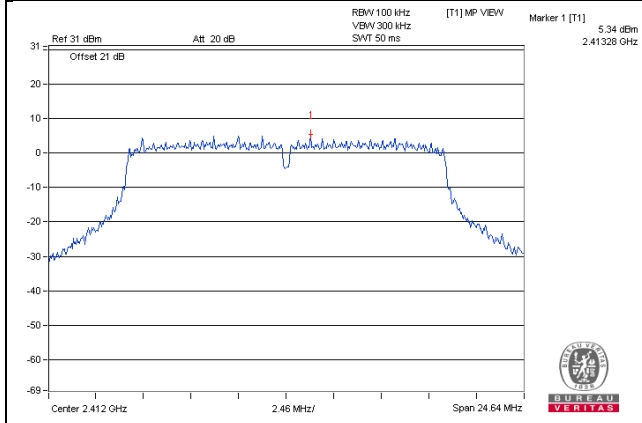

CH 6

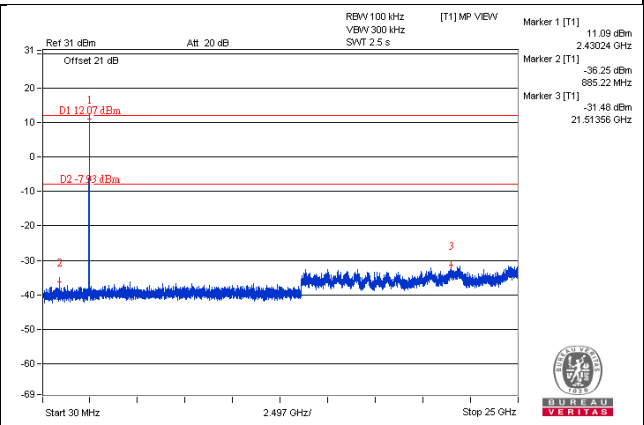
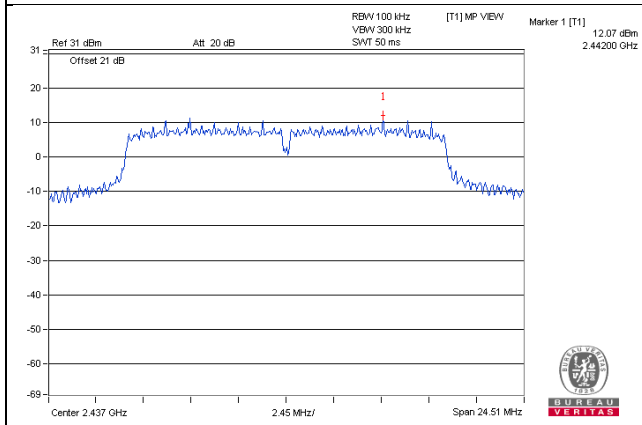

CH 11

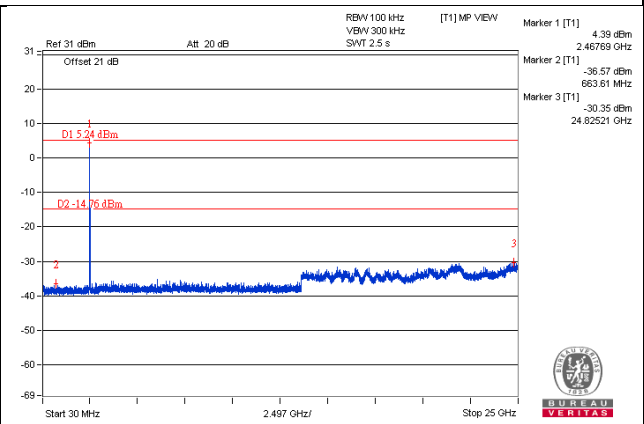
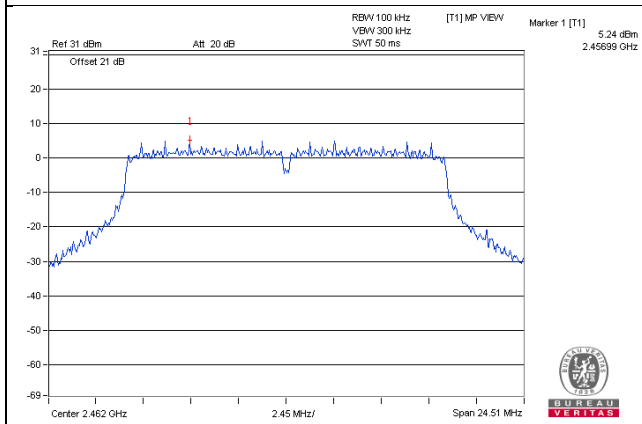

CH 1 Band edge

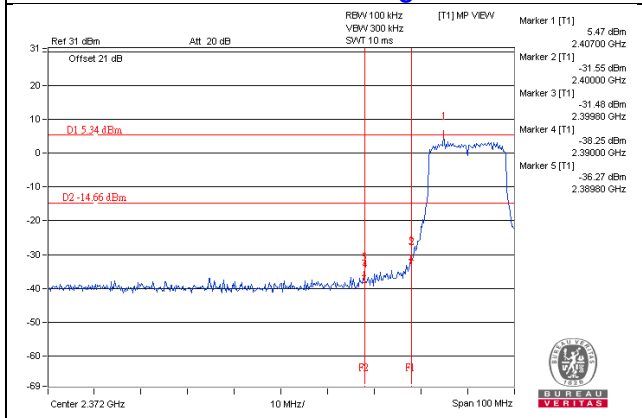

CH 11 Band edge

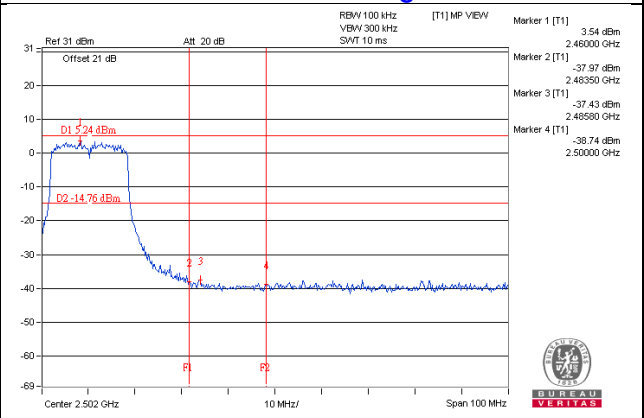

802.11n (HT20) - CHAIN 0

CH 1

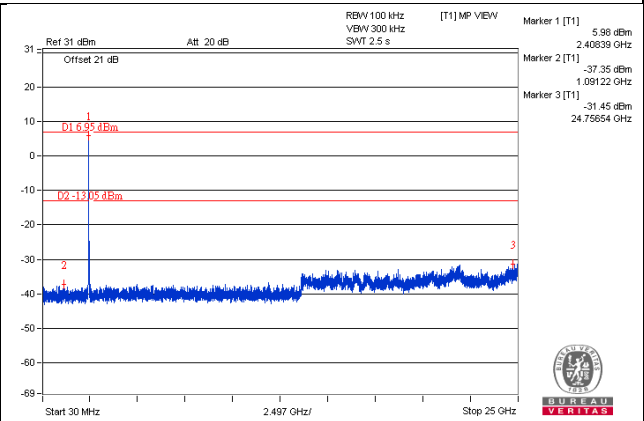
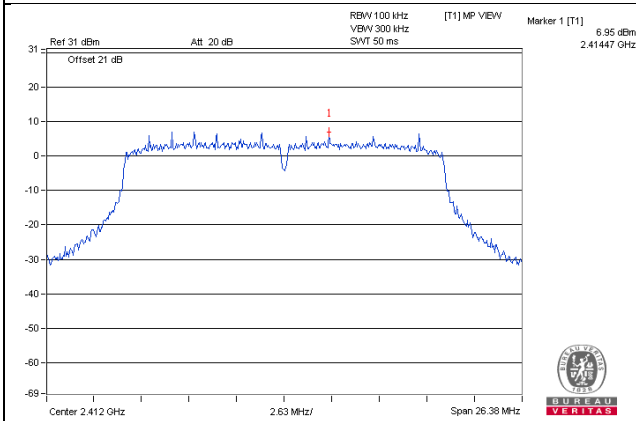

CH 6

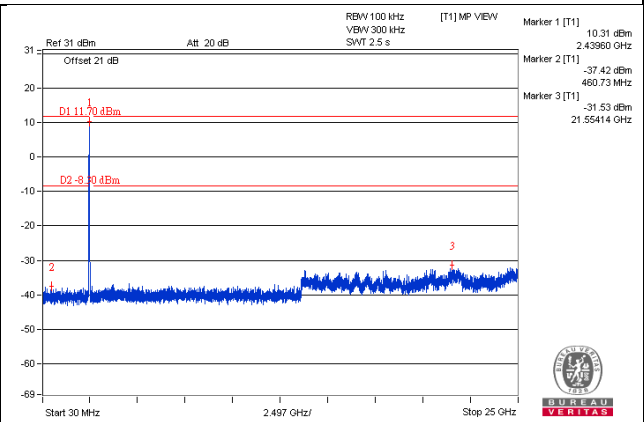
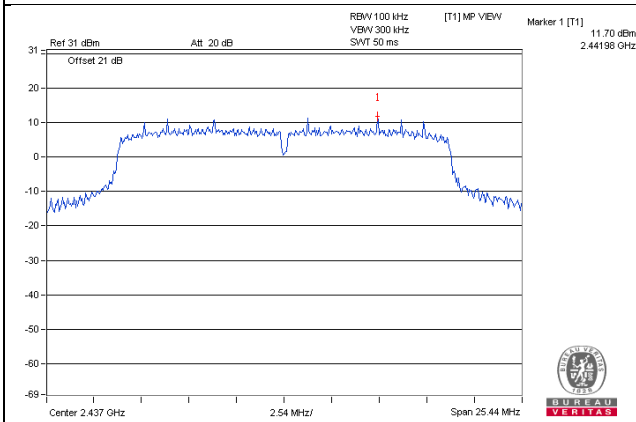

CH 11

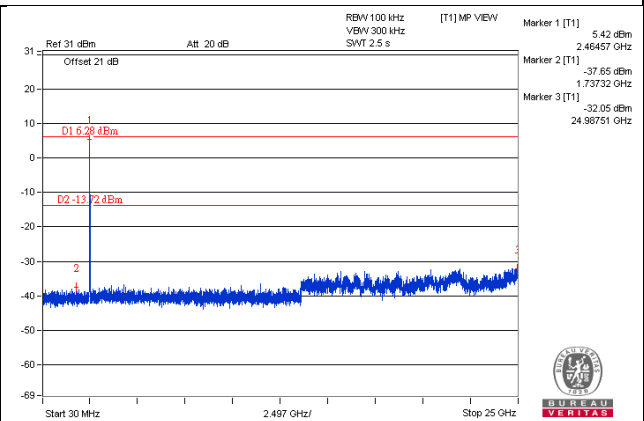
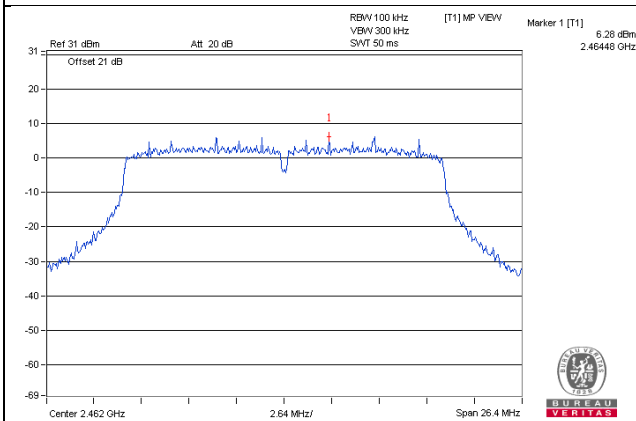

CH 1 Band edge

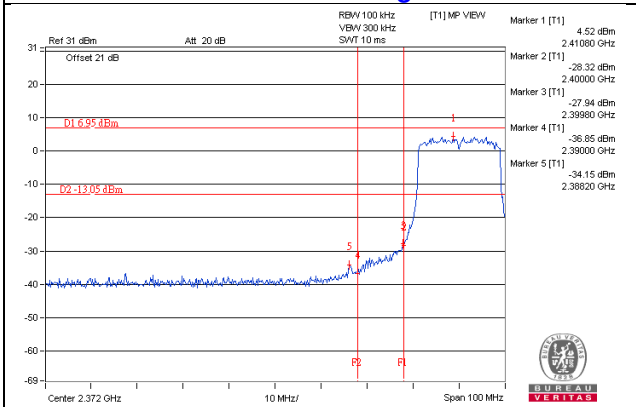

CH 11 Band edge

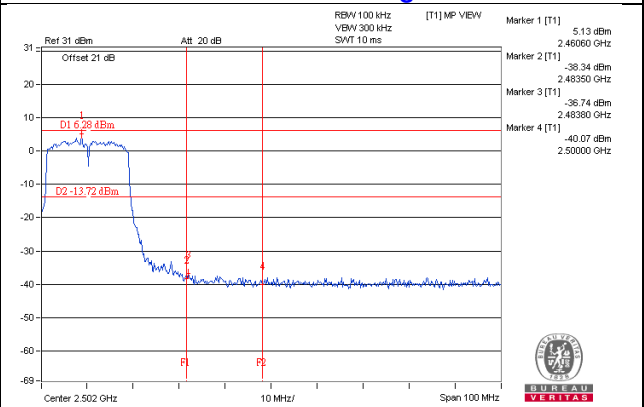

CHAIN 1

CH 1

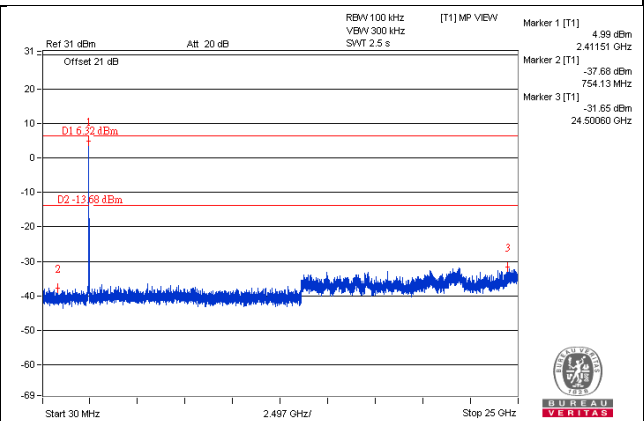
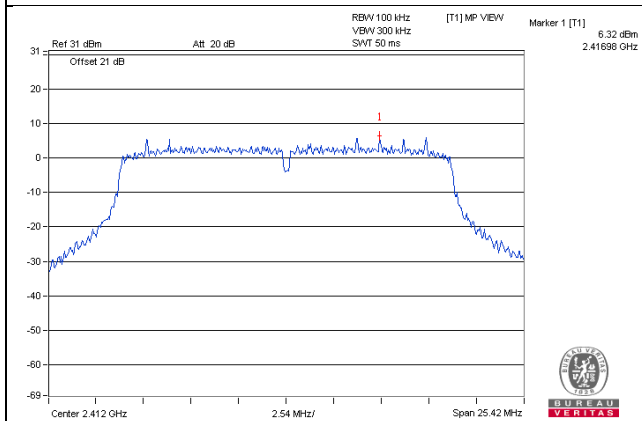

CH 6

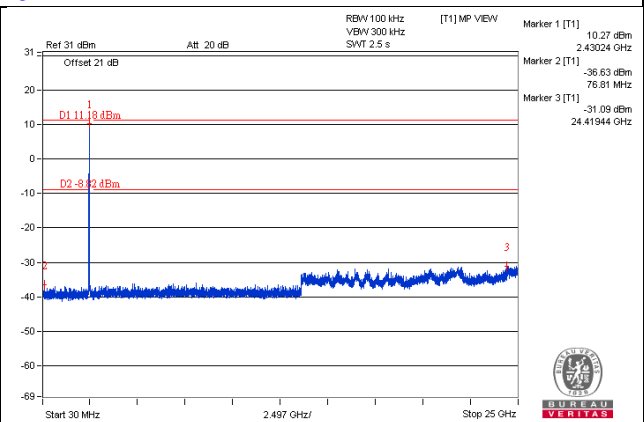
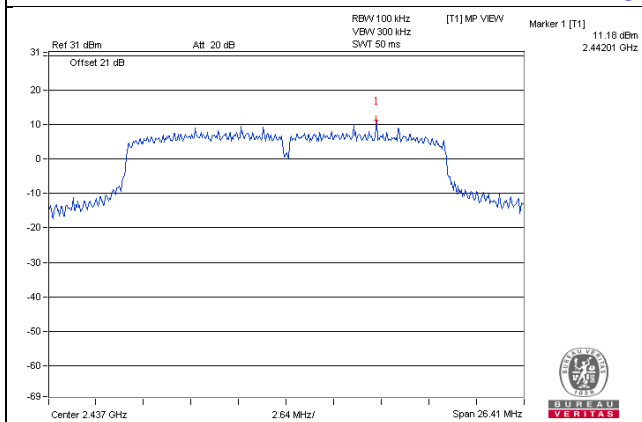

CH 11

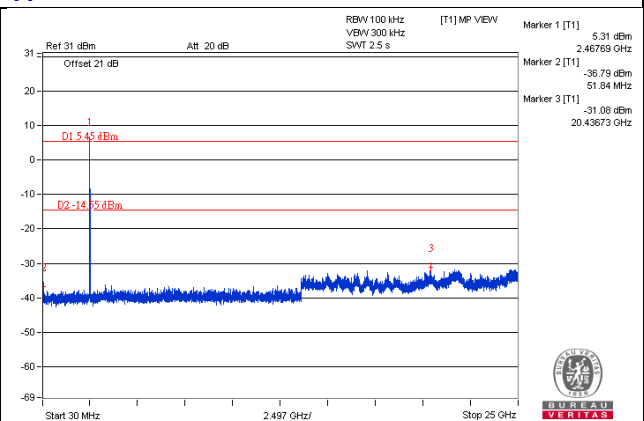
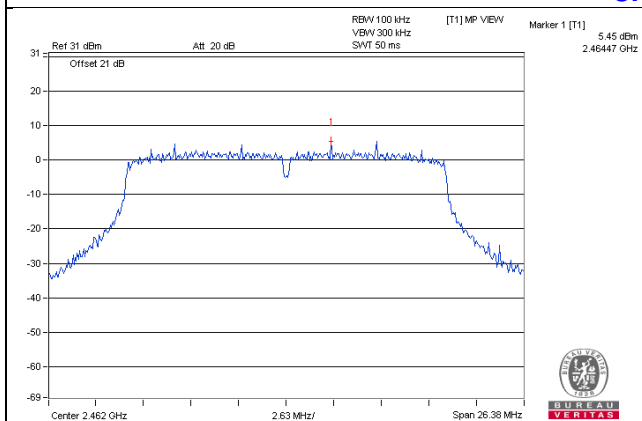

CH 1 Band edge

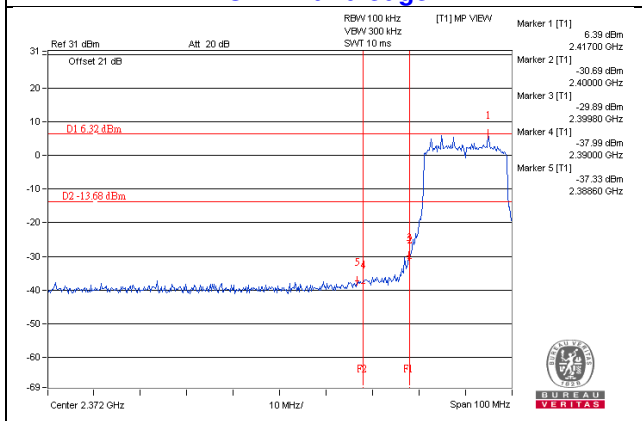

CH 11 Band edge

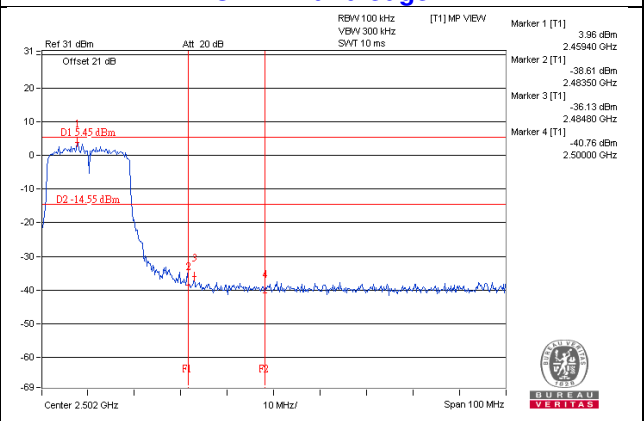

802.11n (HT40) - Chain 0

CH 3

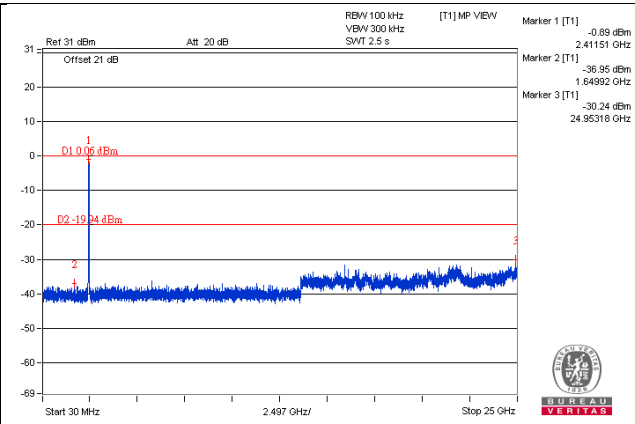
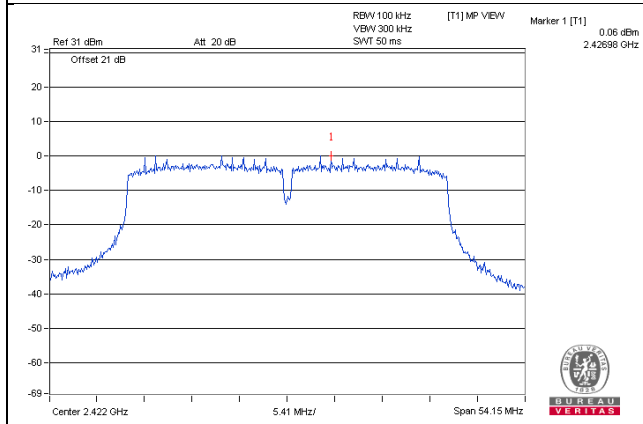

CH 6

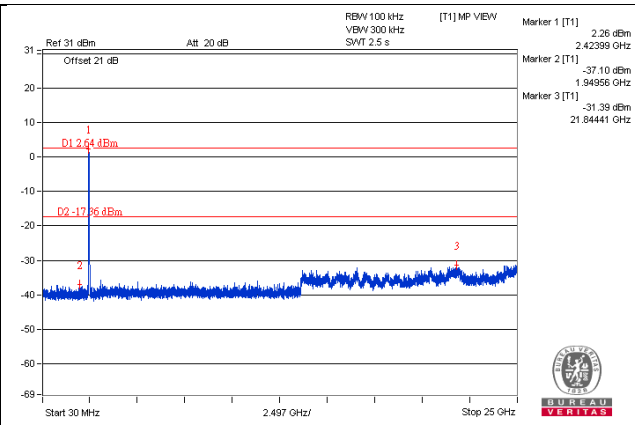
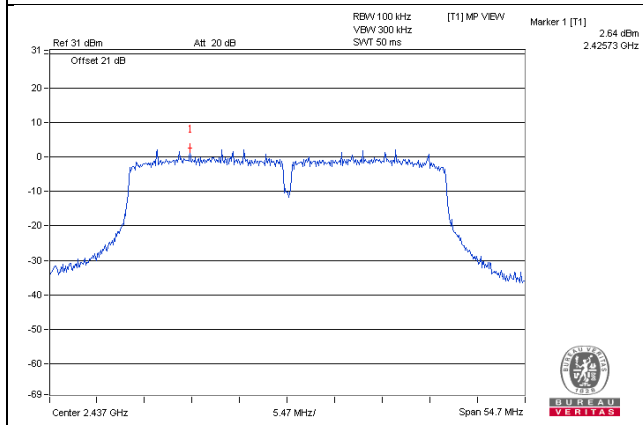

CH 9

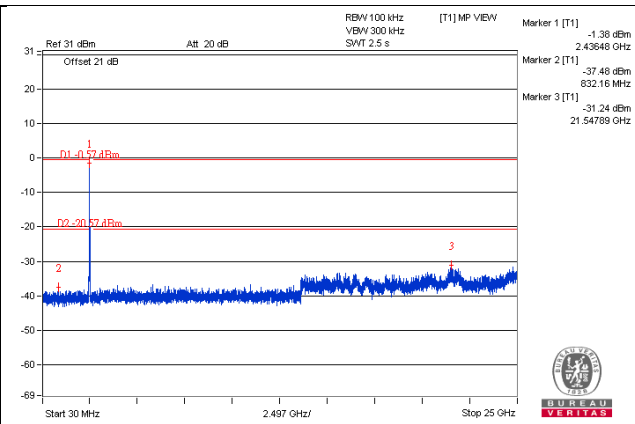
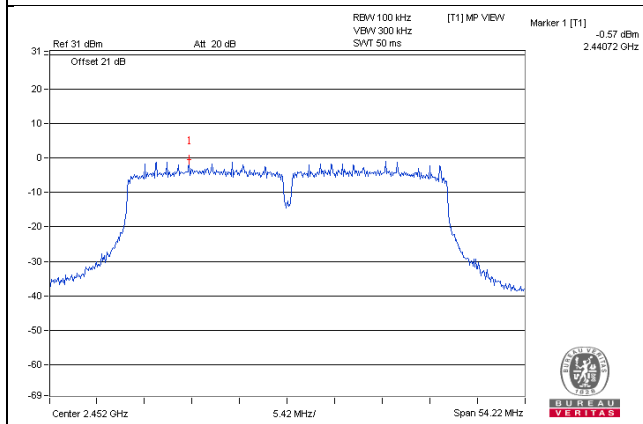

CH 3 Band edge

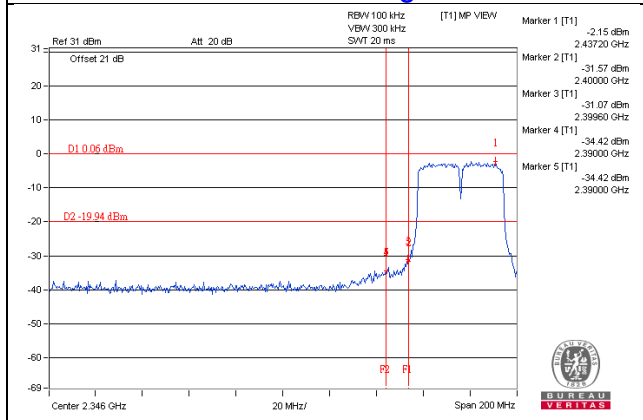

CH 9 Band edge

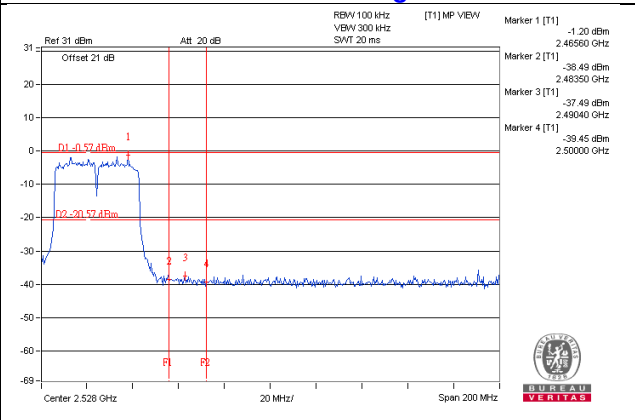

Chain 1

CH 3

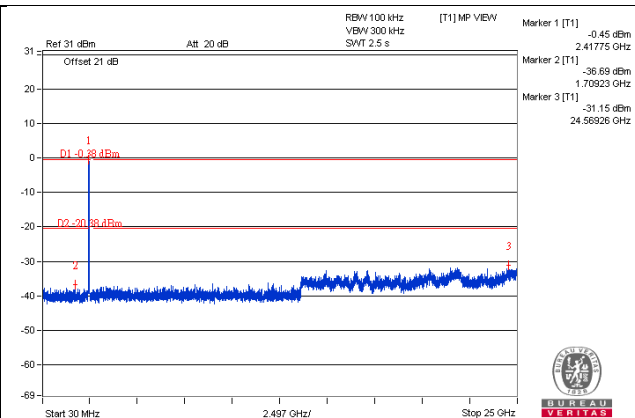
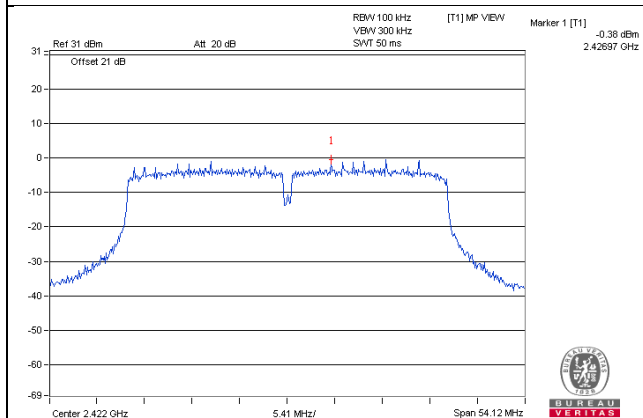

CH 6

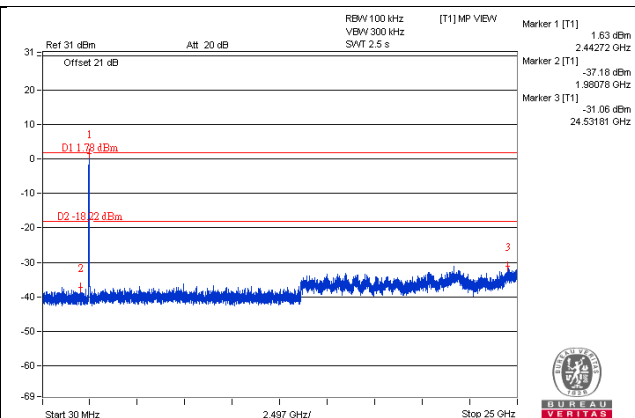
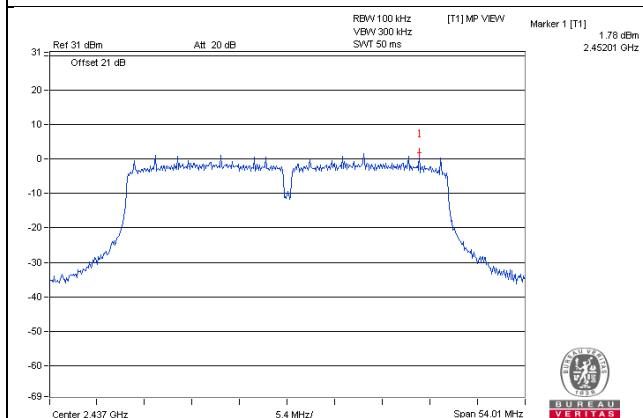

CH 9

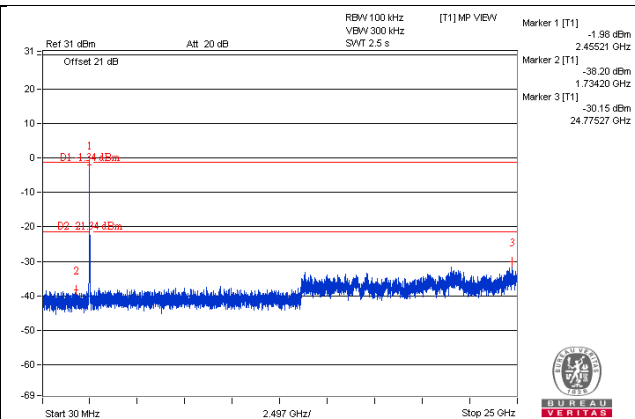
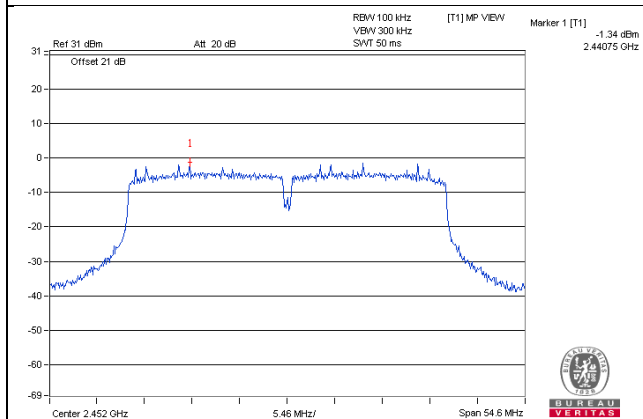

CH 3 Band edge

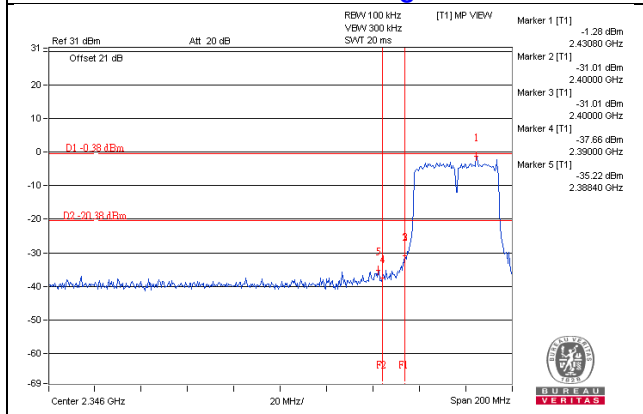

CH 9 Band edge

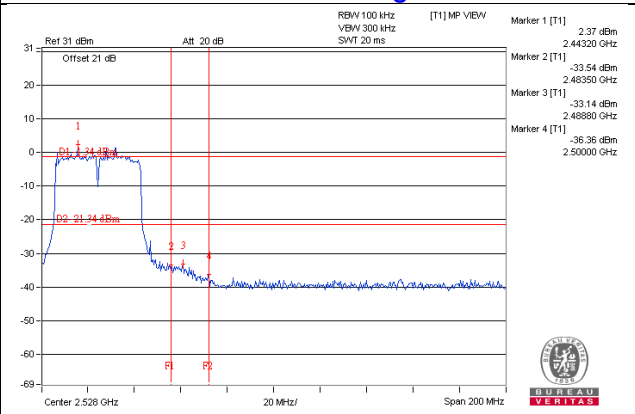

5 Pictures of Test Arrangements

Please refer to the attached file (Test Setup Photo).

Appendix – Information on the Testing Laboratories

We, Bureau Veritas Consumer Products Services (H.K.) Ltd., Taoyuan Branch, were founded in 1988 to provide our best service in EMC, Radio, Telecom and Safety consultation. Our laboratories are accredited and approved according to ISO/IEC 17025.

If you have any comments, please feel free to contact us at the following:

Linko EMC/RF Lab

Tel: 886-2-26052180

Fax: 886-2-26051924

Hsin Chu EMC/RF/Telecom Lab

Tel: 886-3-6668565

Fax: 886-3-6668323

Hwa Ya EMC/RF/Safety Lab

Tel: 886-3-3183232

Fax: 886-3-3270892

Email: service.adt@tw.bureauveritas.com

Web Site: www.bureauveritas-adt.com

The address and road map of all our labs can be found in our web site also.

--- END ---