

# FCC 47 CFR PART15 SUBPART E

## Test Report

For

Product Name: ClickShare CSE-200

Brand Name: Barco

Model No.: R9861520

Series Model.: N/A

FCC ID: 2AAED-R9861520

IC: 9393B-R9861520

Test Report Number:

C151211R01-RPW2

Issued for

Barco NV

President Kennedypark 35, 8500 Kortrijk, Belgium

Issued by

Compliance Certification Services Inc.

Kun shan Laboratory

No.10 Weiye Rd., Innovation park, Eco&Tec,  
Development Zone, Kunshan City, Jiangsu, China

TEL: 86-512-57355888

FAX: 86-512-57370818



TESTING CERT #2541.01

**Note:** This report shall not be reproduced except in full, without the written approval of Compliance Certification Services Inc. This document may be altered or revised by Compliance Certification Services Inc. personnel only, and shall be noted in the revision section of the document. The client should not use it to claim product endorsement by A2LA or any government agencies. The test results in the report only apply to the tested sample.

## TABLE OF CONTENTS

<b>1</b>	<b>TEST RESULT CERTIFICATION</b> .....	<b>3</b>
<b>2</b>	<b>EUT DESCRIPTION</b> .....	<b>4</b>
<b>3</b>	<b>TEST METHODOLOGY</b> .....	<b>5</b>
3.1	EUT CONFIGURATION .....	5
3.2	EUT EXERCISE.....	5
3.3	GENERAL TEST PROCEDURES.....	5
3.4	FCC PART 15.205 RESTRICTED BANDS OF OPERATIONS .....	6
3.5	DESCRIPTION OF TEST MODES.....	7
3.6	ANTENNA DESCRIPTION.....	8
<b>4</b>	<b>INSTRUMENT CALIBRATION</b> .....	<b>9</b>
4.1	MEASUREMENT EQUIPMENT USED .....	9
4.2	MEASUREMENT UNCERTAINTY .....	11
<b>5</b>	<b>FACILITIES AND ACCREDITATIONS</b> .....	<b>12</b>
5.1	FACILITIES.....	12
5.2	EQUIPMENT.....	12
5.3	TABLE OF ACCREDITATIONS AND LISTINGS .....	12
5.4	TABLE OF ACCREDITATIONS AND LISTINGS.....	13
<b>6</b>	<b>SETUP OF EQUIPMENT UNDER TEST</b> .....	<b>14</b>
6.1	SETUP CONFIGURATION OF EUT.....	14
6.2	SUPPORT EQUIPMENT.....	14
<b>7</b>	<b>FCC PART 15 REQUIREMENTS</b> .....	<b>15</b>
7.1	6 DB BANDWIDTH MEASUREMENT .....	15
7.2	99% BANDWIDTH MEASUREMENT .....	G23
7.3	MAXIMUM CONDUCTED OUTPUT POWER .....	31
7.4	BAND EDGES MEASUREMENT .....	33
7.5	POWER SPECTRAL DENSITY.....	36
7.6	RADIATED UNDESIRABLE EMISSION .....	44
7.7	POWERLINE CONDUCTED EMISSIONS .....	52

**1 TEST RESULT CERTIFICATION**

<b>Product Name:</b>	ClickShare CSE-200
<b>Trade Name:</b>	Barco
<b>Model Name.:</b>	R9861520
<b>Series Model:</b>	N/A
<b>Applicant Discrepancy:</b>	Initial
<b>Device Category:</b>	Portable device
<b>Date of Test:</b>	December 20, 2015 ~ January 10, 2016
<b>Applicant:</b>	<b>Barco NV</b> President Kennedypark 35, 8500 Kortrijk, Belgium
<b>Manufacturer:</b>	<b>Barco NV</b> President Kennedypark 35, 8500 Kortrijk, Belgium
<b>Application Type:</b>	Certification

APPLICABLE STANDARDS	
STANDARD	TEST RESULT
FCC 47 CFR Part 15 Subpart E	No non-compliance noted
Canada RSS-247 Issue 1	No non-compliance noted
Canada RSS-Gen Issue 4	No non-compliance noted

The above equipment was tested by Compliance Certification Services Inc. The test data, data evaluation, test procedures, and equipment configurations shown in this report were made in accordance with the procedures given in ANSI C63.10: 2013 and the energy emitted by the sample EUT tested as described in this report is in compliance with the requirements of FCC Rules Part 15.207, 15.209, 15.407 and KDB 789033.

The test results of this report relate only to the tested sample EUT identified in this report.

**Approved by:**

**Tested by:**

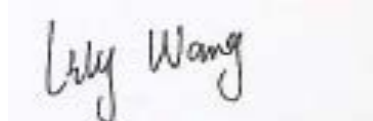
Jeff.Fang

Lily.Wang

RF Manager

Test Engineer

Compliance Certification Service Inc.

Compliance Certification Service Inc.

## 2 EUT DESCRIPTION

<b>Product Name:</b>	ClickShare CSE-200
<b>Brand Name:</b>	Barco
<b>Model Name:</b>	R9861520
<b>Series Model:</b>	N/A
<b>Model Discrepancy:</b>	N/A
<b>Power Adapter:</b>	Brand Name: GLOBTEK Model :GT-46180-1812 Input: 100-240V~0.6A 50-60Hz Output: DC12V 1.5A
<b>Frequency Range :</b>	5725MHz-5850MHz
<b>Transmit Power :</b>	IEEE802.11a mode: 13.26dBm IEEE802.11an HT20 mode: 11.28dBm
<b>Modulation Technique :</b>	IEEE802.11a mode: OFDM (6,9,12,18,24,36,48 and 54 Mbps) IEEE802.11an HT20 mode: OFDM (MCS0~MCS7)
<b>Number of Channels :</b>	IEEE 802.11a mode: 5 Channels IEEE 802.11an HT20de: 5 Channels
<b>Antenna Specification:</b>	dipole antenna1 for 5GHz Gain 2.0dBi dipole antenna2 for 5GHz Gain 2.0dBi

**Remark:**

1. The sample selected for test was engineering sample that approximated to production product and was provided by manufacturer.
2. This submittal(s) (test report) is intended for **FCC ID: 2AAED-R9861520** filing to comply with FCC Part 15, Subpart E Rules.
3. This submittal(s) (test report) is intended for **IC: 9393B-R9861520** filing to comply with Canada RSS-247 Issue 1 and Canada RSS-Gen Issue 4 Rules.

### **3 TEST METHODOLOGY**

The tests documented in this report were performed in accordance with ANSI C63.10:2013 and FCC CFR 47 15.207, 15.209 and 15.407,RSS-247.

#### **3.1 EUT CONFIGURATION**

The EUT configuration for testing is installed for RF field strength measurement to meet the Commissions requirement, and is operated in a manner intended to generate the maximum emission in a continuous normal application.

#### **3.2 EUT EXERCISE**

The EUT is operated in the engineering mode to fix the Tx frequency for the purposes of measurement.

According to its specifications, the EUT must comply with the requirements of Section 15.407 under the FCC Rules Part 15 Subpart E.

#### **3.3 GENERAL TEST PROCEDURES**

##### **Conducted Emissions**

The EUT is placed on the turntable, which is positioned at 0.8 m above the ground plane. According to the requirements in Section 13.3 of ANSI C63.10:2013, the conducted emission from the EUT is measured in the frequency range between 0.15 MHz and 30MHz, using the CISPR Quasi-Peak detector mode.

##### **Radiated Emissions**

###### **Under 1GHz**

The EUT is placed on a turn table, which is 0.8 m above ground plane. The turntable shall rotate 360 degrees to determine the position of maximum emission level. EUT is set 3m away from the receiving antenna, which varied from 1m to 4m to find out the highest emission. And also, each emission was to be maximized by changing the polarization of receiving antenna both horizontal and vertical. In order to find out the maximum emissions, exploratory radiated emission measurements were made according to the requirements in Section 13.1.4.1 of ANSI C63.10:2013.

###### **Above 1GHz**

The EUT is placed on a turn table, which is 1.5 m above ground plane. The turntable shall rotate 360 degrees to determine the position of maximum emission level. EUT is set 3m away from the receiving antenna, which varied from 1m to 4m to find out the highest emission. And also, each emission was to be maximized by changing the polarization of receiving antenna both horizontal and vertical. In order to find out the maximum emissions, exploratory radiated emission measurements were made according to the requirements in Section 13.1.4.1 of ANSI C63.10:2013.

### 3.4 FCC PART 15.205 RESTRICTED BANDS OF OPERATIONS

(a) Except as shown in paragraph (d) of this section, only spurious emissions are permitted in any of the frequency bands listed below:

MHz	MHz	MHz	GHz
0.090 - 0.110	16.42 - 16.423	399.9 - 410	4.50 - 5.15
0.495 - 0.505 <sup>(1)</sup>	16.69475 - 16.69525	608 - 614	5.35 - 5.46
2.1735 - 2.1905	16.80425 - 16.80475	960.0 - 1240	7.25 - 7.75
4.125 - 4.128	25.50 - 25.67	1300 - 1427	8.025 - 8.500
4.17725 - 4.17775	37.50 - 38.25	1435.0 - 1626.5	9.0 - 9.2
4.20725 - 4.20775	73.00 - 74.60	1645.5 - 1646.5	9.3 - 9.5
6.215 - 6.218	74.80 - 75.20	1660 - 1710	10.6 - 12.7
6.26775 - 6.26825	108.00 - 121.94	1718.8 - 1722.2	13.25 - 13.4
6.31175 - 6.31225	123 - 138	2200 - 2300	14.47 - 14.5
8.291 - 8.294	149.90 - 150.05	2310 - 2390	15.35 - 16.2
8.362 - 8.366	156.52475 - 156.52525	2483.5 - 2500.0	17.7 - 21.4
8.37625 - 8.38675	156.70 - 156.90	2655 - 2900	22.01 - 23.12
8.41425 - 8.41475	162.0125 - 167.1700	3260 - 3267	23.6 - 24.0
12.29 - 12.293	167.72 - 173.20	3332 - 3339	31.2 - 31.8
12.51975 - 12.52025	240 - 285	3345.8 - 3358.0	36.43 - 36.5 <sup>(2)</sup>
12.57675 - 12.57725	322.0 - 335.4	3600 - 4400	
13.36 - 13.41			

<sup>1</sup> Until February 1, 1999, this restricted band shall be 0.490-0.510 MHz.

<sup>2</sup> Above 38.6

(b) Except as provided in paragraphs (d) and (e), the field strength of emissions appearing within these frequency bands shall not exceed the limits shown in Section 15.209. At frequencies equal to or less than 1000 MHz, compliance with the limits in Section 15.209 shall be demonstrated using measurement instrumentation employing a CISPR quasi-peak detector. Above 1000 MHz, compliance with the emission limits in Section 15.209 shall be demonstrated based on the average value of the measured emissions. The provisions in Section 15.35 apply to these measurements.

### 3.5 DESCRIPTION OF TEST MODES

Description	Modulation Technology	Modulation Type
6dB Bandwidth and 99% Bandwidth	OFDM	BPSK
Maximum conducted output power	OFDM	BPSK
Band edges measurement	OFDM	BPSK
Peak Power Spectral Density	OFDM	BPSK
Radiated undesirable emission	OFDM	BPSK
Conducted undesirable emission	OFDM	BPSK
Powerline conducted emission	OFDM	BPSK

The EUT transmitting and receiving with two antennas working at a/an mode, Both chain0 and chain1 could be used as transmit/receiving antenna,so 2x2 configuration was used for all testing in this report.

Software used to control the EUT for staying in continuous transmitting mode was programmed.

**IEEE 802.11a mode:**

Channel Low (5745MHz), Channel Mid (5785MHz) and Channel High (5825MHz) with 24Mbps data rate were chosen for full testing.

**IEEE 802.11an HT20 mode:**

Channel Low (5745MHz), Channel Mid (5785MHz) and Channel High (5825MHz) with MCS0 data rate were chosen for full testing.

### 3.6 ANTENNA DESCRIPTION

an intentional radiator antenna shall be designed to ensure that no antenna other than that furnished by the responsible party can be used with the device. The use of a permanently attached or an antenna that uses a unique coupling to the intentional radiator shall be considered sufficient to comply with the provisions of this section”

\* the antenna of this EUT is a unique(dipole Antenna for 5G WiFi).

\* the EUT complies with the requirement of 15.203.

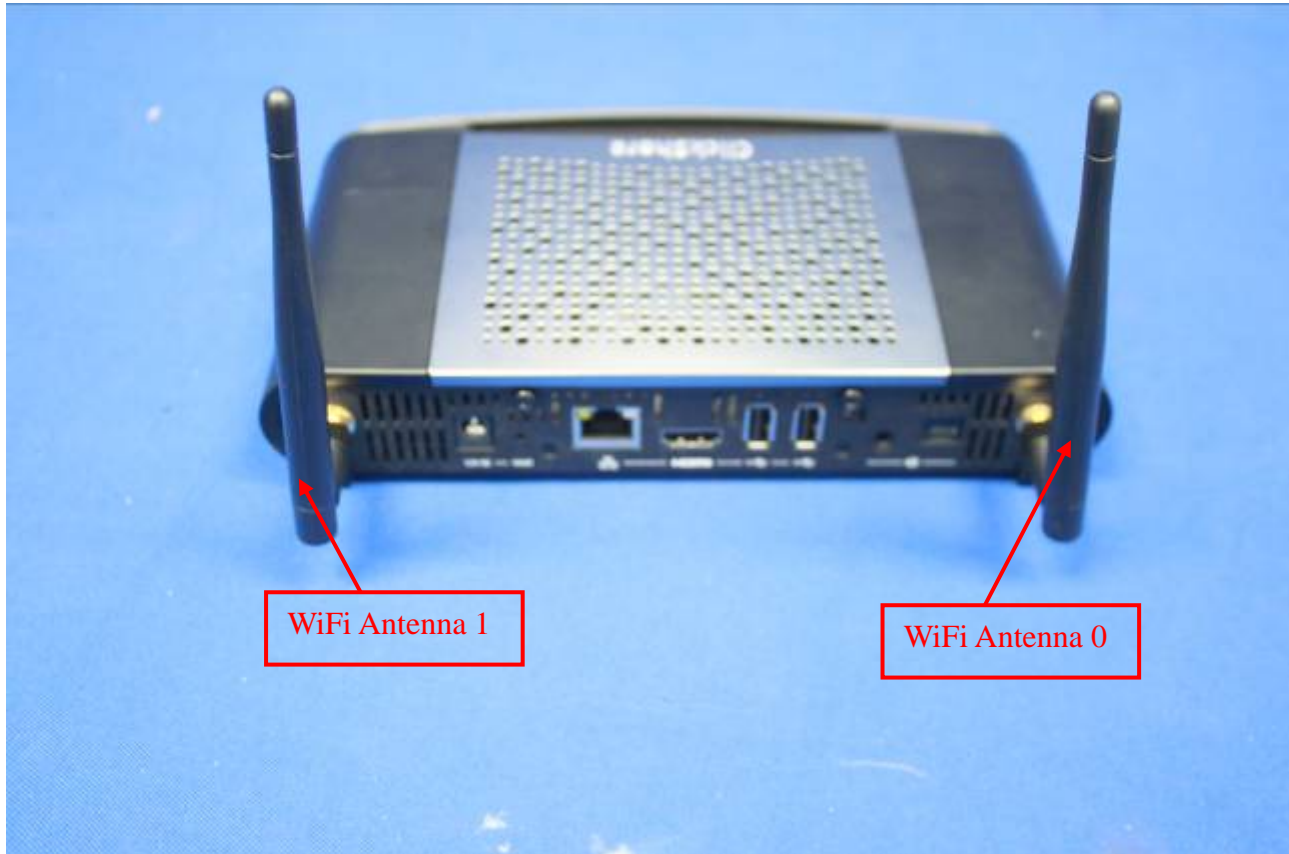



## 4 INSTRUMENT CALIBRATION

The measuring equipment, which was utilized in performing the tests documented herein, has been calibrated in accordance with the manufacturer's recommendations for utilizing calibration equipment, which is traceable to recognized national standards.

### 4.1 MEASUREMENT EQUIPMENT USED

Conducted Emissions Test Site					
Name of Equipment	Manufacturer	Model	Serial Number	Calibration Date	Calibration Due
Spectrum Analyzer	Agilent	E4446A	MY44020154	2015-4-9	2016-4-8
DETECTOR NEGATIVE	Agilent	8473B	MY42240176	2015-5-11	2016-5-10
OSCILLOSCOPE	Agilent	DSO6104A	MY44002585	2015-3-16	2016-3-15
Power Sensor	Anritsu	MA2411A	0917072	2015-4-24	2016-4-23
Power Meter	Aglient	U2021XA	MY53120005	2015-4-24	2016-4-23
Power SPLITTER	Mini-Circuits	ZN2PD-9G	SF078500430	N.C.R	N.C.R
DC Power Supply	AGILENT	E3632A	MY50340053	N.C.R	N.C.R
Temp. / Humidity Chamber	TERCHY	MHK-120AK	X30109	2015-1-22	2016-1-21
Power SPLITTER	Mini-Circuits	ZN2PD-9G	SF078500430	N.C.R	N.C.R
DC POWER SUPPLY	GW instek	GPS-3303C	E903131	N.C.R	N.C.R
Temp. / Humidity Chamber	Kingson	THS-M1	242	2015-1-22	2016-1-21

977 Chamber					
Name of Equipment	Manufacturer	Model	Serial Number	Calibration Date	Calibration Due
Spectrum Analyzer	Agilent	E4446A	MY44020154	2015-4-9	2016-4-8
EMI Test Receiver	R&S	ESCI	101378	2015-1-22	2016-1-21
Pre-Amplifier	MINI	ZFL-1000VH2	d041703	2015-1-22	2016-1-21
Pre-Amplifier	Miteq	JS41-00101800-32-10P	1675713	2015-1-22	2016-1-21
Bilog Antenna	Sunol	JB1	A062604	2015-3-6	2016-3-5
Horn-antenna	SCHWARZBECK	BBHA9120D	D:266	2015-3-7	2016-3-6
Turn Table	CT	CT123	4165	N.C.R	N.C.R
Antenna Tower	CT	CTERG23	3256	N.C.R	N.C.R
Controller	CT	CT100	95637	N.C.R	N.C.R
Test Software			EZ-EMC		

Conducted Emission					
Name of Equipment	Manufacturer	Model	Serial Number	Calibration Date	Calibration Due
EMI TEST RECEIVER	R&S	ESCI	100781	2015-3-16	2016-3-15
V (V-LISN)	SCHWARZBECK	NNLK 8129	8129-143	N.C.R	N.C.R
LISN (EUT)	FCC	FCC-LISN-50/250-50-2-02	05012	2015-3-16	2016-3-15
Pulse LIMITER	R&S	ESH3-Z2	100524	2015-9-24	2016-9-23
Test Software	EZ-EMC				

**Remark:** Each piece of equipment is scheduled for calibration once a year.

## 4.2 MEASUREMENT UNCERTAINTY

For the test methods, according to the present document, the measurement uncertainty figures shall be calculated in accordance with TR 100 028-1 [2] and shall correspond to an expansion factor (coverage factor)  $k = 1,96$  or  $k = 2$  (which provide confidence levels of respectively 95 % and 95,45 % in the case where the distributions characterizing the actual measurement uncertainties are normal (Gaussian)).

Table 6 is based on such expansion factors.

**Table 6: Maximum measurement uncertainty**

Parameter	<u>UNCERTAINTY</u>
Radio frequency	$\pm 0.8 \times 10^{-7}$
RF power, conducted	0.2054
Maximum frequency deviation:	
-within 300 Hz and 6 kHz of audio frequency	1.3%
-within 6 kHz and 25 kHz of audio frequency	0.65 dB
Adjacent channel power	0.2054
Conducted spurious emission of transmitter, valid up to 6 GHz	0.2892
Conducted emission of receivers	+1.2/-1.1 dB
Radiated emission of transmitter, valid up to 6 GHz	$\pm 3.94$ dB
Radiated emission of receiver, valid up to 6 GHz	$\pm 3.94$ dB
RF level uncertainty for a given BER	$\pm 0.3$ dB
Temperature	0.1979
Humidity	$\pm 1$ %

## **5 FACILITIES AND ACCREDITATIONS**

### **5.1 FACILITIES**

All measurement facilities used to collect the measurement data are located at

**No.10Weiye Rd., Innovation park, Eco&Tec, Development Zone, Kunshan City, Jiangsu, China.**

The sites are constructed in conformance with the requirements of ANSI C63.10:2013 and CISPR Publication 22. All receiving equipment conforms to CISPR Publication 16-1, "Radio Interference Measuring Apparatus and Measurement Methods."

### **5.2 EQUIPMENT**

Radiated emissions are measured with one or more of the following types of linearly polarized antennas: tuned dipole, biconical, log periodic, bi-log, and/or ridged waveguide, horn. Spectrum analyzers with preselectors and quasi-peak detectors are used to perform radiated measurements.

Conducted emissions are measured with Line Impedance Stabilization Networks and EMI Test Receivers.



Calibrated wideband preamplifiers, coaxial cables, and coaxial attenuators are also used for making measurements.

All receiving equipment conforms to CISPR Publication 16-1, "Radio Interference Measuring Apparatus and Measurement Methods."

### **5.3 TABLE OF ACCREDITATIONS AND LISTINGS**

The test facilities used to perform radiated and conducted emissions tests are accredited by American Association for Laboratory Accreditation Program for the specific scope accreditation under Lab Code: 200581-0 to perform Electromagnetic Interference tests according to FCC Part 15 and CISPR 22 requirements. In addition, the test facilities are listed with Industry Canada, Certification and Engineering Bureau, 2324E-1 for 10m chamber 10m, 2324E-2 for 10m chamber 3m; the test facilities are listed with USA, Certification and Engineering Bureau, 424105 for 10m chamber 10m, 238958 for 10m chamber 3m.

**5.4 TABLE OF ACCREDITATIONS AND LISTINGS**

Country	Agency	Scope of Accreditation	Logo
USA	A2LA	47 CFR FCC Part 15/18 (using ANSI C63.10 :2013); VCCI V3; CNS 13438; CNS 13439; CNS 13803; CISPR 11; EN 55011; CISPR 13; EN 55013; CISPR 22:2005; CISPR 22:1997 +A1 :2000+A2 :2002; EN 55022:2006; EN55022 :1998 +A1 :2001+A2 :2003; EN 61000-6-3 (excluding discontinuous interference); EN 61000-6-4; AS/NZS CISPR 22; CAN/CSA-CEI/IEC CISPR 22; EN 61000-3-2; EN 61000-3-3; EN550024; EN 61000-4-2; EN 61000-4-3; EN61000-4-4; EN 61000-4-5; EN 61000-4-6; IEC 61000-4-8; EN 61000-4-11; IEC61000-3-2; IEC61000-3-3; IEC 61000-4-2; IEC 61000-4-3; IEC 61000-4-4; IEC 61000-4-5; IEC 61000-4-6; IEC 61000-4-8; IEC 61000-4-11; EN 300 220-3; EN 300 328; EN 300 330-2; EN 300 440-1; EN 300-440-2; EN 300 893; EN 301 489-01; EN 301 489-3; EN 301 489-07; EN 301 489-17; 47 CFR FCC Part 15, 22, 24	
USA	FCC	3/10 meter Sites to perform FCC Part 15/18 measurements	 93105, 90471
Japan	VCCI	3/10 meter Sites and conducted test sites to perform radiated/conducted measurements	<b>VCCI</b> R-1600 C-1707 G-216

*\* No part of this report may be used to claim or imply product endorsement by A2LA or any agency of the US Government.*

## 6 SETUP OF EQUIPMENT UNDER TEST

### 6.1 SETUP CONFIGURATION OF EUT

See test photographs attached in Appendix 1 for the actual connections between EUT and support equipment.

### 6.2 SUPPORT EQUIPMENT

No.	Equipment	Model No.	Serial No.
1	Notebook	dell	E5430

**Remark:**

1. All the equipment/cables were placed in the worst-case configuration to maximize the emission during the test.
2. Grounding was established in accordance with the manufacturer's requirements and conditions for the intended use.

## 7 FCC PART 15 REQUIREMENTS

### 7.1 6 DB BANDWIDTH MEASUREMENT

#### LIMIT

Section 15.407(e) specifies the minimum 6 dB emission bandwidth of at least 500 KHz for the band 5.715-5.85 GHz.

#### Test Configuration

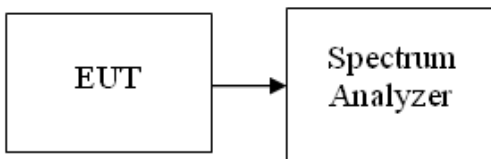

#### TEST PROCEDURE

1. Place the EUT on the table and set it in the transmitting mode.
2. Remove the antenna from the EUT and then connect a low-loss RF cable from the antenna port to the spectrum analyzer.
3. Set the spectrum analyzer as RBW =100KHz, VBW  $\geq$  3RBW, Detector = Peak. Trace mode = max hold.
4. Measure the maximum width of the emission that is 6 dB down from the peak of the emission..
5. Measure and record the results in the test report

#### TEST RESULTS

*No non-compliance noted*

#### Test Data

**Test mode: IEEE 802.11a mode/chain 0**

**5725~5850MHz**

Channel	Frequency (MHz)	6 dB Bandwidth (MHz)	FCC 6 dB Bandwidth Min. Limit (MHz)
Low	5745	16.538	0.5
Mid	5785	16.528	0.5
High	5825	16.460	0.5

**Test mode: IEEE 802.11a mode/chain 1**

**5725~5850MHz**

Channel	Frequency (MHz)	6 dB Bandwidth (MHz)	FCC 6 dB Bandwidth Min. Limit (MHz)
Low	5745	16.496	0.5
Mid	5785	16.556	0.5
High	5825	16.484	0.5

**Test mode: IEEE 802.11n HT20 mode/chain 0**

**5725~5850MHz**

Channel	Frequency (MHz)	6 dB Bandwidth (MHz)	FCC 6 dB Bandwidth Min. Limit (MHz)
Low	5745	17.308	0.5
Mid	5785	17.661	0.5
High	5825	17.470	0.5

**Test mode: IEEE 802.11n HT20 mode/chain 1**

**5725~5850MHz**

Channel	Frequency (MHz)	6 dB Bandwidth (MHz)	FCC 6 dB Bandwidth Min. Limit (MHz)
Low	5745	17.624	0.5
Mid	5785	17.679	0.5
High	5825	17.725	0.5



**Test Plot**

**IEEE 802.11a mode/chain 0**

**6dB Bandwidth (CH Low)**

Agilent

R T

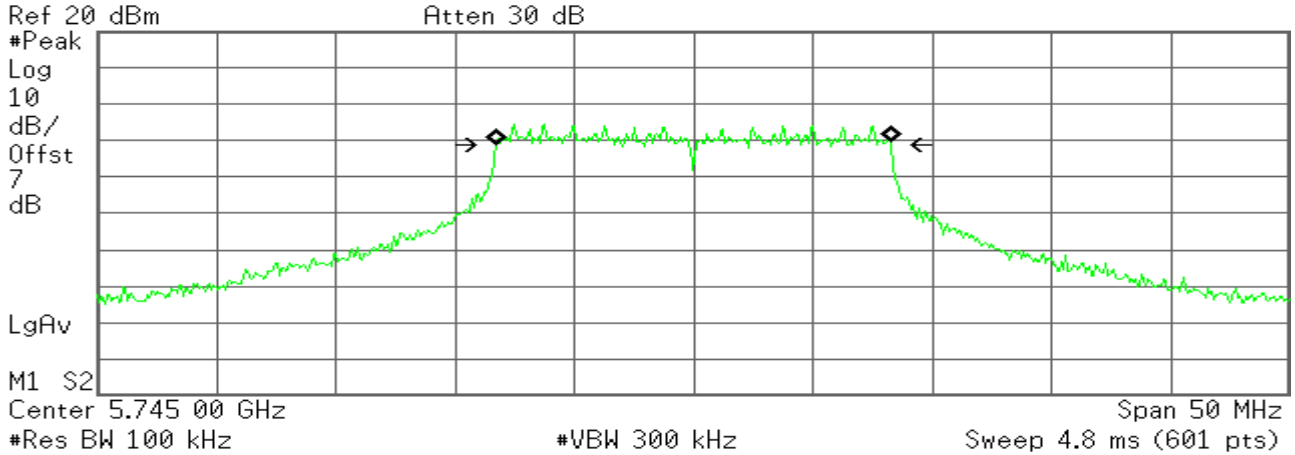

**Occupied Bandwidth**  
**16.4989 MHz**

**Occ BW % Pwr** 99.00 %  
**x dB** -6.00 dB

**Transmit Freq Error** -16.200 kHz  
**x dB Bandwidth** 16.538 MHz

**6dB Bandwidth (CH Mid)**

Agilent

R T

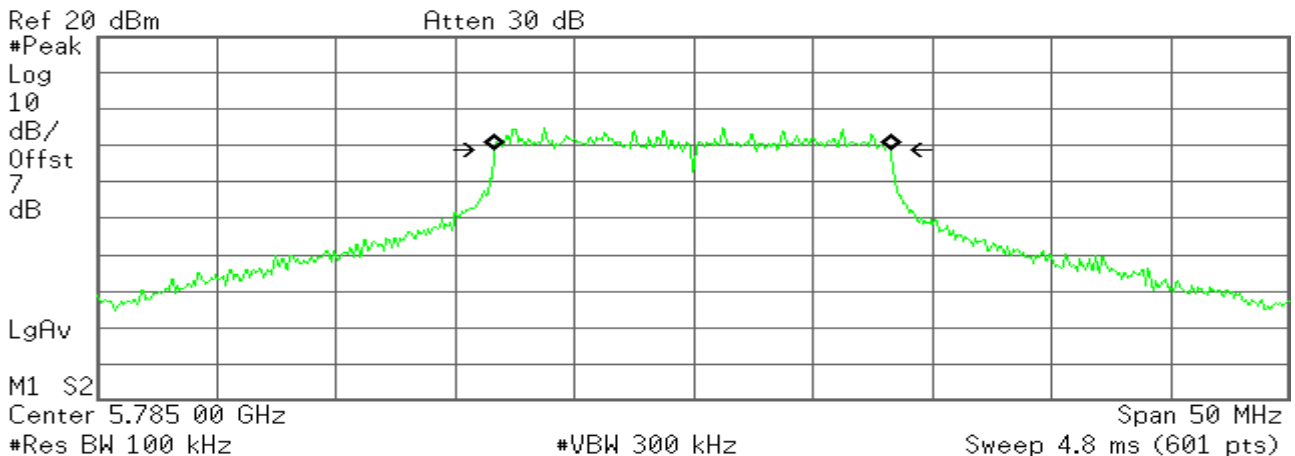

**Occupied Bandwidth**  
**16.5228 MHz**

**Occ BW % Pwr** 99.00 %  
**x dB** -6.00 dB

**Transmit Freq Error** -47.191 kHz  
**x dB Bandwidth** 16.528 MHz

**6dB Bandwidth (CH High)**

Agilent

R T

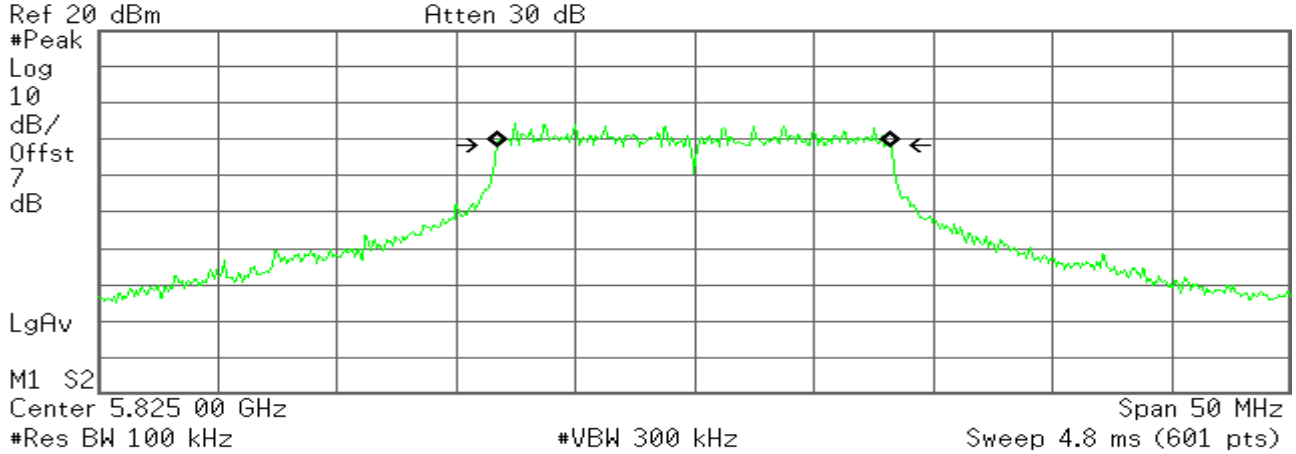

**Occupied Bandwidth**  
**16.4807 MHz**

**Occ BW % Pwr** 99.00 %  
**x dB** -6.00 dB

**Transmit Freq Error** -32.975 kHz  
**x dB Bandwidth** 16.460 MHz

**IEEE 802.11a mode/chain 1**

**6dB Bandwidth (CH Low)**

Agilent

R T

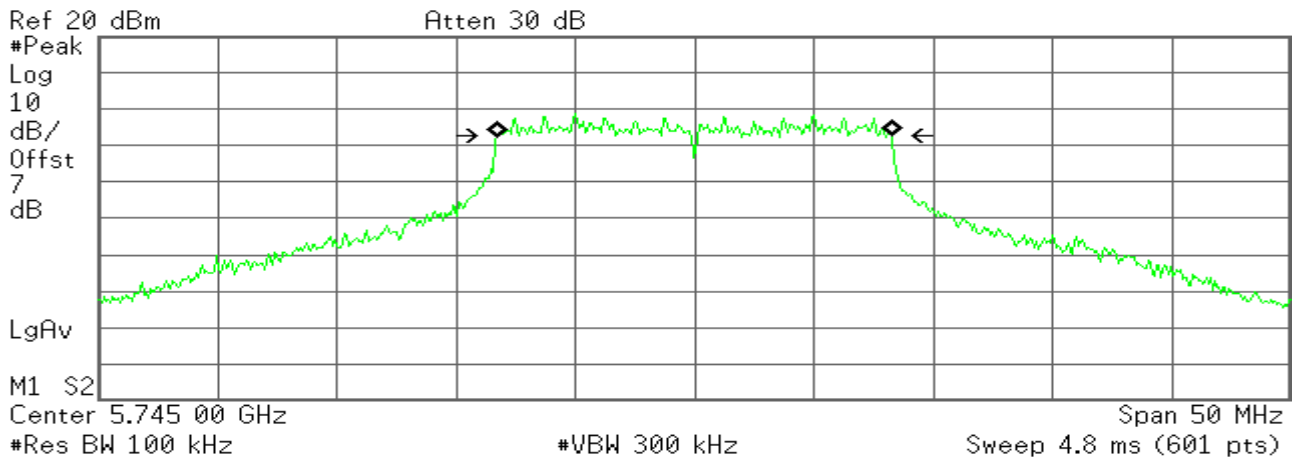

**Occupied Bandwidth**  
**16.5067 MHz**

**Occ BW % Pwr** 99.00 %  
**x dB** -6.00 dB

**Transmit Freq Error** -37.074 kHz  
**x dB Bandwidth** 16.496 MHz

**6dB Bandwidth (CH Mid)**

Agilent

R T

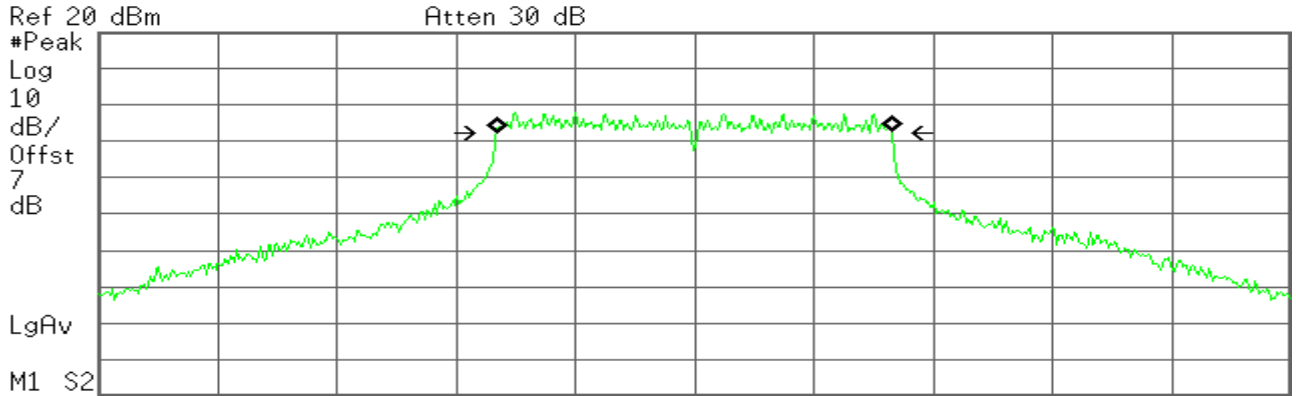

Ref 20 dBm Atten 30 dB  
 #Peak Log 10 dB/Offst 7 dB  
 LgAv  
 M1 S2  
 Center 5.785 00 GHz Span 50 MHz  
 #Res BW 100 kHz #VBW 300 kHz Sweep 4.8 ms (601 pts)

**Occupied Bandwidth**  
**16.5109 MHz**

**Occ BW % Pwr** 99.00 %  
**x dB** -6.00 dB

**Transmit Freq Error** -35.238 kHz  
**x dB Bandwidth** 16.556 MHz

**6dB Bandwidth (CH High)**

Agilent

R T

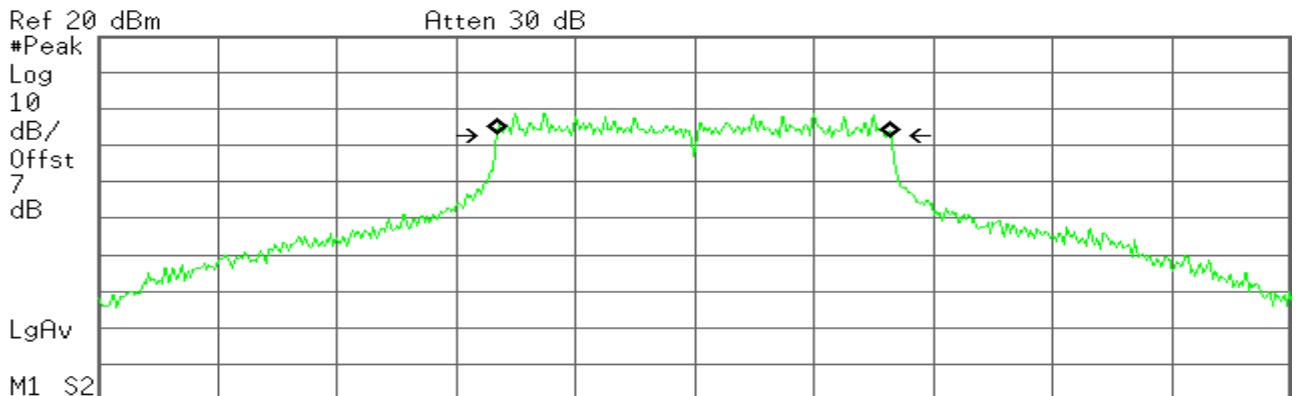

Ref 20 dBm Atten 30 dB  
 #Peak Log 10 dB/Offst 7 dB  
 LgAv  
 M1 S2  
 Center 5.825 00 GHz Span 50 MHz  
 #Res BW 100 kHz #VBW 300 kHz Sweep 4.8 ms (601 pts)

**Occupied Bandwidth**  
**16.4718 MHz**

**Occ BW % Pwr** 99.00 %  
**x dB** -6.00 dB

**Transmit Freq Error** -29.541 kHz  
**x dB Bandwidth** 16.484 MHz

**IEEE 802.11n HT20 mode/chain 0**

**6dB Bandwidth (CH Low)**

Agilent

R T

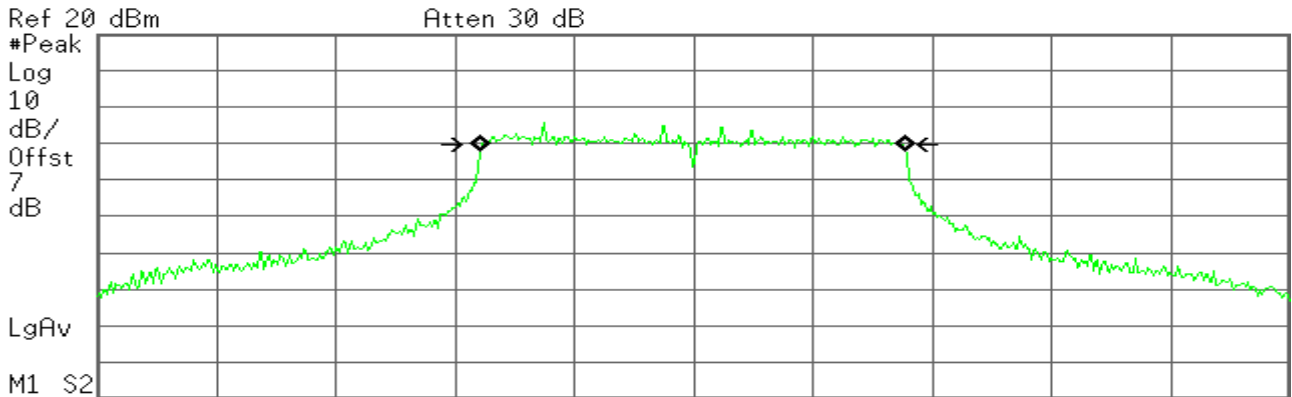

Ref 20 dBm Atten 30 dB  
 #Peak Log 10 dB/ Offst 7 dB  
 LgAv  
 M1 S2  
 Center 5.745 00 GHz Span 50 MHz  
 #Res BW 100 kHz #VBW 300 kHz Sweep 4.8 ms (601 pts)

**Occupied Bandwidth**  
**17.7520 MHz**

**Occ BW % Pwr** 99.00 %  
**x dB** -6.00 dB

**Transmit Freq Error** -32.021 kHz  
**x dB Bandwidth** 17.308 MHz

**6dB Bandwidth (CH Mid)**

Agilent

R T

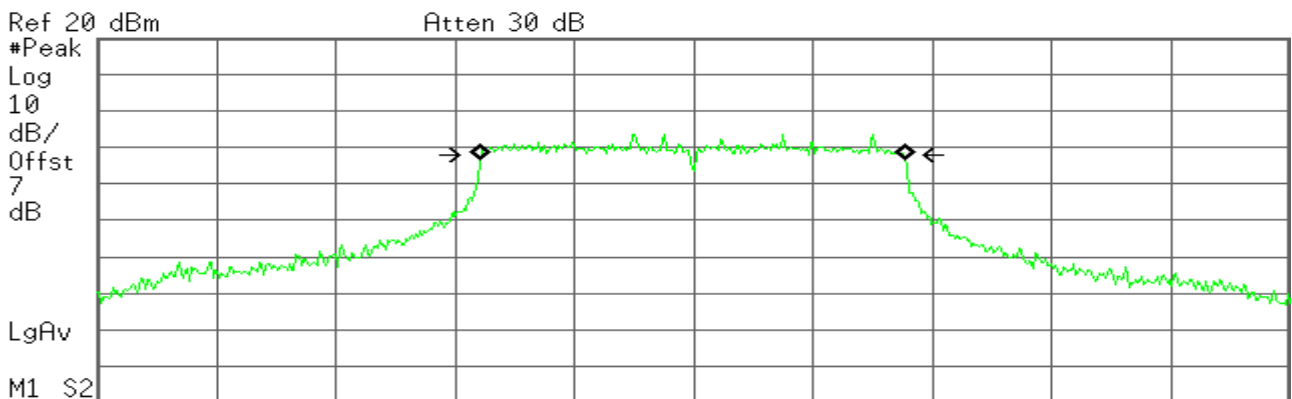

Ref 20 dBm Atten 30 dB  
 #Peak Log 10 dB/ Offst 7 dB  
 LgAv  
 M1 S2  
 Center 5.785 00 GHz Span 50 MHz  
 #Res BW 100 kHz #VBW 300 kHz Sweep 4.8 ms (601 pts)

**Occupied Bandwidth**  
**17.7301 MHz**

**Occ BW % Pwr** 99.00 %  
**x dB** -6.00 dB

**Transmit Freq Error** -34.128 kHz  
**x dB Bandwidth** 17.661 MHz

**6dB Bandwidth (CH High)**

Agilent

R T

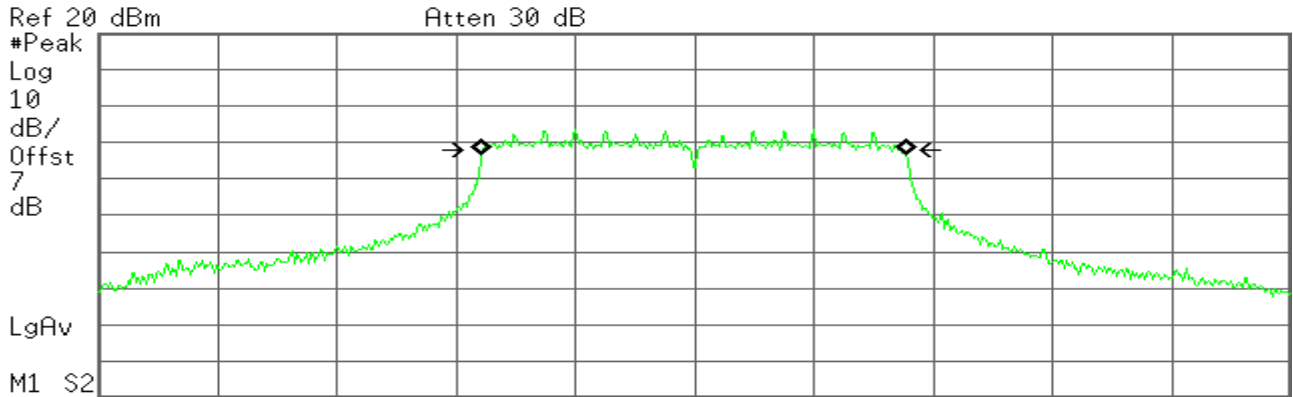

Ref 20 dBm Atten 30 dB  
 #Peak  
 Log  
 10  
 dB/  
 Offst  
 7  
 dB  
 LgAv  
 M1 S2  
 Center 5.825 00 GHz Span 50 MHz  
 #Res BW 100 kHz #VBW 300 kHz Sweep 4.8 ms (601 pts)

**Occupied Bandwidth**  
**17.7215 MHz**

**Occ BW % Pwr** 99.00 %  
**x dB** -6.00 dB

**Transmit Freq Error** -23.609 kHz  
**x dB Bandwidth** 17.470 MHz

**IEEE 802.11n HT20 mode/chain 1**

**6dB Bandwidth (CH Low)**

Agilent

R T

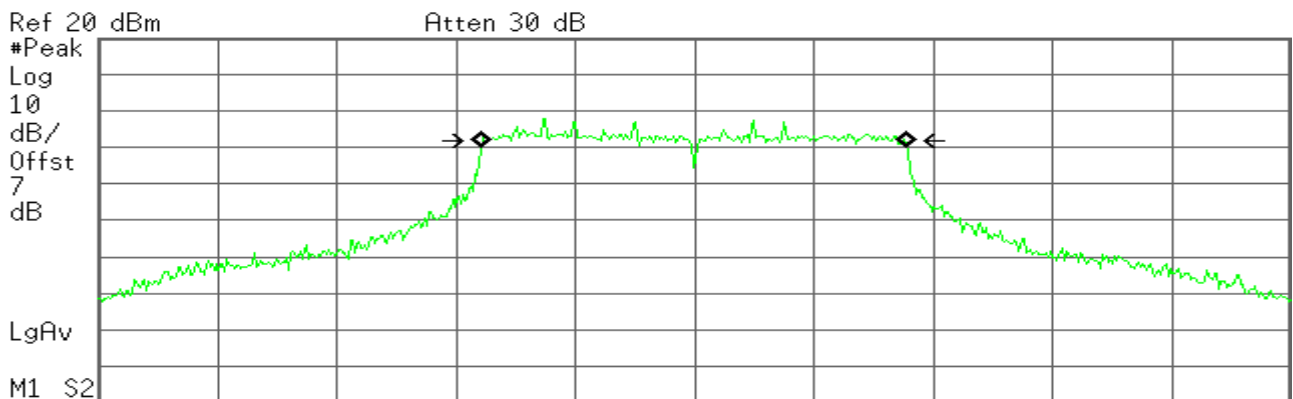

Ref 20 dBm Atten 30 dB  
 #Peak  
 Log  
 10  
 dB/  
 Offst  
 7  
 dB  
 LgAv  
 M1 S2  
 Center 5.745 00 GHz Span 50 MHz  
 #Res BW 100 kHz #VBW 300 kHz Sweep 4.8 ms (601 pts)

**Occupied Bandwidth**  
**17.7616 MHz**

**Occ BW % Pwr** 99.00 %  
**x dB** -6.00 dB

**Transmit Freq Error** -25.929 kHz  
**x dB Bandwidth** 17.624 MHz

**6dB Bandwidth (CH Mid)**

Agilent

R T

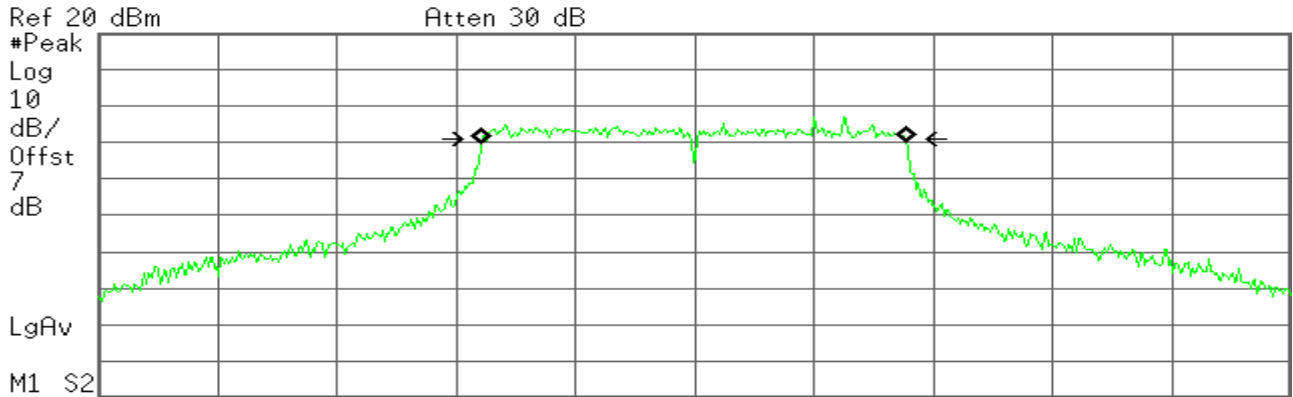

Ref 20 dBm Atten 30 dB  
 #Peak Log 10 dB/ Offst 7 dB  
 LgAv  
 M1 S2  
 Center 5.785 00 GHz Span 50 MHz  
 #Res BW 100 kHz #VBW 300 kHz Sweep 4.8 ms (601 pts)

**Occupied Bandwidth**  
**17.7512 MHz**

**Occ BW % Pwr** 99.00 %  
**x dB** -6.00 dB

**Transmit Freq Error** -30.239 kHz  
**x dB Bandwidth** 17.679 MHz

**6dB Bandwidth (CH High)**

Agilent

R T

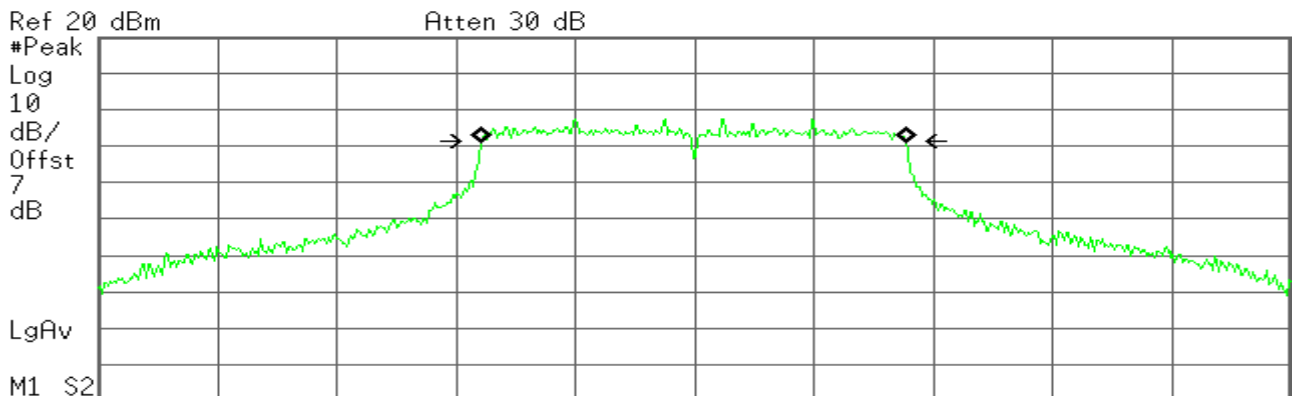

Ref 20 dBm Atten 30 dB  
 #Peak Log 10 dB/ Offst 7 dB  
 LgAv  
 M1 S2  
 Center 5.825 00 GHz Span 50 MHz  
 #Res BW 100 kHz #VBW 300 kHz Sweep 4.8 ms (601 pts)

**Occupied Bandwidth**  
**17.7685 MHz**

**Occ BW % Pwr** 99.00 %  
**x dB** -6.00 dB

**Transmit Freq Error** -39.230 kHz  
**x dB Bandwidth** 17.725 MHz

**7.2 99% BANDWIDTH MEASUREMENT**

**LIMIT**

None; for reporting purposes only  
RSS-Gen 4.6.1

**Test Configuration**

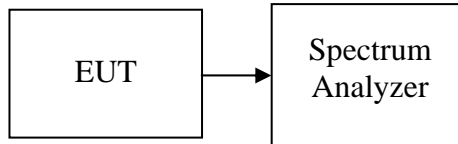

**TEST PROCEDURE**

The transmitter output is connected to the spectrum analyzer. The resolution bandwidth (RBW) shall be in the range of 1% to 5% of the occupied bandwidth (OBW) and video bandwidth (VBW) shall be approximately 3x RBW. The sweep time is coupled. The spectrum analyzer internal 99% bandwidth function is utilized.

**TEST RESULTS**

*No non-compliance noted*

**Test Data**

**IEEE 802.11a mode / Chain 0**

Channel	Frequency (MHz)	Bandwidth (MHz)
Low	5745	16.9328
Mid	5785	16.8154
High	5825	16.8156

**IEEE 802.11a mode / Chain 1**

Channel	Frequency (MHz)	Bandwidth (MHz)
Low	5745	16.8566
Mid	5785	16.8560
High	5825	16.9053

**IEEE 802.11n HT20 mode / Chain 0**

Channel	Frequency (MHz)	Bandwidth (MHz)
Low	5745	18.1413
Mid	5785	18.1896
High	5825	18.0824

**IEEE 802.11n HT20 mode / Chain 1**

Channel	Frequency (MHz)	Bandwidth (MHz)
Low	5745	18.0087
Mid	5785	18.2491
High	5825	18.3037

**Test Plot**

**IEEE 802.11n MODE/chain 0**

**99% Bandwidth (CH Low)**

Agilent

R T

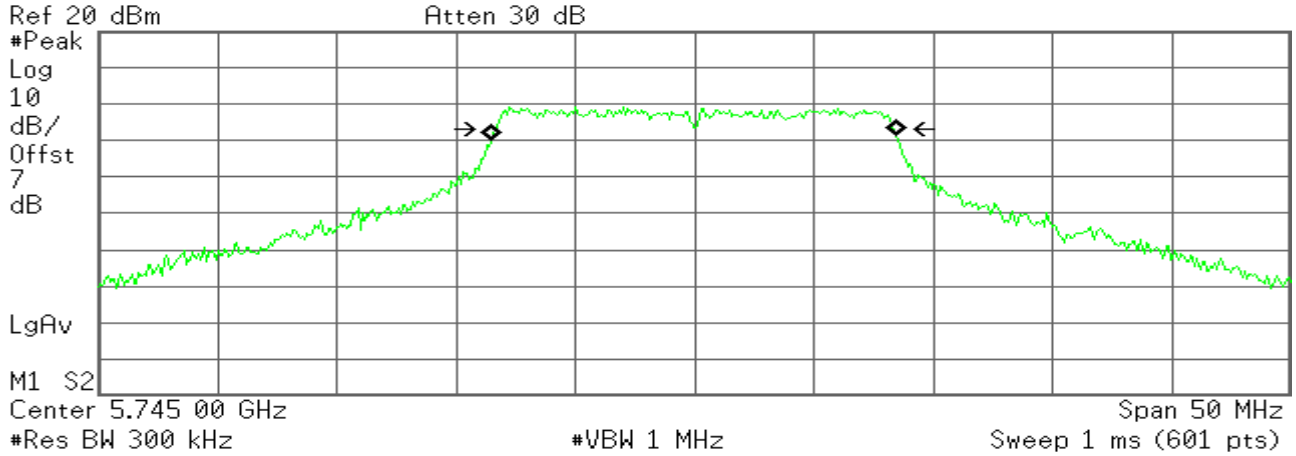

**Occupied Bandwidth**  
**16.9328 MHz**

**Occ BW % Pwr** 99.00 %  
**x dB** -6.00 dB

**Transmit Freq Error** -34.053 kHz  
**x dB Bandwidth** 16.603 MHz

**99% Bandwidth (CH Mid)**



 **Agilent**

**R T**

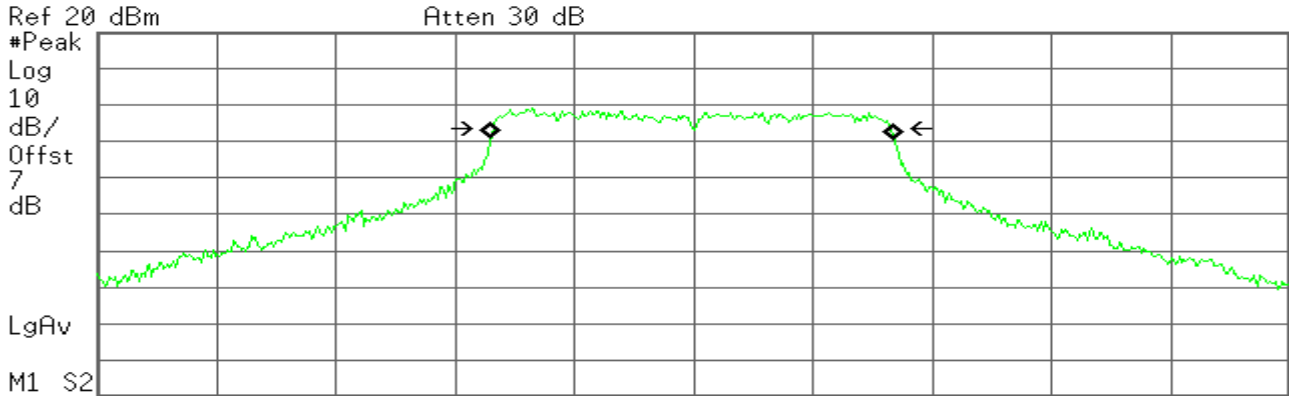

**Occupied Bandwidth**  
**16.8154 MHz**

**Occ BW % Pwr** 99.00 %  
**x dB** -6.00 dB

**Transmit Freq Error** -60.919 kHz  
**x dB Bandwidth** 16.647 MHz

**99% Bandwidth (CH High)**

Agilent

R T

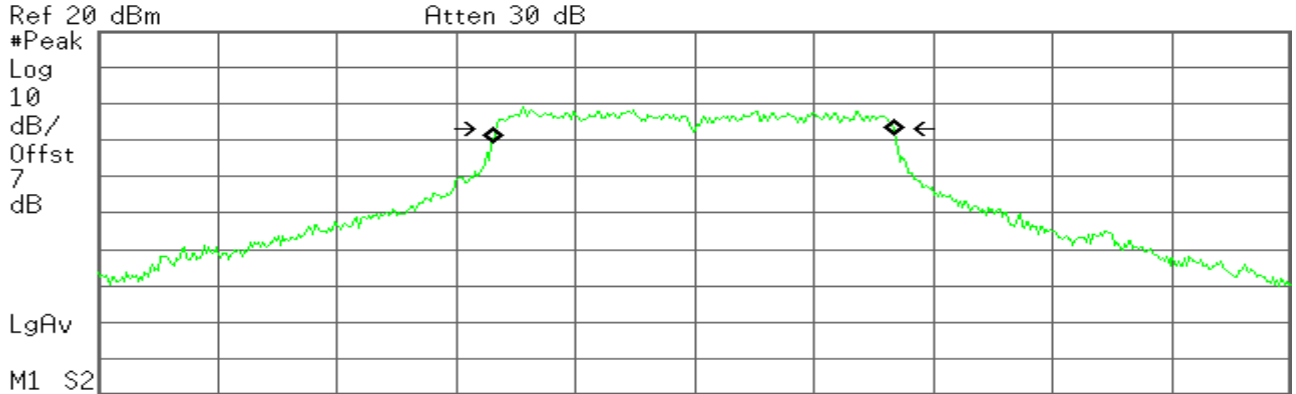

Ref 20 dBm Atten 30 dB  
 #Peak Log 10 dB/Offst 7 dB  
 LgAv  
 M1 S2  
 Center 5.825 00 GHz Span 50 MHz  
 #Res BW 300 kHz #VBW 1 MHz Sweep 1 ms (601 pts)

**Occupied Bandwidth**  
**16.8156 MHz**

**Occ BW % Pwr** 99.00 %  
**x dB** -6.00 dB

**Transmit Freq Error** -39.220 kHz  
**x dB Bandwidth** 16.656 MHz

**IEEE 802.11n MODE/chain 1**

**99% Bandwidth (CH Low)**

Agilent

R T

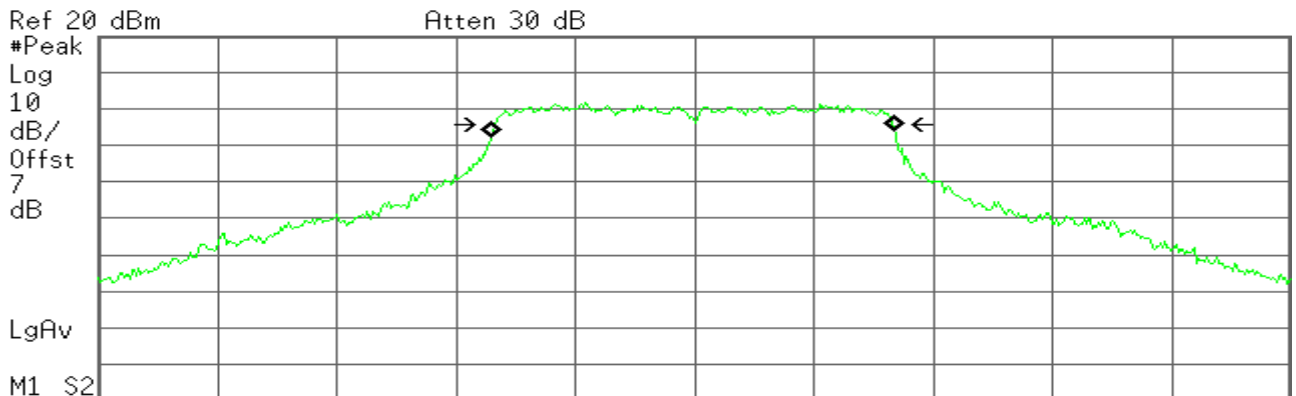

Ref 20 dBm Atten 30 dB  
 #Peak Log 10 dB/Offst 7 dB  
 LgAv  
 M1 S2  
 Center 5.745 00 GHz Span 50 MHz  
 #Res BW 300 kHz #VBW 1 MHz Sweep 1 ms (601 pts)

**Occupied Bandwidth**  
**16.8566 MHz**

**Occ BW % Pwr** 99.00 %  
**x dB** -6.00 dB

**Transmit Freq Error** -67.831 kHz  
**x dB Bandwidth** 16.615 MHz

**99% Bandwidth (CH Mid)**

Agilent

R T

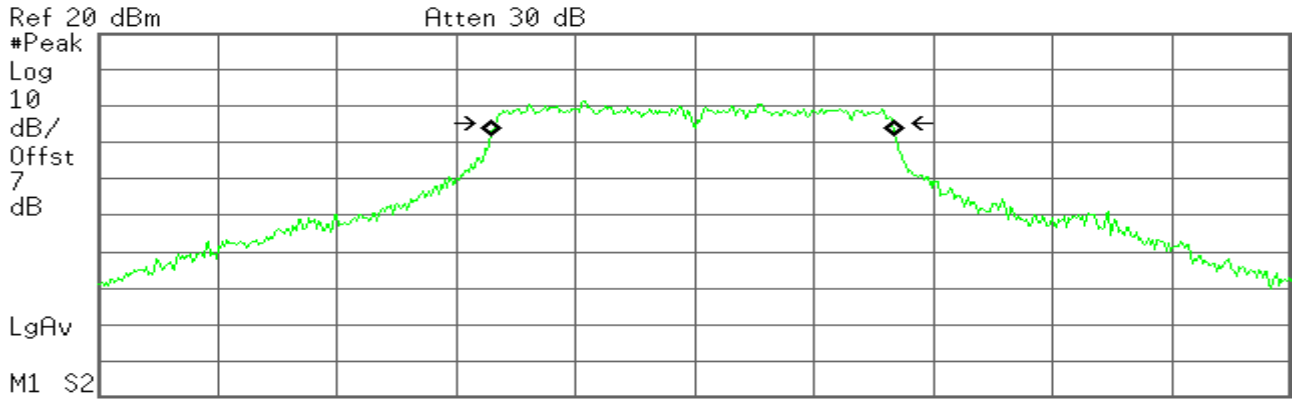

Ref 20 dBm Atten 30 dB  
 #Peak Log 10 dB/Offst 7 dB  
 M1 S2 Center 5.785 00 GHz Span 50 MHz  
 #Res BW 300 kHz #VBW 1 MHz Sweep 1 ms (601 pts)

**Occupied Bandwidth**  
**16.8560 MHz**

**Occ BW % Pwr** 99.00 %  
**x dB** -6.00 dB

**Transmit Freq Error** -92.263 kHz  
**x dB Bandwidth** 16.591 MHz

**99% Bandwidth (CH High)**

Agilent

R T

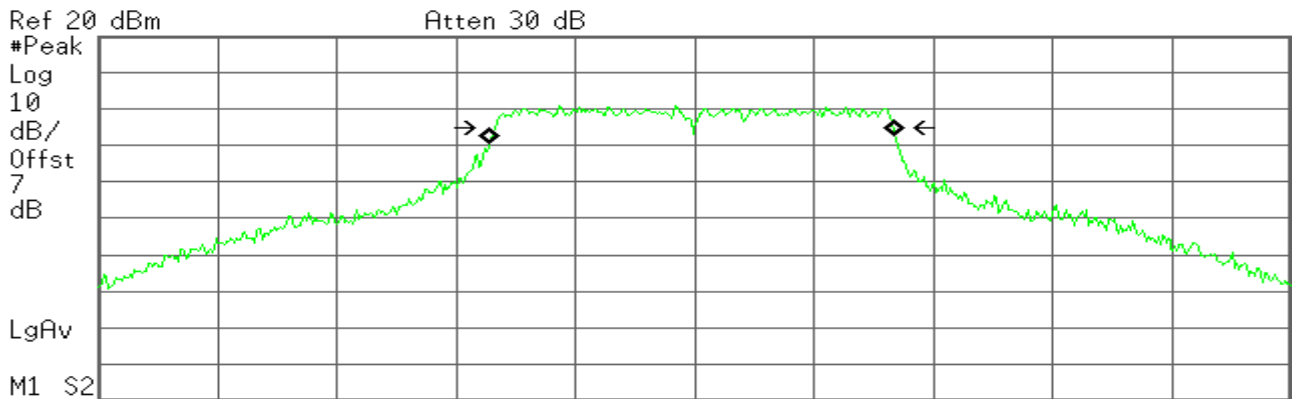

Ref 20 dBm Atten 30 dB  
 #Peak Log 10 dB/Offst 7 dB  
 M1 S2 Center 5.825 00 GHz Span 50 MHz  
 #Res BW 300 kHz #VBW 1 MHz Sweep 1 ms (601 pts)

**Occupied Bandwidth**  
**16.9053 MHz**

**Occ BW % Pwr** 99.00 %  
**x dB** -6.00 dB

**Transmit Freq Error** -100.282 kHz  
**x dB Bandwidth** 16.626 MHz

**IEEE 802.11n HT20 MODE/chain 0**

**99% Bandwidth (CH Low)**

Agilent

R T

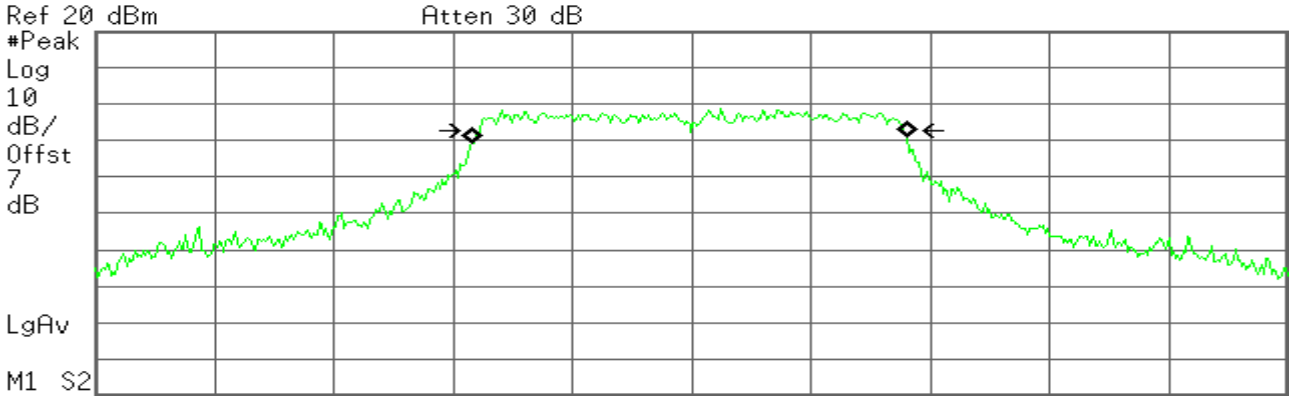

Center 5.745 00 GHz Span 50 MHz  
 #Res BW 300 kHz #VBW 1 MHz Sweep 1 ms (601 pts)

**Occupied Bandwidth**  
**18.1413 MHz**

**Occ BW % Pwr** 99.00 %  
**x dB** -6.00 dB

**Transmit Freq Error** -76.761 kHz  
**x dB Bandwidth** 17.685 MHz

**99% Bandwidth (CH Mid)**

Agilent

R T

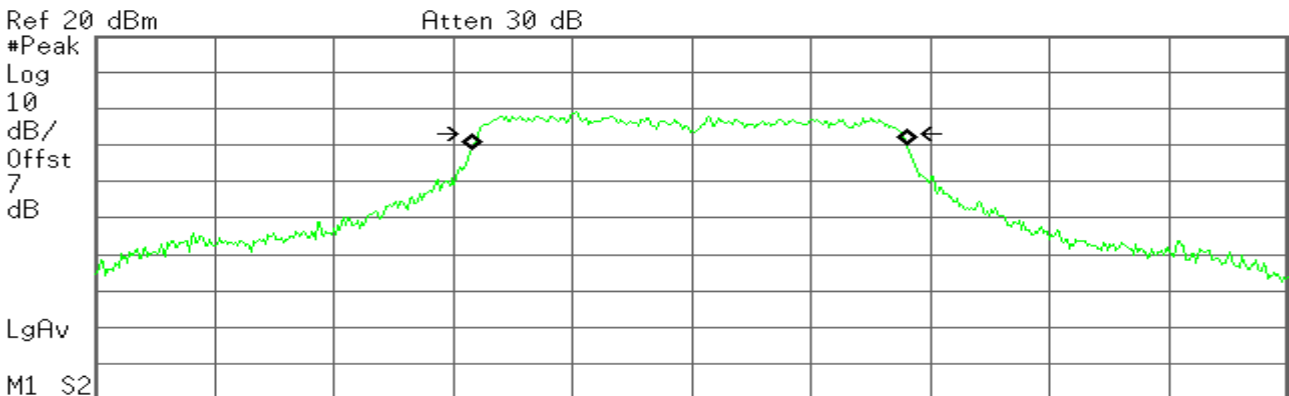

Center 5.785 00 GHz Span 50 MHz  
 #Res BW 300 kHz #VBW 1 MHz Sweep 1 ms (601 pts)

**Occupied Bandwidth**  
**18.1896 MHz**

**Occ BW % Pwr** 99.00 %  
**x dB** -6.00 dB

**Transmit Freq Error** -101.767 kHz  
**x dB Bandwidth** 17.673 MHz

**99% Bandwidth (CH High)**

Agilent

R T

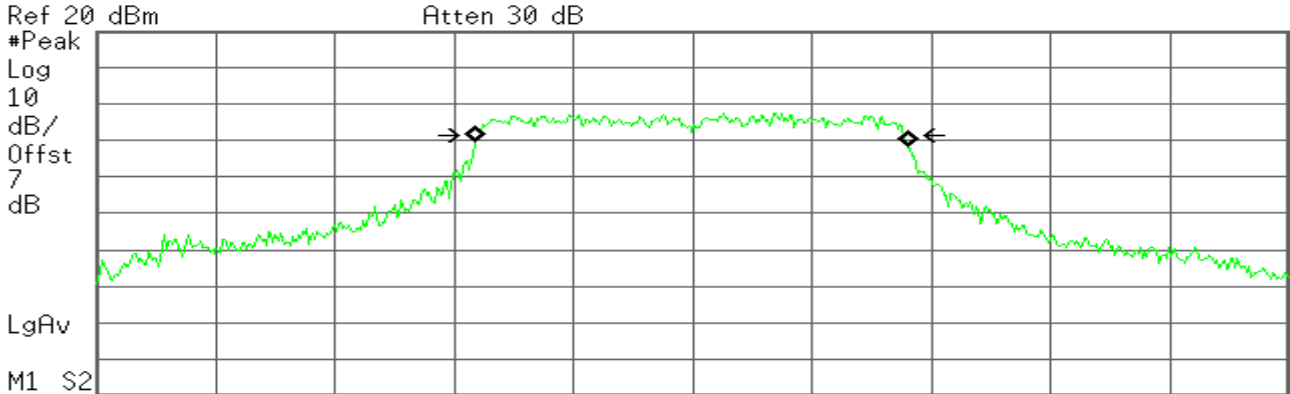

Ref 20 dBm Atten 30 dB  
 #Peak  
 Log  
 10  
 dB/  
 Offst  
 7  
 dB  
 LgAv  
 M1 S2  
 Center 5.825 00 GHz Span 50 MHz  
 #Res BW 300 kHz #VBW 1 MHz Sweep 1 ms (601 pts)

**Occupied Bandwidth**  
**18.0824 MHz**

**Occ BW % Pwr** 99.00 %  
**x dB** -6.00 dB

**Transmit Freq Error** -41.532 kHz  
**x dB Bandwidth** 17.694 MHz

**IEEE 802.11n HT20 MODE/chain 1**

**99% Bandwidth (CH Low)**

Agilent

R T

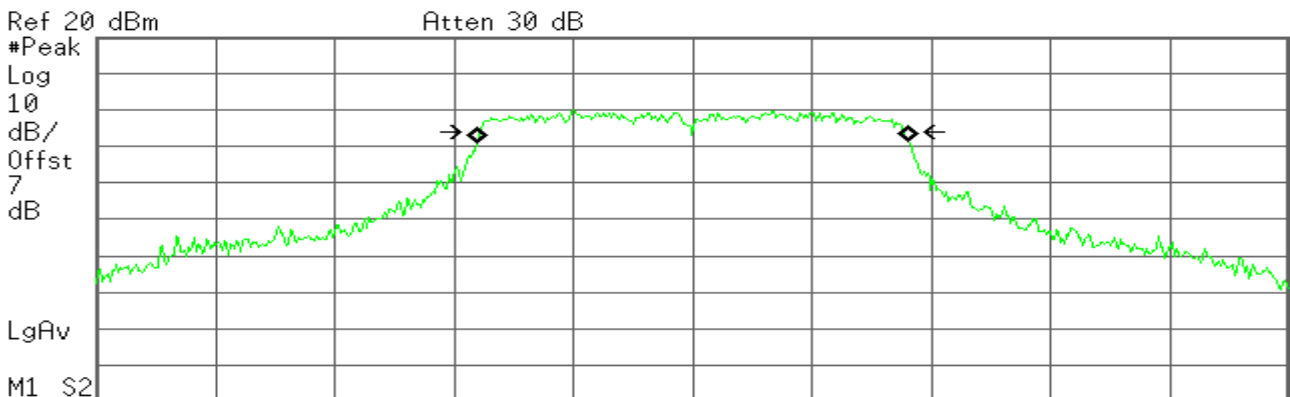

Ref 20 dBm Atten 30 dB  
 #Peak  
 Log  
 10  
 dB/  
 Offst  
 7  
 dB  
 LgAv  
 M1 S2  
 Center 5.745 00 GHz Span 50 MHz  
 #Res BW 300 kHz #VBW 1 MHz Sweep 1 ms (601 pts)

**Occupied Bandwidth**  
**18.0087 MHz**

**Occ BW % Pwr** 99.00 %  
**x dB** -6.00 dB

**Transmit Freq Error** -12.947 kHz  
**x dB Bandwidth** 17.688 MHz

**99% Bandwidth (CH Mid)**

Agilent

R T

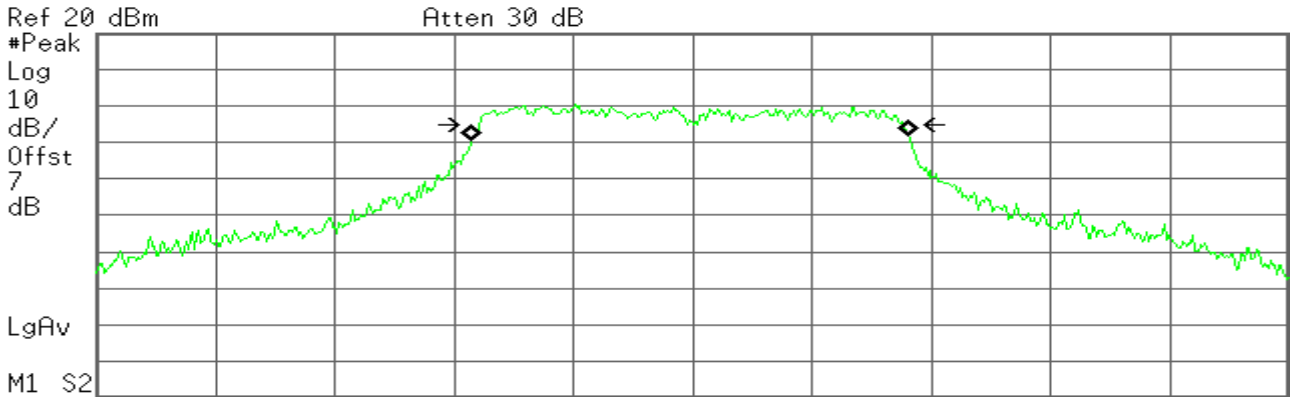

Center 5.785 00 GHz Span 50 MHz  
#Res BW 300 kHz #VBW 1 MHz Sweep 1 ms (601 pts)

**Occupied Bandwidth**  
**18.2491 MHz**

**Occ BW % Pwr** 99.00 %  
**x dB** -6.00 dB

**Transmit Freq Error** -105.859 kHz  
**x dB Bandwidth** 17.725 MHz

**99% Bandwidth (CH High)**

Agilent

R T

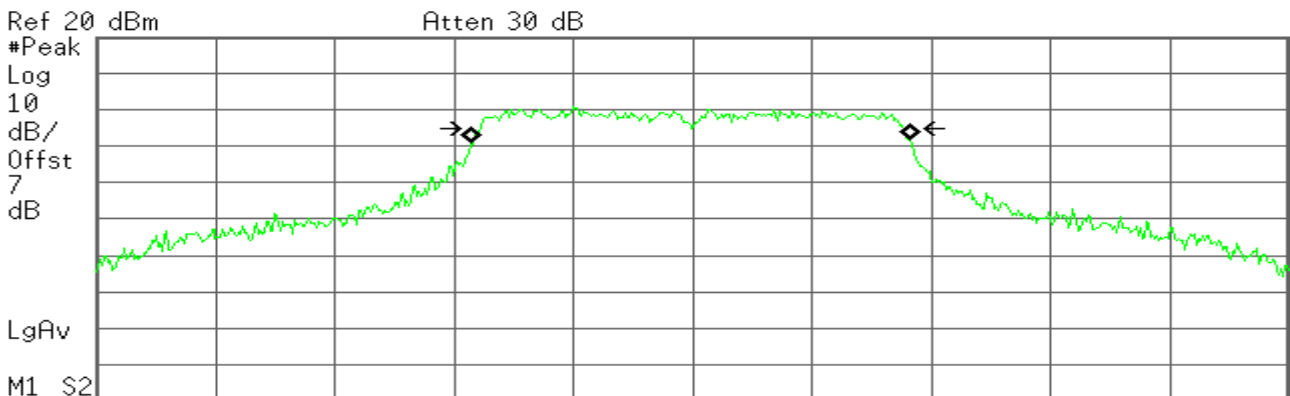

Center 5.825 00 GHz Span 50 MHz  
#Res BW 300 kHz #VBW 1 MHz Sweep 1 ms (601 pts)

**Occupied Bandwidth**  
**18.3037 MHz**

**Occ BW % Pwr** 99.00 %  
**x dB** -6.00 dB

**Transmit Freq Error** -76.685 kHz  
**x dB Bandwidth** 17.691 MHz

## 7.3 MAXIMUM CONDUCTED OUTPUT POWER

### LIMIT

According to §15.407(a),

For the band 5.725–5.85 GHz, the maximum conducted output power over the frequency band of operation shall not exceed 1 W.

*If transmitting antennas of directional gain greater than 6dBi are used, both the peak transmit power and the peak power spectral density shall be reduced by the amount in dB that the directional gain of the antenna exceeds 6dBi.*

The peak power shall not exceed the limit as follow:

### Test Configuration

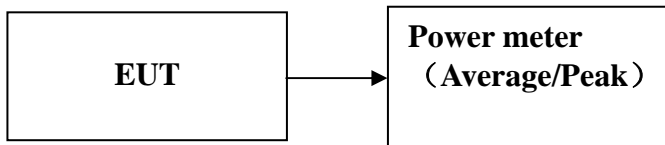

*The EUT was connected to a spectrum analyzer through a 50Ω RF cable.*

### TEST PROCEDURE

The testing follows Method PM of FCC KDB 789033 D02 General UNII Test Procedures New Rules v01.

Method PM (Measurement using an RF average power meter):

1. Measurement is performed using a wideband RF power meter.
2. The EUT is configured to transmit continuously with a consistent duty cycle at its maximum power control level.
3. Measure the average power of the transmitter, and the average power is corrected with duty factor,  $10 \log(1/x)$ , where x is the duty cycle.

### TEST RESULTS

*No non-compliance noted*

**Test Data**

**Test mode: IEEE 802.11a mode**

**5725~5850MHz**

Channel	Frequency (MHz)	Average Conducted Power (dBm)			Limit (dBm)
		Chain 0	Chain 1	Total Maximum Conducted Output Power	
Low	5745	8.34	7.34	10.88	30
Mid	5785	8.97	8.88	11.94	30
High	5825	10.30	10.20	13.26	30

**Test mode: IEEE 802.11n HT20 mode**

**5725~5850MHz**

Channel	Frequency (MHz)	Average Conducted Power (dBm)			Limit (dBm)
		Chain 0	Chain 1	Total Maximum Conducted Output Power	
Low	5745	8.16	7.99	11.09	30
Mid	5785	8.45	8.01	11.25	30
High	5825	8.32	8.21	11.28	30

**Note:**Duty factor has been offsetted with cableloss

**Remark:** Total Output Power (dBm) = 10\*LOG(10^(Chain 0 Output Power / 10)+10^(Chain 1 Output Power /10))



## 7.4 BAND EDGES MEASUREMENT

### LIMIT

According to §15.407(b),

(1) The provisions of Section 15.205 of this part apply to intentional radiators operating under this section.

(2) When measuring the emission limits, the nominal carrier frequency shall be adjusted as close to the upper and lower frequency block edges as the design of the equipment permits.

### Test Configuration

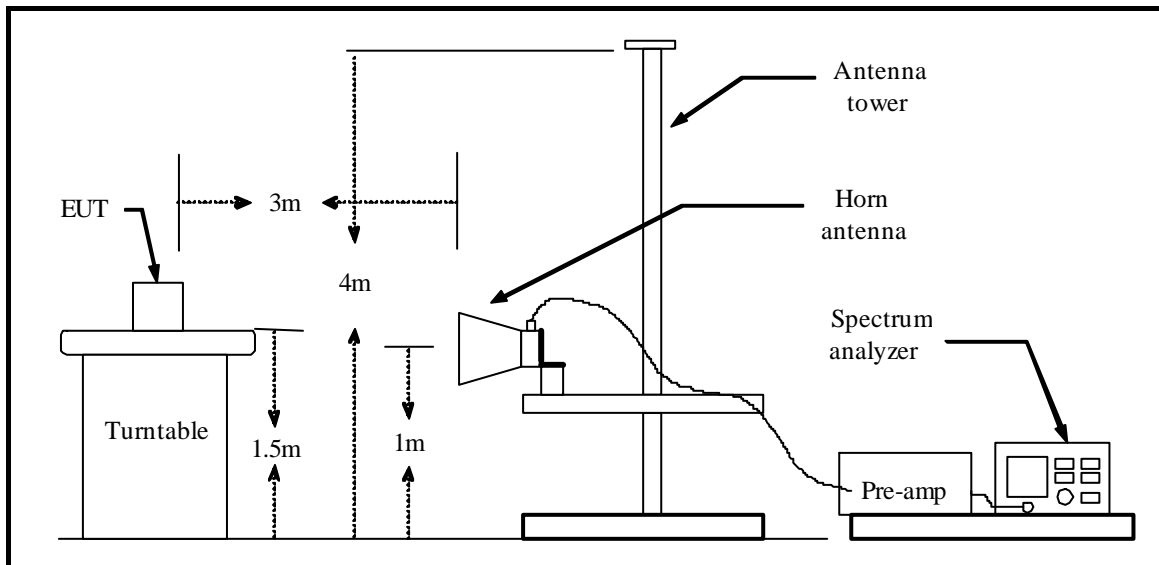

### TEST PROCEDURE

1. The EUT is placed on a turntable, which is 1.5m above the ground plane.
2. The turntable shall be rotated for 360 degrees to determine the position of maximum emission level.
3. EUT is set 3m away from the receiving antenna, which is varied from 1m to 4m to find out the highest emission.
4. Set the spectrum analyzer in the following setting in order to capture the lower and upper band-edges of the emission:
  - (a) PEAK: RBW=VBW=1MHz / Sweep=AUTO
  - (b) AVERAGE: RBW=1MHz / VBW=10Hz / Sweep=AUTO
5. Repeat the procedures until all the PEAK and AVERAGE versus POLARIZATION are measured.

### TEST RESULTS

Refer to attach spectrum analyzer data chart.

<b>Operation Mode:</b>	Tx / IEEE 802.11a mode CH/ Low	<b>Test Date:</b>	2015-12-26
<b>Temperature:</b>	25°C	<b>Tested by:</b>	Lily.Wang
<b>Humidity:</b>	55% RH	<b>Polarity:</b>	Ver. / Hor.

### Vertical

No.	Frequency (MHz)	Reading (dBuV)	Correct Factor(dB/m)	Result (dBuV/m)	Limit (dBuV/m)	Margin (dB)	Height (cm)	Degree (deg.)	Remark
1	5710.577	55.95	-0.78	55.17	68.20	-13.03	156	0	peak
2	5723.317	62.86	-0.76	62.10	78.20	-16.10	100	323	peak
3	N/A								

### Horizontal

No.	Frequency (MHz)	Reading (dBuV)	Correct Factor(dB/m)	Result (dBuV/m)	Limit (dBuV/m)	Margin (dB)	Height (cm)	Degree (deg.)	Remark
1	5709.615	55.82	-0.78	55.04	68.20	-13.16	100	275	peak
2	5723.798	62.78	-0.75	62.03	78.20	-16.17	100	324	peak
3	N/A								

<b>Operation Mode:</b>	Tx / IEEE 802.11a mode/ CH High	<b>Test Date:</b>	2015-12-26
<b>Temperature:</b>	25°C	<b>Tested by:</b>	Lily.Wang
<b>Humidity:</b>	55% RH	<b>Polarity:</b>	Ver. / Hor.

### Vertical

No.	Frequency (MHz)	Reading (dBuV)	Correct Factor(dB/m)	Result (dBuV/m)	Limit (dBuV/m)	Margin (dB)	Height (cm)	Degree (deg.)	Remark
1	5853.846	54.88	-0.52	54.36	78.20	-23.84	100	347	peak
2	5862.019	55.30	-0.51	54.79	68.20	-13.41	200	36	peak
3	N/A								

### Horizontal

No.	Frequency (MHz)	Reading (dBuV)	Correct Factor(dB/m)	Result (dBuV/m)	Limit (dBuV/m)	Margin (dB)	Height (cm)	Degree (deg.)	Remark
1	5850.000	55.39	-0.53	54.86	78.20	-23.34	201	327	peak
2	5860.417	55.76	-0.51	55.25	68.20	-12.95	100	58	peak
3	N/A								

<b>Operation Mode:</b>	Tx / IEEE 802.11n HT20 mode/ CH Low	<b>Test Date:</b>	2015-12-26
<b>Temperature:</b>	25°C	<b>Tested by:</b>	Lily.Wang
<b>Humidity:</b>	55% RH	<b>Polarity:</b>	Ver. / Hor.

### Vertical

No.	Frequency (MHz)	Reading (dBuV)	Correct Factor(dB/m)	Result (dBuV/m)	Limit (dBuV/m)	Margin (dB)	Height (cm)	Degree (deg.)	Remark
1	5710.697	56.02	-0.78	55.24	68.20	-12.96	100	325	peak
2	5723.077	64.80	-0.76	64.04	78.20	-14.16	100	25	peak
3	N/A								

### Horizontal

No.	Frequency (MHz)	Reading (dBuV)	Correct Factor(dB/m)	Result (dBuV/m)	Limit (dBuV/m)	Margin (dB)	Height (cm)	Degree (deg.)	Remark
1	5711.538	56.01	-0.78	55.23	68.20	-12.97	100	322	peak
2	5723.438	65.59	-0.76	64.83	78.20	-13.37	100	24	peak
3	N/A								

<b>Operation Mode:</b>	Tx / IEEE 802.11n HT20 mode/ CH High	<b>Test Date:</b>	2015-12-26
<b>Temperature:</b>	25°C	<b>Tested by:</b>	Lily.Wang
<b>Humidity:</b>	55% RH	<b>Polarity:</b>	Ver. / Hor.

### Vertical

No.	Frequency (MHz)	Reading (dBuV)	Correct Factor(dB/m)	Result (dBuV/m)	Limit (dBuV/m)	Margin (dB)	Height (cm)	Degree (deg.)	Remark
1	5850.160	58.38	-0.53	57.85	78.20	-20.35	100	19	peak
2	5860.897	55.67	-0.51	55.16	68.20	-13.04	100	297	peak
3	N/A								

### Horizontal

No.	Frequency (MHz)	Reading (dBuV)	Correct Factor(dB/m)	Result (dBuV/m)	Limit (dBuV/m)	Margin (dB)	Height (cm)	Degree (deg.)	Remark
1	5850.160	57.50	-0.53	56.97	78.20	-21.23	100	19	peak
2	5860.577	55.15	-0.51	54.64	68.20	-13.56	100	240	peak
3	N/A								

## 7.5 POWER SPECTRAL DENSITY

### LIMIT

According to §15.407(a),

For the band 5.725–5.85 GHz, the maximum power spectral density shall not exceed 30 dBm in any 500-kHz band.

*If transmitting antennas of directional gain greater than 6dBi are used, both the maximum transmit power and the maximum power spectral density shall be reduced by the amount in dB that the directional gain of the antenna exceeds 6dBi.*

### Test Configuration

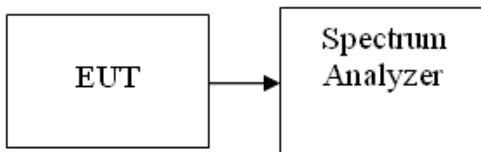

### TEST PROCEDURE

1. The testing follows Method SA-2 of FCC KDB 789033 D01 General UNII Test Procedures v01r03.
2. Measure the duty cycle, Set span to encompass the entire emission bandwidth (EBW) of the signal. Set RBW = 300 kHz. Set VBW  $\geq$  1 MHz. Number of points in sweep  $\geq$  2 Span / RBW. Sweep time = auto. Detector = RMS, Trace average at least 100 traces in power averaging mode. Add  $10 \log(500\text{kHz}/\text{RBW})$  to the test result. Add  $10 \log(1/x)$ , where x is the duty cycle, to the measured power in order to compute the average power during the actual transmission times. For example, add  $10 \log(1/0.25) = 6$  dB if the duty cycle is 25 percent.
3. The RF output of EUT was connected to the spectrum analyzer by a low loss cable.
4. Each plot has already offset with cable loss, and attenuator loss. Measure the PPSD and record it.
5. For MIMO mode, calculation method follows FCC KDB 662911 D01 Multiple Transmitter Output v02r01.

Method (1): Measure and sum the spectra across the outputs. The total final Power Spectral Density is from a device with 2 transmitter outputs. The spectrum measurements of the individual outputs are all performed with the same span and number of points, the spectrum value in the first spectral bin of output 1 is summed with that in the first spectral bin of output 2 to obtain the value for the first frequency bin of the summed spectrum.

### TEST RESULTS

*No non-compliance noted*

**Test Data**

Test mode: IEEE 802.11a mode

**5725~5850MHz**

Channel	Frequency (MHz)	Average PSD (dBm/300kHz)		10log (500kHz/RBW) Factor (dB)	Average PSD (dBm/500kHz)		Total Average PSD (dBm/500kHz)	Average PSD Limit (dBm/500kHz)	Result
		Chain 0	Chain 1		Chain 0	Chain 1			
Low	5745	-0.19	1.01	2.22	2.03	3.23	5.68	30.00	PASS
Mid	5785	-1.36	1.38	2.22	0.86	3.60	5.45	30.00	PASS
High	5825	-1.62	1.30	2.22	0.60	3.52	5.31	30.00	PASS

Test mode: IEEE 802.11n HT20 mode

**5725~5850MHz**

Channel	Frequency (MHz)	Average PSD (dBm/300kHz)		10log (500kHz/RBW) Factor (dB)	Average PSD (dBm/500kHz)		Total Average PSD (dBm/500kHz)	Average PSD Limit (dBm/500kHz)	Result
		Chain 0	Chain 1		Chain 0	Chain 1			
Low	5745	-0.82	-0.45	2.22	1.40	1.77	4.60	30.00	PASS
Mid	5785	-1.76	-0.13	2.22	0.46	2.09	4.36	30.00	PASS
High	5825	-2.24	1.31	2.22	-0.02	3.53	5.12	30.00	PASS

**Note:**Duty factor has been offsetted with cableloss

**Remark:** Total PPSD (dBm) = 10\*LOG(10^(Chain 0 PPSD / 10)+10^(Chain 1 PPSD / 10))

**Test Plot**

**IEEE 802.11a mode/chain 0**

**5725~5850MHz**

**CH Low**

**Agilent**

**R T**

Mkr1 5.751 00 GHz  
-0.19 dBm

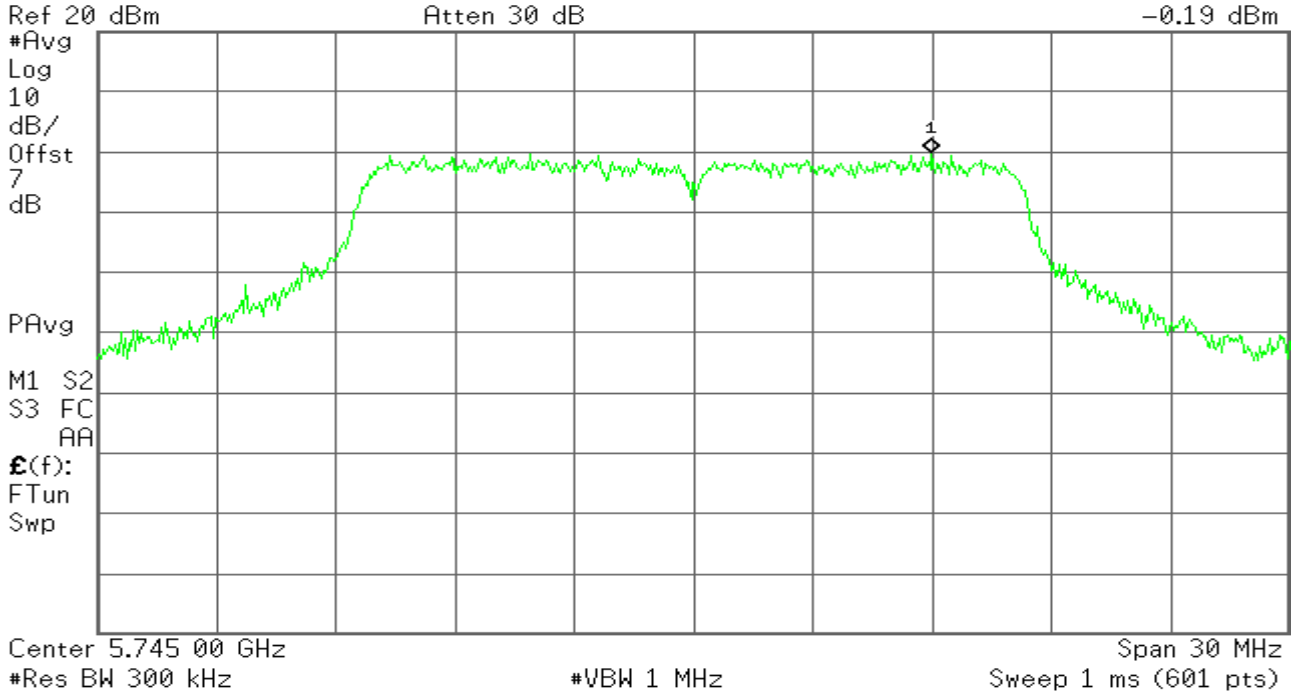

**CH Mid**

**Agilent**

**R T**

Mkr1 5.777 60 GHz  
-1.36 dBm

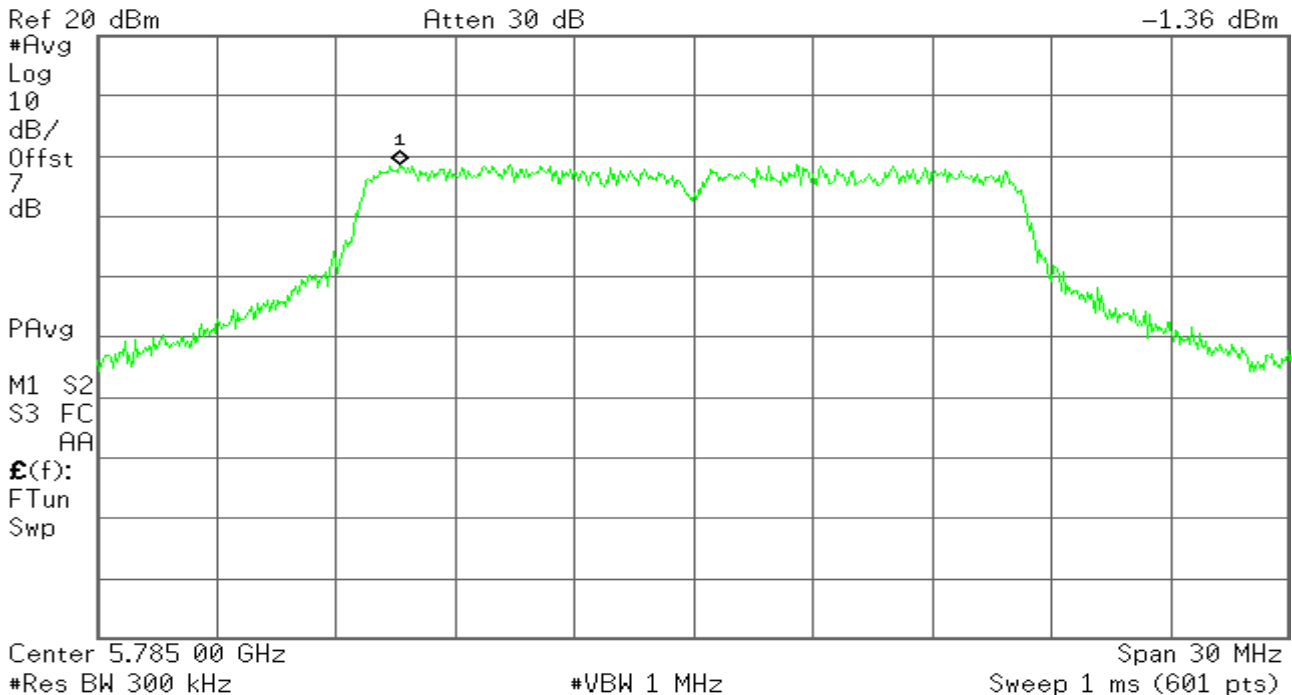

**CH High**

Agilent

R T

Mkr1 5.817 85 GHz  
-1.62 dBm

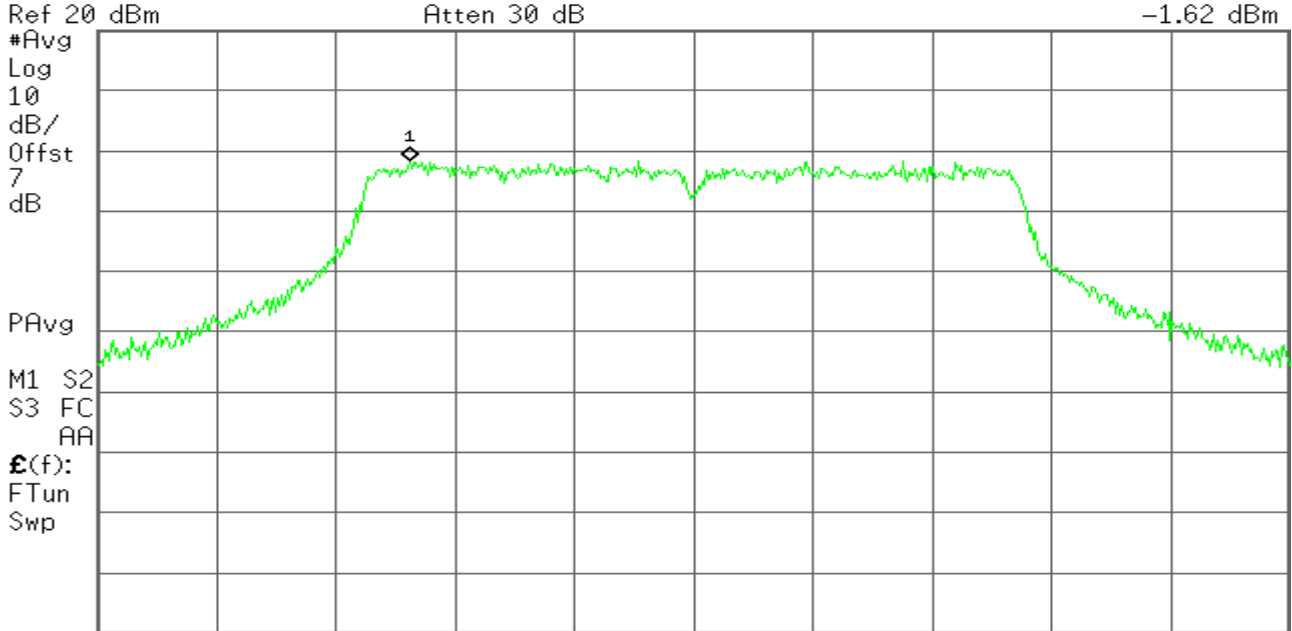

Center 5.825 00 GHz

Span 30 MHz

#Res BW 300 kHz

#VBW 1 MHz

Sweep 1 ms (601 pts)

**IEEE 802.11n mode/chain 1  
5725~5850MHz**

**CH Low**

Agilent

R T

Mkr1 5.742 35 GHz  
1.01 dBm

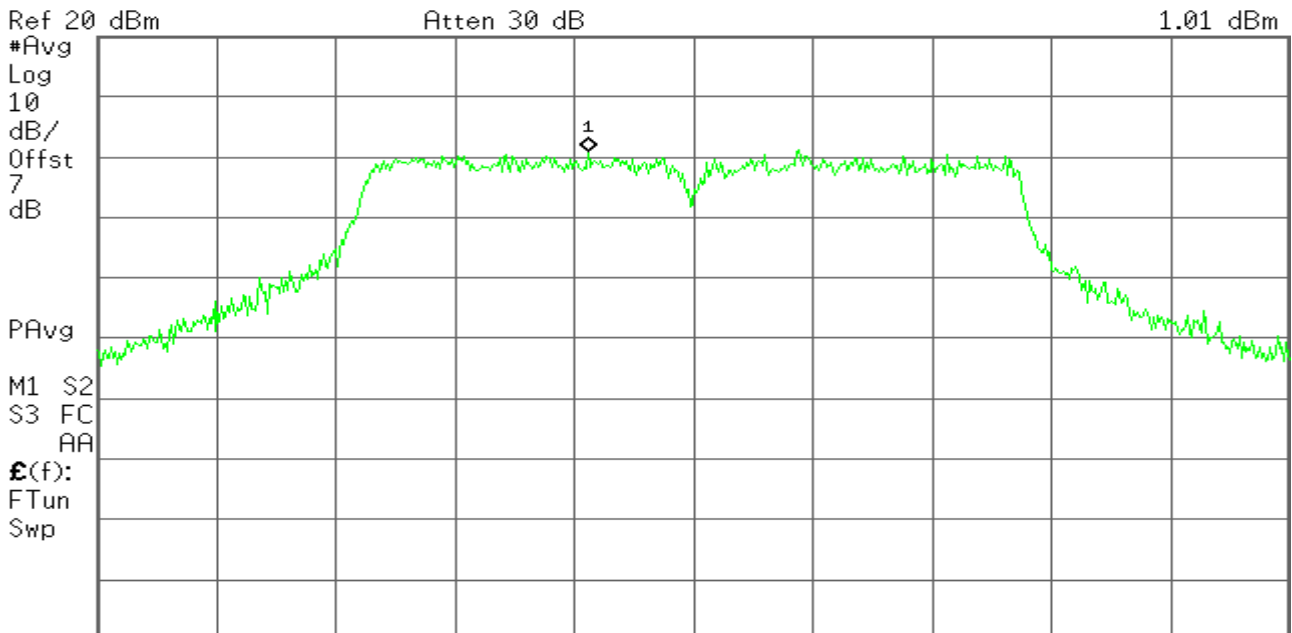

Center 5.745 00 GHz

Span 30 MHz

#Res BW 300 kHz

#VBW 1 MHz

Sweep 1 ms (601 pts)

**CH Mid**

Agilent

R T

Mkr1 5.780 40 GHz  
1.38 dBm

Ref 20 dBm

Atten 30 dB

#Avg  
Log  
10  
dB/  
Offst  
7  
dB

PAvg

M1 S2  
S3 FC  
AA

£(f):  
FTun  
Swp

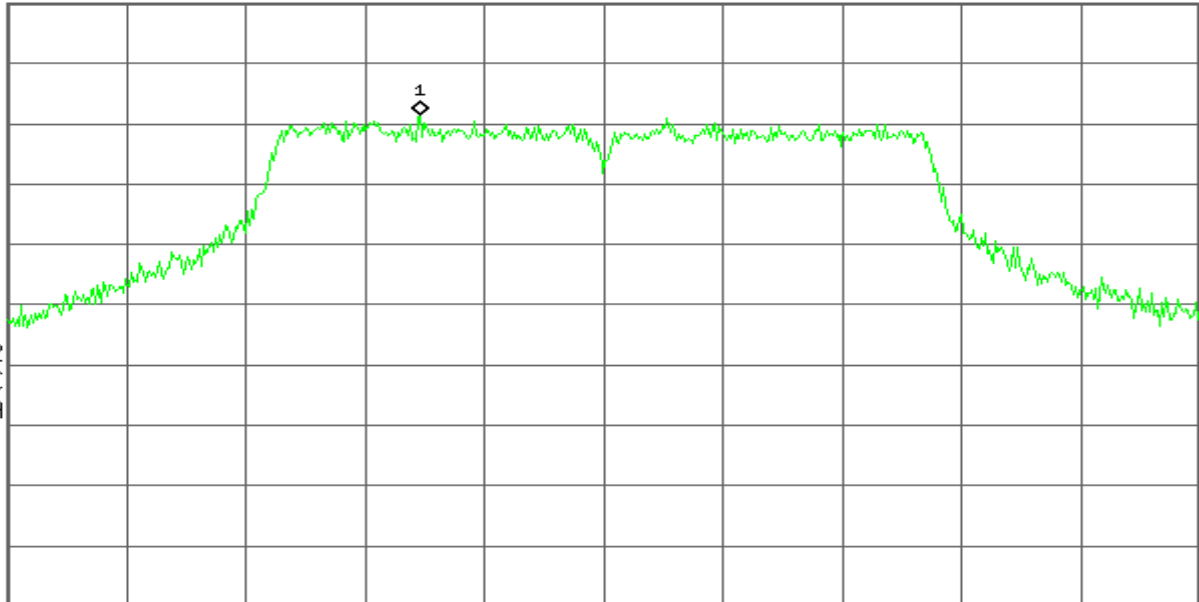

Center 5.785 00 GHz

Span 30 MHz

#Res BW 300 kHz

#VBW 1 MHz

Sweep 1 ms (601 pts)

**CH High**

Agilent

R T

Mkr1 5.820 30 GHz  
1.30 dBm

Ref 20 dBm

Atten 30 dB

#Avg  
Log  
10  
dB/  
Offst  
7  
dB

PAvg

M1 S2  
S3 FC  
AA

£(f):  
FTun  
Swp

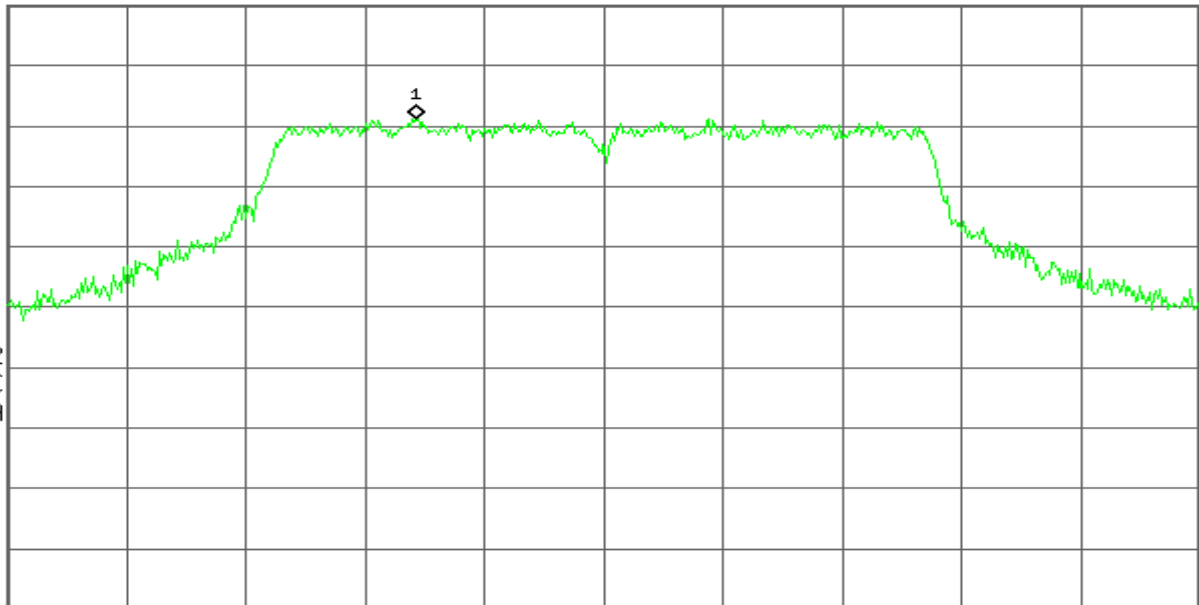

Center 5.825 00 GHz

Span 30 MHz

#Res BW 300 kHz

#VBW 1 MHz

Sweep 1 ms (601 pts)



**IEEE 802.11n HT20 mode/chain 0**  
**5725~5850MHz**

**CH Low**

Agilent

R T

Mkr1 5.740 15 GHz  
 -0.82 dBm

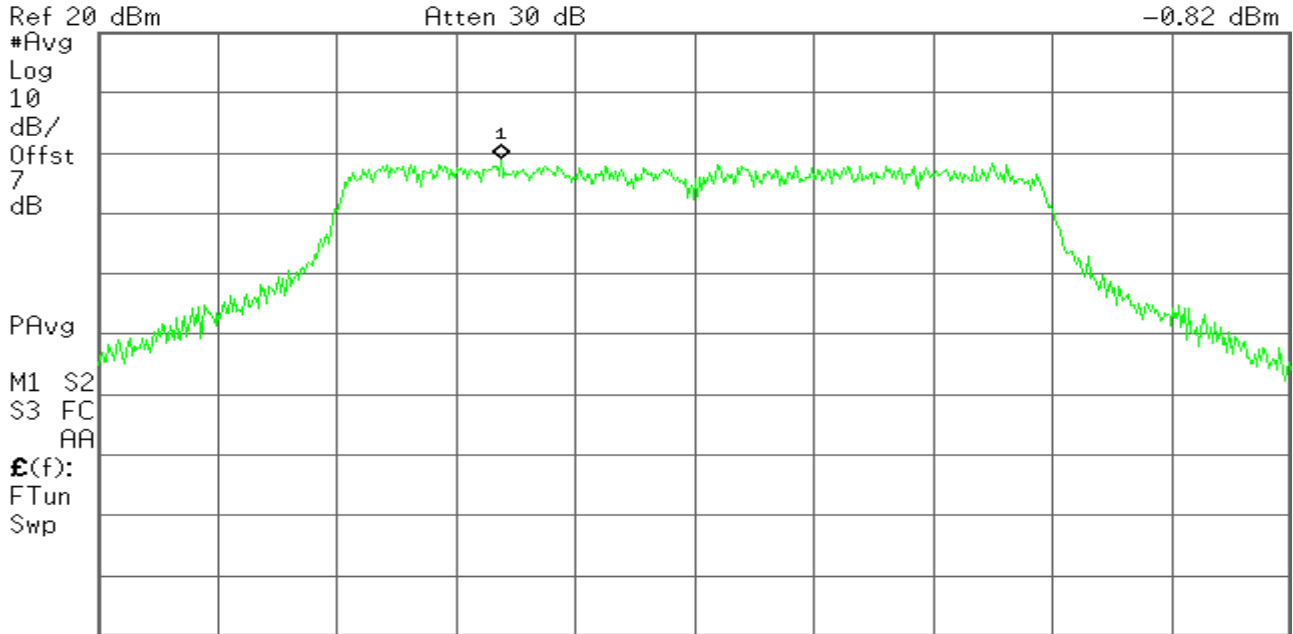

Center 5.745 00 GHz  
 #Res BW 300 kHz  
 #VBW 1 MHz  
 Span 30 MHz  
 Sweep 1 ms (601 pts)

**CH Mid**

Agilent

R T

Mkr1 5.781 25 GHz  
 -1.76 dBm

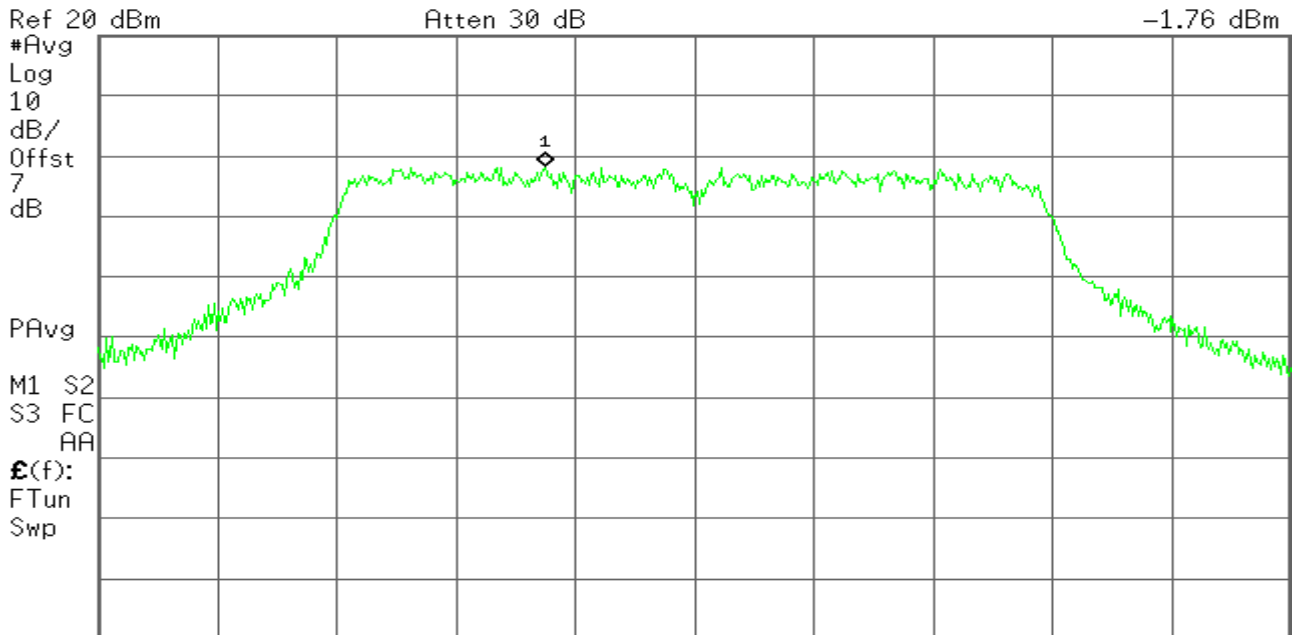

Center 5.785 00 GHz  
 #Res BW 300 kHz  
 #VBW 1 MHz  
 Span 30 MHz  
 Sweep 1 ms (601 pts)

**CH High**

Agilent

R T

Mkr1 5.821 20 GHz  
-2.24 dBm

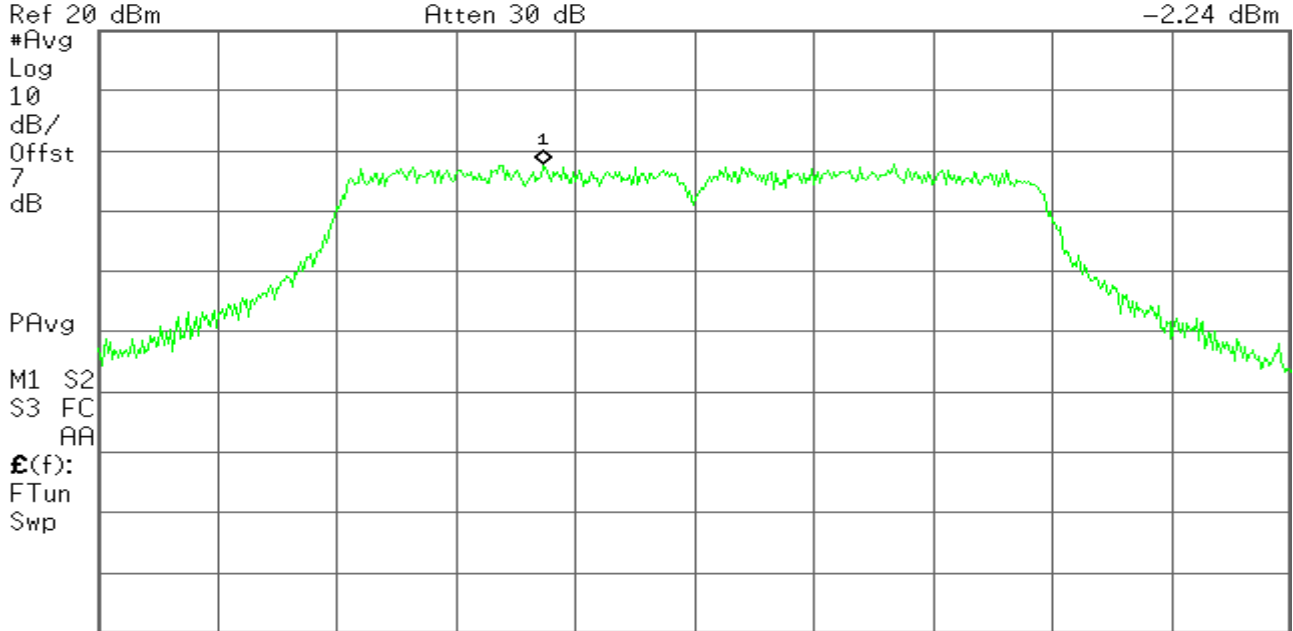

Center 5.825 00 GHz

Span 30 MHz

#Res BW 300 kHz

#VBW 1 MHz

Sweep 1 ms (601 pts)

**IEEE 802.11a HT20 mode/chain 1  
5725~5850MHz**

**CH Low**

Agilent

R T

Mkr1 5.737 00 GHz  
-0.45 dBm

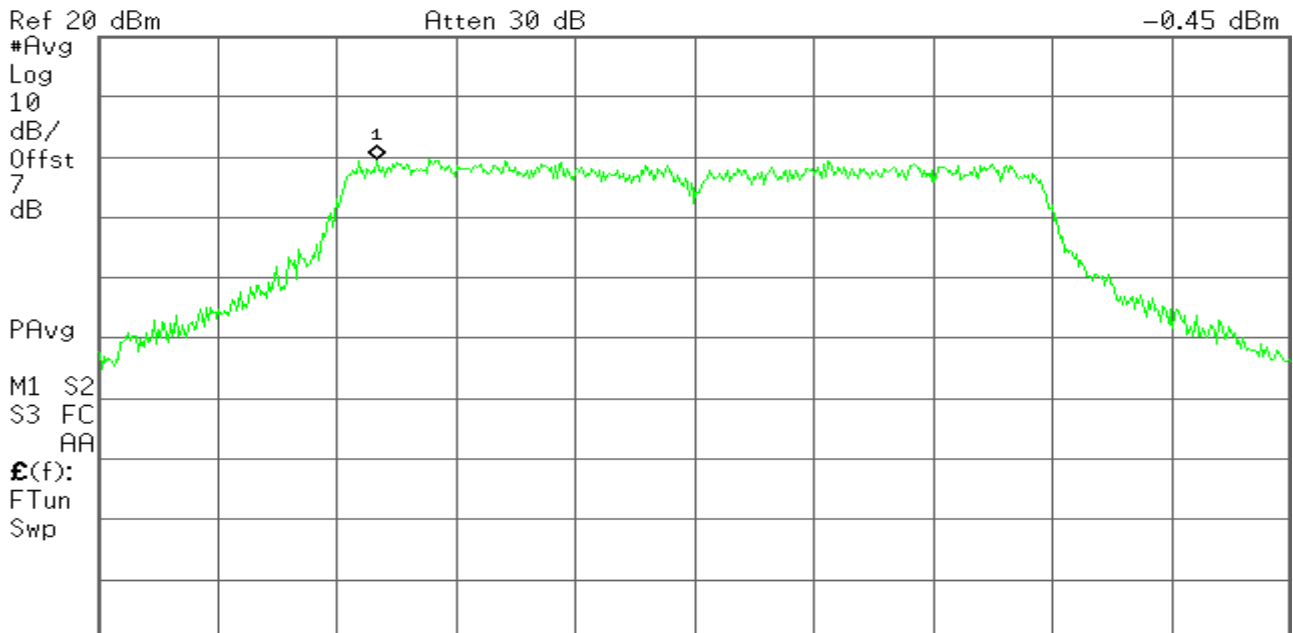

Center 5.745 00 GHz

Span 30 MHz

#Res BW 300 kHz

#VBW 1 MHz

Sweep 1 ms (601 pts)

**CH Mid**

Agilent

R T

Mkr1 5.777 10 GHz  
-0.13 dBm

Ref 20 dBm

Atten 30 dB

#Avg  
Log  
10  
dB/  
Offst  
7  
dB

PAvg

M1 S2  
S3 FC  
AA

£(f):  
FTun  
Swp

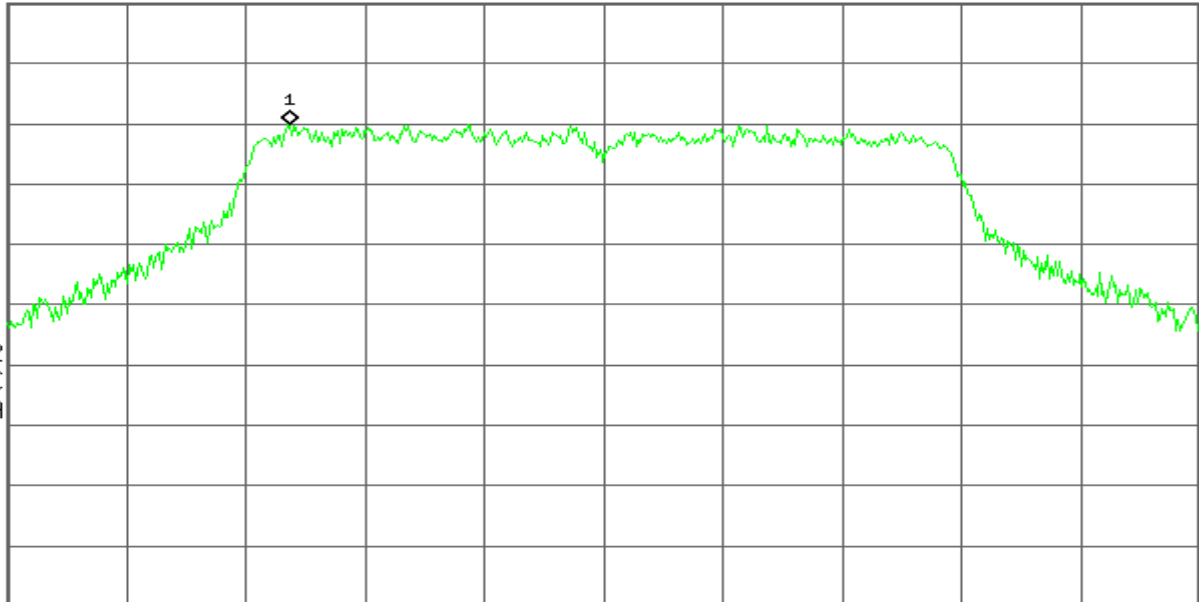

Center 5.785 00 GHz

Span 30 MHz

#Res BW 300 kHz

#VBW 1 MHz

Sweep 1 ms (601 pts)

**CH High**

Agilent

R T

Mkr1 5.820 10 GHz  
1.31 dBm

Ref 20 dBm

Atten 30 dB

#Avg  
Log  
10  
dB/  
Offst  
7  
dB

PAvg

M1 S2  
S3 FC  
AA

£(f):  
FTun  
Swp

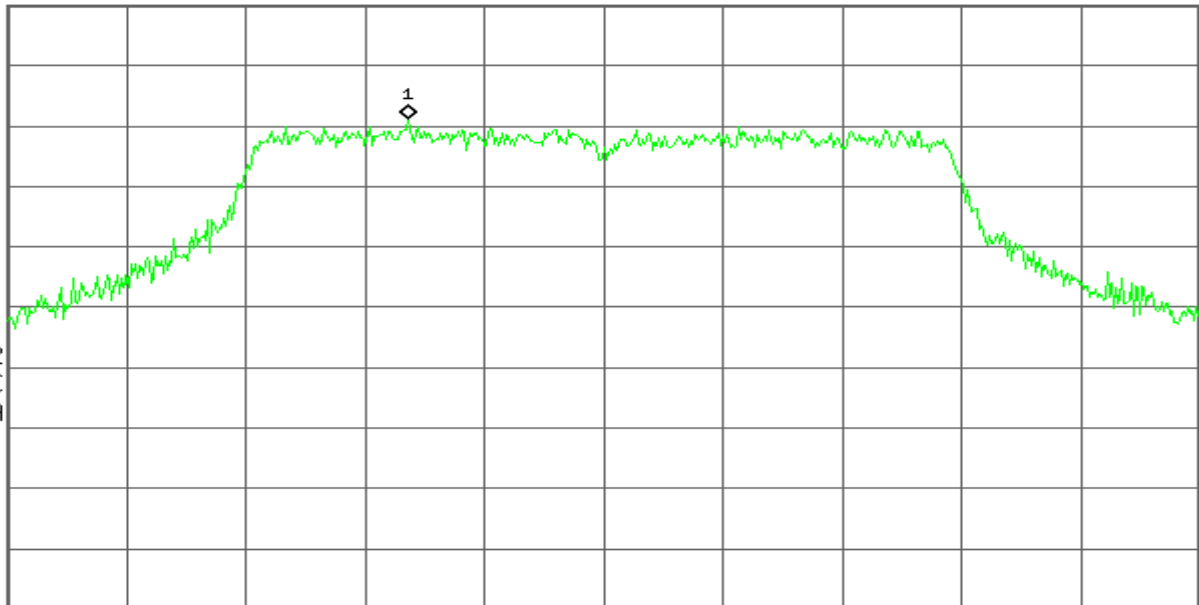

Center 5.825 00 GHz

Span 30 MHz

#Res BW 300 kHz

#VBW 1 MHz

Sweep 1 ms (601 pts)

## 7.6 RADIATED UNDESIRABLE EMISSION

### LIMIT

Radiated emissions from 9 kHz to 25 GHz were measured according to the methods defines in ANSI C63.10-2013. The EUT was placed above the ground plane, 0.8 meter for frequency below 1GHz and 1.5 meter for frequency above 1GHz. The interface cables and equipment positions were varied within limits of reasonable applications to determine the positions producing maximum radiated emissions

1. According to §15.209(a), except as provided elsewhere in this Subpart, the emissions from an intentional radiator shall not exceed the field strength levels specified in the following table:

FREQUENCIES(MHz)	FIELD STRENGTH (microvolts/meter)	MEASUREMENT DISTANCE(meters)
0.009~0.490	2400/F(kHz)	300
0.490~1.705	24000/F(kHz)	30
1.705~30.0	30	30
30~88	100	3
88~216	150	3
216~960	200	3
Above 960	500	3

**Remark:** Except as provided in paragraph (g), fundamental emissions from intentional radiators operating under this Section shall not be located in the frequency bands 54-72 MHz, 76-88 MHz, 174-216 MHz or 470-806 MHz. However, operation within these frequency bands is permitted under other sections of this Part, e.g., Sections 15.231 and 15.241.

2. In the emission table above, the tighter limit applies at the band edges.

Frequency (MHz)	Field Strength ( $\mu$ V/m at 3-meter)	Field Strength (dB $\mu$ V/m at 3-meter)
30-88	100	40
88-216	150	43.5
216-960	200	46
Above 960	500	54

### Test Configuration

**Below 30MHz**

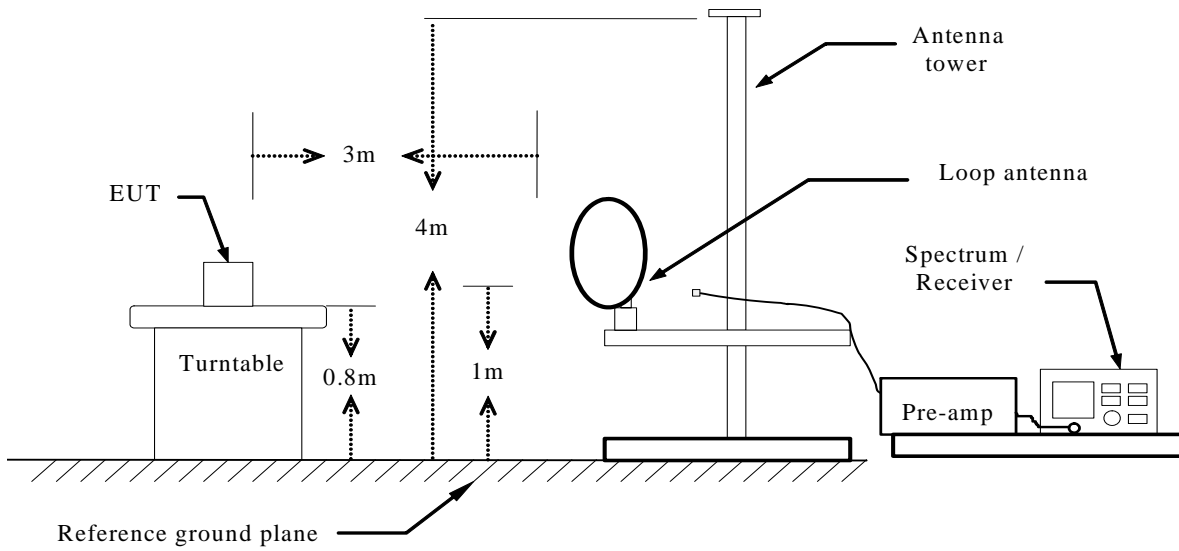

**Below 1 GHz**

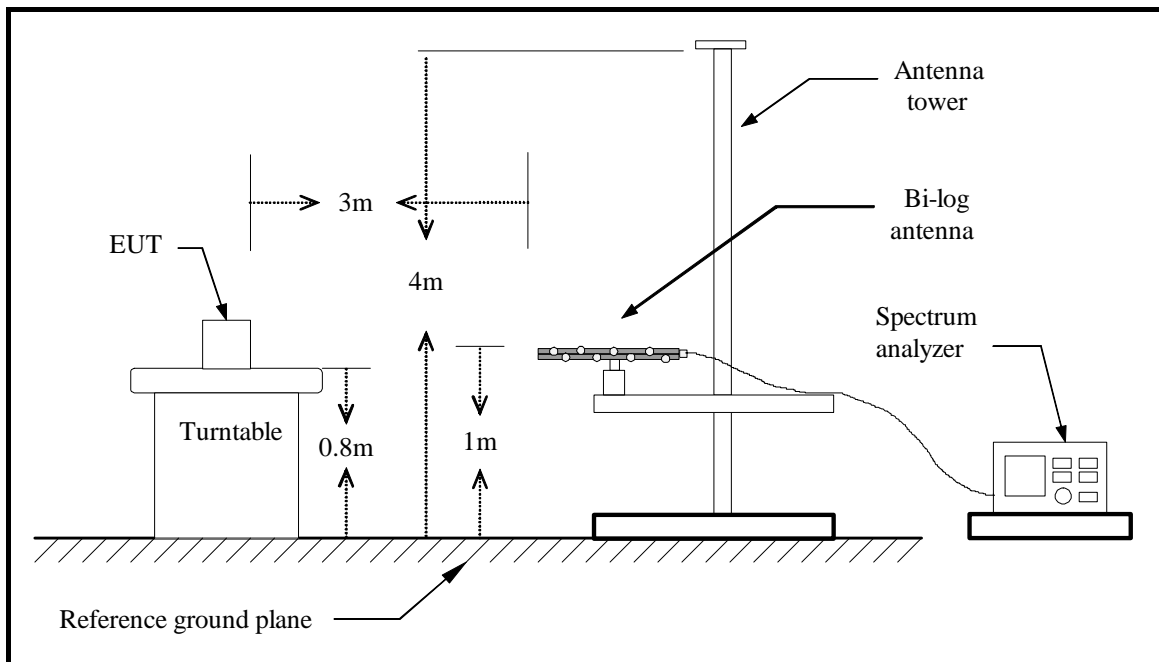

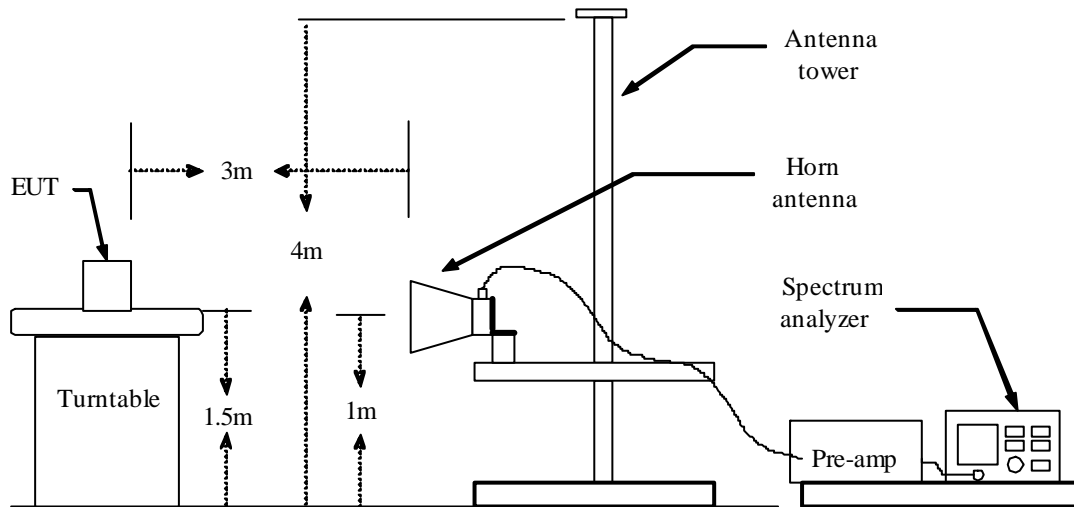
**Above 1 GHz****TEST PROCEDURE**

1. The EUT is placed on a turntable above ground plane, which is 0.8 meter for frequency below 1GHz and 1.5 meter for frequency above 1GHz.
2. The turntable shall be rotated for 360 degrees to determine the position of maximum emission level.
3. EUT is set 3m away from the receiving antenna, which is varied from 1m to 4m to find out the highest emissions.
4. Maximum procedure was performed on the six highest emissions to ensure EUT compliance.
5. And also, each emission was to be maximized by changing the polarization of receiving antenna both horizontal and vertical.
6. Set the spectrum analyzer in the following setting as:

Below 1GHz:

RBW=100kHz / VBW=300kHz / Sweep=AUTO

Above 1GHz:

(a) PEAK: RBW=VBW=1MHz / Sweep=AUTO

(b) AVERAGE: RBW=1MHz / VBW=10Hz / Sweep=AUTO

7. Repeat above procedures until the measurements for all frequencies are complete.

## TEST RESULTS

### Below 1 GHz

<b>Operation Mode:</b>	Normal Link	<b>Test Date:</b>	2015-12-27
<b>Temperature:</b>	25°C	<b>Tested by:</b>	Lily.Wang
<b>Humidity:</b>	48% RH	<b>Polarity:</b>	Ver. / Hor.

Frequency (MHz)	Ant. Pol. (H/V)	Reading (dBuV)	Correction Factor (dB/m)	Result (dBuV/m)	Limit (dBuV/m)	Margin (dB)	Remark
38.7300	V	16.60	17.25	33.85	40.00	-6.15	peak
111.4800	V	25.33	12.05	37.38	43.50	-6.12	peak
154.1600	V	24.42	11.59	36.01	43.50	-7.49	peak
308.3900	V	21.45	14.59	36.04	46.00	-9.96	peak
720.6400	V	14.85	22.79	37.64	46.00	-8.36	peak
996.1200	V	15.93	24.96	40.89	54.00	-13.11	peak
37.7600	H	15.23	17.43	32.66	40.00	-7.34	peak
87.2300	H	24.79	10.71	35.50	40.00	-4.50	peak
308.3900	H	20.53	14.59	35.12	46.00	-10.88	peak
720.6400	H	18.44	22.79	41.23	46.00	-4.77	peak
832.1900	H	15.42	23.25	38.67	46.00	-7.33	peak
993.2100	H	16.14	24.95	41.09	54.00	-12.91	peak

**Remark:**

1. Measuring frequencies from 30 MHz to the 1GHz.(no emission found from the lowest internal used/generated frequency to 30MHz)
2. Radiated emissions measured were made with an instrument using peak/quasi-peak detector mode.
3. Quasi-peak test would be performed if the peak result were greater than the quasi-peak limit or as required by the applicant.
4. Measurements above show only up to 6 maximum emissions noted, or would be lesser, with " N/A " remark, if no specific emissions from the EUT are recorded (ie: margin>20dB from the applicable limit) and considered that's already beyond the background noise floor.
5. Margin (dB) = Remark result (dBuV/m) – Quasi-peak limit (dBuV/m).

### Above 1 GHz

<b>Operation Mode:</b>	Tx / IEEE 802.11a mode CH Low	<b>Test Date:</b>	2015-9-7
<b>Temperature:</b>	25°C	<b>Tested by:</b>	Lily.Wang
<b>Humidity:</b>	55% RH	<b>Polarity:</b>	Ver. / Hor.

#### Horizontal

No.	Frequency (MHz)	Reading (dBuV)	Correct Factor(dB/m)	Result (dBuV/m)	Limit (dBuV/m)	Margin (dB)	Height (cm)	Degree (deg.)	Remark
1	11052.885	39.63	4.36	43.99	74.00	-30.01	100	60	peak
2	15439.103	37.52	3.14	40.66	74.00	-33.34	100	3	peak
3	N/A								
4									
5									
6									

#### Vertical

No.	Frequency (MHz)	Reading (dBuV)	Correct Factor(dB/m)	Result (dBuV/m)	Limit (dBuV/m)	Margin (dB)	Height (cm)	Degree (deg.)	Remark
1	11216.346	39.83	4.15	43.98	74.00	-30.02	100	75	peak
2	15330.128	36.38	3.66	40.04	74.00	-33.96	100	243	peak
3	N/A								
4									
5									
6									

<b>Operation Mode:</b>	Tx / IEEE 802.11a mode CH Mid	<b>Test Date:</b>	2015-9-7
<b>Temperature:</b>	25°C	<b>Tested by:</b>	Lily.Wang
<b>Humidity:</b>	55% RH	<b>Polarity:</b>	Ver. / Hor.

#### Horizontal

No.	Frequency (MHz)	Reading (dBuV)	Correct Factor(dB/m)	Result (dBuV/m)	Limit (dBuV/m)	Margin (dB)	Height (cm)	Degree (deg.)	Remark
1	11570.513	38.93	3.68	42.61	74.00	-31.39	100	258	peak
2	15330.128	36.43	3.66	40.09	74.00	-33.91	100	200	peak
3	N/A								
4									
5									
6									

#### Vertical

No.	Frequency (MHz)	Reading (dBuV)	Correct Factor(dB/m)	Result (dBuV/m)	Limit (dBuV/m)	Margin (dB)	Height (cm)	Degree (deg.)	Remark
1	11570.513	39.25	3.68	42.93	74.00	-31.07	100	311	peak
2	15221.154	36.41	4.18	40.59	74.00	-33.41	100	99	peak
3	N/A								
4									
5									
6									



<b>Operation Mode:</b>	Tx / IEEE 802.11a mode CH High	<b>Test Date:</b>	2015-9-7
<b>Temperature:</b>	25°C	<b>Tested by:</b>	Lily.Wang
<b>Humidity:</b>	55% RH	<b>Polarity:</b>	Ver. / Hor.

### Horizontal

No.	Frequency (MHz)	Reading (dBuV)	Correct Factor(dB/m)	Result (dBuV/m)	Limit (dBuV/m)	Margin (dB)	Height (cm)	Degree (deg.)	Remark
1	11216.346	39.33	4.15	43.48	74.00	-30.52	100	148	peak
2	15439.103	37.55	3.14	40.69	74.00	-33.31	100	256	peak
3	N/A								
4									
5									
6									

### Vertical

No.	Frequency (MHz)	Reading (dBuV)	Correct Factor(dB/m)	Result (dBuV/m)	Limit (dBuV/m)	Margin (dB)	Height (cm)	Degree (deg.)	Remark
1	11270.833	39.04	4.08	43.12	74.00	-30.88	100	215	peak
2	15439.103	36.84	3.14	39.98	74.00	-34.02	100	82	peak
3	N/A								
4									
5									
6									

<b>Operation Mode:</b>	TX / IEEE 802.11n HT20 mode /CH Low	<b>Test Date:</b>	2015-9-7
<b>Temperature:</b>	25°C	<b>Tested by:</b>	Lily.Wang
<b>Humidity:</b>	55% RH	<b>Polarity:</b>	Ver. / Hor.

### Horizontal

No.	Frequency (MHz)	Reading (dBuV)	Correct Factor(dB/m)	Result (dBuV/m)	Limit (dBuV/m)	Margin (dB)	Height (cm)	Degree (deg.)	Remark
1	11298.077	39.45	4.04	43.49	74.00	-30.51	100	318	peak
2	15466.346	36.56	3.01	39.57	74.00	-34.43	100	19	peak
3	N/A								
4									
5									
6									

### Vertical

No.	Frequency (MHz)	Reading (dBuV)	Correct Factor(dB/m)	Result (dBuV/m)	Limit (dBuV/m)	Margin (dB)	Height (cm)	Degree (deg.)	Remark
1	10943.910	38.75	4.52	43.27	74.00	-30.73	100	216	peak
2	15357.372	36.34	3.53	39.87	74.00	-34.13	100	259	peak
3	N/A								
4									
5									
6									

<b>Operation Mode:</b>	TX / IEEE 802.11n HT20 mode /CH Mid	<b>Test Date:</b>	2015-9-7
<b>Temperature:</b>	25°C	<b>Tested by:</b>	Lily.Wang
<b>Humidity:</b>	55% RH	<b>Polarity:</b>	Ver. / Hor.

### Horizontal

No.	Frequency (MHz)	Reading (dBuV)	Correct Factor(dB/m)	Result (dBuV/m)	Limit (dBuV/m)	Margin (dB)	Height (cm)	Degree (deg.)	Remark
1	11325.320	39.87	4.00	43.87	74.00	-30.13	100	28	peak
2	15520.833	37.83	2.75	40.58	74.00	-33.42	100	265	peak
3	N/A								
4									
5									
6									

### Vertical

No.	Frequency (MHz)	Reading (dBuV)	Correct Factor(dB/m)	Result (dBuV/m)	Limit (dBuV/m)	Margin (dB)	Height (cm)	Degree (deg.)	Remark
1	11407.051	38.62	3.90	42.52	74.00	-31.48	100	259	peak
2	15466.346	36.76	3.01	39.77	74.00	-34.23	100	95	peak
3	N/A								
4									
5									
6									

<b>Operation Mode:</b>	TX / IEEE 802.11n HT20 mode /CH High	<b>Test Date:</b>	2015-9-7
<b>Temperature:</b>	25°C	<b>Tested by:</b>	Lily.Wang
<b>Humidity:</b>	55% RH	<b>Polarity:</b>	Ver. / Hor.

### Horizontal

No.	Frequency (MHz)	Reading (dBuV)	Correct Factor(dB/m)	Result (dBuV/m)	Limit (dBuV/m)	Margin (dB)	Height (cm)	Degree (deg.)	Remark
1	11107.372	39.52	4.29	43.81	74.00	-30.19	100	13	peak
2	15330.128	36.97	3.66	40.63	74.00	-33.37	100	21	peak
3	N/A								
4									
5									
6									

### Vertical

No.	Frequency (MHz)	Reading (dBuV)	Correct Factor(dB/m)	Result (dBuV/m)	Limit (dBuV/m)	Margin (dB)	Height (cm)	Degree (deg.)	Remark
1	11325.320	39.13	4.00	43.13	74.00	-30.87	100	119	peak
2	15520.833	37.66	2.75	40.41	74.00	-33.59	100	67	peak
3	N/A								
4									
5									
6									

**Remark:**

1. *Measuring frequencies from 1 GHz to the 10th harmonic of highest fundamental frequency.*
2. *Radiated emissions measured in frequency above 1000MHz were made with an instrument using peak/average detector mode.*
3. *Average test would be performed if the peak result were greater than the average limit.*
4. *Data of measurement within this frequency range shown “ --- ” in the table above means the reading of emissions are attenuated more than 20dB below the permissible limits or the field strength is too small to be measured.*
5. *Measurements above show only up to 3 maximum emissions noted, or would be lesser, with “ N/A ” remark, if no specific emissions from the EUT are recorded (ie: margin>20dB from the applicable limit) and considered that's already beyond the background noise floor.*
6. *Margin (dB) = Remark result (dBuV/m) – Average limit (dBuV/m).*

## 7.7 POWERLINE CONDUCTED EMISSIONS

### LIMIT

For equipment that is designed to be connected to the public utility (AC) power line, the radio frequency voltage that is conducted back onto the AC power line on any frequency or frequencies within the band 150 kHz to 30 MHz shall not exceed the limits in the following table.

Frequency Range (MHz)	Limits (dB $\mu$ V)	
	Quasi-peak	Average
0.15 to 0.50	66 to 56*	56 to 46*
0.50 to 5	56	46
5 to 30	60	50

\* Decreases with the logarithm of the frequency.

### TEST CONFIGURATION

See test photographs attached in Appendix 1 for the actual connections between EUT and support equipment.

### TEST PROCEDURE

1. The EUT was placed on a table, which is 0.8m above ground plane.
2. Maximum procedure was performed on the six highest emissions to ensure EUT compliance.
3. Repeat above procedures until all frequency measured were complete.

### TEST RESULTS

The initial step in collecting conducted data is a spectrum analyzer peak scan of the measurement range. Significant peaks are then marked as shown on the following data page, and these signals are then quasi-peaked.

**Test Data**

Job No.:	C151211R01	Date:	2016-1-9
Model No.:	R9861520	Time:	PM 04:23:22
Standard:	FCC Class B	Temp.(C)/Hum.(%):	22(C)/48%
Test item:	Conduction test	Test By:	Lily.Wang
Line:	L1	Test Voltage:	AC 120V/60Hz
Model:		Description:	

**L1**

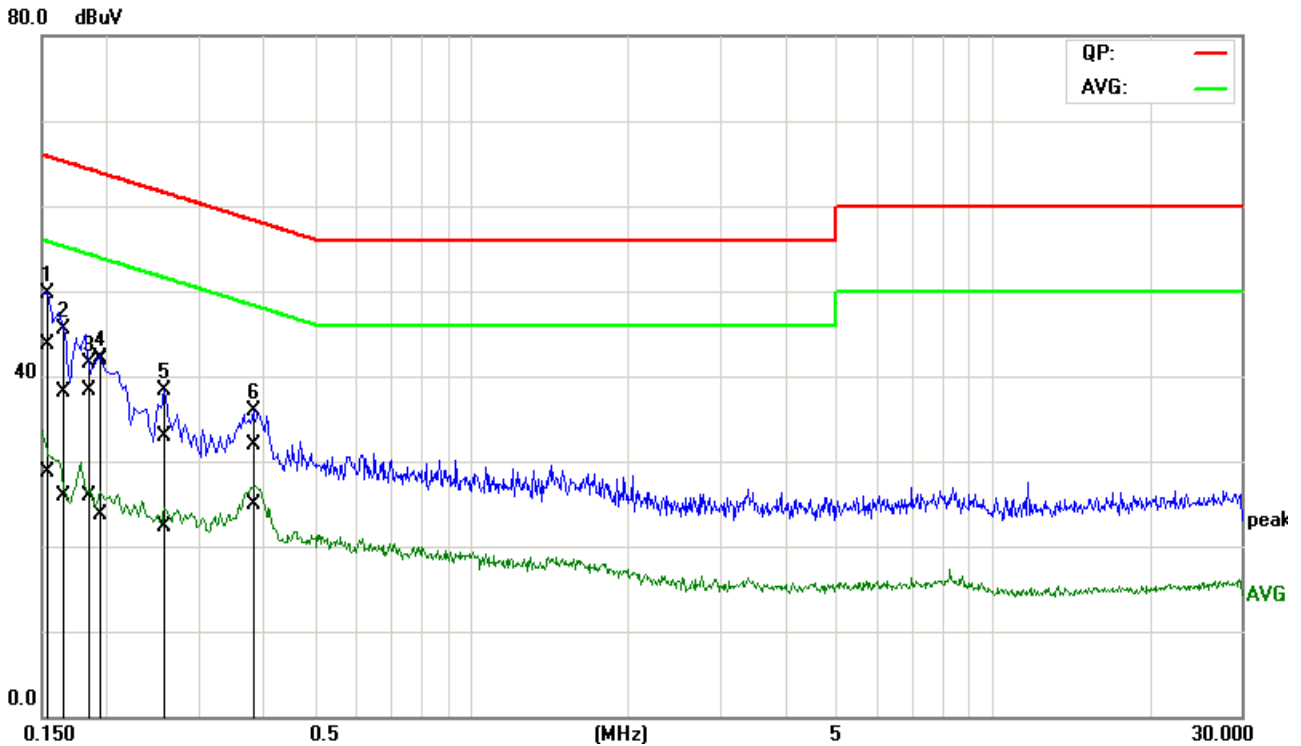

No.	Frequency (MHz)	QuasiPeak reading (dBuV)	Average reading (dBuV)	Correction factor (dB)	QuasiPeak result (dBuV)	Average result (dBuV)	QuasiPeak limit (dBuV)	Average limit (dBuV)	QuasiPeak margin (dB)	Average margin (dB)	Remark
1	0.1511	23.83	8.94	19.78	43.61	28.72	65.94	55.94	-22.33	-27.22	Pass
2	0.1663	18.39	6.07	19.78	38.17	25.85	65.14	55.14	-26.97	-29.29	Pass
3	0.1855	18.44	6.12	19.79	38.23	25.91	64.24	54.24	-26.01	-28.33	Pass
4*	0.1963	22.16	3.98	19.79	41.95	23.77	63.77	53.77	-21.82	-30.00	Pass
5	0.2577	13.13	2.45	19.79	32.92	22.24	61.51	51.51	-28.59	-29.27	Pass
6	0.3818	12.02	5.10	19.80	31.82	24.90	58.24	48.24	-26.42	-23.34	Pass

**Note:** 1. L1 = Line One (Live Line) / L2 = Line Two (Neutral Line).

Job No.:	C151211R01	Date:	2016-1-9
Model No.:	R9861520	Time:	PM 04:28:16
Standard:	FCC Class B	Temp.(C)/Hum.(%):	22(C)/48%
Test item:	Conduction test	Test By:	Lily.Wang
Line:	L2	Test Voltage:	AC 120V/60Hz
Model:		Description:	

**L2**

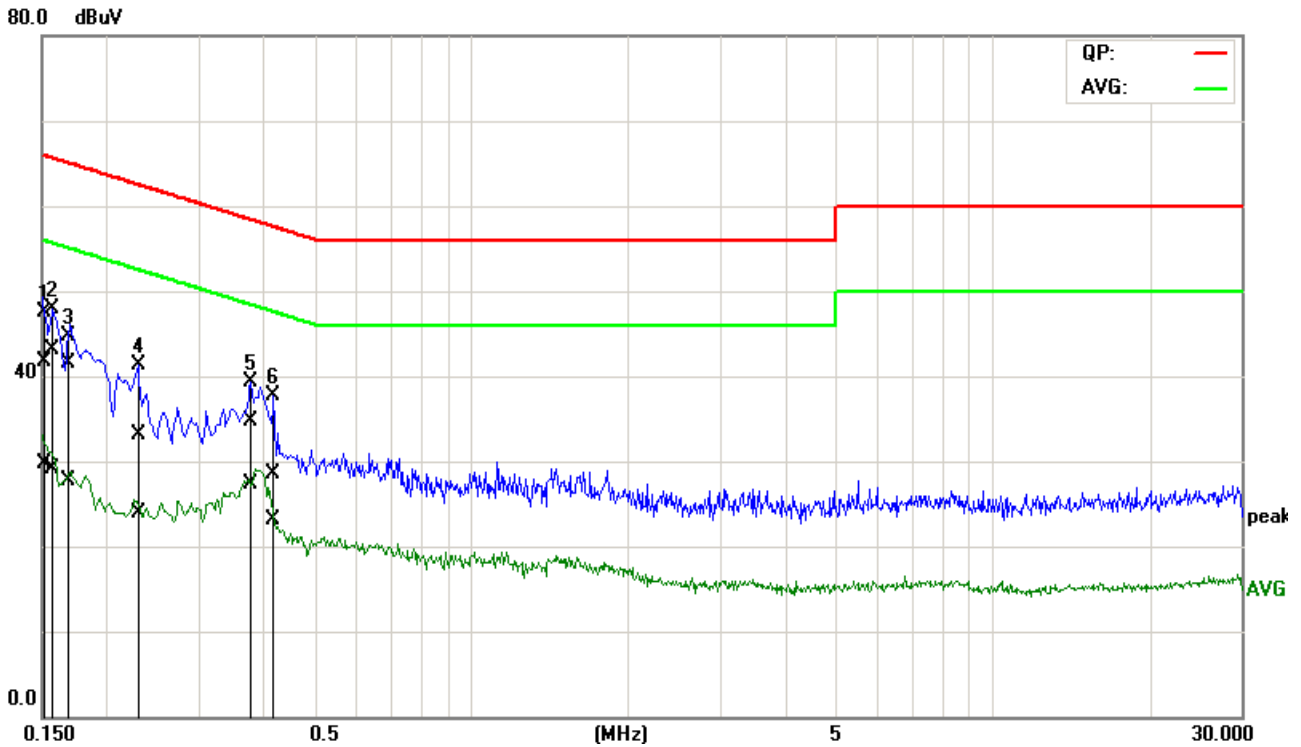

No.	Frequency (MHz)	QuasiPeak reading (dBuV)	Average reading (dBuV)	Correction factor (dB)	QuasiPeak result (dBuV)	Average result (dBuV)	QuasiPeak limit (dBuV)	Average limit (dBuV)	QuasiPeak margin (dB)	Average margin (dB)	Remark
1	0.1526	22.00	10.04	19.73	41.73	29.77	65.86	55.86	-24.13	-26.09	Pass
2	0.1557	23.35	9.35	19.73	43.08	29.08	65.69	55.69	-22.61	-26.61	Pass
3	0.1666	21.71	7.93	19.73	41.44	27.66	65.13	55.13	-23.69	-27.47	Pass
4	0.2314	13.40	4.25	19.74	33.14	23.99	62.40	52.40	-29.26	-28.41	Pass
5*	0.3797	14.95	7.64	19.75	34.70	27.39	58.29	48.29	-23.59	-20.90	Pass
6	0.4177	8.68	3.30	19.75	28.43	23.05	57.49	47.49	-29.06	-24.44	Pass

**Note:** 1. L1 = Line One (Live Line) / L2 = Line Two (Neutral Line).

Job No.:	C151211R01	Date:	2016-1-9
Model No.:	R9861520	Time:	PM 04:10:37
Standard:	FCC Class B	Temp.(C)/Hum.(%):	22(C)/48%
Test item:	Conduction test	Test By:	Lily.Wang
Line:	L1	Test Voltage:	AC 240V/60Hz
Model:		Description:	

**L1**

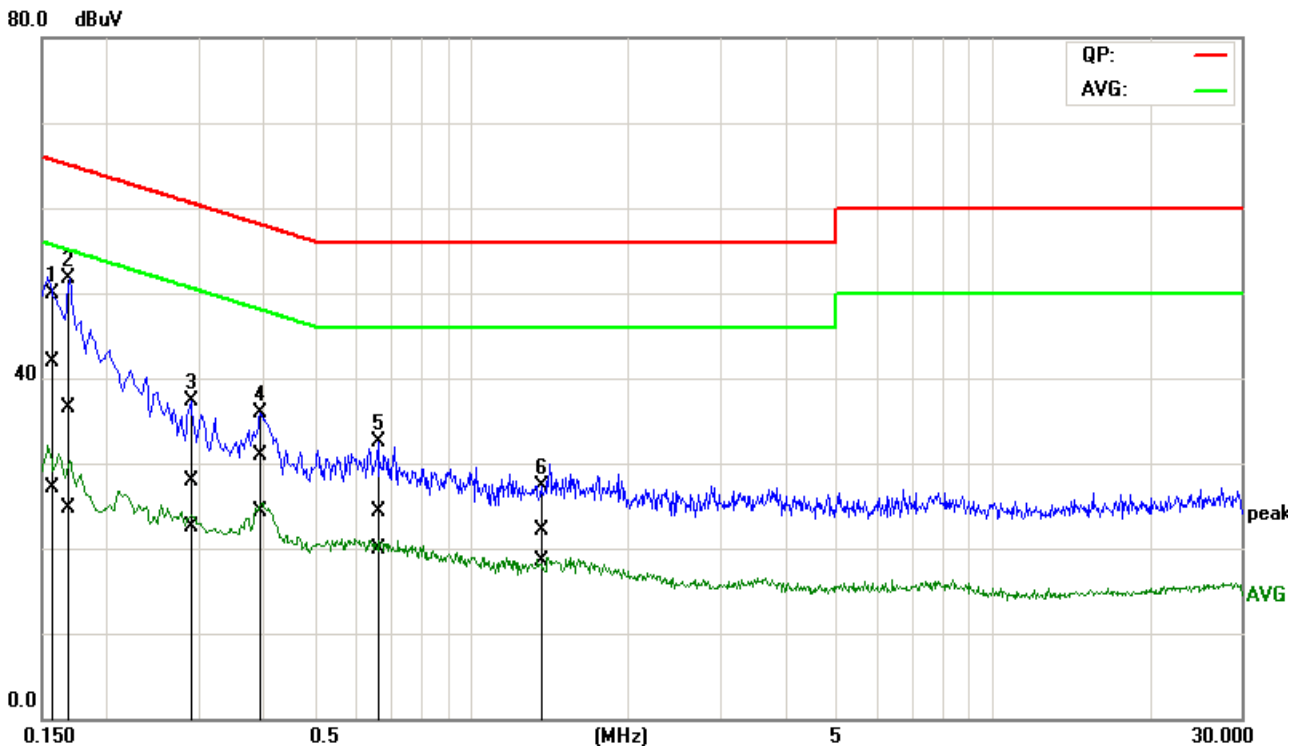

No.	Frequency (MHz)	QuasiPeak reading (dBuV)	Average reading (dBuV)	Correction factor (dB)	QuasiPeak result (dBuV)	Average result (dBuV)	QuasiPeak limit (dBuV)	Average limit (dBuV)	QuasiPeak margin (dB)	Average margin (dB)	Remark
1*	0.1584	22.16	7.36	19.78	41.94	27.14	65.55	55.55	-23.61	-28.41	Pass
2	0.1707	16.68	4.96	19.78	36.46	24.74	64.93	54.93	-28.47	-30.19	Pass
3	0.2910	8.20	2.79	19.80	28.00	22.59	60.50	50.50	-32.50	-27.91	Pass
4	0.3909	11.05	4.54	19.80	30.85	24.34	58.04	48.04	-27.19	-23.70	Pass
5	0.6668	4.47	0.14	19.81	24.28	19.95	56.00	46.00	-31.72	-26.05	Pass
6	1.3570	2.27	-1.41	19.82	22.09	18.41	56.00	46.00	-33.91	-27.59	Pass

**Note:** 1. L1 = Line One (Live Line) / L2 = Line Two (Neutral Line).

Job No.:	C151211R01	Date:	2016-1-9
Model No.:	R9861520	Time:	PM 04:18:03
Standard:	FCC Class B	Temp.(C)/Hum.(%):	22(C)/48%
Test item:	Conduction test	Test By:	Lily.Wang
Line:	L2	Test Voltage:	AC 240V/60Hz
Model:		Description:	

**L2**

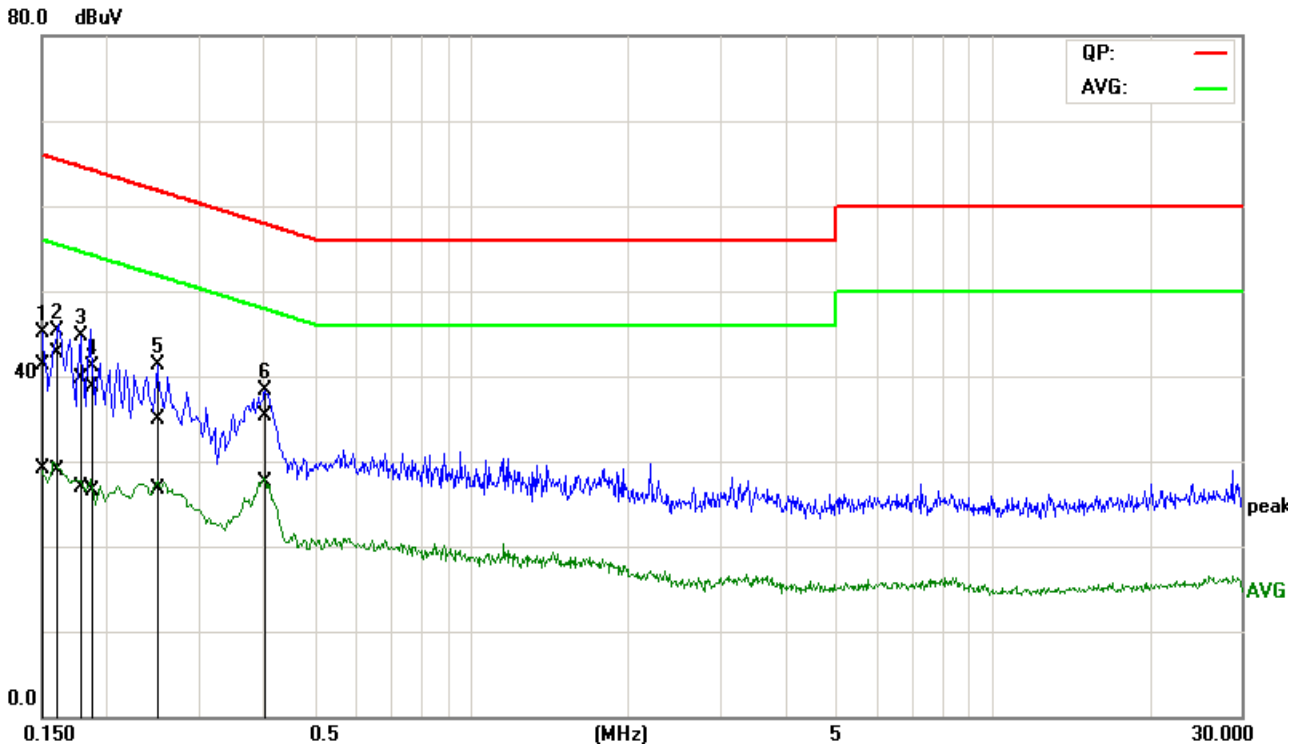

No.	Frequency (MHz)	QuasiPeak reading (dBuV)	Average reading (dBuV)	Correction factor (dB)	QuasiPeak result (dBuV)	Average result (dBuV)	QuasiPeak limit (dBuV)	Average limit (dBuV)	QuasiPeak margin (dB)	Average margin (dB)	Remark
1	0.1505	21.64	9.34	19.73	41.37	29.07	65.97	55.97	-24.60	-26.90	Pass
2	0.1587	23.05	9.27	19.73	42.78	29.00	65.53	55.53	-22.75	-26.53	Pass
3	0.1784	19.89	7.17	19.73	39.62	26.90	64.56	54.56	-24.94	-27.66	Pass
4	0.1887	18.95	6.86	19.74	38.69	26.60	64.09	54.09	-25.40	-27.49	Pass
5	0.2518	15.26	7.04	19.74	35.00	26.78	61.70	51.70	-26.70	-24.92	Pass
6*	0.3985	15.59	7.75	19.75	35.34	27.50	57.88	47.88	-22.54	-20.38	Pass

**Note:** 1. L1 = Line One (Live Line) / L2 = Line Two (Neutral Line).

**END OF REPORT**