

FCC RADIO TEST REPORT

FCC ID: RCVIMOUSEM300W

Product : Bluetooth Wireless Mouse

Trade Name : Qoo!

Model Name : iMouse M300W

Serial Model : iMouse M100, iMouse M200, iMouse M300,
iMouse S200, iMouse S300, iMouse G100,
iMouse G250, iMouse W100, iMouse W200

Report No. : PT1301060005E

Prepared for

ADESSO TECHNOLOGIES INC.

Room 501, Block2, 9 9th Gaoxin South Road, Vision Business Park,
Hi Tech Industrial Park, Nshan District Shenzhen, China

Prepared by

DongGuan Precise Testing Service Co.,Ltd.

F616A Room, 6th Floor, Meixin Business Center, Dongcheng
Middle Road, Dongguan, Guangdong, China

Tel: 86-769-23368601 Fax: 86-769-23368602 [http:// www.pts-testing.com](http://www.pts-testing.com)

TEST RESULT CERTIFICATION

Applicant's name : ADESSO TECHNOLOGIES INC.
Address : Room 501, Block2, 9 9th Gaoxin South Road, Vision
Business Park, Hi Tech Industrial Park, Nashan District
Shenzhen, China
Manufacture's Name..... : ADESSO ELECTRONIC INC.
Address : DaBanDi Industrial, DaNing Precinct, Humen, DongGuan, China
Product description
Product name : Bluetooth Wireless Mouse
Model and/or type reference : iMouse M300W
Serial Model : iMouse M100, iMouse M200, iMouse M300, iMouse S200,
iMouse S300, iMouse G100, iMouse G250, iMouse W100,
iMouse W200
Standards : FCC Part15.247:2012
Test procedure ANSI C63.4-2003, DA00-705

This device described above has been tested by PTS, and the test results show that the equipment under test (EUT) is in compliance with the FCC requirements. And it is applicable only to the tested sample identified in the report.

This report shall not be reproduced except in full, without the written approval of PTS, this document may be altered or revised by PTS, personal only, and shall be noted in the revision of the document.

Date of Test :
Date (s) of performance of tests : 19 May 2013 ~27 May 2013
Date of Issue..... : 27 May 2013
Test Result..... : **Pass**

Prepared by : 

Assistant

Reviewer : 

Supervisor

Approved & Authorized Signer : 

Jacky Ou / Manager

Table of Contents

	Page
1 . SUMMARY OF TEST RESULTS	5
1.1 TEST FACILITY	6
1.2 MEASUREMENT UNCERTAINTY	6
2 . GENERAL INFORMATION	7
2.1 GENERAL DESCRIPTION OF EUT	7
2.2 DESCRIPTION OF TEST MODES	9
2.3 TABLE OF PARAMETERS OF TEXT SOFTWARE SETTING	9
2.4 BLOCK DIGRAM SHOWING THE CONFIGURATION OF SYSTEM TESTED	10
2.5 DESCRIPTION OF SUPPORT UNITS(CONDUCTED MODE)	11
2.6 EQUIPMENTS LIST FOR ALL TEST ITEMS	12
3 . EMC EMISSION TEST	13
3.1 CONDUCTED EMISSION MEASUREMENT	13
3.1.1 POWER LINE CONDUCTED EMISSION LIMITS	13
3.1.2 TEST PROCEDURE	14
3.1.3 DEVIATION FROM TEST STANDARD	14
3.1.4 TEST SETUP	14
3.1.5 EUT OPERATING CONDITIONS	14
3.1.6 TEST RESULTS	15
3.2 RADIATED EMISSION MEASUREMENT	16
3.2.1 RADIATED EMISSION LIMITS	16
3.2.2 TEST PROCEDURE	17
3.2.3 DEVIATION FROM TEST STANDARD	17
3.2.4 TEST SETUP	18
3.2.5 EUT OPERATING CONDITIONS	19
3.2.6 TEST RESULTS (BELOW 30 MHZ)	20
3.2.7 TEST RESULTS (BETWEEN 30M – 1000 MHZ)	21
3.2.8 TEST RESULTS (ABOVE 1000 MHZ)	23
3.2.9 TEST RESULTS (RESTRICTED BANDS REQUIREMENTS)	41
4 . NUMBER OF HOPPING CHANNEL	53
4.1 APPLIED PROCEDURES / LIMIT	53
4.1.1 TEST PROCEDURE	53
4.1.2 DEVIATION FROM STANDARD	53
4.1.3 TEST SETUP	53
4.1.4 EUT OPERATION CONDITIONS	53
4.1.5 TEST RESULTS	54
5 . AVERAGE TIME OF OCCUPANCY	55

Table of Contents

	Page
5.1 APPLIED PROCEDURES / LIMIT	55
5.1.1 TEST PROCEDURE	55
5.1.2 DEVIATION FROM STANDARD	55
5.1.3 TEST SETUP	56
5.1.4 EUT OPERATION CONDITIONS	56
5.1.5 TEST RESULTS	57
6 . HOPPING CHANNEL SEPARATION MEASUREMENT	59
6.1 APPLIED PROCEDURES / LIMIT	59
6.1.1 TEST PROCEDURE	59
6.1.2 DEVIATION FROM STANDARD	59
6.1.3 TEST SETUP	59
6.1.4 EUT OPERATION CONDITIONS	59
6.1.5 TEST RESULTS	60
7 . BANDWIDTH TEST	66
7.1 APPLIED PROCEDURES / LIMIT	66
7.1.1 TEST PROCEDURE	66
7.1.2 DEVIATION FROM STANDARD	66
7.1.3 TEST SETUP	66
7.1.4 EUT OPERATION CONDITIONS	66
7.1.5 TEST RESULTS	67
8 . PEAK OUTPUT POWER TEST	73
8.1 APPLIED PROCEDURES / LIMIT	73
8.1.1 TEST PROCEDURE	73
8.1.2 DEVIATION FROM STANDARD	73
8.1.3 TEST SETUP	73
8.1.4 EUT OPERATION CONDITIONS	73
8.1.5 TEST RESULTS	74
9 . EUT TEST PHOTO	80
APPENDIX-PHOTOGRAPHS OF EUT CONSTRUCTIONAL DETAILS	

1. SUMMARY OF TEST RESULTS

Test procedures according to the technical standards:

FCC Part15 (15.247) , Subpart C			
Standard Section	Test Item	Judgment	Remark
15.207	Conducted Emission	PASS	
15.247(a)(1)	Hopping Channel Separation	PASS	
15.247(b)(1)	Peak Output Power	PASS	
15.247(c)	Radiated Spurious Emission	PASS	
15.247(a)(iii)	Number of Hopping Frequency	PASS	
15.247(a)(iii)	Dwell Time	PASS	
15.247(a)(1)	Bandwidth	PASS	
15.205	Band Edge Emission	PASS	
15.203	Antenna Requirement	PASS	

NOTE:

(1) "N/A" denotes test is not applicable in this Test Report

1.1 TEST FACILITY

NTEK Testing Technology Co., Ltd.

Add. : 1/F, Building E, Fenda Science Park, Sanwei Community, Xixiang Street, Bao'an District, Shenzhen P.R. China.

FCC Registration Number: 238937; IC Registration Number: 9270A-1

CNAS Registration Number: L5516

1.2 MEASUREMENT UNCERTAINTY

The reported uncertainty of measurement $y \pm U$, where expanded uncertainty U is based on a standard uncertainty multiplied by a coverage factor of $k=2$, providing a level of confidence of approximately **95 %**.

No.	Item	Uncertainty
1	Conducted Emission Test	$\pm 1.38\text{dB}$
2	RF power,conducted	$\pm 0.16\text{dB}$
3	Spurious emissions,conducted	$\pm 0.21\text{dB}$
4	All emissions,radiated(<1G)	$\pm 4.68\text{dB}$
5	All emissions,radiated(>1G)	$\pm 4.89\text{dB}$
6	Temperature	$\pm 0.5^{\circ}\text{C}$
7	Humidity	$\pm 2\%$

2. GENERAL INFORMATION

2.1 GENERAL DESCRIPTION OF EUT

Equipment	Bluetooth Wireless Mouse	
Model Name	iMouse M300W	
Serial Model	iMouse M100, iMouse M200, iMouse M300, iMouse S200, iMouse S300, iMouse G100, iMouse G250, iMouse W100, iMouse W200	
Model Difference	All models are identical except model names.	
Product Description	The EUT is a Bluetooth Wireless Mouse	
	Operation Frequency:	2402~2480 MHz
	Modulation Type:	BT(1Mbps): GFSK BT EDR(2Mbps): $\pi/4$ -DQPSK BT EDR(3Mbps): 8-DPSK
	Bit Rate of Transmitter	1Mbps/2Mbps/3Mbps
	Number Of Channel	79 CH
	Antenna Designation:	Please see Note 3.
	Output Power(Conducted):	BT(1Mbps): 0.931dBm BT EDR(2Mbps): 0.824dBm BT EDR(3Mbps): -0.696dBm
Channel List	Please refer to the Note 2.	
Adapter	N/A	
Battery	1.5V*2"AAA" battery	
Connecting I/O Port(s)	Please refer to the User's Manual	

Note:

1. For a more detailed features description, please refer to the manufacturer's specifications or the User's Manual.

2.

Channel List					
Channel	Frequency (MHz)	Channel	Frequency (MHz)	Channel	Frequency (MHz)
00	2402	27	2429	54	2456
01	2403	28	2430	55	2457
02	2404	29	2431	56	2458
03	2405	30	2432	57	2459
04	2406	31	2433	58	2460
05	2407	32	2434	59	2461
06	2408	33	2435	60	2462
07	2409	34	2436	61	2463
08	2410	35	2437	62	2464
09	2411	36	2438	63	2465
10	2412	37	2439	64	2466
11	2413	38	2440	65	2467
12	2414	39	2441	66	2468
13	2415	40	2442	67	2469
14	2416	41	2443	68	2470
15	2417	42	2444	69	2471
16	2418	43	2445	70	2472
17	2419	44	2446	71	2473
18	2420	45	2447	72	2474
19	2421	46	2448	73	2475
20	2422	47	2449	74	2476
21	2423	48	2450	75	2477
22	2424	49	2451	76	2478
23	2425	50	2452	77	2479
24	2426	51	2453	78	2480
25	2427	52	2454		
26	2428	53	2455		

3.

Table for Filed Antenna

Ant	Brand	Model Name	Antenna Type	Connector	Gain (dBi)	NOTE
1	N/A	N/A	FPCB Antenna	NA	0	BT Antenna

2.2 DESCRIPTION OF TEST MODES

To investigate the maximum EMI emission characteristics generates from EUT, the test system was pre-scanning tested base on the consideration of following EUT operation mode or test configuration mode which possible have effect on EMI emission level. Each of these EUT operation mode(s) or test configuration mode(s) mentioned above was evaluated respectively.

Pretest Mode	Description
Mode 1	CH00
Mode 2	CH39
Mode 3	CH78

For Conducted Emission	
Final Test Mode	Description
N/A	N/A

For Radiated Emission	
Final Test Mode	Description
Mode 1	CH00
Mode 2	CH39
Mode 3	CH78

Note:

- (1) The measurements are performed at the highest, middle, lowest available channels.
- (2) The EUT use new battery.
- (3)The data rate was set in 1Mbps for radiated emission due to the highest RF output power.

2.3 TABLE OF PARAMETERS OF TEXT SOFTWARE SETTING

During testing channel & power controlling software provided by the customer was used to control the operating channel as well as the output power level. The RF output power selection is for the setting of RF output power expected by the customer and is going to be fixed on the firmware of the final end product power parameters of FHSS

Test software Version	Test program: N/A		
Frequency	2402 MHz	2441 MHz	2480 MHz
Parameters(1Mbps/2Mbps/3Mbps)	DEF	DEF	DEF

2.4 BLOCK DIGRAM SHOWING THE CONFIGURATION OF SYSTEM TESTED

Radiated Spurious Emission Test

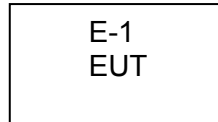

2.5 DESCRIPTION OF SUPPORT UNITS(CONDUCTED MODE)

The EUT has been tested as an independent unit together with other necessary accessories or support units. The following support units or accessories were used to form a representative test configuration during the tests.

Item	Equipment	Mfr/Brand	Model/Type No.	Series No.	Note
E-1	Bluetooth Wireless Mouse	N/A	iMouse M300W	N/A	EUT

Item	Shielded Type	Ferrite Core	Length	Note

Note:

- (1) The support equipment was authorized by Declaration of Confirmation.
- (2) For detachable type I/O cable should be specified the length in cm in 『Length』 column.
- (3) “YES” is means “shielded” “with core”; “NO” is means “unshielded” “without core”.

2.6 EQUIPMENTS LIST FOR ALL TEST ITEMS

Item	Kind of Equipment	Manufacturer	Type No.	Serial No.	Last calibration	Calibrated until	Calibration period
1	Spectrum Analyzer	Agilent	E4407B	160400005	2012.07.06	2013.07.05	1 year
2	Test Receiver	R&S	ESPI	101318	2012.07.06	2013.07.05	1 year
3	Bilog Antenna	TESEQ	CBL6111D	31216	2013.06.07	2014.06.06	1 year
4	50Ω Coaxial Switch	Anritsu	MP59B	6200264416	2012.07.06	2013.07.05	1 year
5	Spectrum Analyzer	ADVANTES T	R3132	150900201	2013.06.07	2014.06.06	1 year
6	Horn Antenna	EM	EM-AH-20180	2011071402	2013.06.07	2014.06.06	1 year
7	Horn Ant	Schwarzbeck	BBHA 9170	9170-181	2013.06.07	2014.06.06	1 year
8	Amplifier	EM	EM-30180	060538	2012.07.06	2013.07.05	1 year
9	Loop Antenna	ARA	PLA-2030/B	1029	2013.06.07	2014.06.06	1 year
10	Power Meter	R&S	NRVS	100696	2012.07.06	2013.07.05	1 year
11	Signal Generator	R&S	SMT 06	832080/007	2012.07.06	2013.07.05	1 year
12	Temperature & Humidity Chamber	GIANT FORCE	GTH-056P	GF-94454-1	2012.07.06	2013.07.05	1 year
13	Power Sensor	R&S	URV5-Z4	0395.1619.05	2013.06.07	2014.06.06	1 year

3. EMC EMISSION TEST

3.1 CONDUCTED EMISSION MEASUREMENT

3.1.1 POWER LINE CONDUCTED EMISSION Limits (Frequency Range 150KHz-30MHz)

FREQUENCY (MHz)	Class A (dBuV)		Class B (dBuV)		Standard
	Quasi-peak	Average	Quasi-peak	Average	
0.15 -0.5	79.00	66.00	66 - 56 *	56 - 46 *	CISPR
0.50 -5.0	73.00	60.00	56.00	46.00	CISPR
5.0 -30.0	73.00	60.00	60.00	50.00	CISPR

0.15 -0.5	79.00	66.00	66 - 56 *	56 - 46 *	FCC
0.50 -5.0	73.00	60.00	56.00	46.00	FCC
5.0 -30.0	73.00	60.00	60.00	50.00	FCC

Note:

- (1) The tighter limit applies at the band edges.
- (2) The limit of " * " marked band means the limitation decreases linearly with the logarithm of the frequency in the range.

The following table is the setting of the receiver

Receiver Parameters	Setting
Attenuation	10 dB
Start Frequency	0.15 MHz
Stop Frequency	30 MHz
IF Bandwidth	9 kHz

3.1.2 TEST PROCEDURE

- a. The EUT was placed 0.4 meters from the horizontal ground plane with EUT being connected to the power mains through a line impedance stabilization network (LISN). All other support equipments powered from additional LISN(s). The LISN provide 50 Ohm/ 50uH of coupling impedance for the measuring instrument.
- b. Interconnecting cables that hang closer than 40 cm to the ground plane shall be folded back and forth in the center forming a bundle 30 to 40 cm long.
- c. I/O cables that are not connected to a peripheral shall be bundled in the center. The end of the cable may be terminated, if required, using the correct terminating impedance. The overall length shall not exceed 1 m.
- d. LISN at least 80 cm from nearest part of EUT chassis.
- e. For the actual test configuration, please refer to the related Item –EUT Test Photos.

3.1.3 DEVIATION FROM TEST STANDARD

No deviation

3.1.4 TEST SETUP

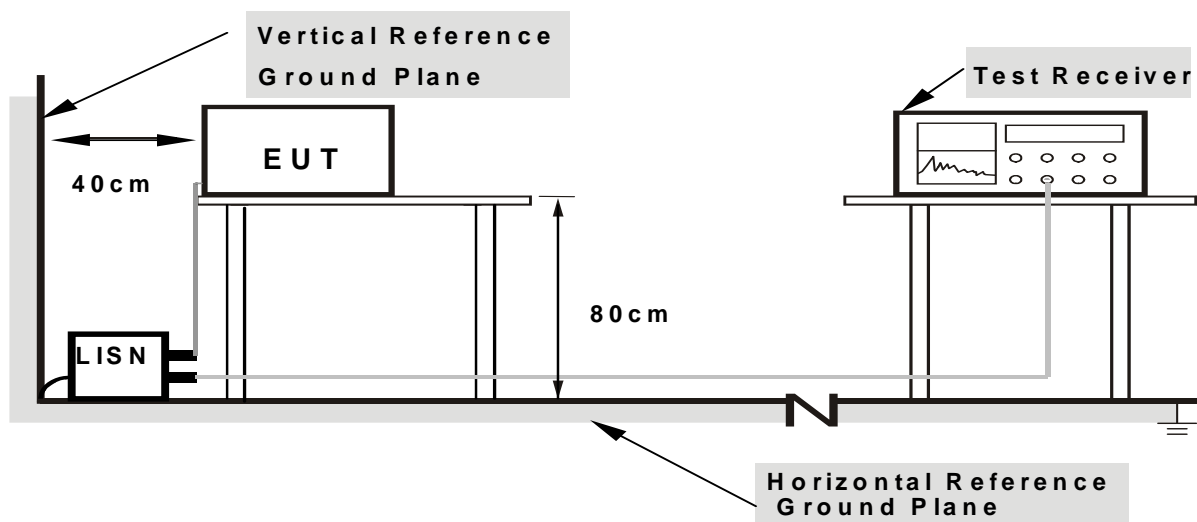

Note: 1. Support units were connected to second LISN.

2. Both of LISNs (AMN) are 80 cm from EUT and at least 80 cm from other units and other metal planes

3.1.5 EUT OPERATING CONDITIONS

The EUT was configured for testing in a typical fashion (as a customer would normally use it). The EUT has been programmed to continuously transmit during test. This operating condition was tested and used to collect the included data.

3.1.6 TEST RESULTS

EUT :	Bluetooth Wireless Mouse	Model Name :	iMouse M300W
Temperature :	26 °C	Relative Humidity :	54%
Pressure :	1010hPa	Phase :	N/A
Test Voltage :	N/A	Test Mode :	N/A

Due to this EUT is powered by the battery only, this Measurement is not applicable.

3.2 RADIATED EMISSION MEASUREMENT

3.2.1 RADIATED EMISSION LIMITS (Frequency Range 9kHz-1000MHz)

20dBc in any 100 kHz bandwidth outside the operating frequency band. In case the emission fall within the restricted band specified on 15.205(a), then the 15.209(a) limit in the table below has to be followed.

Frequencies (MHz)	Field Strength (micorvolts/meter)	Measurement Distance (meters)
0.009~0.490	2400/F(KHz)	300
0.490~1.705	24000/F(KHz)	30
1.705~30.0	30	30
30~88	100	3
88~216	150	3
216~960	200	3
Above 960	500	3

LIMITS OF RADIATED EMISSION MEASUREMENT (Above 1000MHz)

FREQUENCY (MHz)	(dBuV/m) (at 3M)	
	PEAK	AVERAGE
Above 1000	74	54

Notes:

- (1) The limit for radiated test was performed according to FCC PART 15C.
- (2) The tighter limit applies at the band edges.
- (3) Emission level (dBuV/m)=20log Emission level (uV/m).

FREQUENCY RANGE OF RADIATED MEASUREMENT (For intentional radiators)

- (1) If the intentional radiator operates below 10 GHz: to the tenth harmonic of the highest fundamental frequency or to 40 GHz, whichever is lower.
- (2) If the intentional radiator operates at or above 10 GHz and below 30 GHz: to the fifth harmonic of the highest fundamental frequency or to 100 GHz, whichever is lower.
- (3) If the intentional radiator operates at or above 30 GHz: to the fifth harmonic of the highest fundamental frequency or to 200 GHz, whichever is lower, unless specified otherwise elsewhere in the rules.

Spectrum Parameter	Setting
Attenuation	Auto
Start Frequency	1000 MHz
Stop Frequency	10th carrier harmonic
RB / VB (emission in restricted band)	1 MHz / 1 MHz for Peak, 1 MHz / 10Hz for Average

Receiver Parameter	Setting
Attenuation	Auto
Start ~ Stop Frequency	9kHz~150kHz / RB 200Hz for QP
Start ~ Stop Frequency	150kHz~30MHz / RB 9kHz for QP
Start ~ Stop Frequency	30MHz~1000MHz / RB 120kHz for QP

3.2.2 TEST PROCEDURE

- a. The measuring distance of at 3 m shall be used for measurements at frequency up to 1GHz. For frequencies above 1GHz, any suitable measuring distance may be used.
- b. The EUT was placed on the top of a rotating table 0.8 meters above the ground at a 3 meter open area test site. The table was rotated 360 degrees to determine the position of the highest radiation.
- c. The height of the equipment or of the substitution antenna shall be 0.8 m; the height of the test antenna shall vary between 1 m to 4 m. Both horizontal and vertical polarizations of the antenna are set to make the measurement.
- d. The initial step in collecting conducted emission data is a spectrum analyzer peak detector mode pre-scanning the measurement frequency range. Significant peaks are then marked and then Quasi Peak detector mode re-measured.
- e. If the Peak Mode measured value compliance with and lower than Quasi Peak Mode Limit, the EUT shall be deemed to meet QP Limits and then no additional QP Mode measurement performed.
- f. For the actual test configuration, please refer to the related Item –EUT Test Photos.

Note:

Both horizontal and vertical antenna polarities were tested and performed pretest to three orthogonal axis. The worst case emissions were reported

3.2.3 DEVIATION FROM TEST STANDARD

No deviation

3.2.4 TEST SETUP

(A) Radiated Emission Test-Up Frequency Below 30MHz

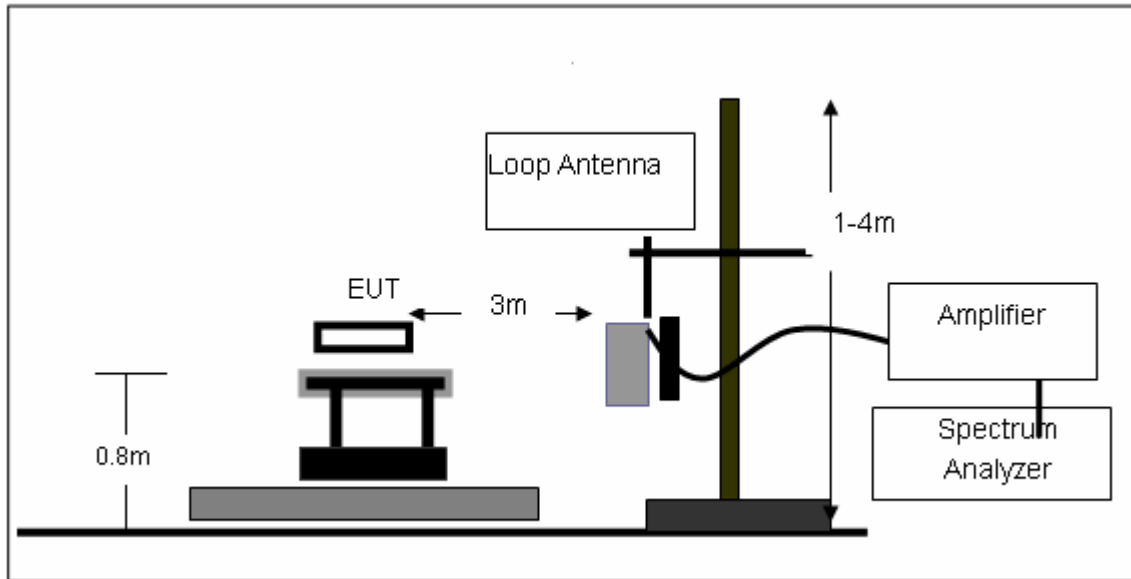

(B) Radiated Emission Test-Up Frequency 30MHz~1GHz

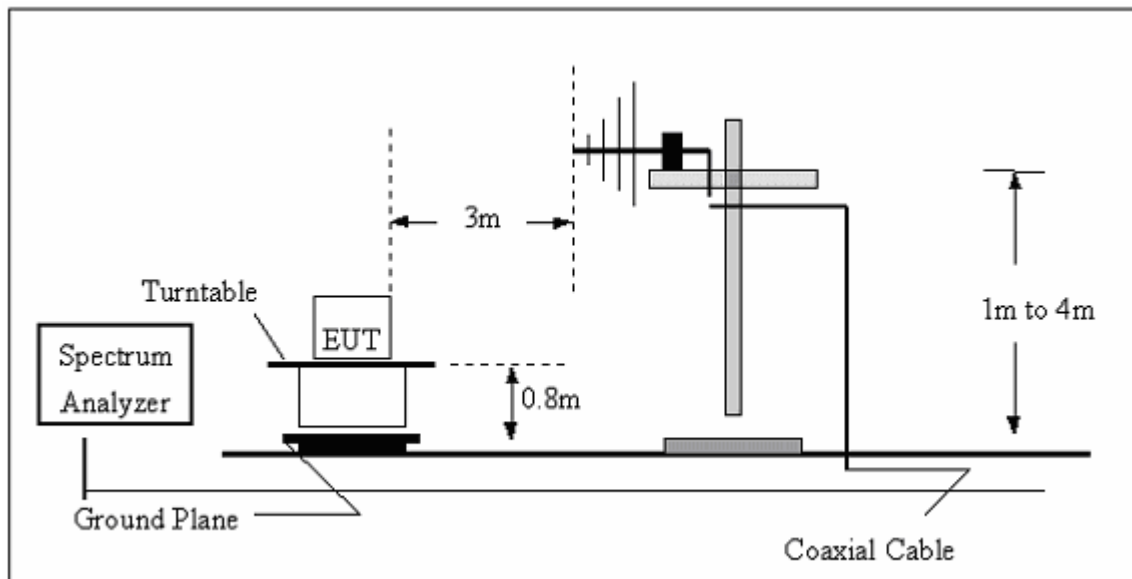

(C) Radiated Emission Test-Up Frequency Above 1GHz

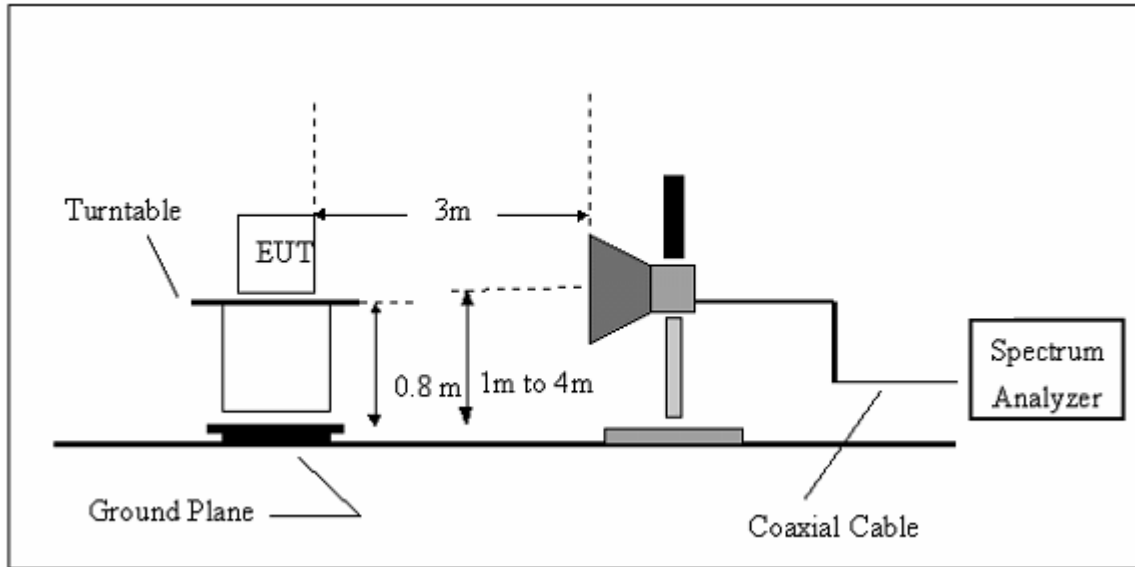

3.2.5 EUT OPERATING CONDITIONS

The EUT tested system was configured as the statements of 2.4 Unless otherwise a special operating condition is specified in the follows during the testing.

3.2.6 TEST RESULTS (BELOW 30 MHZ)

EUT :	Bluetooth Wireless Mouse	Model Name :	iMouse M300W
Temperature :	20 °C	Relative Humidity :	48%
Pressure :	1010 hPa	Polarization :	---
Test Voltage :	DC 3V		
Test Mode :	TX		

Freq.	Reading	Limit	Margin	State
(MHz)	(dBuV/m)	(dBuV/m)	(dB)	P/F
--	--	--	--	PASS
--	--	--	--	PASS

NOTE:

The amplitude of spurious emissions which are attenuated by more than 20dB below the permissible value has no need to be reported.

Distance extrapolation factor = $20 \log(\text{specific distance}/\text{test distance})(\text{dB})$;

Limit line = specific limits(dBuv) + distance extrapolation factor.

3.2.7 TEST RESULTS (BETWEEN 30M – 1000 MHZ)

EUT :	Bluetooth Wireless Mouse	Model Name :	iMouse M300W
Temperature :	20 °C	Relative Humidity :	48%
Pressure :	1010 hPa	Polarization :	Horizontal
Test Voltage :	DC 3V		
Test Mode :	TX 2402		

Frequency (MHz)	Meter Reading (dBµV)	Factor (dB)	Emission Level (dBµV/m)	Limits (dBµV/m)	Margin (dB)	Detector Type
88.67	26.58	9.17	35.75	43.5	-7.75	QP
124.37	23.77	11.89	35.66	43.5	-7.84	QP
267.35	26.74	13.68	40.42	46	-5.58	QP
300.66	24.11	14.58	38.69	46	-7.31	QP
486.52	17.21	18.97	36.18	46	-9.82	QP

Remark:
 Factor = Antenna Factor + Cable Loss – Pre-amplifier.
 All interfaces was connected, and BT TX mode was link.

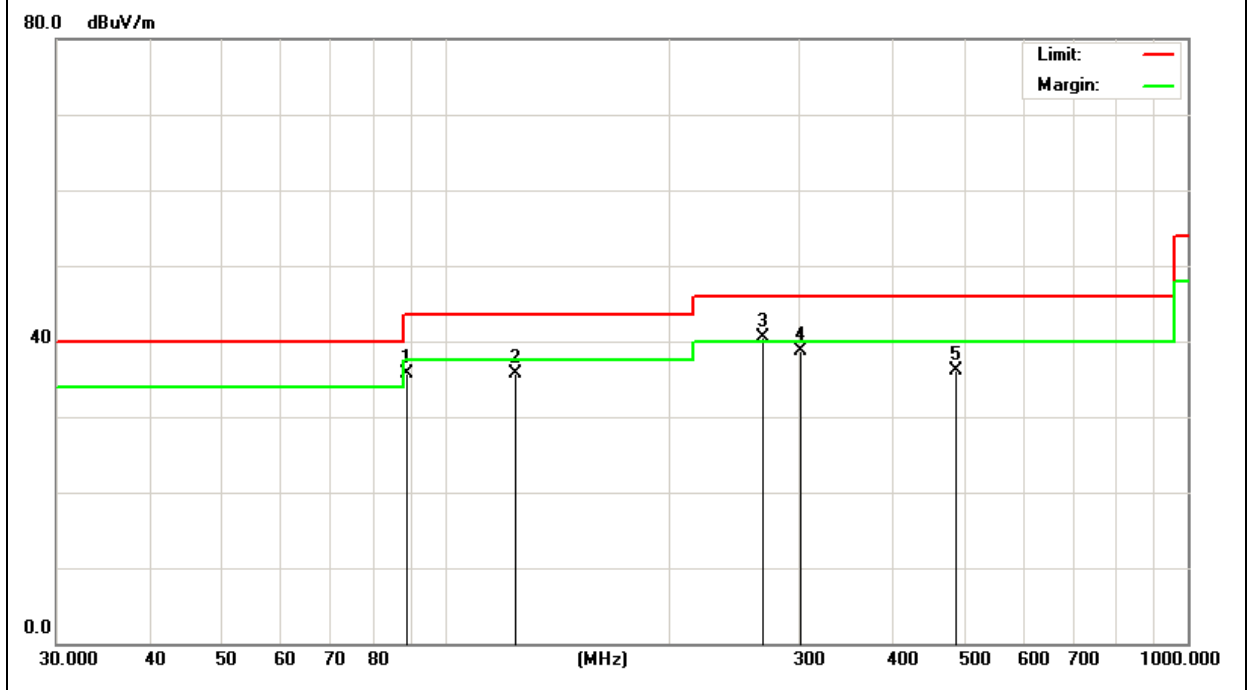

EUT :	Bluetooth Wireless Mouse	Model Name :	iMouse M300W
Temperature :	20 °C	Relative Humidity :	48%
Pressure :	1010 hPa	Polarization :	Vertical
Test Voltage :	DC 3V		
Test Mode :	TX 2402		

Frequency (MHz)	Meter Reading (dBμV)	Factor (dB)	Emission Level (dBμV/m)	Limits (dBμV/m)	Margin (dB)	Detector Type
31.24	13.66	17.73	31.39	40	-8.61	QP
108.35	23.72	11.25	34.97	43.5	-8.53	QP
190.33	29.04	8.74	37.78	43.5	-5.72	QP
200.357	28.85	8.72	37.57	43.5	-5.93	QP
332.54	21.6	14.99	36.59	46	-9.41	QP

Remark:
 Factor = Antenna Factor + Cable Loss – Pre-amplifier.
 All interfaces was connected, and BT TX mode was link.

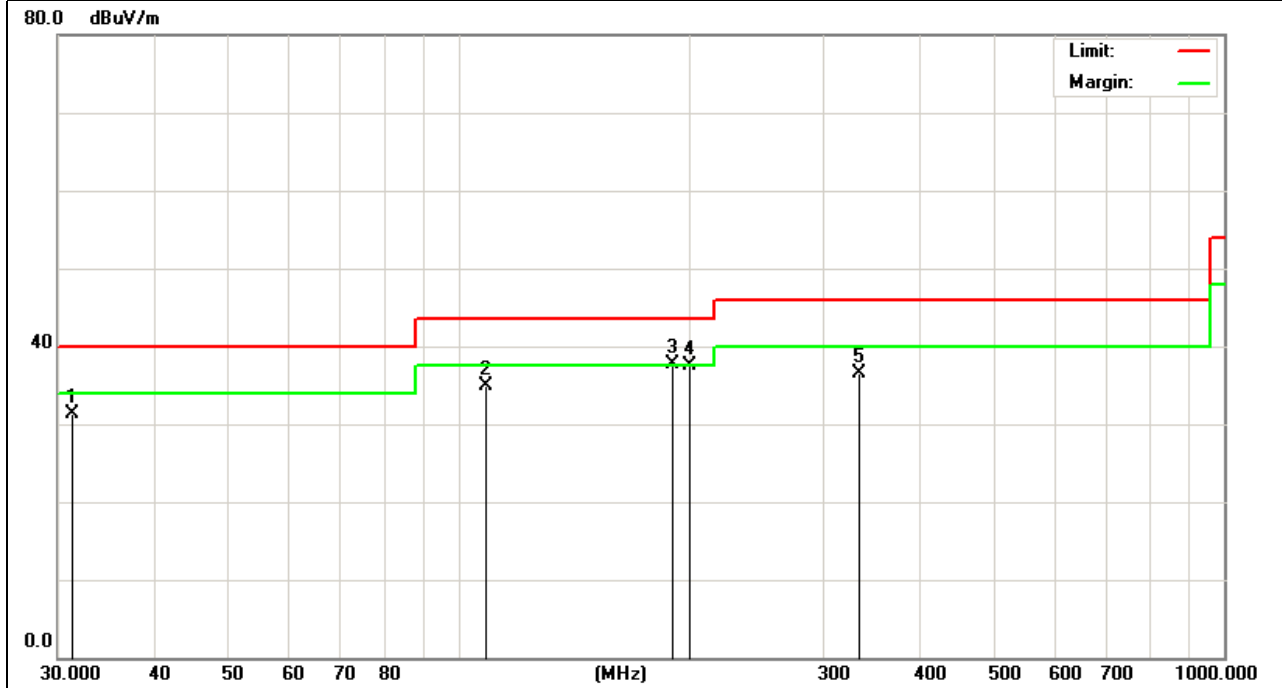

3.2.8 TEST RESULTS (ABOVE 1000 MHZ) 1000-26000MHz

The amplitude of spurious emissions which are attenuated by more than 20dB below the permissible value has no need to be reported.

EUT :	Bluetooth Wireless Mouse	Model Name :	iMouse M300W
Temperature :	20 °C	Relative Humidity :	48%
Pressure :	1010 hPa	Test Voltage :	DC 3V
Test Mode :	TX 2402MHz – CH 00(1Mbps)	Polarization :	Horizontal

Frequency (MHz)	Meter Reading (dBµV)	Factor (dB)	Emission Level (dBµV/m)	Limits (dBµV/m)	Margin (dB)	Detector Type
1212.24	28.12	25.43	53.55	74	-20.45	peak
1212.24	17.35	25.43	42.78	54	-11.22	AVG
4804.38	20.26	35.6	55.86	74	-18.14	peak
4804.38	14.06	35.6	49.66	54	-4.34	AVG
7206.33	17.33	36.26	53.59	74	-20.41	peak
7206.33	8.06	36.26	44.32	54	-9.68	AVG
9608.52	14.03	37.94	51.97	74	-22.03	peak
9608.52	6.07	37.94	44.01	54	-9.99	AVG

Remark:
Factor = Antenna Factor + Cable Loss – Pre-amplifier.

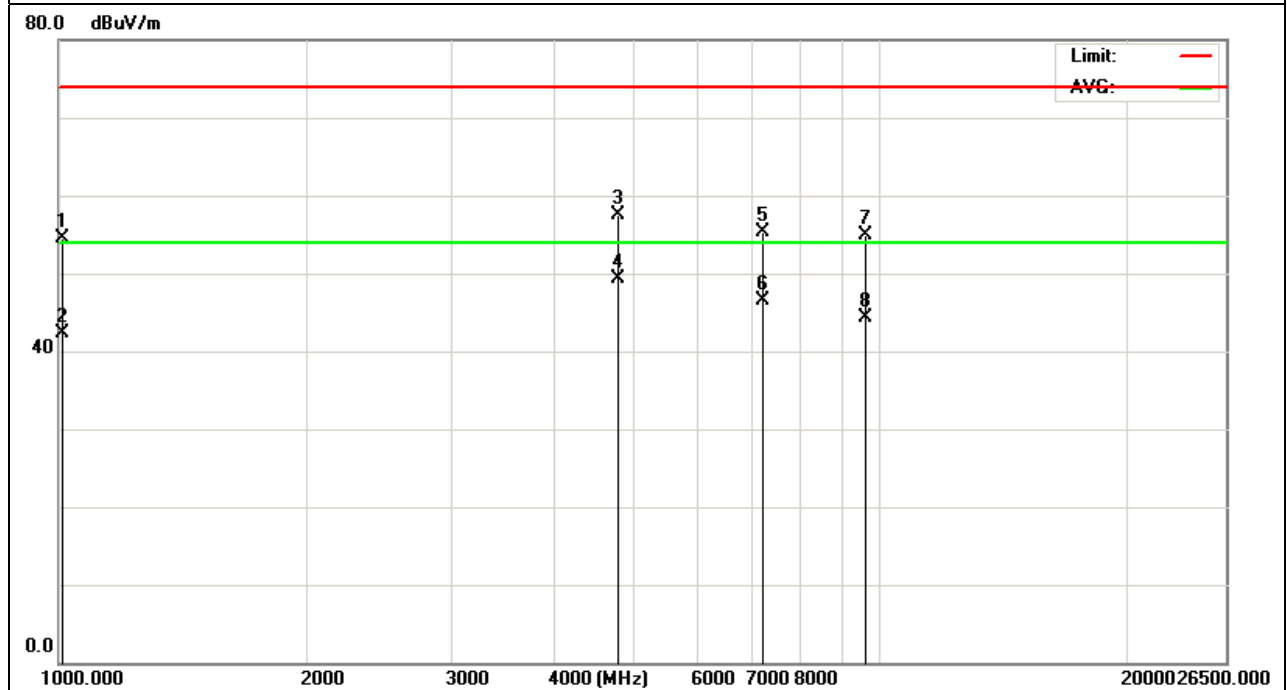

EUT :	Bluetooth Wireless Mouse	Model Name :	iMouse M300W
Temperature :	20 °C	Relative Humidity :	48%
Pressure :	1010 hPa	Test Voltage :	DC 3V
Test Mode :	TX 2402MHz – CH 00(1Mbps)	Polarization :	Vertical

Frequency (MHz)	Meter Reading (dBµV)	Factor (dB)	Emission Level (dBµV/m)	Limits (dBµV/m)	Margin (dB)	Detector Type
1008.36	30.25	24.23	54.48	74	-19.52	peak
1008.36	18.02	24.23	42.25	54	-11.75	AVG
4805.2	22	35.6	57.6	74	-16.4	peak
4805.2	13.68	35.6	49.28	54	-4.72	AVG
7208.64	18.97	36.26	55.23	74	-18.77	peak
7208.64	10.24	36.26	46.5	54	-7.5	AVG
9608.77	16.87	37.94	54.81	74	-19.19	peak

Remark:
Factor = Antenna Factor + Cable Loss – Pre-amplifier.

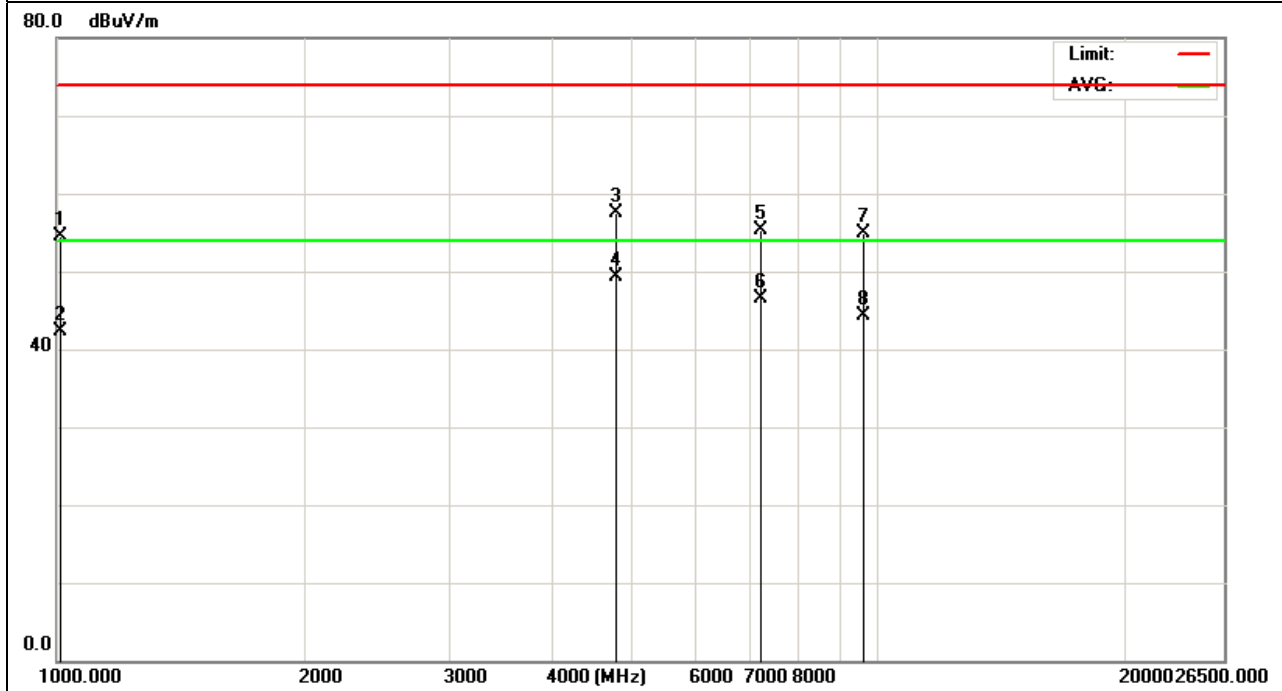

EUT :	Bluetooth Wireless Mouse	Model Name :	iMouse M300W
Temperature :	20 °C	Relative Humidity :	48%
Pressure :	1010 hPa	Test Voltage :	DC 3V
Test Mode :	TX 2441MHz – CH 39(1Mbps)	Polarization :	Vertical

Frequency (MHz)	Meter Reading (dBµV)	Factor (dB)	Emission Level (dBµV/m)	Limits (dBµV/m)	Margin (dB)	Detector Type
4882.18	21.07	35.46	56.53	74	-17.47	peak
4882.18	13	35.46	48.46	54	-5.54	AVG
7322.57	18.28	36.51	54.79	74	-19.21	peak
7322.57	8.88	36.51	45.39	54	-8.61	AVG
9764.09	14.27	37.01	51.28	74	-22.72	peak
9764.09	6.57	37.01	43.58	54	-10.42	AVG

Remark:
Factor = Antenna Factor + Cable Loss – Pre-amplifier.

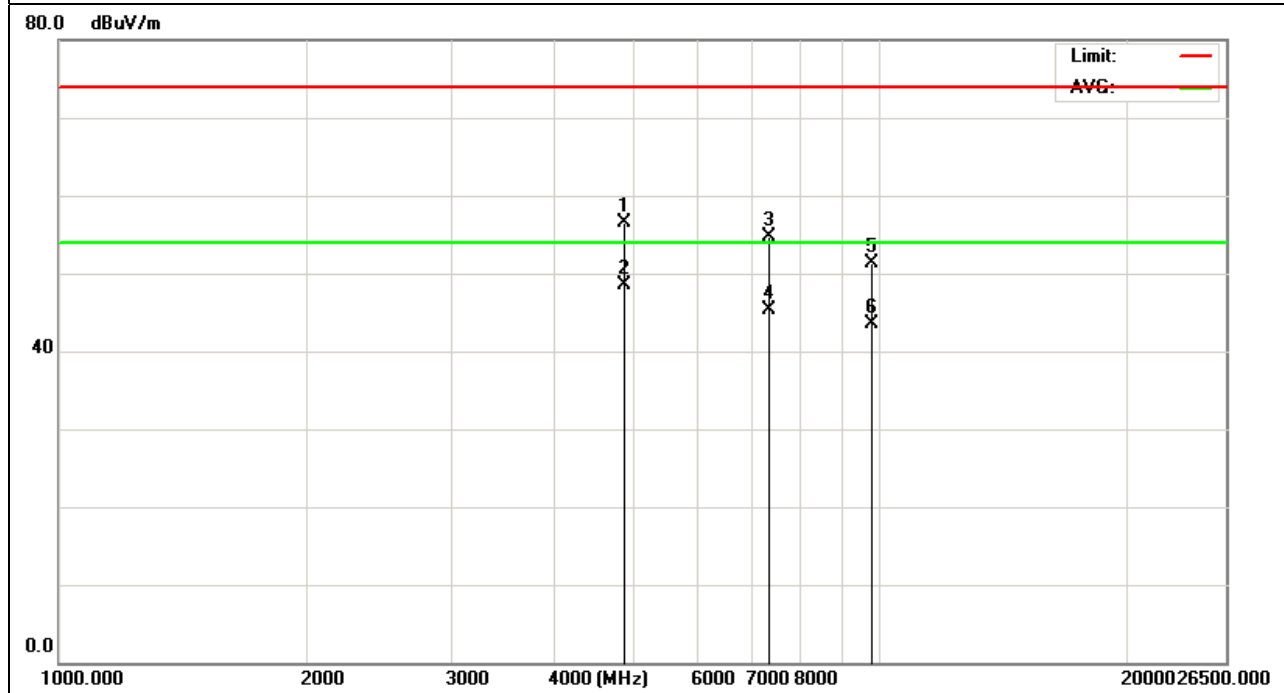

EUT :	Bluetooth Wireless Mouse	Model Name :	iMouse M300W
Temperature :	20 °C	Relative Humidity :	48%
Pressure :	1010 hPa	Test Voltage :	DC 3V
Test Mode :	TX 2441MHz – CH 39(1Mbps)	Polarization :	Horizontal

Frequency (MHz)	Meter Reading (dBµV)	Factor (dB)	Emission Level (dBµV/m)	Limits (dBµV/m)	Margin (dB)	Detector Type
4882.97	21.87	35.46	57.33	74	-16.67	peak
4882.97	13.69	35.46	49.15	54	-4.85	AVG
7323.33	17.35	36.51	53.86	74	-20.14	peak
7323.33	8.8	36.51	45.31	54	-8.69	AVG
9764.11	14.37	37.01	51.38	74	-22.62	peak
9764.11	5.28	37.01	42.29	54	-11.71	AVG

Remark:
Factor = Antenna Factor + Cable Loss – Pre-amplifier.

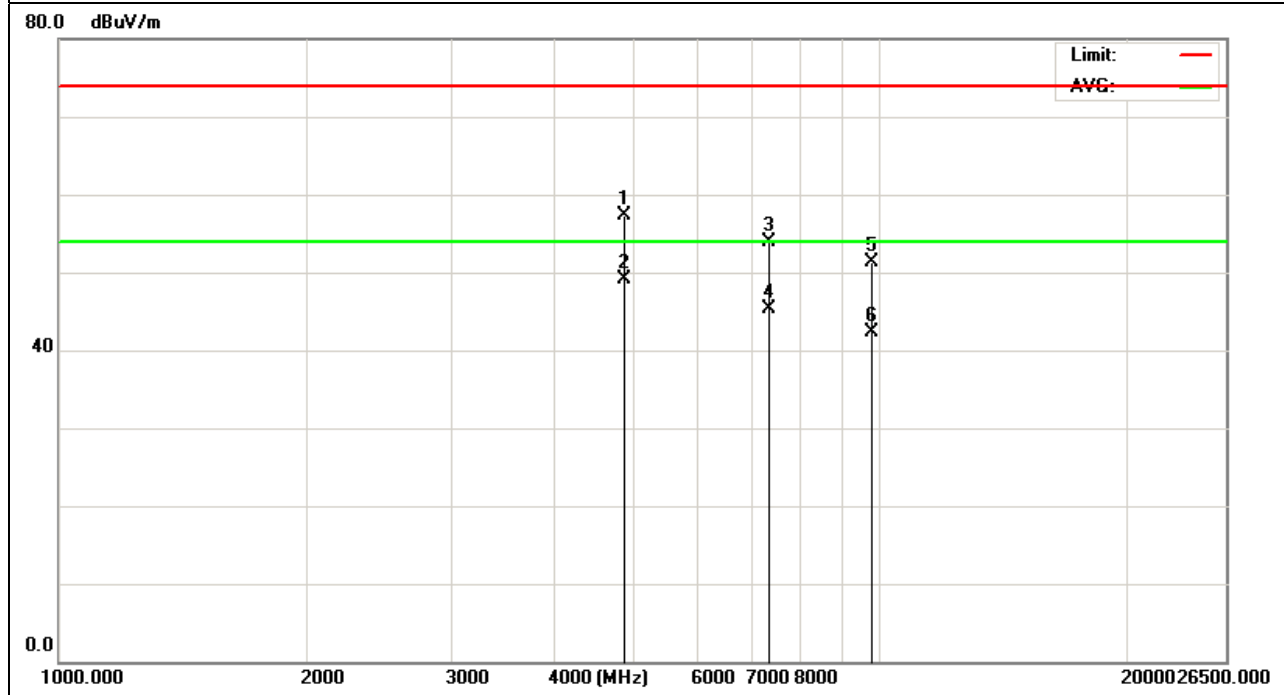

EUT :	Bluetooth Wireless Mouse	Model Name :	iMouse M300W
Temperature :	20 °C	Relative Humidity :	48%
Pressure :	1010 hPa	Test Voltage :	DC 3V
Test Mode :	TX 2480MHz – CH 78(1Mbps)	Polarization :	Horizontal

Frequency (MHz)	Meter Reading (dBµV)	Factor (dB)	Emission Level (dBµV/m)	Limits (dBµV/m)	Margin (dB)	Detector Type
4954.66	21.27	35.49	56.76	74	-17.24	peak
4954.66	13.97	35.49	49.46	54	-4.54	AVG
7431.05	17.25	36.65	53.9	74	-20.1	peak
7431.05	8.5	36.65	45.15	54	-8.85	AVG
9908.2	14.07	37.52	51.59	74	-22.41	peak
9908.2	6.33	37.52	43.85	54	-10.15	AVG

Remark:
Factor = Antenna Factor + Cable Loss – Pre-amplifier.

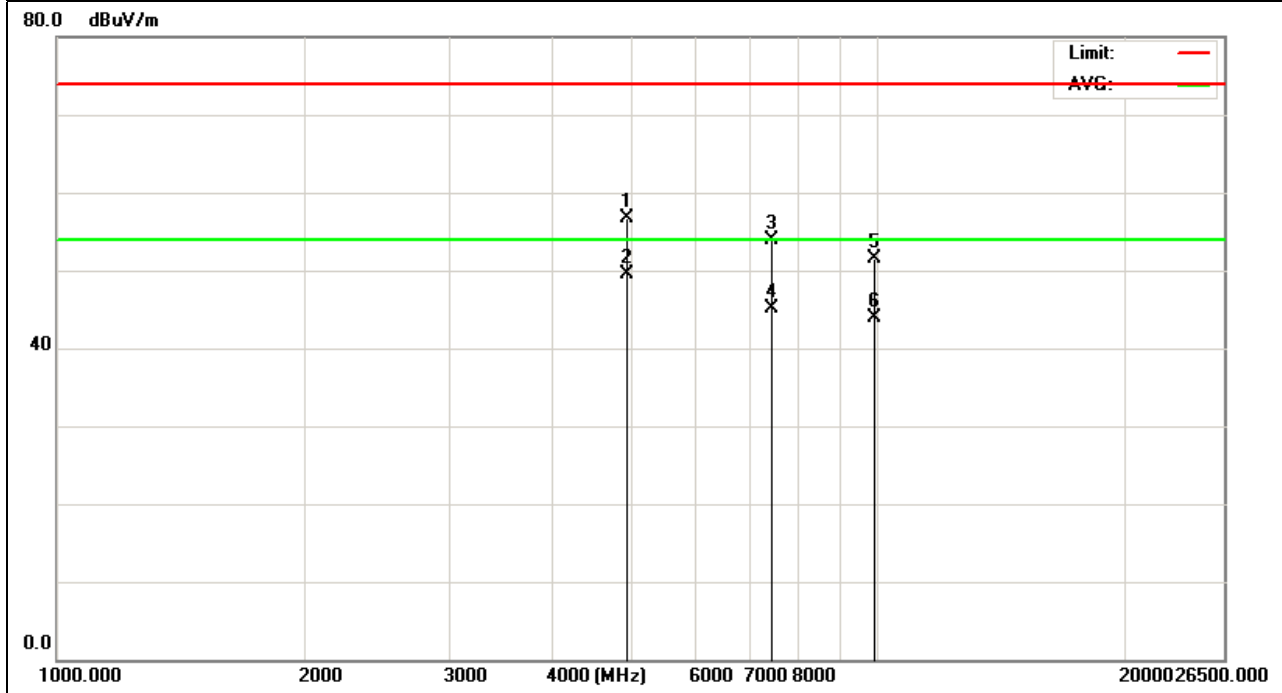

EUT :	Bluetooth Wireless Mouse	Model Name :	iMouse M300W
Temperature :	20 °C	Relative Humidity :	48%
Pressure :	1010 hPa	Test Voltage :	DC 3V
Test Mode :	TX 2480MHz – CH 78(1Mbps)	Polarization :	Vertical

Frequency (MHz)	Meter Reading (dBµV)	Factor (dB)	Emission Level (dBµV/m)	Limits (dBµV/m)	Margin (dB)	Detector Type
4956.68	22.07	35.47	57.54	74	-16.46	peak
4956.68	12.65	35.47	48.12	54	-5.88	AVG
7434.97	19.74	36.7	56.44	74	-17.56	peak
7434.97	8.8	36.7	45.5	54	-8.5	AVG
9920.11	14.3	37.73	52.03	74	-21.97	peak
9920.11	5.17	37.73	42.9	54	-11.1	AVG

Remark:
Factor = Antenna Factor + Cable Loss – Pre-amplifier.

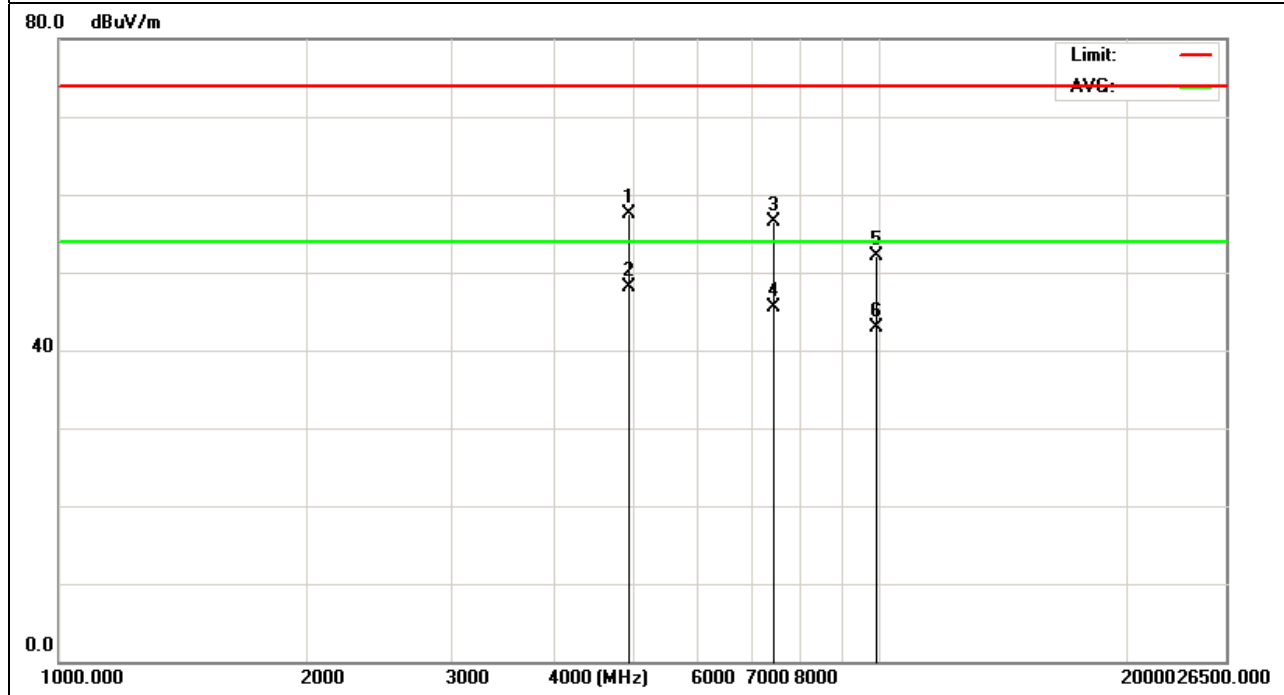

EUT :	Bluetooth Wireless Mouse	Model Name :	iMouse M300W
Temperature :	20 °C	Relative Humidity :	48%
Pressure :	1010 hPa	Test Voltage :	DC 3V
Test Mode :	TX 2402MHz – CH 00(2Mbps)	Polarization :	Horizontal

Frequency (MHz)	Meter Reading (dBµV)	Factor (dB)	Emission Level (dBµV/m)	Limits (dBµV/m)	Margin (dB)	Detector Type
1335.66	27.29	25.43	52.72	74	-21.28	peak
1335.66	18.22	25.43	43.65	54	-10.35	AVG
4804.27	21.34	35.6	56.94	74	-17.06	peak
4804.27	13.25	35.6	48.85	54	-5.15	AVG
7206.6	17.26	36.26	53.52	74	-20.48	peak
7206.6	8.54	36.26	44.8	54	-9.2	AVG
9608.99	16.16	37.93	54.09	74	-19.91	peak
9608.99	7.06	37.93	44.99	54	-9.01	AVG

Remark:
Factor = Antenna Factor + Cable Loss – Pre-amplifier.

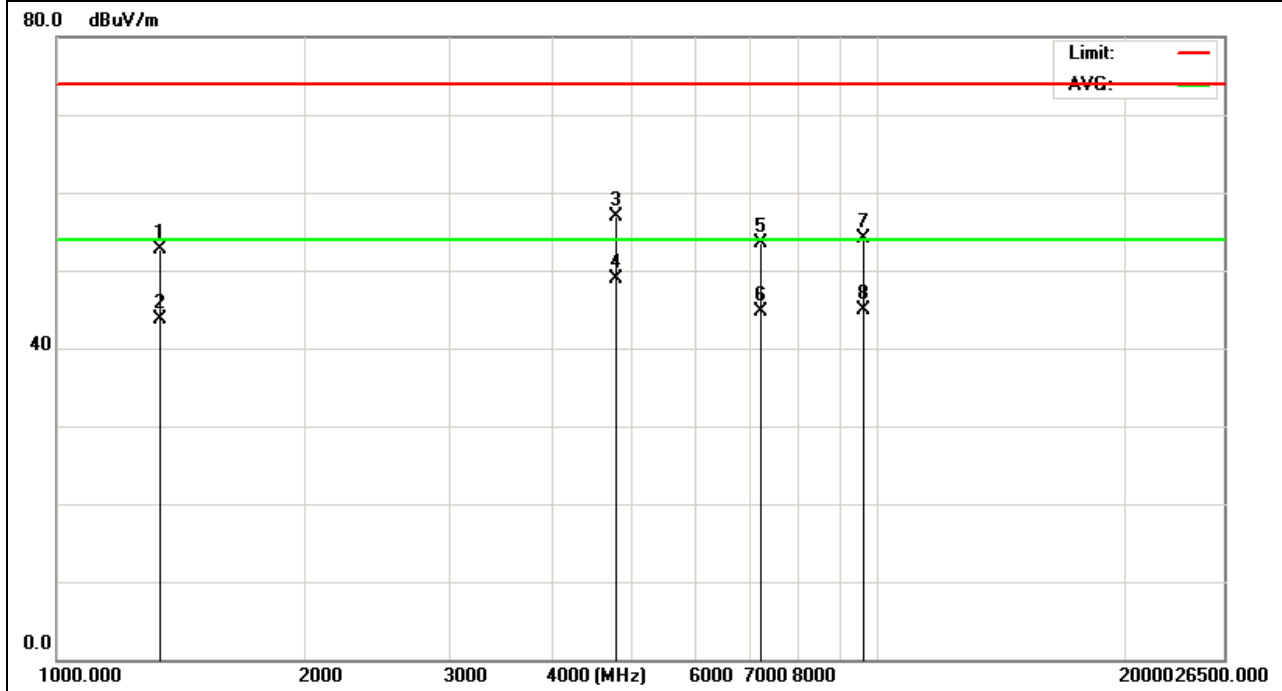

EUT :	Bluetooth Wireless Mouse	Model Name :	iMouse M300W
Temperature :	20 °C	Relative Humidity :	48%
Pressure :	1010 hPa	Test Voltage :	DC 3V
Test Mode :	TX 2402MHz – CH 00(2Mbps)	Polarization :	Vertical

Frequency (MHz)	Meter Reading (dBµV)	Factor (dB)	Emission Level (dBµV/m)	Limits (dBµV/m)	Margin (dB)	Detector Type
1300.25	28.28	25.21	53.49	74	-20.51	peak
1300.25	16.52	25.21	41.73	54	-12.27	AVG
4804.07	22.54	35.6	58.14	74	-15.86	peak
4804.07	14.35	35.6	49.95	54	-4.05	AVG
7206.33	18.37	36.26	54.63	74	-19.37	peak
7206.33	9.35	36.26	45.61	54	-8.39	AVG
9608.62	16.33	37.94	54.27	74	-19.73	peak
9608.62	6.35	37.94	44.29	54	-9.71	AVG

Remark:
Factor = Antenna Factor + Cable Loss – Pre-amplifier.

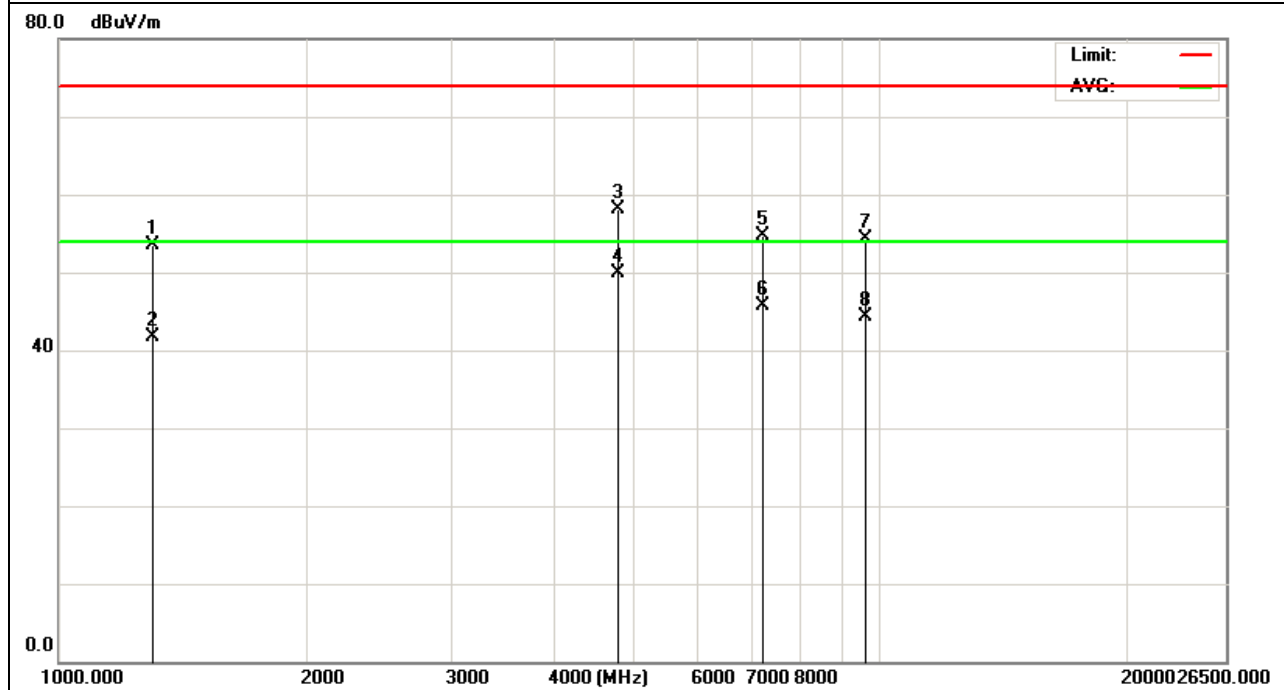

EUT :	Bluetooth Wireless Mouse	Model Name :	iMouse M300W
Temperature :	20 °C	Relative Humidity :	48%
Pressure :	1010 hPa	Test Voltage :	DC 3V
Test Mode :	TX 2441MHz – CH 39(2Mbps)	Polarization :	Horizontal

Frequency (MHz)	Meter Reading (dBµV)	Factor (dB)	Emission Level (dBµV/m)	Limits (dBµV/m)	Margin (dB)	Detector Type
4882.22	22.51	35.46	57.97	74	-16.03	peak
4882.75	12.7	35.46	48.16	54	-5.84	AVG
7323.21	21.37	36.51	57.88	74	-16.12	peak
7323.21	10.16	36.51	46.67	54	-7.33	AVG
9764.33	15.27	37.01	52.28	74	-21.72	peak
9764.33	7.03	37.01	44.04	54	-9.96	AVG

Remark:
 Factor = Antenna Factor + Cable Loss – Pre-amplifier.

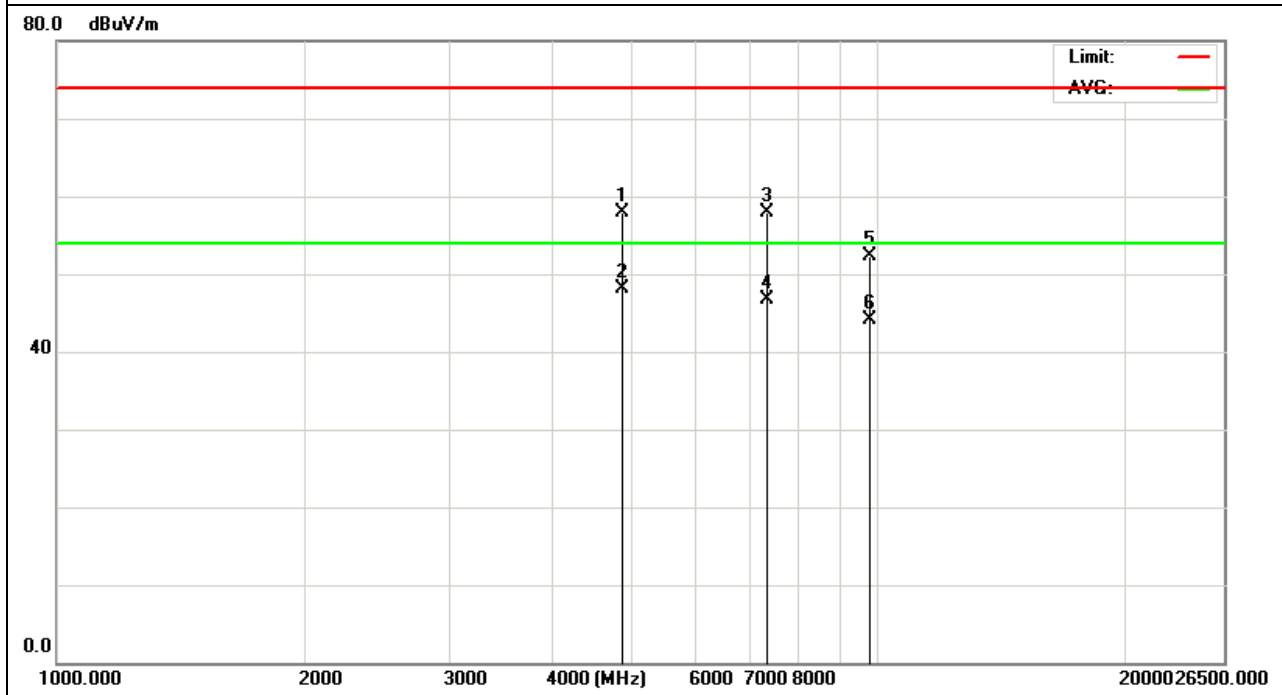

EUT :	Bluetooth Wireless Mouse	Model Name :	iMouse M300W
Temperature :	20 °C	Relative Humidity :	48%
Pressure :	1010 hPa	Test Voltage :	DC 3V
Test Mode :	TX 2441MHz – CH 39(2Mbps)	Polarization :	Vertical

Frequency (MHz)	Meter Reading (dBµV)	Factor (dB)	Emission Level (dBµV/m)	Limits (dBµV/m)	Margin (dB)	Detector Type
4882.55	23.2	35.46	58.66	74	-15.34	peak
4882.55	13.6	35.46	49.06	54	-4.94	AVG
7322.36	19.02	36.51	55.53	74	-18.47	peak
7322.36	10.1	36.51	46.61	54	-7.39	AVG
9764.47	15.35	37.01	52.36	74	-21.64	peak
9764.47	6.74	37.01	43.75	54	-10.25	AVG

Remark:
Factor = Antenna Factor + Cable Loss – Pre-amplifier.

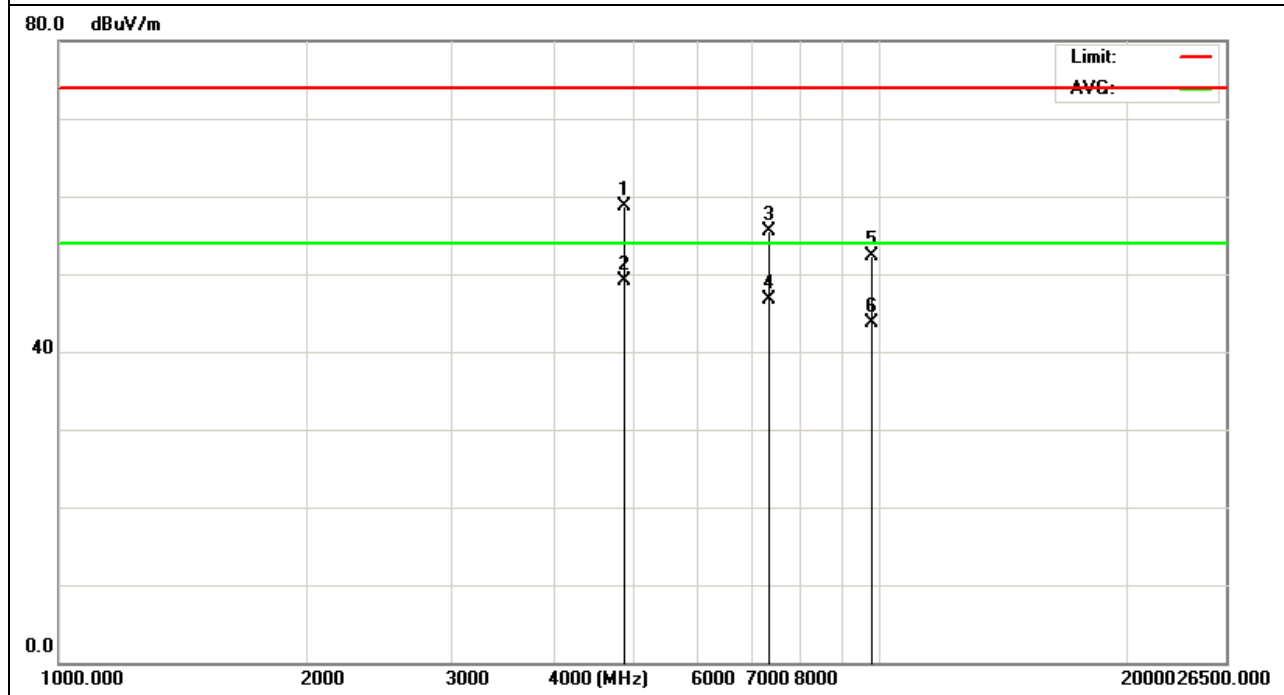

EUT :	Bluetooth Wireless Mouse	Model Name :	iMouse M300W
Temperature :	20 °C	Relative Humidity :	48%
Pressure :	1010 hPa	Test Voltage :	DC 3V
Test Mode :	TX 2480MHz – CH 78(2Mbps)	Polarization :	Horizontal

Frequency (MHz)	Meter Reading (dBµV)	Factor (dB)	Emission Level (dBµV/m)	Limits (dBµV/m)	Margin (dB)	Detector Type
4954.62	22.78	35.49	58.27	74	-15.73	peak
4954.62	13.65	35.49	49.14	54	-4.86	AVG
7431.85	20.49	36.66	57.15	74	-16.85	peak
7431.85	9.85	36.66	46.51	54	-7.49	AVG
9908.16	16.28	37.52	53.8	74	-20.2	peak
9908.16	7.34	37.52	44.86	54	-9.14	AVG

Remark:
Factor = Antenna Factor + Cable Loss – Pre-amplifier.

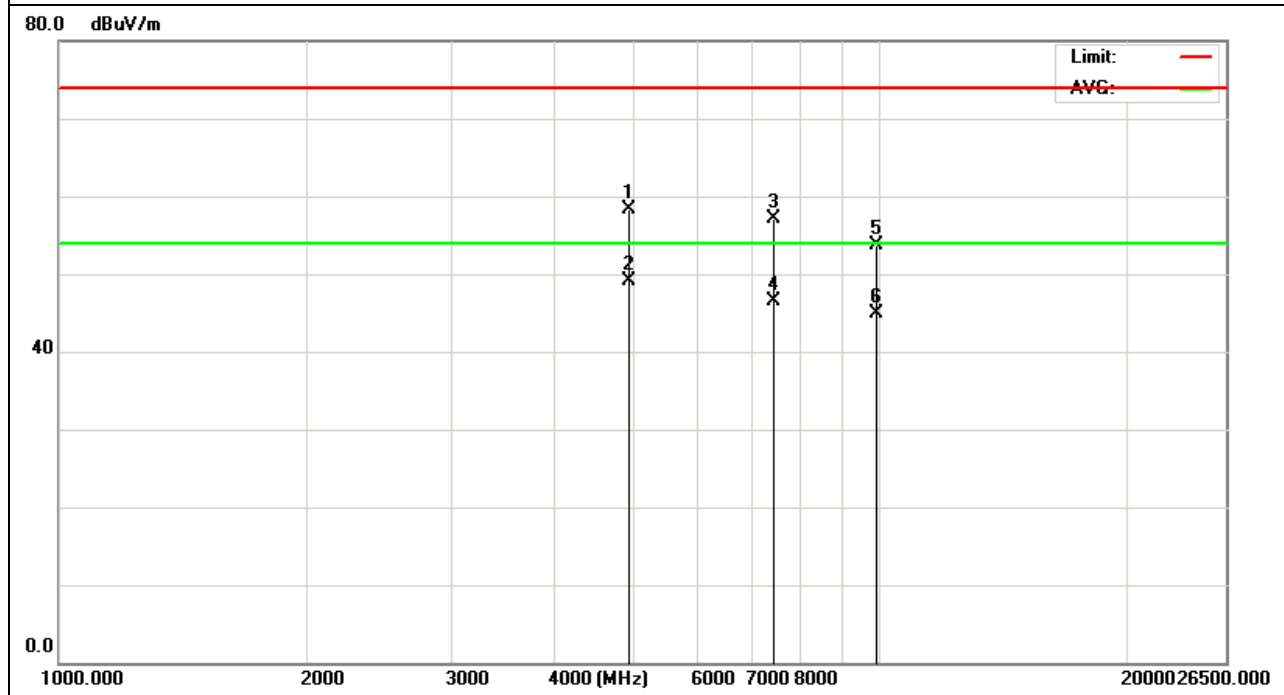

EUT :	Bluetooth Wireless Mouse	Model Name :	iMouse M300W
Temperature :	20 °C	Relative Humidity :	48%
Pressure :	1010 hPa	Test Voltage :	DC 3V
Test Mode :	TX 2480MHz – CH 78(2Mbps)	Polarization :	Vertical

Frequency (MHz)	Meter Reading (dBµV)	Factor (dB)	Emission Level (dBµV/m)	Limits (dBµV/m)	Margin (dB)	Detector Type
4956.17	22.67	35.48	58.15	74	-15.85	peak
4956.17	13.7	35.48	49.18	54	-4.82	AVG
7434.56	19.15	36.69	55.84	74	-18.16	peak
7434.56	8.85	36.69	45.54	54	-8.46	AVG
9920.31	14.26	37.74	52	74	-22	peak
9920.31	6.23	37.74	43.97	54	-10.03	AVG

Remark:
Factor = Antenna Factor + Cable Loss – Pre-amplifier.

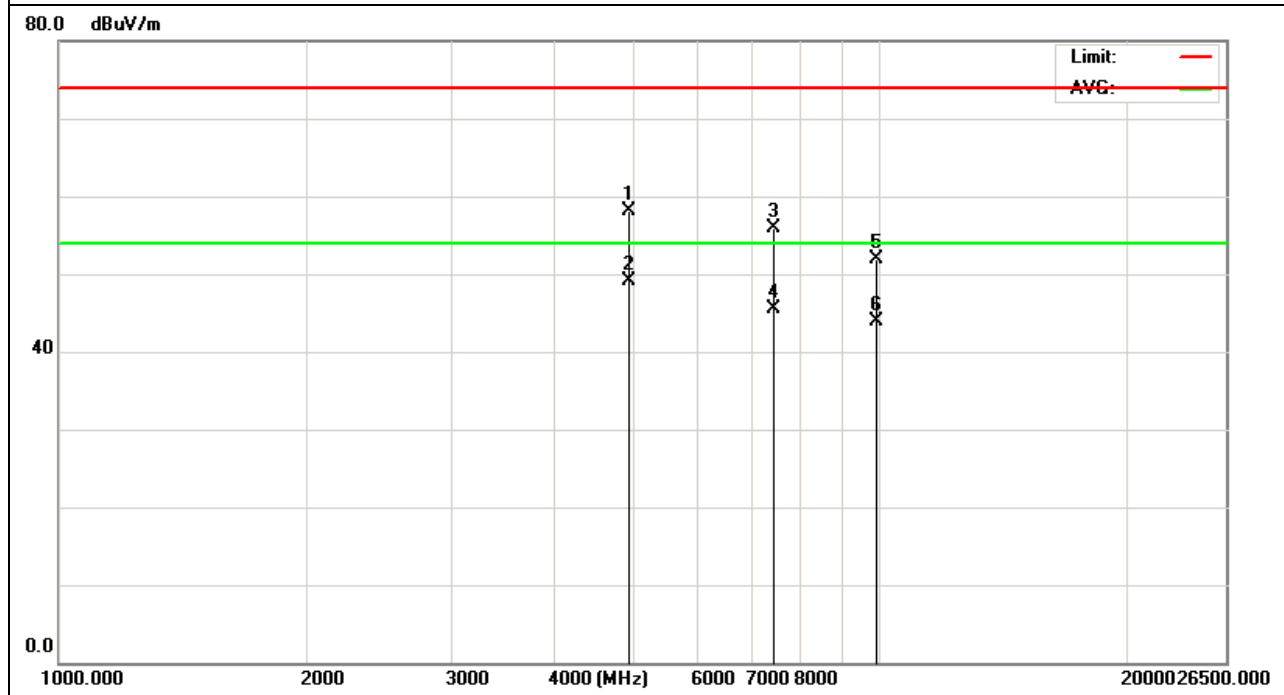

EUT :	Bluetooth Wireless Mouse	Model Name :	iMouse M300W
Temperature :	20 °C	Relative Humidity :	48%
Pressure :	1010 hPa	Test Voltage :	DC 3V
Test Mode :	TX 2402MHz – CH00 (3Mbps)	Polarization :	Horizontal

Frequency (MHz)	Meter Reading (dBµV)	Factor (dB)	Emission Level (dBµV/m)	Limits (dBµV/m)	Margin (dB)	Detector Type
1205.2	29.21	25.41	54.62	74	-19.38	peak
1205.2	16.35	25.41	41.76	54	-12.24	AVG
4804.25	23.17	35.6	58.77	74	-15.23	peak
4804.25	16.52	35.6	52.12	54	-1.88	AVG
7206.26	10.37	36.26	46.63	54	-7.37	AVG
7206.47	20.97	36.26	57.23	74	-16.77	peak
9608.5	16.07	37.94	54.01	74	-19.99	peak
9608.5	7.57	37.94	45.51	54	-8.49	AVG

Remark:
 Factor = Antenna Factor + Cable Loss – Pre-amplifier.

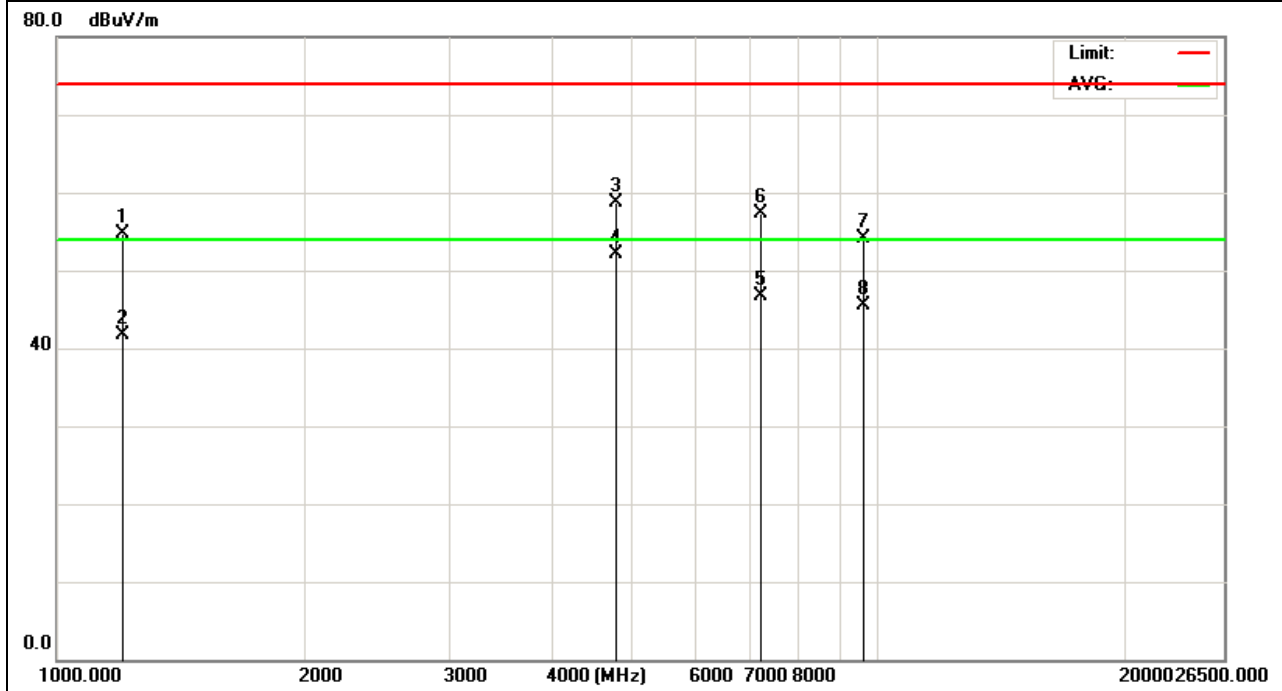

EUT :	Bluetooth Wireless Mouse	Model Name :	iMouse M300W
Temperature :	20 °C	Relative Humidity :	48%
Pressure :	1010 hPa	Test Voltage :	DC 3V
Test Mode :	TX 2402MHz – CH00 (3Mbps)	Polarization :	Vertical

Frequency (MHz)	Meter Reading (dBµV)	Factor (dB)	Emission Level (dBµV/m)	Limits (dBµV/m)	Margin (dB)	Detector Type
1335.1	27.2	25.43	52.63	74	-21.37	peak
1335.11	15.34	25.43	40.77	54	-13.23	AVG
4804.32	23.55	35.6	59.15	74	-14.85	peak
4804.32	14.36	35.6	49.96	54	-4.04	AVG
7206.38	21.17	36.26	57.43	74	-16.57	peak
7206.38	12.13	36.26	48.39	54	-5.61	AVG
9608.71	17.33	37.94	55.27	74	-18.73	peak
9608.71	8.03	37.94	45.97	54	-8.03	AVG

Remark:
Factor = Antenna Factor + Cable Loss – Pre-amplifier.

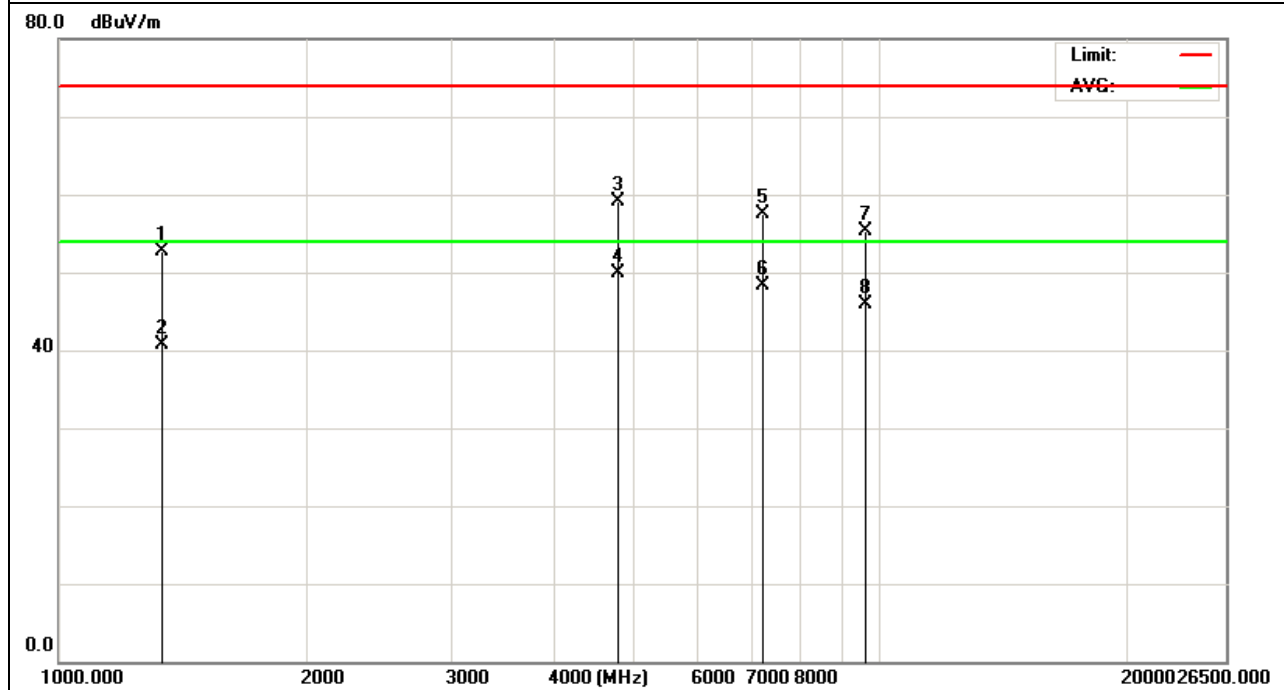

EUT :	Bluetooth Wireless Mouse	Model Name :	iMouse M300W
Temperature :	20 °C	Relative Humidity :	48%
Pressure :	1010 hPa	Test Voltage :	DC 3V
Test Mode :	TX 2441MHz – CH39(3Mbps)	Polarization :	Horizontal

Frequency (MHz)	Meter Reading (dBµV)	Factor (dB)	Emission Level (dBµV/m)	Limits (dBµV/m)	Margin (dB)	Detector Type
4882.2	21.17	35.46	56.63	74	-17.37	peak
4882.2	13.5	35.46	48.96	54	-5.04	AVG
7322.87	18.31	36.51	54.82	74	-19.18	peak
7322.87	8.85	36.51	45.36	54	-8.64	AVG
9764.32	15.32	37.01	52.33	74	-21.67	peak
9764.32	6.9	37.01	43.91	54	-10.09	AVG

Remark:
Factor = Antenna Factor + Cable Loss – Pre-amplifier.

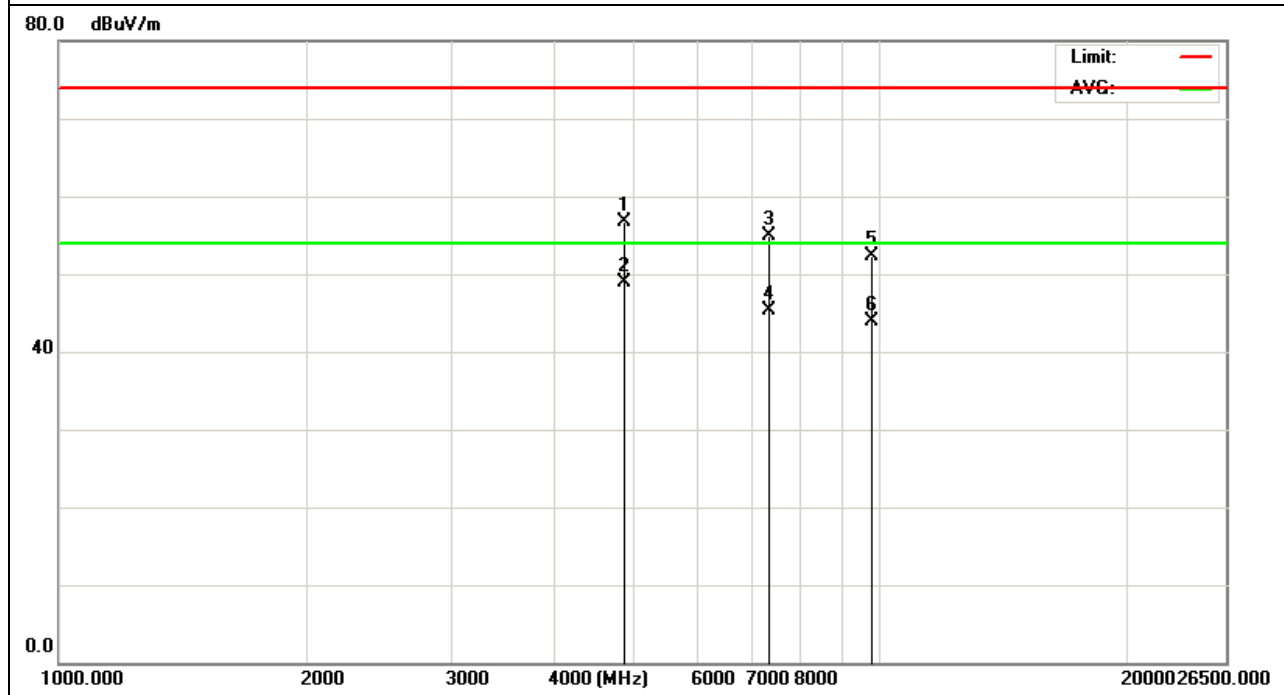

EUT :	Bluetooth Wireless Mouse	Model Name :	iMouse M300W
Temperature :	20 °C	Relative Humidity :	48%
Pressure :	1010 hPa	Test Voltage :	DC 3V
Test Mode :	TX 2441MHz – CH39 (3Mbps)	Polarization :	Vertical

Frequency (MHz)	Meter Reading (dBµV)	Factor (dB)	Emission Level (dBµV/m)	Limits (dBµV/m)	Margin (dB)	Detector Type
4882.06	20.38	35.46	55.84	74	-18.16	peak
4882.06	10.38	35.46	45.84	54	-8.16	AVG
7323.88	16.2	36.51	52.71	74	-21.29	peak
7323.88	8.26	36.51	44.77	54	-9.23	AVG
9764.15	14.81	37.01	51.82	74	-22.18	peak
9764.15	6.27	37.01	43.28	54	-10.72	AVG

Remark:
 Factor = Antenna Factor + Cable Loss – Pre-amplifier.

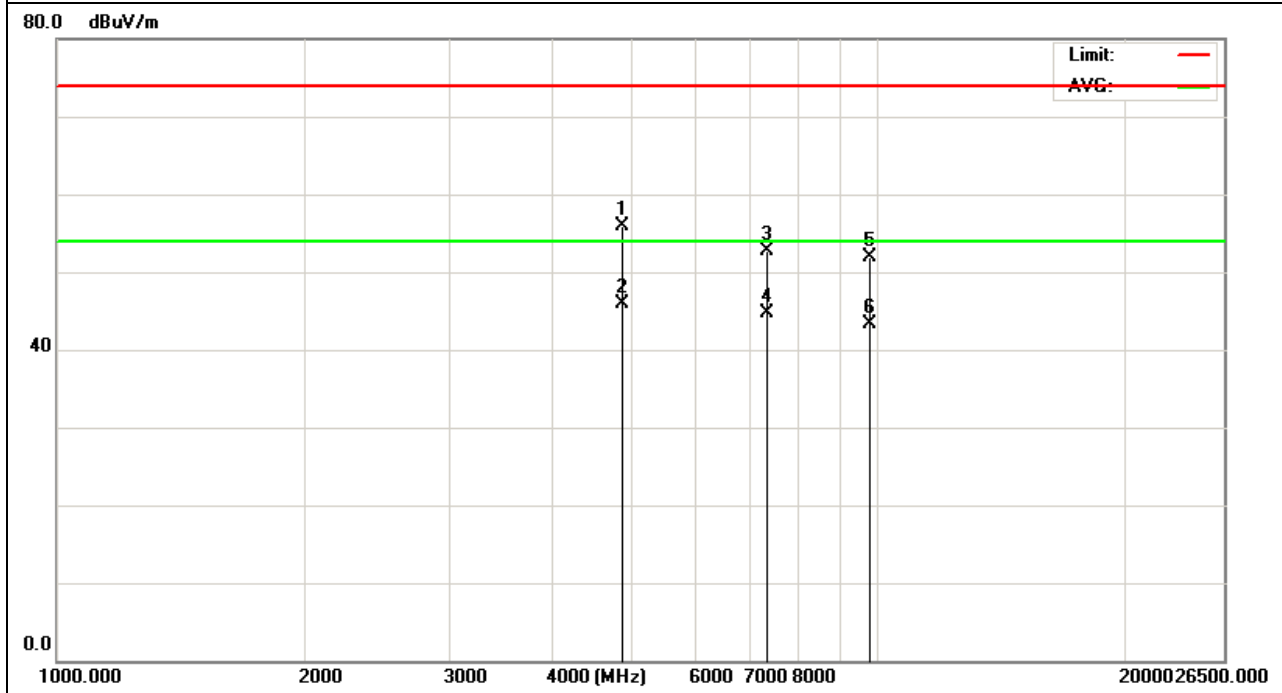

EUT :	Bluetooth Wireless Mouse	Model Name :	iMouse M300W
Temperature :	20 °C	Relative Humidity :	48%
Pressure :	1010 hPa	Test Voltage :	DC 3V
Test Mode :	TX 2480MHz – CH78 (3Mbps)	Polarization :	Horizontal

Frequency (MHz)	Meter Reading (dBµV)	Factor (dB)	Emission Level (dBµV/m)	Limits (dBµV/m)	Margin (dB)	Detector Type
4955.04	22	35.48	57.48	74	-16.52	peak
4955.04	12.51	35.48	47.99	54	-6.01	AVG
7431.15	18.23	36.65	54.88	74	-19.12	peak
7431.15	8.06	36.65	44.71	54	-9.29	AVG
9908.4	15.17	37.53	52.7	74	-21.3	peak
9908.4	6.1	37.53	43.63	54	-10.37	AVG

Remark:
Factor = Antenna Factor + Cable Loss – Pre-amplifier.

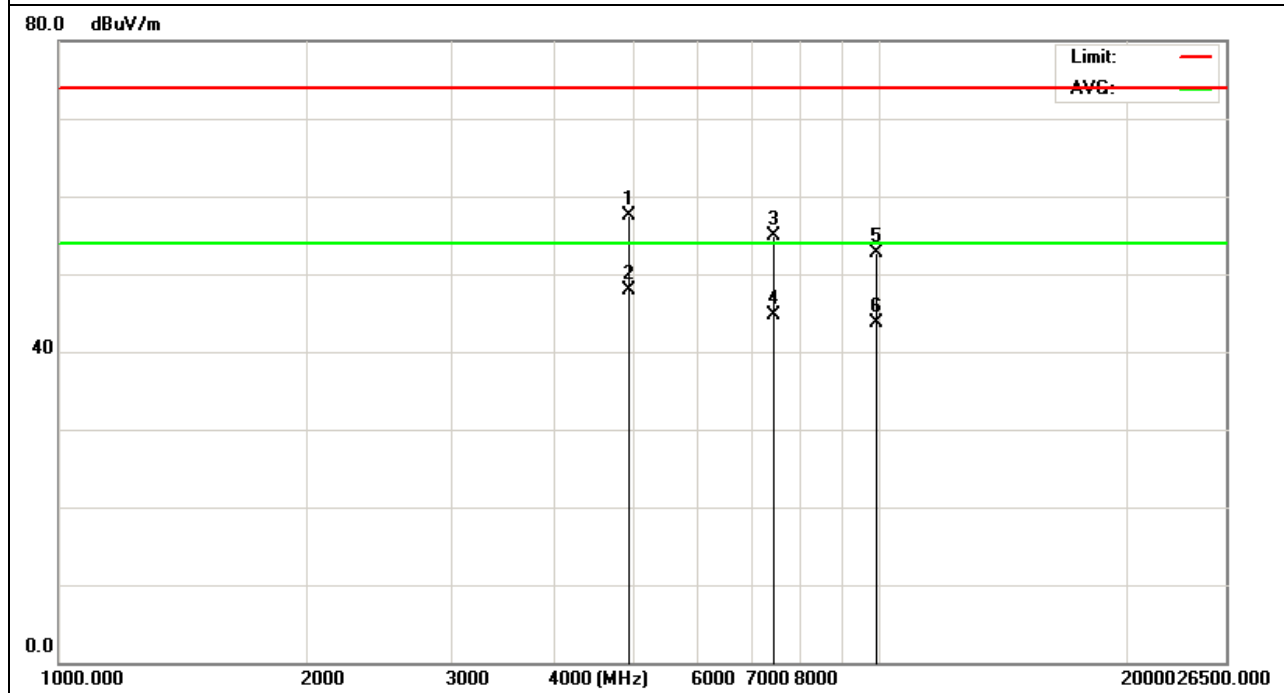

EUT :	Bluetooth Wireless Mouse	Model Name :	iMouse M300W
Temperature :	20 °C	Relative Humidity :	48%
Pressure :	1010 hPa	Test Voltage :	DC 3V
Test Mode :	TX 2480MHz – CH78 (3Mbps)	Polarization :	Vertical

Frequency (MHz)	Meter Reading (dBµV)	Factor (dB)	Emission Level (dBµV/m)	Limits (dBµV/m)	Margin (dB)	Detector Type
4956.87	22.06	35.47	57.53	74	-16.47	peak
4956.87	13.62	35.47	49.09	54	-4.91	AVG
7434.35	17.18	36.69	53.87	74	-20.13	peak
7434.35	7.36	36.69	44.05	54	-9.95	AVG
9920.72	14.15	37.74	51.89	74	-22.11	peak
9920.72	6.15	37.74	43.89	54	-10.11	AVG

Remark:
Factor = Antenna Factor + Cable Loss – Pre-amplifier.

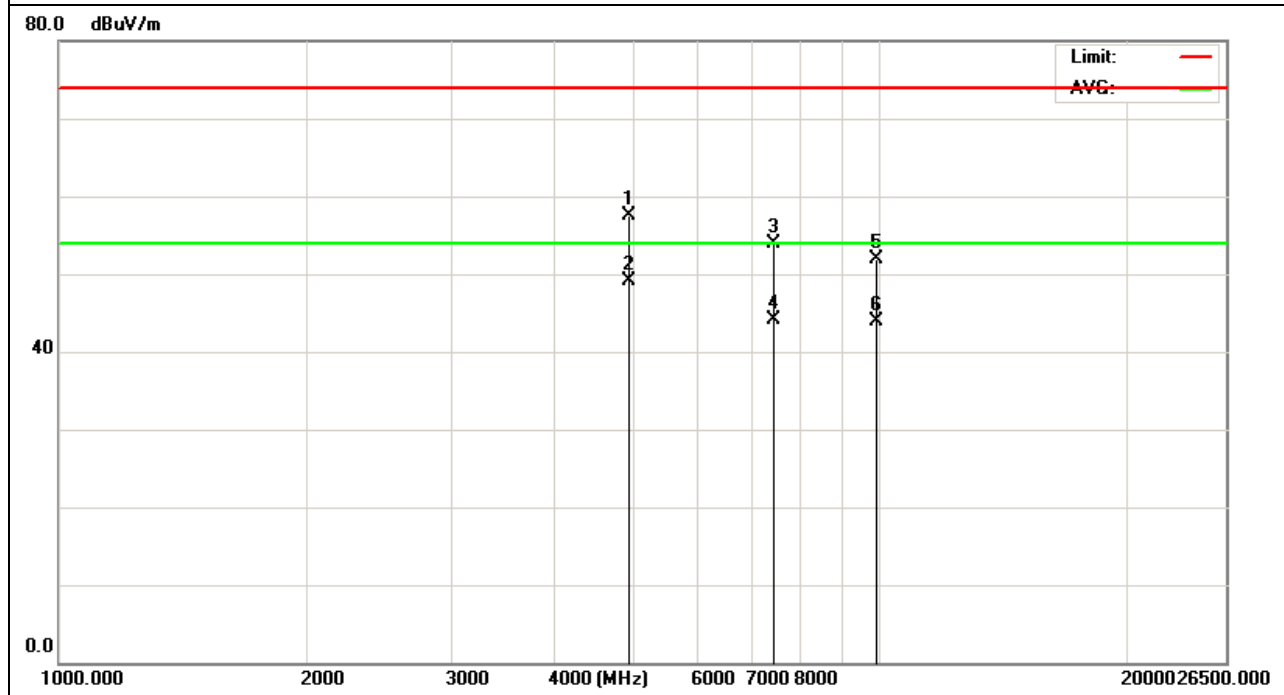

3.2.9 TEST RESULTS (RESTRICTED BANDS REQUIREMENTS)

EUT :	Bluetooth Wireless Mouse	Model Name :	iMouse M300W
Temperature :	20 °C	Relative Humidity :	48%
Pressure :	1010 hPa	Test Voltage :	DC 3V
Test Mode :	TX /2402MHz-1Mbps	Polarization :	Vertical

Frequency (MHz)	Meter Reading (dBμV)	Factor (dB)	Emission Level (dBμV/m)	Limits (dBμV/m)	Margin (dB)	Detector Type
2400	84.7	-40.5	44.2	74	-29.8	peak

Remark:
Factor = Antenna Factor + Cable Loss – Pre-amplifier.

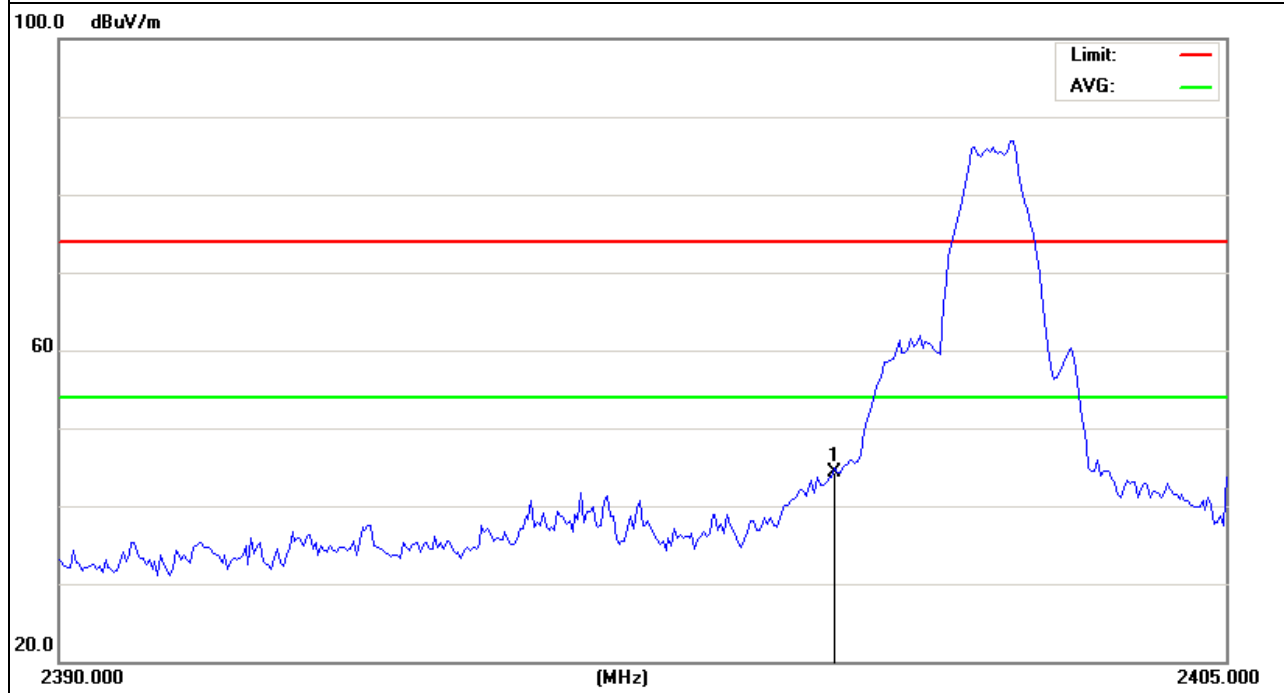

EUT :	Bluetooth Wireless Mouse	Model Name :	iMouse M300W
Temperature :	20 °C	Relative Humidity :	48%
Pressure :	1010 hPa	Test Voltage :	DC 3V
Test Mode :	TX /2402MHz-1Mbps	Polarization :	Horizontal

Frequency (MHz)	Meter Reading (dBµV)	Factor (dB)	Emission Level (dBµV/m)	Limits (dBµV/m)	Margin (dB)	Detector Type
2400	85.59	-40.5	45.09	74	-28.91	peak

Remark:
Factor = Antenna Factor + Cable Loss – Pre-amplifier.

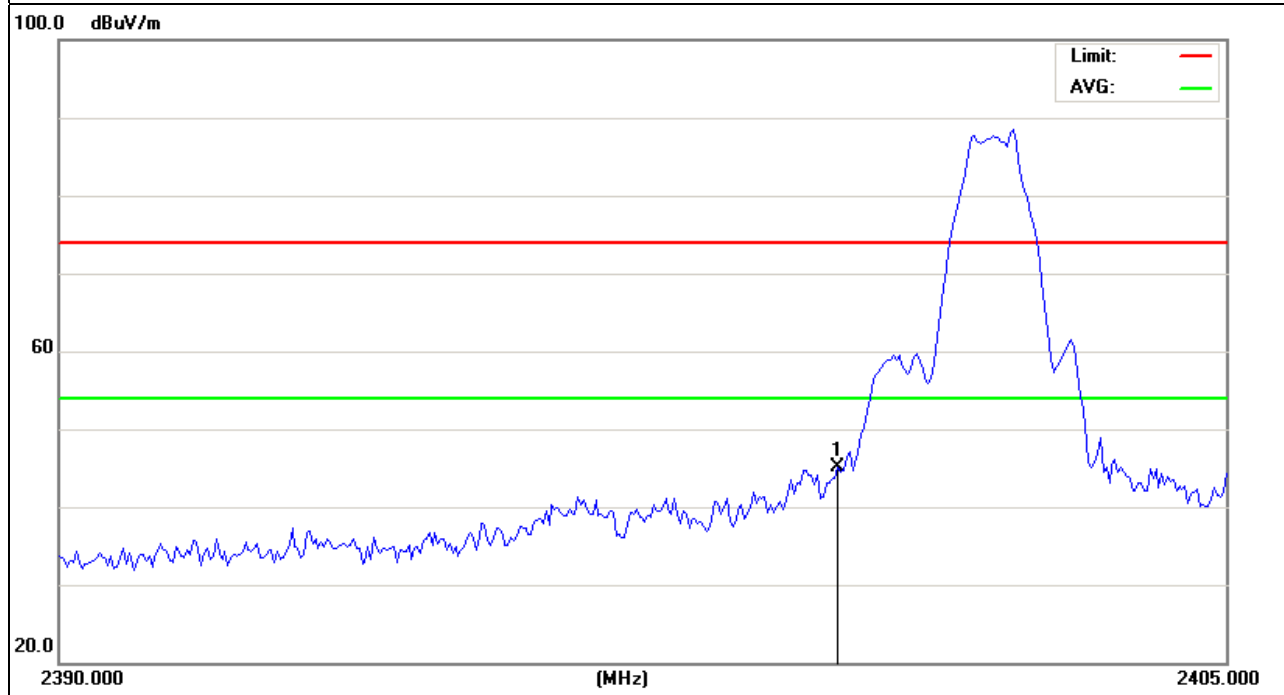

EUT :	Bluetooth Wireless Mouse	Model Name :	iMouse M300W
Temperature :	20 °C	Relative Humidity :	48%
Pressure :	1010 hPa	Test Voltage :	DC 3V
Test Mode :	TX /2480MHz-1Mbps	Polarization :	Vertical

Frequency (MHz)	Meter Reading (dBµV)	Factor (dB)	Emission Level (dBµV/m)	Limits (dBµV/m)	Margin (dB)	Detector Type
2483.5	85.09	-40.43	44.66	74	-29.34	peak

Remark:
Factor = Antenna Factor + Cable Loss – Pre-amplifier.

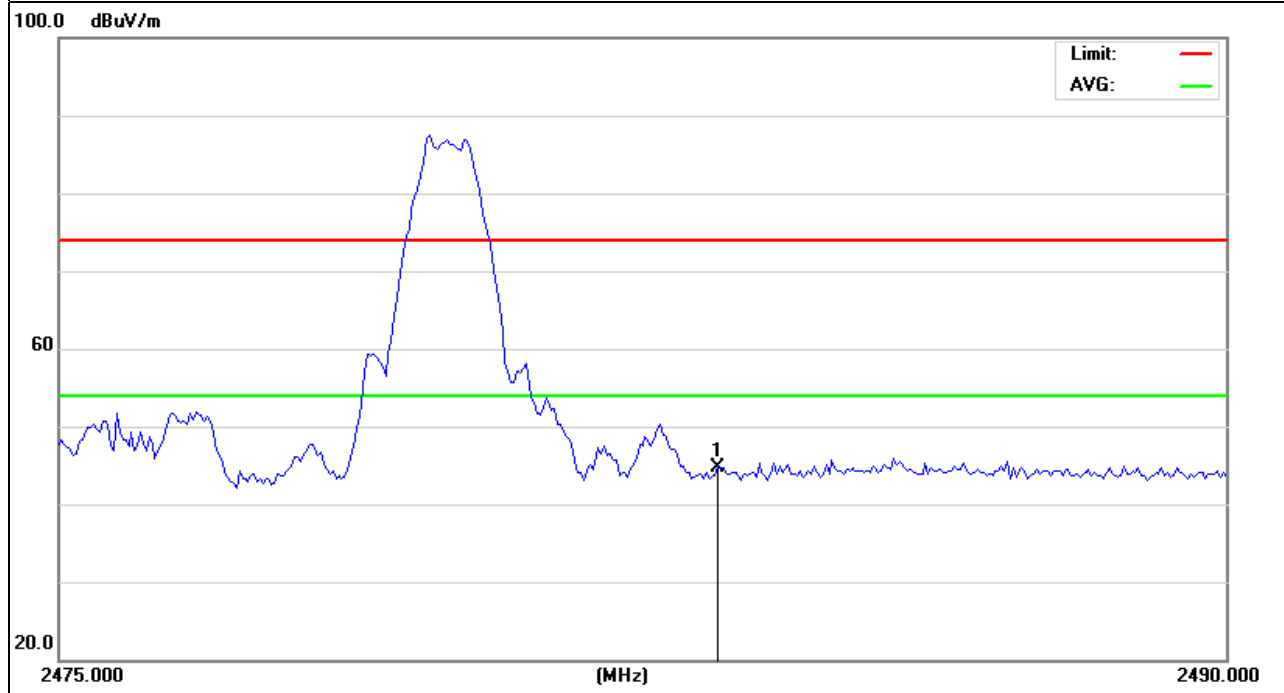

EUT :	Bluetooth Wireless Mouse	Model Name :	iMouse M300W
Temperature :	20 °C	Relative Humidity :	48%
Pressure :	1010 hPa	Test Voltage :	DC 3V
Test Mode :	TX /2480MHz-1Mbps	Polarization :	Horizontal

Frequency (MHz)	Meter Reading (dBµV)	Factor (dB)	Emission Level (dBµV/m)	Limits (dBµV/m)	Margin (dB)	Detector Type
2483.5	85.09	-40.43	44.66	74	-29.34	peak

Remark:
Factor = Antenna Factor + Cable Loss – Pre-amplifier.

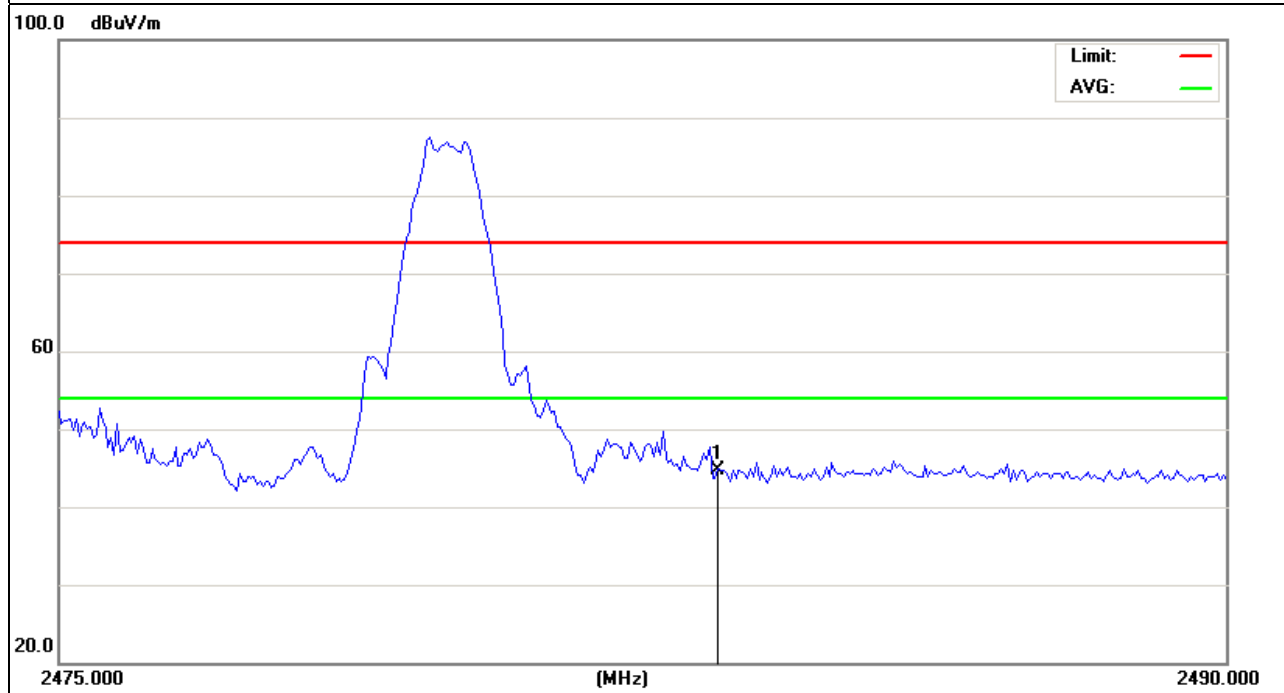

EUT :	Bluetooth Wireless Mouse	Model Name :	iMouse M300W
Temperature :	20 °C	Relative Humidity :	48%
Pressure :	1010 hPa	Test Voltage :	DC 3V
Test Mode :	TX /2402MHz-2Mbps	Polarization :	Vertical

Frequency (MHz)	Meter Reading (dBµV)	Factor (dB)	Emission Level (dBµV/m)	Limits (dBµV/m)	Margin (dB)	Detector Type
2400	92.41	-40.5	51.91	74	-22.09	peak

Remark:
Factor = Antenna Factor + Cable Loss – Pre-amplifier.

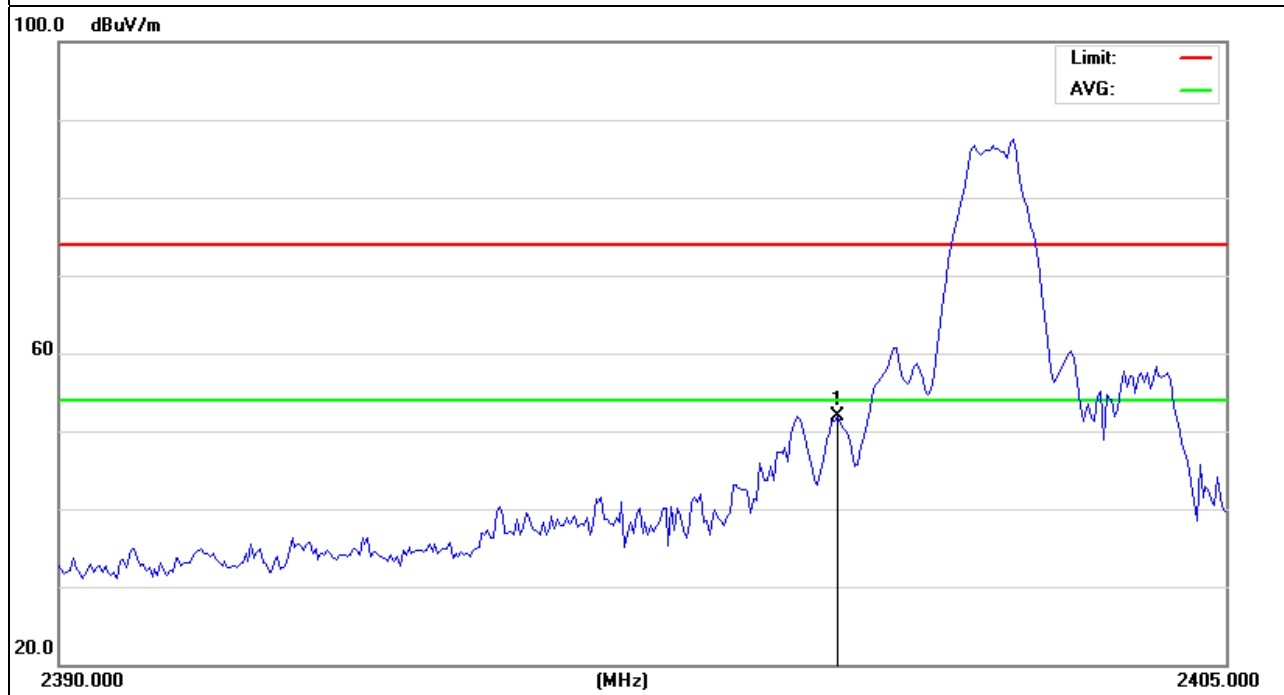

EUT :	Bluetooth Wireless Mouse	Model Name :	iMouse M300W
Temperature :	20 °C	Relative Humidity :	48%
Pressure :	1010 hPa	Test Voltage :	DC 3V
Test Mode :	TX /2402MHz-2Mbps	Polarization :	Horizontal

Frequency (MHz)	Meter Reading (dBµV)	Factor (dB)	Emission Level (dBµV/m)	Limits (dBµV/m)	Margin (dB)	Detector Type
2400	92.09	-40.5	51.59	74	-22.41	peak

Remark:
Factor = Antenna Factor + Cable Loss – Pre-amplifier.

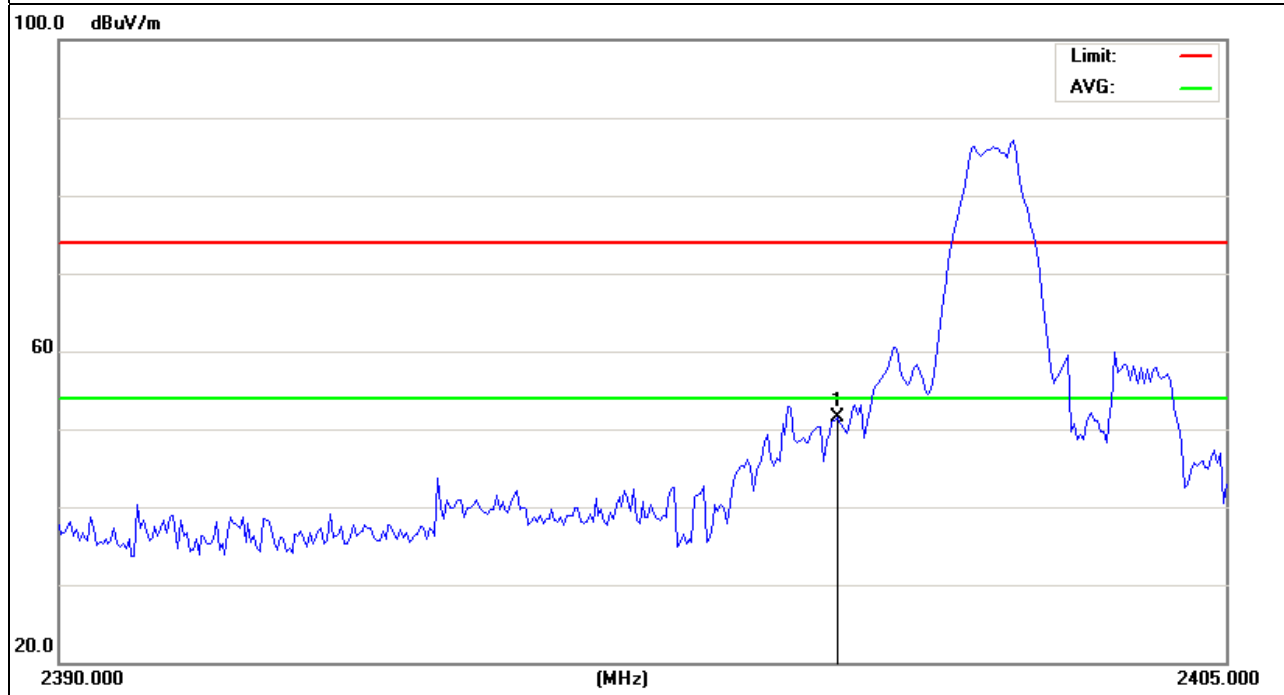

EUT :	Bluetooth Wireless Mouse	Model Name :	iMouse M300W
Temperature :	20 °C	Relative Humidity :	48%
Pressure :	1010 hPa	Test Voltage :	DC 3V
Test Mode :	TX /2480MHz-2Mbps	Polarization :	Vertical

Frequency (MHz)	Meter Reading (dBµV)	Factor (dB)	Emission Level (dBµV/m)	Limits (dBµV/m)	Margin (dB)	Detector Type
2483.5	85.98	-40.43	45.55	74	-28.45	peak

Remark:
Factor = Antenna Factor + Cable Loss – Pre-amplifier.

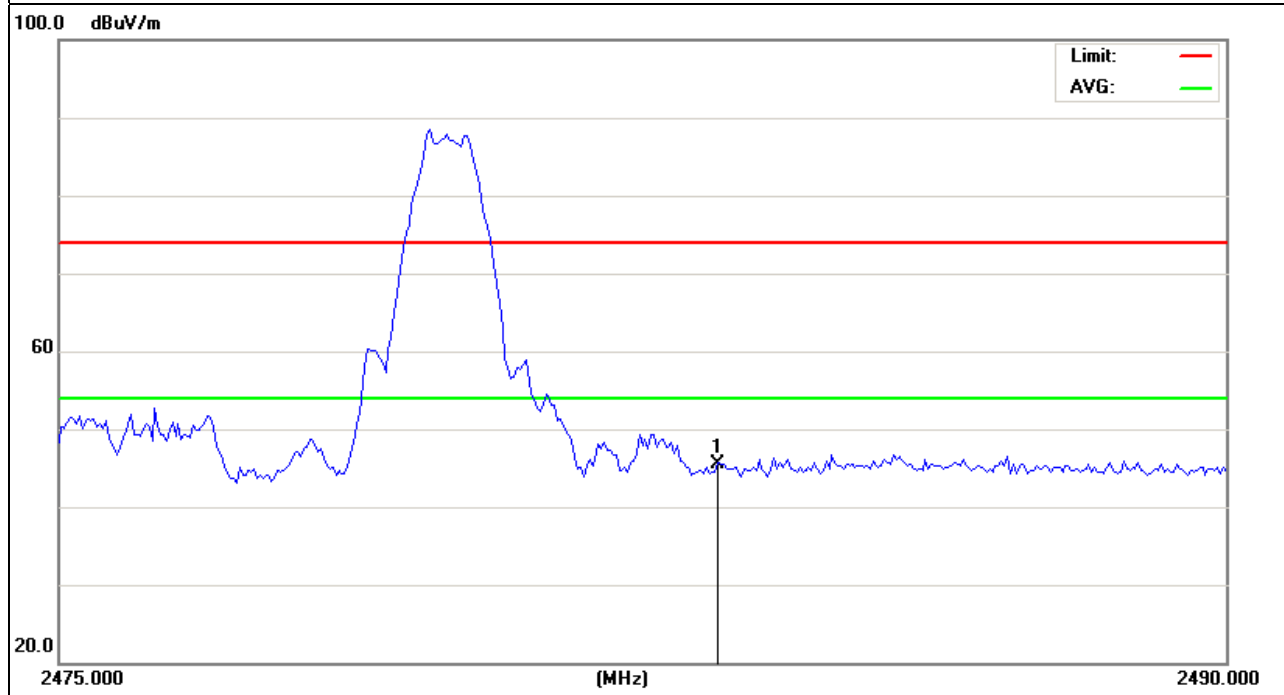

EUT :	Bluetooth Wireless Mouse	Model Name :	iMouse M300W
Temperature :	20 °C	Relative Humidity :	48%
Pressure :	1010 hPa	Test Voltage :	DC 3V
Test Mode :	TX /2480MHz-2Mbps	Polarization :	Horizontal

Frequency (MHz)	Meter Reading (dBµV)	Factor (dB)	Emission Level (dBµV/m)	Limits (dBµV/m)	Margin (dB)	Detector Type
2483.5	85.7	-40.43	45.27	74	-28.73	peak

Remark:
Factor = Antenna Factor + Cable Loss – Pre-amplifier.

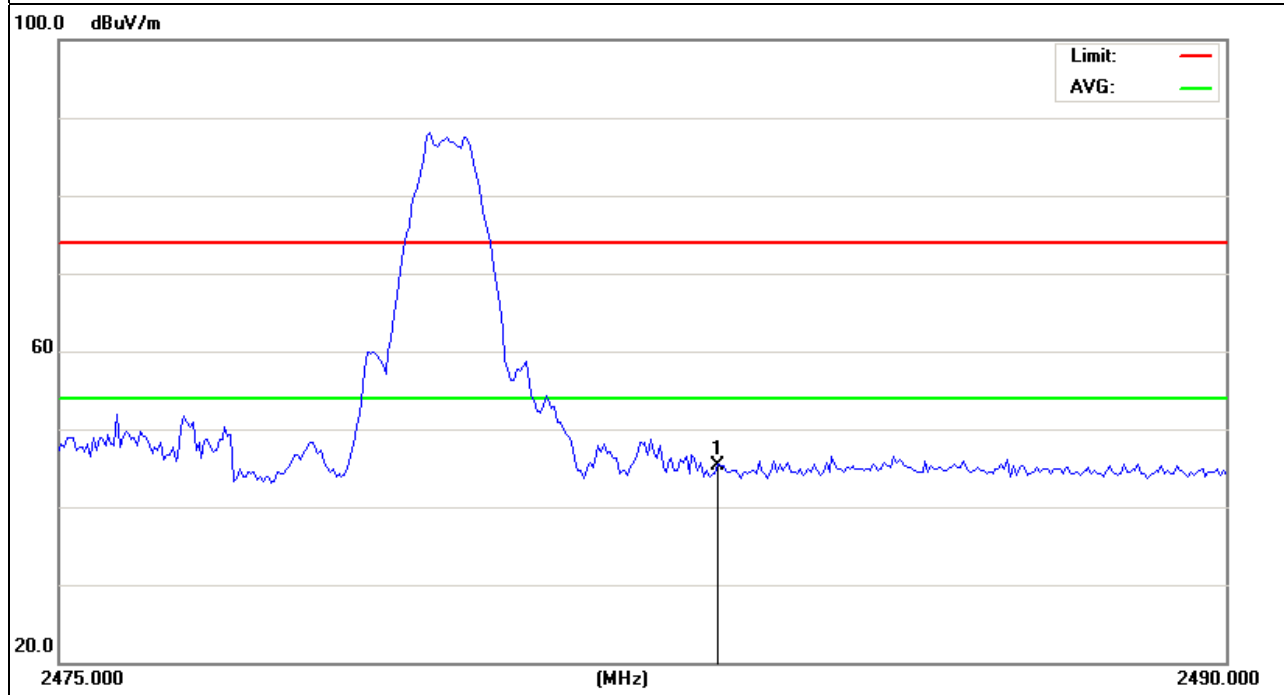

EUT :	Bluetooth Wireless Mouse	Model Name :	iMouse M300W
Temperature :	20 °C	Relative Humidity :	48%
Pressure :	1010 hPa	Test Voltage :	DC 3V
Test Mode :	TX /2402MHz-3Mbps	Polarization :	Vertical

Frequency (MHz)	Meter Reading (dBµV)	Factor (dB)	Emission Level (dBµV/m)	Limits (dBµV/m)	Margin (dB)	Detector Type
2400	93.42	-40.5	52.92	74	-21.08	peak

Remark:
Factor = Antenna Factor + Cable Loss – Pre-amplifier.

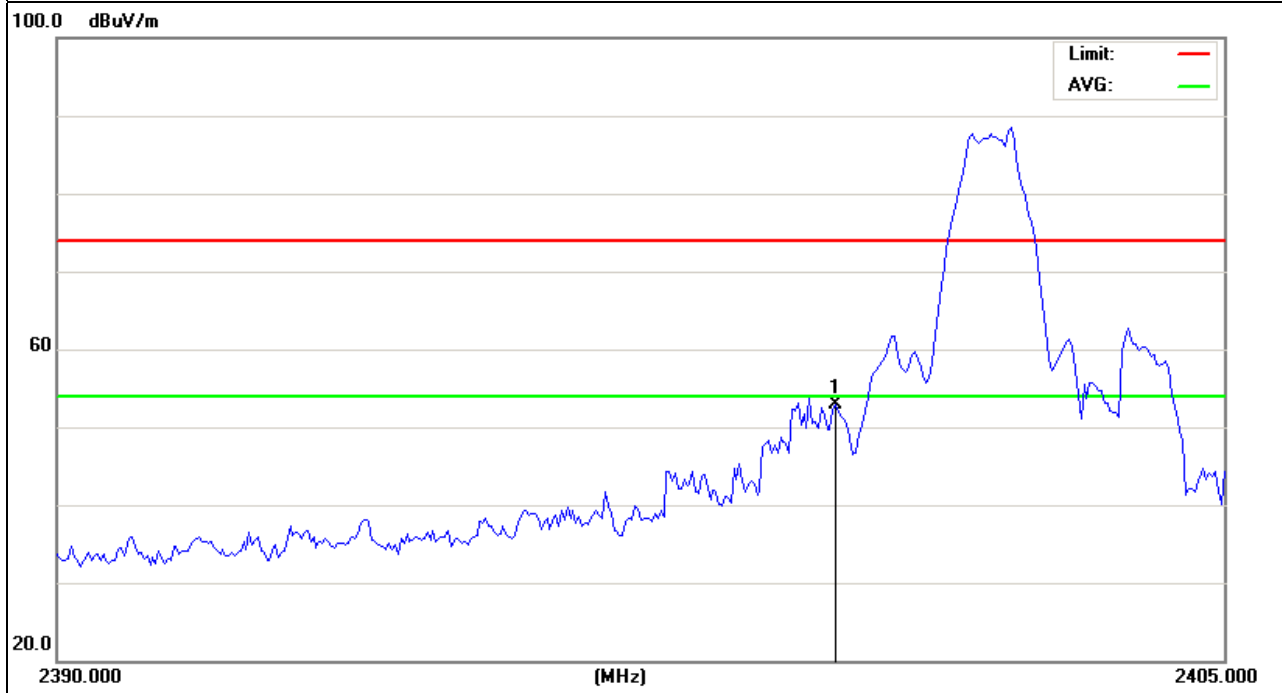

EUT :	Bluetooth Wireless Mouse	Model Name :	iMouse M300W
Temperature :	20 °C	Relative Humidity :	48%
Pressure :	1010 hPa	Test Voltage :	DC 3V
Test Mode :	TX /2402MHz-3Mbps	Polarization :	Horizontal

Frequency (MHz)	Meter Reading (dBµV)	Factor (dB)	Emission Level (dBµV/m)	Limits (dBµV/m)	Margin (dB)	Detector Type
2400	91.3	-40.5	50.8	74	-23.2	peak

Remark:
Factor = Antenna Factor + Cable Loss – Pre-amplifier.

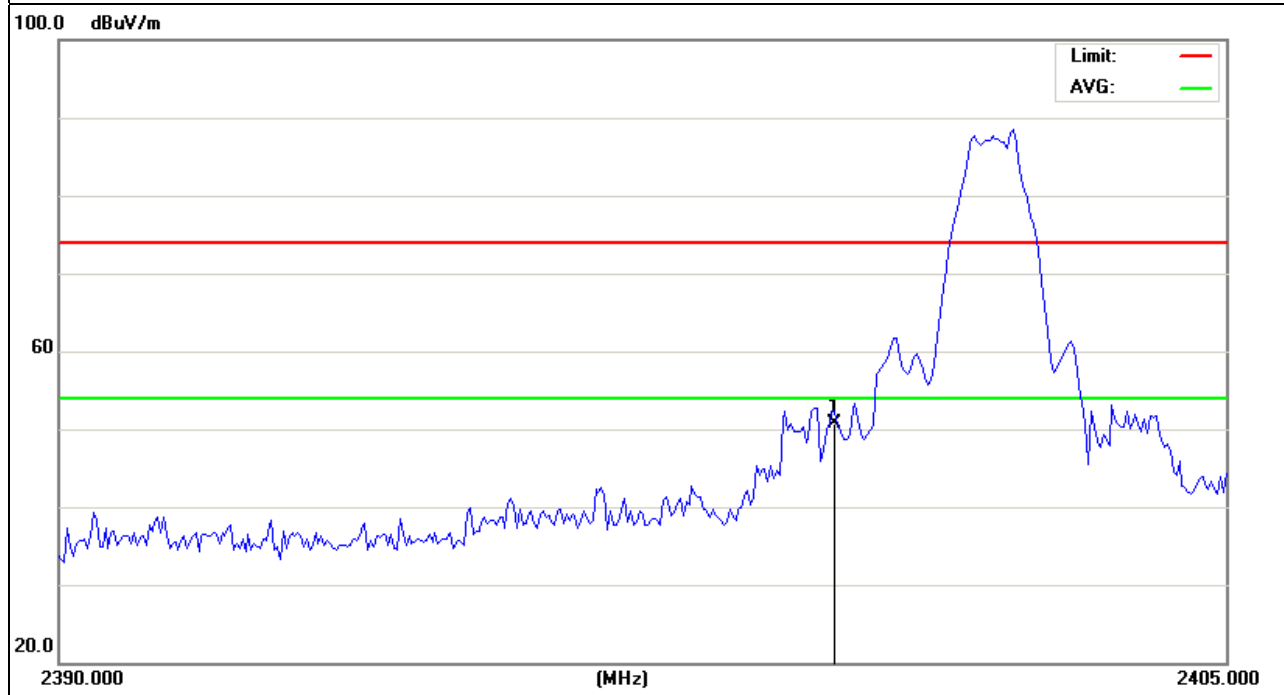

EUT :	Bluetooth Wireless Mouse	Model Name :	iMouse M300W
Temperature :	20 °C	Relative Humidity :	48%
Pressure :	1010 hPa	Test Voltage :	DC 3V
Test Mode :	TX /2480MHz-3Mbps	Polarization :	Vertical

Frequency (MHz)	Meter Reading (dBµV)	Factor (dB)	Emission Level (dBµV/m)	Limits (dBµV/m)	Margin (dB)	Detector Type
2483.5	85.83	-40.43	45.4	74	-28.6	peak

Remark:
Factor = Antenna Factor + Cable Loss – Pre-amplifier.

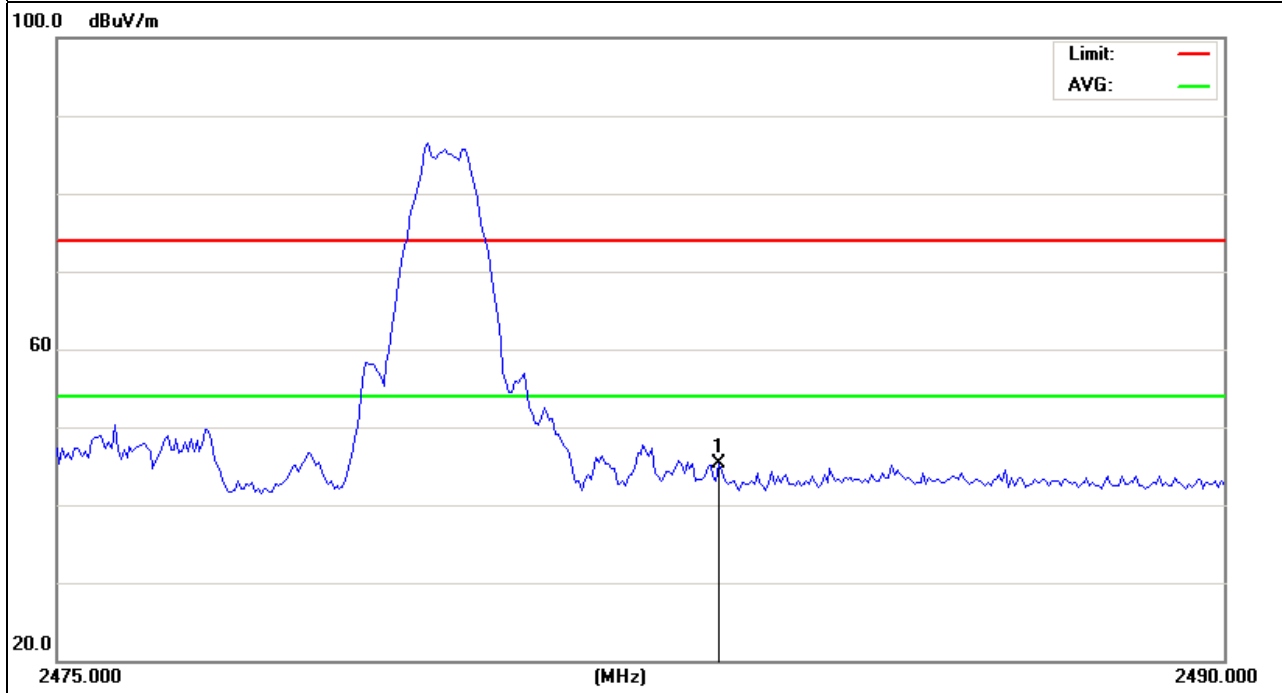

EUT :	Bluetooth Wireless Mouse	Model Name :	iMouse M300W
Temperature :	20 °C	Relative Humidity :	48%
Pressure :	1010 hPa	Test Voltage :	DC 3V
Test Mode :	TX /2480MHz-3Mbps	Polarization :	Horizontal

Frequency (MHz)	Meter Reading (dBµV)	Factor (dB)	Emission Level (dBµV/m)	Limits (dBµV/m)	Margin (dB)	Detector Type
2483.5	82.83	-40.43	42.4	74	-31.6	peak

Remark:
Factor = Antenna Factor + Cable Loss – Pre-amplifier.

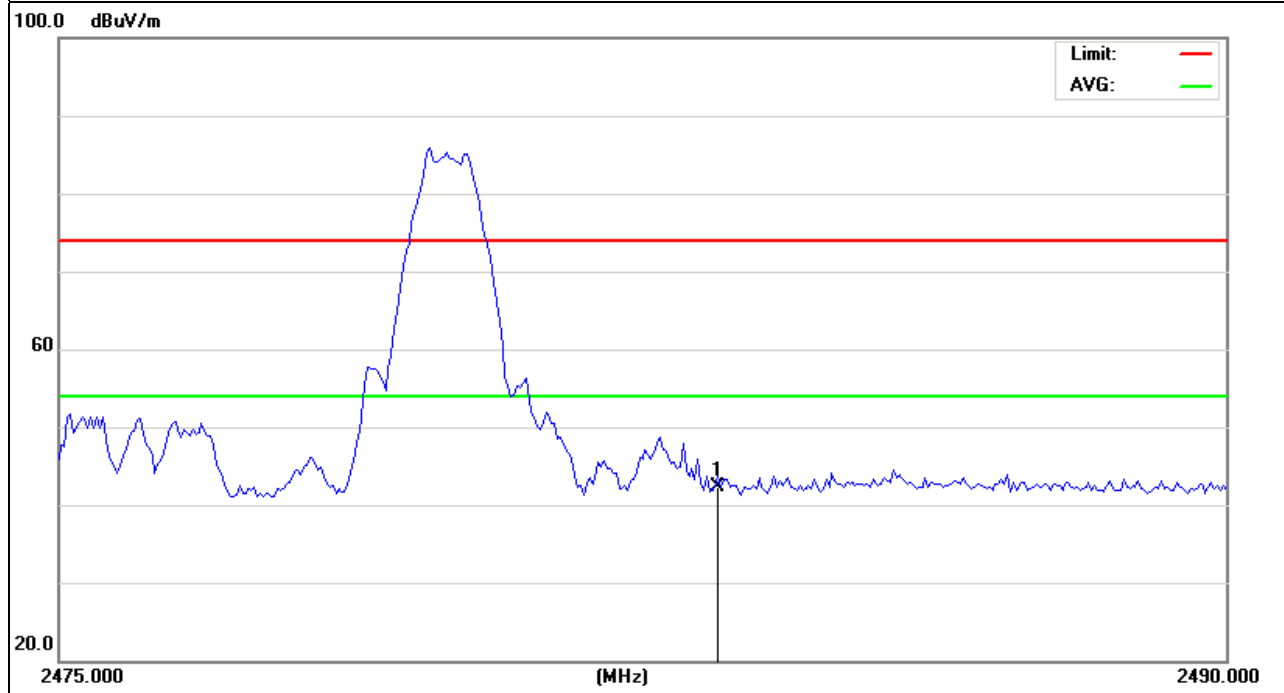

4. NUMBER OF HOPPING CHANNEL

4.1 APPLIED PROCEDURES / LIMIT

FCC Part15 (15.247) , Subpart C				
Section	Test Item	Limit	Frequency Range (MHz)	Result
15.247 (a)(1)(iii)	Number of Hopping Channel	≥15	2400-2483.5	PASS

Spectrum Parameters	Setting
Attenuation	Auto
Span Frequency	> Operating Frequency Range
RB	100 kHz
VB	100 kHz
Detector	Peak
Trace	Max Hold
Sweep Time	Auto

4.1.1 TEST PROCEDURE

- a. The EUT was directly connected to the spectrum analyzer and antenna output port as show in the block diagram below,
- b. Spectrum Setting : RBW= 100KHz, VBW=100KHz, Sweep time = Auto.

4.1.2 DEVIATION FROM STANDARD

No deviation.

4.1.3 TEST SETUP



4.1.4 EUT OPERATION CONDITIONS

The EUT tested system was configured as the statements of 2.4 Unless otherwise a special operating condition is specified in the follows during the testing.

4.1.5 TEST RESULTS

EUT :	Bluetooth Wireless Mouse	Model Name :	iMouse M300W
Temperature :	25 °C	Relative Humidity :	60%
Pressure :	1015 hPa	Test Voltage :	DC 3V
Test Mode :	Hopping Mode		

Number of Hopping Channel	79
---------------------------	----

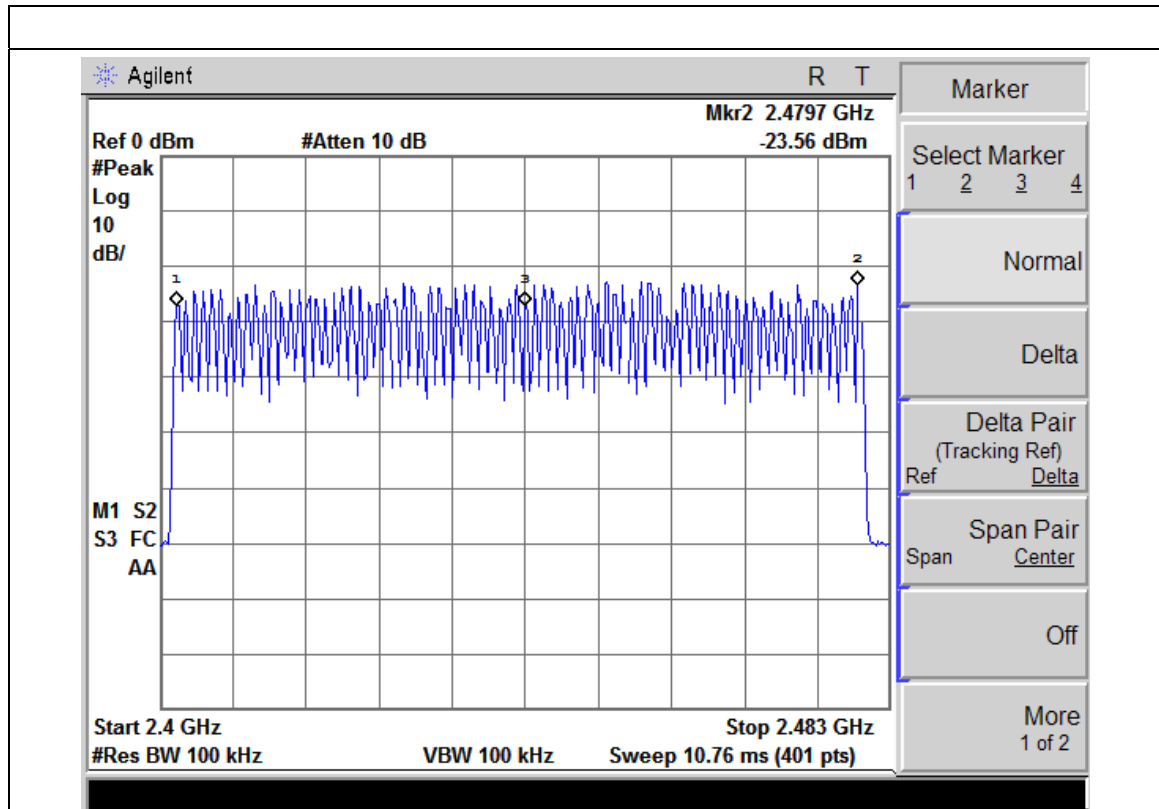

5. AVERAGE TIME OF OCCUPANCY

5.1 APPLIED PROCEDURES / LIMIT

FCC Part15 (15.247) , Subpart C				
Section	Test Item	Limit	Frequency Range (MHz)	Result
15.247 (a)(1)(iii)	Average Time of Occupancy	0.4sec	2400-2483.5	PASS

5.1.1 TEST PROCEDURE

- a. The transmitter output (antenna port) was connected to the spectrum analyzer
- b. Set RBW of spectrum analyzer to 1MHz and VBW to 1MHz.
- c. Use a video trigger with the trigger level set to enable triggering only on full pulses.
- d. Sweep Time is more than once pulse time.
- e. Set the center frequency on any frequency would be measure and set the frequency span to zero span.
- f. Measure the maximum time duration of one single pulse.
- g. Set the EUT for DH5, DH3 and DH1 packet transmitting.
- h. Measure the maximum time duration of one single pulse.
- i. A Period Time = (channel number)*0.4
 DH1 Time Slot: Reading * (1600/2)*31.6/(channel number)
 DH3 Time Slot: Reading * (1600/4)*31.6/(channel number)
 DH5 Time Slot: Reading * (1600/6)*31.6/(channel number)

5.1.2 DEVIATION FROM STANDARD

No deviation.

5.1.3 TEST SETUP

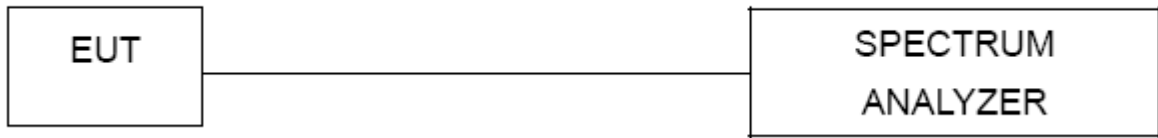

5.1.4 EUT OPERATION CONDITIONS

The EUT tested system was configured as the statements of 2.4 Unless otherwise a special operating condition is specified in the follows during the testing.

5.1.5 TEST RESULTS

EUT :	Bluetooth Wireless Mouse	Model Name :	iMouse M300W
Temperature :	25 °C	Relative Humidity :	60%
Pressure :	1012 hPa	Test Voltage :	DC 3V
Test Mode :	CH39-DH5 ,2DH5,3DH5		

Data packet	frequency (MHz)	pulse duration (ms)	dwel time (s)	limits (s)
HD5	2441	3.05	0.33	0.4
2DH5	2441	3.35	0.36	0.4
3DH5	2441	3	0.32	0.4

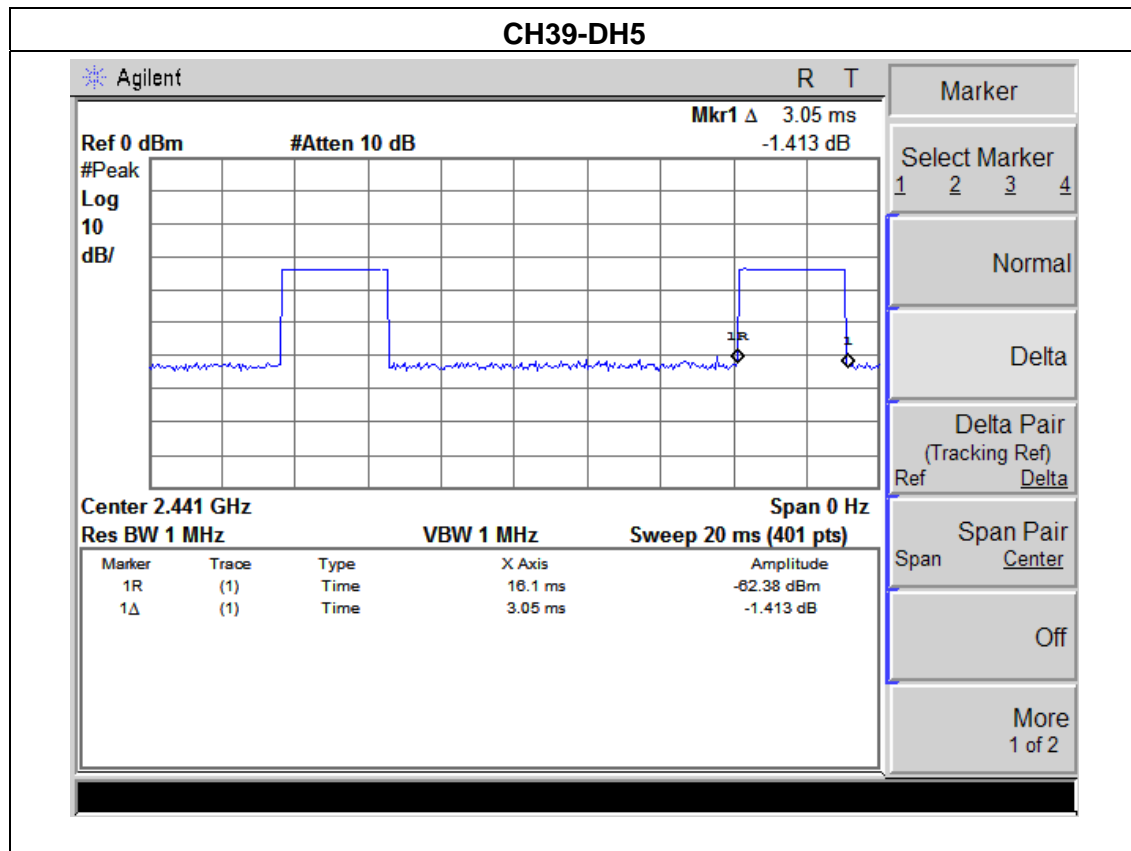

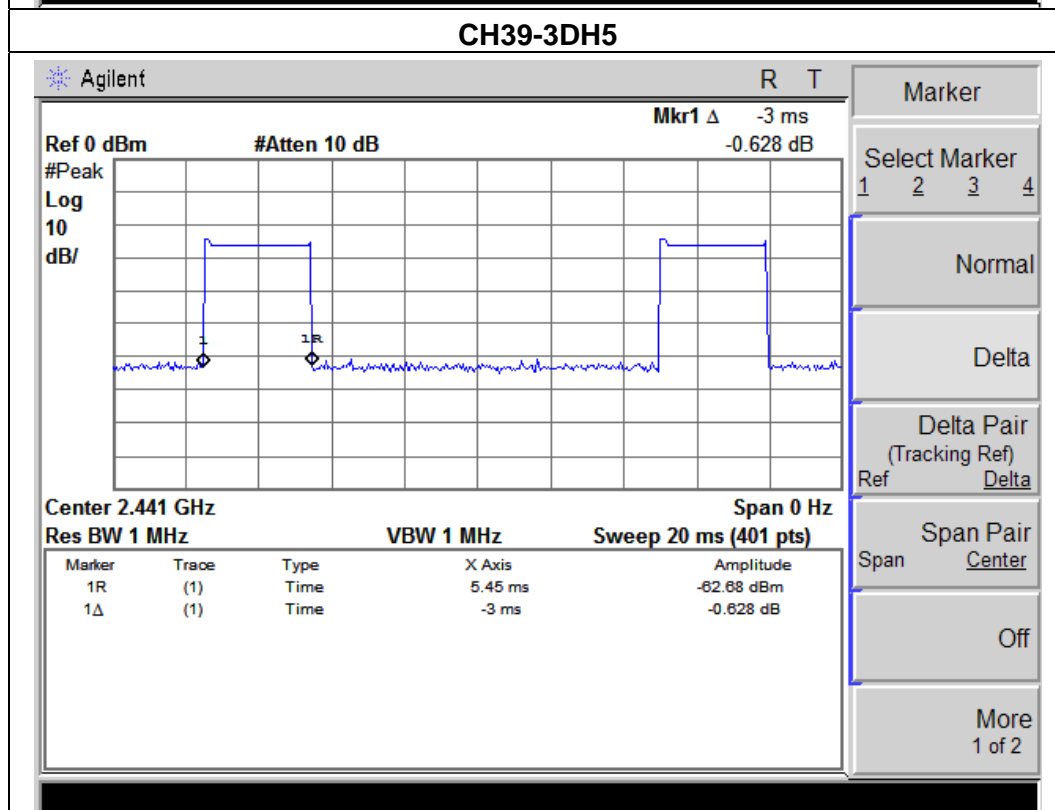
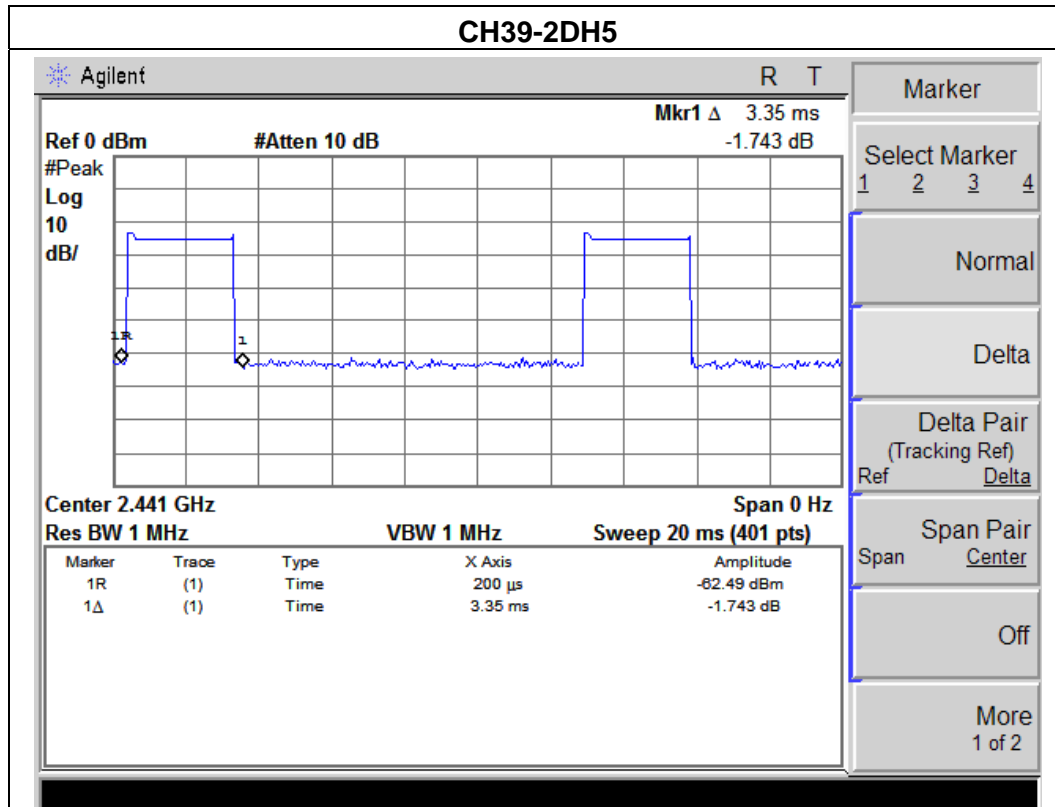

6. HOPPING CHANNEL SEPARATION MEASUREMENT

6.1 APPLIED PROCEDURES / LIMIT

Frequency hopping systems operating in the 2400-2483.5 MHz band may have hopping channel carrier frequencies that are separated by 25 kHz or two-thirds of the 20 dB bandwidth of the hopping channel, whichever is greater.

Spectrum Parameter	Setting
Attenuation	Auto
Span Frequency	> Measurement Bandwidth or Channel Separation
RB	100 kHz (Channel Separation)
VB	300 kHz (Channel Separation)
Detector	Peak
Trace	Max Hold
Sweep Time	Auto

6.1.1 TEST PROCEDURE

- a. The transmitter output (antenna port) was connected to the spectrum analyser in peak hold mode.
- b. The resolution bandwidth of 100 kHz and the video bandwidth of 300 kHz were utilised for channel separation measurement.

6.1.2 DEVIATION FROM STANDARD

No deviation.

6.1.3 TEST SETUP

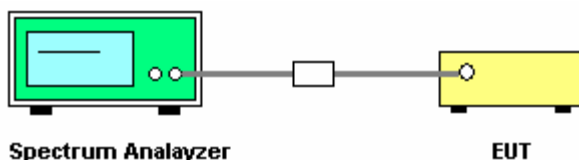

6.1.4 EUT OPERATION CONDITIONS

The EUT was programmed to be in continuously transmitting mode.

6.1.5 TEST RESULTS

EUT :	Bluetooth Wireless Mouse	Model Name :	iMouse M300W
Temperature :	25 °C	Relative Humidity :	60%
Pressure :	1012 hPa	Test Voltage :	DC 3V
Test Mode :	CH00 / CH39 /CH78 (1Mbps Mode)		

Frequency	Ch. Separation (MHz)	Result
2402 MHz	1.00	Complies
2441 MHz	1.01	Complies
2480 MHz	1.00	Complies

Ch. Separation Limits: >20dB bandwidth or >2/3 of 20dB bandwidth

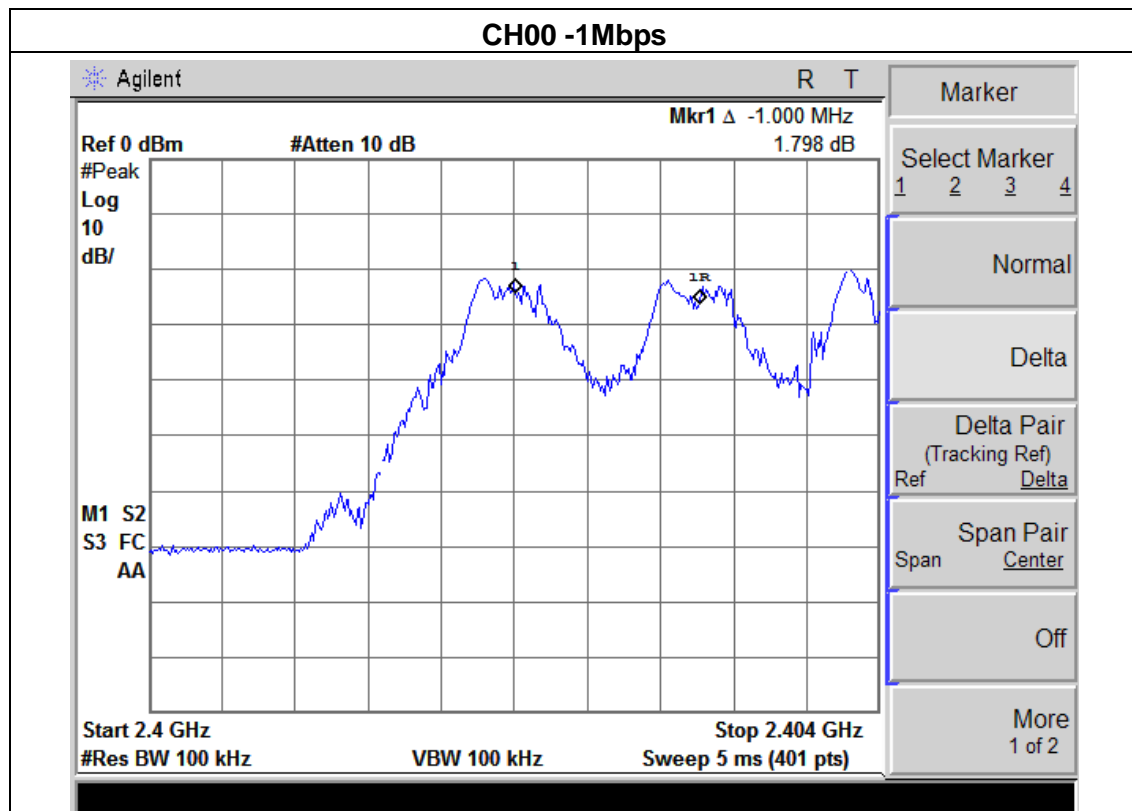

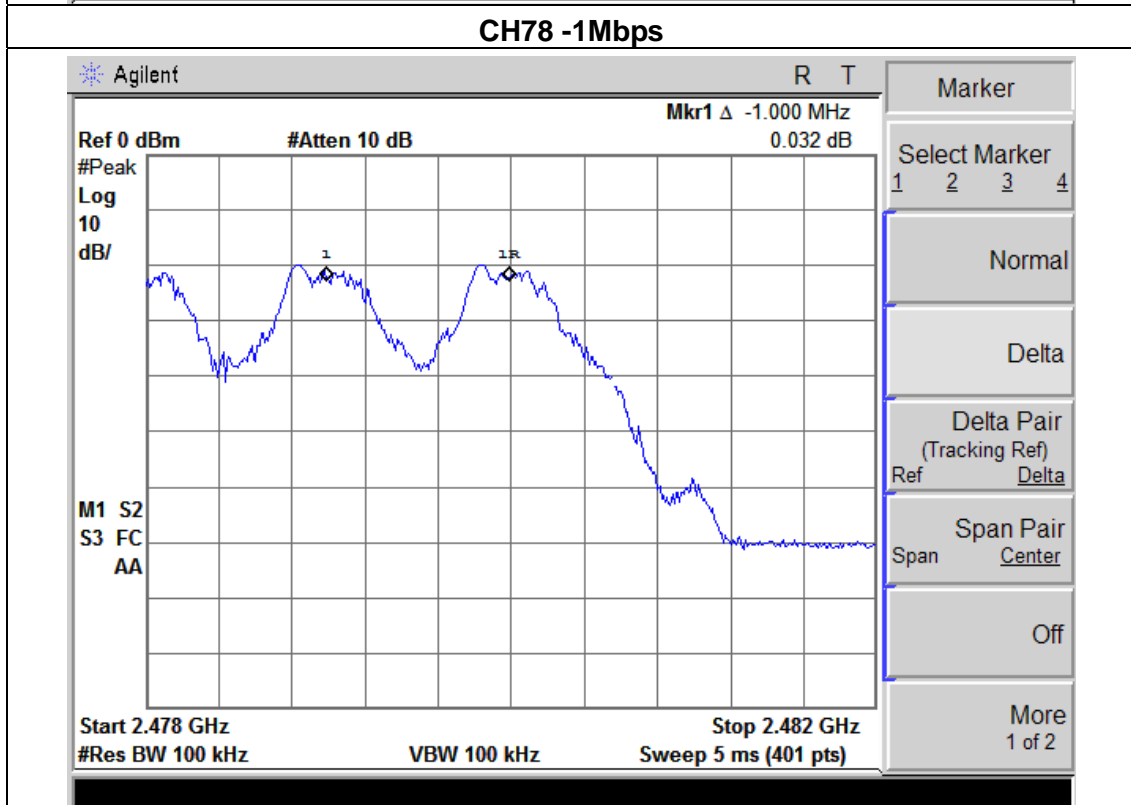
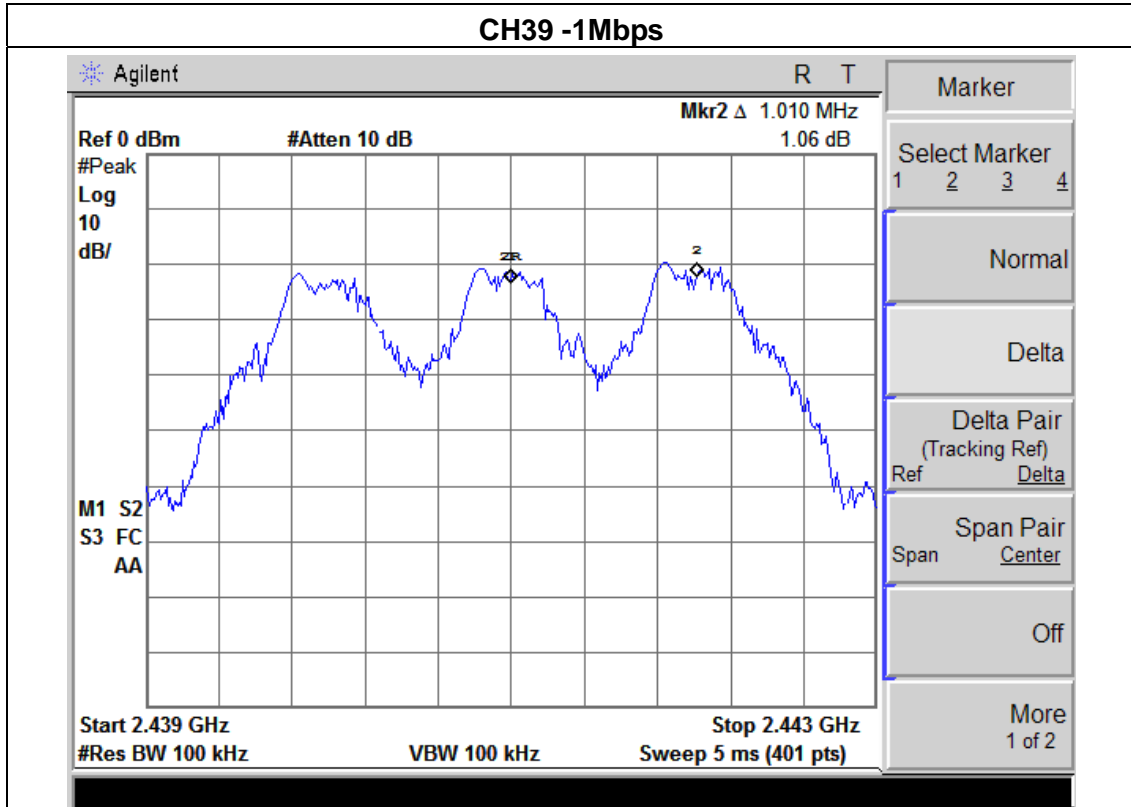

EUT :	Bluetooth Wireless Mouse	Model Name :	iMouse M300W
Temperature :	25 °C	Relative Humidity :	60%
Pressure :	1012 hPa	Test Voltage :	DC 3V
Test Mode :	CH00 / CH39 /CH78 (2Mbps Mode)		

Frequency	Ch. Separation (MHz)	Result
2402 MHz	1.01	Complies
2441 MHz	1.02	Complies
2480 MHz	1.00	Complies

Ch. Separation Limits: >20dB bandwidth or >2/3 of 20dB bandwidth

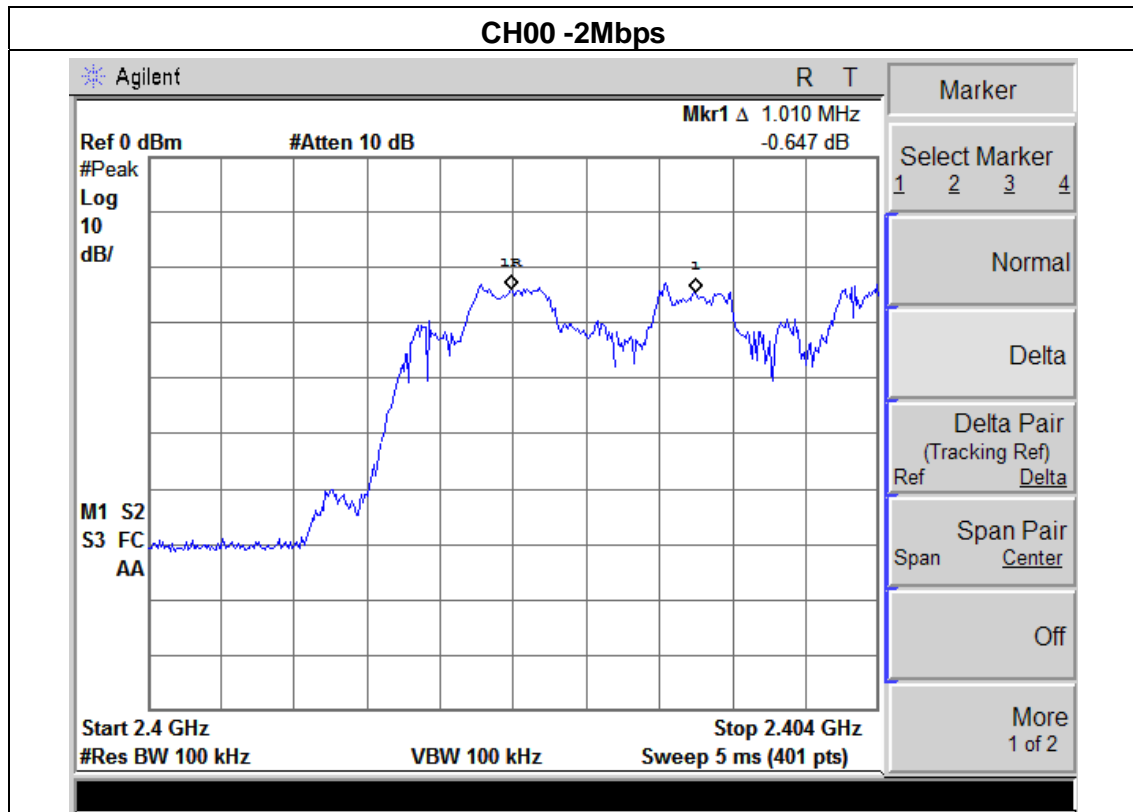

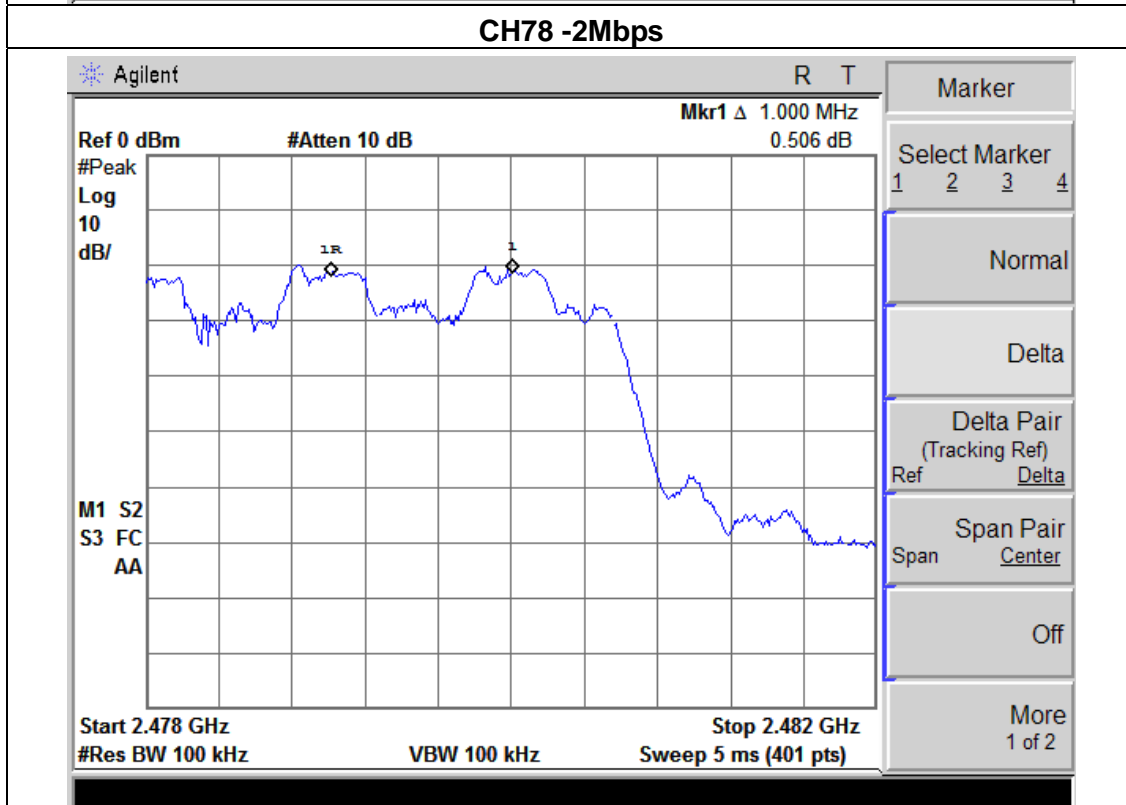
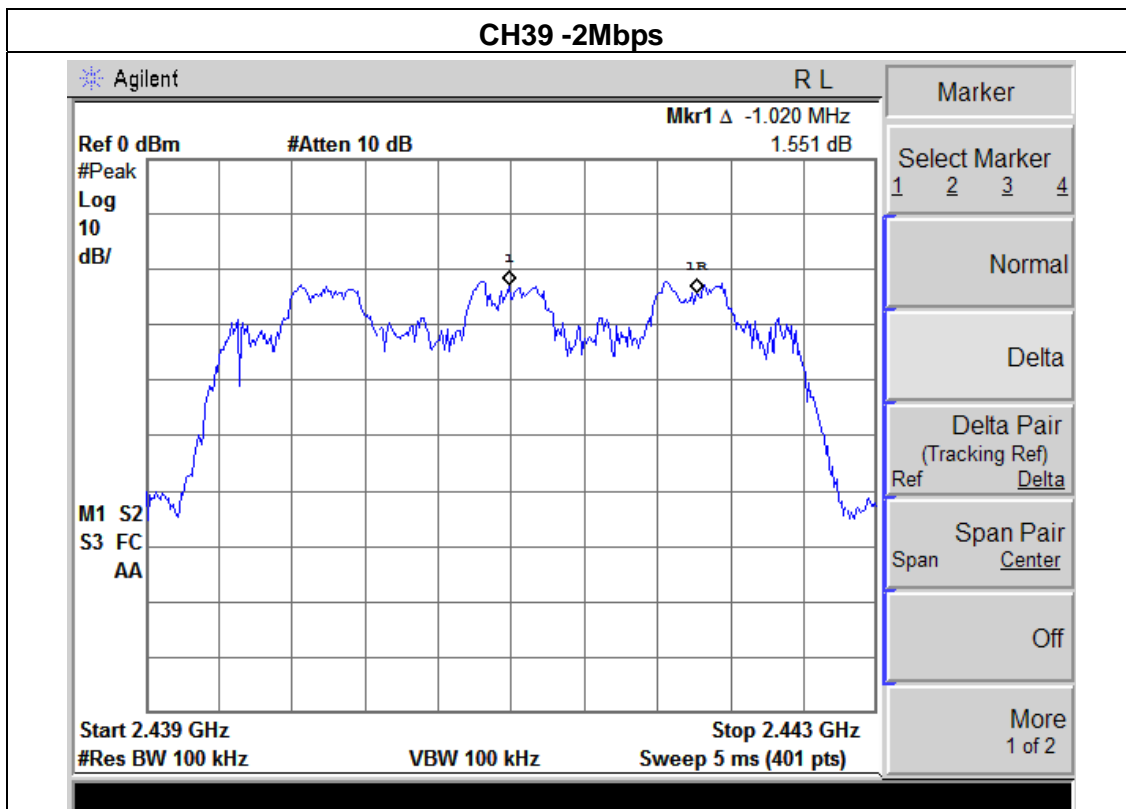

EUT :	Bluetooth Wireless Mouse	Model Name :	iMouse M300W
Temperature :	25 °C	Relative Humidity :	60%
Pressure :	1012 hPa	Test Voltage :	DC 3V
Test Mode :	CH00 / CH39 /CH78 (3Mbps Mode)		

Frequency	Ch. Separation (MHz)	Result
2402 MHz	1.03	Complies
2441 MHz	1.02	Complies
2480 MHz	1.01	Complies

Ch. Separation Limits: >20dB bandwidth or >2/3 of 20dB bandwidth

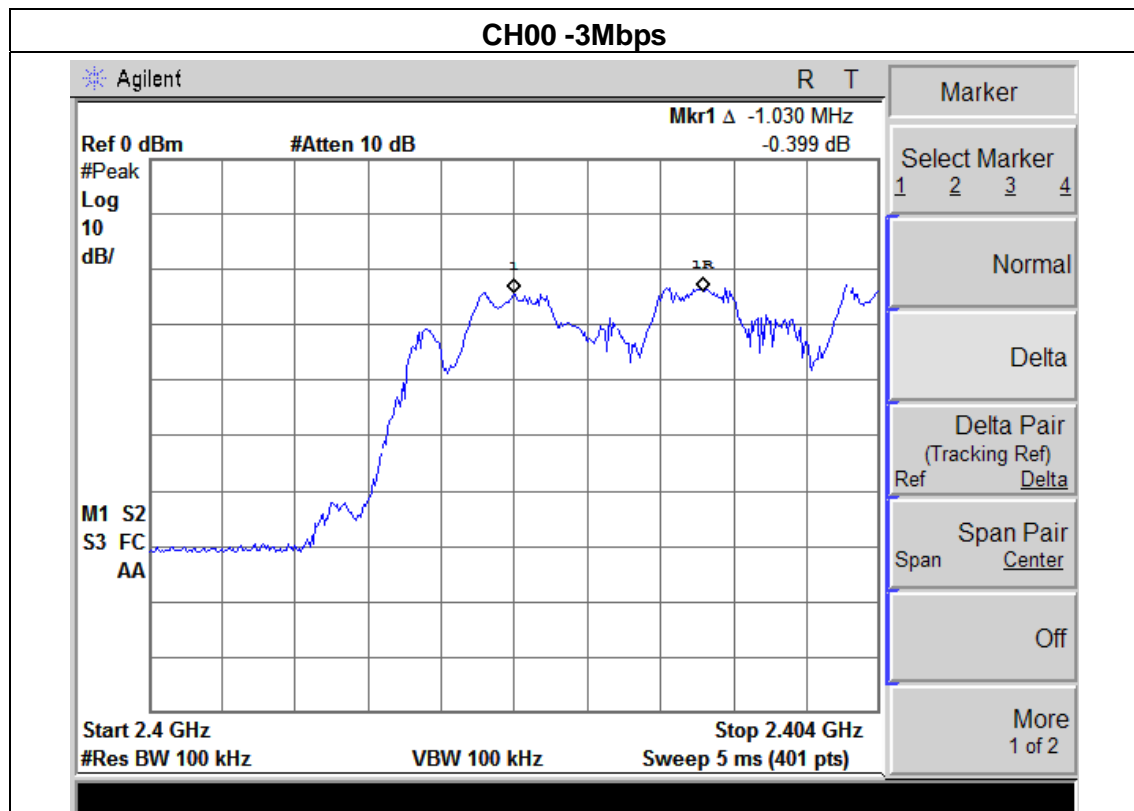

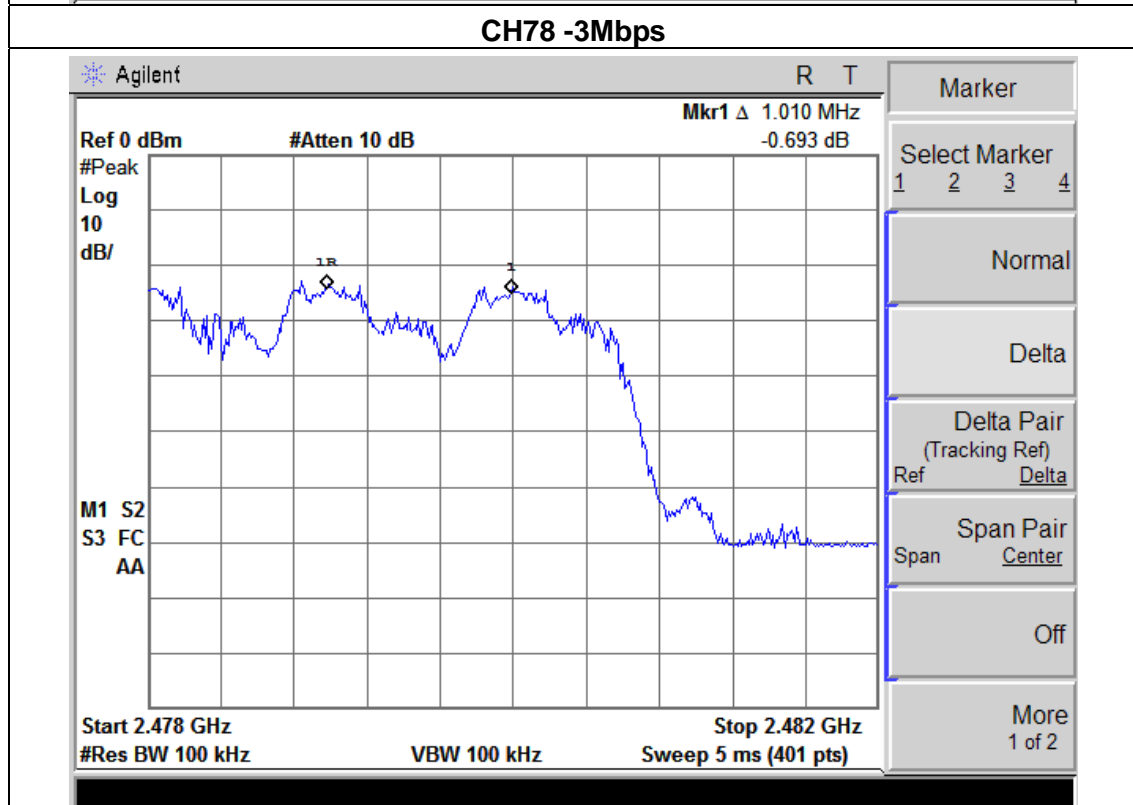
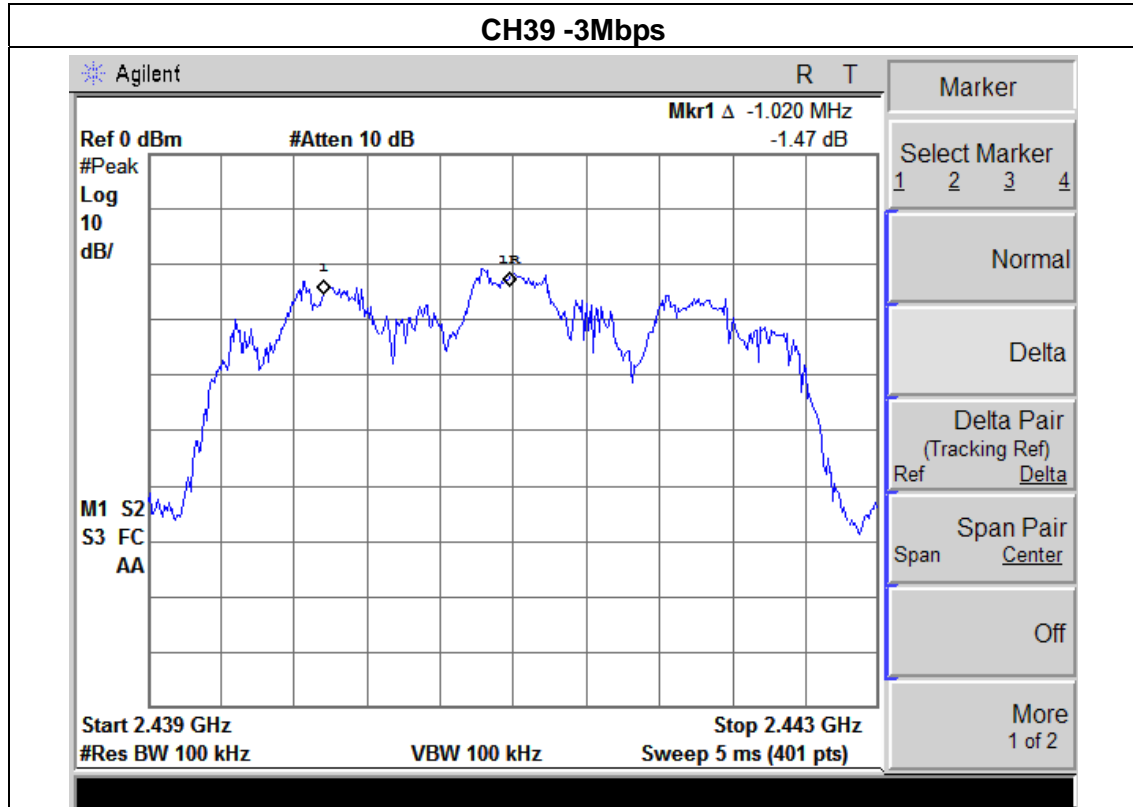

7. BANDWIDTH TEST

7.1 APPLIED PROCEDURES / LIMIT

FCC Part15 (15.247) , Subpart C				
Section	Test Item	Limit	Frequency Range (MHz)	Result
15.247 (a)(1)	Bandwidth	(20dB bandwidth)	2400-2483.5	PASS

Spectrum Parameter	Setting
Attenuation	Auto
Span Frequency	> Measurement Bandwidth or Channel Separation
RB	30 kHz
VB	100 kHz
Detector	Peak
Trace	Max Hold
Sweep Time	Auto

7.1.1 TEST PROCEDURE

- a. The EUT was directly connected to the spectrum analyzer and antenna output port as show in the block diagram below,
- b. Spectrum Setting : RBW= 30KHz, VBW=100KHz, Sweep time = Auto.

7.1.2 DEVIATION FROM STANDARD

No deviation.

7.1.3 TEST SETUP

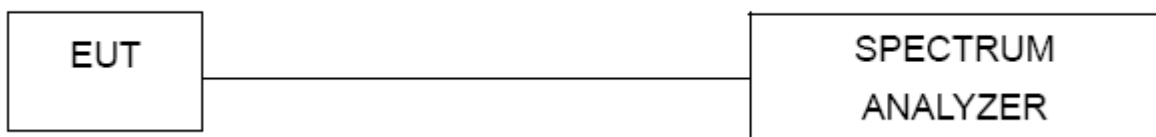

7.1.4 EUT OPERATION CONDITIONS

The EUT tested system was configured as the statements of 2.4 Unless otherwise a special operating condition is specified in the follows during the testing.

7.1.5 TEST RESULTS

EUT :	Bluetooth Wireless Mouse	Model Name :	iMouse M300W
Temperature :	25 °C	Relative Humidity :	60%
Pressure :	1012 hPa	Test Voltage :	DC 3V
Test Mode :	CH00 / CH39 /C78(1Mbps)		

Frequency	20dB Bandwidth (kHz)	Result
2402 MHz	812.129	PASS
2441 MHz	821.042	PASS
2480 MHz	828.745	PASS

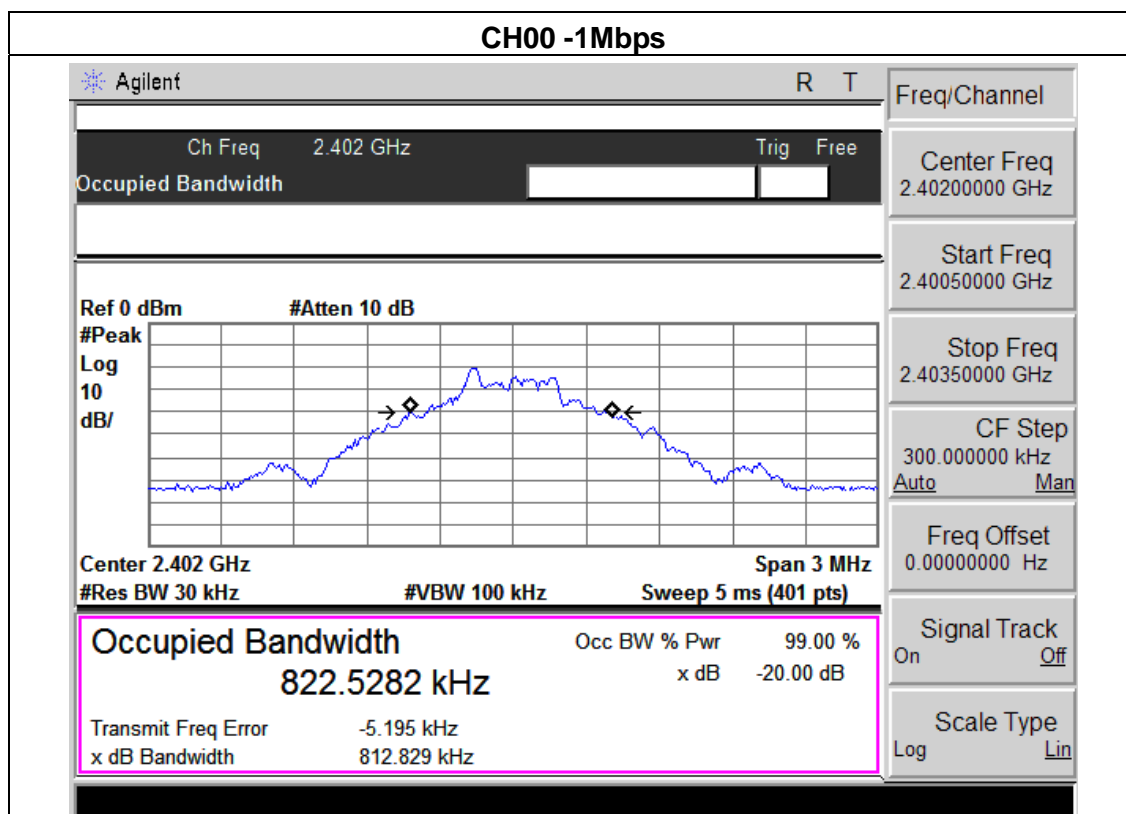

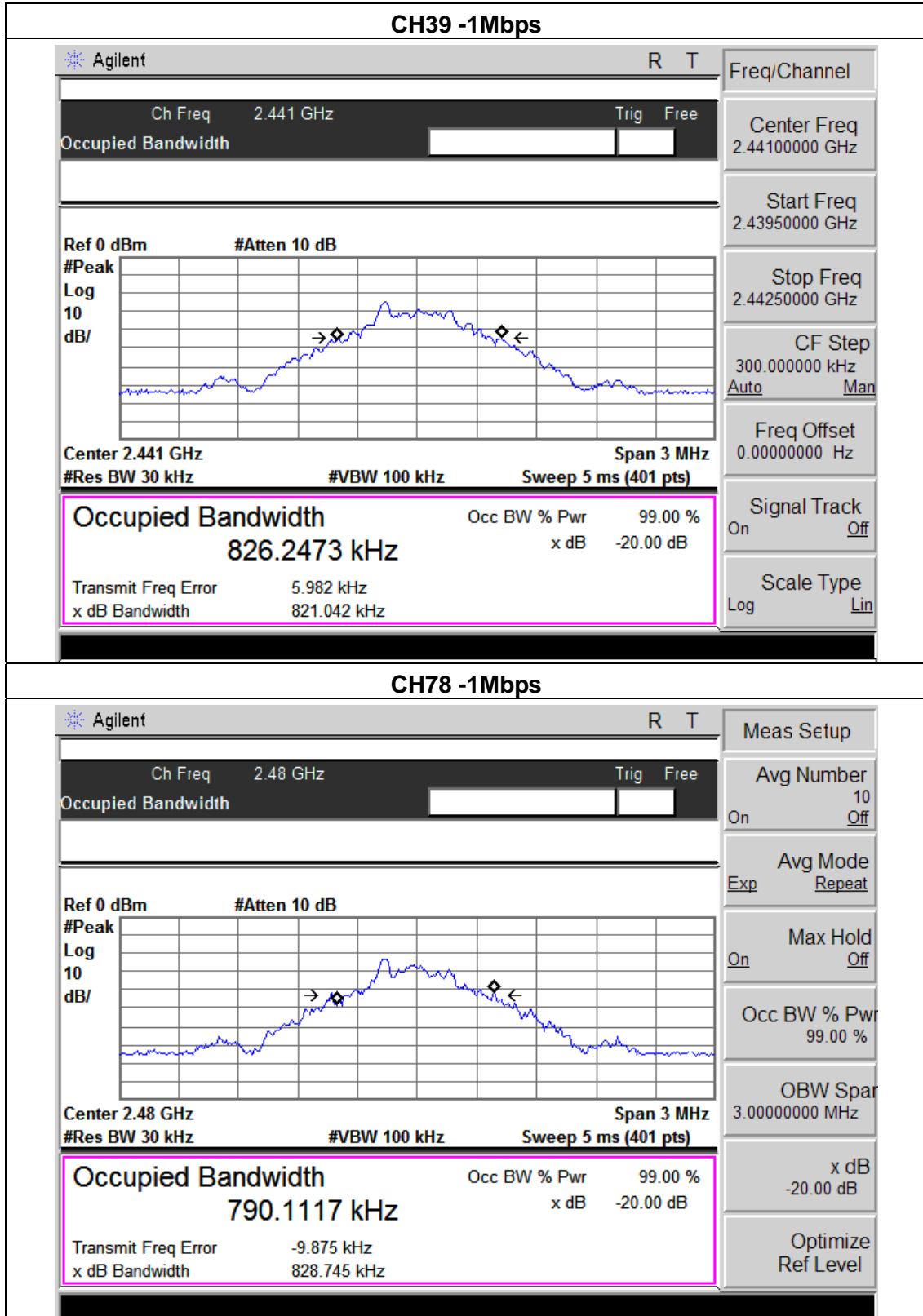

EUT :	Bluetooth Wireless Mouse	Model Name :	iMouse M300W
Temperature :	25 °C	Relative Humidity :	60%
Pressure :	1012 hPa	Test Voltage :	DC 3V
Test Mode :	CH00 / CH39 /C78(2Mbps)		

Frequency	20dB Bandwidth (MHz)	Result
2402 MHz	1.126	PASS
2441 MHz	1.108	PASS
2480 MHz	1.067	PASS

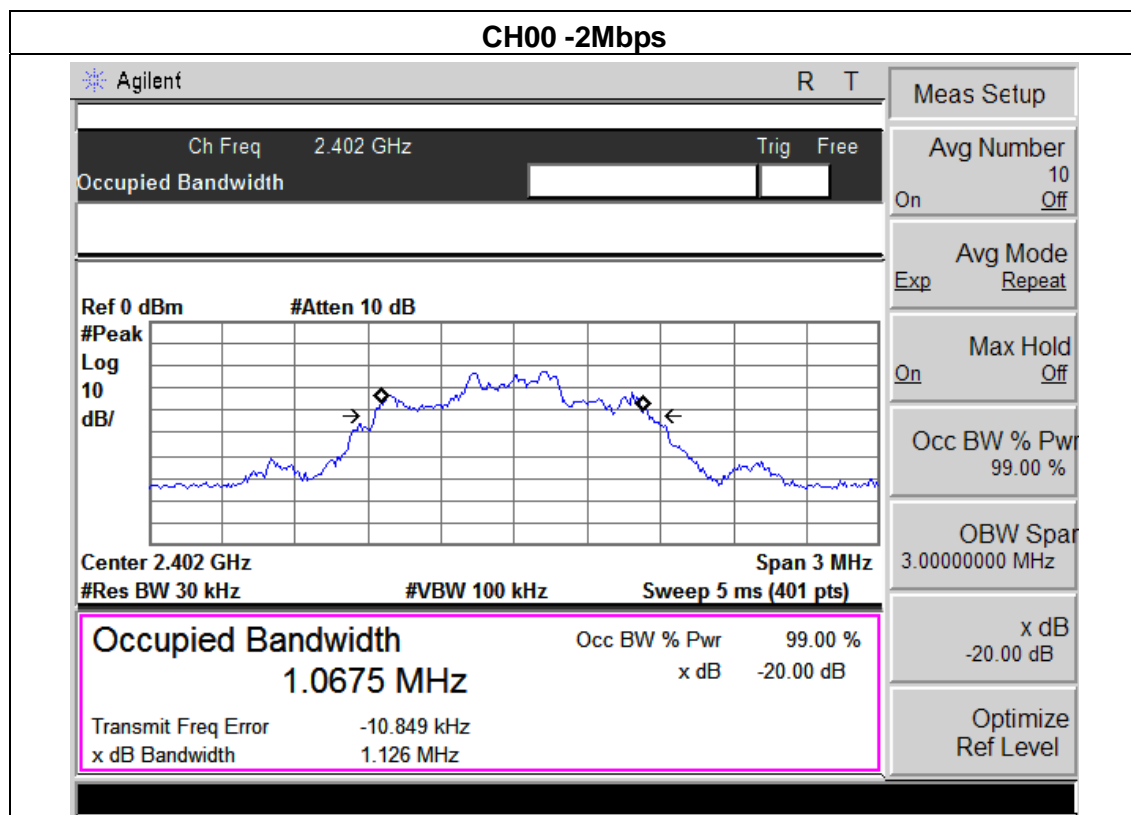

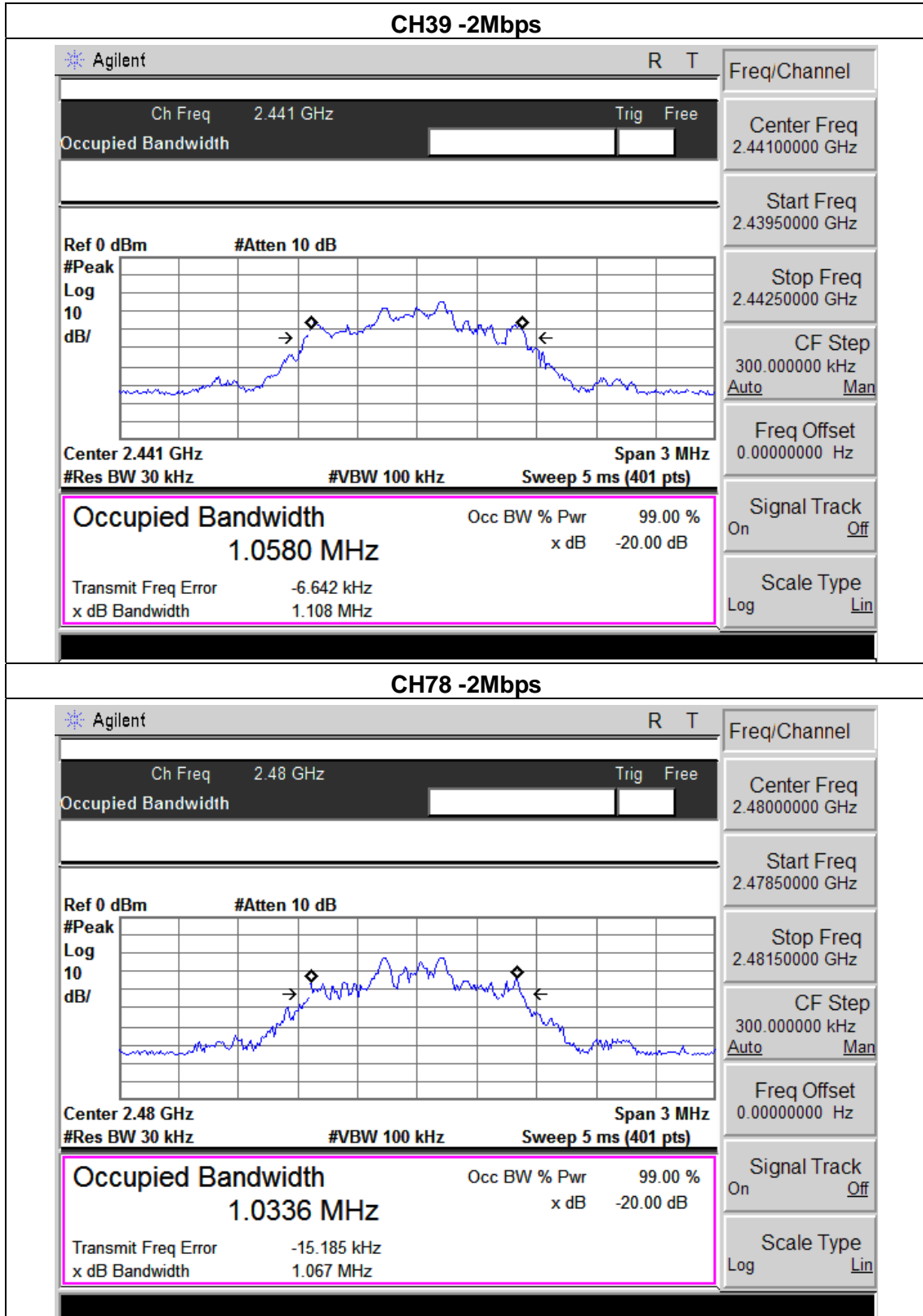

EUT :	Bluetooth Wireless Mouse	Model Name :	iMouse M300W
Temperature :	25 °C	Relative Humidity :	60%
Pressure :	1012 hPa	Test Voltage :	DC 3V
Test Mode :	CH00 / CH39 /C78(3Mbps)		

Frequency	20dB Bandwidth (MHz)	Result
2402 MHz	1.137	PASS
2441 MHz	1.115	PASS
2480 MHz	1.133	PASS

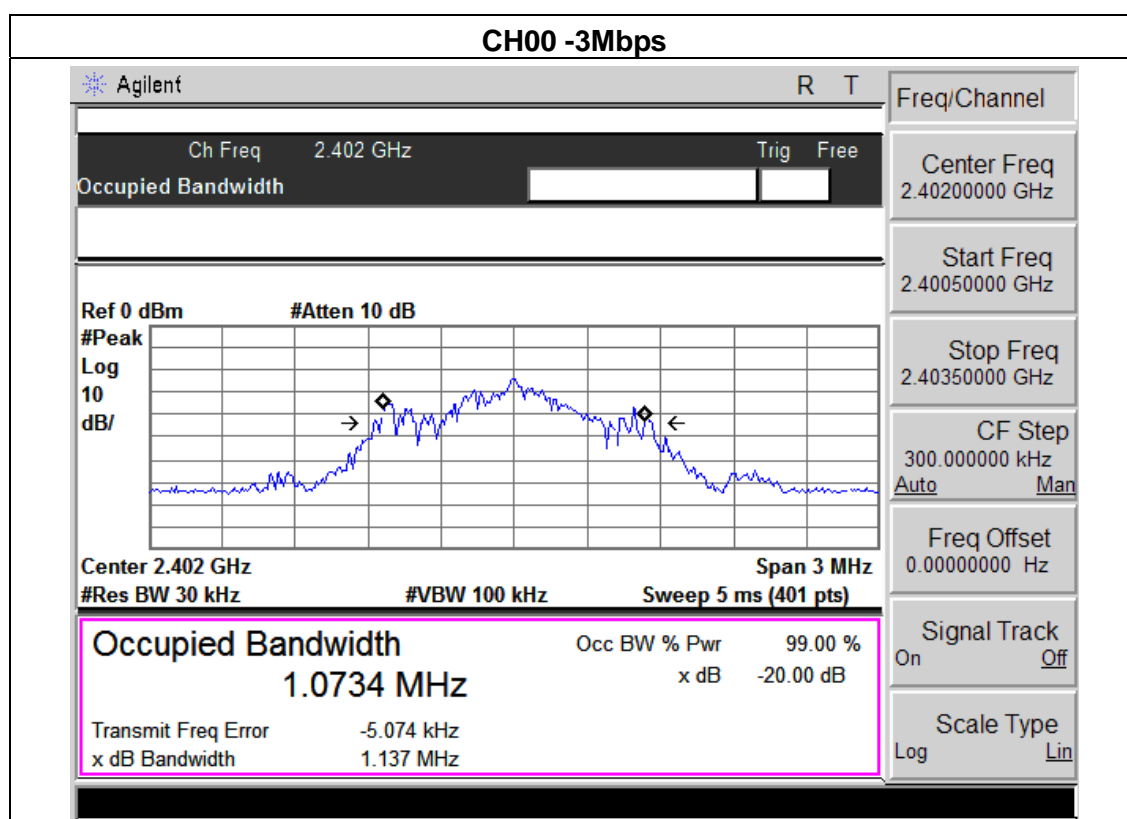

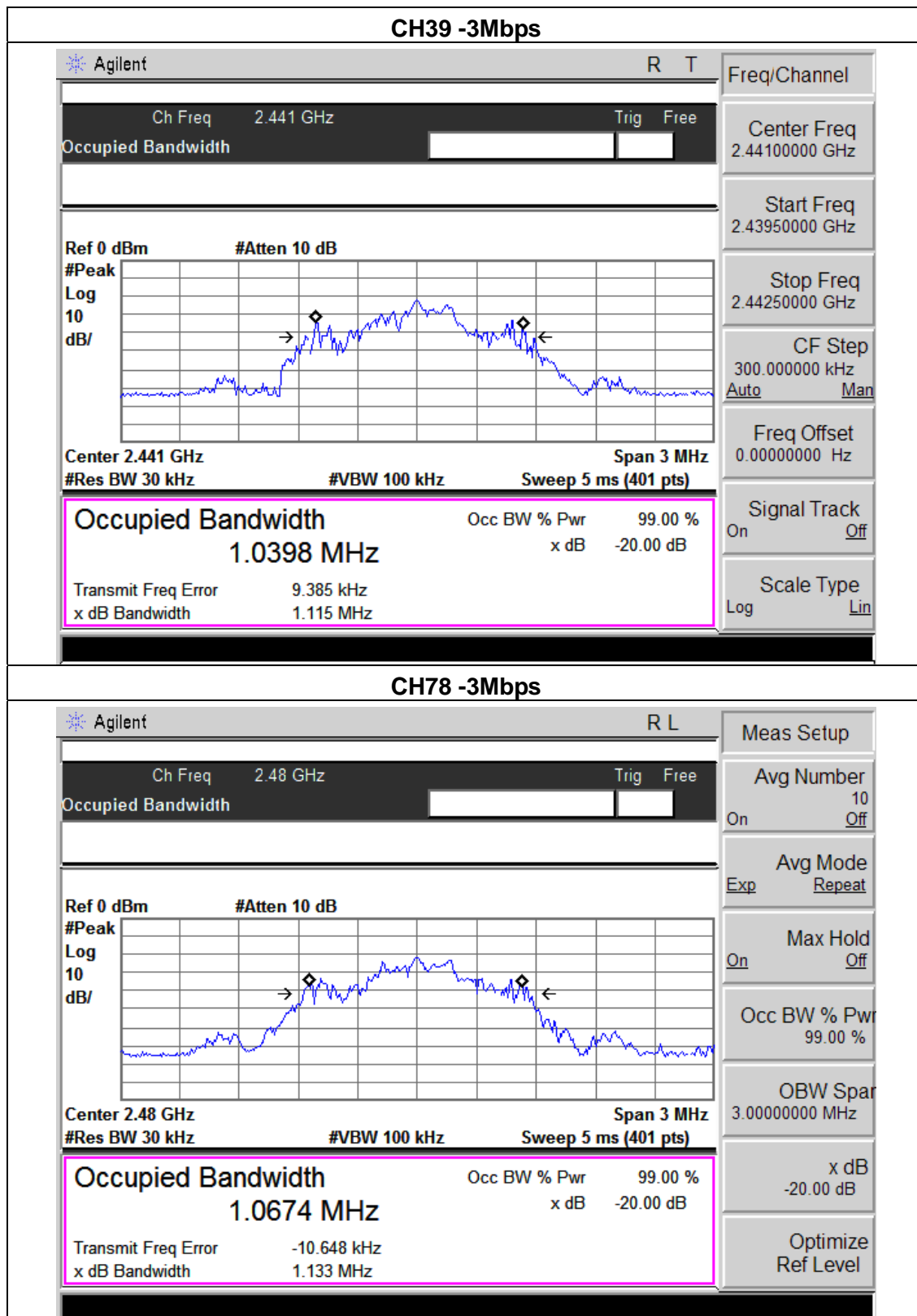

8. PEAK OUTPUT POWER TEST

8.1 APPLIED PROCEDURES / LIMIT

FCC Part15 (15.247) , Subpart C				
Section	Test Item	Limit	Frequency Range (MHz)	Result
15.247 (b)(i)	Peak Output Power	0.125 w or 20.96dBm	2400-2483.5	PASS

8.1.1 TEST PROCEDURE

- a. The EUT was directly connected to the spectrum analyzer and antenna output port as show in the block diagram below,
- b. Spectrum Setting : RBW > the 20 dB bandwidth of the emission being measured
 - Span = approximately 5 times the 20 dB bandwidth, centered on a hopping channel
 - VBW ≥ RBW
 - Sweep = auto
 - Detector function = peak
 - Trace = max hold

8.1.2 DEVIATION FROM STANDARD

No deviation.

8.1.3 TEST SETUP

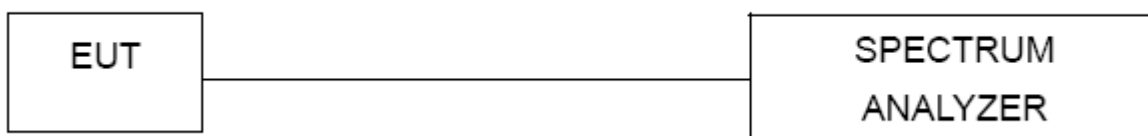

8.1.4 EUT OPERATION CONDITIONS

The EUT tested system was configured as the statements of 2.4 Unless otherwise a special operating condition is specified in the follows during the testing.

8.1.5 TEST RESULTS

EUT :	Bluetooth Wireless Mouse	Model Name :	iMouse M300W
Temperature :	25 °C	Relative Humidity :	60%
Pressure :	1012 hPa	Test Voltage :	DC 3V
Test Mode :	CH00/ CH39 /CH78 (1M/2M/3Mbps Mode)		

1Mbps			
Test Channel	Frequency (MHz)	Peak Output Power (dBm)	LIMIT (dBm)
CH00	2402	0.931	20.96
CH39	2441	-1.134	20.96
CH78	2480	0.285	20.96
2Mbps			
CH00	2402	0.824	20.96
CH39	2441	-0.469	20.96
CH78	2480	-0.601	20.96
3Mbps			
CH00	2402	-1.078	20.96
CH39	2441	-1.257	20.96
CH78	2480	-0.696	20.96

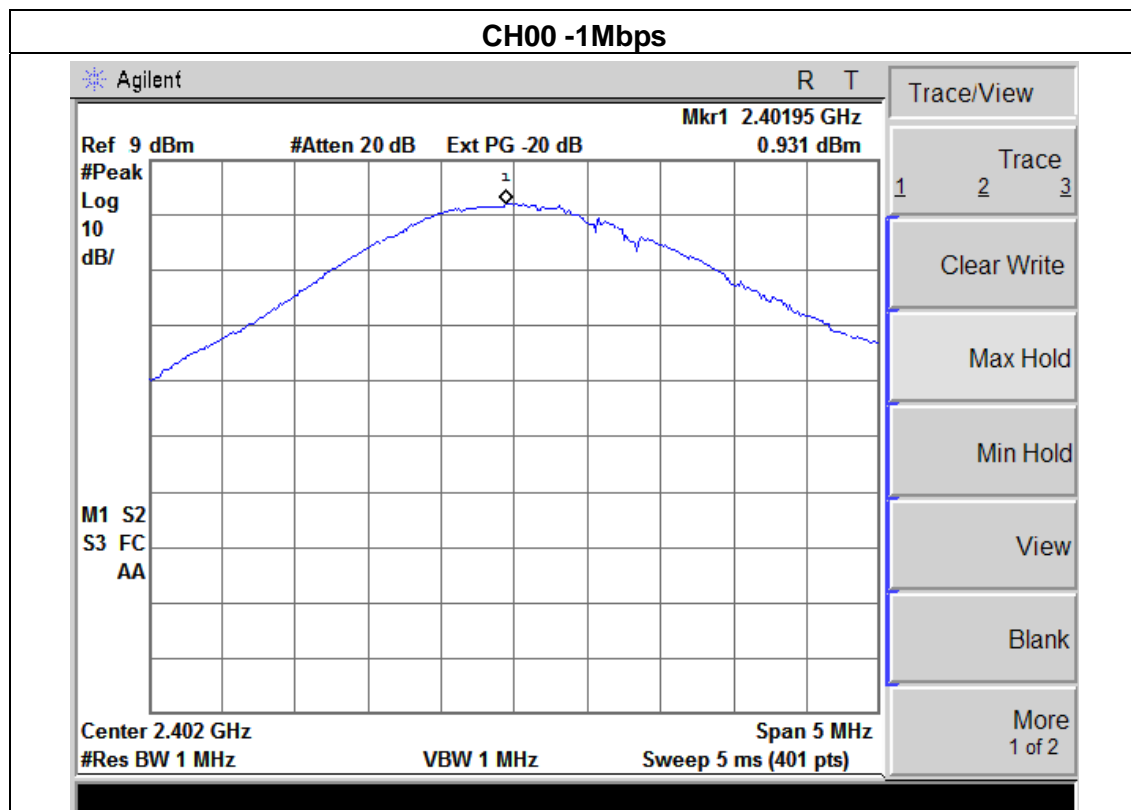

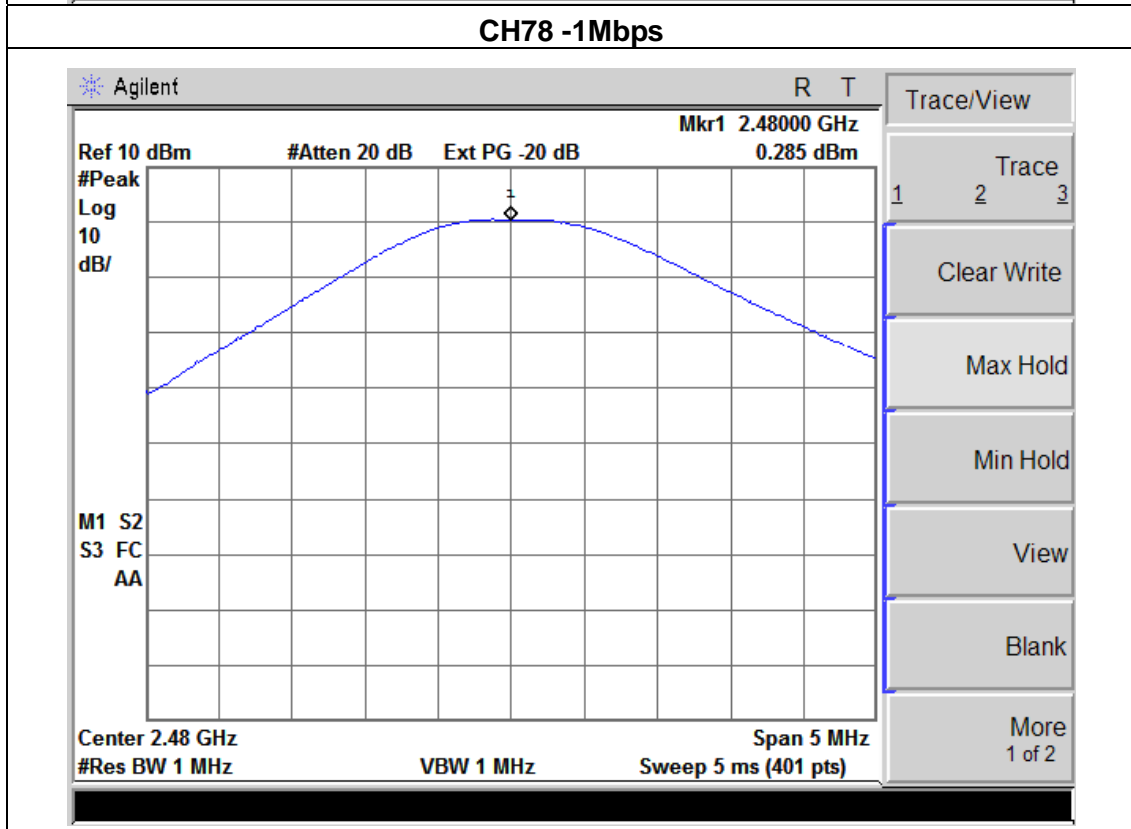
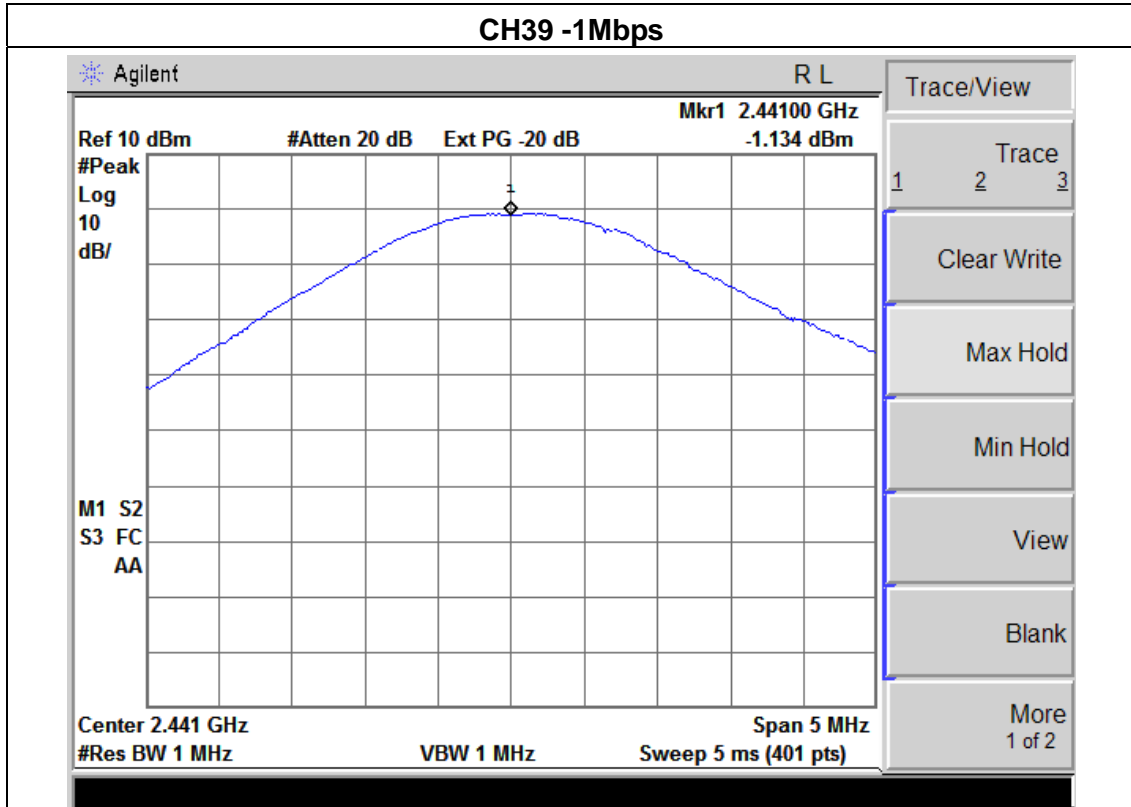

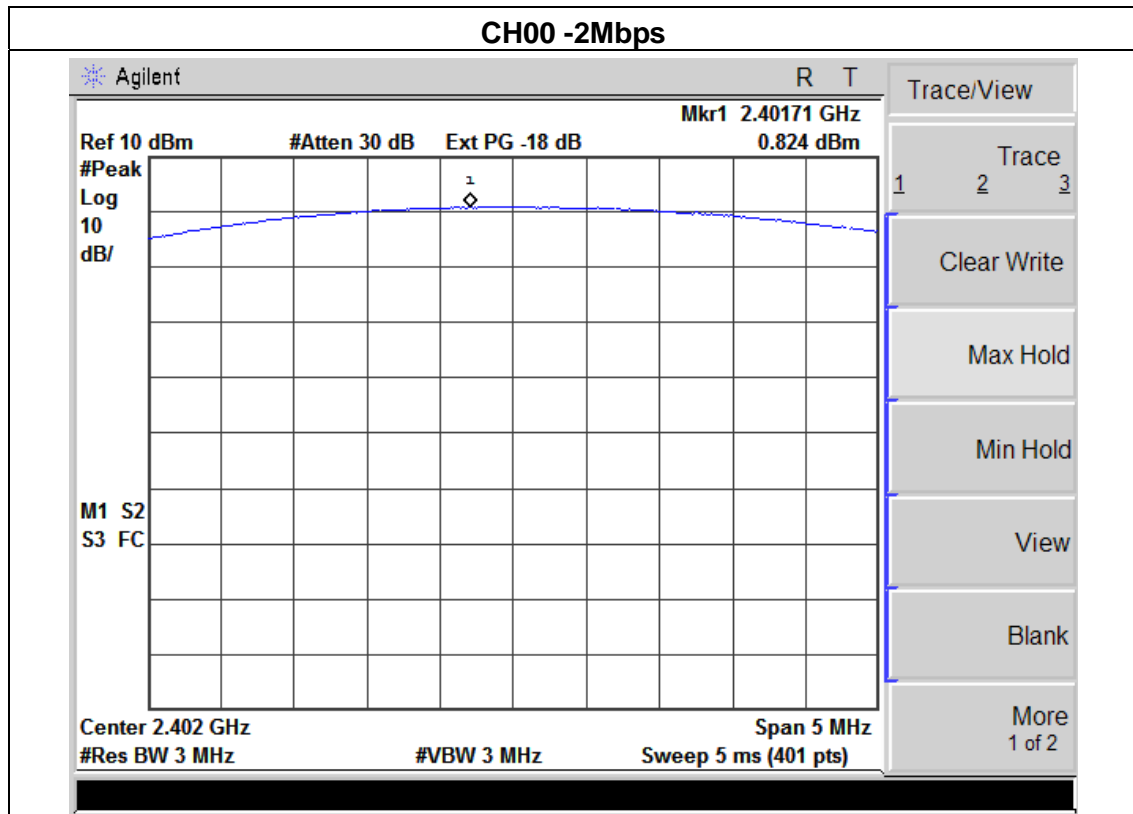

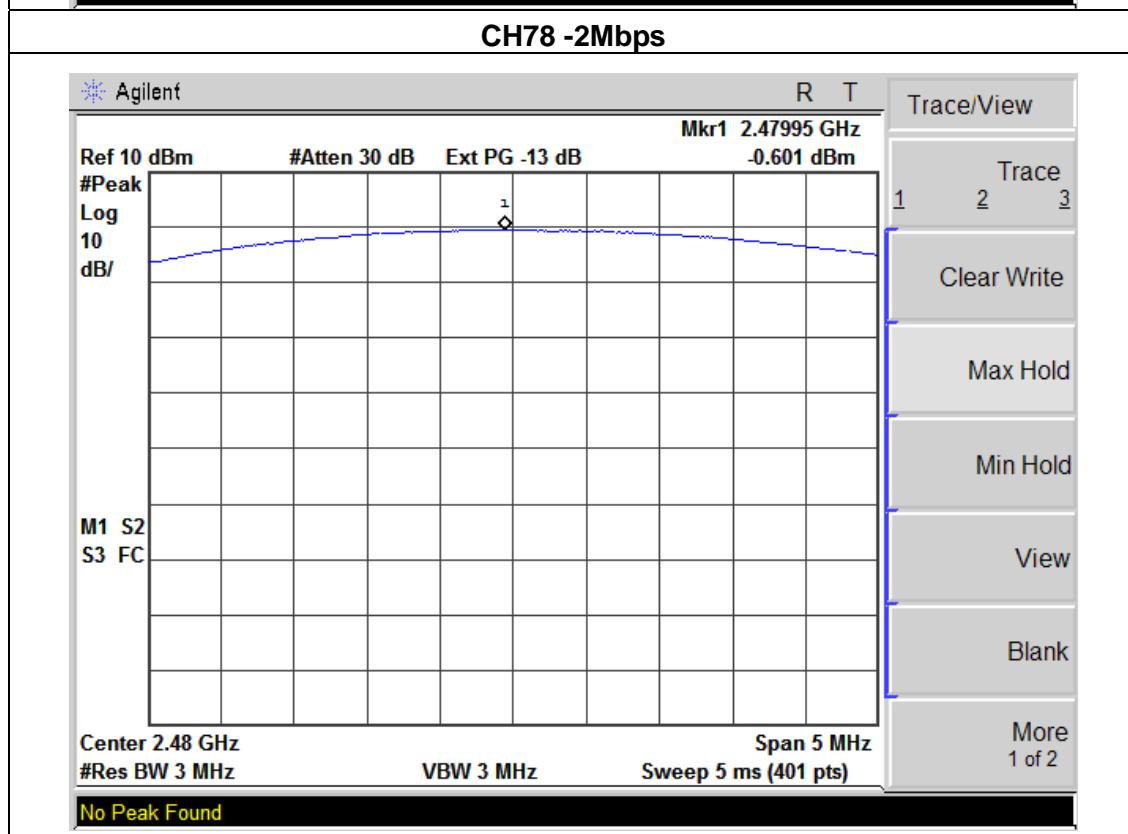
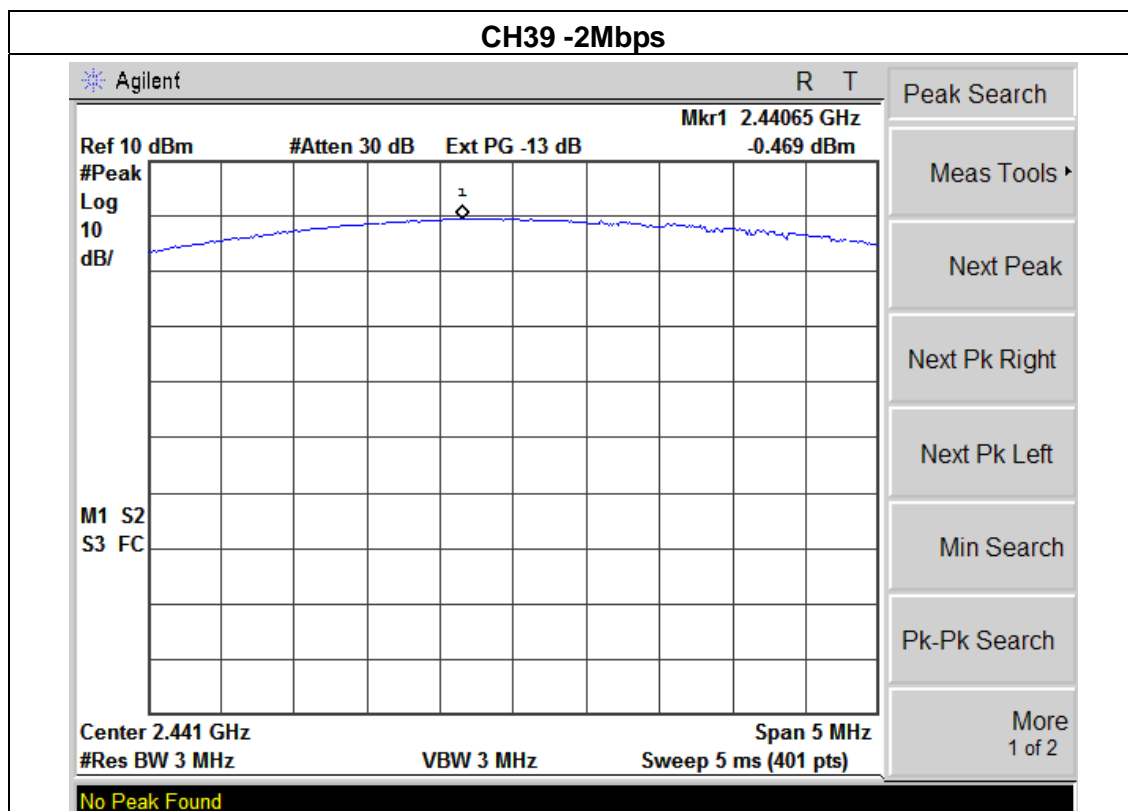

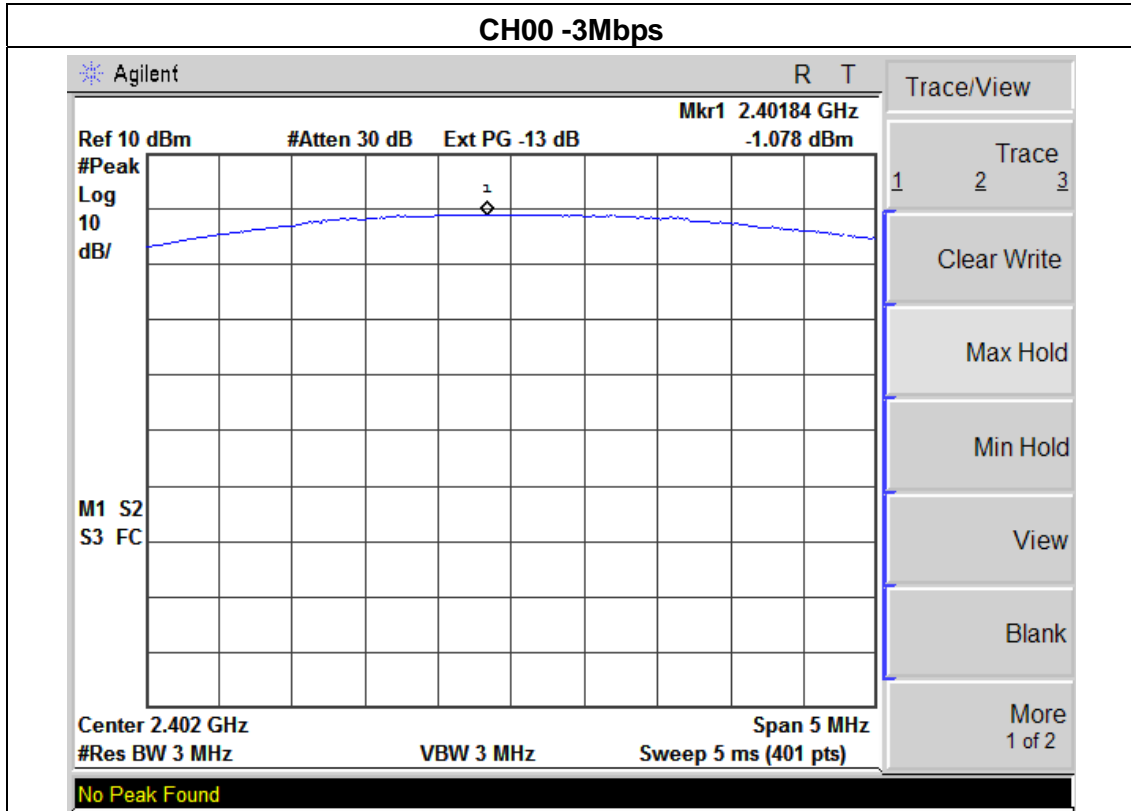

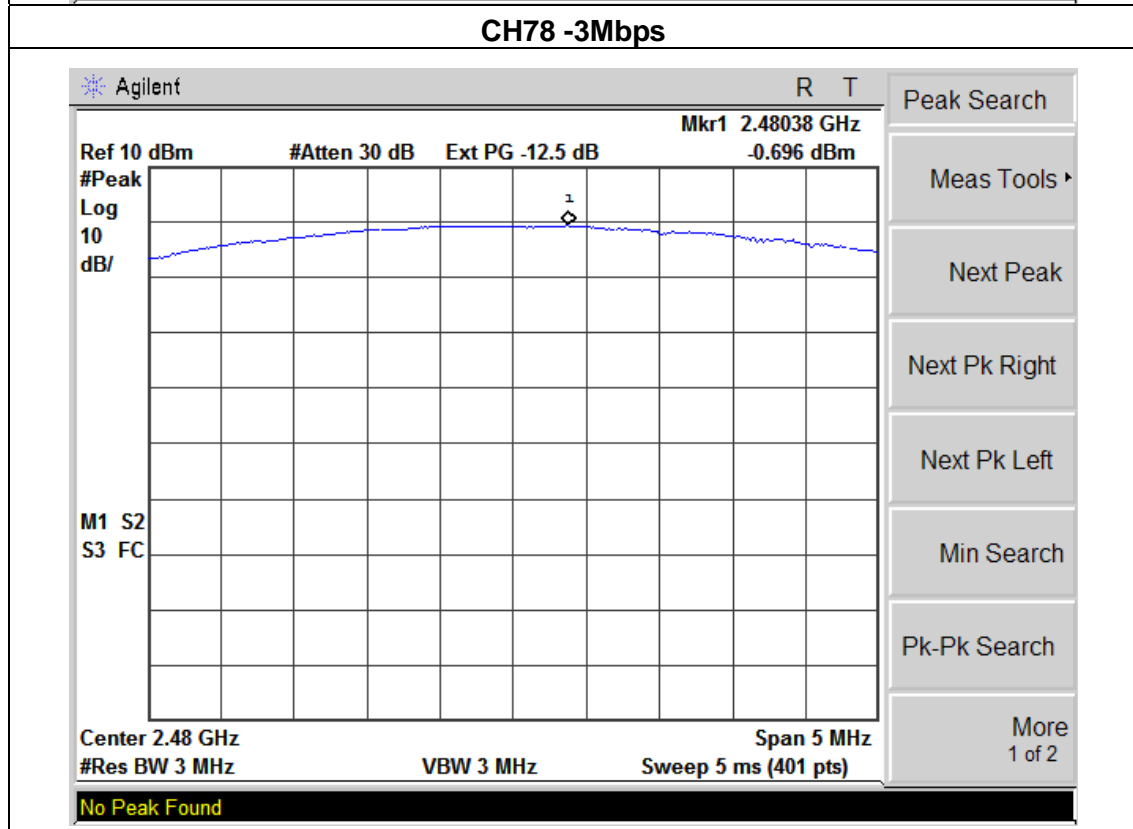
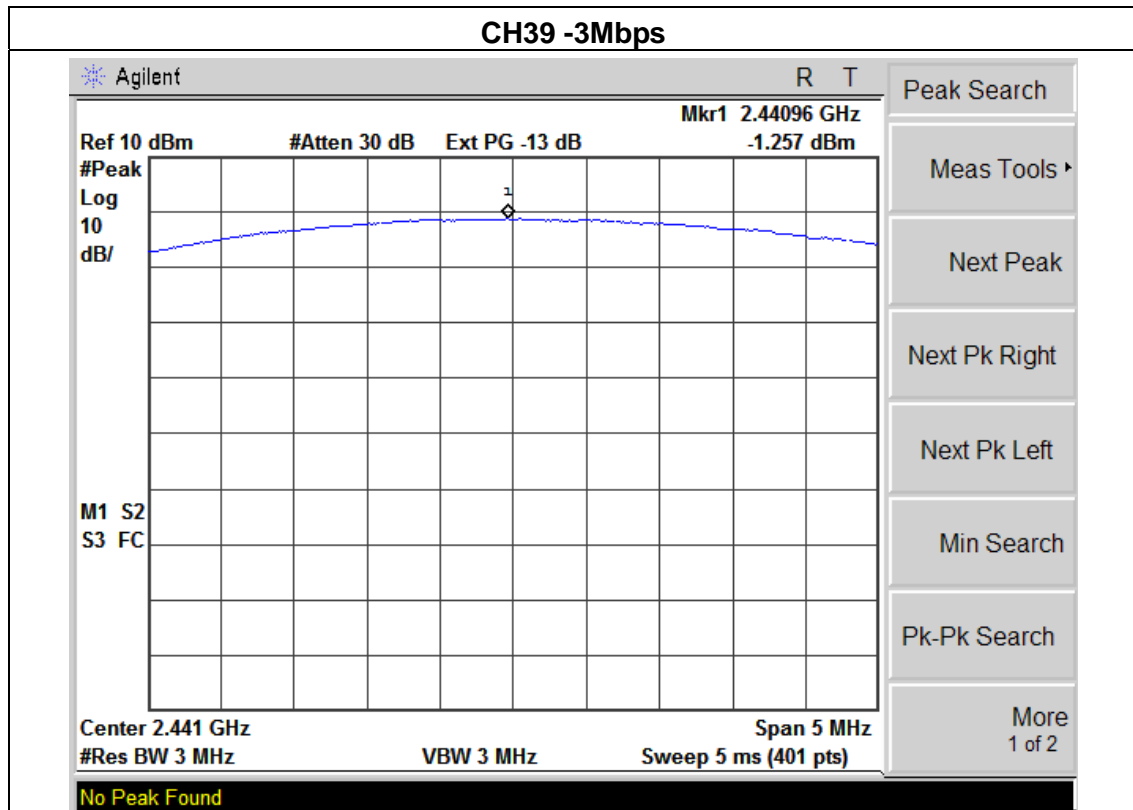

9. EUT TEST PHOTO

Radiated Measurement Photos

