



Willow Run Test Labs, LLC
8501 Beck Road, Building 2227
Belleville, Michigan 48111 USA
Tel: (734) 252-9785
Fax: (734) 926-9785
e-mail: info@wrtest.com

Testing of
Electromagnetic Emissions

per

USA: CFR Title 47, Part 15.247
Canada: IC RSS-210/GENe

are herein reported for

Inspectron, Inc.
i2000

Test Report No.: 20130713-01r1
Copyright © 2013

Applicant/Provider:
Inspectron, Inc.

39625 Lewis Drive, Suite 900, Novi Michigan 48377 USA
Phone: +1 (248) 978-9943, Fax: +1 (248) 978-9943
Contact Person: Andrew Donaldson; adonaldson@inspectrontools.com

Measured by: 
Dr. Joseph Brunett, EMC-002790-NE

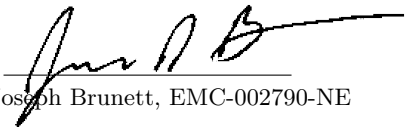
Report Approved by: 
Dr. Joseph Brunett, EMC-002790-NE

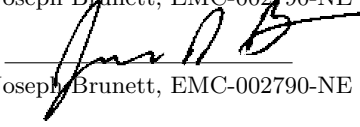
Report by: 
Dr. Joseph Brunett, EMC-002790-NE

Report Date of Issue: July 19, 2013

Results of testing the equipment under test (EUT) as completed on July 19, 2013 are as follows.

Emissions: The transmitter fundamental emission meets the regulatory limit(s) by no less than 17.8 dB. Transmit chain spurious harmonic emissions comply by no less than 0.2 dB. Radiated spurious emissions associated with the receive chain of this device meet the regulatory limit(s) by no less than 4.4 dB. Unintentional spurious emissions from digital circuitry comply with the radiated emission limit(s) by more than 4.0 dB. AC Power Line conducted emissions comply by more than 3.8 dB.

Contents

1	Test Specifications, General Procedures, and Location	4
1.1	Test Specification and General Procedures	4
1.2	Test Location and Equipment Used	5
2	Configuration and Identification of the Equipment Under Test	6
2.1	Description and Declarations	6
2.1.1	EUT Configuration	6
2.1.2	Modes of Operation	6
2.1.3	Variants	7
2.1.4	Test Samples	7
2.1.5	Functional Exerciser	7
2.1.6	Modifications Made	8
2.1.7	Production Intent	8
2.1.8	Declared Exemptions and Additional Product Notes	8
3	Emissions	9
3.1	General Test Procedures	9
3.1.1	Radiated Test Setup and Procedures	9
3.1.2	Conducted Emissions Test Setup and Procedures	11
3.1.3	Power Supply Variation	11
3.1.4	Thermal Variation	12
3.2	Intentional Emissions	13
3.2.1	Fundamental Emission Bandwidth	13
3.2.2	Effective Isotropic Radiated Power	16
3.2.3	Power Spectral Density	18
3.3	Unintentional Emissions	19
3.3.1	Transmit Chain Spurious Emissions	19
3.3.2	Radiated Receiver Spurious	20
3.3.3	Radiated Digital Spurious	21
3.3.4	Conducted Transmitter Spurious	22
3.3.5	Conducted Emissions Test Results - AC Power Port(s)	23

List of Tables

1	Willow Run Test Labs, LLC Equipment List.	5
2	EUT Declarations.	6
3	Intentional Emission Bandwidth.	13
4	Radiated Power Results.	16
5	Power Spectral Density Results.	18
6	Transmit Chain Spurious Emissions.	19
7	Receiver Chain Spurious Emissions \geq 30 MHz.	20
8	Radiated Digital Spurious Emissions.	21
9	AC Mains Power Conducted Emissions Results.	23

List of Figures

1	Photos of EUT.	6
2	EUT Test Configuration Diagram.	7
3	Radiated Emissions Diagram of the EUT.	9
4	Radiated Emissions Test Setup Photograph(s).	10
5	Conducted RF Test Setup Photograph(s).	11
6	Conducted Emissions Setup Diagram of the EUT.	12

7 Conducted Emissions Test Setup Photograph(s). 12

8 Intentional Emission Bandwidth. 14

8 Intentional Emission Bandwidth. 14

8 Intentional Emission Bandwidth. 15

9 Power Measurement Plots. 17

10 Power Spectral Density Plots. 18

11 Conducted Receiver Emissions Measured. 22

1 Test Specifications, General Procedures, and Location

1.1 Test Specification and General Procedures

The ultimate goal of Inspectron, Inc. is to demonstrate that the EUT complies with the Rules and/or Directives below. Detailed in this report are the results of testing the Inspectron, Inc. i2000 for compliance to:

Country/Region	Rules or Directive	Referenced Section(s)
United States	Code of Federal Regulations	CFR Title 47, Part 15.247
Canada	Industry Canada	IC RSS-210/GENe

In association with the rules and directives outlined above, the following specifications and procedures are followed herein.

ANSI C63.4-2003	"Methods of Measurement of Radio-Noise Emissions from Low-Voltage Electrical and Electronic Equipment in the Range of 9 kHz to 40 GHz"
FCC KDB 558074 (2013)	"Guidance for Performing Compliance Measurements on Digital Transmission Systems (DTS) Operating Under 15.247"
FCC KDB 913591 (2007)	"Measurement of radiated emissions at the edge of the band for a Part 15 RF Device"
ICES-003; Issue 5 (2012)	"Information Technology Equipment (ITE) Limits and methods of measurement"
Industry Canada	"The Measurement of Occupied Bandwidth"

1.2 Test Location and Equipment Used

Test Location The EUT was fully tested at **Willow Run Test Labs, LLC**, 8501 Beck Road, Building 2227, Belleville, Michigan 48111 USA. The Test Facility description and attenuation characteristics are on file with the FCC Laboratory, Columbia, Maryland (FCC Reg. No: 688478) and with Industry Canada, Ottawa, ON (File Ref. No: IC 8719A-1).

Test Equipment Pertinent test equipment used for measurements at this facility is listed in Table 1. The quality system employed at Willow Run Test Labs, LLC has been established to ensure all equipment has a clearly identifiable classification, calibration expiry date, and that all calibrations are traceable to the SI through NIST, other recognized national laboratories, accepted fundamental or natural physical constants, ratio type of calibration, or by comparison to consensus standards.

Table 1: Willow Run Test Labs, LLC Equipment List.

Description	Manufacturer/Model	SN	Quality Number	Last Cal By / Date Due
Antennas				
Shielded Loop (9 kHz - 50 MHz)	EMCO/6502	2855	UMLOOP1	UMRL / July-2014
Dipole Set (20 MHz - 1000 MHz)	EMCO/3121C	9504-1121	DIPEMC001	Liberty Labs / Sept-2013
Bicone (20 MHz - 250 MHz)	JEF	1	BICJEF001	UMRL / July-2014
Bicone (200 MHz - 1000 MHz)	JEF	1	SBICJEF001	UMRL / July-2014
Log-Periodic Array (200 MHz - 1000 MHz)	JEF/Isbell	1	LOGJEF001	UMRL / July-2014
Ridge-Horn Antenna	Univ. of Michigan	5	UMHORN005	UMRL / July-2014
L-Band	JEF		HRNL001	JEF / July-2014*
LS-Band Horns	JEF/NRL	001, 002	HRN15001, HRN15002	JEF / July-2014*
S-Band Horns	Scientific-Atlanta	1854	HRNSB001	JEF / July-2014*
C-Band	JEF/NRL	1	HRNC001	JEF / July-2014*
XN-Band Horns	JEF/NRL	001, 002	HRNXN001, HRNXN002	JEF / July-2014*
X-Band Horns	JEF/NRL	001, 002	HRNXB001, HRNXB002	JEF / July-2014*
Ku-Band Horns	JEF/NRL	001, 002	HRNKU001, HRNKU002	JEF / July-2014*
Ka-Band Horns	JEF/NRL	001, 002	HRNKA001, HRNKA002	JEF / July-2014*
Quad-Ridge Horns	Condor AS-48461	C35200	QRH218001	WRTL / July-2014
Receiver's / Spectrum Analyzers				
Spectrum Analyzer	HP/8593E	3649A02722	HP8593E001	DTI / Nov-2013
Signal Generators				
Tracking Generator	HP/8593E	3649A02722	HP8593E001	DTI / Nov-2013
Line Impedance Stabilization Networks				
LISN	EMCO	9304-2081	LISNEM001	JEF / Jan-2014

* Verification Only - Standard Gain Horn Antennas

2 Configuration and Identification of the Equipment Under Test

2.1 Description and Declarations

The EUT is a 2.4 GHz Digital Spread Spectrum commercial video transmitter with camera snake. The equipment under test (EUT) is approximately 11 x 32 x 7 cm in dimension, and is depicted in Figure 1. It is powered by a 3.7 VDC lithium-ion rechargeable battery. This device is envisioned to be a commercial digitized video transmitter (used in conjunction with the BK8000-RX commercial video receiver) for use in inspection of tubes, hollow bodies, and cavities by a professional tradesman. Table 2 outlines provider declared EUT specifications.

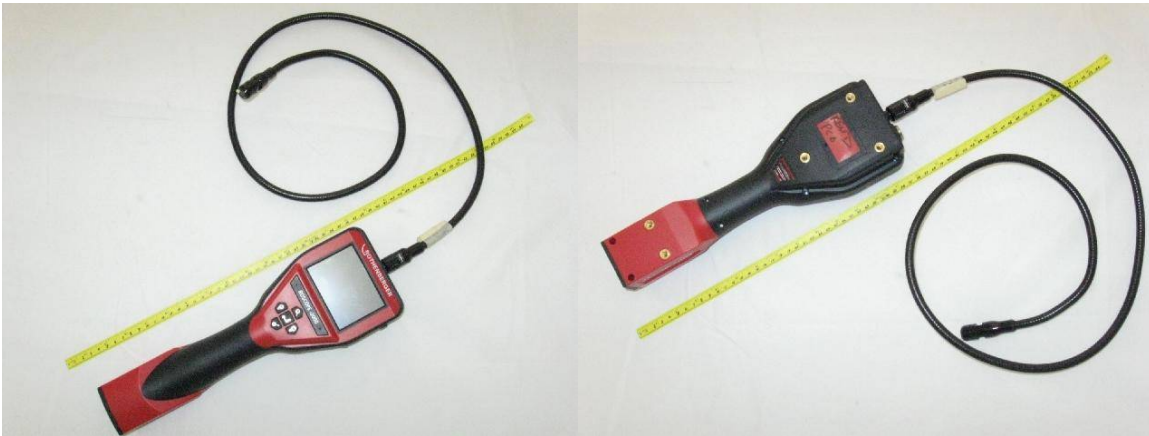

Figure 1: Photos of EUT.

Table 2: EUT Declarations.

General Declarations			
Equipment Type:	Inspection Tool	Country of Origin:	USA
Nominal Supply:	3.7 VDC	Oper. Temp Range:	-20° C to +55° C
Frequency Range:	2412-2472 MHz	Antenna Dimension:	Not Applicable
Antenna Type:	chip	Antenna Gain:	-6.9 dBi (meas.)
Number of Channels:	4	Channel Spacing:	20 MHz
Alignment Range:	Not Applicable	Type of Modulation:	OFDM
United States			
FCC ID Number:	2AADC-INS001	Classification:	DSS
Canada			
IC Number:	11124A-INS001	Classification:	Spread Spectrum Device, Digital Device

2.1.1 EUT Configuration

The EUT is configured for testing as depicted in Figure 2.

2.1.2 Modes of Operation

The EUT is capable of displaying live video images from the equipped camera snake onto its LCD display or broadcasting these images via its 2.4 GHz DSS radio modem to a dedicated receive device. The EUT is also capable of taking snapshot images or video and storing them to its internal memory drive, which can then later be transferred via USB to a commercial computer. In normal use there is only a single mode of radio operation, as an DSS video transmitter at fixed data rate, as tested.

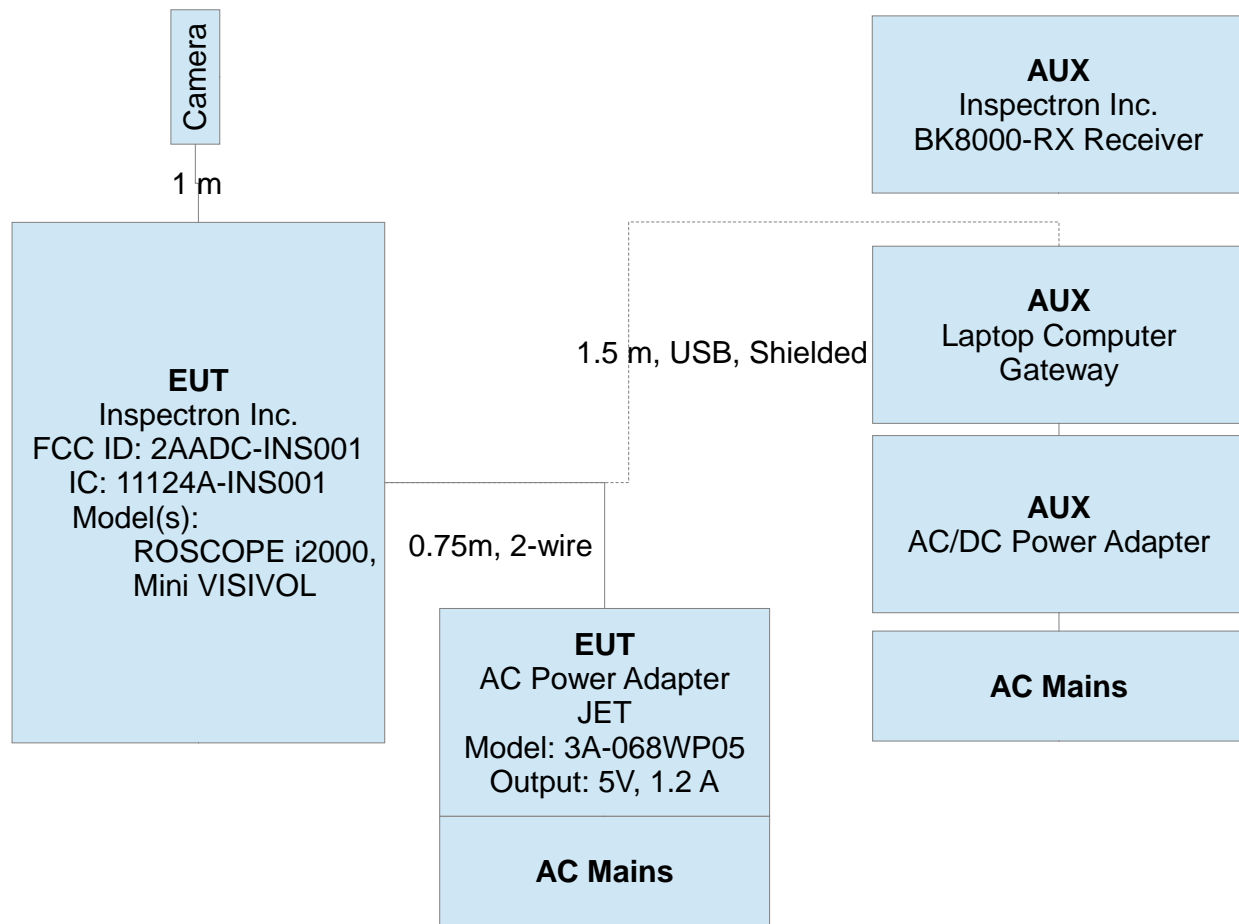

Figure 2: EUT Test Configuration Diagram.

2.1.3 Variants

There are two electrically identical variants of the EUT manufactured for two different tool suppliers, model "ROSCOPE i2000" and model "Mini VISIOVAL".

2.1.4 Test Samples

Two samples in total were provided. One sample capable of normal operation with production software. One sample with custom continuous modulated transmit and receive software.

2.1.5 Functional Exerciser

For RF testing, the radio was placed into the maximum possible (continuous) data rate and maximum power setting using custom software provided by the radio manufacturer. The normal operating EUT was tested for functionality as a video camera and a memory storage device during digital emissions testing. Camera performance was monitored by observing the video quality (i.e. color, resolution, etc...) and communication between the camera head, the display, and a separate image receiver. A music file was loaded onto the EUT via USB to a laptop computer. The music file was continuously played via a media player on the laptop (set to continuous play) during testing.

2.1.6 Modifications Made

There were no modifications made to the EUT by this laboratory. Preliminary measurements made of the EUT indicated that changes to antenna tuning were necessary to bring the device into proper operation. Changes to the antenna tuning were made by the manufacturer.

2.1.7 Production Intent

The EUT appears to be a production ready sample.

2.1.8 Declared Exemptions and Additional Product Notes

The EUT employs only a single-stream fixed data rate communication on 4 selectable channels (2412 MHz, 2432 MHz, 2452 MHz, and 2472 MHz). The radio parameters cannot be adjusted by the end user and the EUT communicates only with an associated BK8000-RX receiver. In addition, this is an expensive product sold only through industrial plumbing outlets for use by trained and certified plumbers. As such, it is subject to digital emissions regulation as a Class A commercial product. The manufacturer states that it will not be sold for use by the general public.

3 Emissions

3.1 General Test Procedures

3.1.1 Radiated Test Setup and Procedures

Radiated electromagnetic emissions from the EUT are first evaluated in our shielded fully anechoic chamber. Spectrum and modulation characteristics of all emissions are recorded, and emissions above 1 GHz are fully characterized. The anechoic chamber contains a set-up similar to that of our outdoor 3-meter site, with a turntable and antenna mast. Instrumentation, including spectrum analyzers and other test equipment as detailed in Section 1.2 are employed. After indoor pre-scans, emission measurements are made on our outdoor 3-meter Open Area Test Site (OATS). If the EUT connects to auxiliary equipment and is table or floor standing, the configurations prescribed in ANSI C63.4 / CISPR-22 are followed. Alternatively, a layout closest to normal use (as declared by the provider) is employed if the resulting emissions appear to be worst-case in such a configuration. See Figure 3. All

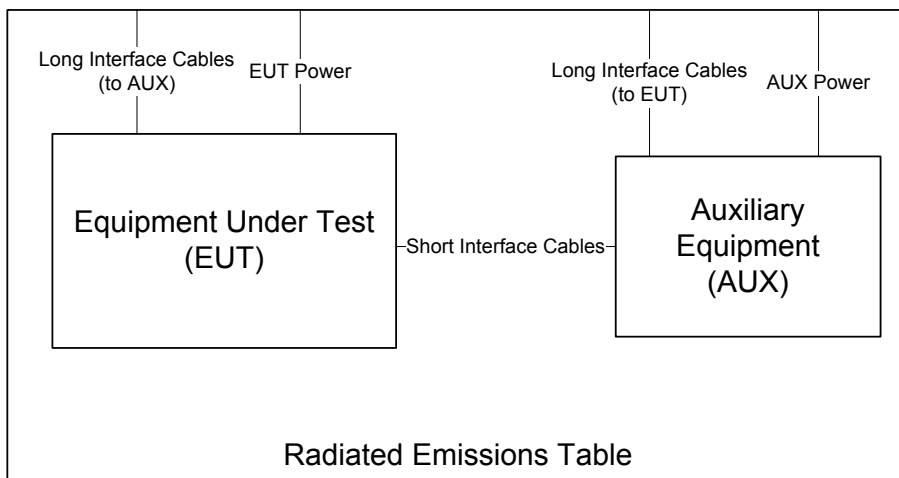

Figure 3: Radiated Emissions Diagram of the EUT.

intentionally radiating elements are placed on the test table lying flat, on their side, and on their end (3-axes) and the resulting worst case emissions are recorded. For both horizontal and vertical polarizations, the test antenna is raised and lowered from 1 to 4 m in height until a maximum emission level is detected. The EUT is then rotated through 360° in azimuth until the highest emission is detected. The test antenna is then raised and lowered one last time from 1 to 4 m and the worst case value is recorded. Photographs of the test setup employed are depicted in Figure 4.

If the EUT exhibits spurious emissions due to internal receiver circuitry, such emissions are measured with an appropriate carrier signal applied. For devices with intentional emissions below 30 MHz, a shielded loop antenna is used as the test antenna. It is placed at a 1 meter receive height and appropriate low frequency magnetic field extrapolation to the regulatory limit distance is employed. Emissions between 30 MHz and 1 GHz are measured using tuned dipoles and/or calibrated broadband antennas. Emissions above 1 GHz are characterized using standard gain horn antennas or calibrated broadband ridge-horn antennas. Care is taken to ensure that test receiver resolution and video bandwidths meet the regulatory requirements, and that the emission bandwidth of the EUT is not reduced.

Where regulations allow for direct measurement of field strength, power values (dBm) measured on the test receiver / analyzer are converted to dBµV/m at the regulatory distance, using

$$E_{dist} = 107 + P_R + K_A - K_G + K_E - C_F$$

where P_R is the power recorded on spectrum analyzer, in dBm, K_A is the test antenna factor in dB/m, K_G is the combined pre-amplifier gain and cable loss in dB, K_E is duty correction factor (when applicable) in dB, and C_F is a distance conversion (employed only if limits are specified at alternate distance) in dB. This field strength value is then compared with the regulatory limit. If effective isotropic radiated power (EIRP) is compute, it is computed as

$$EIRP(dBm) = E_{3m}(dBµV/m) - 95.2.$$

When presenting data at each frequency, the highest measured emission under all possible EUT orientations (3-axes) is reported.



Figure 4: Radiated Emissions Test Setup Photograph(s).

3.1.2 Conducted Emissions Test Setup and Procedures

Transmit Antenna Port Conducted Emissions At least one sample EUT supplied for testing was provided with a 50 Ω antenna port. Conducted transmit chain emissions measurements (where applicable) are made by connecting the EUT antenna port directly to the test receiver port. Photographs of the test setup employed are depicted in Figure 5.



Figure 5: Conducted RF Test Setup Photograph(s).

AC Port Conducted Spurious For this device, AC power line conducted emissions are measured in our screen room. If the EUT connects to auxiliary equipment and is table or floor standing, the configurations prescribed in ANSI C63.4 / CISPR 22 are employed. Alternatively, an on-table layout more representative of actual use may be employed if the resulting emissions appear to be worst-case in such a configuration. See Figure 6. Conducted emissions are measured and recorded for each AC mains power source over the spectrum 0.15 MHz to 30 MHz for both the ungrounded (HI/PHASE) and grounded (LO/GRND) conductors with the EUT placed in its highest current draw operating mode(s). The test receiver is set to peak-hold mode in order to record the peak emissions throughout the course of functional operation. Only if an emission exceeds or is near the limit are quasi-peak and average detection applied. Photographs of the test setup employed are depicted in Figure 7.

3.1.3 Power Supply Variation

Tests at extreme supply voltages are made if required by the the procedures specified in the test standard, and results of this testing are detailed in this report.

In the case of this EUT, measurements of the worst-case radiated emissions are performed with the supply voltage varied by no less than 85% and 115% of the nominal rated value for devices connecting to AC power mains.

In the case the EUT is designed for operation from a lead-acid battery power source, the extreme test voltages are evaluated between 90% and 130% of the nominal battery voltage declared by the manufacturer. For float charge applications using gel-cell type batteries, extreme test voltages are evaluated between 85% and 115% of the nominal battery voltage declared. For all battery operated equipment, worst case intentional and spurious emissions are re-checked employing a new (fully charged) battery.

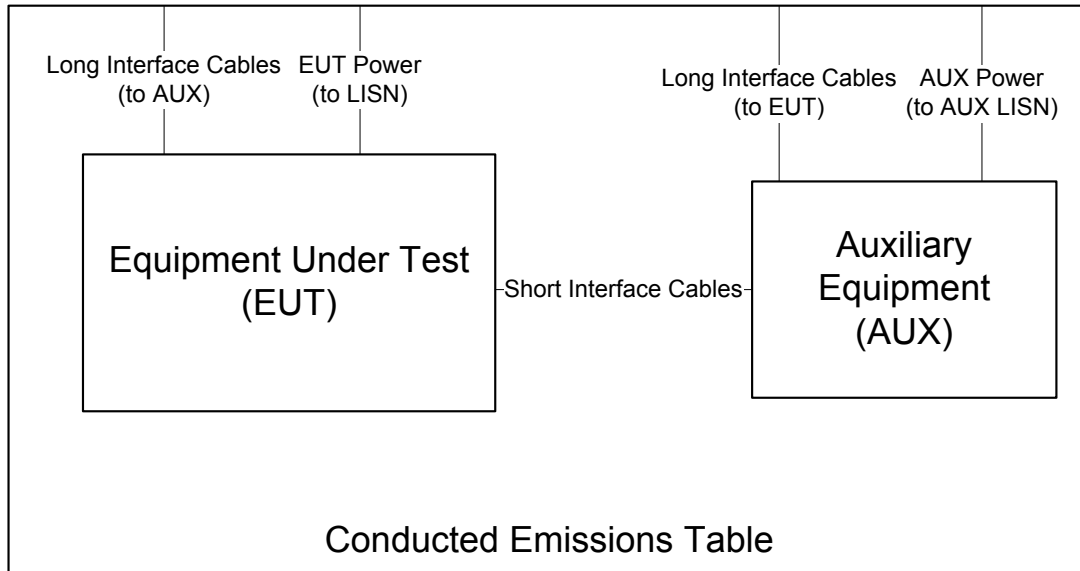

Figure 6: Conducted Emissions Setup Diagram of the EUT.

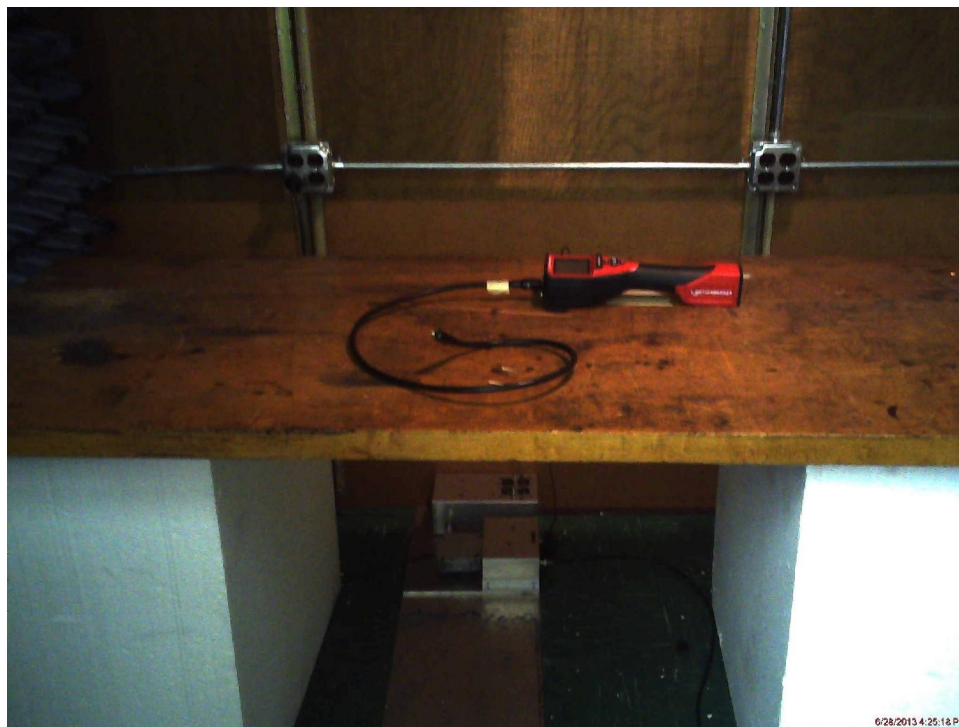

Figure 7: Conducted Emissions Test Setup Photograph(s).

3.1.4 Thermal Variation

Tests at extreme temperatures are made if required by the procedures specified in the test standard, and results of this testing are detailed in this report. The provider has declared that the EUT is designed for operation over the temperature range -20°C to $+55^{\circ}\text{C}$. Before any temperature measurements are made, the equipment is allowed to reach a thermal balance in the test chamber, temperature and humidity are recorded, and thermal balance is verified via a thermocouple based probe.

3.2 Intentional Emissions

3.2.1 Fundamental Emission Bandwidth

Emission bandwidth (EBW) of the EUT is measured with the device placed in the test mode(s) with the shortest available packet length and minimum packet spacing. Radiated emissions are recorded following the test procedures listed in Section 1.1. The 6 dB bandwidth is measured for the lowest, middle, and highest channels available. The 99% emission bandwidth per IC test procedures is also reported. The results of this testing are summarized in Table 3. Plots showing measurements employed obtain the emission bandwidths reported are provided in Figure 8.

Table 3: Intentional Emission Bandwidth.

Frequency Range	Detector	IF Bandwidth	Video Bandwidth	Test Date:	1-Jul-13
f > 1 000 MHz	Pk	30 kHz	> 3 x IFBW	Test Engineer:	Joseph Brunett
				EUT Mode:	i2000

FCC/IC							
Mode	Data Rate	Channel	Frequency (MHz)	6 dB BW (MHz)	20 dB BW (MHz)	26 dB EBW (MHz)	IC 99% PWR BW (MHz)
Cont. Tx	Continuous	1	2412.0	16.58	18.53	20.25	16.73
		2	2432.0	16.58	18.53	19.80	16.73
		4	2472.0	16.58	18.45	19.88	16.8

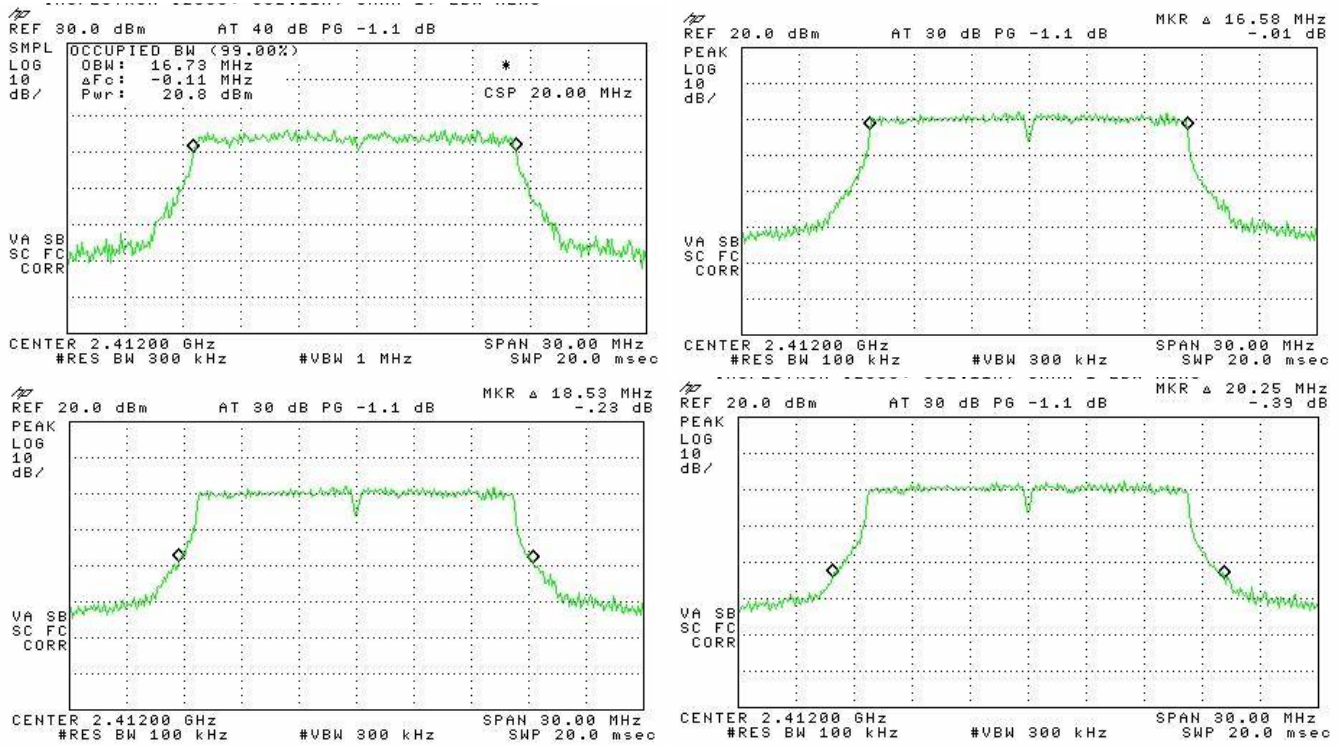

Figure 8(a): Intentional Emission Bandwidth.

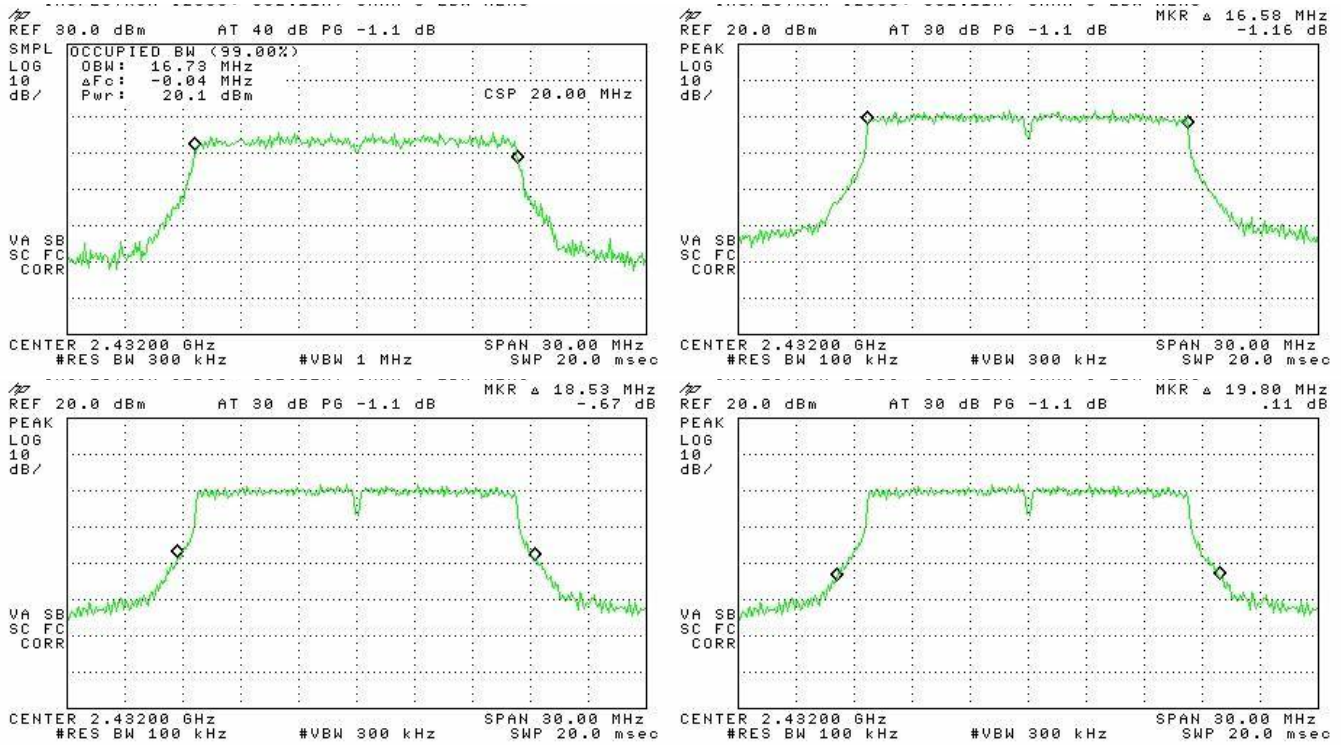

Figure 8(b): Intentional Emission Bandwidth.

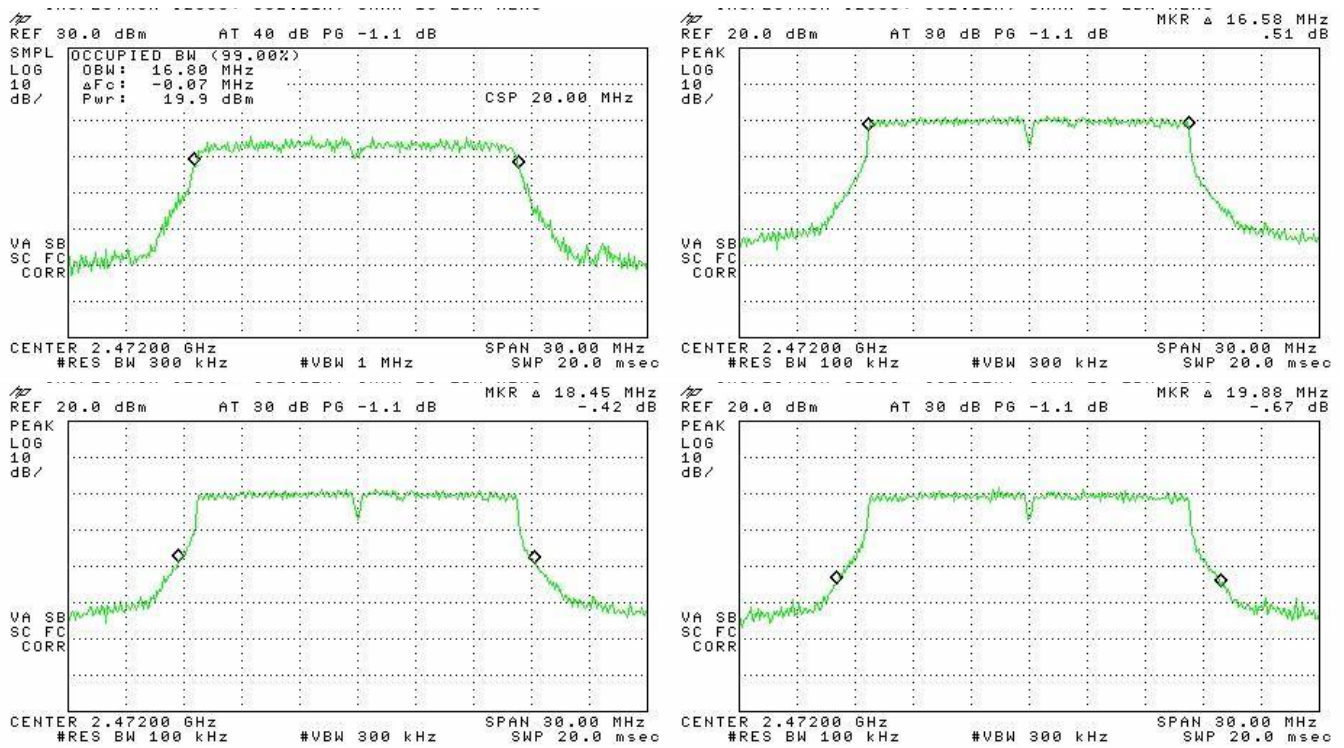

Figure 8(c): Intentional Emission Bandwidth.

3.2.2 Effective Isotropic Radiated Power

The EUT's radiated power is computed from antenna port conducted power measurements and the gain of the EUT antenna(s). Where the EUT is not sold with an antenna connector, a modified product has been provided including such. Since the emission bandwidth of this EUT is greater than the maximum test receiver bandwidth available, Section 9.2.2.2 Method AVGSA-1 (trace averaging with the EUT transmitting at full power throughout each sweep) in the FCC's DTS measurement procedures is employed in determining average output power. The results of this testing are summarized in Table 4. Plots showing the measurements made to obtain these values are provided in Figure 9.

Table 4: Radiated Power Results.

Frequency Range	Det	IF Bandwidth	Video Bandwidth	Test Date:	1-Jul-13
25 MHz f 1 000 MHz	Pk/QPk	120 kHz	300 kHz	Test Engineer:	Joseph Brunett
f > 1 000 MHz	Pk/Avg	1 MHz	3 MHz/10kHz	EUT:	i2000

FCC/IC											
Mode	Channel	Freq. MHz	Ant. Used	Ant. Pol.	Pr ** dBm	Ka dB/m	Kg dB	EIRP (Avg) dBm	Pout* (Avg) dBm	Calc. Ant Gain dBi	EIRP (Avg) Limit dBm
Cont. Tx.	1	2412.0	Horn LS	H/V	-25.0	16.8	-1.2	4.8	12.2	-7.4	30.0
	2	2432.0	Horn LS	H/V	-24.5	16.8	-1.2	5.3	12.2	-6.9	30.0
	4	2472.0	Horn LS	H/V	-25.4	16.8	-1.2	4.4	11.7	-7.3	30.0
Mode	Channel	Freq. MHz	Supply Voltage	Ant. Pol.	Pr ** dBm	Ka dB/m	Kg dB	EIRP (Pk) dBm			
Cont. Tx.	2	2432.0	4.1	H/V	-24.6	16.8	-1.2	5.2			
		2432.0	3.9	H/V	-24.4	16.8	-1.2	5.4			
		2432.0	3.7	H/V	-24.5	16.8	-1.2	5.3			
		2432.0	3.5	H/V	-24.5	16.8	-1.2	5.3			
		2432.0	3.3	H/V	-24.6	16.8	-1.2	5.2			

* Measured conducted from radio port via modified device following FCC's DTS measurement procedures method AVGSA-1.

** Measured radiated at 3 meter distance following FCC's DTS measurement procedures method AVGSA-1.

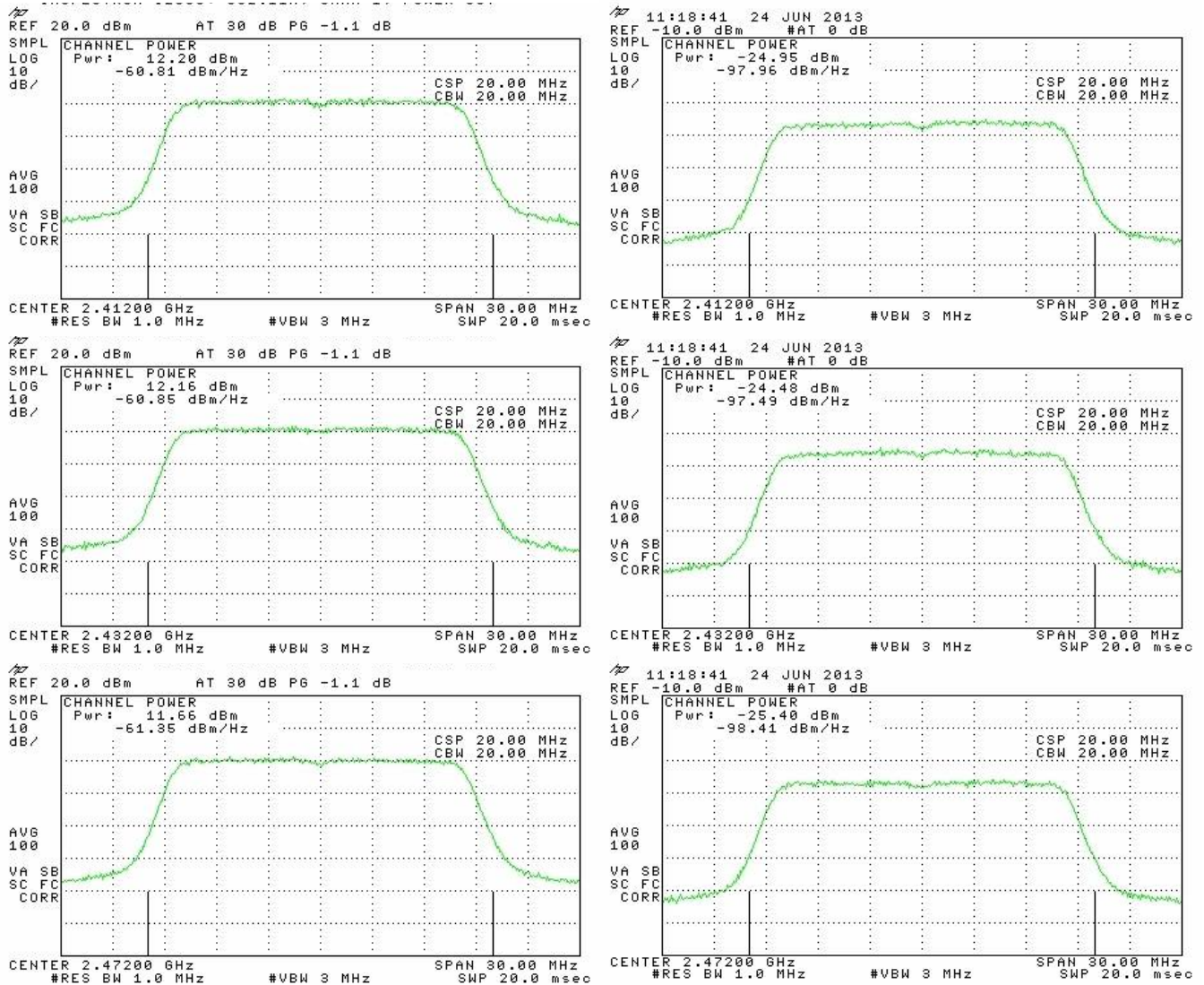

Figure 9: Power Measurement Plots.

3.2.3 Power Spectral Density

For this test, the EUT was attached directly to the test receiver. Following FCC DTS Method PKPSD, the emission spectrum is first scanned for maximum spectral peaks, the span and receiver bandwidth are then reduced until the power spectral density is measured in the prescribed receiver bandwidth. A sweep time of 100 seconds is maintained to ensure peak signals are captured in each frequency bin. The results of this testing are summarized in Table 5. Plots showing how these measurements were made are depicted in Figure 10.

Table 5: Power Spectral Density Results.

Frequency Range	Detector	IF Bandwidth	Video Bandwidth	Test Date:	2-Jul-13
2405-2480 MHz	Pk	3 kHz	300 kHz	Test Engineer:	Joseph Brunett
				EUT:	i2000

FCC/IC								
Mode	Channel	Frequency (MHz)	Ant. Used	Pout (meas) (dBm/3kHz)	Ant. Gain (dBi)	EIRP / PSD (dBm/3kHz)	PSD Limit (dBm/3kHz)	Line Spacing (kHz)
Continuous Tx.	1	2412.0	Horn LS	-11.5	- 6.6	-18.14	8.00	9.7
	2	2432.0	Horn LS	-10.7	- 6.1	-16.81	8.00	11.8
	4	2472.0	Horn LS	-10.6	- 6.5	-17.05	8.00	10.0

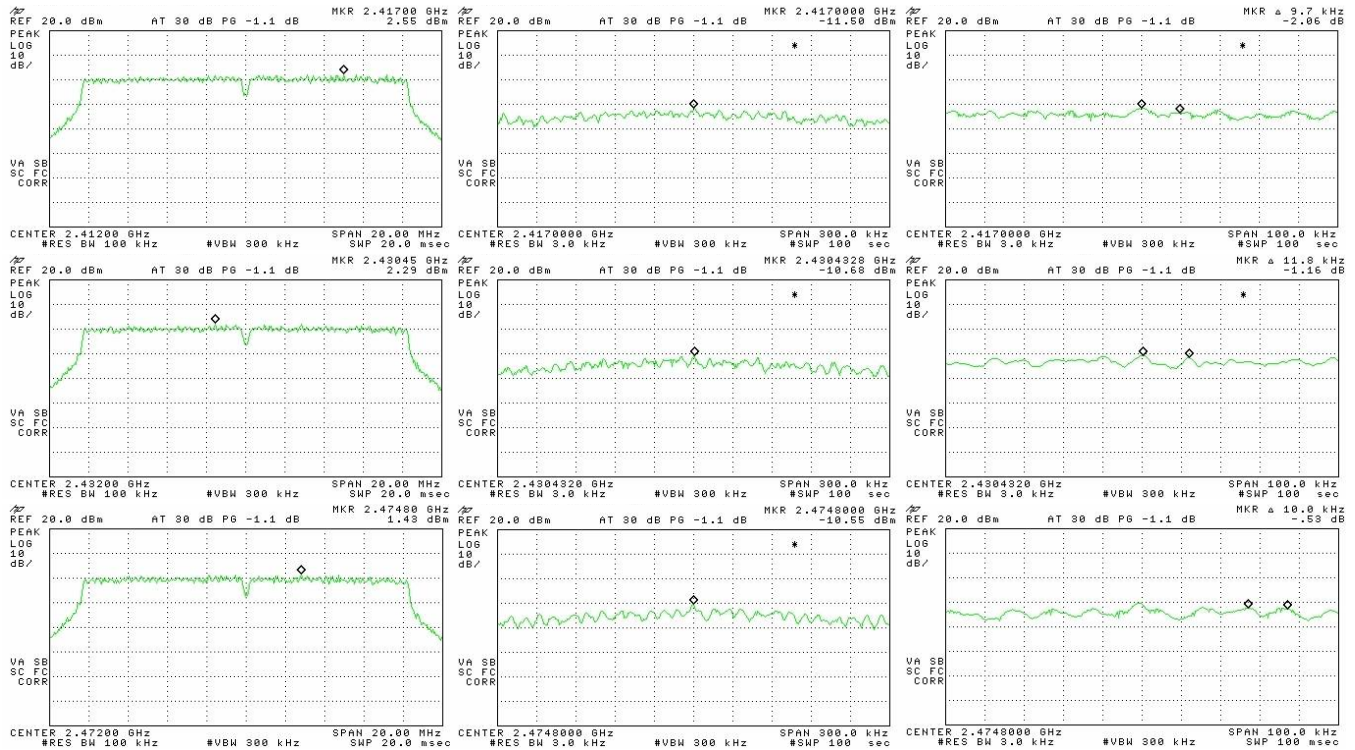

Figure 10: Power Spectral Density Plots.

3.3 Unintentional Emissions

3.3.1 Transmit Chain Spurious Emissions

The results for the measurement of transmit chain spurious emissions at the nominal voltage and temperature are provided in Table 6. Measurements are performed to 10 times the highest fundamental operating frequency.

Table 6: Transmit Chain Spurious Emissions.

Frequency Range		Det	IF Bandwidth	Video Bandwidth	Test Date:		Test Engineer:						
25 MHz f 1 000 MHz		PK/QPk	120 kHz	300 kHz	07/08/2013, 07/19/2013		Joseph Brunett						
f > 1 000 MHz		Pk/Avg	1 MHz	3 MHz/10kHz			EUT: i2000						
							Mode: Continous Tx CH 1,2,4						
Tx Spurious Emissions													FCC/IC
#	Freq. MHz	Ant. Used	Ant. Pol.	Pr (Pk) dBm	Pr (Avg)* dBm	Ka dB/m	Kg dB	E3(Pk) dBµV/m	E3(Avg) dBµV/m	E3 Avg Lim dBµV/m	Pass dB	Comments	
1 Fundamental Restricted Band Edge (Low Side)													
2	2412.0	Horn LS	H/V	-25.1	-37.8	16.8	-1.2	99.9	87.2			CH 1, 2412 MHz; max all	
3	2390.0	Horn LS	H/V	-63.6	-76.3	16.7	-1.2	61.3	48.6	54.0	5.4	CH 1, 2412 MHz; ** See Below	
4	2390.0	Horn LS	H/V	-65.3	-76.3	16.7	-1.2	59.6	48.6	54.0	5.4	CH2, 2432 MHz; max all	
5	2390.0	Horn LS	H/V	-66.7	-78.3	16.7	-1.2	58.2	46.6	54.0	7.4	CH4, 2472 MHz.; max all	
6 Fundamental Restricted Band Edge (High Side)													
7	2483.5	Horn LS	H/V	-65.1	-78.0	16.9	-1.2	60.0	47.1	54.0	6.9	CH 1, 2412 MHz; max all	
8	2483.5	Horn LS	H/V	-64.9	-77.4	16.9	-1.2	60.2	47.7	54.0	6.3	CH2, 2432 MHz; max all	
9	2472.0	Horn LS	H/V	-25.7	-38.4	16.8	-1.2	99.3	86.6			CH4, 2472 MHz.; max all	
10	2483.5	Horn LS	H/V	-58.6	-71.3	16.9	-1.2	66.5	53.8	54.0	0.2	CH4, 2472 MHz.; *** See Below	
11													
12 Harmonic Emissions													
13	4824.0	QR Horn	H/V	-59.9	-72.6	37.9	21.1	63.9	51.2	54.0	2.8	Low, Max all	
14	4864.0	QR Horn	H/V	-58.4	-71.1	38.0	20.9	65.6	52.9	54.0	1.1	Mid, Max all	
15	4944.0	QR Horn	H/V	-58.5	-71.2	38.1	20.7	65.9	53.2	54.0	0.8	High, Max all	
16	7236.0	QR Horn	H/V	-58.6	-70.6	38.2	40.0	46.6	34.6	54.0	19.4	Low, Max all	
17	7296.0	QR Horn	H/V	-59.2	-71.4	38.2	40.0	46.0	33.8	54.0	20.2	Mid, Max all	
18	7416.0	QR Horn	H/V	-58.1	-70.5	38.2	40.0	47.1	34.7	54.0	19.3	High, Max all	
19	9648.0	QR Horn	H/V	-58.3	-70.4	38.3	40.0	47.0	34.9	54.0	19.1	Low, Max all	
20	9728.0	QR Horn	H/V	-59.8	-70.5	38.3	40.0	45.5	34.8	54.0	19.2	Mid, Max all	
21	9888.0	QR Horn	H/V	-58.3	-70.9	38.3	40.0	47.0	34.4	54.0	19.6	High, Max all	
22	12060.0	QR Horn	H/V	-75.0	-87.7	37.8	40.0	29.8	17.1	54.0	36.9	Low, noise; max all	
23	12160.0	QR Horn	H/V	-75.0	-87.7	37.8	40.0	29.8	17.1	54.0	36.9	Mid, noise; max all	
24	12360.0	QR Horn	H/V	-75.0	-87.7	37.7	40.0	29.7	17.0	54.0	37.0	High, noise; max all	
25	14472.0	QR Horn	H/V	-75.0	-87.7	37.0	40.0	29.0	16.3	54.0	37.7	Low, noise; max all	
26	14592.0	QR Horn	H/V	-75.0	-87.7	36.9	40.0	28.9	16.2	54.0	37.8	Mid, noise; max all	
27	14832.0	QR Horn	H/V	-75.0	-87.7	36.8	40.0	28.8	16.1	54.0	37.9	High, noise; max all	
28	16884.0	QR Horn	H/V	-75.0	-87.7	35.9	40.0	27.9	15.2	54.0	38.8	Low, noise; max all	
29	17024.0	QR Horn	H/V	-75.0	-87.7	35.8	40.0	27.8	15.1	54.0	38.9	Mid, noise; max all	
30	17304.0	QR Horn	H/V	-75.0	-87.7	35.7	40.0	27.7	15.0	54.0	39.0	High, noise; max all	
31	19296.0	Horn K	H/V	-61.3	-74.0	32.2	35.0	42.9	30.2	54.0	23.8	Low, noise; max all	
32	19456.0	Horn K	H/V	-60.3	-73.0	32.3	35.0	44.0	31.3	54.0	22.7	Mid, noise; max all	
33	19776.0	Horn K	H/V	-60.1	-72.8	32.3	35.0	44.2	31.5	54.0	22.5	High, noise; max all	
34	21708.0	Horn K	H/V	-57.6	-70.3	32.7	35.0	47.1	34.4	54.0	19.6	Low, noise; max all	
35	21888.0	Horn K	H/V	-57.1	-69.8	32.7	35.0	47.6	34.9	54.0	19.1	Mid, noise; max all	
36	22248.0	Horn K	H/V	-56.9	-69.6	32.8	35.0	47.9	35.2	54.0	18.8	High, noise; max all	
37	24120.0	Horn K	H/V	-54.3	-67.0	33.2	35.0	50.9	38.2	54.0	15.8	Low, noise; max all	
38	24320.0	Horn K	H/V	-54.1	-66.8	33.2	35.0	51.1	38.4	54.0	15.6	Mid, noise; max all	
39	24720.0	Horn K	H/V	-55.3	-68.0	33.3	35.0	50.0	37.3	54.0	16.7	High, noise; max all	

*QPk detection below 1 GHz, Avg detection at or above 1 GHz with receiver bandwidth as specified at top of table.

** Avg. meas. via "delta method", with intentional emm. meas. in 1MHz IFBW, band-edge delta in 300kHz IFBW. SPAN 27 MHz.

*** Avg. meas. via "delta method", with intentional emm. meas. in 1MHz IFBW, band-edge delta in 120kHz IFBW. SPAN 12 MHz.

3.3.2 Radiated Receiver Spurious

The results for the measurement of radiated receiver spurious emissions (emissions from the receiver chain, e.g. LO or VCO) at the nominal voltage and temperature are reported in Table 7. Receive chain emissions are measured to 5 times the highest receive chain frequency observed, or 4 GHz, whichever is higher. If no emissions are detected, only those noise floor emissions at the LO/VCO frequency are reported.

Table 7: Receiver Chain Spurious Emissions \geq 30 MHz.

Frequency Range	Det	IF Bandwidth	Video Bandwidth	Test Date:	2-Jul-13
25 MHz \leq f \leq 1 000 MHz	Pk/QPk	120 kHz	300 kHz	Test Engineer:	Joseph Brunett
f > 1 000 MHz	Pk/Avg	1 MHz	3 MHz/10kHz	EUT Mode:	Receive Only - Standby

Receive Chain Spurious Emissions													FCC/IC
#	Freq. MHz	Ant. Used	Ant. Pol.	Pr (Pk) dBm	Pr (QPk/Avg) dBm*	Ka dB/m	Kg dB	E3(Pk) dB μ V/m	E3(Avg) dB μ V/m	FCC/IC E3lim dB μ V/m	CE E3lim dB μ V/m	Pass dB	Comments
1	2372.0	Horn LS	H/V	-75.1		16.7	-1.2	49.8		54.0		4.2	max all, noise
2	2392.0	Horn LS	H/V	-75.7		16.7	-1.2	49.2		54.0		4.8	max all, noise
3	2432.0	Horn LS	H/V	-75.2		16.8	-1.2	49.8		54.0		4.2	max all, noise
4	2452.0	Horn LS	H/V	-76.2		16.8	-1.2	48.8		54.0		5.2	max all, noise
5	2472.0	Horn LS	H/V	-76.6		16.8	-1.2	48.4		54.0		5.6	max all, noise
6	2512.0	Horn LS	H/V	-75.9		16.9	-1.2	49.2		54.0		4.8	max all, noise
7	NOTE: VCO/LO is 40 MHz offset from Rx Channel. Low, Middle and High Channels tested.												
8													
9													
10													
11													
12													
13													
14													
15													
16													

*QPk detection below 1 GHz, Avg detection at or above 1 GHz with receiver bandwidth as specified at top of table.

3.3.3 Radiated Digital Spurious

The results for the measurement of digital spurious emissions (emissions arising from digital circuitry) at the nominal voltage and temperature are provided in Table 8. Radiation from digital components has been measured to 4 GHz, or to five times the maximum digital component operating frequency, whichever is greater.

Table 8: Radiated Digital Spurious Emissions.

Frequency Range	Det	IF Bandwidth	Video Bandwidth	Test Date:	24-Jun-13
25 MHz f 1 000 MHz	Pk/QPk	120 kHz	300 kHz	Test Engineer:	Joseph Brunett
f > 1 000 MHz	Pk	1 MHz	3 MHz	EUT Mode:	Bartech Tech500 + AUX PC, + AC Power Converter
f > 1 000 MHz	Avg	1 MHz	10kHz	Meas. Distance:	3 meters

Digital Spurious Emissions																	FCC/IC + CE(CISPR)	
#	Test Freq. MHz	Antenna		Pr (Pwr Rx.)		Ka dB/m	Kg dB	E-Field @ 3m		FCC/IC Class B		CE Class B		FCC/IC Class A		CE Class A		Comments
		Type Used	Test Pol.	Pk dBm	QPk/Avg dBm*			Pk dBuV/m	QPk/Avg dBuV/m	E3lim dBuV/m	Pass dB	E3lim dBuV/m	Pass dB	E3lim dBuV/m	Pass dB	E3lim dBuV/m	Pass dB	
1	49.5	Bic	H	-52.8	-55.1	9.2	40.5	22.9		40.0	17.1	40.5	17.6	49.5	26.6	50.5	27.6	
2	58.4	Bic	H	-43.7	-46.2	8.2	40.3	31.2		40.0	8.8	40.5	9.3	49.5	18.3	50.5	19.3	
3	67.6	Bic	H	-43.9	-49.3	7.7	40.1	30.7		40.0	9.3	40.5	9.8	49.5	18.8	50.5	19.8	
4	76.5	Bic	H	-37.7	-40.1	7.5	39.9	37.0		40.0	3.0	40.5	3.5	49.5	12.5	50.5	13.5	
5	84.2	Bic	H	-41.8	-43.0	7.7	39.7	33.2		40.0	6.8	40.5	7.3	49.5	16.3	50.5	17.3	
6	84.2	Bic	V	-44.9	-45.7	7.7	39.7	30.1		40.0	9.9	40.5	10.4	49.5	19.4	50.5	20.4	
7	112.4	Bic	H	-37.6	-40.3	9.4	39.1	39.6		43.5	3.9	40.5	.9	54.0	14.4	50.5	10.9	
8	112.4	Bic	V	-51.6		9.4	39.1	25.6		43.5	17.9	40.5	14.9	54.0	28.4	50.5	24.9	
9	130.5	Bic	H	-36.9	-39.4	10.9	38.8	42.2		43.5	1.3	40.5	-1.7	54.0	11.8	50.5	8.3	
10	139.5	Bic	H	-34.1	-36.7	11.6	38.6	45.9		43.5	-2.4	40.5	-5.4	54.0	8.1	50.5	4.6	
11	139.5	Bic	H	-49.1		11.6	38.6	30.9		43.5	12.6	40.5	9.6	54.0	23.1	50.5	19.6	
12	157.7	Bic	H	-37.5	-39.5	13.0	38.3	44.2		43.5	-7	40.5	-3.7	54.0	9.8	50.5	6.3	
13	162.4	Bic	H	-39.0	-44.7	13.3	38.2	43.1		43.5	.4	40.5	-2.6	54.0	10.9	50.5	7.4	
14	162.4	Bic	H	-49.1		13.3	38.2	33.0		43.5	10.5	40.5	7.5	54.0	21.0	50.5	17.5	
15	166.4	Bic	H	-40.5	-45.1	13.5	38.1	41.9		43.5	1.6	40.5	-1.4	54.0	12.1	50.5	8.6	
16	184.5	Bic	H	-38.1	-40.6	14.3	37.8	45.4		43.5	-1.9	40.5	-4.9	54.0	8.6	50.5	5.1	
17	215.9	Bic	H	-54.3		14.8	37.3	30.2		43.5	13.3	40.5	10.3	54.0	23.8	50.5	20.3	
18	240.0	Bic	H	-40.9	-40.8	14.7	36.9	43.8		46.0	2.2	47.5	3.7	56.9	13.1	57.5	13.7	
19	288.0	Sbic	H	-40.4	-41.5	17.4	36.3	47.7		46.0	-1.7	47.5	-.2	56.9	9.2	57.5	9.8	
20	300.0	Sbic	H	-40.0	-41.5	17.9	36.1	48.8		46.0	-2.8	47.5	-1.3	56.9	8.1	57.5	8.7	
21	312.4	Sbic	H	-41.1	-42.9	18.4	35.9	48.3		46.0	-2.3	47.5	-.8	56.9	8.6	57.5	9.2	
22	360.0	Sbic	H	-49.7	-50.7	20.0	35.4	42.0		46.0	4.0	47.5	5.5	56.9	14.9	57.5	15.5	
23	456.0	Sbic	H	-42.2	-44.6	22.4	34.3	52.9		46.0	-6.9	47.5	-5.4	56.9	4.0	57.5	4.6	
24	480.0	Sbic	H	-44.4	-45.3	22.9	34.0	51.4		46.0	-5.4	47.5	-3.9	56.9	5.5	57.5	6.1	
25																		
26																		
27																		
28																		
29																		
30																		
31																		

*QPk detection below 1 GHz, Avg detection at or above 1 GHz with receiver bandwidth as specified at top of table.

3.3.4 Conducted Transmitter Spurious

One of the EUT samples provided for testing employs one (or more) external antenna terminals. Measurement of conducted spurious emissions out of such ports at the nominal voltage and temperature were measured in accordance with the regulations. Results of these measurements are provided in Figure 11 below.

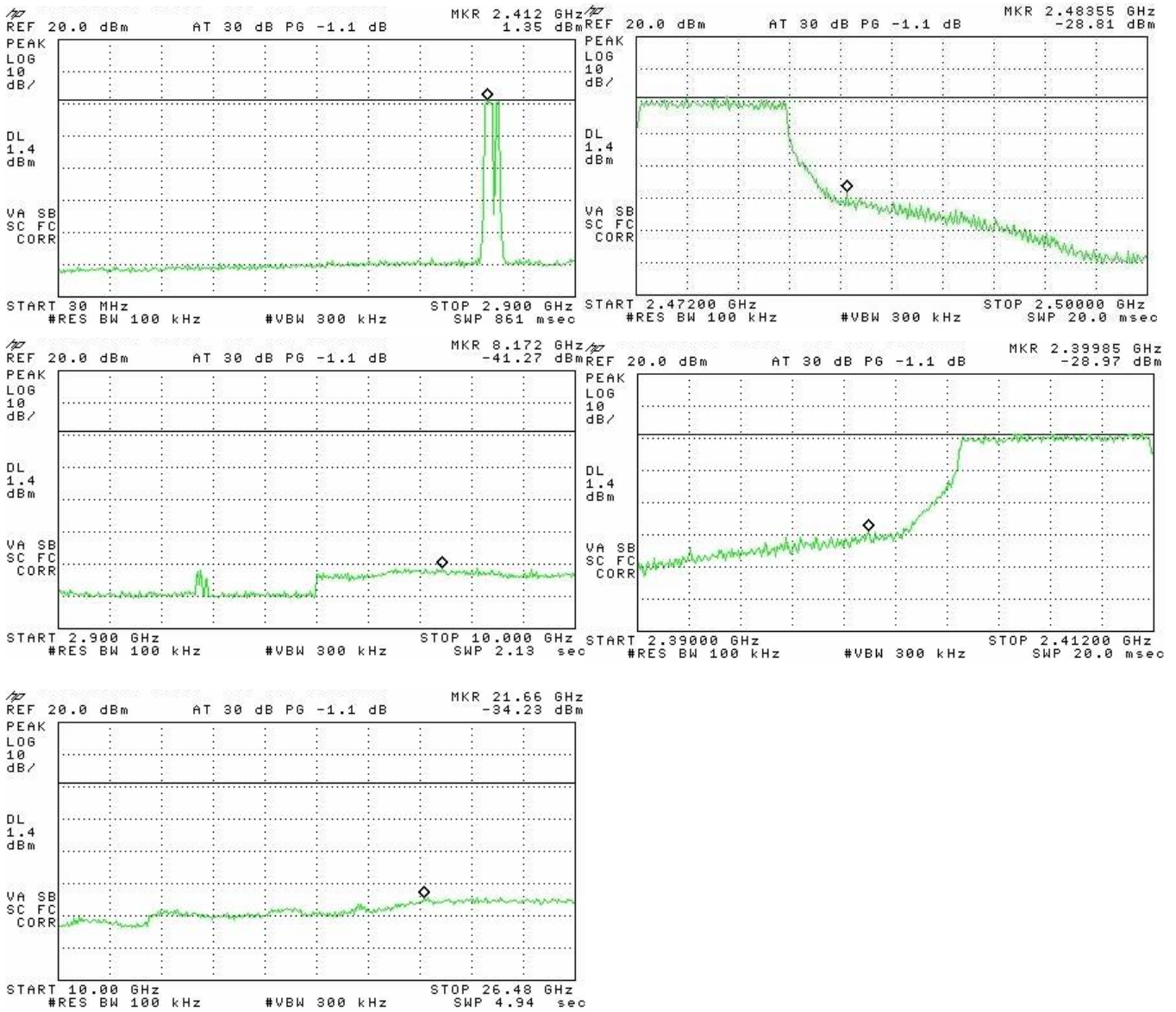

Figure 11: Conducted Receiver Emissions Measured.

3.3.5 Conducted Emissions Test Results - AC Power Port(s)

The results of emissions from the EUT's AC mains power port(s) are reported in Table 9.

Table 9: AC Mains Power Conducted Emissions Results.

Frequency Range 150kHz f 30 MHz
 Det Pk/QPk/Avg
 IF Bandwidth 9 kHz
 Video Bandwidth 30 kHz
 Test Date: 29-Jun-13
Test Engineer: Joseph Brunett
EUT Mode: i2000

AC Mains Power Conducted Emissions														
#	Freq. MHz	Line Side	Vmeas			Class A Qpk		Class A Avg		Class B Qpk		Class B Avg		Comments
			Pk dBuV	Qpk dBuV	Avg dBuV	Vlim* dBuV	Margin dB	Vlim* dBuV	Margin dB	Vlim* dBuV	Margin dB	Vlim* dBuV	Margin dB	
1	0.286	Lo	53.7	52.0	46.8	79.0	27.0	66.0	19.2	60.7	8.7	50.6	3.8	
2	0.457	Lo	46.1	44.3	37.8	79.0	34.7	66.0	28.2	56.8	12.5	46.7	8.9	
3	0.478	Lo	46.0	44.5	38.2	79.0	34.5	66.0	27.8	56.4	11.9	46.3	8.1	
4	0.572	Lo	48.1	43.2	34.7	73.0	29.8	60.0	25.3	56.0	12.8	46.0	11.3	
5	0.577	Lo	47.7	42.4	33.3	73.0	30.6	60.0	26.7	56.0	13.6	46.0	12.7	
6	0.765	Lo	43.9	42.0	34.5	73.0	31.0	60.0	25.5	56.0	14.0	46.0	11.5	
7	0.767	Lo	44.0	41.3	32.9	73.0	31.7	60.0	27.1	56.0	14.7	46.0	13.1	
8	0.804	Lo	43.8	41.3	33.6	73.0	31.7	60.0	26.4	56.0	14.7	46.0	12.4	
9	1.094	Lo	43.7	40.7	33.1	73.0	32.3	60.0	26.9	56.0	15.3	46.0	12.9	
10	1.109	Lo	44.2	40.2	32.2	73.0	32.8	60.0	27.8	56.0	15.8	46.0	13.8	
11	1.420	Lo	42.6	39.6	31.9	73.0	33.4	60.0	28.1	56.0	16.4	46.0	14.1	
12	2.210	Lo	39.6			73.0	33.4	60.0	20.4	56.0	16.4	46.0	6.4	
13	6.123	Lo	27.2			73.0	45.8	60.0	32.8	60.0	32.8	50.0	22.8	
14	13.279	Lo	26.2			73.0	46.8	60.0	33.8	60.0	33.8	50.0	23.8	
15	28.000	Lo	24.9			73.0	48.1	60.0	35.1	60.0	35.1	50.0	25.1	
16														
17														
18	0.288	Hi	53.7	52.3	45.5	79.0	26.7	66.0	20.5	60.6	8.3	50.5	5.0	
19	0.290	Hi	53.7	52.3	45.4	79.0	26.7	66.0	20.6	60.5	8.2	50.5	5.1	
20	0.455	Hi	44.9	41.7	34.4	79.0	34.1	66.0	31.6	56.8	11.9	46.7	12.3	
21	0.579	Hi	47.5	43.0	33.7	73.0	30.0	60.0	26.3	56.0	13.0	46.0	12.3	
22	0.651	Hi	44.0	38.2	27.7	73.0	34.8	60.0	32.3	56.0	17.8	46.0	18.3	
23	0.653	Hi	43.5	39.0	28.4	73.0	34.0	60.0	31.6	56.0	17.0	46.0	17.6	
24	0.689	Hi	42.4	38.0	27.7	73.0	35.0	60.0	32.3	56.0	18.0	46.0	18.3	
25	0.834	Hi	42.9	40.4	33.0	73.0	32.6	60.0	27.0	56.0	15.6	46.0	13.0	
26	1.164	Hi	42.8	39.4	31.7	73.0	33.6	60.0	28.3	56.0	16.6	46.0	14.3	
27	1.476	Hi	41.3	37.5	29.2	73.0	35.5	60.0	30.8	56.0	18.5	46.0	16.8	
28	1.690	Hi	40.3	33.8	23.2	73.0	39.2	60.0	36.8	56.0	22.2	46.0	22.8	
29	2.350	Hi	38.7			73.0	34.4	60.0	21.4	56.0	17.4	46.0	7.4	
30	13.180	Hi	25.1			73.0	47.9	60.0	34.9	60.0	34.9	50.0	24.9	
31	27.984	Hi	26.1			73.0	46.9	60.0	33.9	60.0	33.9	50.0	23.9	
32														
33														
34														
35														
36														
37														
38														
39														
40														
41														
42														
40														

*In all cases, VPk VQpk VAve. If VPk < Vavg limit, then VQPk limit and Vavg limit are met.