



FCC TEST REPORT

FCC ID: 2AAD8-U1291

On Behalf of

HAOLIYUAN (SHENZHEN) ELECTRONIC CO., LTD

802.11ac Wireless USB Adapter

Model No.: Please read page 6

Prepared for : HAOLIYUAN (SHENZHEN) ELECTRONIC CO., LTD
Address : 3/F, Building A1, Junfeng Industrial Park Yonghe Road,
Fuyong, Bao'an District, Shenzhen, Guangdong, China

Prepared By : Shenzhen Alpha Product Testing Co., Ltd.
Address : Building i, No.2, Lixin Road, Fuyong Street, Bao'an
District, 518103, Shenzhen, Guangdong, China

Report Number : T1881361 02
Date of Receipt : August 28, 2018
Date of Test : August 28, 2018 - September 17, 2018
Date of Report : September 17, 2018
Version Number : REV0

Contents

	Page
1 TEST SUMMARY	5
1.1 MEASUREMENT UNCERTAINTY	5
2 GENERAL INFORMATION	6
2.1 GENERAL DESCRIPTION OF EUT	6
2.2 TEST MODE	7
2.3 TEST FACILITY	7
2.4 ACCESSORIES OF DEVICE (EUT)	7
2.5 TESTED SUPPORTING SYSTEM DETAILS	7
3 TEST INSTRUMENTS LIST	8
4 TEST RESULTS AND MEASUREMENT DATA	9
4.1 CONDUCTED EMISSIONS	9
4.2 EMISSION BANDWIDTH AND 99% OCCUPIED BANDWIDTH	12
4.3 PEAK TRANSMIT POWER	20
4.4 POWER SPECTRAL DENSITY	25
4.5 BAND EDGE	40
4.6 RADIATED EMISSION	50
5 FREQUENCY STABILITY	58
6 TEST SETUP PHOTO	60
7 EUT CONSTRUCTIONAL DETAILS	62

TEST REPORT DECLARATION

Applicant : HAOLIYUAN (SHENZHEN) ELECTRONIC CO., LTD
 Address : 3/F, Building A1, Junfeng Industrial Park Yonghe Road, Fuyong,
 Bao' an District, Shenzhen, Guangdong, China
 Manufacturer : HAOLIYUAN (SHENZHEN) ELECTRONIC CO., LTD
 Address : 3/F, Building A1, Junfeng Industrial Park Yonghe Road, Fuyong,
 Bao' an District, Shenzhen, Guangdong, China
 EUT Description : 802.11ac Wireless USB Adapter
 (A) Model No. : Please read page 6
 (B) Trademark : N/A

Measurement Standard Used:
FCC CFR Title 47 Part 15 Subpart E Section 15.407:2017

The device described above is tested by Shenzhen Alpha Product Testing Co., Ltd. to determine the maximum emission levels emanating from the device. The maximum emission levels are compared to the FCC Part 15 Subpart C limits both conducted and radiated emissions. The test results are contained in this test report and Shenzhen Alpha Product Testing Co., Ltd. is assumed of full responsibility for the accuracy and completeness of these tests.

After the test, our opinion is that EUT compliance with the requirement of the above standards.

This report applies to above tested sample only. This report shall not be reproduced in parts without written approval of Shenzhen Alpha Product Testing Co., Ltd.

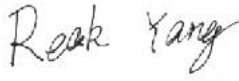
Tested by (name + signature).....: Reak Yang 
 Project Engineer

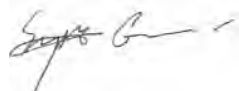
Approved by (name + signature).....: Simple Guan 
 Project Manager

Date of issue.....: September 17, 2018

Revision History

Revision	Issue Date	Revisions	Revised By
00	September 17, 2018	Initial released Issue	Simple Guan

1 Test Summary

Test Item	Section in CFR 47	Result
Antenna requirement	15.203	PASS
AC Power Line Conducted Emission	15.207	PASS
Peak Transmit Power	15.407(a)(1)	PASS
Power Spectral Density	15.407(a)(1)	PASS
Undesirable Emission	15.407(b)(6), 15.205/15.209	PASS
Radiated Emission	15.205/15.209	PASS
Band Edge	15.205	PASS
Frequency Stability	15.407(g)	PASS

Remark:

Pass: The EUT complies with the essential requirements in the standard.

Frequency Stability : The manufacturer stated in the user's manual.

1.1 Measurement Uncertainty

Test Item	Frequency Range	Measurement Uncertainty	Notes
Radiated Emission	9kHz ~ 30MHz	± 4.34dB	(1)
Radiated Emission	30MHz ~ 1000MHz	± 4.24dB	(1)
Radiated Emission	1GHz ~ 40GHz	± 4.68dB	(1)
AC Power Line Conducted Emission	0.15MHz ~ 30MHz	± 3.45dB	(1)

Note (1): The measurement uncertainty is for coverage factor of k=2 and a level of confidence of 95%.

Remark: Test according to ANSI C63.10:2013

2 General Information

2.1 General Description of EUT

Description	: 802.11ac Wireless USB Adapter
Model Number	: U1291, LD0-1200M, FX12000726H, ANEW-1200M WIFI-EU, HLY5DBI-CA, 1200M WiFi-001, B07F6D7DH8, 5dBi-1200, ANE1200WIFI-EU, XC01200WIFI-868, AMB1200WIFI-006, XM-5dBi-1200, XM1200-WIFI-USB
Diff	: There is no difference between all the models, except the Appearance industrial design and model number, this report performs the model U1291.
Trademark	: N/A
Test Voltage	: DC 5V by SUB Port
Operation frequency	: 802.11a/n(HT20)/ac(HT20): 5180~5240MHz; 5745~5825MHz 802.11n(HT40)/ac(HT40): 5190~5230MHz; 5755~5795MHz 802.11ac(HT80): 5210MHz, 5775MHz
Channel separation:	: 802.11a/n(HT20)/ac(HT20): 20MHz; 802.11n(HT40)/ac(HT40): 40MHz 802.11ac(HT80): 80MHz
Modulation type	: CCK/OFDM/DBPSK/DAPSK
Antenna Type	: ANT1: PCB Antenna, Maximum Gain is 2.0dBi ANT2: External Antenna, Maximum Gain is 5.0dBi
Antenna connector	: RP-SMA connector
Software version	: 1030.28
Hardware version	: V1.1

2.2 Test mode

Transmitting mode	Keep the EUT in transmitting with modulation. EUT was test with 99% duty cycle at its maximum power control level.
<i>Remark: During the test, the test voltage was tuned from 85% to 115% of the nominal rated supply voltage, and found that the worst case was under the nominal rated supply condition. So the report just shows that condition's data.</i>	

Channel	Power level
Lowest	5dBm
Middle	5dBm
Highest	5dBm

2.3 Test Facility

Shenzhen Alpha Product Testing Co., Ltd

Building i, No.2, Lixin Road, Fuyong Street, Bao'an District, 518103, Shenzhen, Guangdong, China

June 21, 2018 File on Federal Communication Commission

Registration Number: 293961

July 25, 2017 Certificated by IC

Registration Number: 12135A

2.4 Accessories of Device (EUT)

Accessories1 : /
 Manufacturer : /
 Model : /
 Power supply : /

2.5 Tested Supporting System Details

No.	Description	Manufacturer	Model	Serial Number	Certification or DOC
1	Notebook	ACER	ZQT	N/A	DOC

3 Test Instruments list

Equipment	Manufacture	Model No.	Serial No.	Last cal.	Cal Interval
3m Semi-Anechoic	ETS-LINDGREN	N/A	SEL0017	2017.09.22	1Year
Spectrum analyzer	Agilent	E4407B	MY46185649	2017.09.22	1Year
Receiver	R&S	ESCI	1166.5950K03-1011	2017.09.22	1Year
Receiver	R&S	ESCI	101202	2017.09.22	1Year
Bilog Antenna	Schwarzbeck	VULB 9168	VULB9168-438	2016.09.30	2Year
Horn Antenna	EMCO	3115	640201028-06	2016.09.30	2Year
Active Loop Antenna	Beijing Daze	ZN30900A	SEL0097	2016.09.30	2Year
Cable	Resenberger	N/A	No.1	2017.09.22	1Year
Cable	SCHWARZBECK	N/A	No.2	2017.09.22	1Year
Cable	SCHWARZBECK	N/A	No.3	2017.09.22	1Year
Pre-amplifier	Schwarzbeck	BBV9743	9743-019	2017.09.22	1Year
Pre-amplifier	R&S	AFS33-18002650-30-8P-44	SEL0080	2017.09.22	1Year
Temperature controller	Terchy	MHQ	120	2017.09.22	1Year
L.I.S.N.#1	Schwarzbeck	NSLK8126	8126466	2017.09.22	1Year
L.I.S.N.#2	ROHDE&SCHWARZ	ENV216	101043	2017.09.22	1 Year
20db Attenuator	ICPROBING	IATS1	82347	2017.09.22	1 Year
8-40 Horn Antenna	18-40G antenna	Sas-574	571	2018-3-15	3 Year
Power Meter	Anritsu	ML2487A	6K00001491	2017.09.22	1 Year

4 Test results and Measurement Data

4.1 Conducted Emissions

Test Requirement:	FCC Part15 C Section 15.207														
Test Method:	ANSI C63.10:2013														
Test Frequency Range:	150KHz to 30MHz														
Class / Severity:	Class B														
Receiver setup:	RBW=9KHz, VBW=30KHz														
Limit:	<table border="1"> <thead> <tr> <th rowspan="2">Frequency range (MHz)</th> <th colspan="2">Limit (dBuV)</th> </tr> <tr> <th>Quasi-peak</th> <th>Average</th> </tr> </thead> <tbody> <tr> <td>0.15-0.5</td> <td>66 to 56*</td> <td>56 to 46*</td> </tr> <tr> <td>0.5-5</td> <td>56</td> <td>46</td> </tr> <tr> <td>5-30</td> <td>60</td> <td>50</td> </tr> </tbody> </table>	Frequency range (MHz)	Limit (dBuV)		Quasi-peak	Average	0.15-0.5	66 to 56*	56 to 46*	0.5-5	56	46	5-30	60	50
	Frequency range (MHz)		Limit (dBuV)												
		Quasi-peak	Average												
	0.15-0.5	66 to 56*	56 to 46*												
0.5-5	56	46													
5-30	60	50													
* Decreases with the logarithm of the frequency.															
Test procedure	The E.U.T and simulators are connected to the main power through a line impedance stabilization network(L.I.S.N.). The provide a 50ohm/50uH coupling impedance for the measuring equipment. The peripheral devices are also connected to the main power through a LISN that provides a 50ohm/50uH coupling impedance with 50ohm termination. (Please refers to the block diagram of the test setup and photographs). Both sides of A.C. line are checked for maximum conducted interference. In order to find the maximum emission, the relative positions of equipment and all of the interface cables must be changed according to ANSI C63.10:2013 on conducted measurement.														
Test setup:	<p><i>Remark:</i> E.U.T: Equipment Under Test LISN: Line Impedance Stabilization Network Test table height=0.8m</p>														
Test results:	Pass														

Measurement Data

An initial pre-scan was performed on the line and neutral lines with peak detector. Quasi-Peak and Average measurement were performed at the frequencies with maximized peak emission were detected.

Line:

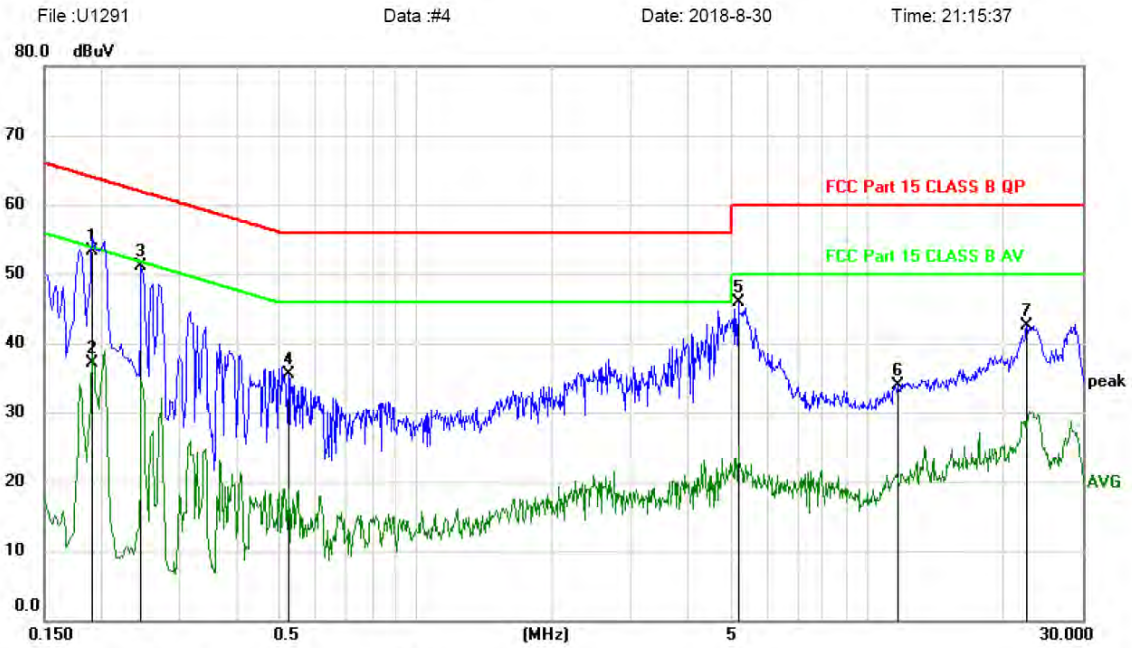

No.	Mk.	Freq. MHz	Reading Level dBuV	Correct Factor dB	Measure- ment dBuV	Limit dBuV	Margin dB	Detector	Comment
1	*	0.1920	43.54	9.74	53.28	63.95	-10.67	QP	
2		0.1920	27.32	9.74	37.06	53.95	-16.89	AVG	
3		0.2459	41.43	9.76	51.19	61.89	-10.70	peak	
4		0.5220	25.72	9.79	35.51	56.00	-20.49	peak	
5		5.1688	35.72	10.20	45.92	60.00	-14.08	peak	
6		11.7027	23.60	10.34	33.94	60.00	-26.06	peak	
7		22.5960	31.90	10.63	42.53	60.00	-17.47	peak	

*:Maximum data x:Over limit !:over margin

Note: Measurement=Reading Level+Correc Factor. Factor=(LISN or ISN or PLC or Current Probe)Factor+Cable

Neutral:

File :U1291

Data :#3

Date: 2018-8-30

Time: 21:10:30

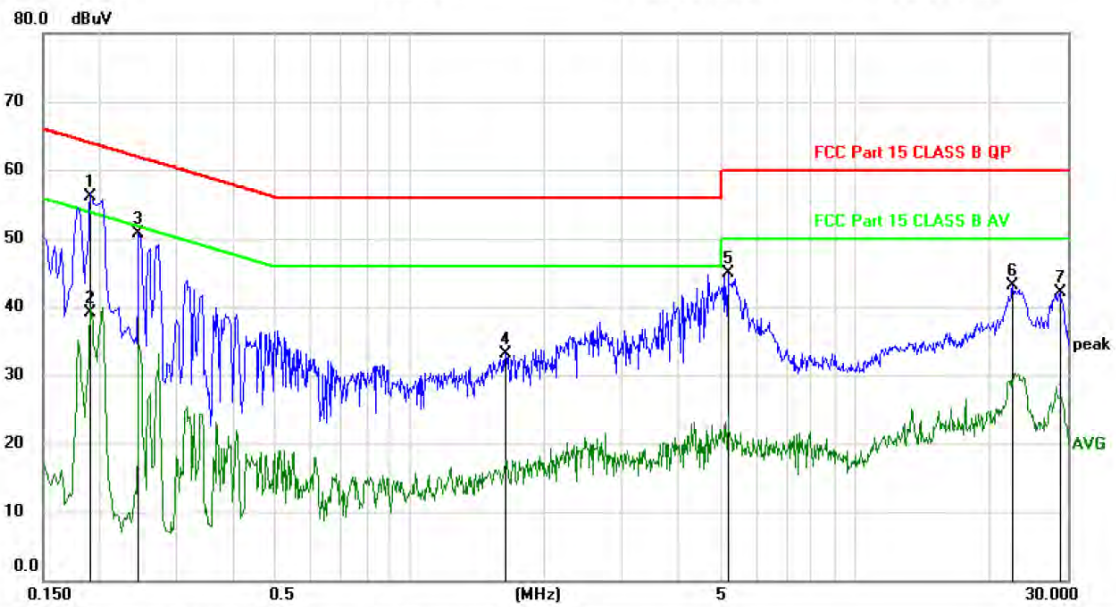

No.	Mk.	Freq. MHz	Reading Level dBuV	Correct Factor dB	Measure- ment dBuV	Limit dBuV	Margin dB	Detector	Comment
1	*	0.1920	46.27	9.74	56.01	63.95	-7.94	QP	
2		0.1920	29.27	9.74	39.01	53.95	-14.94	AVG	
3		0.2460	40.93	9.76	50.69	61.89	-11.20	peak	
4		1.6409	23.15	9.89	33.04	56.00	-22.96	peak	
5		5.1690	34.72	10.20	44.92	60.00	-15.08	peak	
6		22.5960	32.40	10.63	43.03	60.00	-16.97	peak	
7		28.8780	31.09	11.10	42.19	60.00	-17.81	peak	

*:Maximum data x:Over limit !:over margin

Note: Measurement=Reading Level+Correc Factor. Factor=(LISN or ISN or PLC or Current Probe)Factor+Cable

NOTE: Test Result 802.11 n/HT40 (High Channel, ANT1+ANT2), AC 120V/60Hz (Worst Case)

4.2 Emission Bandwidth and 99% Occupied Bandwidth

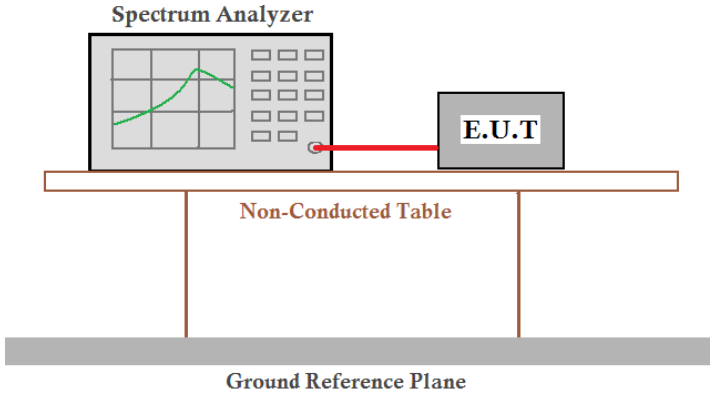
Test Requirement:	FCC Part15 E Section 15.407
Test Method:	KDB 789033 D02 General UNII Test Procedures New Rules v02r01
Limit:	N/A
Test setup:	 <p>The diagram illustrates the test setup. A Spectrum Analyzer is connected to an E.U.T. (Equipment Under Test) via a red cable. Both are placed on a Non-Conducted Table, which is supported by a Ground Reference Plane.</p>
Test procedure:	According to KDB 789033 D02 General UNII Test Procedures New Rules v02r01.
Test results:	Pass <i>Note: Only record the worst case data of ANT 1.</i>

Measurement Data:**Band 1 (5150-5250 MHz):**

CH. No.	Frequency (MHz)	99% Occupied Bandwidth (MHz)			26dB Occupied Bandwidth (MHz)		
		802.11a	802.11n (HT20)	802.11ac (HT20)	802.11a	802.11n (HT20)	802.11ac (HT20)
36	5180.00	17.725	16.713	16.680	21.34	21.46	21.40
40	5200.00	17.698	16.688	16.675	21.45	21.19	20.93
48	5240.00	17.739	16.645	16.648	21.02	20.81	20.39

CH. No.	Frequency (MHz)	99% Occupied Bandwidth (MHz)		26dB Occupied Bandwidth (MHz)	
		802.11n(HT40)	802.11ac(HT40)	802.11n(HT40)	802.11ac(HT40)
38	5190.00	36.401	36.478	48.99	43.55
46	5230.00	36.411	36.376	42.39	44.03

CH. No.	Frequency (MHz)	99% Occupied Bandwidth (MHz)	26dB Occupied Bandwidth (MHz)
		802.11ac(HT80)	802.11ac(HT80)
42	5210.00	75.750	83.68

Band 4 (5725-5850 MHz):

CH. No.	Frequency (MHz)	99% Occupied Bandwidth (MHz)			6dB Occupied Bandwidth (MHz)		
		802.11a	802.11n (HT20)	802.11ac (HT20)	802.11a	802.11n (HT20)	802.11ac (HT20)
149	5745.00	17.982	16.839	18.237	17.15	16.38	16.91
157	5785.00	17.707	16.618	17.741	17.13	15.98	16.95
165	5825.00	17.740	16.622	17.758	16.91	16.31	16.93

CH. No.	Frequency (MHz)	99% Occupied Bandwidth (MHz)		6dB Occupied Bandwidth (MHz)	
		802.11n(HT40)	802.11ac(HT40)	802.11n(HT40)	802.11ac(HT40)
151	5755.00	36.268	36.287	35.43	35.78
159	5795.00	36.018	36.067	35.18	34.61

CH. No.	Frequency (MHz)	99% Occupied Bandwidth (MHz)	6dB Occupied Bandwidth (MHz)
		802.11ac(HT80)	802.11ac(HT80)
155	5775.00	75.349	75.19

Note: Only record the worst case data of ANT 1.

Test plots as followed:

ANT: Band I (5150 - 5250 MHz)

802.11a mode

802.11n(HT20) mode

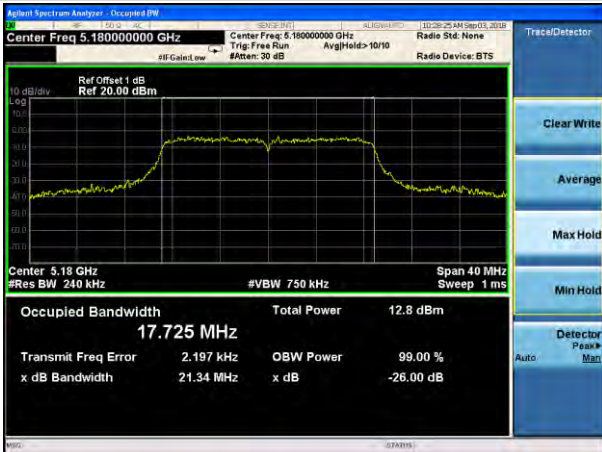

Channel 36 (5180MHz)



Channel 36 (5180MHz)



Channel 40 (5200MHz)



Channel 40 (5200MHz)



Channel 48 (5240MHz)



Channel 48 (5240MHz)

802.11ac(HT20) mode



Channel 36 (5180MHz)



Channel 40 (5200MHz)



Channel 48 (5240MHz)

802.11n(HT40) mode



Channel 38 (5190MHz)

802.11ac(HT40) mode



Channel 38 (5190MHz)

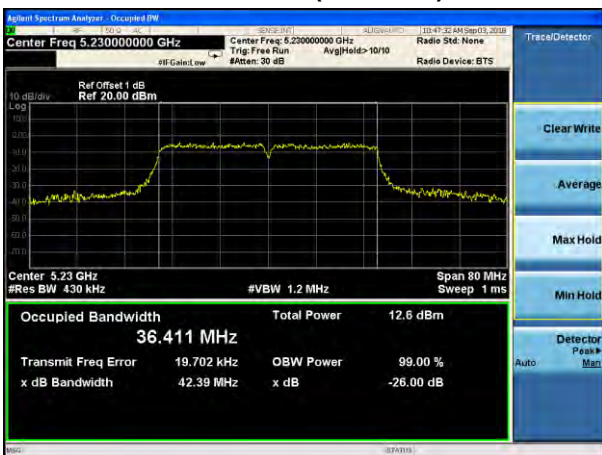

Channel 46 (5230MHz)



Channel 46 (5230MHz)

802.11ac(HT80) mode

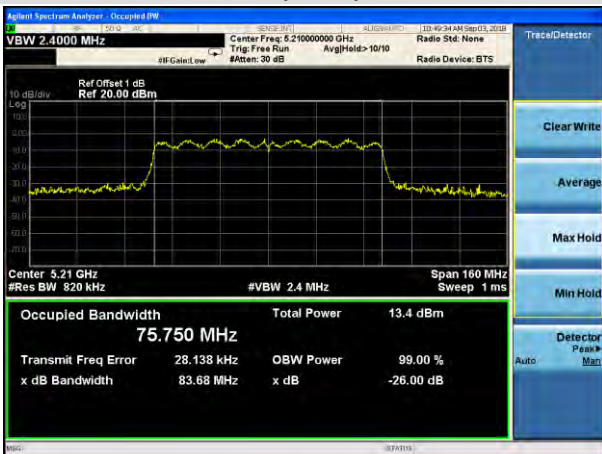

Channel 40 (5210MHz)

ANT1: Band 4 (5725 - 5850 MHz)

802.11a mode

802.11n(HT20) mode



Channel 149 (5745MHz)



Channel 149 (5745MHz)



Channel 157 (5785MHz)



Channel 157 (5785MHz)

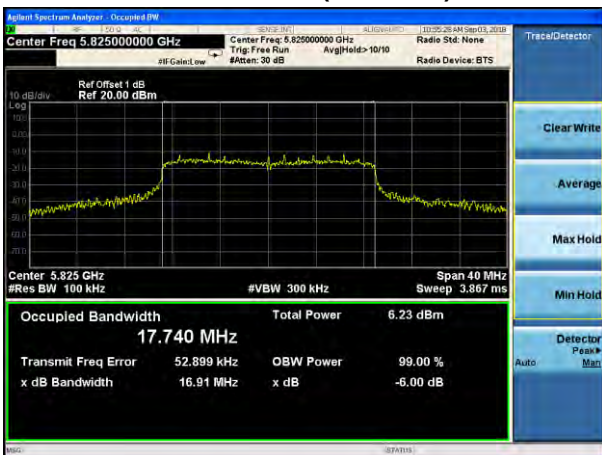

Channel 165 (5825MHz)



Channel 165 (5825MHz)

802.11ac(HT20) mode



Channel 149 (5745MHz)



Channel 157 (5785MHz)



Channel 165 (5825MHz)

802.11n(HT40) mode

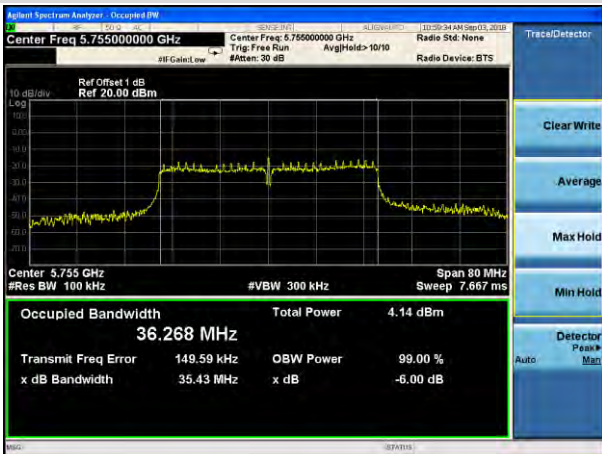

Channel 151 (5755MHz)

802.11ac(HT40) mode

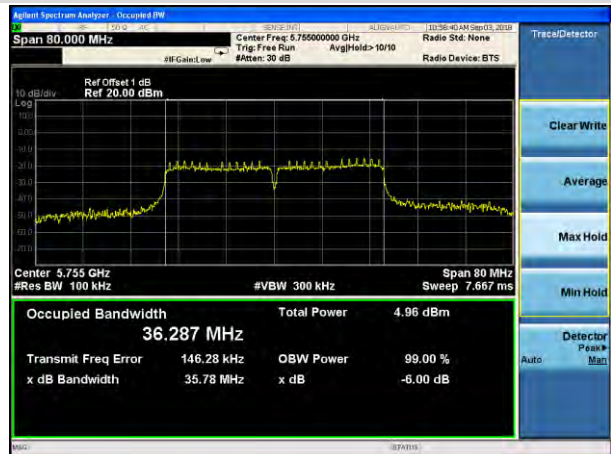

Channel 151 (5755MHz)

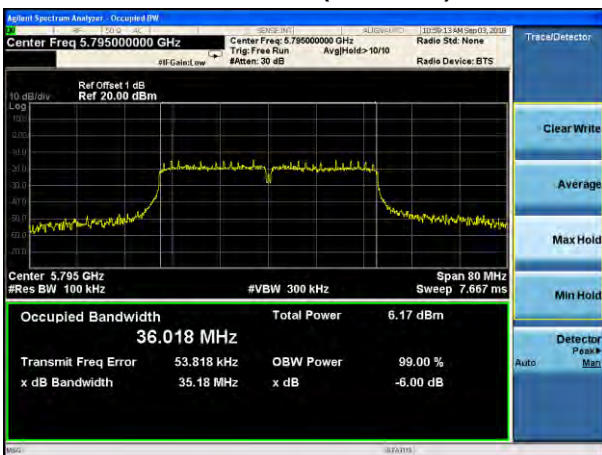

Channel 159 (5795MHz)

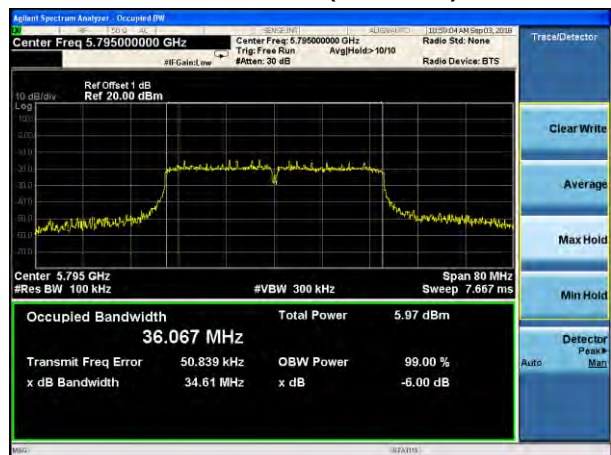

Channel 159 (5795MHz)

802.11ac(HT80) mode

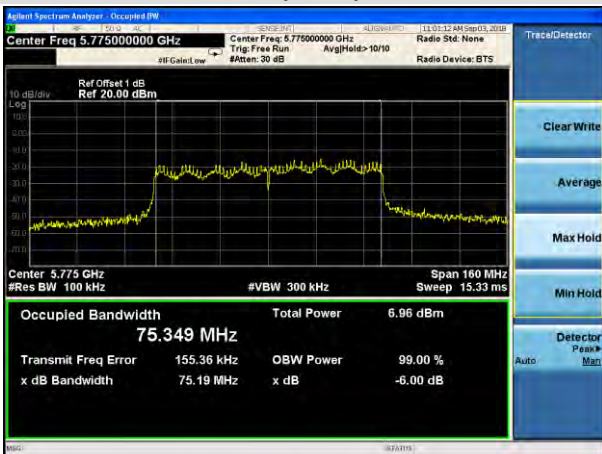

Channel 155(5775MHz)

Note: Only record the worst case data of ANT 1.

4.3 Peak Transmit Power

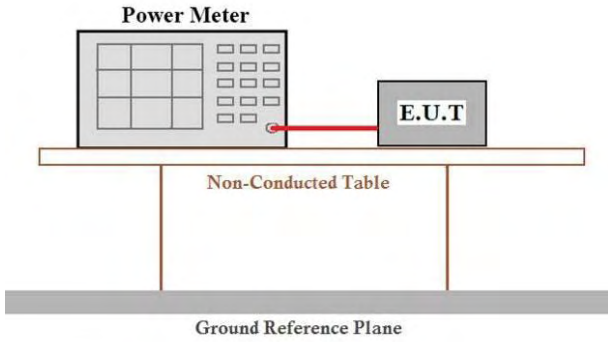
Test Requirement:	FCC Part15 E Section 15.407
Test Method:	KDB 789033 D02 General UNII Test Procedures New Rules v02r01
Limit:	For the band 5.15-5.25GHz, 5.25-5.35GHz, 5.47-5.725GHz, the maximum conducted output power over the frequency bands of operation shall not exceed 250mW. For the band 5.725-5.85GHz, the maximum conducted output power over the frequency bands of operation shall not exceed 1W.
Test setup:	 <p>The diagram illustrates the test setup. A Power Meter is connected to an E.U.T. (Equipment Under Test) via a red cable. Both are placed on a Non-Conducted Table, which is supported by two legs. Below the table is a Ground Reference Plane.</p>
Test procedure:	<p>Measurement using an RF average power meter</p> <ul style="list-style-type: none"> (i) Measurements may be performed using a wideband RF power meter with a thermocouple detector or equivalent if all of the conditions listed below are satisfied <ul style="list-style-type: none"> a) The EUT is configured to transmit continuously or to transmit with a constant duty cycle. b) At all times when the EUT is transmitting, it must be transmitting at its maximum power control level. c) The integration period of the power meter exceeds the repetition period of the transmitted signal by at least a factor of five. (ii) If the transmitter does not transmit continuously, measure the duty cycle, x, of the transmitter output signal as described in section B). (iii) Measure the average power of the transmitter. This measurement is an average over both the on and off periods of the transmitter. (iv) Adjust the measurement in dBm by adding $10 \log(1/x)$ where x is the duty cycle (e.g., $10 \log(1/0.25)$ if the duty cycle is 25 percent).
Test results:	Pass

Measurement Data**Band 1 (5150-5250 MHz)**

Test Mode	Channel	Frequency (MHz)	Measured Power (dBm)		Duty Factor (dB)	Sum Power (dBm)	Max. Limit (dBm)	Result
			ANT1	ANT2				
802.11a	36	5180.00	2.37	2.76	0.42	/	23.34	Pass
	40	5200.00	2.14	2.06	0.42	/	23.34	Pass
	48	5240.00	2.05	2.47	0.42	/	23.34	Pass
802.11n (HT20)	36	5180.00	2.09	2.51	0.42	5.02	23.34	Pass
	40	5200.00	2.01	2.53	0.42	4.96	23.34	Pass
	48	5240.00	2.04	2.15	0.42	4.61	23.34	Pass
802.11ac (HT20)	36	5180.00	1.99	2.22	0.66	4.87	23.34	Pass
	40	5200.00	2.20	2.14	0.66	5.00	23.34	Pass
	48	5240.00	1.78	2.32	0.66	4.76	23.34	Pass
802.11n (HT40)	38	5190.00	1.57	2.50	0.84	4.91	23.34	Pass
	46	5230.00	1.53	2.34	0.84	4.71	23.34	Pass
802.11 ac (HT40)	38	5190.00	1.46	2.60	0.87	4.93	23.34	Pass
	46	5230.00	1.55	2.53	0.87	4.95	23.34	Pass
802.11ac (HT80)	42	5210.00	1.21	1.71	1.32	4.24	23.34	Pass

Note:

1, As Directional gain = $10 \log[(10^{G1/20} + 10G^{2/20})^2 / N_{ANT}]$ dBi=6.64>6dBi, so limit=23.98-(6.64-6.00)=23.34dBm.

2, Sum Power = Measured Power + Duty Factor

3, Duty Factor = $10 \log (1/\text{Duty Cycle})$

Band 4 (5725 - 5850)

Test Mode	Channel	Frequency (MHz)	Measured Power (dBm)		Duty Factor (dB)	Sum Power (dBm)	Max. Limit (dBm)	Result
			ANT1	ANT2				
802.11a	149	5745.00	2.46	2.85	0.42	/	29.36	Pass
	157	5785.00	2.18	2.1	0.42	/	29.36	Pass
	165	5825.00	2.12	2.54	0.42	/	29.36	Pass
802.11n (HT20)	149	5745.00	2.01	2.56	0.42	4.99	29.36	Pass
	157	5785.00	2.03	2.41	0.42	4.86	29.36	Pass
	165	5825.00	2.03	2.14	0.42	4.59	29.36	Pass
802.11ac (HT20)	149	5745.00	2.05	2.28	0.66	4.99	29.36	Pass
	157	5785.00	1.98	2.23	0.66	4.87	29.36	Pass
	165	5825.00	1.79	2.33	0.66	4.78	29.36	Pass
802.11n (HT40)	151	5755.00	1.58	2.51	0.84	4.93	29.36	Pass
	159	5795.00	1.5	2.31	0.84	4.65	29.36	Pass
802.11 ac (HT40)	151	5755.00	1.49	2.63	0.87	4.99	29.36	Pass
	159	5795.00	1.57	2.55	0.87	4.99	29.36	Pass
802.11ac (HT80)	155	5775.00	1.23	1.73	1.32	4.28	29.36	Pass

Note:

1, As Directional gain = $10 \log[(10^{G1/20} + 10^{G2/20})^2 / N_{ANT}]$ dBi=6.64>6dBi, so limit=30-(6.64-6.00)=29.36dBm.

2, Sum Power = Measured Power + Duty Factor

3, Duty Factor = $10 \log (1/\text{Duty Cycle})$

Duty Cycle:

802.11a

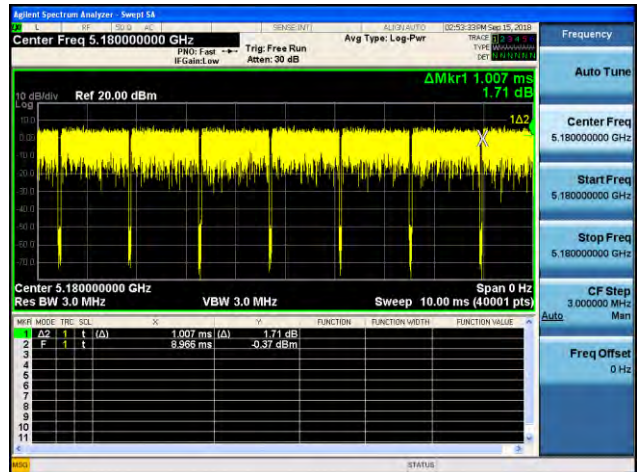
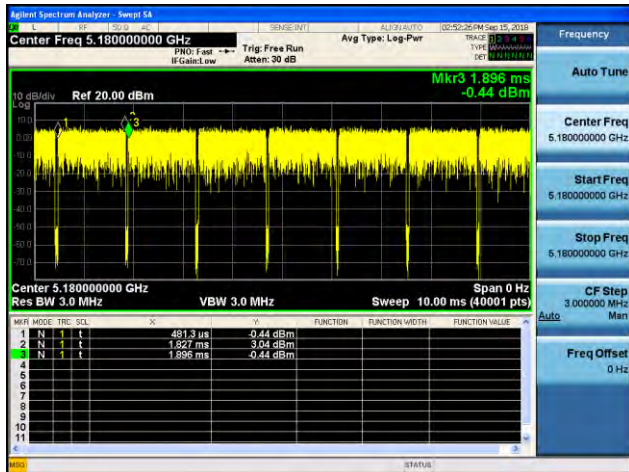

$$\text{Duty Cycle} = T_{ON}/T = ((T_{\text{mark}2} - T_{\text{mark}1}) * \text{NUM} + T_{\Delta}) / 10\text{ms} = ((1.827 - 0.481) * 6 + 1.007) / 10\text{ms} = 0.91$$

$$\text{Duty Factor} = 10 \log (1/\text{Duty Cycle}) = 10\log(1/0.91) = 0.42$$

802.11n20

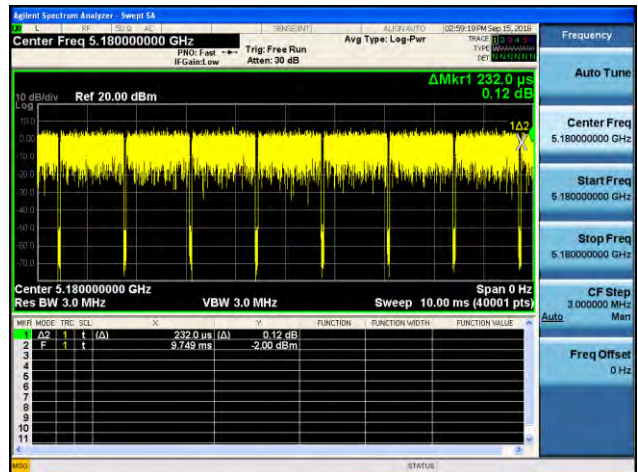
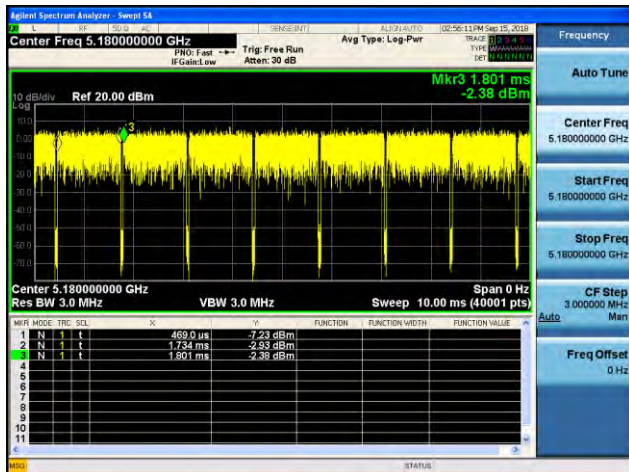

$$\text{Duty Cycle} = T_{ON}/T = ((T_{\text{mark}2} - T_{\text{mark}1}) * \text{NUM} + T_{\Delta}) / 10\text{ms} = ((1.734 - 0.469) * 7 + 0.232) / 10\text{ms} = 0.91$$

$$\text{Duty Factor} = 10 \log (1/\text{Duty Cycle}) = 10\log(1/0.91) = 0.42$$

802.11ac20

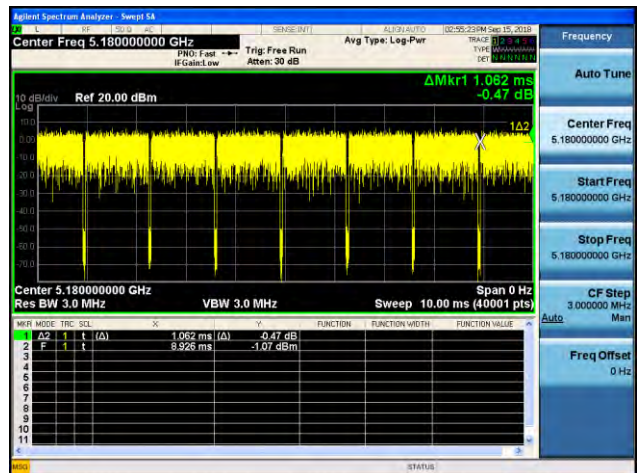
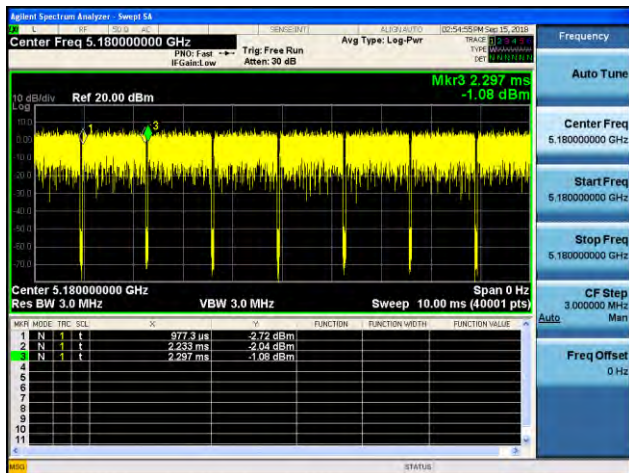

$$\text{Duty Cycle} = T_{ON}/T = ((T_{\text{mark}2} - T_{\text{mark}1}) * \text{NUM} + T_{\Delta}) / 10\text{ms} = ((2.233 - 0.977) * 6 + 1.062) / 10\text{ms} = 0.86$$

$$\text{Duty Factor} = 10 \log (1/\text{Duty Cycle}) = 10\log(1/0.86) = 0.66$$

802.11n40

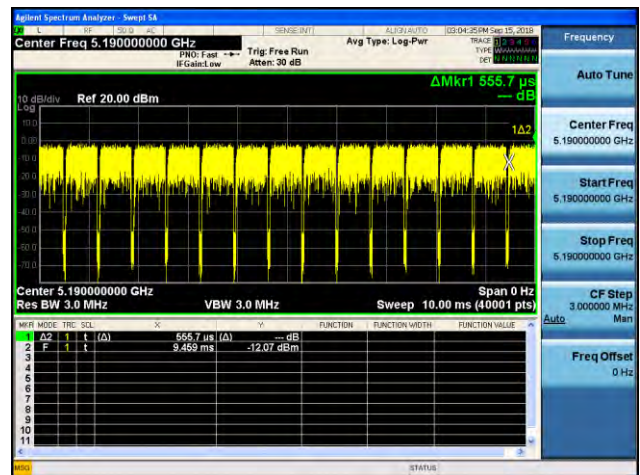
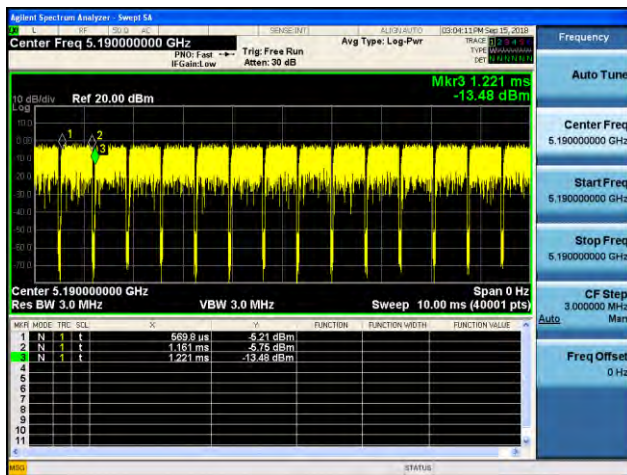

$$\text{Duty Cycle} = T_{ON}/T = ((T_{\text{mark}2} - T_{\text{mark}1}) * \text{NUM} + T_{\Delta}) / 10\text{ms} = ((1.161 - 0.570) * 13 + 0.556) / 10\text{ms} = 0.82$$

$$\text{Duty Factor} = 10 \log (1/\text{Duty Cycle}) = 10\log(1/0.82) = 0.84$$

802.11ac40

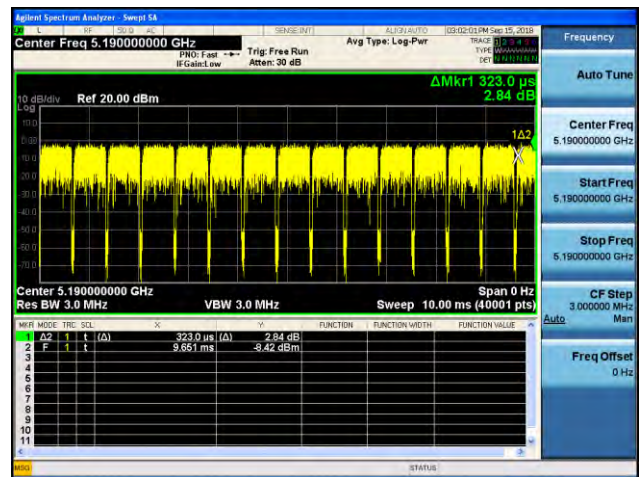
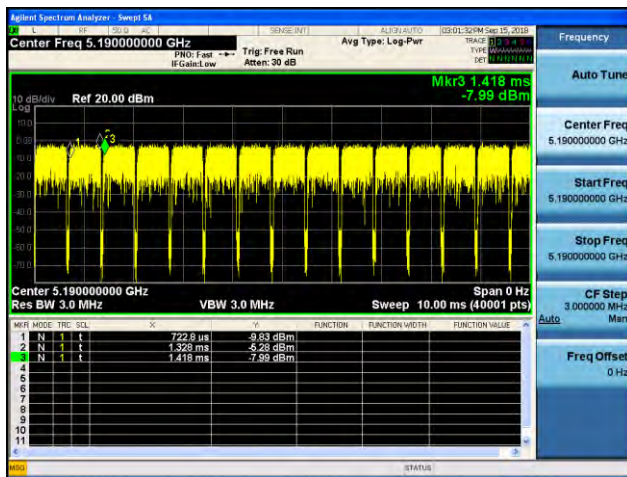

$$\text{Duty Cycle} = T_{ON}/T = ((T_{\text{mark}2} - T_{\text{mark}1}) * \text{NUM} + T_{\Delta}) / 10\text{ms} = ((1.328 - 0.723) * 13 + 0.323) / 10\text{ms} = 0.82$$

$$\text{Duty Factor} = 10 \log (1/\text{Duty Cycle}) = 10\log(1/0.82) = 0.87$$

802.11ac80



$$\text{Duty Cycle} = T_{ON}/T = ((T_{\text{mark}2} - T_{\text{mark}1}) * \text{NUM} + T_{\Delta}) / 10\text{ms} = ((0.874 - 0.596) * 26 + 0.147) / 10\text{ms} = 0.74$$

$$\text{Duty Factor} = 10 \log (1/\text{Duty Cycle}) = 10\log(1/0.73) = 1.32$$

4.4 Power Spectral Density

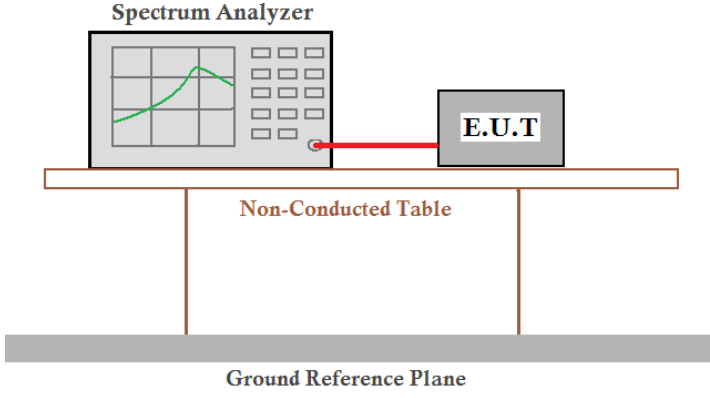
Test Requirement:	FCC Part15 E Section 15.407
Test Method:	KDB 789033 D02 General UNII Test Procedures New Rules v02r01
Limit:	$\leq 11.00\text{dBm/MHz}$ for 5150MHz-5250MHz, 5250-5350MHz and 5470-5725 MHz $\leq 30.00\text{dBm/500KHz}$ for 5725MHz-5850MHz
Test setup:	 <p>The diagram illustrates the test setup. A Spectrum Analyzer is connected to an E.U.T. (Equipment Under Test) via a red cable. Both are placed on a Non-Conducted Table, which is supported by a Ground Reference Plane.</p>
Test procedure:	<ol style="list-style-type: none"> 1) Create an average power spectrum for the EUT operating mode being tested by following the instructions in section E)2) for measuring maximum conducted output power using a spectrum analyzer or EMI receiver: select the appropriate test method (SA-1, SA-2, SA-3, or alternatives to each) and apply it up to, but not including, the step labeled, "Compute power...". 2) Use the peak search function on the instrument to find the peak of the spectrum. 3) Make the following adjustments to the peak value of the spectrum, if applicable: <ol style="list-style-type: none"> a) If Method SA-2 or SA-2 Alternative was used, add $10 \log(1/x)$, where x is the duty cycle, to the peak of the spectrum. b) If Method SA-3 Alternative was used and the linear mode was used in step E)2)g)(viii), add 1 dB to the final result to compensate for the difference between linear averaging and power averaging. 4) The result is the PSD.
Test results:	Pass

Measurement Data**Band 1 (5150-5250 MHz)**

Test Mode	Channel	Frequency (MHz)	Power Density (dBm/MHz)		Duty Factor (dB)	Sum PSD (dBm/MHz)	Max. Limit (dBm)	Result
			ANT1	ANT2				
802.11a	36	5180.00	0.988	1.434	0.04	/	10.36	Pass
	40	5200.00	1.618	2.134	0.04	/	10.36	Pass
	48	5240.00	2.996	0.892	0.04	/	10.36	Pass
802.11n (HT20)	36	5180.00	1.305	3.690	0.04	5.71	10.36	Pass
	40	5200.00	1.098	2.435	0.04	4.87	10.36	Pass
	48	5240.00	0.163	1.292	0.04	3.81	10.36	Pass
802.11ac (HT20)	36	5180.00	1.597	2.227	0.04	4.97	10.36	Pass
	40	5200.00	0.339	2.595	0.04	4.66	10.36	Pass
	48	5240.00	-0.805	1.033	0.04	3.26	10.36	Pass
802.11n (HT40)	38	5190.00	-1.997	-2.337	0.04	0.89	10.36	Pass
	46	5230.00	-1.727	-1.057	0.04	1.67	10.36	Pass
802.11 ac (HT40)	38	5190.00	-1.487	-2.116	0.04	1.26	10.36	Pass
	46	5230.00	-1.152	-2.904	0.04	1.11	10.36	Pass
802.11ac (HT80)	42	5210.00	-2.118	-3.722	0.04	0.20	10.36	Pass

Note:

1, As Directional gain = $10 \log[(10^{G1/20} + 10^{G2/20})^2 / N_{ANT}]$ dBi=6.64>6dBi,

so limit=11-(6.64-6.00)=10.36dBm/1MHz.

2, Sum PSD(dBm/MHz)= PSD(dBm/MHz)+ Duty factor.

3, Duty Factor = $10 \log (1/\text{Duty Cycle})$

Band 4 (5725 - 5850)

Test Mode	Channel	Frequency (MHz)	Power Density (dBm/500 KHz)		Duty Factor (dB)	Sum PSD (dBm/500 KHz)	Max. Limit (dBm)	Result
			ANT1	ANT2				
802.11a	149	5745.00	-4.501	-4.700	0.04	/	29.36	Pass
	157	5785.00	-1.686	-2.257	0.04	/	29.36	Pass
	165	5825.00	-3.819	-3.544	0.04	/	29.36	Pass
802.11n (HT20)	149	5745.00	-2.475	-4.833	0.04	-0.45	29.36	Pass
	157	5785.00	-0.843	-0.078	0.04	2.61	29.36	Pass
	165	5825.00	-2.922	-3.754	0.04	-0.27	29.36	Pass
802.11ac (HT20)	149	5745.00	-5.744	-5.118	0.04	-2.37	29.36	Pass
	157	5785.00	-2.136	-2.401	0.04	0.78	29.36	Pass
	165	5825.00	-3.723	-1.482	0.04	0.59	29.36	Pass
802.11n (HT40)	151	5755.00	-8.338	-6.009	0.04	-3.97	29.36	Pass
	159	5795.00	-5.666	-5.644	0.04	-2.60	29.36	Pass
802.11 ac (HT40)	151	5755.00	-8.716	-5.762	0.04	-3.94	29.36	Pass
	159	5795.00	-7.233	-5.254	0.04	-3.08	29.36	Pass
802.11ac (HT80)	155	5775.00	-8.160	-9.885	0.04	-5.89	29.36	Pass

Note:

1, As Directional gain = $10 \log[(10^{G1/20} + 10^{G2/20})^2 / N_{ANT}]$ dBi=6.64>6dBi,

so limit=30-(6.64-6.00)=29.36dBm/1MHz.

2, Sum PSD(dBm/500kHz)= PSD(dBm/KHz)+ Duty factor.

3, Duty Factor = $10 \log (1/\text{Duty Cycle})$

Test plots as followed:

ANT1: Band 1 (5150 - 5250 MHz)

802.11a mode

802.11n(HT20) mode

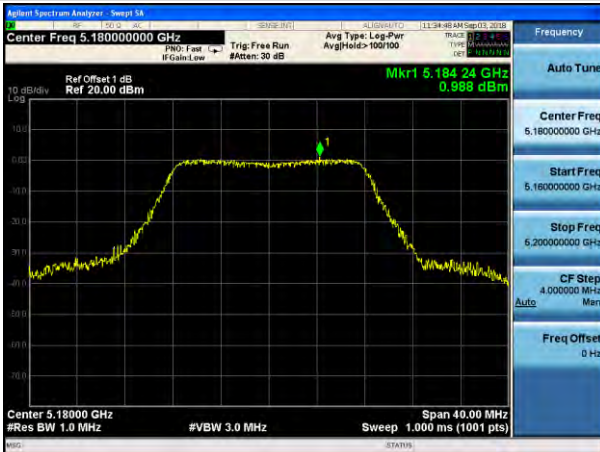

Channel 36 (5180MHz)

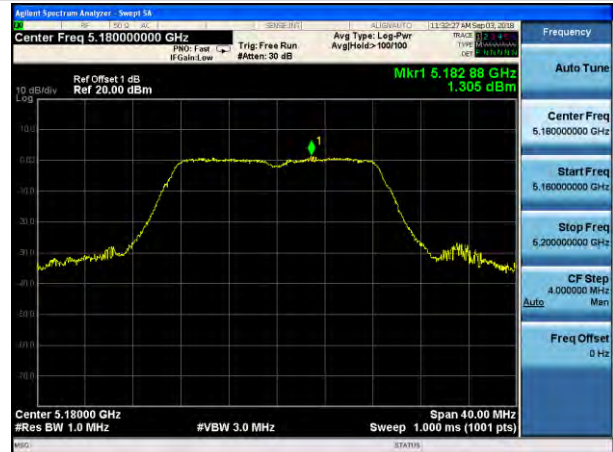

Channel 36 (5180MHz)

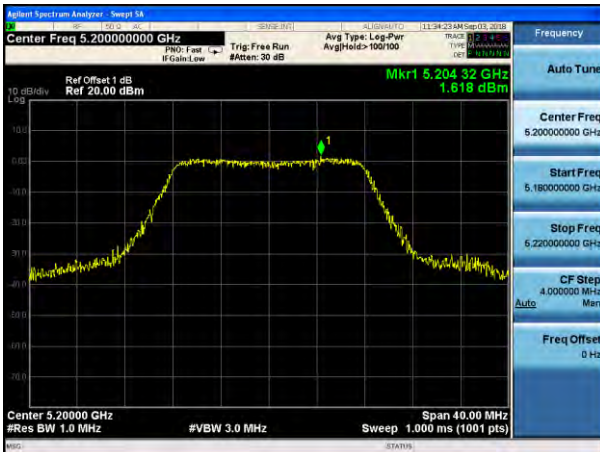

Channel 40 (5200MHz)

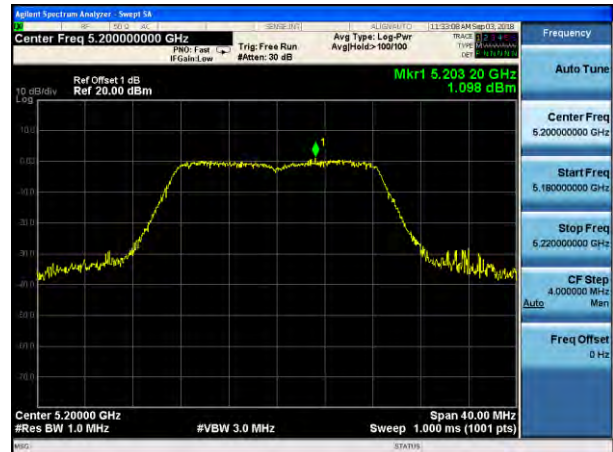

Channel 40 (5200MHz)



Channel 48 (5240MHz)

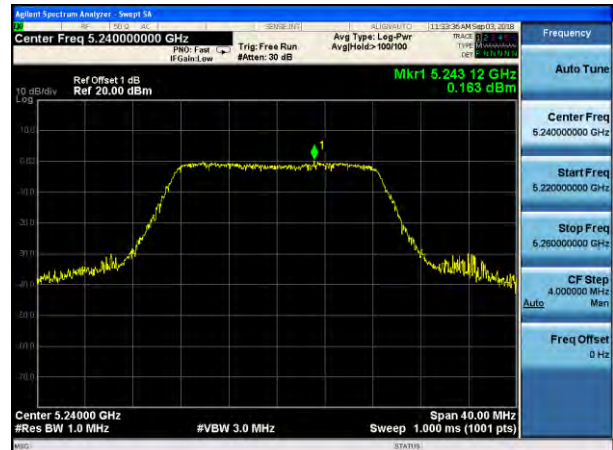

Channel 48 (5240MHz)

802.11ac(HT20) mode



Channel 36 (5180MHz)

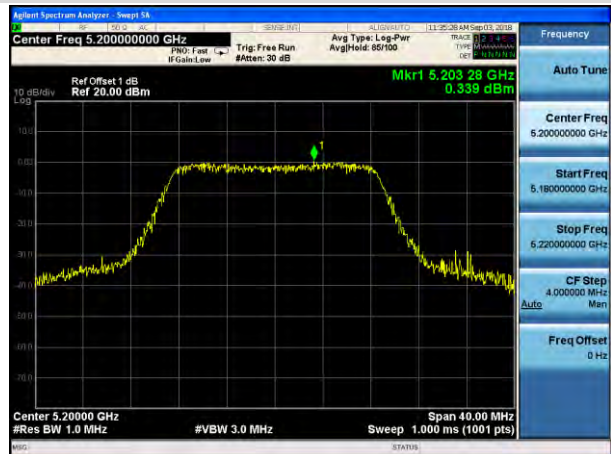

Channel 40 (5200MHz)

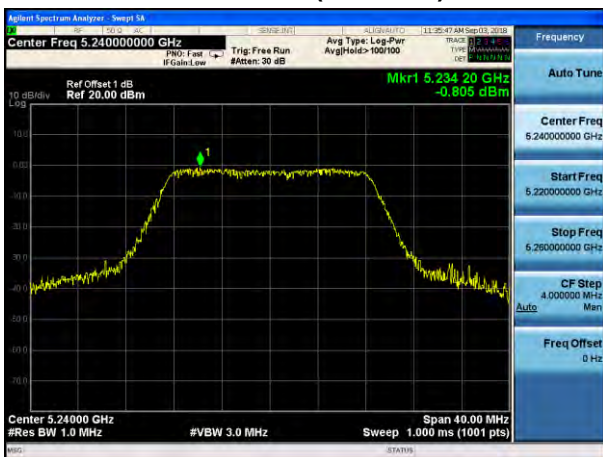

Channel 48 (5240MHz)

802.11n(HT40) mode

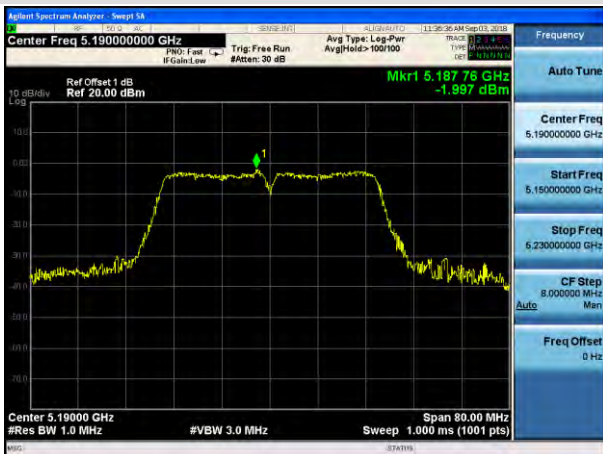

Channel 38 (5190MHz)



Channel 46 (5230MHz)

802.11ac(HT40) mode

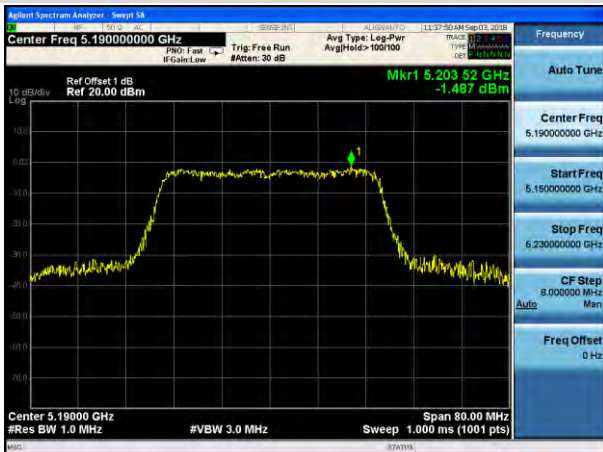

Channel 38 (5190MHz)

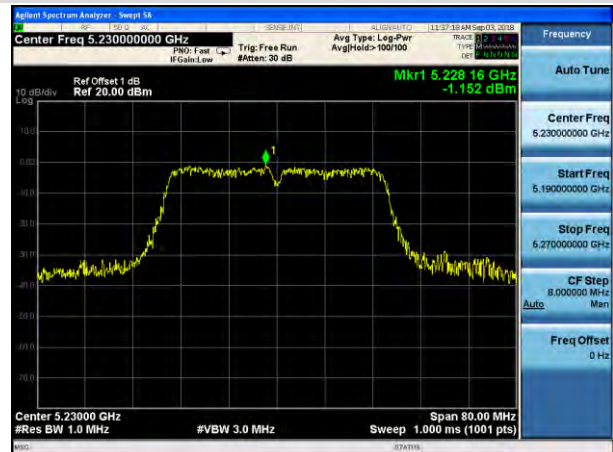

Channel 46 (5230MHz)

802.11ac(HT80) mode

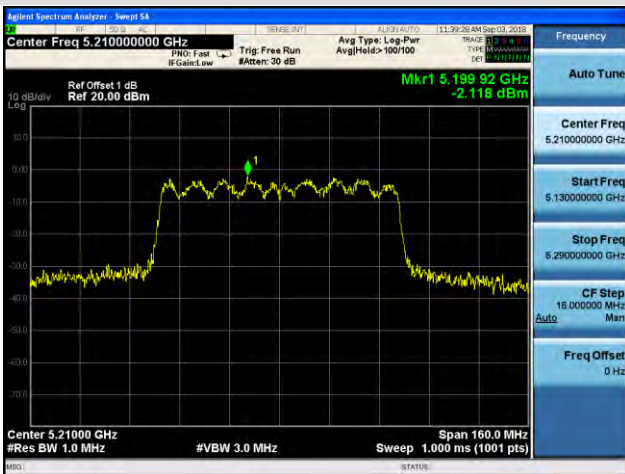

Channel 40 (5210MHz)

ANT1: Band 4 (5725 - 5850 MHz)

802.11a mode

802.11n(HT20) mode



Channel 149 (5745MHz)



Channel 149 (5745MHz)

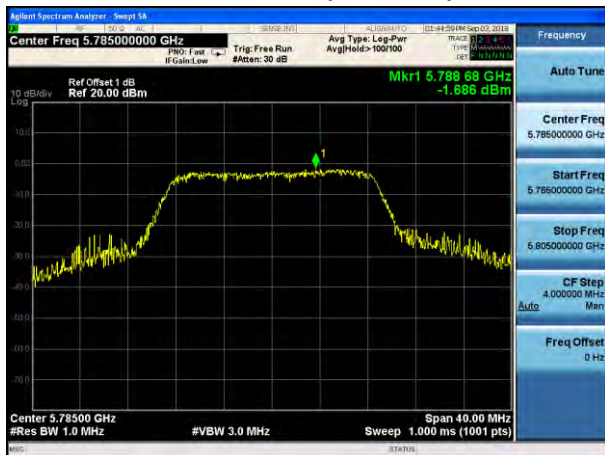

Channel 157 (5785MHz)

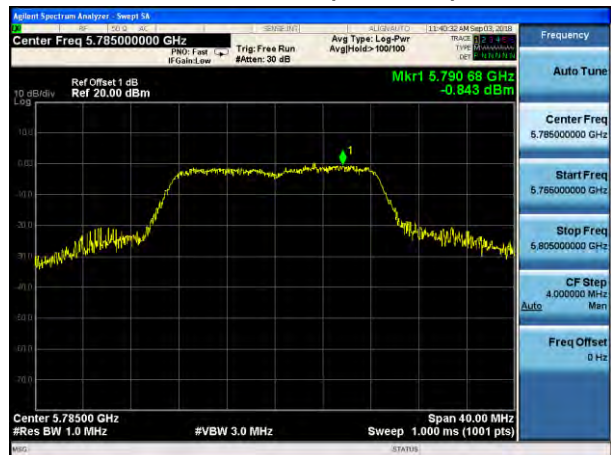

Channel 157 (5785MHz)



Channel 165 (5825MHz)

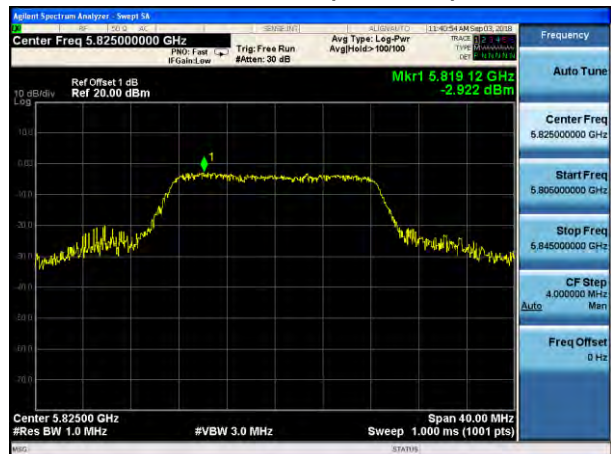

Channel 165 (5825MHz)

802.11ac(HT20) mode

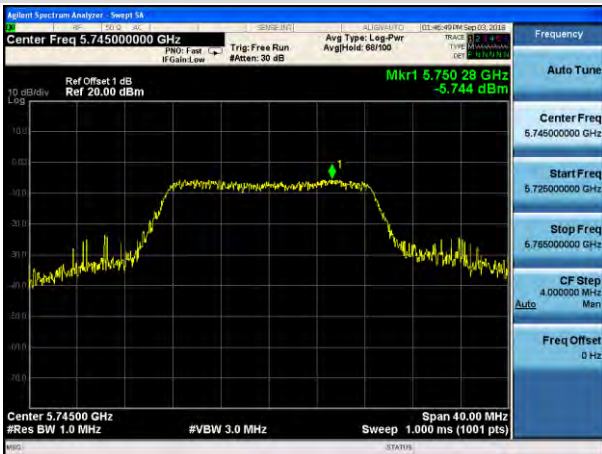

Channel 149 (5745MHz)

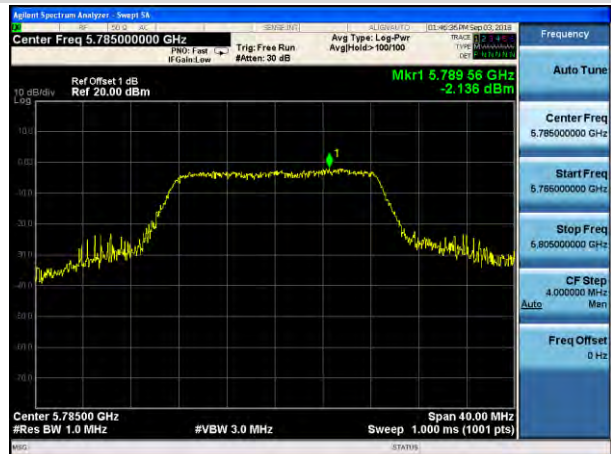

Channel 157 (5785MHz)

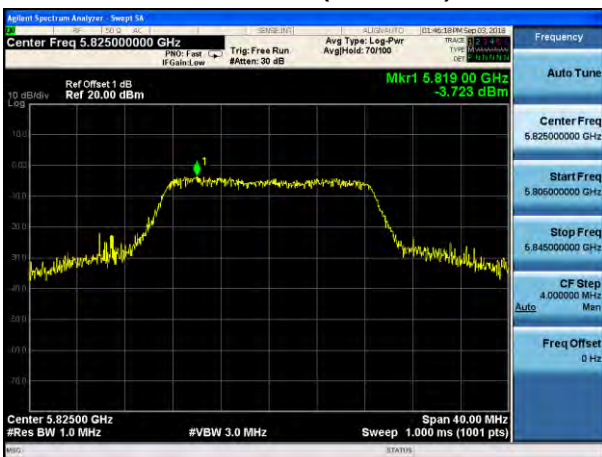

Channel 165 (5825MHz)

802.11n(HT40) mode



Channel 151 (5755MHz)

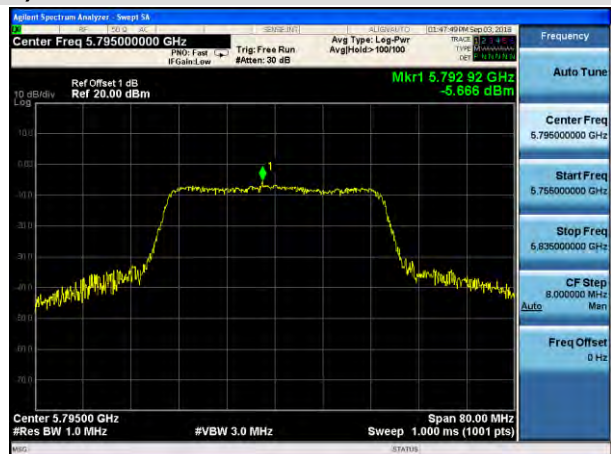

Channel 159 (5795MHz)

802.11ac(HT40) mode



Channel 151 (5755MHz)



Channel 159 (5795MHz)

802.11ac(HT80) mode



Channel 155(5775MHz)

ANT2: Band 1 (5150 - 5250 MHz)

802.11a mode



Channel 36 (5180MHz)

802.11n(HT20) mode



Channel 36 (5180MHz)



Channel 40 (5200MHz)



Channel 40 (5200MHz)



Channel 48 (5240MHz)



Channel 48 (5240MHz)

802.11ac(HT20) mode



Channel 36 (5180MHz)



Channel 40 (5200MHz)



Channel 48 (5240MHz)

802.11n(HT40) mode



Channel 38 (5190MHz)



Channel 46 (5230MHz)

802.11ac(HT40) mode



Channel 38 (5190MHz)



Channel 46 (5230MHz)

802.11ac(HT80) mode



Channel 40 (5210MHz)

ANT2: Band 4 (5725 - 5850 MHz)

802.11a mode

802.11n(HT20) mode



Channel 149 (5745MHz)



Channel 149 (5745MHz)



Channel 157 (5785MHz)

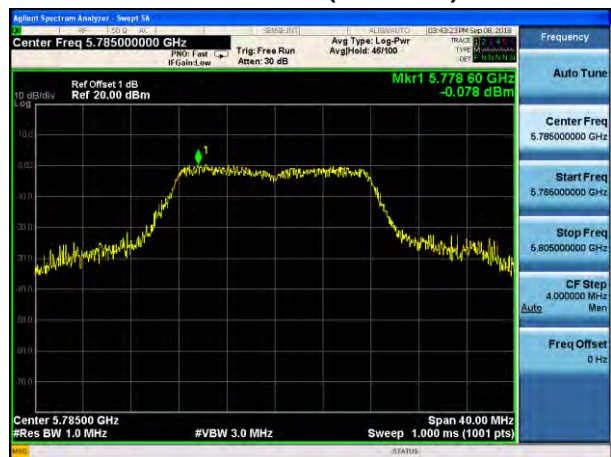

Channel 157 (5785MHz)



Channel 165 (5825MHz)



Channel 165 (5825MHz)

802.11ac(HT20) mode



Channel 149 (5745MHz)



Channel 165 (5825MHz)



Channel 157 (5785MHz)

802.11n(HT40) mode



Channel 151 (5755MHz)



Channel 159 (5795MHz)

802.11ac(HT40) mode

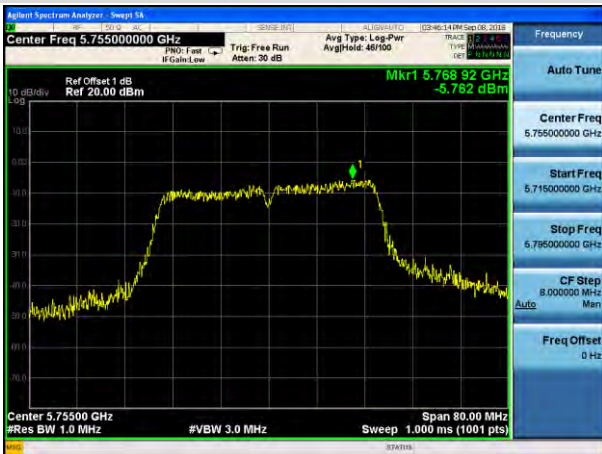

Channel 151 (5755MHz)



Channel 159 (5795MHz)

802.11ac(HT80) mode

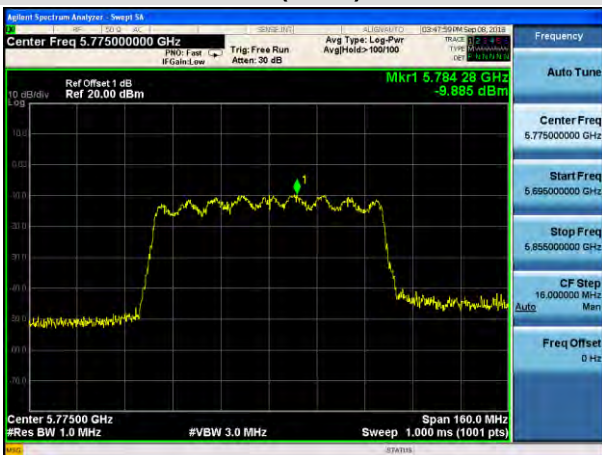

Channel 155(5775MHz)

4.5 Band Edge

Test Requirement:	FCC Part15 E Section 15.407 and 15.205																							
Test Method:	ANSI C63.10:2013																							
Test site:	Measurement Distance: 3m (Semi-Anechoic Chamber)																							
Receiver setup:	<table border="1"> <thead> <tr> <th>Frequency</th> <th>Detector</th> <th>RBW</th> <th>VBW</th> <th>Remark</th> </tr> </thead> <tbody> <tr> <td>30MHz-1GHz</td> <td>Quasi-peak</td> <td>100KHz</td> <td>300KHz</td> <td>Quasi-peak Value</td> </tr> <tr> <td rowspan="2">Above 1GHz</td> <td>Peak</td> <td>1MHz</td> <td>3MHz</td> <td>Peak Value</td> </tr> <tr> <td>AV</td> <td>1MHz</td> <td>3MHz</td> <td>Average Value</td> </tr> </tbody> </table>				Frequency	Detector	RBW	VBW	Remark	30MHz-1GHz	Quasi-peak	100KHz	300KHz	Quasi-peak Value	Above 1GHz	Peak	1MHz	3MHz	Peak Value	AV	1MHz	3MHz	Average Value	
Frequency	Detector	RBW	VBW	Remark																				
30MHz-1GHz	Quasi-peak	100KHz	300KHz	Quasi-peak Value																				
Above 1GHz	Peak	1MHz	3MHz	Peak Value																				
	AV	1MHz	3MHz	Average Value																				
Limit:	<table border="1"> <thead> <tr> <th>Frequency</th> <th>Limit (dBuV/m @3m)</th> <th>Remark</th> </tr> </thead> <tbody> <tr> <td>30MHz-88MHz</td> <td>40.0</td> <td>Quasi-peak Value</td> </tr> <tr> <td>88MHz-216MHz</td> <td>43.5</td> <td>Quasi-peak Value</td> </tr> <tr> <td>216MHz-960MHz</td> <td>46.0</td> <td>Quasi-peak Value</td> </tr> <tr> <td>960MHz-1GHz</td> <td>54.0</td> <td>Quasi-peak Value</td> </tr> <tr> <td rowspan="2">Above 1GHz</td> <td>54.0</td> <td>Average Value</td> </tr> <tr> <td>68.2</td> <td>Peak Value</td> </tr> </tbody> </table> <p>Undesirable emission limits:</p> <p>(1) For transmitters operating in the 5.15-5.25 GHz band: all emissions outside of the 5.15-5.35 GHz band shall not exceed an EIRP of -27 dBm/MHz.</p> <p>(2) For transmitters operating in the 5.25-5.35 GHz band: all emissions outside of the 5.15-5.35 GHz band shall not exceed an EIRP of -27 dBm/MHz. Devices operating in the 5.25-5.35 GHz band that generate emissions in the 5.15-5.25 GHz band must meet all applicable technical requirements for operation in the 5.15-5.25 GHz band (including indoor use) or alternatively meet an out-of-band emission EIRP limit of -27 dBm/MHz in the 5.15-5.25 GHz band.</p> <p>(3) For transmitters operating in the 5.47-5.725 GHz band: all emissions outside of the 5.47-5.725 GHz band shall not exceed an EIRP of -27 dBm/MHz.</p>				Frequency	Limit (dBuV/m @3m)	Remark	30MHz-88MHz	40.0	Quasi-peak Value	88MHz-216MHz	43.5	Quasi-peak Value	216MHz-960MHz	46.0	Quasi-peak Value	960MHz-1GHz	54.0	Quasi-peak Value	Above 1GHz	54.0	Average Value	68.2	Peak Value
Frequency	Limit (dBuV/m @3m)	Remark																						
30MHz-88MHz	40.0	Quasi-peak Value																						
88MHz-216MHz	43.5	Quasi-peak Value																						
216MHz-960MHz	46.0	Quasi-peak Value																						
960MHz-1GHz	54.0	Quasi-peak Value																						
Above 1GHz	54.0	Average Value																						
	68.2	Peak Value																						
Test Procedure:	<p>a. The EUT was placed on the top of a rotating table 1.5 m above the ground at a 3 meter camber. The table was rotated 360 degrees to determine the position of the highest radiation.</p> <p>b. The EUT was set 3 meters away from the interference-receiving antenna, which was mounted on the top of a variable-height antenna tower.</p> <p>c. The antenna height is varied from one meter to four meters above the ground to determine the maximum value of the field strength. Both horizontal and vertical polarizations of the antenna are set to make the measurement.</p> <p>d. For each suspected emission, the EUT was arranged to its worst case and then the antenna was tuned to heights from 1 meter to 4 meters and the rotatable table was turned from 0 degrees to 360 degrees to find the maximum reading.</p> <p>e. The test-receiver system was set to Peak Detect Function and Specified Bandwidth with Maximum Hold Mode.</p> <p>f. If the emission level of the EUT in peak mode was 10dB lower than the limit specified, then testing could be stopped and the peak values of the EUT would be reported. Otherwise the emissions that did not have 10dB margin would be re-tested one by one using peak, quasi-peak or average method as specified and then reported in a data sheet.</p>																							
Test setup:	Above 1GHz																							

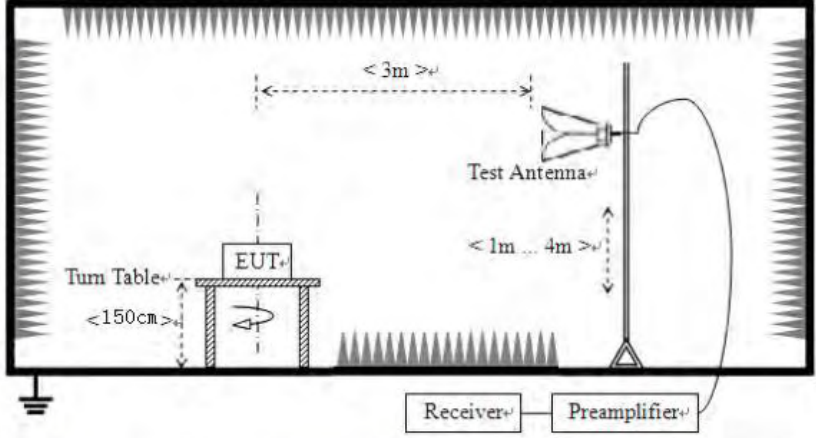
	
Test results:	Pass <i>Note: Only record the worst case data of ANT 1+ANT2.</i>

Remark:

According to KDB 789033 D02 v02r01 section G) 1) (d), for For measurements above 1000 MHz @ 3m distance, the limit of field strength is computed as follows:

$$E[\text{dBuV/m}] = \text{EIRP}[\text{dBm}] + 95.2;$$

For example, if $\text{EIRP} = -27\text{dBm}$

$$E[\text{dBuV/m}] = -27 + 95.2 = 68.2\text{dBuV/m}.$$

Measurement Data:**Band1**

Mode:		802.11a		Frequency:		5180MHz	
Antenna Pol.	Frequency (MHz)	Reading Level (dBuV)	Factor (dB/m)	Measure Level (dBuV/m)	Limit (dBuV/m)	Over limit(dB)	Detector
H	5150.00	34.14	17.18	51.32	68.20	-16.88	PK
V	5150.00	34.51	17.18	51.69	68.20	-16.51	PK
Mode:		802.11a		Frequency:		5180MHz	
Antenna Pol.	Frequency (MHz)	Reading Level (dBuV)	Factor (dB/m)	Measure Level (dBuV/m)	Limit (dBuV/m)	Over limit(dB)	Detector
H	5150.00	25.11	17.18	42.29	54.00	-11.71	AV
V	5150.00	27.68	17.18	44.86	54.00	-9.14	AV
Mode:		802.11a		Frequency:		5240MHz	
Antenna Pol.	Frequency (MHz)	Reading Level (dBuV)	Factor (dB/m)	Measure Level (dBuV/m)	Limit (dBuV/m)	Over limit(dB)	Detector
H	5350.00	33.48	17.18	50.66	68.20	-17.54	PK
V	5350.00	34.72	17.18	51.90	68.20	-16.30	PK
Mode:		802.11a		Frequency:		5240MHz	
Antenna Pol.	Frequency (MHz)	Reading Level (dBuV)	Factor (dB/m)	Measure Level (dBuV/m)	Limit (dBuV/m)	Over limit(dB)	Detector
H	5350.00	24.96	17.18	42.14	54.00	-11.86	AV
V	5350.00	27.79	17.18	44.97	54.00	-9.03	AV

Mode:		802.11n(HT20)		Frequency:		5180MHz	
Antenna Pol.	Frequency (MHz)	Reading Level (dBuV)	Factor (dB/m)	Measure Level (dBuV/m)	Limit (dBuV/m)	Over limit(dB)	Detector
H	5150.00	33.72	17.18	50.90	68.20	-17.30	PK
V	5150.00	34.85	17.18	52.03	68.20	-16.17	PK
Mode:		802.11n(HT20)		Frequency:		5180MHz	
Antenna Pol.	Frequency (MHz)	Reading Level (dBuV)	Factor (dB/m)	Measure Level (dBuV/m)	Limit (dBuV/m)	Over limit(dB)	Detector
H	5150.00	24.86	17.18	42.04	54.00	-11.96	AV
V	5150.00	27.39	17.18	44.57	54.00	-9.43	AV
Mode:		802.11n(HT20)		Frequency:		5240MHz	
Antenna Pol.	Frequency (MHz)	Reading Level (dBuV)	Factor (dB/m)	Measure Level (dBuV/m)	Limit (dBuV/m)	Over limit(dB)	Detector
H	5350.00	36.57	17.18	53.75	68.20	-14.45	PK
V	5350.00	36.91	17.18	54.09	68.20	-14.11	PK
Mode:		802.11n(HT20)		Frequency:		5240MHz	
Antenna Pol.	Frequency (MHz)	Reading Level (dBuV)	Factor (dB/m)	Measure Level (dBuV/m)	Limit (dBuV/m)	Over limit(dB)	Detector
H	5350.00	26.36	17.18	43.54	54.00	-10.46	AV
V	5350.00	30.53	17.18	47.71	54.00	-6.29	AV

Mode:		802.11ac(HT20)		Frequency:		5180MHz	
Antenna Pol.	Frequency (MHz)	Reading Level (dBuV)	Factor (dB/m)	Measure Level (dBuV/m)	Limit (dBuV/m)	Over limit(dB)	Detector
H	5150.00	36.53	17.18	53.71	68.20	-14.49	PK
V	5150.00	36.59	17.18	53.77	68.20	-14.43	PK
Mode:		802.11ac(HT20)		Frequency:		5180MHz	
Antenna Pol.	Frequency (MHz)	Reading Level (dBuV)	Factor (dB/m)	Measure Level (dBuV/m)	Limit (dBuV/m)	Over limit(dB)	Detector
H	5150.00	26.53	17.18	43.71	54.00	-10.29	AV
V	5150.00	30.19	17.18	47.37	54.00	-6.63	AV
Mode:		802.11ac(HT20)		Frequency:		5240MHz	
Antenna Pol.	Frequency (MHz)	Reading Level (dBuV)	Factor (dB/m)	Measure Level (dBuV/m)	Limit (dBuV/m)	Over limit(dB)	Detector
H	5350.00	36.00	17.18	53.18	68.20	-15.02	PK
V	5350.00	36.77	17.18	53.95	68.20	-14.25	PK
Mode:		802.11ac(HT20)		Frequency:		5240MHz	
Antenna Pol.	Frequency (MHz)	Reading Level (dBuV)	Factor (dB/m)	Measure Level (dBuV/m)	Limit (dBuV/m)	Over limit(dB)	Detector
H	5350.00	23.34	17.18	40.52	54.00	-13.48	AV
V	5350.00	27.12	17.18	44.30	54.00	-9.70	AV

Mode:		802.11n(HT40)		Frequency:		5190MHz	
Antenna Pol.	Frequency (MHz)	Reading Level (dBuV)	Factor (dB/m)	Measure Level (dBuV/m)	Limit (dBuV/m)	Over limit(dB)	Detector
H	5150.00	33.16	17.20	50.36	68.20	-17.84	PK
V	5150.00	35.58	17.20	52.78	68.20	-15.42	PK
Mode:		802.11n(HT40)		Frequency:		5190MHz	
Antenna Pol.	Frequency (MHz)	Reading Level (dBuV)	Factor (dB/m)	Measure Level (dBuV/m)	Limit (dBuV/m)	Over limit(dB)	Detector
H	5150.00	23.25	17.20	40.45	54.00	-13.55	AV
V	5150.00	28.92	17.20	46.12	54.00	-7.88	AV
Mode:		802.11n(HT40)		Frequency:		5230MHz	
Antenna Pol.	Frequency (MHz)	Reading Level (dBuV)	Factor (dB/m)	Measure Level (dBuV/m)	Limit (dBuV/m)	Over limit(dB)	Detector
H	5350.00	33.44	17.20	50.64	68.20	-17.56	PK
V	5350.00	34.05	17.20	51.25	68.20	-16.95	PK
Mode:		802.11n(HT40)		Frequency:		5230MHz	
Antenna Pol.	Frequency (MHz)	Reading Level (dBuV)	Factor (dB/m)	Measure Level (dBuV/m)	Limit (dBuV/m)	Over limit(dB)	Detector
H	5350.00	23.04	17.20	40.24	54.00	-13.76	AV
V	5350.00	29.17	17.20	46.37	54.00	-7.63	AV

Mode:		802.11ac(HT40)		Frequency:		5190MHz	
Antenna Pol.	Frequency (MHz)	Reading Level (dBuV)	Factor (dB/m)	Measure Level (dBuV/m)	Limit (dBuV/m)	Over limit(dB)	Detector
H	5150.00	34.14	17.20	51.34	68.20	-16.86	PK
V	5150.00	31.60	17.20	48.80	68.20	-19.40	PK
Mode:		802.11ac(HT40)		Frequency:		5190MHz	
Antenna Pol.	Frequency (MHz)	Reading Level (dBuV)	Factor (dB/m)	Measure Level (dBuV/m)	Limit (dBuV/m)	Over limit(dB)	Detector
H	5150.00	23.16	17.20	40.36	54.00	-13.64	AV
V	5150.00	28.85	17.20	46.05	54.00	-7.95	AV
Mode:		802.11ac(HT40)		Frequency:		5230MHz	
Antenna Pol.	Frequency (MHz)	Reading Level (dBuV)	Factor (dB/m)	Measure Level (dBuV/m)	Limit (dBuV/m)	Over limit(dB)	Detector
H	5350.00	33.69	17.20	50.89	68.20	-17.31	PK
V	5350.00	31.78	17.20	48.98	68.20	-19.22	PK
Mode:		802.11ac(HT40)		Frequency:		5230MHz	
Antenna Pol.	Frequency (MHz)	Reading Level (dBuV)	Factor (dB/m)	Measure Level (dBuV/m)	Limit (dBuV/m)	Over limit(dB)	Detector
H	5350.00	23.33	17.20	40.53	54.00	-13.47	AV
V	5350.00	29.15	17.20	46.35	54.00	-7.65	AV

Mode:		802.11ac(HT80)		Frequency:		5210MHz	
Antenna Pol.	Frequency (MHz)	Reading Level (dBuV)	Factor (dB/m)	Measure Level (dBuV/m)	Limit (dBuV/m)	Over limit(dB)	Detector
H	5150.00	35.28	17.20	52.48	68.20	-15.72	PK
V	5150.00	32.43	17.20	49.63	68.20	-18.57	PK
Mode:		802.11ac(HT80)		Frequency:		5210MHz	
Antenna Pol.	Frequency (MHz)	Reading Level (dBuV)	Factor (dB/m)	Measure Level (dBuV/m)	Limit (dBuV/m)	Over limit(dB)	Detector
H	5150.00	24.91	17.20	42.11	54.00	-11.89	AV
V	5150.00	28.82	17.20	46.02	54.00	-7.98	AV
Mode:		802.11ac(HT80)		Frequency:		5210MHz	
Antenna Pol.	Frequency (MHz)	Reading Level (dBuV)	Factor (dB/m)	Measure Level (dBuV/m)	Limit (dBuV/m)	Over limit(dB)	Detector
H	5350.00	34.23	17.20	51.43	68.20	-16.77	PK
V	5350.00	33.24	17.20	50.44	68.20	-17.76	PK
Mode:		802.11ac(HT80)		Frequency:		5210MHz	
Antenna Pol.	Frequency (MHz)	Reading Level (dBuV)	Factor (dB/m)	Measure Level (dBuV/m)	Limit (dBuV/m)	Over limit(dB)	Detector
H	5350.00	23.55	17.20	40.75	54.00	-13.25	AV
V	5350.00	26.44	17.20	43.64	54.00	-10.36	AV

Band4

802.11a

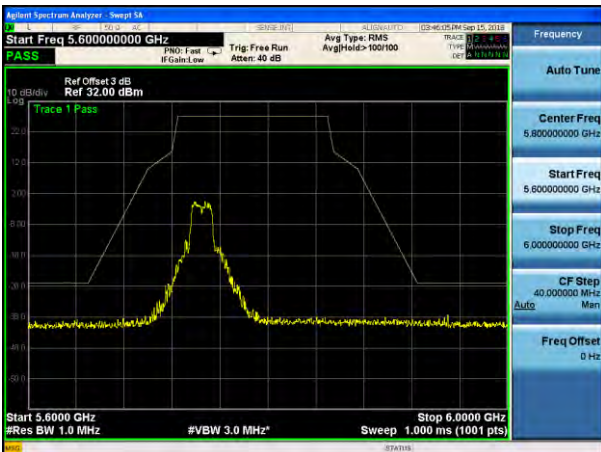

Low: 5745MHz

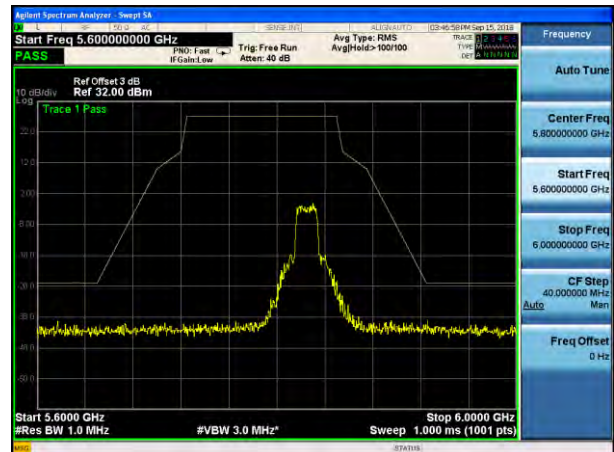

High: 5825MHz

802.11n(HT20)

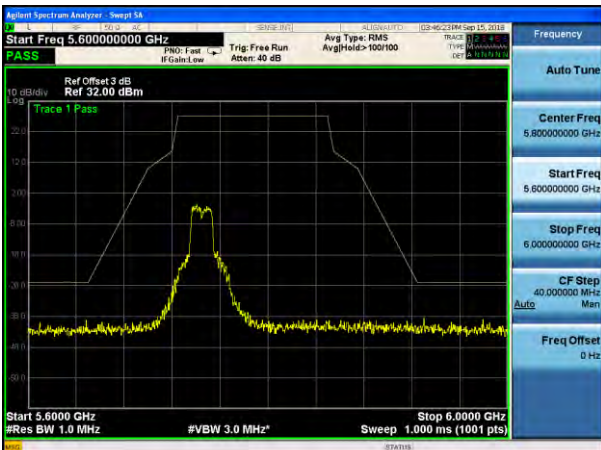

Low: 5745MHz

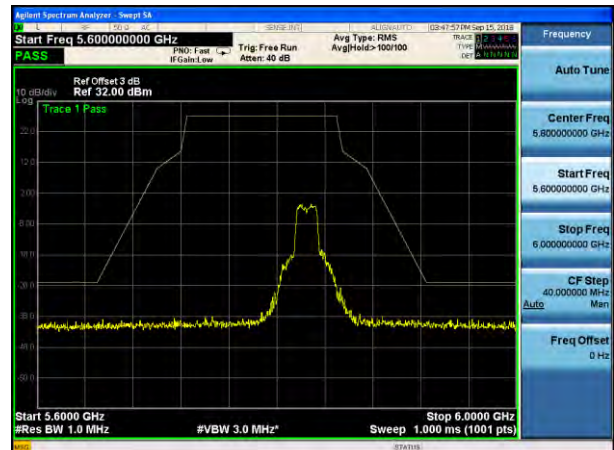

High: 5825MHz

802.11ac(HT20)

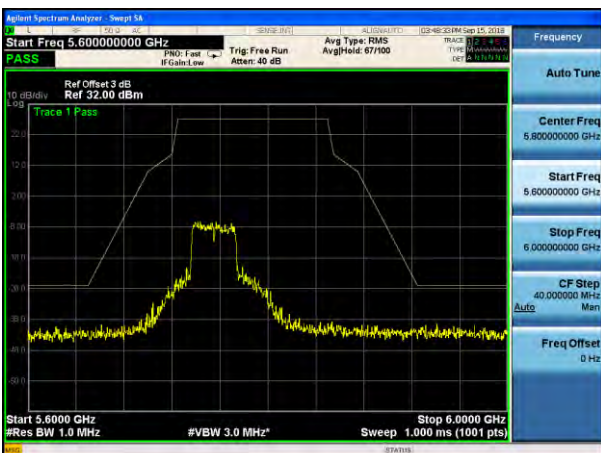

Low: 5745MHz

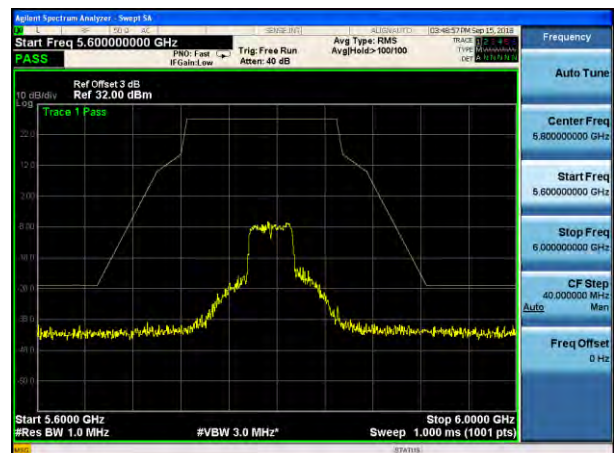

High: 5825MHz

802.11n(HT40)

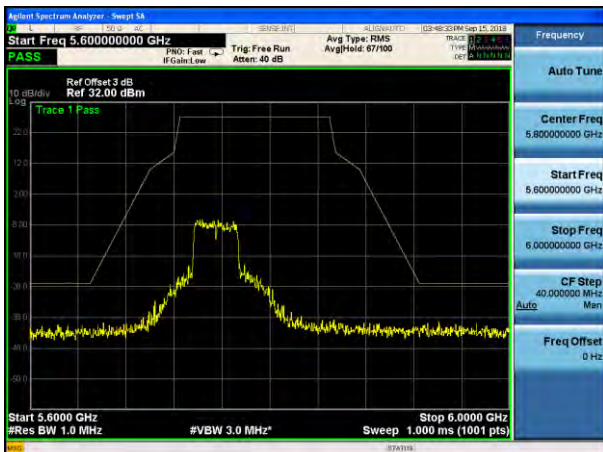

Low: 5755MHz

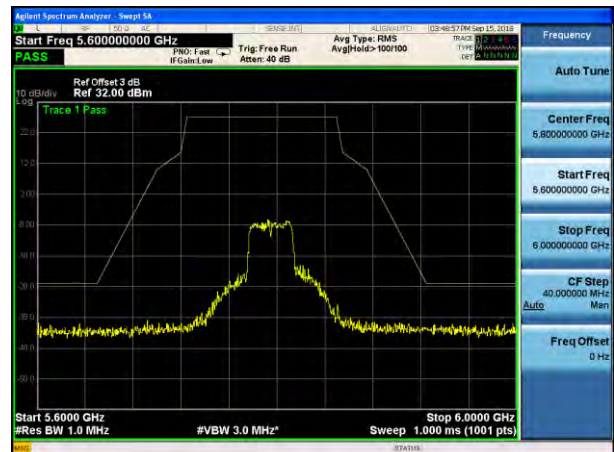

High: 5795MHz

802.11ac(HT40)

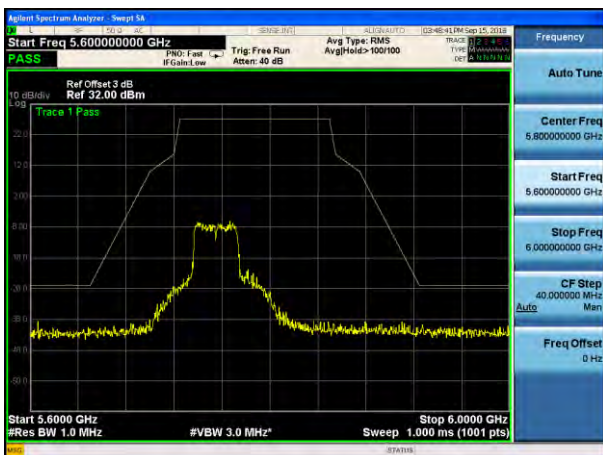

Low: 5755MHz

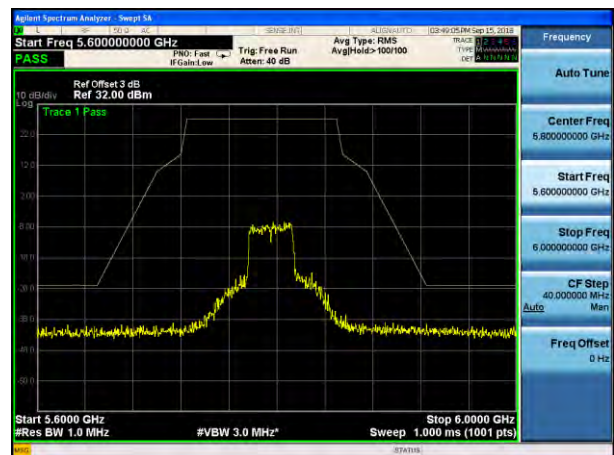

High: 5795MHz

802.11ac(HT80)



5775MHz

4.6 Radiated Emission

Test Requirement:	FCC Part15 C Section 15.209 and 15.205				
Test Method:	ANSI C63.10:2013				
Test Frequency Range:	30MHz to 40GHz				
Test site:	Measurement Distance: 3m (Semi-Anechoic Chamber)				
Receiver setup:	Frequency	Detector	RBW	VBW	Value
	30MHz-1GHz	Quasi-peak	100KHz	300KHz	Quasi-peak Value
	Above 1GHz	Peak	1MHz	3MHz	Peak Value
		AV	1MHz	3MHz	Average Value
Limit:	Frequency		Limit (dBuV/m @3m)		Remark
	30MHz-88MHz		40.0		Quasi-peak Value
	88MHz-216MHz		43.5		Quasi-peak Value
	216MHz-960MHz		46.0		Quasi-peak Value
	960MHz-1GHz		54.0		Quasi-peak Value
	Above 1GHz		74.0		Peak Value
		54.0		Average Value	
Test Procedure:	<p>Substitution method was performed to determine the actual ERP emission levels of the EUT. The following test procedure as below:</p> <p>1>.Below 1GHz test procedure:</p> <ol style="list-style-type: none"> 1. The EUT was placed on the top of a rotating table (0.8m for below 1GHz and 1.5 meters for above 1GHz) above the ground at a 3 meter camber. The table was rotated 360 degrees to determine the position of the highest radiation. 2. The EUT was set 3 meters away from the interference-receiving antenna, which was mounted on the top of a variable-height antenna tower. 3. The antenna height is varied from one meter to four meters above the ground to determine the maximum value of the field strength. Both horizontal and vertical polarizations of the antenna are set to make the measurement. 4. For each suspected emission, the EUT was arranged to its worst case and then the antenna was tuned to heights from 1 meter to 4 meters and the rotatable table was turned from 0 degrees to 360 degrees to find the maximum reading. 5. The test-receiver system was set to Peak Detect Function and Specified Bandwidth with Maximum Hold Mode. 6. If the emission level of the EUT in peak mode was 10dB lower than the limit specified, then testing could be stopped and the peak values of the EUT would be reported. Otherwise the emissions that did not have 10dB margin would be re-tested one by one using peak, quasi-peak or average method as specified and then reported in a data sheet. <p>2>.Above 1GHz test procedure:</p> <ol style="list-style-type: none"> 1. On the test site as test setup graph above,the EUT shall be placed at the 1.5m support on the turntable and in the position closest to normal use as declared by the provider. 2. The test antenna shall be oriented initially for vertical polarization and shall be chosen to correspond to the frequency of the transmitter.The output of the test antenna shall be connected to the measuring receiver. 3. The transmitter shall be switched on, if possible, without modulation and the measuring receiver shall be tuned to the frequency of the 				

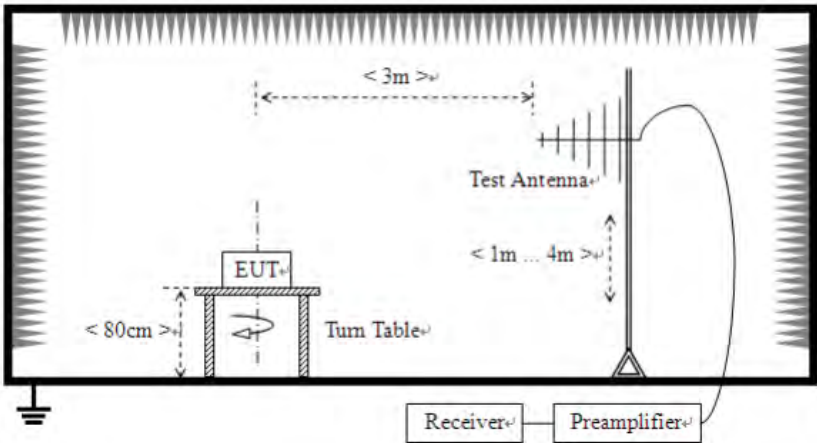
	<p>transmitter under test.</p> <ol style="list-style-type: none"> 4. The test antenna shall be raised and lowered from 1m to 4m until a maximum signal level is detected by the measuring receiver. Then the turntable should be rotated through 360° in the horizontal plane, until the maximum signal level is detected by the measuring receiver. 5. Repeat step 4 for test frequency with the test antenna polarized horizontally. 6. Remove the transmitter and replace it with a substitution antenna 7. Feed the substitution antenna at the transmitter end with a signal generator connected to the antenna by means of a nonradiating cable. With the antennas at both ends vertically polarized, and with the signal generator tuned to a particular test frequency, raise and lower the test antenna to obtain a maximum reading at the spectrum analyzer. Adjust the level of the signal generator output until the previously recorded maximum reading for this set of conditions is obtained. This should be done carefully repeating the adjustment of the test antenna and generator output. 8. Repeat step 7 with both antennas horizontally polarized for each test frequency. 9. Calculate power in dBm into a reference ideal half-wave dipole antenna by reducing the readings obtained in steps 7 and 8 by the power loss in the cable between the generator and the antenna, and further corrected for the gain of the substitution antenna used relative to an ideal half-wave dipole antenna by the following formula: $\text{EIRP(dBm)} = \text{Pg(dBm)} - \text{cable loss (dB)} + \text{antenna gain (dBi)}$ where: Pg is the generator output power into the substitution antenna.
Test setup:	<p>Below 1GHz</p>  <p>Above 1GHz</p>

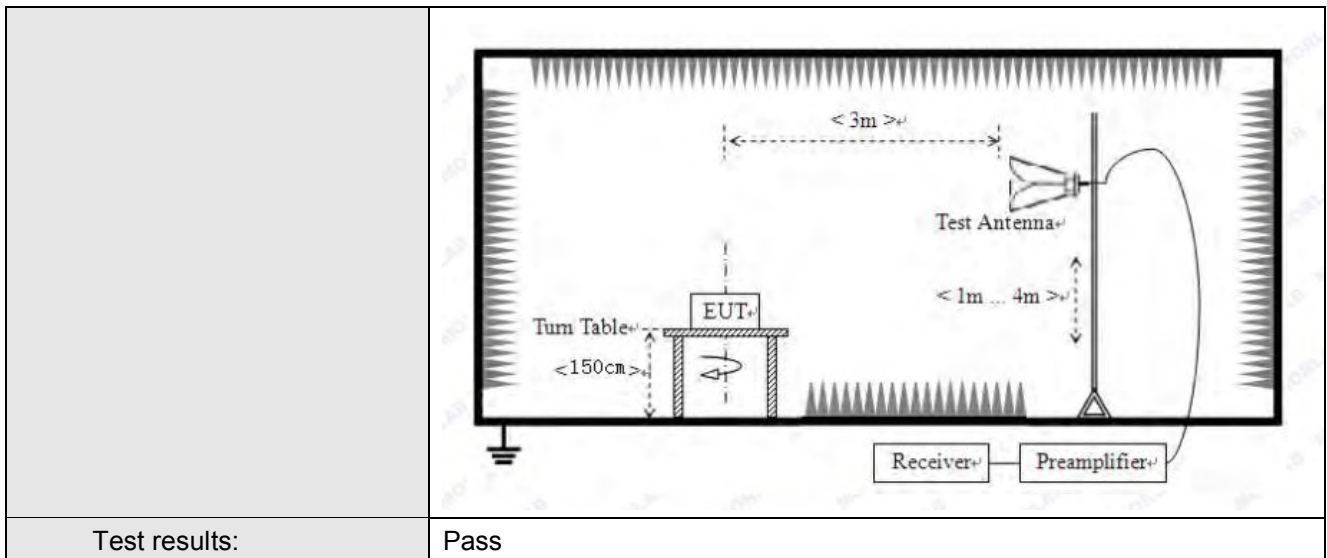

Measurement Data:
Vertical:

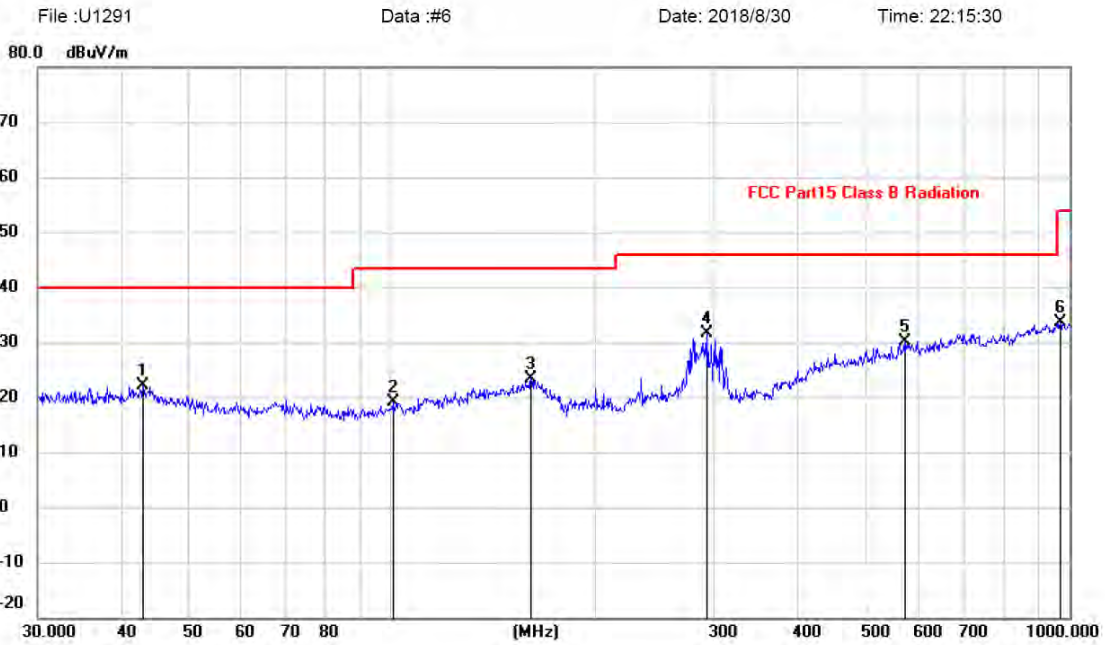

No.	Mk.	Freq.	Reading Level	Correct Factor	Measurement	Limit	Margin	Antenna Height	Table Degree	
		MHz	dBuV	dB	dBuV/m	dBuV/m	dB	cm	degree	Comment
1		43.0504	8.11	13.93	22.04	40.00	-17.96			peak
2		100.2286	8.48	10.63	19.11	43.50	-24.39			peak
3		160.3456	8.94	14.56	23.50	43.50	-20.00			peak
4	*	292.0583	18.35	13.20	31.55	46.00	-14.45			peak
5		570.6100	11.01	19.13	30.14	46.00	-15.86			peak
6		972.3373	9.82	23.77	33.59	54.00	-20.41			peak

Note:1. *:Maximum data; x:Over limit; !:over margin.

2.Measurement=Reading Level+Correct Factor; Correct Factor=Antenna Factor+Cable Loss.

Horizontal

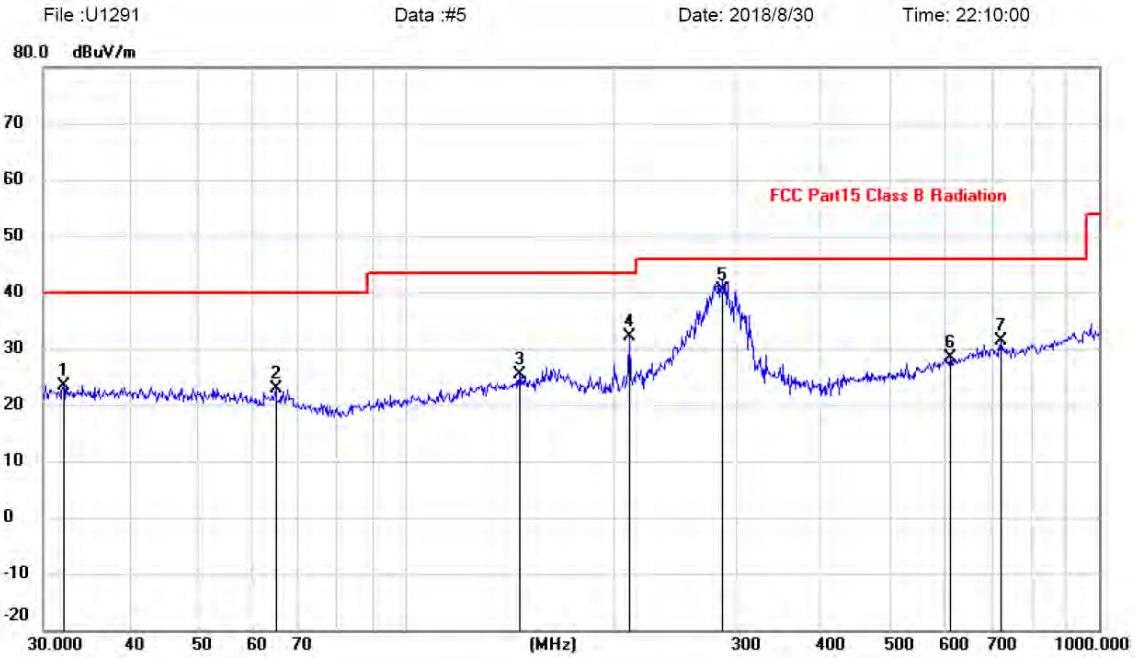

No.	Mk.	Freq.	Reading Level	Correct Factor	Measurement	Limit	Margin	Antenna Height	Table Degree
		MHz	dBuV	dB	dBuV/m	dBuV/m	dB	cm	degree
1		32.0667	10.06	13.39	23.45	40.00	-16.55	peak	
2		64.8865	10.99	11.88	22.87	40.00	-17.13	peak	
3		145.8611	11.11	14.25	25.36	43.50	-18.14	peak	
4		210.0482	21.41	10.69	32.10	43.50	-11.40	peak	
5	*	285.9778	27.22	13.06	40.28	46.00	-5.72	QP	
6		609.9217	8.57	19.77	28.34	46.00	-17.66	peak	
7		724.2610	10.10	21.24	31.34	46.00	-14.66	peak	

Note: 1. *:Maximum data; x:Over limit; !:over margin.

2.Measurement=Reading Level+Correct Factor; Correct Factor=Antenna Factor+Cable Loss.

NOTE: Test Result 802.11 n/HT40 (High Channel, ANT1+ANT2), AC 120V/60Hz (Worst Case)

Above 1GHz:**(worst case : ANT2)****802.11a(HT20) 5180MHz**

Frequency (MHz)	Read Level (dBuV)	Antenna Factor (dB/m)	Cable Loss (dB)	Preamp Factor (dB)	Level (dBuV/m)	Limit Line (dBuV/m)	Over Limit (dB)	polarization
10360	20.24	39.67	14.62	32.65	41.88	74.00	-32.12	Vertical
15540	25.18	38.60	17.66	34.46	46.98	74.00	-27.02	Vertical
10360	24.41	39.67	14.62	32.65	46.05	74.00	-27.95	Horizontal
15540	22.98	38.60	17.66	34.46	44.78	74.00	-29.22	Horizontal

802.11a(HT20) 5200MHz

Frequency (MHz)	Read Level (dBuV)	Antenna Factor (dB/m)	Cable Loss (dB)	Preamp Factor (dB)	Level (dBuV/m)	Limit Line (dBuV/m)	Over Limit (dB)	polarization
10400	21.82	39.67	14.62	32.65	43.46	74.00	-30.54	Vertical
15600	23.33	38.60	17.66	34.46	45.13	74.00	-28.87	Vertical
10400	22.22	39.67	14.62	32.65	43.86	74.00	-30.14	Horizontal
15600	24.49	38.60	17.66	34.46	46.29	74.00	-27.71	Horizontal

802.11a(HT20) 5240MHz

Frequency (MHz)	Read Level (dBuV)	Antenna Factor (dB/m)	Cable Loss (dB)	Preamp Factor (dB)	Level (dBuV/m)	Limit Line (dBuV/m)	Over Limit (dB)	polarization
10480	23.66	39.67	14.62	32.65	45.30	74.00	-28.70	Vertical
15720	22.03	38.60	17.66	34.46	43.83	74.00	-30.17	Vertical
10480	24.00	39.67	14.62	32.65	45.64	74.00	-28.36	Horizontal
15720	24.75	38.60	17.66	34.46	46.55	74.00	-27.45	Horizontal

(worst case : ANT1+ANT2)**802.11n(HT20) 5180MHz**

Frequency (MHz)	Read Level (dBuV)	Antenna Factor (dB/m)	Cable Loss (dB)	Preamp Factor (dB)	Level (dBuV/m)	Limit Line (dBuV/m)	Over Limit (dB)	polarization
10360	20.35	39.67	14.62	32.65	41.99	74.00	-32.01	Vertical
15540	20.21	38.60	17.66	34.46	42.01	74.00	-31.99	Vertical
10360	27.45	39.67	14.62	32.65	49.09	74.00	-24.91	Horizontal
15540	26.17	38.60	17.66	34.46	47.97	74.00	-26.03	Horizontal

802.11n(HT20) 5200MHz

Frequency (MHz)	Read Level (dBuV)	Antenna Factor (dB/m)	Cable Loss (dB)	Preamp Factor (dB)	Level (dBuV/m)	Limit Line (dBuV/m)	Over Limit (dB)	polarization
10400	23.70	39.67	14.62	32.65	45.34	74.00	-28.66	Vertical
15600	25.96	38.60	17.66	34.46	47.76	74.00	-26.24	Vertical
10400	24.74	39.67	14.62	32.65	46.38	74.00	-27.62	Horizontal
15600	21.41	38.60	17.66	34.46	43.21	74.00	-30.79	Horizontal

802.11n(HT20) 5240MHz

Frequency (MHz)	Read Level (dBuV)	Antenna Factor (dB/m)	Cable Loss (dB)	Preamp Factor (dB)	Level (dBuV/m)	Limit Line (dBuV/m)	Over Limit (dB)	polarization
10480	24.95	39.67	14.62	32.65	46.59	74.00	-27.41	Vertical
15720	23.12	38.60	17.66	34.46	44.92	74.00	-29.08	Vertical
10480	20.66	39.67	14.62	32.65	42.30	74.00	-31.70	Horizontal
15720	21.79	38.60	17.66	34.46	43.59	74.00	-30.41	Horizontal

(worst case : ANT1+ANT2)**802.11ac(HT20) 5180MHz**

Frequency (MHz)	Read Level (dBuV)	Antenna Factor (dB/m)	Cable Loss (dB)	Preamp Factor (dB)	Level (dBuV/m)	Limit Line (dBuV/m)	Over Limit (dB)	polarization
10360	22.67	39.67	14.62	32.65	44.31	74.00	-29.69	Vertical
15540	22.85	38.60	17.66	34.46	44.65	74.00	-29.35	Vertical
10360	24.01	39.67	14.62	32.65	45.65	74.00	-28.35	Horizontal
15540	25.99	38.60	17.66	34.46	47.79	74.00	-26.21	Horizontal

802.11ac(HT20) 5200MHz

Frequency (MHz)	Read Level (dBuV)	Antenna Factor (dB/m)	Cable Loss (dB)	Preamp Factor (dB)	Level (dBuV/m)	Limit Line (dBuV/m)	Over Limit (dB)	polarization
10400	21.58	39.67	14.62	32.65	43.22	74.00	-30.78	Vertical
15600	26.34	38.60	17.66	34.46	48.14	74.00	-25.86	Vertical
10400	26.79	39.67	14.62	32.65	48.43	74.00	-25.57	Horizontal
15600	20.84	38.60	17.66	34.46	42.64	74.00	-31.36	Horizontal

802.11ac(HT20) 5240MHz

Frequency (MHz)	Read Level (dBuV)	Antenna Factor (dB/m)	Cable Loss (dB)	Preamp Factor (dB)	Level (dBuV/m)	Limit Line (dBuV/m)	Over Limit (dB)	polarization
10480	24.50	39.67	14.62	32.65	46.14	74.00	-27.86	Vertical
15720	21.51	38.60	17.66	34.46	43.31	74.00	-30.69	Vertical
10480	23.95	39.67	14.62	32.65	45.59	74.00	-28.41	Horizontal
15720	24.07	38.60	17.66	34.46	45.87	74.00	-28.13	Horizontal

(worst case : ANT1+ANT2)**802.11n(HT40) 5190MHz**

Frequency (MHz)	Read Level (dBuV)	Antenna Factor (dB/m)	Cable Loss (dB)	Preamp Factor (dB)	Level (dBuV/m)	Limit Line (dBuV/m)	Over Limit (dB)	polarization
10380	22.69	39.67	14.62	32.65	44.33	74.00	-29.67	Vertical
15570	23.87	38.60	17.66	34.46	45.67	74.00	-28.33	Vertical
10380	23.53	39.67	14.62	32.65	45.17	74.00	-28.83	Horizontal
15570	24.12	38.60	17.66	34.46	45.92	74.00	-28.08	Horizontal

802.11n(HT40) 5230MHz

Frequency (MHz)	Read Level (dBuV)	Antenna Factor (dB/m)	Cable Loss (dB)	Preamp Factor (dB)	Level (dBuV/m)	Limit Line (dBuV/m)	Over Limit (dB)	polarization
10460	22.57	39.67	14.62	32.65	44.21	74.00	-29.79	Vertical
15690	22.59	38.60	17.66	34.46	44.39	74.00	-29.61	Vertical
10460	22.75	39.67	14.62	32.65	44.39	74.00	-29.61	Horizontal
15690	25.39	38.60	17.66	34.46	47.19	74.00	-26.81	Horizontal

802.11ac(HT40) 5190MHz

Frequency (MHz)	Read Level (dBuV)	Antenna Factor (dB/m)	Cable Loss (dB)	Preamp Factor (dB)	Level (dBuV/m)	Limit Line (dBuV/m)	Over Limit (dB)	polarization
10380	20.43	39.67	14.62	32.65	42.07	74.00	-31.93	Vertical
15570	22.13	38.60	17.66	34.46	43.93	74.00	-30.07	Vertical
10380	24.65	39.67	14.62	32.65	46.29	74.00	-27.71	Horizontal
15570	23.34	38.60	17.66	34.46	45.14	74.00	-28.86	Horizontal

(worst case : ANT1+ANT2)**802.11ac(HT40) 5230MHz**

Frequency (MHz)	Read Level (dBuV)	Antenna Factor (dB/m)	Cable Loss (dB)	Preamp Factor (dB)	Level (dBuV/m)	Limit Line (dBuV/m)	Over Limit (dB)	polarization
10460	25.33	39.67	14.62	32.65	46.97	74.00	-27.03	Vertical
15690	21.77	38.60	17.66	34.46	43.57	74.00	-30.43	Vertical
10460	23.41	39.67	14.62	32.65	45.05	74.00	-28.95	Horizontal
15690	23.57	38.60	17.66	34.46	45.37	74.00	-28.63	Horizontal

(worst case : ANT1+ANT2)**802.11ac(HT80) 5210MHz**

Frequency (MHz)	Read Level (dBuV)	Antenna Factor (dB/m)	Cable Loss (dB)	Preamp Factor (dB)	Level (dBuV/m)	Limit Line (dBuV/m)	Over Limit (dB)	polarization
10420	23.53	39.67	14.62	32.65	45.17	74.00	-28.83	Vertical
15630	23.89	38.60	17.66	34.46	45.69	74.00	-28.31	Vertical
10420	25.26	39.67	14.62	32.65	46.90	74.00	-27.10	Horizontal
15630	25.89	38.60	17.66	34.46	47.69	74.00	-26.31	Horizontal

Note:

1. Level = Read Level + Antenna Factor+ Cable loss- Preamp Factor.
2. The test trace is same as the ambient noise (the test frequency range: 18GHz~40GHz), therefore no data appear in the report.
3. This limit applies for using average detector, if the test result on peak is lower than average limit, then average measurement needn't be performed.

5 Frequency Stability

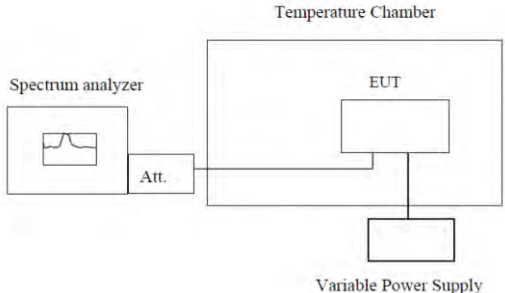
Test Requirement:	FCC Part15 E Section 15.407 (g)
Limit:	Manufacturers of U-NII devices are responsible for ensuring frequency stability such that an emission is maintained within the band of operation under all conditions of normal operation as specified in the user's manual.
Test setup:	 <p>The diagram illustrates the test setup. On the left, a 'Spectrum analyzer' is shown with a small graph on its screen. A line connects it to a box labeled 'Att.' (Attenuator). From the 'Att.' box, a line goes to the 'EUT' (Equipment Under Test) inside a larger box labeled 'Temperature Chamber'. Below the 'Temperature Chamber' box, a line connects to a box labeled 'Variable Power Supply'.</p>
Test procedure:	<ol style="list-style-type: none"> 1. The EUT is installed in an environment test chamber with external power source. 2. Set the chamber to operate at 50 centigrade and external power source to output at nominal voltage of EUT. 3. A sufficient stabilization period at each temperature is used prior to each frequency measurement. 4. When temperature is stabled, measure the frequency stability. 5. The test shall be performed under -30 to 50 centigrade and 85 to 115 percent of the nominal voltage. Change setting of chamber and external power source to complete all conditions.
Test results:	Pass

Measurement Data (the worst channel):

Band 1:

Voltage vs. Frequency Stability (Lowest channel=5180MHz)

Voltage(%)	Power(VDC)	TEMP(°C)	Test Fequency (MHz)	Target Frequency (MHz)	Deviation (ppm)
100%	5.0	-30	5179.967	5180	7.02
100%		-20	5179.975	5180	5.37
100%		-10	5179.968	5180	5.89
100%		0	5179.970	5180	5.76
100%		10	5179.971	5180	4.88
100%		20	5179.969	5180	5.80
100%		30	5179.976	5180	5.47
100%		40	5179.981	5180	4.26
100%		50	5179.973	5180	3.89
Low Battery power		4.25	20	5179.983	5180
High Battery power	5.75	20	5179.987	5180	3.12

Band 4:

Voltage vs. Frequency Stability (Lowest channel=5745MHz)

Voltage(%)	Power(VDC)	TEMP(°C)	Test Fequency (MHz)	Target Frequency (MHz)	Deviation (ppm)
100%	5.0	-30	5744.970	5745	5.29
100%		-20	5744.980	5745	3.55
100%		-10	5744.974	5745	4.49
100%		0	5744.975	5745	4.43
100%		10	5744.971	5745	4.98
100%		20	5744.971	5745	5.00
100%		30	5744.978	5745	3.91
100%		40	5744.979	5745	3.73
100%		50	5744.975	5745	4.29
Low Battery power		4.25	20	5744.971	5745
High Battery power	5.75	20	5744.969	5745	5.39

6 Test Setup Photo

Radiated Emission

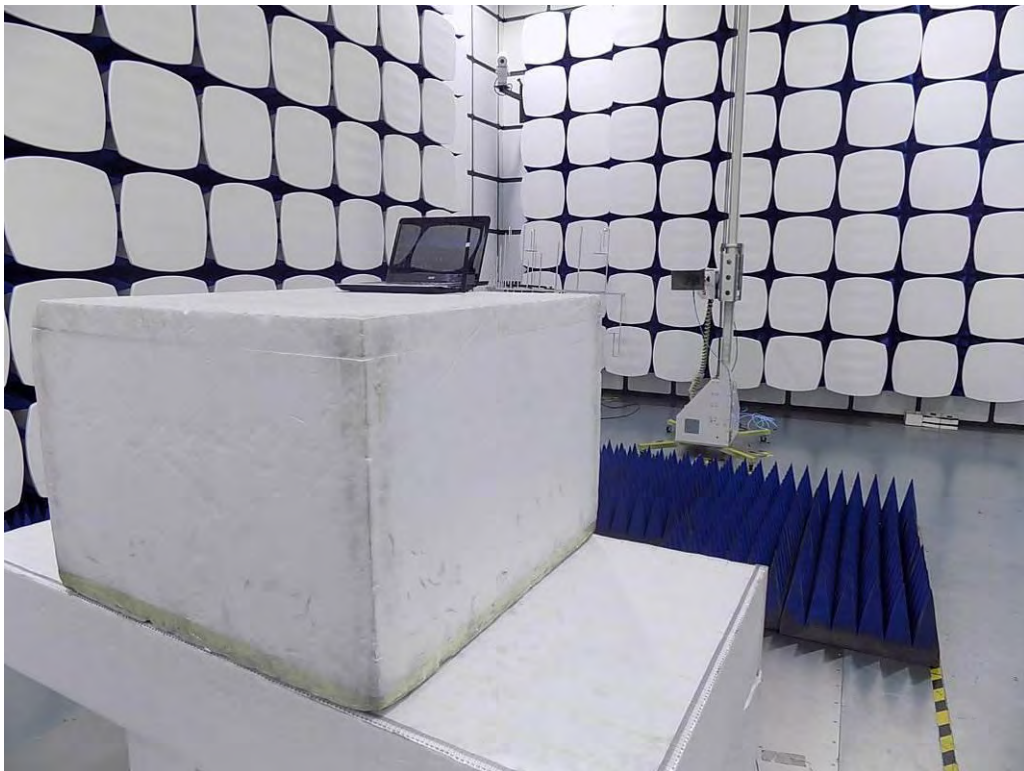
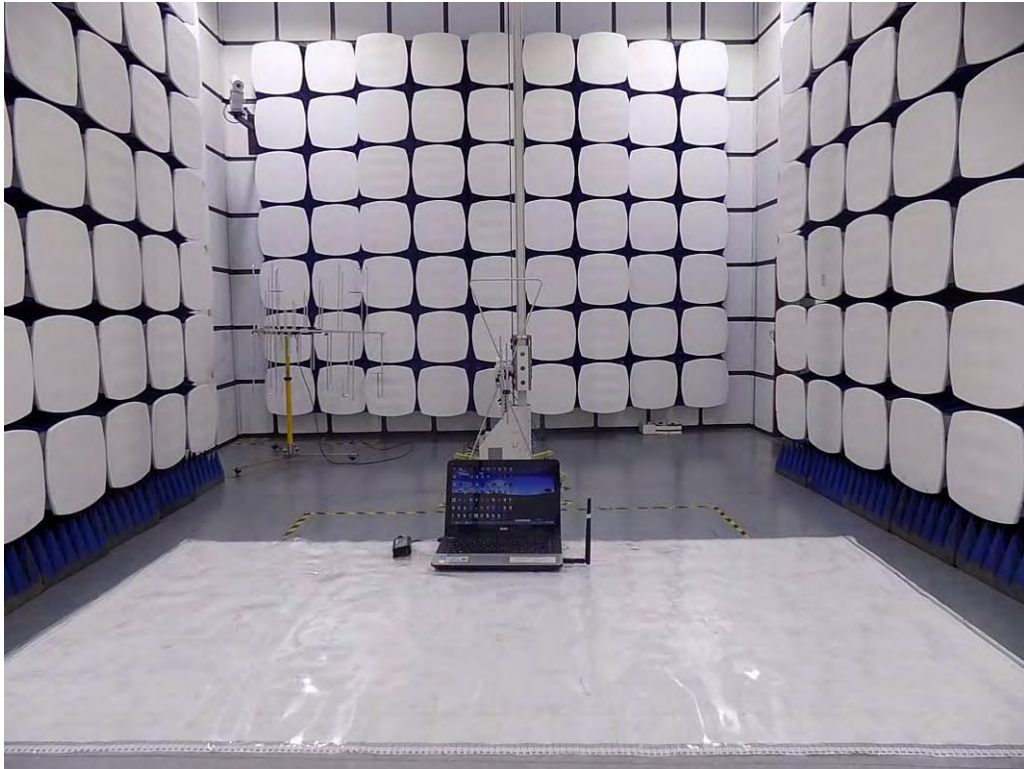

Conducted Emission

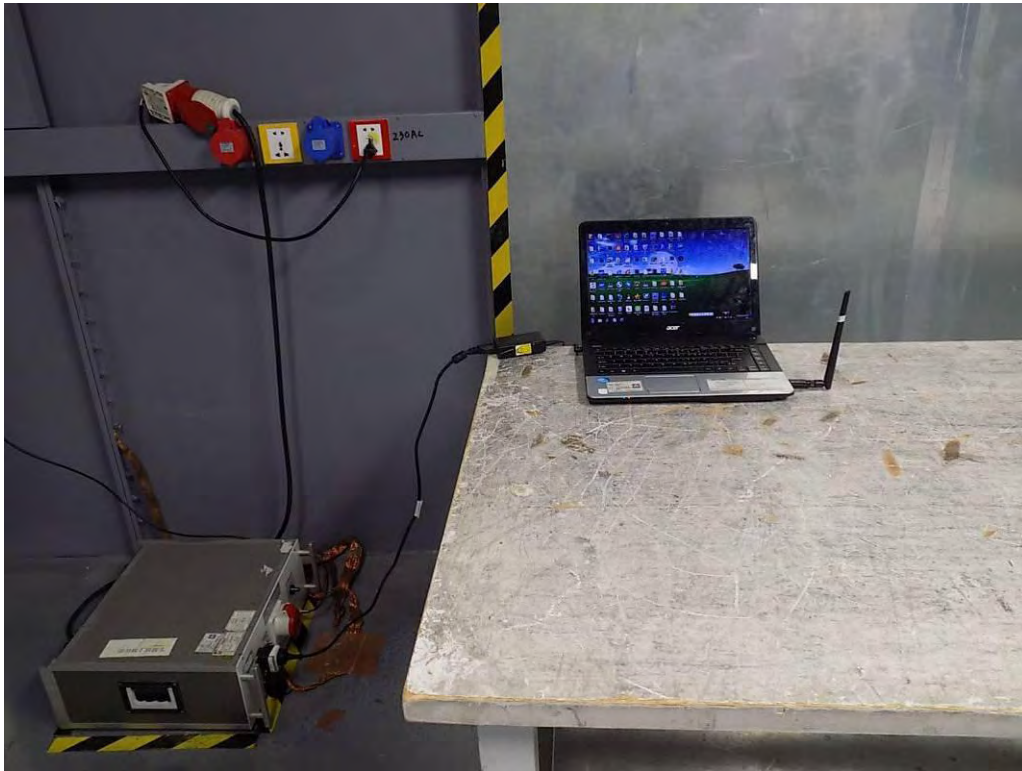

7 EUT Constructional Details

Reference to the test report No. T1881361 01.

---END---