



# TEST REPORT

**FCC ID: 2AAD8-R0300**

For

**HAOLIYUAN(SHENZHEN) ELECTRONIC CO.,LTD**

**802.11n Wireless Router**

Model No. : R0300, WR366E

Trade Name : N/A

Prepared for : HAOLIYUAN(SHENZHEN) ELECTRONIC CO.,LTD  
Address : 3/F, Building A1, Junfeng Industrial Park, Yonghe Road, Fuyong, Bao'an District, Shenzhen, Guangdong, China

Prepared by : Shenzhen Alpha Product Testing Co., Ltd.  
Address : Building B, East Area of Nanchang Second, Industrial Zone, Gushu 2nd Road, Bao'an, Shenzhen, China

Report No. : T1860802 05

Date of Receipt : May 19, 2016

Date of Test : May 19-26, 2016

Date of Report : May 26, 2016

Version Number : REV0

## TABLE OF CONTENT

Description	Page
<b>1. General Information-----</b>	<b>5</b>
1.1 Description of Device (EUT) -----	5
1.2 Description of Test Facility -----	6
<b>2. EMC Equipment List -----</b>	<b>6</b>
<b>3. Test Procedure -----</b>	<b>7</b>
<b>4 Summary of Measurement -----</b>	<b>8</b>
4.1 Summary of test result -----	8
4.2 Test connection -----	8
4.3 Assistant equipment used for test -----	9
4.4 Test mode-----	9
4.5 Channel list-----	9
4.6 Test Conditions -----	10
4.7 Measurement Uncertainty (95% confidence levels, k=2) -----	10
<b>5 Spurious Emission -----</b>	<b>11</b>
5.1 Radiation Emission-----	11
5.1.1 Radiation Emission Limits(15.209)-----	11
5.1.2 Test Setup -----	11
5.1.3 Test Procedure -----	13
5.1.4 Test Equipment Setting For emission test Result -----	13
5.1.5 Test Condition -----	14
5.1.6 Test Result-----	14
<b>6 POWER LINE CONDUCTED EMISSION-----</b>	<b>37</b>
6.1 Conducted Emission Limits(15.207)-----	37
6.2 Test Setup -----	37
6.3 Test Procedure -----	38
6.4 Test Results -----	38
<b>7 Conducted Maximum Output Power -----</b>	<b>43</b>
7.1 Test limit-----	43
7.2 Test Procedure -----	43
7.3 Test Setup -----	43
7.4 Test Results -----	43
<b>8 PEAK POWER SPECTRAL DENSITY -----</b>	<b>45</b>
8.1 Test limit-----	45
8.2 Method of measurement -----	45
8.3 Test Setup -----	45
8.4 Test Results -----	46
<b>9 Bandwidth-----</b>	<b>59</b>
9.1 Test limit-----	59
9.2 Method of measurement -----	59
9.3 Test Setup -----	59
9.4 Test Results -----	59
<b>10 Band Edge Check-----</b>	<b>67</b>

---

10.1	Test limit-----	67
10.2	Test Procedure -----	67
10.3	Test Setup -----	67
10.4	Test Result-----	67
<b>11</b>	<b>Antenna Requirement-----</b>	<b>84</b>
11.1	Standard Requirement -----	84
11.2	Antenna Connected Construction -----	84
11.3	Result -----	84
<b>12</b>	<b>Photographs of Setup-----</b>	<b>85</b>
12.1	Photo of Spurious Emission-----	85
12.2	Photo of Power line conducted emission-----	86
<b>13</b>	<b>Photographs of EUT -----</b>	<b>87</b>



## 1. General Information

### 1.1 Description of Device (EUT)

Trade Name	: N/A
EUT	: 802.11n Wireless Router
Model No.	: R0300, WR366E
DIFF	: All models are the same except the model name, so this report performs R0300.
Antenna Type	: 2PCS Integrated Antenna Max Gain 5dBi
Operation Frequency	IEEE 802.11b/g: 2412MHz-2462MHz (SISO Mode) IEEE 802.11n HT20: 2412MHz-2462MHz (MIMO Mode) IEEE 802.11n HT40: 2422MHz-2452MHz (MIMO Mode) EEE 802.11b/g:11Channels
Channel number	: IEEE 802.11n HT20: 11 Channels IEEE 802.11n HT40: 7Channels
Modulation type	: IEEE 802.11b: DSSS(CCK,DQPSK,DBPSK) IEEE 802.11g: OFDM(64QAM, 16QAM, QPSK, BPSK) IEEE 802.11n :OFDM(64QAM, 16QAM, QPSK, BPSK)
Power Supply	: DC 5V From Adapter with AC 120V/60Hz
Software version	V1.0
Hardware version	V1_0
Applicant	: HAOLIYUAN(SHENZHEN) ELECTRONIC CO.,LTD
Address	: 3/F, Building A1, Junfeng Industrial Park, Yonghe Road, Fuyong, Bao'an District, Shenzhen, Guangdong, China
Manufacture	: HAOLIYUAN(SHENZHEN) ELECTRONIC CO.,LTD
Address	: 3/F, Building A1, Junfeng Industrial Park, Yonghe Road, Fuyong, Bao'an District, Shenzhen, Guangdong, China

## 1.2 Description of Test Facility

Shenzhen Alpha Product Testing Co., Ltd.

Building B, East Area of Nanchang Second, Industrial Zone, Gushu 2nd Road, Bao'an, Shenzhen, China

March 25, 2015 File on Federal Communication Commission

Registration Number: 203110

July 18, 2014 Certificated by IC

Registration Number: 12135A

## 2. EMC Equipment List

Equipment	Manufacture	Model No.	Serial No.	Last cal. Due to	Cal Interval
3m Semi-Anechoic	CHENYU	N/A	N/A	2018.01.18	2Year
Spectrum analyzer	Agilent	E4407B	MY46185649	2017.01.16	1Year
Receiver	R&S	ESPI	101873	2017.01.16	1Year
Receiver	R&S	ESCI	101165	2017.01.16	1Year
Bilog Antenna	SCHWARZBECK	VULB 9168	VULB9168-438	2018.01.18	2Year
Horn Antenna	SCHWARZBECK	BBHA 9120 D	BBHA 9120 D(1201)	2017.01.20	2Year
L.I.S.N.#1	Schwarzbeck	NSLK8126	8126466	2017.01.16	1 Year
L.I.S.N.#2	ROHDE&SCHWARZ	ENV216	101043	2017.01.16	1 Year
Cable	Resenberger	N/A	No.1	2017.01.16	1Year
Cable	SCHWARZBECK	N/A	No.2	2017.01.16	1Year
Cable	SCHWARZBECK	N/A	No.3	2017.01.16	1Year
Pre-amplifier	HP	HP8347A	2834A00455	2017.01.18	1Year
Pre-amplifier	Agilent	8449B	3008A02664	2017.01.18	1Year

vector Signal Generator	Agilent	N5182A	MY49060042	2016.11.16	1 Year
vector Signal Generator	Agilent	E4438C	US44271917	2016.11.16	1 Year
X-series USB Peak and Average Power Sensor	Agilent	U2021XA	MY54080020	2016.11.16	1 Year
X-series USB Peak and Average Power Sensor	Agilent	U2021XA	MY54110001	2016.11.16	1 Year
Signal Analyzer	Agilent	N9020A	MY48030494	2016.11.16	1 Year

### 3. Test Procedure

**POWER LINE CONDUCTED INTERFERENCE:** The test procedure used was ANSI Standard ANSI C63.4:2014 using a 50 u H LISN. Both Lines were observed. The bandwidth of the receiver was 10kHz with an appropriate sweep speed. The ambient temperature of the EUT was 25°C with a humidity of 58%.

**RADIATION INTERFERENCE:** The test procedure used was ANSI Standard ANSI C63.4:2014 using a ANRITSU spectrum analyzer with a pre-selector. The analyzer was calibrated in dB above a micro volt at the output of the antenna. The resolution bandwidth was 100kHz and the video bandwidth was 300 kHz up to 1 GHz and 1 MHz with a video BW of 3MHz above 1 GHz. The ambient temperature of the EUT was 25°C with a humidity of 58%.

**FORMULA OF CONVERSION FACTORS:** The Field Strength at 3m was established by adding the meter reading of the spectrum analyzer (which is set to read in units of dBuV) to the antenna correction factor supplied by the antenna manufacturer and cable loss. The antenna correction factors and cable loss are stated in terms of dB. The gain of the Pre-selector was accounted for in the Spectrum Analyzer Meter Reading.

Example:

Freq (MHz) METER READING + ACF + CABLE = FS

33.20 dBuV + 10.36 dB + 0.9 dB= 44.46 dBuV/m @ 3m

**ANSI STANDARD ANSI C63.4:2014 10.1.7 MEASUREMENT PROCEDURES:** The EUT was placed on a table 80 cm high and with dimensions of 1m by 1.5m. The EUT was placed in the center of the table (1.5m side). The table used for radiated measurements is capable of continuous rotation. When an emission was found, the table was rotated to produce the maximum signal strength. At this point, the antenna was raised and lowered from 1m to 4m. The antenna was placed in both the horizontal and vertical planes. The situation was similar for the conducted measurement except that the table did not rotate. The EUT was setup as described in ANSI Standard ANSI C63.4:2014 10.1.7 with the EUT 40 cm from the vertical ground wall.

## 4 Summary of Measurement

### 4.1 Summary of test result

Test Item	Test Requirement	Standards Paragraph	Result
Spurious Emission	FCC PART 15:2015	Section 15.247&15.209	Compliance
Conduction Emission	FCC PART 15:2015	Section 15.207	Compliance
Bandwidth Test	FCC PART 15:2015	Section 15.247	Compliance
Peak Power	FCC PART 15:2015	Section 15.247	Compliance
Power Density	FCC PART 15:2015	Section 15.247	Compliance
Band Edge	FCC PART 15:2015	Section 15.247 Section 5.5	Compliance
Antenna Requirement	FCC PART 15:2015	Section 15.203	Compliance

Note: The EUT has been tested as an independent unit. And Continual Transmitting in maximum power (The adapter be used during Test)

### 4.2 Test connection

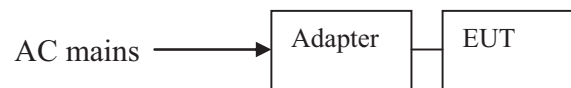



### 4.3 Assistant equipment used for test

Description	:	N/A
Manufacturer	:	N/A
Model No.	:	N/A
Remark: FCC DOC approved		

### 4.4 Test mode

Dutycycle :100% Keeping TX			
Mode	data rate (Mbps)(see Note)	Channel	Frequency (MHz)
IEEE 802.11b	1	Low :CH1	2412
	1	Middle: CH6	2437
	1	High: CH11	2462
IEEE 802.11g	6	Low :CH1	2412
	6	Middle: CH6	2437
	6	High: CH11	2462
IEEE 802.11 n/HT20 with 2.4G	6.5	Low :CH1	2412
	6.5	Middle: CH6	2437
	6.5	High: CH11	2462
IEEE 802.11 n/HT40 with 2.4G	13.5	Low :CH3	2422
	13.5	Middle:CH6	2437
	13.5	High:CH9	2452

Note: According exploratory test, EUT will have maximum output power in those data rate. so those data rate were used for all test.  
Note: Only 802.11n Mode can keep in MIMO mode.

### 4.5 Channel list

For IEEE 802.11b/g and IEEE 802.11n/HT20 with 2.4G					
Channel	Frequency (MHz)	Channel	Frequency (MHz)	Channel	Frequency (MHz)
CH1	2412	CH5	2432	CH9	2452
CH2	2417	CH6	2437	CH10	2457
CH3	2422	CH7	2442	CH11	2462
CH4	2427	CH8	2447		

For IEEE 802.11n/HT40 with 2.4G					
Channel	Frequency (MHz)	Channel	Frequency (MHz)	Channel	Frequency (MHz)
CH1	/	CH5	2432	CH9	2452
CH2	/	CH6	2437	/	/
CH3	2422	CH7	2442	/	/
CH4	2427	CH8	2447	/	/

#### 4.6 Test Conditions

Temperature range	21-25°C
Humidity range	40-75%
Pressure range	86-106kPa

#### 4.7 Measurement Uncertainty (95% confidence levels, k=2)

Item	MU	Remark
Uncertainty for Power point Conducted Emissions Test	2.71dB	
Uncertainty for Radiation Emission test in 3m chamber (below 30MHz)	2.13 dB	Polarize: V
	2.57dB	Polarize: H
Uncertainty for Radiation Emission test in 3m chamber (30MHz to 1GHz)	3.90 dB	Polarize: V
	3.92dB	Polarize: H
Uncertainty for Radiation Emission test in 3m chamber (1GHz to 25GHz)	4.26 dB	Polarize: H
	4.28 dB	Polarize: V
Uncertainty for radio frequency	$1 \times 10^{-9}$	
Uncertainty for conducted RF Power	0.65dB	
Uncertainty for temperature	0.2°C	
Uncertainty for humidity	1%	
Uncertainty for DC and low frequency voltages	0.06%	

## 5 Spurious Emission

### 5.1 Radiation Emission

#### 5.1.1 Radiation Emission Limits(15.209)

Frequencies (MHz)	Field Strength (micorvolts/meter)	Measurement Distance (meters)
0.009~0.490	2400/F(KHz)	300
0.490~1.705	24000/F(KHz)	30
1.705~30.0	30	30
30~88	100	3
88~216	150	3
216~960	200	3
Above 960	500	3

Harmonic emissions limits comply with below 54 dBuV/m at 3m. Other emissions radiated outside of the specified frequency bands, except for harmonics, shall be attenuated by at least 50 dB below the level of the fundamental or comply with the radiated emissions limits specified in section 15.209(a) limit in the table below has to be followed.

**NOTE:**

- a) The tighter limit applies at the band edges.
- b) Emission Level(dB uV/m)=20log Emission Level(uv/m)

#### 5.1.2 Test Setup

See the next page

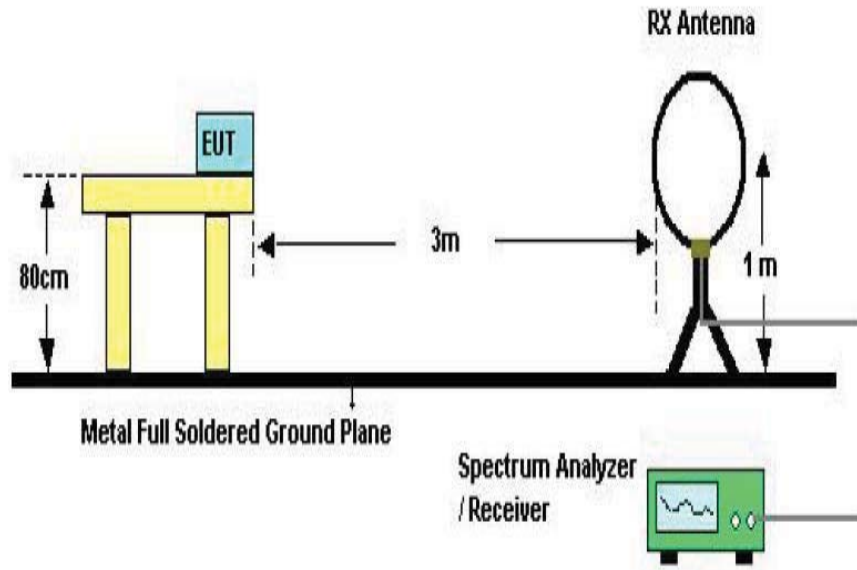

Below 30MHz Test Setup

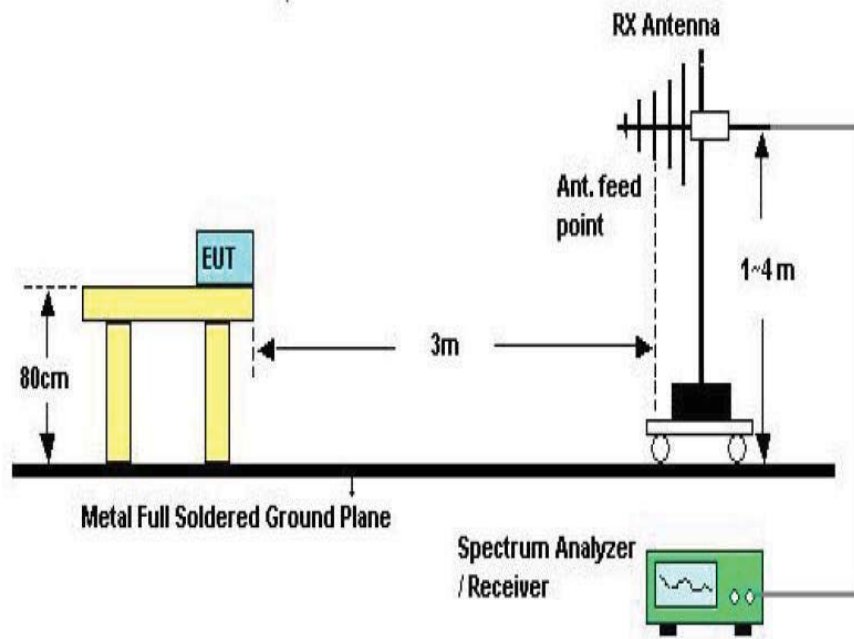

Above 30MHz Test Setup

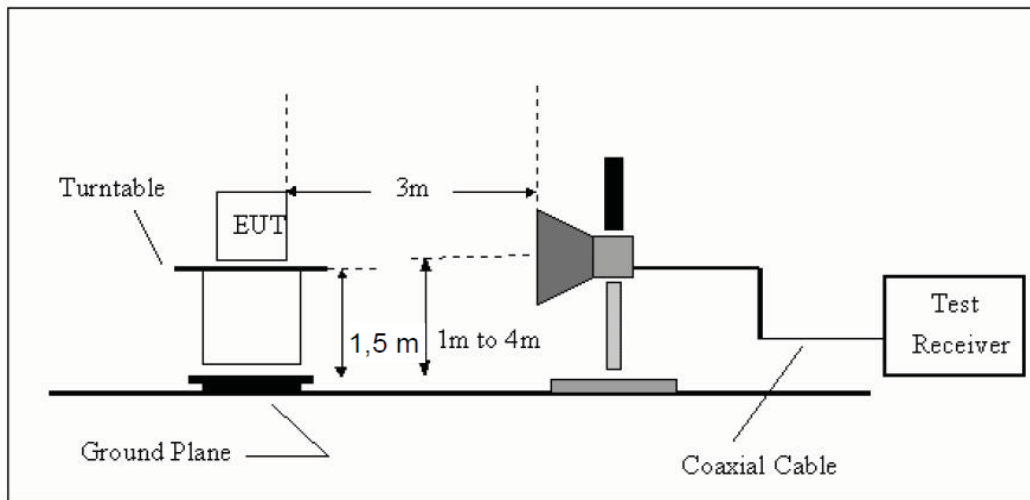

Above 1GHz Test Setup

### 5.1.3 Test Procedure

- The measuring distance of 3m shall be used for measurements at frequency up to 1GHz and above 1GHz, The EUT was placed on a rotating 0.8 m high above ground for below 1GHz and 1.5m high for above 1GHz testing, The table was rotated 360 degrees to determine the position of the highest radiation
- The Test antenna shall vary between 1m and 4m, Both Horizontal and Vertical antenna are set to make measurement.
- The initial step in collecting conducted emission data is a spectrum analyzer Peak detector mode pre-scanning the measurement frequency range. Significant Peaks are then marked. and then Quasi Peak Detector mode premeasured
- If Peak value comply with QP limit Below 1GHz. The EUT deemed to comply with QP limit. But the Peak value and average value both need to comply with applicable limit above 1GHz.
- For the actual test configuration, please see the test setup photo.

### 5.1.4 Test Equipment Setting For emission test Result

9KHz~150KHz	RBW 200Hz	VBW 1KHz
150KHz~30MHz	RBW 9KHz	VBW 30KHz
30MHz~1GHz	RBW 120KHz	VBW 300KHz
Above 1GHz	RBW 1MHz	VBW 3MHz

### 5.1.5 Test Condition

Continual Transmitting in maximum power.

### 5.1.6 Test Result

#### TX MODE

All modes have been tested , and only worse case of 802.11 b mode is reported only.

We have scanned the 9KHz from 25GHz to the EUT.

Detailed information please see the following page.

From 9KHz to 30MHz:      Conclusion: PASS

Note: The amplitude of spurious emissions which are attenuated by more than 20dB below the permissible value has no need to be reported.

802.11b ant1:



Shenzhen Alpha Product Testing Co., Ltd  
 Building B, East Area of Nanchang Second Industrial Zone,  
 Gushu 2nd Road, Bao'an District, Shenzhen 518126, P.R. China  
 Tel: +86-755-29766001 FAX: +86-755-86375565  
 Website: <http://www.a-lab.cn> Email: [service@a-lab.cn](mailto:service@a-lab.cn)

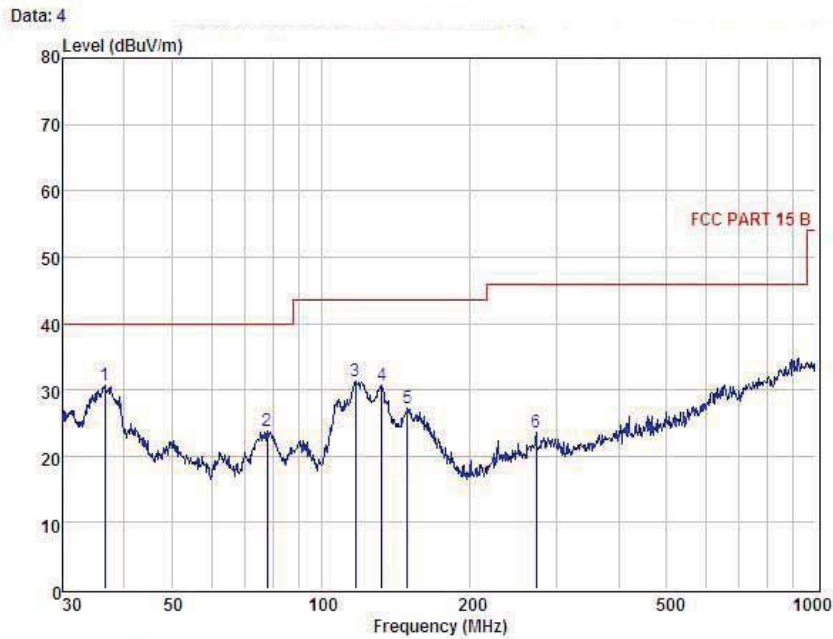

Condition : FCC PART 15 B 3m POL: VERTICAL  
 EUT :  
 Model No :  
 Test Mode :  
 Power :  
 Test Engineer :  
 Remark :  
 Temp : 24.2°C  
 Hum : 54%

Item	Freq MHz	Read Level dBuV	Antenna Factor dB	Preamp Factor dB	Cable Loss dB	Level dBuV	Limit dBuV	Margin dBuV	Remark
1	36.51	47.98	13.39	30.83	0.10	30.64	40.00	-9.36	Peak
2	77.87	43.62	9.60	30.01	0.29	23.70	40.00	-16.30	Peak
3	117.36	48.91	11.87	29.74	0.37	31.41	43.50	-12.09	Peak
4	132.69	46.68	12.93	29.44	0.53	30.70	43.50	-12.80	Peak
5	149.49	42.26	14.03	29.45	0.35	27.19	43.50	-16.31	Peak
6	272.28	38.86	12.15	28.12	0.66	23.55	46.00	-22.45	Peak

Remark: Level = Read Level + Antenna Factor - Preamp Factor + Cable Loss



Shenzhen Alpha Product Testing Co., Ltd  
 Building B, East Area of Nanchang Second Industrial Zone,  
 Gushu 2nd Road, Bao'an District, Shenzhen 518126, P.R. China  
 Tel: +86-755-29766001 FAX: +86-755-86375565  
 Website: <http://www.a-lab.cn> Email: [service@a-lab.cn](mailto:service@a-lab.cn)

Data: 3

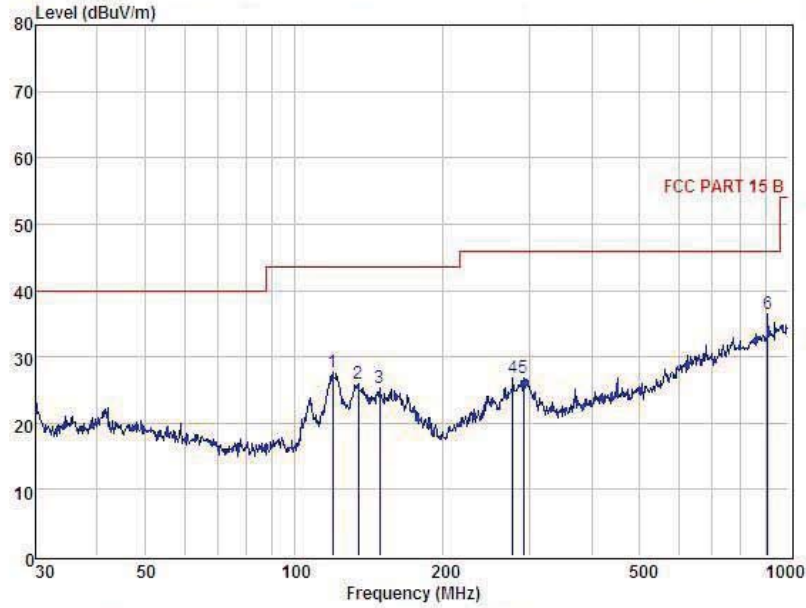

Condition : FCC PART 15 B 3m POL: HORIZONTAL  
 EUT :  
 Model No :  
 Test Mode :  
 Power :  
 Test Engineer :  
 Remark :  
 Temp : 24.2°C  
 Hum : 54%

Item	Freq MHz	Read Level dBuV	Antenna Factor dB	Preamp Factor dB	Cable Loss dB	Level dBuV	Limit dBuV	Margin dBuV	Remark
1	119.86	44.99	12.06	29.68	0.36	27.73	43.50	-15.77	Peak
2	135.03	41.86	13.08	29.41	0.46	25.99	43.50	-17.51	Peak
3	148.96	40.32	14.03	29.45	0.35	25.25	43.50	-18.25	Peak
4	277.09	42.10	12.31	28.09	0.49	26.81	46.00	-19.19	Peak
5	291.04	41.55	12.62	28.04	0.61	26.74	46.00	-19.26	Peak
6	906.48	38.38	21.74	25.11	1.49	36.50	46.00	-9.50	Peak

Remark: Level = Read Level + Antenna Factor - Preamp Factor + Cable Loss



802.11b ant2:



Shenzhen Alpha Product Testing Co., Ltd  
 Building B, East Area of Nanchang Second Industrial Zone,  
 Gushu 2nd Road, Bao'an District, Shenzhen 518126, P.R. China  
 Tel: +86-755-29766001 FAX: +86-755-86375565  
 Website: <http://www.a-lab.cn> Email: [service@a-lab.cn](mailto:service@a-lab.cn)

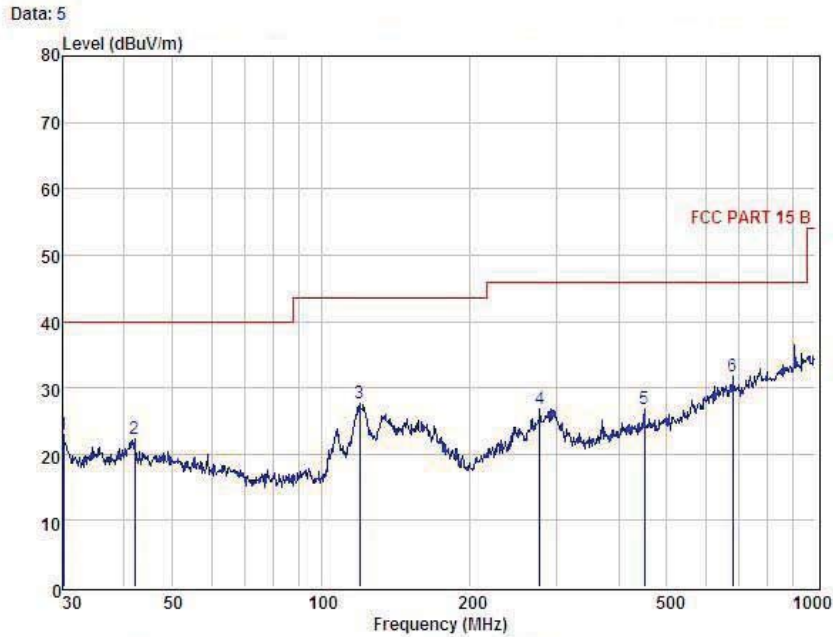

Condition : FCC PART 15 B 3m POL: HORIZONTAL  
 EUI :  
 Model No :  
 Test Mode :  
 Power :  
 Test Engineer :  
 Remark :  
 Temp : 24.2°C  
 Hum : 54%

Item	Freq MHz	Read Level dBUV	Antenna Factor dB	Preamp Factor dB	Cable Loss dB	Level dBUV	Limit dBUV	Margin dBUV	Remark
1	30.11	40.66	13.22	30.98	0.03	22.93	40.00	-17.07	Peak
2	42.01	38.62	13.93	30.40	0.19	22.34	40.00	-17.66	Peak
3	119.86	44.99	12.06	29.68	0.36	27.73	43.50	-15.77	Peak
4	277.09	42.10	12.31	28.09	0.49	26.81	46.00	-19.19	Peak
5	461.14	37.33	15.99	27.54	1.08	26.86	46.00	-19.14	Peak
6	679.96	36.46	19.44	25.80	1.70	31.80	46.00	-14.20	Peak

Remark: Level = Read Level + Antenna Factor - Preamp Factor + Cable Loss



Shenzhen Alpha Product Testing Co., Ltd  
 Building B, East Area of Nanchang Second Industrial Zone,  
 Gushu 2nd Road, Bao'an District, Shenzhen 518126, P.R. China  
 Tel: +86-755-29766001 FAX: +86-755-86375565  
 Website: <http://www.a-lab.cn> Email: [service@a-lab.cn](mailto:service@a-lab.cn)

Data: 6

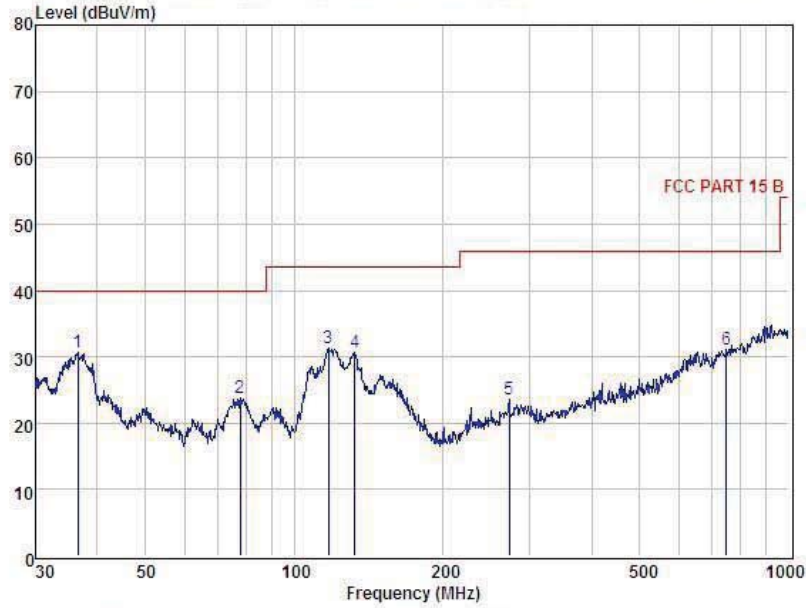

Condition : FCC PART 15 B 3m POL: VERTICAL  
 EUT :  
 Model No :  
 Test Mode :  
 Power :  
 Test Engineer :  
 Remark :  
 Temp : 24.2°C  
 Hum : 54%

Item	Freq MHz	Read Level dBuV	Antenna Factor dB	Preamp Factor dB	Cable Loss dB	Level dBuV	Limit dBuV	Margin dBuV	Remark
1	36.51	47.98	13.39	30.83	0.10	30.64	40.00	-9.36	Peak
2	77.87	43.82	9.60	30.01	0.29	23.70	40.00	-16.30	Peak
3	117.36	48.91	11.87	29.74	0.37	31.41	43.50	-12.09	Peak
4	132.69	46.68	12.93	29.44	0.53	30.70	43.50	-12.80	Peak
5	272.28	38.86	12.15	28.12	0.66	23.55	46.00	-22.45	Peak
6	747.48	35.18	20.22	25.35	1.08	31.13	46.00	-14.87	Peak

Remark: Level = Read Level + Antenna Factor - Preamp Factor + Cable Loss

From 1G-25GHz

<b>EUT</b>	802.11n Wireless Router	<b>Model Name</b>	R0300
<b>Temperature</b>	26°C	<b>Relative Humidity</b>	56%
<b>Pressure</b>	960hPa	<b>Test voltage</b>	DC 5V From Adapter with AC 120V/60Hz
<b>Test Mode</b>	TX Low		

IEEE 802.11b ant1:

Freq. (MHz)	Ant. Pol H/V	Peak Reading (dBuV)	AV Reading (dBuV)	Ant. / CL CF (dB)	Actual Fs		Peak Limit (dBuV/m)	AV Limit (dBuV/m)	Margin (dB)	Remarks
					Peak (dBuV/m)	AV (dBuV/m)				
1103	V	44.24	---	-11.24	33	---	74	54	41	Peak
4824	V	36.44	---	0.64	37.08	---	74	54	36.92	Peak
N/A										

<b>EUT</b>	802.11n Wireless Router	<b>Model Name</b>	R0300
<b>Temperature</b>	26°C	<b>Relative Humidity</b>	56%
<b>Pressure</b>	960hPa	<b>Test voltage</b>	DC 5V From Adapter with AC 120V/60Hz
<b>Test Mode</b>	TX Low		

Freq. (MHz)	Ant. Pol H/V	Peak Reading (dBuV)	AV Reading (dBuV)	Ant. / CL CF (dB)	Actual Fs		Peak Limit (dBuV/m)	AV Limit (dBuV/m)	Margin (dB)	Remarks
					Peak (dBuV/m)	AV (dBuV/m)				
1103	H	43.49	---	-11.24	32.25	---	74	54	41.75	Peak
4824	H	35.99	---	0.64	36.63	---	74	54	37.37	Peak
N/A										

**Notes:** AV Means AV detector test data, Peak Means Peak detector test data.

Emissions attenuated more than 20 dB below the permissible value are not reported.

<b>EUT</b>	802.11n Wireless Router	<b>Model Name</b>	R0300
<b>Temperature</b>	26°C	<b>Relative Humidity</b>	56%
<b>Pressure</b>	960hPa	<b>Test voltage</b>	DC 5V From Adapter with AC 120V/60Hz
<b>Test Mode</b>	TX Mid		

Freq. (MHz)	Ant. Pol H/V	Peak Reading (dBuV)	AV Reading (dBuV)	Ant. / CL CF (dB)	Actual Fs		Peak Limit (dBuV/m)	AV Limit (dBuV/m)	Margin (dB)	Remark
					Peak (dBuV/m)	AV (dBuV/m)				
1103	V	42.73	---	-11.24	31.49	---	74	54	42.51	Peak
4874	V	38.59	---	0.76	39.35	---	74	54	34.65	Peak

<b>EUT</b>	802.11n Wireless Router	<b>Model Name</b>	R0300
<b>Temperature</b>	26°C	<b>Relative Humidity</b>	56%
<b>Pressure</b>	960hPa	<b>Test voltage</b>	DC 5V From Adapter with AC 120V/60Hz
<b>Test Mode</b>	TX Mid		

Freq. (MHz)	Ant. Pol H/V	Peak Reading (dBuV)	AV Reading (dBuV)	Ant. / CL CF (dB)	Actual Fs		Peak Limit (dBuV/m)	AV Limit (dBuV/m)	Margin (dB)	Remark
					Peak (dBuV/m)	AV (dBuV/m)				
1103	H	42.77	---	-11.24	31.53	---	74	54	42.47	Peak
4874	H	39.42	---	0.76	40.18	---	74	54	33.82	Peak

**Notes:** AV Means AV detector test data, Peak Means Peak detector test data.

Emissions attenuated more than 20 dB below the permissible value are not reported.

<b>EUT</b>	802.11n Wireless Router	<b>Model Name</b>	R0300
<b>Temperature</b>	26°C	<b>Relative Humidity</b>	56%
<b>Pressure</b>	960hPa	<b>Test voltage</b>	DC 5V From Adapter with AC 120V/60Hz
<b>Test Mode</b>	TX High		

Freq. (MHz)	Ant. Pol H/V	Peak Reading (dBuV)	AV Reading (dBuV)	Ant. / CL CF (dB)	Actual Fs		Peak Limit (dBuV/m)	AV Limit (dBuV/m)	Margin (dB)	Remark
					Peak (dBuV/m)	AV (dBuV/m)				
1103	V	42.45	---	-11.24	31.21	---	74	54	42.79	Peak
4924	V	34.35	---	0.87	35.22	---	74	54	38.78	Peak

<b>EUT</b>	802.11n Wireless Router	<b>Model Name</b>	R0300
<b>Temperature</b>	26°C	<b>Relative Humidity</b>	56%
<b>Pressure</b>	960hPa	<b>Test voltage</b>	DC 5V From Adapter with AC 120V/60Hz
<b>Test Mode</b>	TX High		

Freq. (MHz)	Ant. Pol H/V	Peak Reading (dBuV)	AV Reading (dBuV)	Ant. / CL CF (dB)	Actual Fs		Peak Limit (dBuV/m)	AV Limit (dBuV/m)	Margin (dB)	Remark
					Peak (dBuV/m)	AV (dBuV/m)				
1103	H	43.12	---	-11.24	31.88	---	74	54	42.12	Peak
4924	H	32.97	---	0.87	33.84	---	74	54	40.16	Peak

**Notes:** AV Means AV detector test data, Peak Means Peak detector test data.

Emissions attenuated more than 20 dB below the permissible value are not reported.

IEEE 802.11 g ant1:

<b>EUT</b>	802.11n Wireless Router	<b>Model Name</b>	R0300
<b>Temperature</b>	26°C	<b>Relative Humidity</b>	56%
<b>Pressure</b>	960hPa	<b>Test voltage</b>	DC 5V From Adapter with AC 120V/60Hz
<b>Test Mode</b>	TX Low		

Freq. (MHz)	Ant. Pol H/V	Peak Reading (dBuV)	AV Reading (dBuV)	Ant. / CL CF (dB)	Actual Fs		Peak Limit (dBuV/m)	AV Limit (dBuV/m)	Margin (dB)	Remark
					Peak (dBuV/m)	AV (dBuV/m)				
1145	V	43.59	---	-11.24	32.35	---	74	54	41.65	Peak
2586	V	45.66	---	-7.13	38.53	---	74	54	35.47	Peak
3062	V	43.72	---	-5.74	37.98	---	74	54	36.02	Peak
4824	V	43.32	---	0.64	43.96	---	74	54	30.04	Peak
N/A										

<b>EUT</b>	802.11n Wireless Router	<b>Model Name</b>	R0300
<b>Temperature</b>	26°C	<b>Relative Humidity</b>	56%
<b>Pressure</b>	960hPa	<b>Test voltage</b>	DC 5V From Adapter with AC 120V/60Hz
<b>Test Mode</b>	TX Low		

Freq. (MHz)	Ant. Pol H/V	Peak Reading (dBuV)	AV Reading (dBuV)	Ant. / CL CF (dB)	Actual Fs		Peak Limit (dBuV/m)	AV Limit (dBuV/m)	Margin (dB)	Remark
					Peak (dBuV/m)	AV (dBuV/m)				
1294	H	42.93	---	-10.96	31.97	---	74	54	42.03	Peak
2038	H	43.12	---	-8.58	34.54	---	74	54	39.46	Peak
3483	H	42.02	---	-4.95	37.07	---	74	54	36.93	Peak
4824	H	40.82	---	0.64	41.46	---	74	54	32.54	Peak
N/A										

**Notes:** AV Means AV detector test data, Peak Means Peak detector test data.

Emissions attenuated more than 20 dB below the permissible value are not reported.

<b>EUT</b>	802.11n Wireless Router	<b>Model Name</b>	R0300
<b>Temperature</b>	26°C	<b>Relative Humidity</b>	56%
<b>Pressure</b>	960hPa	<b>Test voltage</b>	DC 5V From Adapter with AC 120V/60Hz
<b>Test Mode</b>	TX Mid		

Freq. (MHz)	Ant. Pol H/V	Peak Reading (dBuV)	AV Reading (dBuV)	Ant. / CL CF (dB)	Actual Fs		Peak Limit (dBuV/m)	AV Limit (dBuV/m)	Margin (dB)	Remark
					Peak (dBuV/m)	AV (dBuV/m)				
1374	V	43.12	---	-10.84	32.28	---	74	54	41.72	Peak
2589	V	43.82	---	-7.46	36.36	---	74	54	37.64	Peak
3365	V	42.11	---	-4.76	37.35	---	74	54	36.65	Peak
4874	V	39.82	---	0.76	40.58	---	74	54	33.42	Peak

<b>EUT</b>	802.11n Wireless Router	<b>Model Name</b>	R0300
<b>Temperature</b>	26°C	<b>Relative Humidity</b>	56%
<b>Pressure</b>	960hPa	<b>Test voltage</b>	DC 5V From Adapter with AC 120V/60Hz
<b>Test Mode</b>	TX Mid		

Freq. (MHz)	Ant. Pol H/V	Peak Reading (dBuV)	AV Reading (dBuV)	Ant. / CL CF (dB)	Actual Fs		Peak Limit (dBuV/m)	AV Limit (dBuV/m)	Margin (dB)	Remark
					Peak (dBuV/m)	AV (dBuV/m)				
1321	H	43.12	---	-10.84	32.28	---	74	54	41.72	Peak
2314	H	43.82	---	-7.46	36.36	---	74	54	37.64	Peak
3577	H	42.11	---	-4.76	37.35	---	74	54	36.65	Peak
4874	H	39.82	---	0.76	40.58	---	74	54	33.42	Peak

**Notes:** AV Means AV detector test data, Peak Means Peak detector test data.

Emissions attenuated more than 20 dB below the permissible value are not reported.

<b>EUT</b>	802.11n Wireless Router	<b>Model Name</b>	R0300
<b>Temperature</b>	26°C	<b>Relative Humidity</b>	56%
<b>Pressure</b>	960hPa	<b>Test voltage</b>	DC 5V From Adapter with AC 120V/60Hz
<b>Test Mode</b>	TX High		

Freq. (MHz)	Ant. Pol H/V	Peak Reading (dBuV)	AV Reading (dBuV)	Ant. / CL CF (dB)	Actual Fs		Peak Limit (dBuV/m)	AV Limit (dBuV/m)	Margin (dB)	Remark
					Peak (dBuV/m)	AV (dBuV/m)				
1302	V	43.12	---	-10.84	32.28	---	74	54	41.72	Peak
2982	V	43.66	---	-5.86	37.8	---	74	54	36.2	Peak
3831	V	42.72	---	-3.96	38.76	---	74	54	35.24	Peak
4924	V	41.12	---	0.87	41.99	---	74	54	32.01	Peak

<b>EUT</b>	802.11n Wireless Router	<b>Model Name</b>	R0300
<b>Temperature</b>	26°C	<b>Relative Humidity</b>	56%
<b>Pressure</b>	960hPa	<b>Test voltage</b>	DC 5V From Adapter with AC 120V/60Hz
<b>Test Mode</b>	TX High		

Freq. (MHz)	Ant. Pol H/V	Peak Reading (dBuV)	AV Reading (dBuV)	Ant. / CL CF (dB)	Actual Fs		Peak Limit (dBuV/m)	AV Limit (dBuV/m)	Margin (dB)	Remark
					Peak (dBuV/m)	AV (dBuV/m)				
1446	H	43.3	---	-10.29	33.01	---	74	54	40.99	Peak
2198	H	42.12	---	-8.24	33.88	---	74	54	40.12	Peak
3905	H	43.22	---	-3.68	39.54	---	74	54	34.46	Peak
4924	H	40.7	---	0.87	41.57	---	74	54	32.43	Peak

**Notes:** AV Means AV detector test data, Peak Means Peak detector test data.  
Emissions attenuated more than 20 dB below the permissible value are not reported.



IEEE 802.11b ant2:

Freq. (MHz)	Ant. Pol H/V	Peak Reading (dBuV)	AV Reading (dBuV)	Ant. / CL CF (dB)	Actual Fs		Peak Limit (dBuV/m)	AV Limit (dBuV/m)	Margin (dB)	Remark
					Peak (dBuV/m)	AV (dBuV/m)				
1103	V	43.74	---	-11.24	32.5	---	74	54	41.5	Peak
4824	V	35.4	---	0.64	36.04	---	74	54	37.96	Peak
N/A										

<b>EUT</b>	802.11n Wireless Router	<b>Model Name</b>	R0300
<b>Temperature</b>	26°C	<b>Relative Humidity</b>	56%
<b>Pressure</b>	960hPa	<b>Test voltage</b>	DC 5V From Adapter with AC 120V/60Hz
<b>Test Mode</b>	TX Low		

Freq. (MHz)	Ant. Pol H/V	Peak Reading (dBuV)	AV Reading (dBuV)	Ant. / CL CF (dB)	Actual Fs		Peak Limit (dBuV/m)	AV Limit (dBuV/m)	Margin (dB)	Remark
					Peak (dBuV/m)	AV (dBuV/m)				
1103	H	43.99	---	-11.24	32.75	---	74	54	41.25	Peak
4824	H	36.77	---	0.64	37.41	---	74	54	36.59	Peak
N/A										

**Notes:** AV Means AV detector test data, Peak Means Peak detector test data.

Emissions attenuated more than 20 dB below the permissible value are not reported.

<b>EUT</b>	802.11n Wireless Router	<b>Model Name</b>	R0300
<b>Temperature</b>	26°C	<b>Relative Humidity</b>	56%
<b>Pressure</b>	960hPa	<b>Test voltage</b>	DC 5V From Adapter with AC 120V/60Hz
<b>Test Mode</b>	TX Mid		

Freq. (MHz)	Ant. Pol H/V	Peak Reading (dBuV)	AV Reading (dBuV)	Ant. / CL CF (dB)	Actual Fs		Peak Limit (dBuV/m)	AV Limit (dBuV/m)	Margin (dB)	Remark
					Peak (dBuV/m)	AV (dBuV/m)				
1103	V	44.09	---	-11.24	32.85	---	74	54	41.15	Peak
4874	V	39.32	---	0.76	40.08	---	74	54	33.92	Peak

<b>EUT</b>	802.11n Wireless Router	<b>Model Name</b>	R0300
<b>Temperature</b>	26°C	<b>Relative Humidity</b>	56%
<b>Pressure</b>	960hPa	<b>Test voltage</b>	DC 5V From Adapter with AC 120V/60Hz
<b>Test Mode</b>	TX Mid		

Freq. (MHz)	Ant. Pol H/V	Peak Reading (dBuV)	AV Reading (dBuV)	Ant. / CL CF (dB)	Actual Fs		Peak Limit (dBuV/m)	AV Limit (dBuV/m)	Margin (dB)	Remark
					Peak (dBuV/m)	AV (dBuV/m)				
1103	H	43.61	---	-11.24	32.37	---	74	54	41.63	Peak
4874	H	38.21	---	0.76	38.97	---	74	54	35.03	Peak

**Notes:** AV Means AV detector test data, Peak Means Peak detector test data.

Emissions attenuated more than 20 dB below the permissible value are not reported.

<b>EUT</b>	802.11n Wireless Router	<b>Model Name</b>	R0300
<b>Temperature</b>	26°C	<b>Relative Humidity</b>	56%
<b>Pressure</b>	960hPa	<b>Test voltage</b>	DC 5V From Adapter with AC 120V/60Hz
<b>Test Mode</b>	TX High		

Freq. (MHz)	Ant. Pol H/V	Peak Reading (dBuV)	AV Reading (dBuV)	Ant. / CL CF (dB)	Actual Fs		Peak Limit (dBuV/m)	AV Limit (dBuV/m)	Margin (dB)	Remark
					Peak (dBuV/m)	AV (dBuV/m)				
1103	V	43.83	---	-11.24	32.59	---	74	54	41.41	Peak
4924	V	38.68	---	0.87	39.55	---	74	54	34.45	Peak

<b>EUT</b>	802.11n Wireless Router	<b>Model Name</b>	R0300
<b>Temperature</b>	26°C	<b>Relative Humidity</b>	56%
<b>Pressure</b>	960hPa	<b>Test voltage</b>	DC 5V From Adapter with AC 120V/60Hz
<b>Test Mode</b>	TX High		

Freq. (MHz)	Ant. Pol H/V	Peak Reading (dBuV)	AV Reading (dBuV)	Ant. / CL CF (dB)	Actual Fs		Peak Limit (dBuV/m)	AV Limit (dBuV/m)	Margin (dB)	Remark
					Peak (dBuV/m)	AV (dBuV/m)				
1103	H	44.18	---	-11.24	32.94	---	74	54	41.06	Peak
4924	H	34.97	---	0.87	35.84	---	74	54	38.16	Peak

**Notes:** AV Means AV detector test data, Peak Means Peak detector test data.

Emissions attenuated more than 20 dB below the permissible value are not reported.

IEEE 802.11 g ant2:

<b>EUT</b>	802.11n Wireless Router	<b>Model Name</b>	R0300
<b>Temperature</b>	26°C	<b>Relative Humidity</b>	56%
<b>Pressure</b>	960hPa	<b>Test voltage</b>	DC 5V From Adapter with AC 120V/60Hz
<b>Test Mode</b>	TX Low		

Freq. (MHz)	Ant. Pol H/V	Peak Reading (dBuV)	AV Reading (dBuV)	Ant. / CL CF (dB)	Actual Fs		Peak Limit (dBuV/m)	AV Limit (dBuV/m)	Margin (dB)	Remark
					Peak (dBuV/m)	AV (dBuV/m)				
1145	V	43.3	---	-10.27	33.03	---	74	54	40.97	Peak
2586	V	42.89	---	-6.94	35.95	---	74	54	38.05	Peak
3062	V	43.08	---	-3.68	39.4	---	74	54	34.6	Peak
4824	V	41.83	---	0.64	42.47	---	74	54	31.53	Peak
N/A										

<b>EUT</b>	802.11n Wireless Router	<b>Model Name</b>	R0300
<b>Temperature</b>	26°C	<b>Relative Humidity</b>	56%
<b>Pressure</b>	960hPa	<b>Test voltage</b>	DC 5V From Adapter with AC 120V/60Hz
<b>Test Mode</b>	TX Low		

Freq. (MHz)	Ant. Pol H/V	Peak Reading (dBuV)	AV Reading (dBuV)	Ant. / CL CF (dB)	Actual Fs		Peak Limit (dBuV/m)	AV Limit (dBuV/m)	Margin (dB)	Remark
					Peak (dBuV/m)	AV (dBuV/m)				
1294	H	43.33	---	-10.27	33.06	---	74	54	40.94	Peak
2038	H	43.6	---	-6.17	37.43	---	74	54	36.57	Peak
3483	H	43.17	---	-4.52	38.65	---	74	54	35.35	Peak
4824	H	42.09	---	0.64	42.73	---	74	54	31.27	Peak
N/A										

**Notes:** AV Means AV detector test data, Peak Means Peak detector test data.

Emissions attenuated more than 20 dB below the permissible value are not reported.

<b>EUT</b>	802.11n Wireless Router	<b>Model Name</b>	R0300
<b>Temperature</b>	26°C	<b>Relative Humidity</b>	56%
<b>Pressure</b>	960hPa	<b>Test voltage</b>	DC 5V From Adapter with AC 120V/60Hz
<b>Test Mode</b>	TX Mid		

Freq. (MHz)	Ant. Pol H/V	Peak Reading (dBuV)	AV Reading (dBuV)	Ant. / CL CF (dB)	Actual Fs		Peak Limit (dBuV/m)	AV Limit (dBuV/m)	Margin (dB)	Remark
					Peak (dBuV/m)	AV (dBuV/m)				
1374	V	43.02	---	-10.96	32.06	---	74	54	41.94	Peak
2589	V	43.46	---	-8.58	34.88	---	74	54	39.12	Peak
3365	V	42.7	---	-4.07	38.63	---	74	54	35.37	Peak
4874	V	41.82	---	0.76	42.58	---	74	54	31.42	Peak

<b>EUT</b>	802.11n Wireless Router	<b>Model Name</b>	R0300
<b>Temperature</b>	26°C	<b>Relative Humidity</b>	56%
<b>Pressure</b>	960hPa	<b>Test voltage</b>	DC 5V From Adapter with AC 120V/60Hz
<b>Test Mode</b>	TX Mid		

Freq. (MHz)	Ant. Pol H/V	Peak Reading (dBuV)	AV Reading (dBuV)	Ant. / CL CF (dB)	Actual Fs		Peak Limit (dBuV/m)	AV Limit (dBuV/m)	Margin (dB)	Remark
					Peak (dBuV/m)	AV (dBuV/m)				
1321	H	42.92	---	-10.14	32.78	---	74	54	41.22	Peak
2314	H	43.08	---	-7.59	35.49	---	74	54	38.51	Peak
3577	H	43.35	---	-5.39	37.96	---	74	54	36.04	Peak
4874	H	42.09	---	0.76	42.85	---	74	54	31.15	Peak

**Notes:** AV Means AV detector test data, Peak Means Peak detector test data.

Emissions attenuated more than 20 dB below the permissible value are not reported.

<b>EUT</b>	802.11n Wireless Router	<b>Model Name</b>	R0300
<b>Temperature</b>	26°C	<b>Relative Humidity</b>	56%
<b>Pressure</b>	960hPa	<b>Test voltage</b>	DC 5V From Adapter with AC 120V/60Hz
<b>Test Mode</b>	TX High		

Freq. (MHz)	Ant. Pol H/V	Peak Reading (dBuV)	AV Reading (dBuV)	Ant. / CL CF (dB)	Actual Fs		Peak Limit (dBuV/m)	AV Limit (dBuV/m)	Margin (dB)	Remark
					Peak (dBuV/m)	AV (dBuV/m)				
1302	V	44.35	---	-10.27	34.08	---	74	54	39.92	Peak
2982	V	43.23	---	-6.43	36.8	---	74	54	37.2	Peak
3831	V	43.12	---	-4.76	38.36	---	74	54	35.64	Peak
4924	V	41.95	---	0.87	42.82	---	74	54	31.18	Peak

<b>EUT</b>	802.11n Wireless Router	<b>Model Name</b>	R0300
<b>Temperature</b>	26°C	<b>Relative Humidity</b>	56%
<b>Pressure</b>	960hPa	<b>Test voltage</b>	DC 5V From Adapter with AC 120V/60Hz
<b>Test Mode</b>	TX High		

Freq. (MHz)	Ant. Pol H/V	Peak Reading (dBuV)	AV Reading (dBuV)	Ant. / CL CF (dB)	Actual Fs		Peak Limit (dBuV/m)	AV Limit (dBuV/m)	Margin (dB)	Remark
					Peak (dBuV/m)	AV (dBuV/m)				
1446	H	42.9	---	-10.14	32.76	---	74	54	41.24	Peak
2198	H	43.2	---	-4.96	38.24	---	74	54	35.76	Peak
3905	H	43.01	---	-2.48	40.53	---	74	54	33.47	Peak
4924	H	41.06	---	0.87	41.93	---	74	54	32.07	Peak

**Notes:** AV Means AV detector test data, Peak Means Peak detector test data.  
Emissions attenuated more than 20 dB below the permissible value are not reported.

IEEE 802.11n/HT20 with 2.4G

<b>EUT</b>	802.11n Wireless Router	<b>Model Name</b>	R0300
<b>Temperature</b>	26°C	<b>Relative Humidity</b>	56%
<b>Pressure</b>	960hPa	<b>Test voltage</b>	DC 5V From Adapter with AC 120V/60Hz
<b>Test Mode</b>	MIMO TX Low		

Freq. (MHz)	Ant. Pol H/V	Peak Reading (dBuV)	AV Reading (dBuV)	Ant. / CL CF (dB)	Actual Fs		Peak Limit (dBuV/m)	AV Limit (dBuV/m)	Margin (dB)	Remark
					Peak (dBuV/m)	AV (dBuV/m)				
1492	V	43.36	---	-10.07	33.29	---	74	54	40.71	Peak
2671	V	43.23	---	-6.94	36.29	---	74	54	37.71	Peak
3948	V	42.52	---	-4.95	37.57	---	74	54	36.43	Peak
4824	V	41.11	---	0.64	41.75	---	74	54	32.25	Peak
N/A										

<b>EUT</b>	802.11n Wireless Router	<b>Model Name</b>	R0300
<b>Temperature</b>	26°C	<b>Relative Humidity</b>	56%
<b>Pressure</b>	960hPa	<b>Test voltage</b>	DC 5V From Adapter with AC 120V/60Hz
<b>Test Mode</b>	MIMO TX Low		

Freq. (MHz)	Ant. Pol H/V	Peak Reading (dBuV)	AV Reading (dBuV)	Ant. / CL CF (dB)	Actual Fs		Peak Limit (dBuV/m)	AV Limit (dBuV/m)	Margin (dB)	Remark
					Peak (dBuV/m)	AV (dBuV/m)				
1451	H	43.13	---	-10.14	32.99	---	74	54	41.01	Peak
2839	H	42.99	---	-7.59	35.4	---	74	54	38.6	Peak
3607	H	43.4	---	-5.74	37.66	---	74	54	36.34	Peak
4824	H	41.8	---	0.64	42.44	---	74	54	31.56	Peak
N/A										

**Notes:** AV Means AV detector test data, Peak Means Peak detector test data.

Emissions attenuated more than 20 dB below the permissible value are not reported.

<b>EUT</b>	802.11n Wireless Router	<b>Model Name</b>	R0300
<b>Temperature</b>	26°C	<b>Relative Humidity</b>	56%
<b>Pressure</b>	960hPa	<b>Test voltage</b>	DC 5V From Adapter with AC 120V/60Hz
<b>Test Mode</b>	MIMO TX Mid		

Freq. (MHz)	Ant. Pol H/V	Peak Reading (dBuV)	AV Reading (dBuV)	Ant. / CL CF (dB)	Actual Fs		Peak Limit (dBuV/m)	AV Limit (dBuV/m)	Margin (dB)	Remark
					Peak (dBuV/m)	AV (dBuV/m)				
1262	V	43.69	---	-9.84	33.85	---	74	54	40.15	Peak
2013	V	43.11	---	-7.13	35.98	---	74	54	38.02	Peak
3798	V	43.25	---	-5.31	37.94	---	74	54	36.06	Peak
4874	V	42.1	---	0.76	42.86	---	74	54	31.14	Peak

<b>EUT</b>	802.11n Wireless Router	<b>Model Name</b>	R0300
<b>Temperature</b>	26°C	<b>Relative Humidity</b>	56%
<b>Pressure</b>	960hPa	<b>Test voltage</b>	DC 5V From Adapter with AC 120V/60Hz
<b>Test Mode</b>	MIMO TX Mid		

Freq. (MHz)	Ant. Pol H/V	Peak Reading (dBuV)	AV Reading (dBuV)	Ant. / CL CF (dB)	Actual Fs		Peak Limit (dBuV/m)	AV Limit (dBuV/m)	Margin (dB)	Remark
					Peak (dBuV/m)	AV (dBuV/m)				
1511	H	43.32	---	-10.07	33.25	---	74	54	40.75	Peak
2353	H	43.66	---	-8.13	35.53	---	74	54	38.47	Peak
3266	H	42.62	---	-5.52	37.1	---	74	54	36.9	Peak
4874	H	41.87	---	0.76	42.63	---	74	54	31.37	Peak

**Notes:** AV Means AV detector test data, Peak Means Peak detector test data.

Emissions attenuated more than 20 dB below the permissible value are not reported.



<b>EUT</b>	802.11n Wireless Router	<b>Model Name</b>	R0300
<b>Temperature</b>	26°C	<b>Relative Humidity</b>	56%
<b>Pressure</b>	960hPa	<b>Test voltage</b>	DC 5V From Adapter with AC 120V/60Hz
<b>Test Mode</b>	MIMO TX High		

Freq. (MHz)	Ant. Pol H/V	Peak Reading (dBuV)	AV Reading (dBuV)	Ant. / CL CF (dB)	Actual Fs		Peak Limit (dBuV/m)	AV Limit (dBuV/m)	Margin (dB)	Remark
					Peak (dBuV/m)	AV (dBuV/m)				
1477	V	43.75	---	-9.84	33.91	---	74	54	40.09	Peak
2703	V	43.28	---	-7.13	36.15	---	74	54	37.85	Peak
3561	V	42.7	---	-3.84	38.86	---	74	54	35.14	Peak
4924	V	41.05	---	0.87	41.92	---	74	54	32.08	Peak

<b>EUT</b>	802.11n Wireless Router	<b>Model Name</b>	R0300
<b>Temperature</b>	26°C	<b>Relative Humidity</b>	56%
<b>Pressure</b>	960hPa	<b>Test voltage</b>	DC 5V From Adapter with AC 120V/60Hz
<b>Test Mode</b>	MIMO TX High		

Freq. (MHz)	Ant. Pol H/V	Peak Reading (dBuV)	AV Reading (dBuV)	Ant. / CL CF (dB)	Actual Fs		Peak Limit (dBuV/m)	AV Limit (dBuV/m)	Margin (dB)	Remark
					Peak (dBuV/m)	AV (dBuV/m)				
1503	H	43.42	---	-9.27	34.15	---	74	54	39.85	Peak
3588	H	43.6	---	-6.17	37.43	---	74	54	36.57	Peak
4153	H	43.96	---	-4.24	39.72	---	74	54	34.28	Peak
4924	H	42.39	---	0.87	43.26	---	74	54	30.74	Peak

**Notes:** AV Means AV detector test data, Peak Means Peak detector test data.

Emissions attenuated more than 20 dB below the permissible value are not reported.

IEEE 802.11n/HT40 with 2.4G

<b>EUT</b>	802.11n Wireless Router	<b>Model Name</b>	R0300
<b>Temperature</b>	26°C	<b>Relative Humidity</b>	56%
<b>Pressure</b>	960hPa	<b>Test voltage</b>	DC 5V From Adapter with AC 120V/60Hz
<b>Test Mode</b>	MIMO TX Low		

Freq. (MHz)	Ant. Pol H/V	Peak Reading (dBuV)	AV Reading (dBuV)	Ant. / CL CF (dB)	Actual Fs		Peak Limit (dBuV/m)	AV Limit (dBuV/m)	Margin (dB)	Remark
					Peak (dBuV/m)	AV (dBuV/m)				
1551	V	42.14	---	-10.07	32.07	---	74	54	41.93	Peak
2695	V	42.01	---	-6.94	35.07	---	74	54	38.93	Peak
3463	V	41.3	---	-4.95	36.35	---	74	54	37.65	Peak
4844	V	39.89	---	0.64	40.53	---	74	54	33.47	Peak
N/A										

<b>EUT</b>	802.11n Wireless Router	<b>Model Name</b>	R0300
<b>Temperature</b>	26°C	<b>Relative Humidity</b>	56%
<b>Pressure</b>	960hPa	<b>Test voltage</b>	DC 5V From Adapter with AC 120V/60Hz
<b>Test Mode</b>	MIMO TX Low		

Freq. (MHz)	Ant. Pol H/V	Peak Reading (dBuV)	AV Reading (dBuV)	Ant. / CL CF (dB)	Actual Fs		Peak Limit (dBuV/m)	AV Limit (dBuV/m)	Margin (dB)	Remark
					Peak (dBuV/m)	AV (dBuV/m)				
1542	H	41.91	---	-10.14	31.77	---	74	54	42.23	Peak
2358	H	41.77	---	-7.59	34.18	---	74	54	39.82	Peak
3096	H	42.18	---	-5.74	36.44	---	74	54	37.56	Peak
4844	H	40.58	---	0.64	41.22	---	74	54	32.78	Peak
N/A										

**Notes:** AV Means AV detector test data, Peak Means Peak detector test data.

Emissions attenuated more than 20 dB below the permissible value are not reported.

<b>EUT</b>	802.11n Wireless Router	<b>Model Name</b>	R0300
<b>Temperature</b>	26°C	<b>Relative Humidity</b>	56%
<b>Pressure</b>	960hPa	<b>Test voltage</b>	DC 5V From Adapter with AC 120V/60Hz
<b>Test Mode</b>	MIMO TX Mid		

Freq. (MHz)	Ant. Pol H/V	Peak Reading (dBuV)	AV Reading (dBuV)	Ant. / CL CF (dB)	Actual Fs		Peak Limit (dBuV/m)	AV Limit (dBuV/m)	Margin (dB)	Remark
					Peak (dBuV/m)	AV (dBuV/m)				
1628	V	42.47	---	-9.84	32.63	---	74	54	41.37	Peak
2593	V	41.89	---	-7.13	34.76	---	74	54	39.24	Peak
3301	V	42.03	---	-5.31	36.72	---	74	54	37.28	Peak
4874	V	40.88	---	0.76	41.64	---	74	54	32.36	Peak

<b>EUT</b>	802.11n Wireless Router	<b>Model Name</b>	R0300
<b>Temperature</b>	26°C	<b>Relative Humidity</b>	56%
<b>Pressure</b>	960hPa	<b>Test voltage</b>	DC 5V From Adapter with AC 120V/60Hz
<b>Test Mode</b>	MIMO TX Mid		

Freq. (MHz)	Ant. Pol H/V	Peak Reading (dBuV)	AV Reading (dBuV)	Ant. / CL CF (dB)	Actual Fs		Peak Limit (dBuV/m)	AV Limit (dBuV/m)	Margin (dB)	Remark
					Peak (dBuV/m)	AV (dBuV/m)				
1564	H	42.1	---	-10.07	32.03	---	74	54	41.97	Peak
2248	H	42.44	---	-8.13	34.31	---	74	54	39.69	Peak
3159	H	41.4	---	-5.52	35.88	---	74	54	38.12	Peak
4874	H	40.65	---	0.76	41.41	---	74	54	32.59	Peak

**Notes:** AV Means AV detector test data, Peak Means Peak detector test data.

Emissions attenuated more than 20 dB below the permissible value are not reported.

<b>EUT</b>	802.11n Wireless Router	<b>Model Name</b>	R0300
<b>Temperature</b>	26°C	<b>Relative Humidity</b>	56%
<b>Pressure</b>	960hPa	<b>Test voltage</b>	DC 5V From Adapter with AC 120V/60Hz
<b>Test Mode</b>	MIMO TX High		

Freq. (MHz)	Ant. Pol H/V	Peak Reading (dBuV)	AV Reading (dBuV)	Ant. / CL CF (dB)	Actual Fs		Peak Limit (dBuV/m)	AV Limit (dBuV/m)	Margin (dB)	Remark
					Peak (dBuV/m)	AV (dBuV/m)				
1645	V	42.53	---	-9.84	32.69	---	74	54	41.31	Peak
2590	V	42.06	---	-7.13	34.93	---	74	54	39.07	Peak
3851	V	41.48	---	-3.84	37.64	---	74	54	36.36	Peak
4904	V	39.83	---	0.87	40.7	---	74	54	33.3	Peak

<b>EUT</b>	802.11n Wireless Router	<b>Model Name</b>	R0300
<b>Temperature</b>	26°C	<b>Relative Humidity</b>	56%
<b>Pressure</b>	960hPa	<b>Test voltage</b>	DC 5V From Adapter with AC 120V/60Hz
<b>Test Mode</b>	MIMO TX High		

Freq. (MHz)	Ant. Pol H/V	Peak Reading (dBuV)	AV Reading (dBuV)	Ant. / CL CF (dB)	Actual Fs		Peak Limit (dBuV/m)	AV Limit (dBuV/m)	Margin (dB)	Remark
					Peak (dBuV/m)	AV (dBuV/m)				
1792	H	42.2	---	-9.27	32.93	---	74	54	41.07	Peak
2804	H	42.38	---	-6.17	36.21	---	74	54	37.79	Peak
3743	H	42.74	---	-4.24	38.5	---	74	54	35.5	Peak
4904	H	41.17	---	0.87	42.04	---	74	54	31.96	Peak

**Notes:** AV Means AV detector test data, Peak Means Peak detector test data.

Emissions attenuated more than 20 dB below the permissible value are not reported.

## 6 POWER LINE CONDUCTED EMISSION

### 6.1 Conducted Emission Limits(15.207)

Frequency MHz	Limits dB( $\mu$ V)	
	Quasi-peak Level	Average Level
0.15 -0.50	66 -56*	56 - 46*
0.50 -5.00	56	46
5.00 -30.00	60	50

Notes: 1. \*Decreasing linearly with logarithm of frequency.

2. The lower limit shall apply at the transition frequencies.

3. The limit decreases in line with the logarithm of the frequency in the rang of 0.15 to 0.50 MHz.

### 6.2 Test Setup

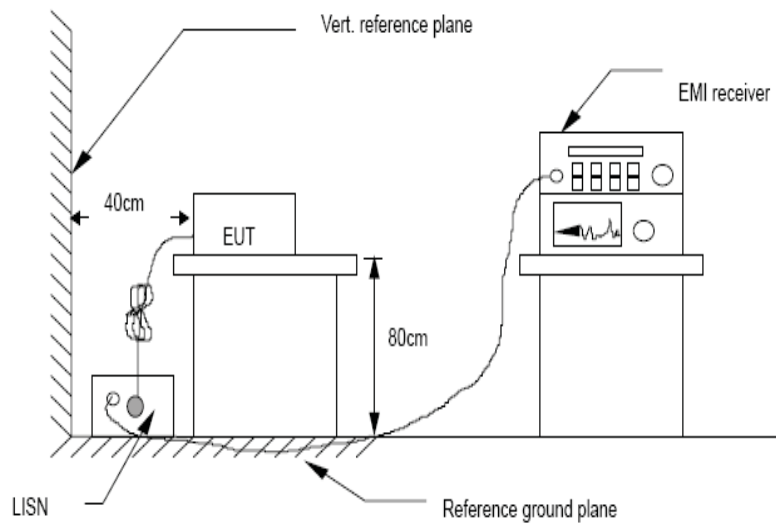

### 6.3 Test Procedure

The EUT is put on the plane 0.8m high above the ground by insulating support and is connected to the power mains through a line impedance stabilization network (L.I.S.N.). This provides a 50ohm coupling impedance for the EUT system. Please refer the block diagram of the test setup and photographs. Both sides of AC lines are checked to find out the maximum conducted emission. In order to find the maximum emission levels, the relative positions of equipment and all of the interface cables shall be changed according to ANSI C63.4:2014 on Conducted Emission Measurement. The bandwidth of test receiver (R & S ESCDLB ECHO 50) is set at 9 kHz.

### 6.4 Test Results

TX MODE

All modes have been tested, and only worse case of 802.11 b mode is reported only.

**PASS**

Detailed information please see the following page.

802.11b ant1:



Shenzhen Alpha Product Testing Co., Ltd.  
 Building B, East Area of Nanchang Second Industrial Zone,  
 Gushu 2nd Road, Bao'an District, Shenzhen 518126, P.R. China  
 Tel: +86-755-29766001 FAX: +86-755-86375565  
 Website: <http://www.a-lab.cn> Email: [service@a-lab.cn](mailto:service@a-lab.cn)

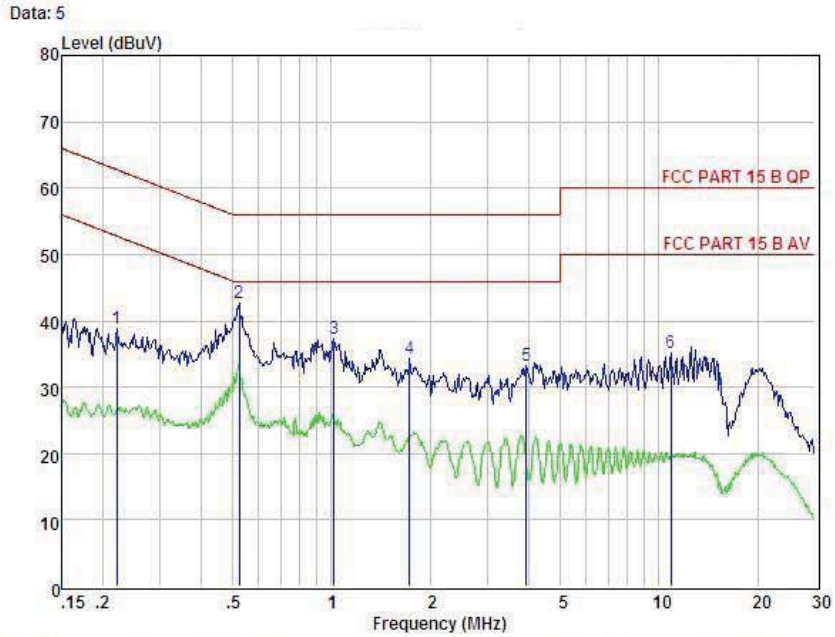

Condition : FCC PART 15 B QP POL: LINE Temp: 23.7 °C Hum: 50 %  
 EUI :  
 Model No :  
 Test Mode :  
 Power :  
 Test Engineer :  
 Remark :

Item	Freq MHz	Read Level dBuV	LISN Factor dB	Preamp Factor dB	Cable Loss dB	Level dBuV	Limit dBuV	Margin dBuV	Remark
1	0.221	29.17	0.03	-9.52	0.10	38.82	62.79	-23.97	Peak
2	0.524	32.99	0.03	-9.58	0.10	42.70	56.00	-13.30	Peak
3	1.021	27.63	0.04	-9.63	0.10	37.40	56.00	-18.60	Peak
4	1.734	24.49	0.05	-9.70	0.10	34.34	56.00	-21.66	Peak
5	3.943	23.08	0.08	-9.87	0.12	33.15	56.00	-22.85	Peak
6	10.905	24.81	0.23	-9.92	0.22	35.18	60.00	-24.82	Peak

Remark: Level = Read Level + LISN Factor - Preamp Factor + Cable Loss



Shenzhen Alpha Product Testing Co., Ltd.  
 Building B, East Area of Nanchang Second Industrial Zone,  
 Gushu 2nd Road, Bao'an District, Shenzhen 518126, P.R. China  
 Tel: +86-755-29766001 FAX: +86-755-86375565  
 Website: <http://www.a-lab.cn> Email: [service@a-lab.cn](mailto:service@a-lab.cn)

Data: 7

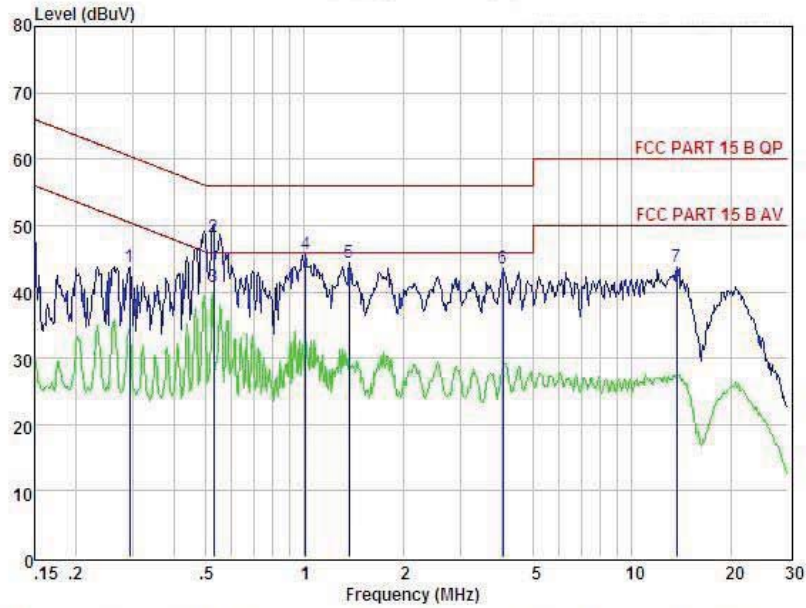

Condition : FCC PART 15 B QP POL: NEUTRAL Temp: 23.7 °C Hum: 50 %  
 EUI :  
 Model No :  
 Test Mode :  
 Power :  
 Test Engineer :  
 Remark :

Item	Freq MHz	Read Level dBuV	LISN Factor dB	Preamp Factor dB	Cable Loss dB	Level dBuV	Limit dBuV	Margin dBuV	Remark
1	0.292	34.15	0.03	-9.56	0.10	43.84	60.46	-16.62	Peak
2	0.529	38.47	0.03	-9.58	0.10	48.18	56.00	-7.82	QP
3	0.529	30.95	0.03	-9.58	0.10	40.66	46.00	-5.34	Average
4	1.010	35.89	0.04	-9.63	0.10	45.66	56.00	-10.34	Peak
5	1.367	34.60	0.05	-9.66	0.10	44.41	56.00	-11.59	Peak
6	4.027	33.40	0.08	-9.88	0.12	43.48	56.00	-12.52	Peak
7	13.695	33.42	0.23	-9.87	0.23	43.75	60.00	-16.25	Peak

Remark: Level = Read Level + LISN Factor - Preamp Factor + Cable Loss



802.11b ant2



Shenzhen Alpha Product Testing Co., Ltd.  
 Building B, East Area of Nanchang Second Industrial Zone,  
 Gushu 2nd Road, Bao'an District, Shenzhen 518126, P.R. China  
 Tel: +86-755-29766001 FAX: +86-755-86375565  
 Website: <http://www.a-lab.cn> Email: [service@a-lab.cn](mailto:service@a-lab.cn)

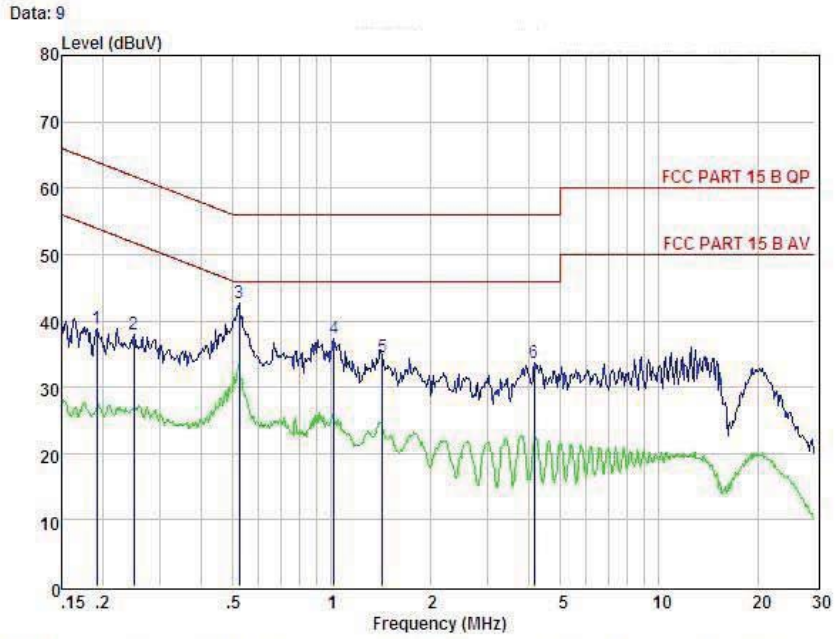

Condition : FCC PART 15 B QP POL: LINE Temp: 23.7 °C Hum: 50 %  
 EUI :  
 Model No :  
 Test Mode :  
 Power :  
 Test Engineer :  
 Remark :

Item	Freq MHz	Read Level dBuV	LISN Factor dB	Preamp Factor dB	Cable Loss dB	Level dBuV	Limit dBuV	Margin dBuV	Remark
1	0.192	29.23	0.03	-9.52	0.10	38.88	63.93	-25.05	Peak
2	0.249	28.39	0.03	-9.52	0.10	38.04	61.78	-23.74	Peak
3	0.524	32.99	0.03	-9.58	0.10	42.70	56.00	-13.30	Peak
4	1.021	27.63	0.04	-9.63	0.10	37.40	56.00	-18.60	Peak
5	1.433	24.67	0.05	-9.66	0.10	34.48	56.00	-21.52	Peak
6	4.158	23.65	0.08	-9.89	0.12	33.74	56.00	-22.26	Peak

Remark: Level = Read Level + LISN Factor - Preamp Factor + Cable Loss



Shenzhen Alpha Product Testing Co., Ltd.  
 Building B, East Area of Nanchang Second Industrial Zone,  
 Gushu 2nd Road, Bao'an District, Shenzhen 518126, P.R. China  
 Tel: +86-755-29766001 FAX: +86-755-86375565  
 Website: <http://www.a-lab.cn> Email: [service@a-lab.cn](mailto:service@a-lab.cn)

Data: 11

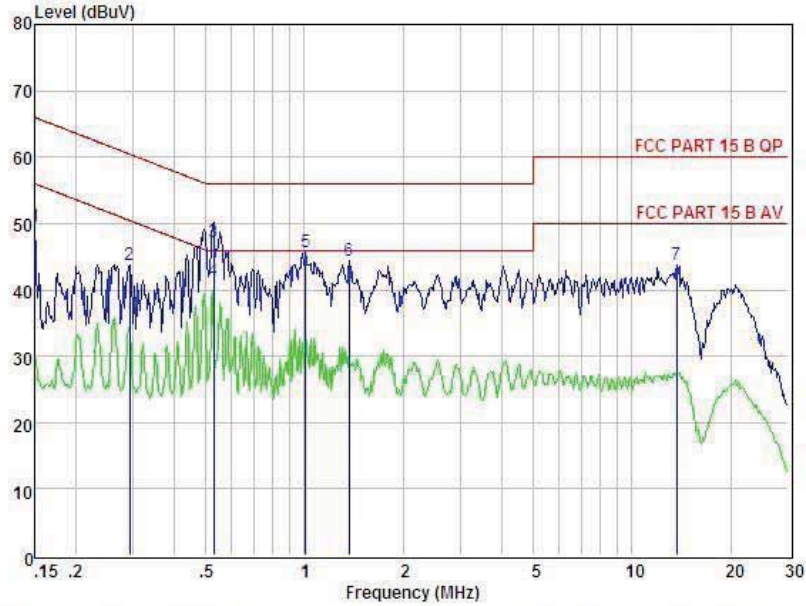

Condition : FCC PART 15 B QP POL: NEUTRAL Temp: 23.7 °C Hum: 50 %  
 EUI :  
 Model No :  
 Test Mode :  
 Power :  
 Test Engineer :  
 Remark :

Item	Freq MHz	Read Level dBuV	LISN Factor dB	Preamp Factor dB	Cable Loss dB	Level dBuV	Limit dBuV	Margin dBuV	Remark
1	0.150	39.90	0.03	-9.49	0.10	49.52	66.00	-16.48	Peak
2	0.292	34.15	0.03	-9.56	0.10	43.84	60.46	-16.62	Peak
3	0.529	37.47	0.03	-9.58	0.10	47.18	56.00	-8.82	QP
4	0.529	31.66	0.03	-9.58	0.10	41.37	46.00	-4.63	Average
5	1.010	35.89	0.04	-9.63	0.10	45.66	56.00	-10.34	Peak
6	1.367	34.60	0.05	-9.66	0.10	44.41	56.00	-11.59	Peak
7	13.695	33.42	0.23	-9.87	0.23	43.75	60.00	-16.25	Peak

Remark: Level = Read Level + LISN Factor - Preamp Factor + Cable Loss

## 7 Conducted Maximum Output Power

### 7.1 Test limit

Please refer section RSS-247 & 15.247.

### 7.2 Test Procedure

Details see the KDB558074 Meas Guidance V03

7.2.1 Place the EUT on the table and set it in transmitting mode.

7.2.2 Measure out each mode and each bands peak output power of EUT.

Note: The cable loss and attenuator loss were offset into measure device as amplitude offset.

Details see the KDB558074 DTS Meas Guidance V03

### 7.3 Test Setup

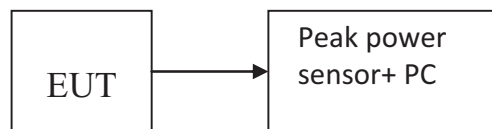

### 7.4 Test Results

**PASS**

Detailed information please see the following page.

EUT: 802.11n Wireless Router	M/N: R0300	
Test date: 2016-05-19	Test site: RF site	Tested by: Reak Yang
Conclusion: PASS		

Mode	Frequency (MHz)	Ant Port	PK Output power(dBm)		Limit (dBm)	Margin (dB)
IEEE 802.11 b	CH1: 2412	0	6.47	6.47	30	23.53
		1	6.21	6.21	30	23.79
	CH6: 2437	0	6.35	6.35	30	23.65
		1	6.28	6.28	30	23.72
	CH11: 2462	0	6.52	6.52	30	23.48
		1	6.46	6.46	30	23.54
IEEE 802.11 g	CH1: 2412	0	3.95	3.95	30	26.05
		1	3.90	3.90	30	26.10
	CH6: 2437	0	3.82	3.82	30	26.18
		1	3.35	3.35	30	26.65
	CH11: 2462	0	3.79	3.79	30	26.21
		1	3.93	3.93	30	26.07
IEEE 802.11 n/HT20 with 2.4G	CH1: 2412	0	3.48	6.36	27.99	/
		1	3.22			
	CH6: 2437	0	3.37	6.32	27.99	/
		1	3.25			
	CH11: 2462	0	3.21	6.26	27.99	/
		1	3.29			
IEEE 802.11 n/HT40 with 2.4G	CH3: 2422	0	1.45	4.34	27.99	/
		1	1.21			
	CH6: 2437	0	1.43	4.23	27.99	/
		1	1.12			
	CH9: 2452	0	1.55	4.38	27.99	/
		1	1.19			
Conclusion: PASS						

## 8 PEAK POWER SPECTRAL DENSITY

### 8.1 Test limit

8.1.1 Please refer section RSS-247 & 15.247.

8.1.2 For direct sequence systems, the peak power spectral density conducted from the intentional radiator to the antenna shall not be greater than 8dBm in any 3kHz band during any time interval of continuous transmission.

8.1.3 The direct sequence operating of the hybrid system, with the frequency hopping operation turned off, shall comply with the power density requirements of paragraph (d) of this section.

### 8.2 Method of measurement

Details see the KDB558074 DTS Meas Guidance V03

8.2.1 Place the EUT on the table and set it in transmitting mode.

8.2.2 Remove the antenna from the EUT and then connect a low loss RF cable from the antenna port to the spectrum analyzer.

8.2.3 Set the spectrum analyzer as RBW = 3kHz, VBW = 10kHz, span=5-30%EBW, detail see the test plot. **Peak detector is used**

8.2.4 Record the max reading.

8.2.5 Repeat the above procedure until the measurements for all frequencies are completed.

### 8.3 Test Setup



## 8.4 Test Results

PASS.

Detailed information please see the following page.

Mode	Frequency (MHz)	Ant Port	PK Output power(dBm)		Limit (dBm)	Result
IEEE 802.11 b	CH1: 2412	0	-20.836	-20.836	8	PASS
		1	-21.065	-21.065	8	PASS
	CH6: 2437	0	-21.096	-21.096	8	PASS
		1	-15.626	-15.626	8	PASS
	CH11: 2462	0	-21.236	-21.236	8	PASS
		1	-18.374	-18.374	8	PASS
IEEE 802.11 g	CH1: 2412	0	-27.729	-27.729	8	PASS
		1	-27.480	-27.480	8	PASS
	CH6: 2437	0	-27.102	-27.102	8	PASS
		1	-25.552	-25.552	8	PASS
	CH11: 2462	0	-27.797	-27.797	8	PASS
		1	-26.085	-26.085	8	PASS
IEEE 802.11 n/HT20 with 2.4G	CH1: 2412	0	-27.231	-24.257	8	PASS
		1	-27.303			
	CH6: 2437	0	-26.941	-24.006	8	PASS
		1	-27.092			
	CH11: 2462	0	-26.971	-23.995	8	PASS
		1	-27.039			
IEEE 802.11 n/HT40 with 2.4G	CH3: 2422	0	-30.649	-27.708	8	PASS
		1	-30.789			
	CH6: 2437	0	-31.230	-27.937	8	PASS
		1	-30.682			
	CH9: 2452	0	-31.089	-27.631	8	PASS
		1	-30.235			
Conclusion: PASS						

Port 0 antenna  
IEEE 802.11b :  
CH Low :



CH Mid:



CH Hig:



IEEE 802.11g :  
CH Low

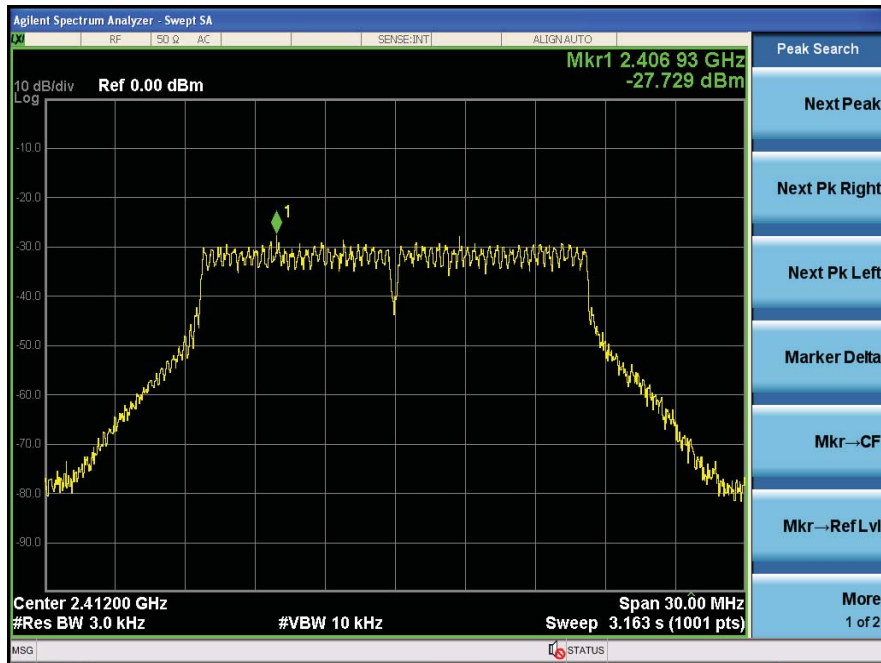



CH Mid:

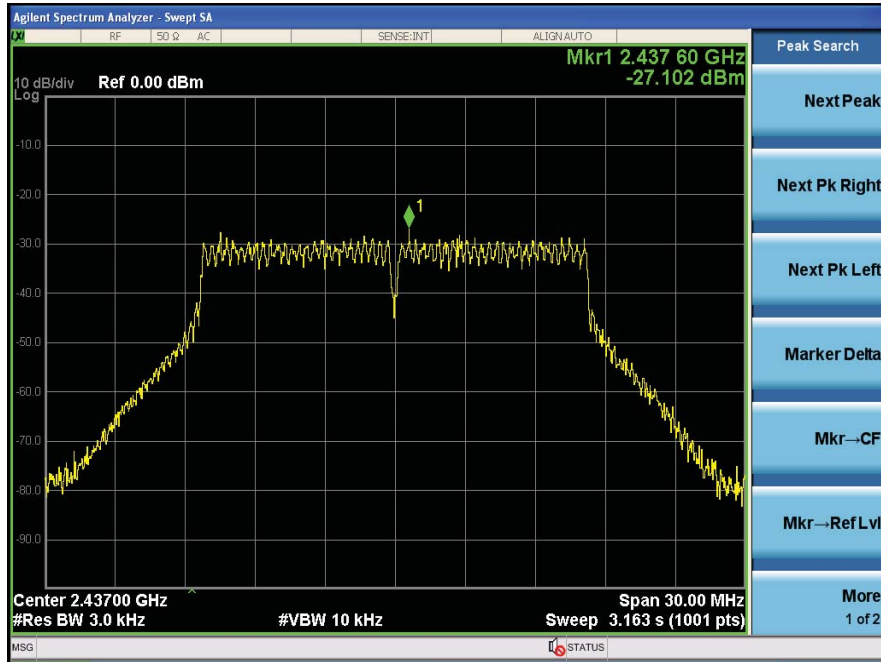

CH Hig:

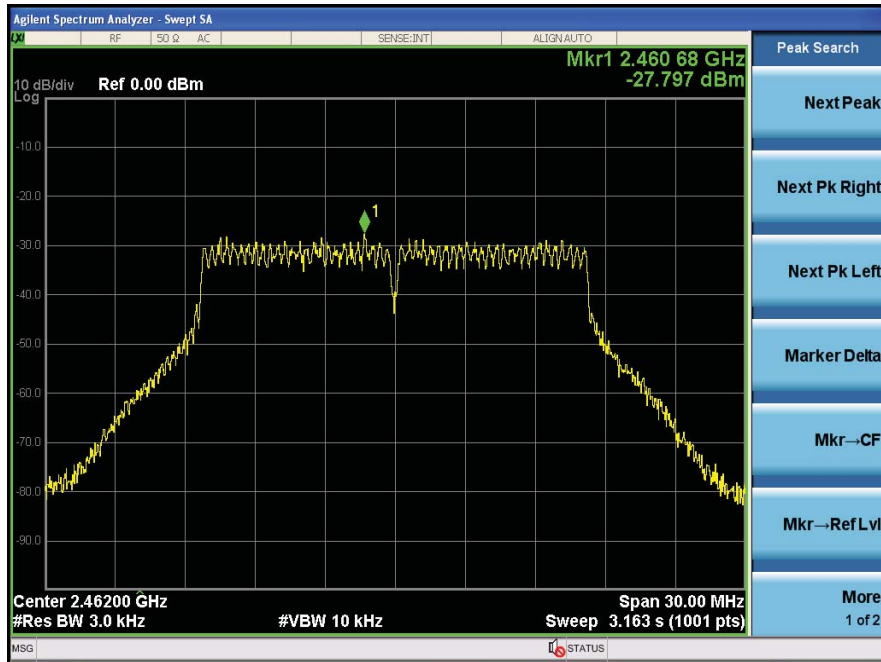

IEEE 802.11n HT20 :

CH Low :

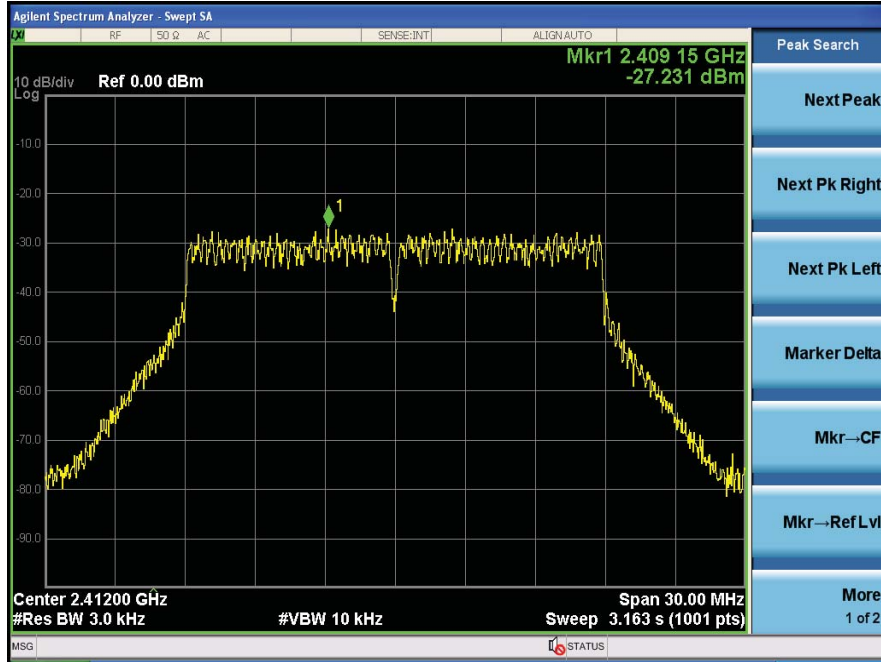

CH Mid:

